

20 TEAM ASSOCIATED 

RC10

1/10 SCALE GAS OFF ROAD TRUCK

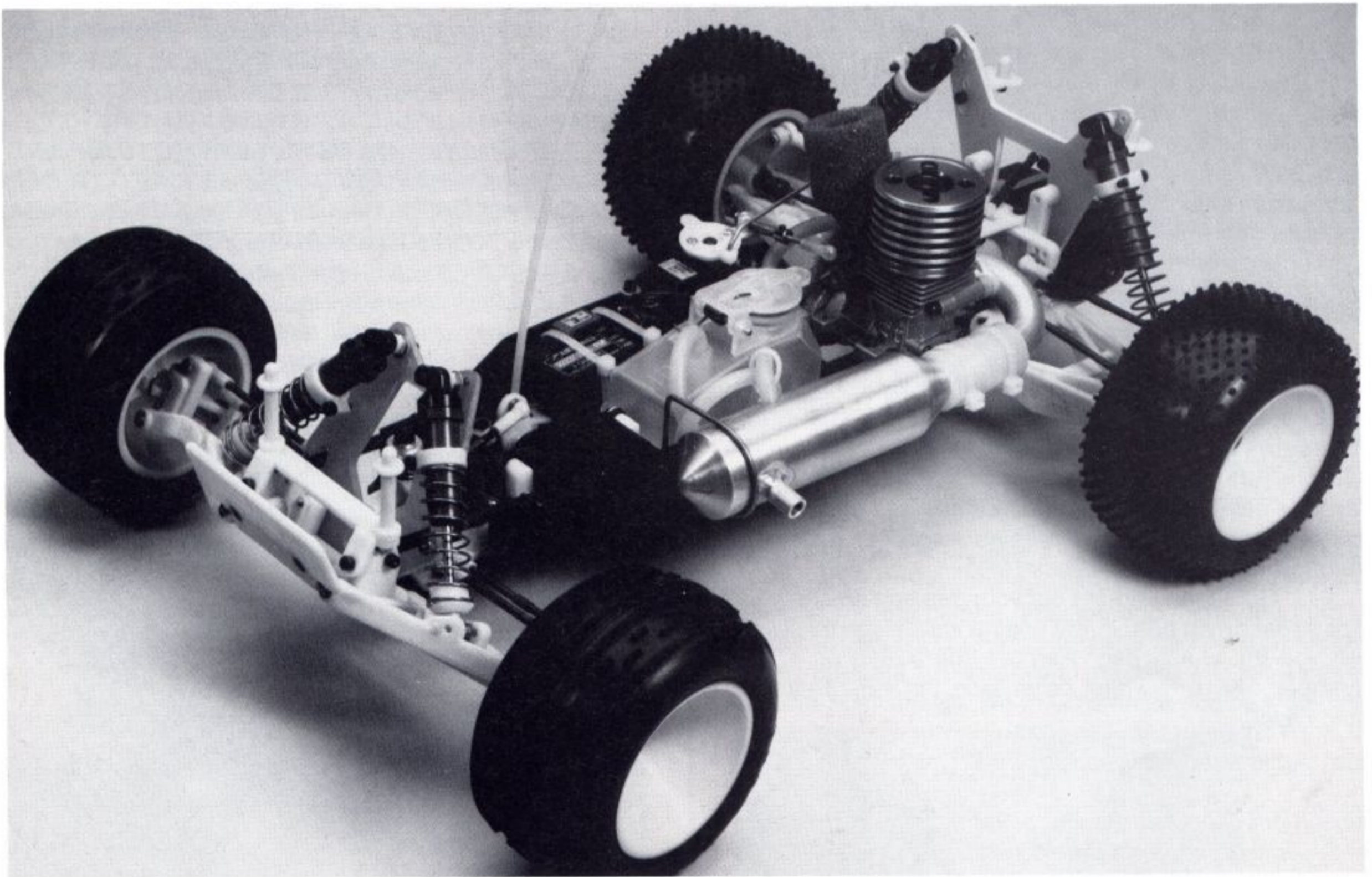

This manual covers the engines similar to the OSMax CZR in size and configuration, such as the Dynamite/TNT and Yokomo .12 size engines, pull start and non pull start.

ENGINE INSTALLATION MANUAL

THIS BOOKLET CONTINUES THE STEPS BEGUN IN THE KIT INSTRUCTION MANUAL. FOLLOW THE OTHER MANUAL INCLUDED IN YOUR KIT BEFORE BEGINNING THESE STEPS.

GAS ENGINE INSTALLATION

We are now ready to start on the installation of your R/C .12ci or .15ci gas engine. There are a lot of engines on the market in this size range that may or may not fit. **WARNING! IT IS THE RESPONSIBILITY OF THE BUYER TO VERIFY THAT THE GAS ENGINE THAT HE OR SHE WISHES TO USE WILL WORK AND/OR FIT IN OUR GAS TRUCK KIT.** The early part of the engine installation shows steps installing both pull start and non-pull start engine parts. Where the parts will be different you will have different parts side by side with the appropriate part numbers indicated. The mounts shown in the photos are for installation of an OS Max, Dynamite-TNT, or Yokomo engine (they all use the same installation parts). The installation sequence will be the same even if you have a different engine.

Warning: This is one of the most critical sections of your gas truck assembly, so make sure you take your time and understand what you are doing before you do it. If you make a mistake on some of the steps you may not be able to correct the problem without replacing some very expensive parts.

□ **Figs. 243 & 244** We will now need to get out the Dremel tool, the fiber reinforced cutoff wheel and especially your safety glasses. **Warning:** We recommend using only the fiber reinforced wheels, not the cutoff stones, for your own safety. The cutoff stones can shatter and cause injury. Fig. 243 shows the correct fiber reinforced cutoff wheel next to our Dremel tool.

Go ahead and get out your gas engine and your plastic sandwich bag. In the engine installation pack you will find the clutch bag. Remove the #7610 or #7612 flywheel, #7618 flywheel collet, and the #7620 special cutoff nut.

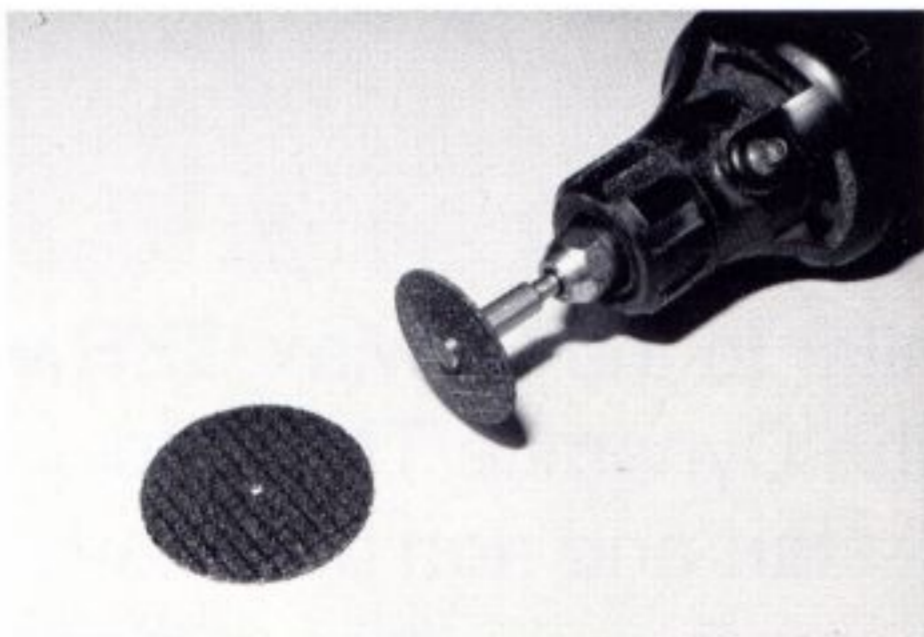

Fig. 243

Super Duty Fiberglass Cut-off Wheel, Moto-tool© part #426.

Dremel Moto-Tool©

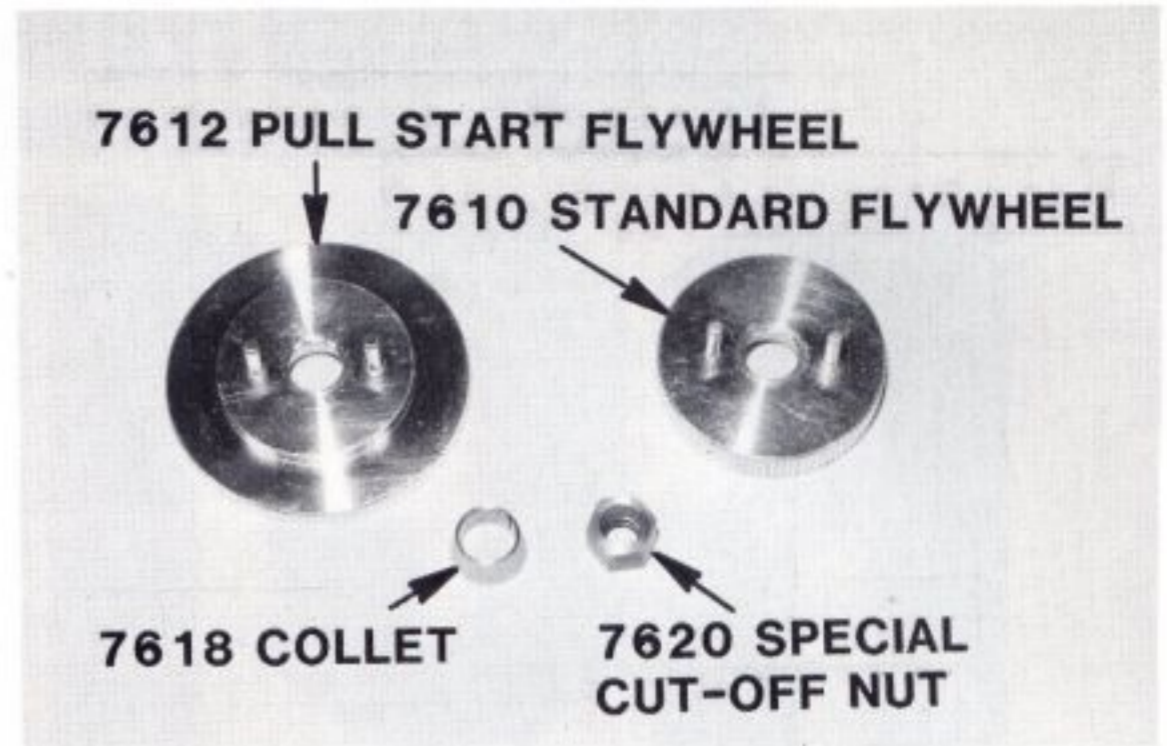
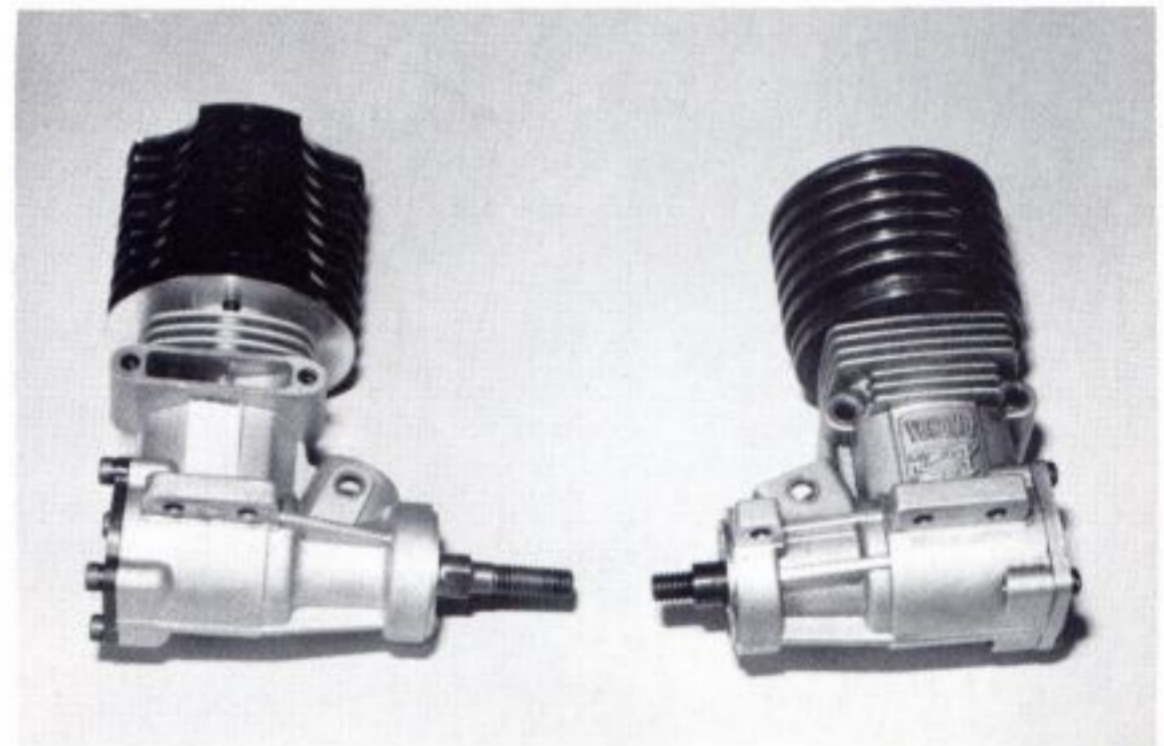

Fig. 244

□ **Figs. 245 & 246** Fig. 245 shows an old style O.S. Max standard length crank on the left and a Yokomo crank already cut on the right. **NOTE:** The Dynamite engine comes with the crankshaft already cut. If you have a standard length crankshaft, the following steps show you how to modify it.

WARNING! OS MAX CZR MOTORS AND CRANKSHAFTS MANUFACTURED BEFORE OCTOBER 1993 WILL REQUIRE THE USE OF A #7604 SPECIAL CLUTCH NUT NOT STANDARD IN THE KIT. The drawings in fig. 246 show the difference in the old style crankshaft compared with the newer crankshaft (made after Oct. 1993). The old style crank will require a different clutch nut, Associated part number #7604. **NOTE:** Many of these engines come with a prop spacer installed. It needs to be removed before you start cutting.



↑ O.S. or Dynamite

Yokomo ↑

Fig. 245

more threads

fewer threads

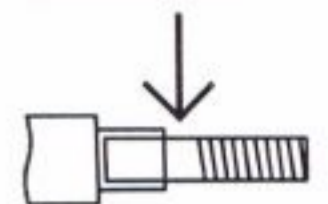
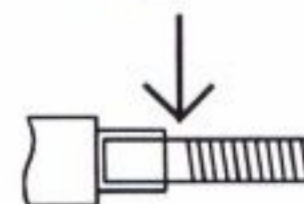

new style
(after Oct. 1993)

old style
(needs clutch nut
#7604, not in kit)

Fig. 246

□ **Figs. 247, 248 & 249** To set up the crankshaft for modification, first install the collet on the crankshaft, followed by the flywheel. The flywheel will fit over the collet (they are a tapered wedge fit). Now we need to install the special cutoff nut. If you look closely at the nut you will see only one side of the nut is threaded. Install the nut so the threaded end is away from the flywheel. Hold the flywheel in one hand and using your 5/16" nut driver or glow plug wrench, hand tighten the special nut onto the crankshaft.

Place the engine inside the plastic sandwich bag and close the bag around the engine. Push the end of the crankshaft through the plastic bag until the end of the shaft and the special cutoff nut are exposed through the bag.

Warning: Take your time; the hole must be tight around these parts so we can prevent metal shavings from getting inside the engine. Cut the crankshaft flush with the end of the special cutoff nut using the Dremel tool. THESE STEPS ARE ALSO SHOWN IN THE VIDEO SO YOU CAN SEE HOW IT WAS DONE BEFORE YOU CUT YOUR OWN CRANKSHAFT. **WARNING!! NEVER WORK WITH A POWER TOOL WITHOUT WEARING SAFETY GLASSES OR GOGGLES! MAKE SURE ALL PARTS OF YOUR BODY AND ANY CLOTHING ARE AWAY FROM THE DREMEL TOOL AND THE CUTTING AREA TO PREVENT INJURY.** Take your time cutting the crankshaft. Always make sure a have a firm hold on the parts and the Dremel tool. You need to make sure that you do not slip and damage the flywheel clutch pins while cutting.

After you have cut the crankshaft, clean off any metal shavings from the parts, then remove the engine from the plastic bag. Unthread the special cutoff nut, remove the flywheel and the collet. Remove the #7603 clutch nut from the clutch parts bag. See if the clutch nut will thread onto the crankshaft easily. If not, then you may want to file or grind a little from the top of the first thread on the crankshaft. Remember to put the motor back in the plastic bag and be very careful so you do not damage the actual threads.

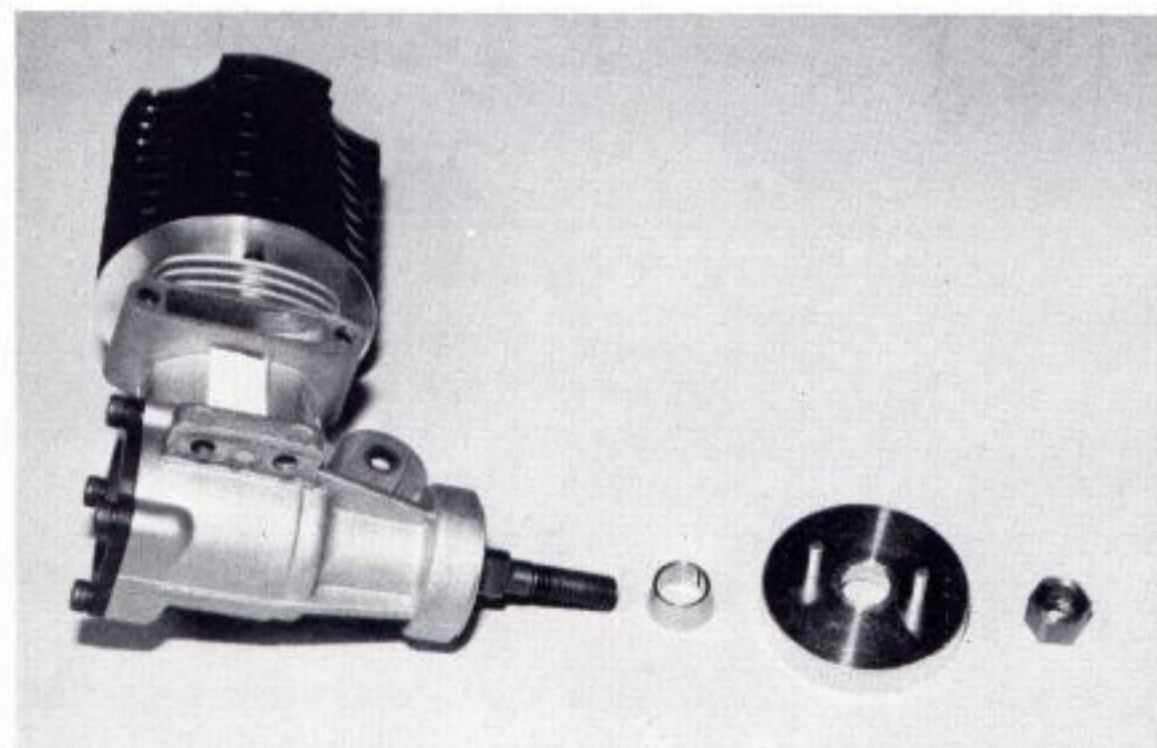

Fig. 247

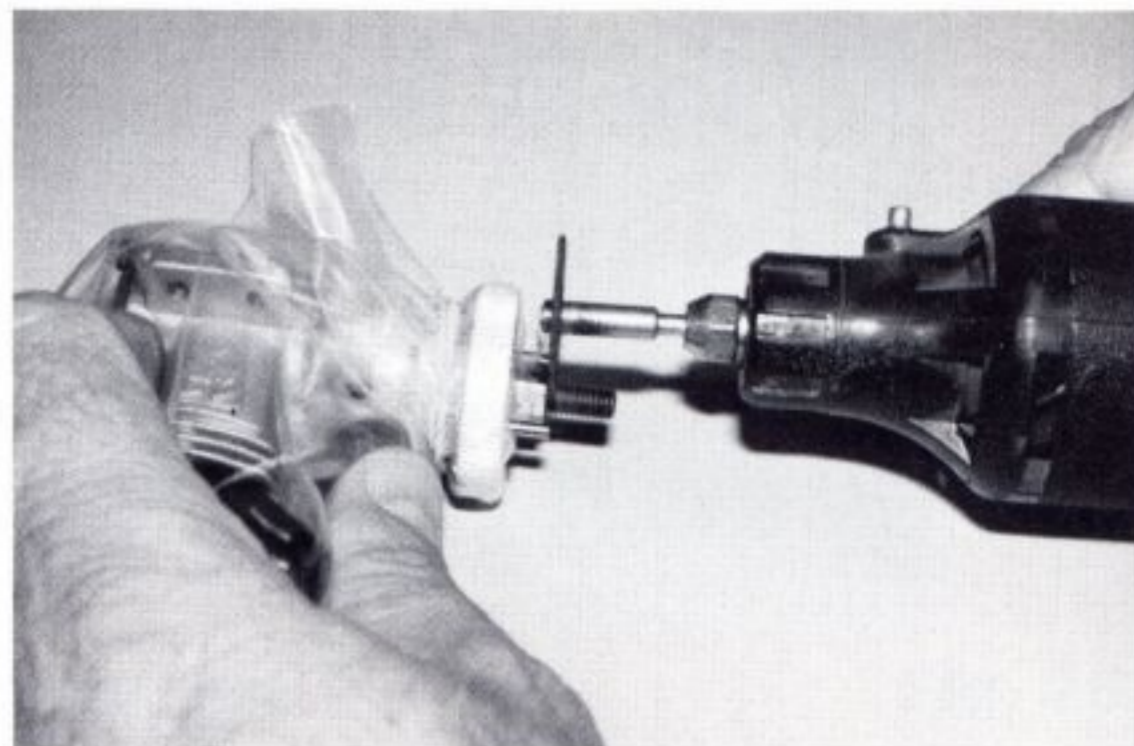

Fig. 248

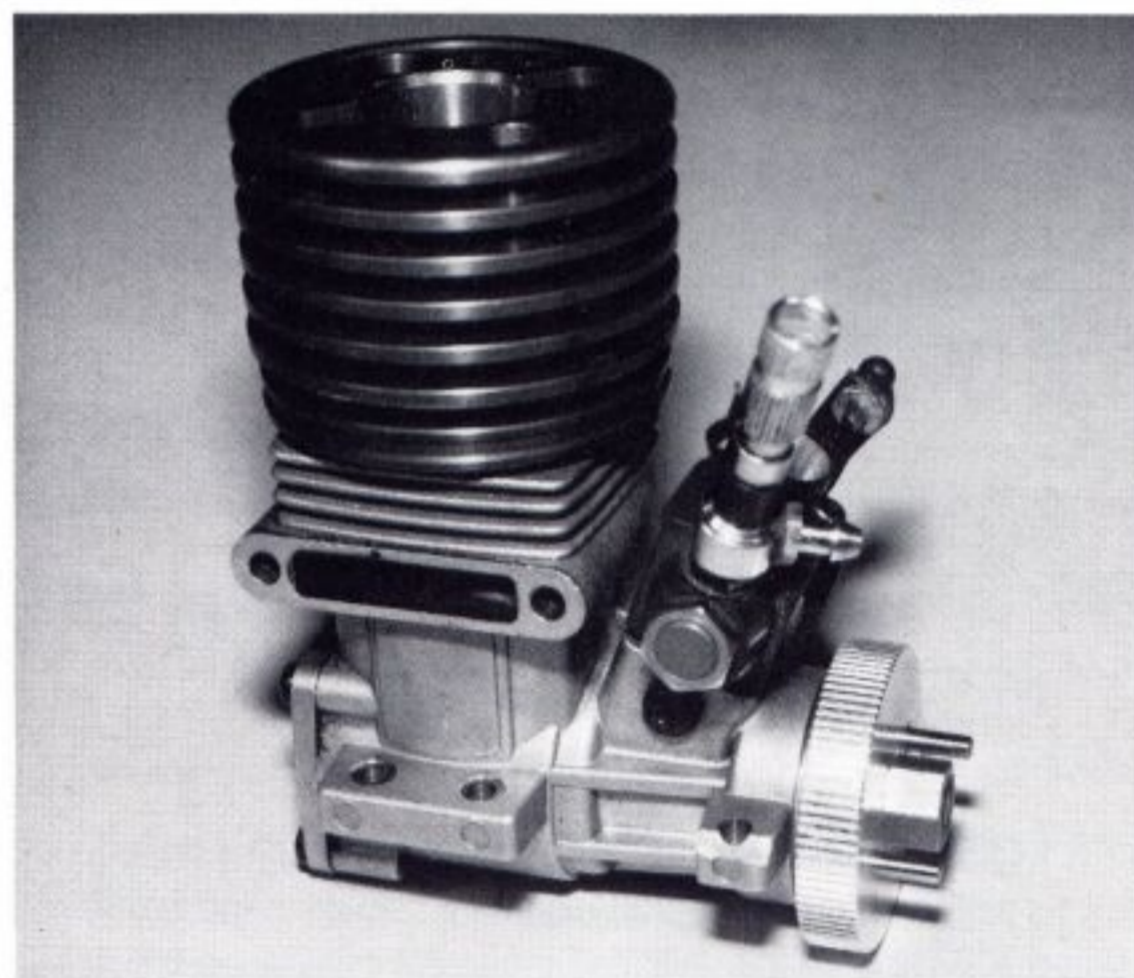

Fig. 249

□ **Figs. 250 & 251** We now need to remove the carburetor from the engine so we can turn the needle valve assembly in the correct direction and install the throttle pivot arm ball end. On the OS Max and the Yokomo engines the carburetors are fastened to the case with two screws; remove both screws. On the Dynamite engine there is a clamp bolt and nut behind the carburetor (on the exhaust side), loosen this nut. Now you can slide the carburetor out of the engine case.

We are now going to have to loosen the needle valve locknut at the base of the needle valve assembly (see arrow, fig. 250). The locknut at the base of the needle valve on the OS Max and Yokomo carburetors is very difficult to get to. Your Associated shock/turnbuckle wrench will work for this nut; it's thin enough to fit under the needle valve. Now we will need to turn the valve assembly until the fuel line fitting is facing the direction shown in fig. 251. Fig. 250 shows the carburetor as it would be mounted on the engine when installed. You will be threading the valve assembly in or out to get the fitting to face the correct way. After you have the fitting pointing correctly, go ahead and retighten the valve assembly locking nut.

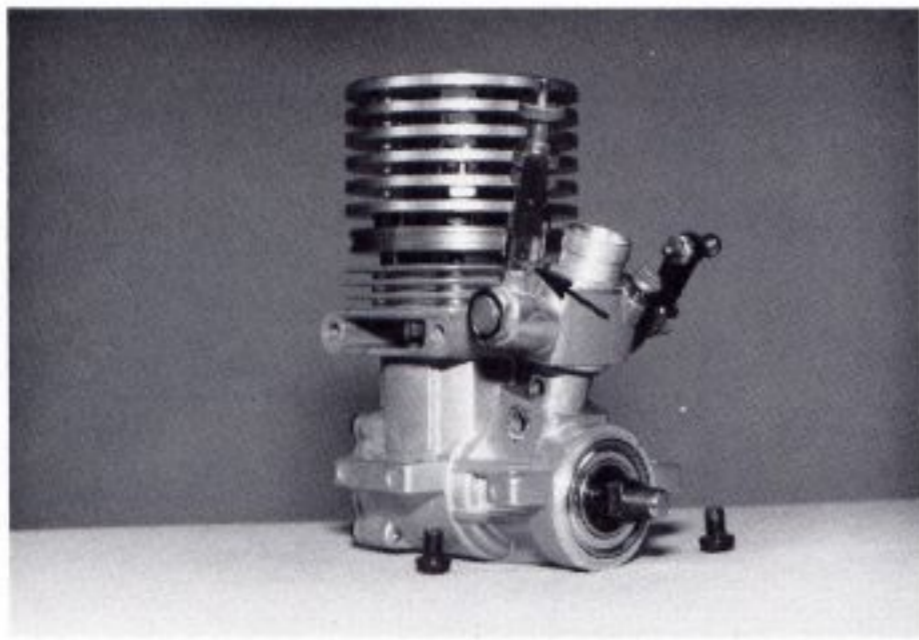

Fig. 250

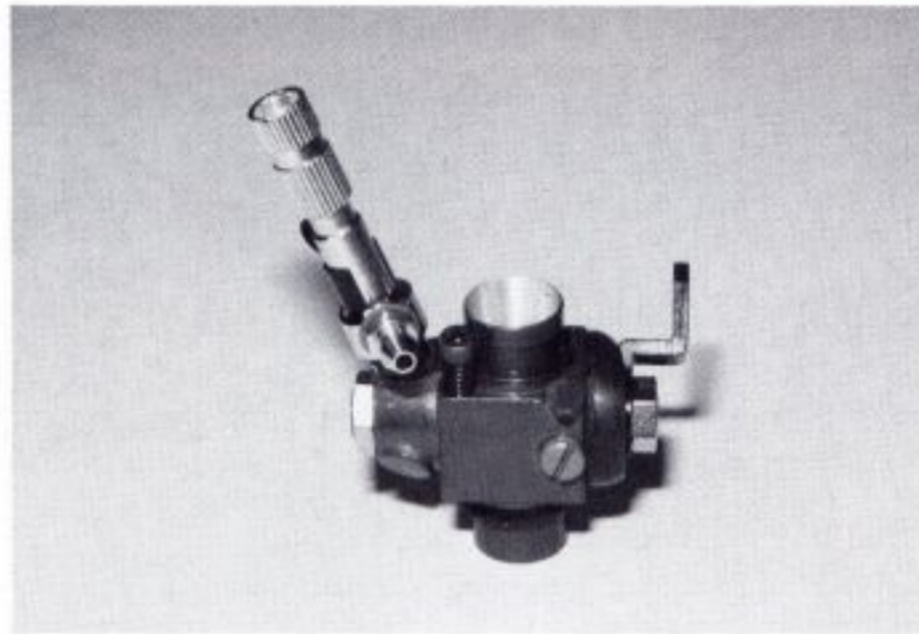

Fig. 251

□ **Figs. 252 & 253** In bag #7-15 of your truck kit you will find one 2-56 thread steel ball end and one 2-56 plain nut. The hole in the throttle pivot arm may be too small for the 2-56 threaded ball end so we will need to drill it out. Use a #43 (.0890") drill bit, or you can use a 3/32" drill bit if you are extremely careful. **Warning: the throttle pivot arms are very small and can be easily damaged. Use extreme care when drilling the hole.**

Now mount the ball end on the pivot arm with the ball facing away from the carburetor. Thread the 2-56 nut onto the other end and tighten. We recommend using Loctite on the threads to keep the nut from coming loose due to engine vibrations. Reinstall the carburetor to the engine and tighten the clamp nut or the mounting screws. We want the throttle pivot arm to be parallel with the crankshaft on the Dynamite engine; the other engines have fixed carb locations. See fig. 256.

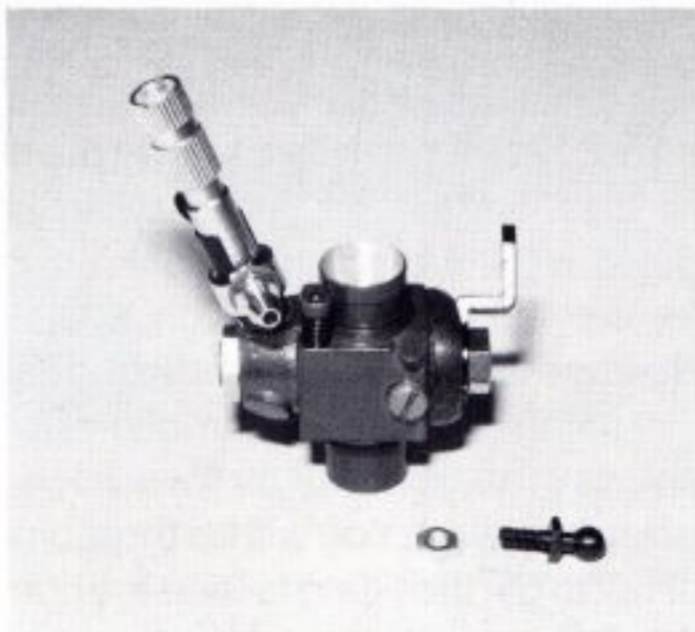

Fig. 252

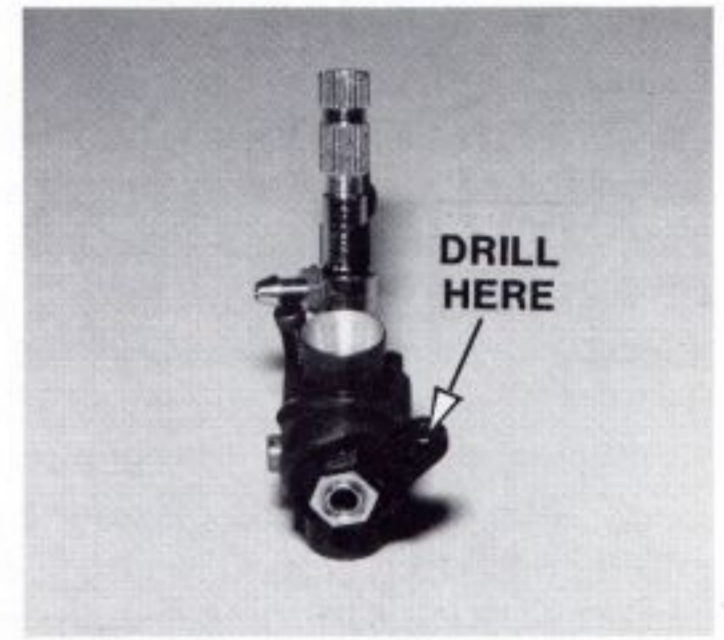

Fig. 253

□ **Figs. 254 & 255** We are now ready to start final assembly of the flywheel and clutch parts. In the clutch bag you will find the #7618 flywheel collet spacer. Install it on the crankshaft (if you have a Yokomo engine). Now you can reinstall the #7618 collet and the #7610 or #7612 flywheel. Thread on the #7603 clutch nut. Tighten the clutch nut securely to lock the flywheel to the collet. Take a pair of slip joint pliers and grab the outer edge of the flywheel. Now use your 5/16" nutdriver to tighten the clutch nut against the flywheel. Get it as tight as you can using these tools.

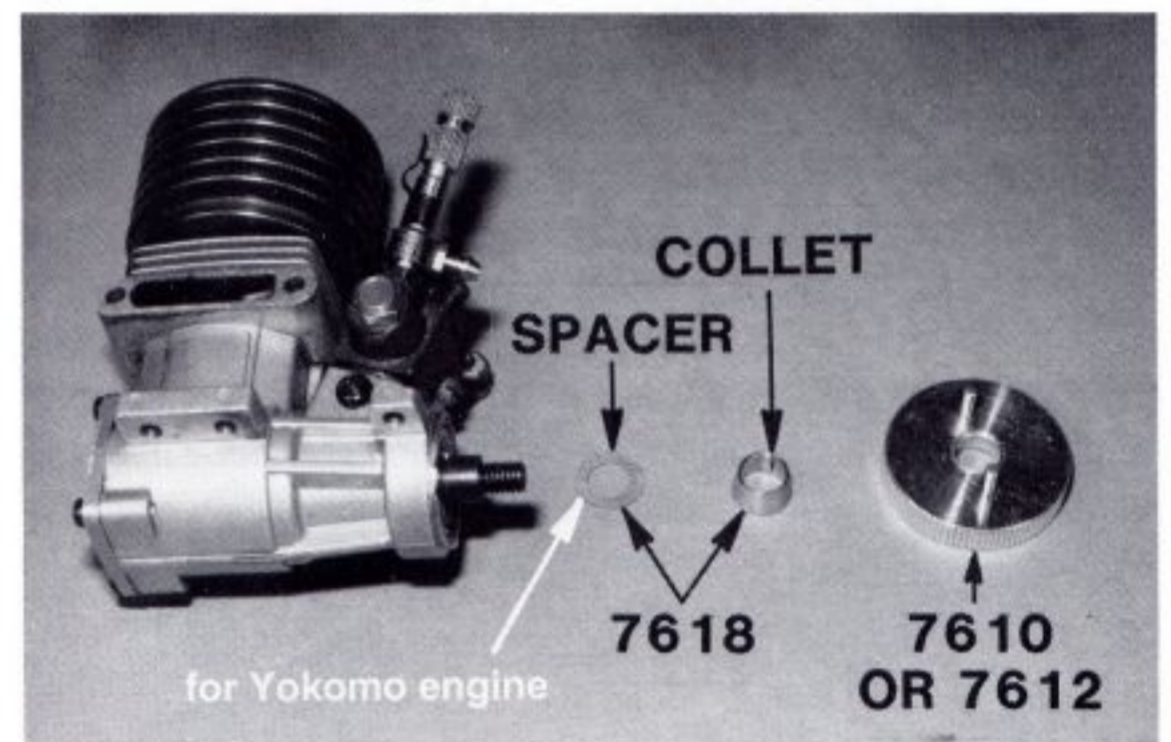

Fig. 254

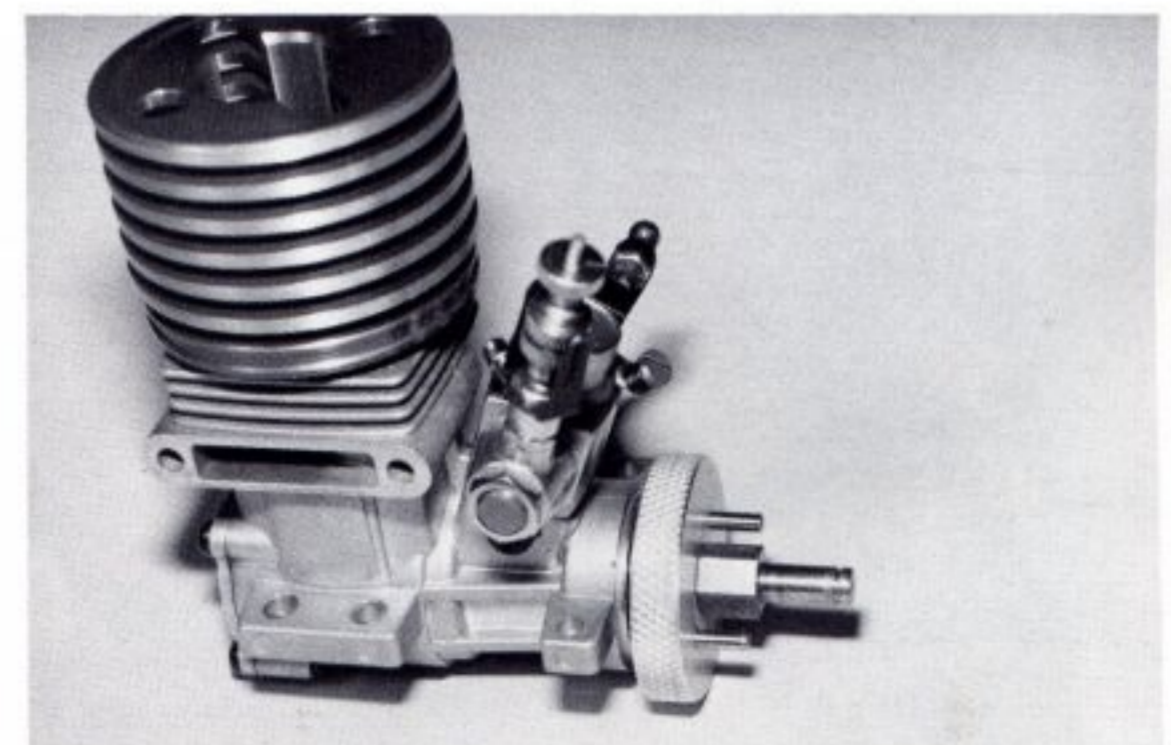

Fig. 255

□ **Figs. 256, 257 & 258** Now we need to get out the two #7601 clutch shoes and the #7602 clutch shoe spring. Before we install the clutch shoes we need to deburr the four small holes in the clutch shoes with an X-acto® knife. Do both sides. The clutch shoes install as shown in fig. 256. Before we install the clutch spring, check and make sure that both of the spring legs are straight and not bent. If they are bent, carefully straighten them with your needlenose pliers. Trying to install springs, with bent legs, into the clutch shoes can cause the spring to break. There are four holes in the clutch shoes so that you can tune the clutch to match the track conditions and your driving style. To start with, use the third hole from the flywheel pivot pins. We will discuss more detailed clutch tuning a little later in the instruction manual.

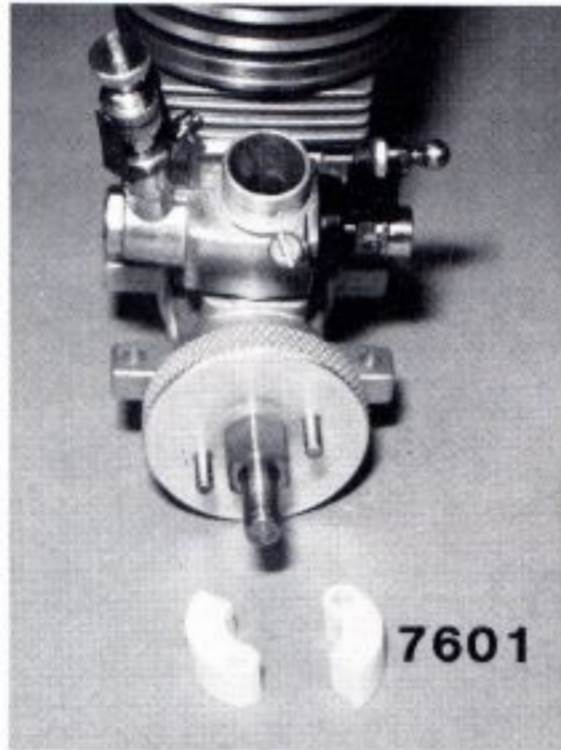

Fig. 256

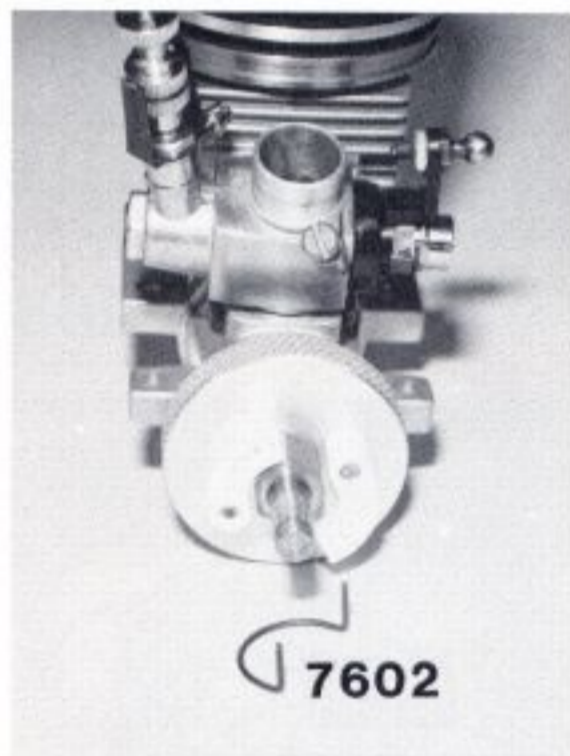

Fig. 257

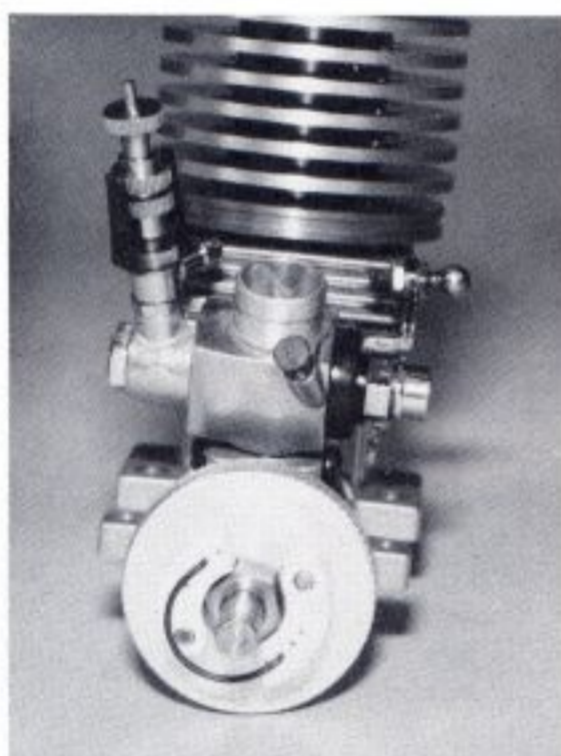

Fig. 258

□ **Figs. 259 & 260** Take out the #7606 16 tooth 32 pitch clutch bell and the two #6902 3/16" x 5/16" flanged ball bearings or the two #6863 3/16" x 5/16" flanged bushings from the clutch bag. Install one bearing or bushing into each side of the pinion gear hole. The bearings or bushings should install with only finger pressure; if not, sand the inside of the edge of the hole to remove any possible burrs until you can push them in. Now slide the clutch bell assembly onto the clutch nut as shown. In the clutch bag you will find the #2661 clutch nut E-clip. This will slide into the groove in the end of the clutch nut to hold the clutch assembly in place. We will now set the engine aside for a few steps. **Note:** the following figures will show the installation of a Yokomo non-pull start engine for photo clarity; a pull start engine will install the same way.



Fig. 259

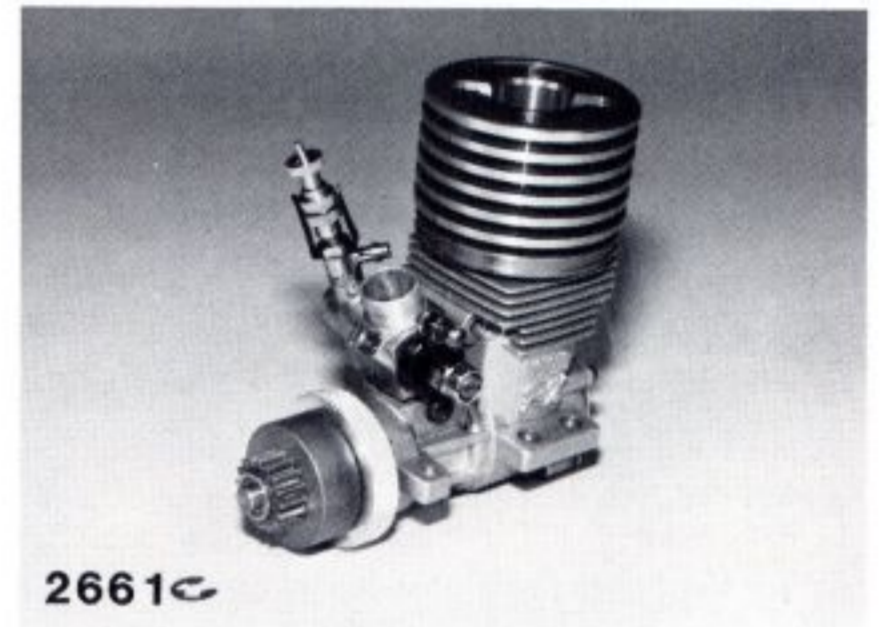
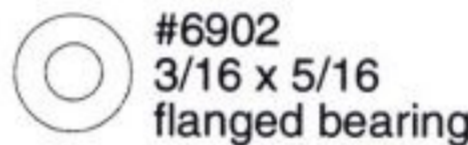

Fig. 260



#2661
E-clip

2661



#6902
3/16 x 5/16
flanged bearing

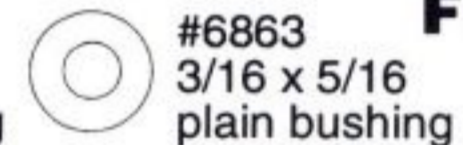

#6863
3/16 x 5/16
plain bushing

□ **Figs. 261, 262 & 263** Open the engine mount bag, in the engine installation pack, and remove the #7627 or #7629 engine mount adapters (your mounts should be black), two #7633 4-40 x 5/8" BHSScrews, two #6925 4-40 x 1/2" SHCScrews, and two #3216 #4 steel washers (gold colored). We will start with the #7627 rear engine mount adapter and the two #7633 BHSScrews as shown in fig. 261. The two button head screws will install from the bottom of the chassis. They will go through the slots in the rear engine mount and then thread into the rear engine mount adapter as shown in fig. 263. We want to be able to slide the adapters forward or backwards, so only lightly secure the mounting screws.

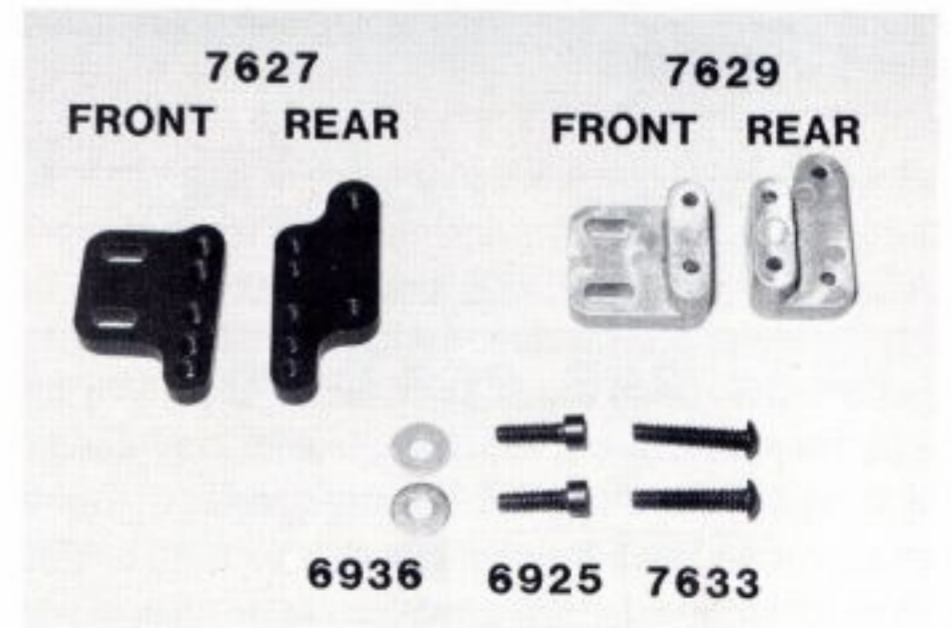



Fig. 261

 #3216
#4-40 steel
flat washer

 #6925
4-40 x 1/2

 #7633
4-40 x 5/8



7627 REAR

Fig. 262

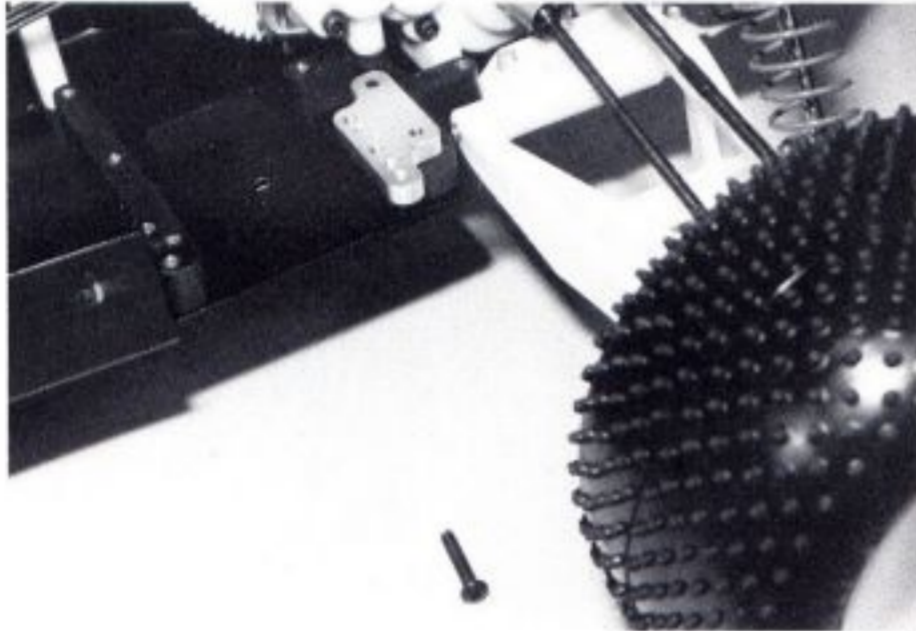
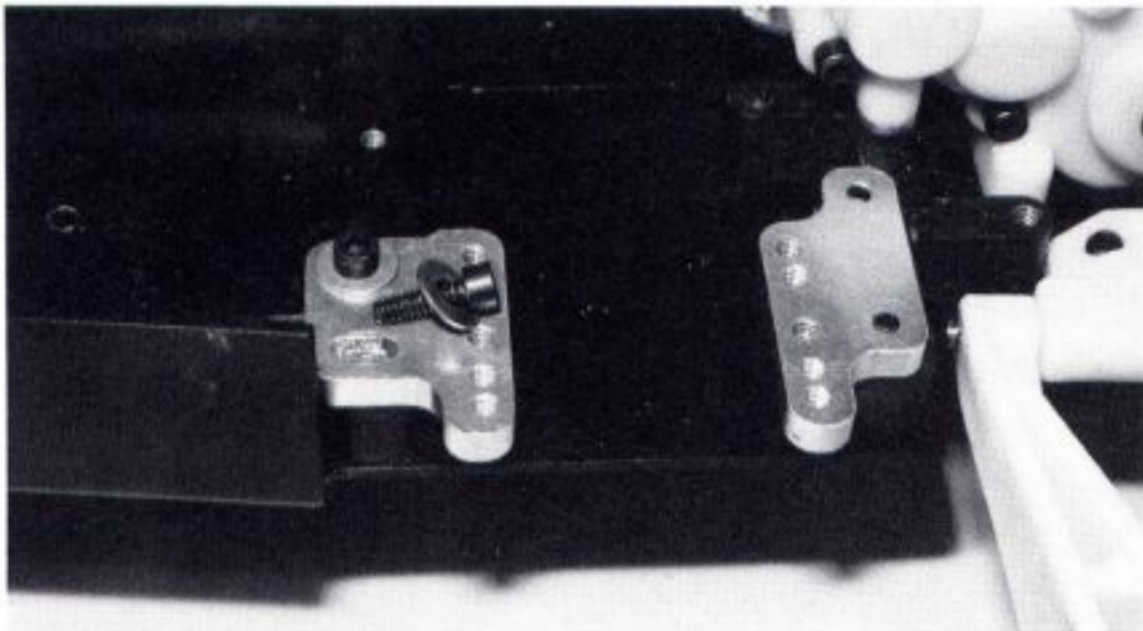



Fig. 263

Fig. 264 Now we will install the #7627 front engine mount adapter using the two #6925 4-40 x 1/2" SHCScrews and the two #3216 #4 gold colored #steel washers. Install the front adapter with the two screws and washers as shown in fig. 264. Again, we need to be able to slide the adapters, so only lightly secure the screws.



 #3216
#4-40 steel
flat washer

 #6925
4-40 x 1/2

Fig. 264

Figs. 265, 266 & 267 We are now ready to take your engine with clutch and flywheel assembly and secure it to the engine mount adapters. In the engine mount bag you will find four #6924 4-40 x 3/8" SHCScrews. The non-pull start adapters have several sets of holes on them, but only one set will line up with your motor and let you mesh the gears correctly. The pull start adapters for the OS Max,

Dynamite, and Yokomo engines has only one set of holes for mounting the engine. Center your engine on the adapters and line up your clutch bell gear with the spur gear. Your engine mounts should match up with one of the sets of holes in the adapters. Now fasten the motor to the adapters with the four #6924 SHCScrews. You may have to slide the adapters to be able to install the four screws. Once they're installed, tighten them.

We are now ready to set the spur gear-to-pinion gear spacing. Make sure you can still slide your engine and adapters, then mesh the clutch bell pinion with the spur gear. The correct gear spacing is when the pinion is as close to the spur gear as possible, fig. 267, but if you hold the pinion gear, you should still be able to rock the spur gear back and forth slightly with light finger pressure. Spin the gears and check the mesh in several different locations just in case the spur gear is slightly out of round or worn.

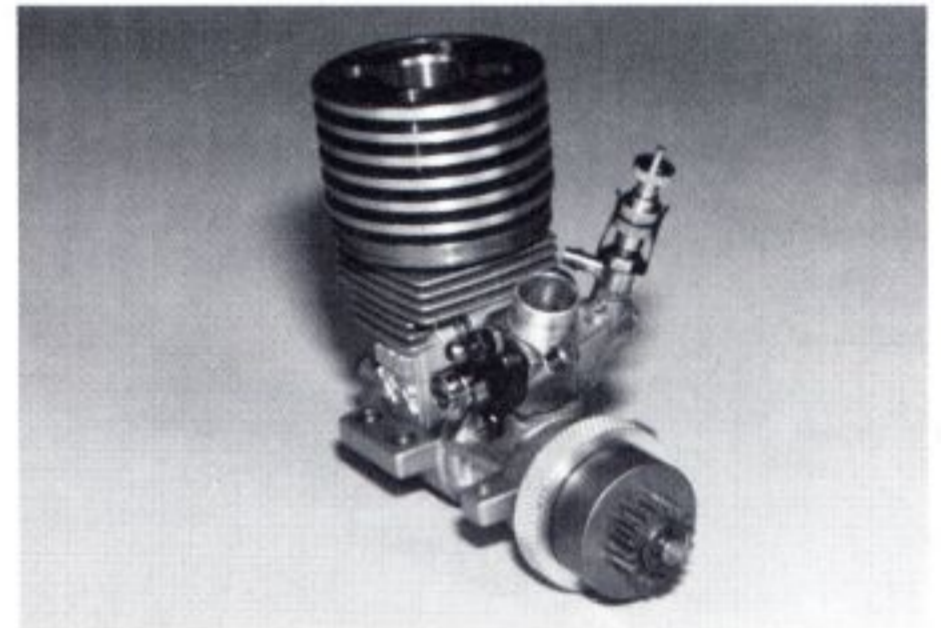

 #6924
4-40 x 3/8

Fig. 265

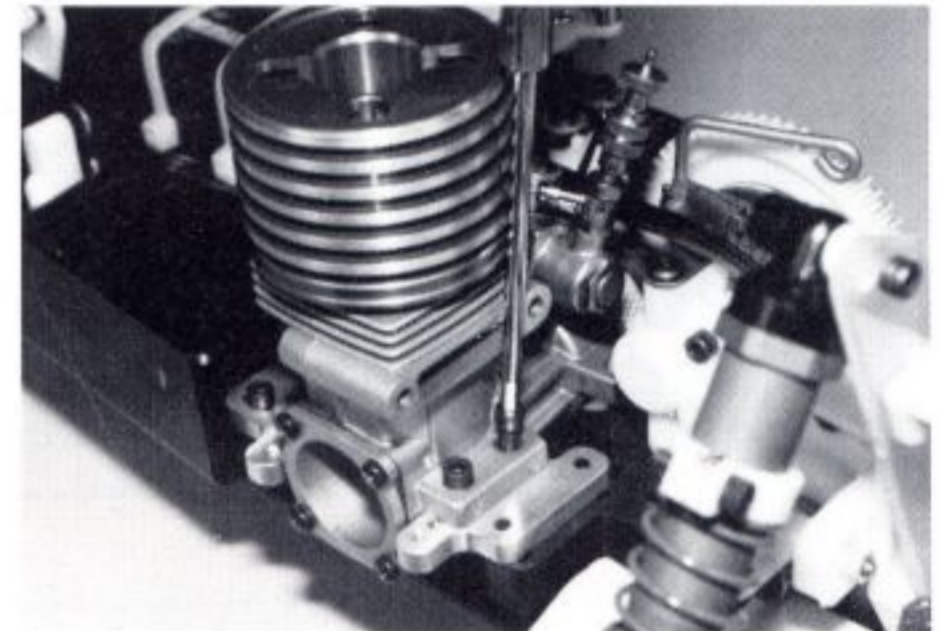

Fig. 266

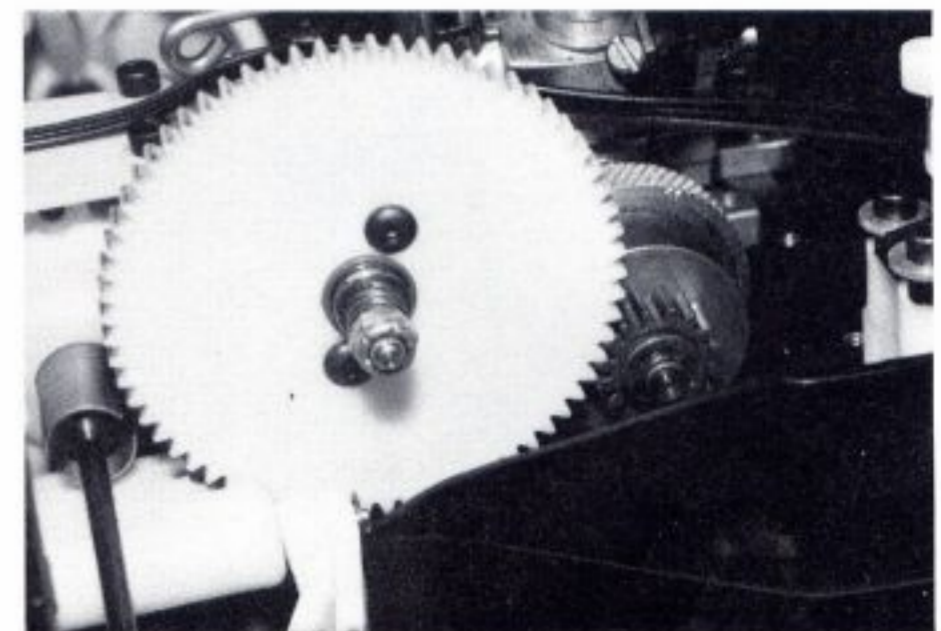

Fig. 267

☐ **Figs. 268, 269 & 270** Go back to the truck kit and remove the #7720 fuel tank (the #7723 90° fuel tank fitting will already be installed). From the fuel tank bag remove the three #5407 red O-rings and the three #7673 4-40 x 5/16" FHSScrews. Mount the fuel tank the same way we did earlier in the truck instructions in fig. 220. Tighten the screws down just enough to slightly compress the O-rings so the fuel tank cannot move around.

In the Engine Accessory Pack you will find the #7724 fuel line tubing. Slide one end of the fuel tubing onto the fuel outlet fitting, which is facing to the right (fig. 268). Bring the other end of the tubing as in fig. 270. When you have the correct length as shown in fig. 270, without kinks in the tubing or chafing against any truck parts, go ahead and mark the fuel tubing and the cut it at that location. Now connect the fuel tubing to as shown in fig. 270. Again, make sure the fuel line clears the spur gear or any other parts on the truck that could cause chafing against the fuel tubing.



Fig. 268

⊙ #5407
red O-ring

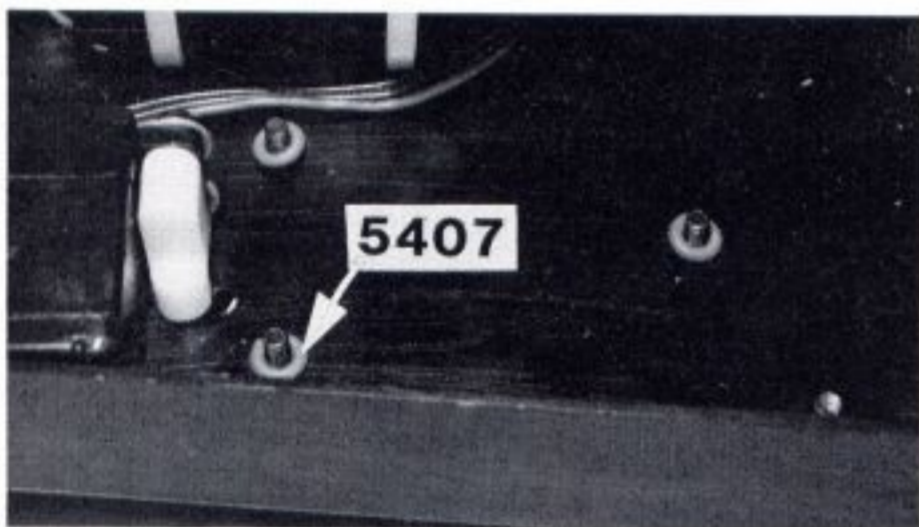

Fig. 269

⌘ #7673
4-40 x 5/16

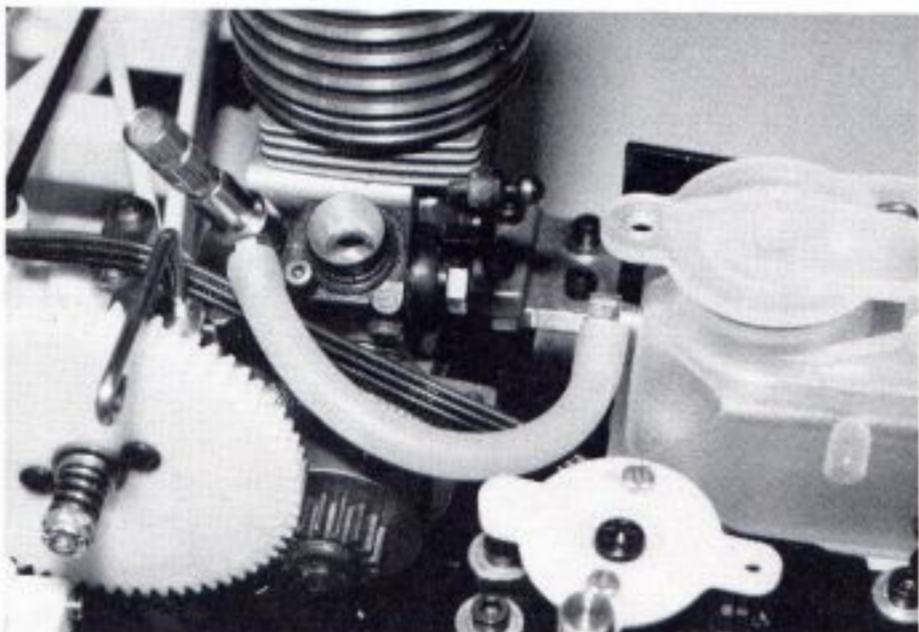

Fig. 270

☐ **Figs. 271, 272 & 273** Now go to the throttle/brake linkage bag #7-15 (in the truck kit) and remove the throttle linkage parts shown in fig. 271. These parts consist of the 2-56 threaded rod, the plastic ball end cap, two .075 collars with 4-40 set screws and the #6372 spring (all of these parts are in the replacement #7560 throttle/brake linkage kit). We are going to assemble the parts in the order shown in fig. 272. Thread the plastic ball end cap onto the throttle rod as shown and set the collar spacing as shown. (The collar set screws use your .050 Allen wrench.) Slide the throttle rod through the #7557 throttle pivot and fasten the second collar onto the rod as shown in fig. 273. Now snap the plastic ball end cap onto the throttle pivot arm ball end, fig. 273. We will make adjustments to the throttle linkage and rod length later in the instructions.

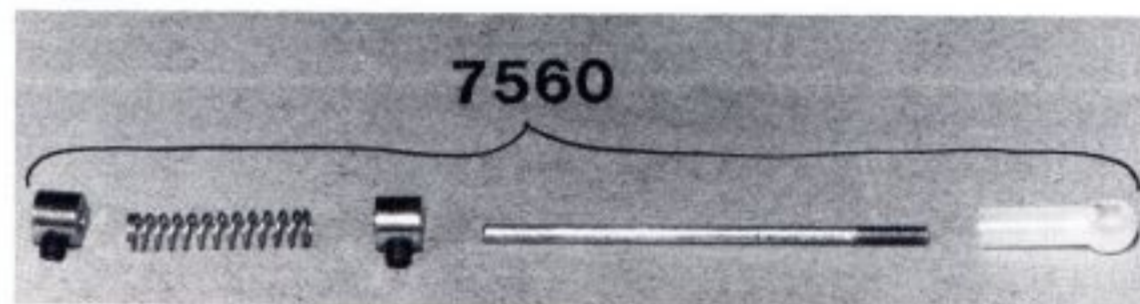

Fig. 271



Fig. 272

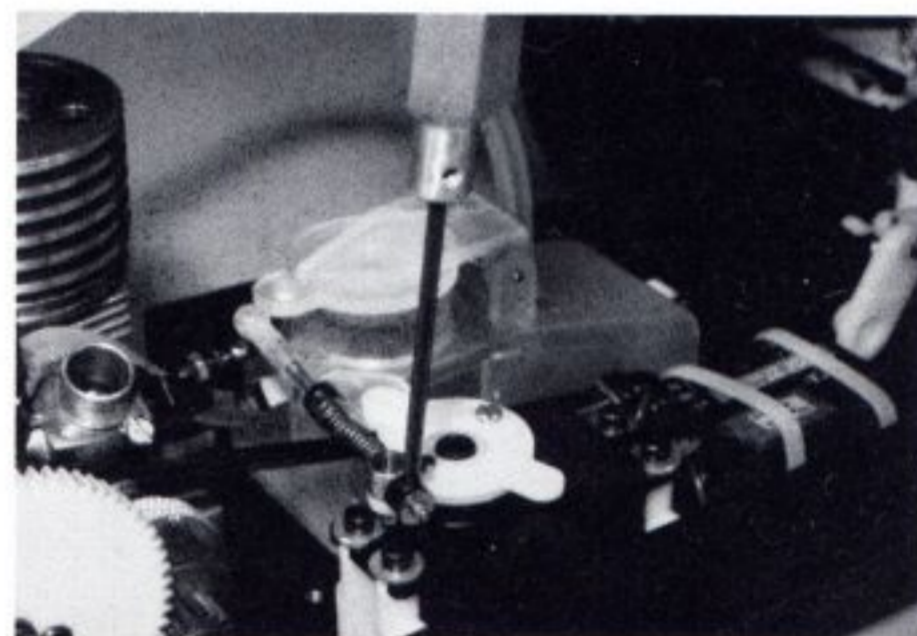

Fig. 273

☐ **Figs. 274-277** Remove the brake linkage parts from bag #7-15 (fig. 274). Install the first collar onto the threaded end and secure it about 3/8" from the end of the threads. Bend the 2-56 threaded rod according to the actual size drawing in fig. 275. Cut off any excess rod below the point indicated. (The angled bend near the end of the brake rod is necessary so the brake rod can clear the throttle linkage without dropping through the #7559 servo horn adapter.) **Warning:** In order to prevent binding or lockup, and to help prevent possible radio interference problems, it is extremely important that the throttle and brake linkage

parts do not touch. Assemble the brake linkage parts in the order shown in figs. 274 & 275. Next drop the bent end of the threaded rod through the hole on the raised end of the #7559 servo horn adapter; install the other .075 collar onto this end of the rod. Be sure to leave a tiny gap so the brake rod cannot bind. Now slide the threaded end through the eyelet on the end of the #7555 brake cam. Now install the #2 steel washer, the #4118 spring and the 2-56 locknut on the other side of the brake cam as shown in fig. 277. We will adjust everything a little later.

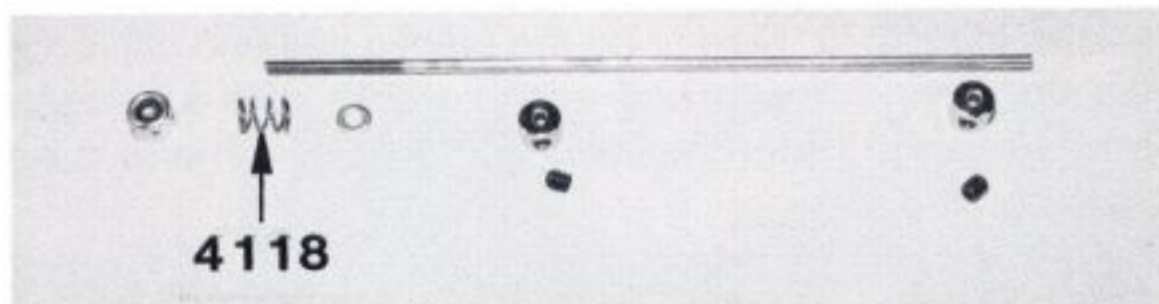
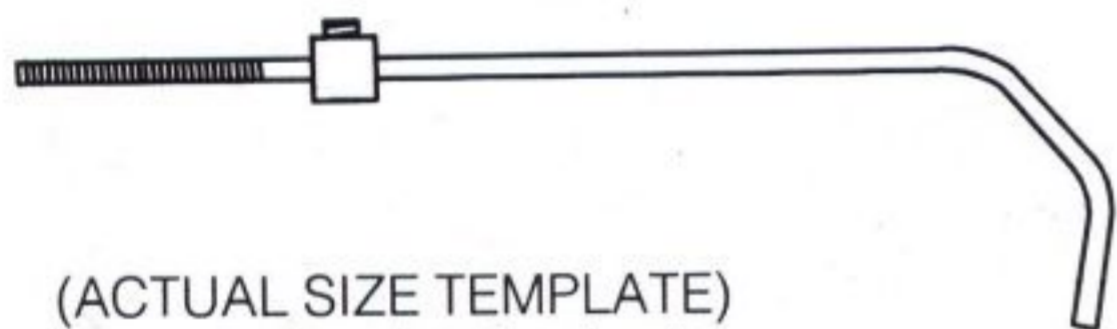

Fig. 274



(ACTUAL SIZE TEMPLATE)

Add collar first, then bend rod to shape and length shown.

Fig. 275

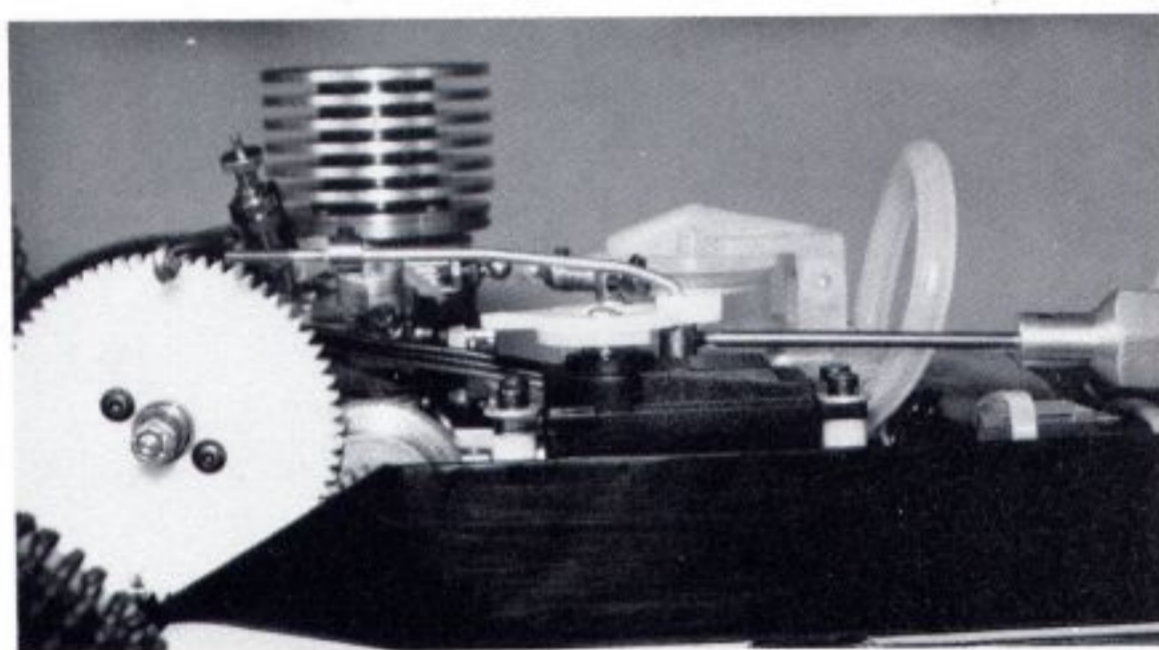

Fig. 276

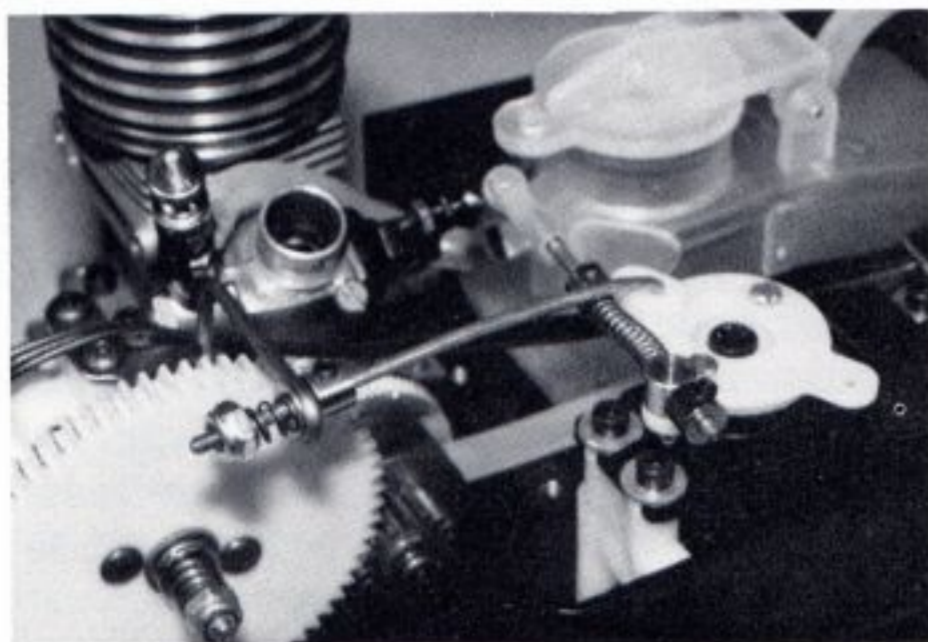

Fig. 277

Fig. 278 & 279 Now we need to remove the #7735 or #7736 exhaust manifold and the two #7738 4-40 x 7/8" SHCScrews (for OS Max & Dynamite) or the two #6928 4-40 x 1" SHCScrews (for Yokomo). You will also need to remove the #7734 exhaust manifold gasket. All of these parts are in the manifold bag. Now bolt your manifold to the engine with the #7734 gasket in between. Use the appropriate #6928 or #7738 screws for your engine. Go ahead and tighten them.

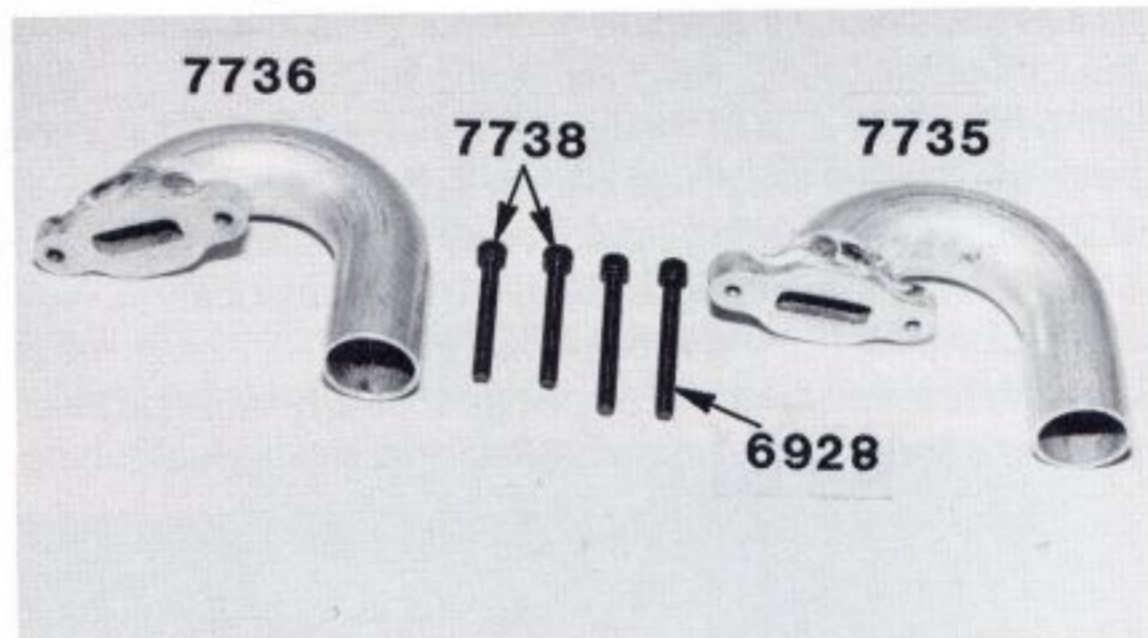

Fig. 278

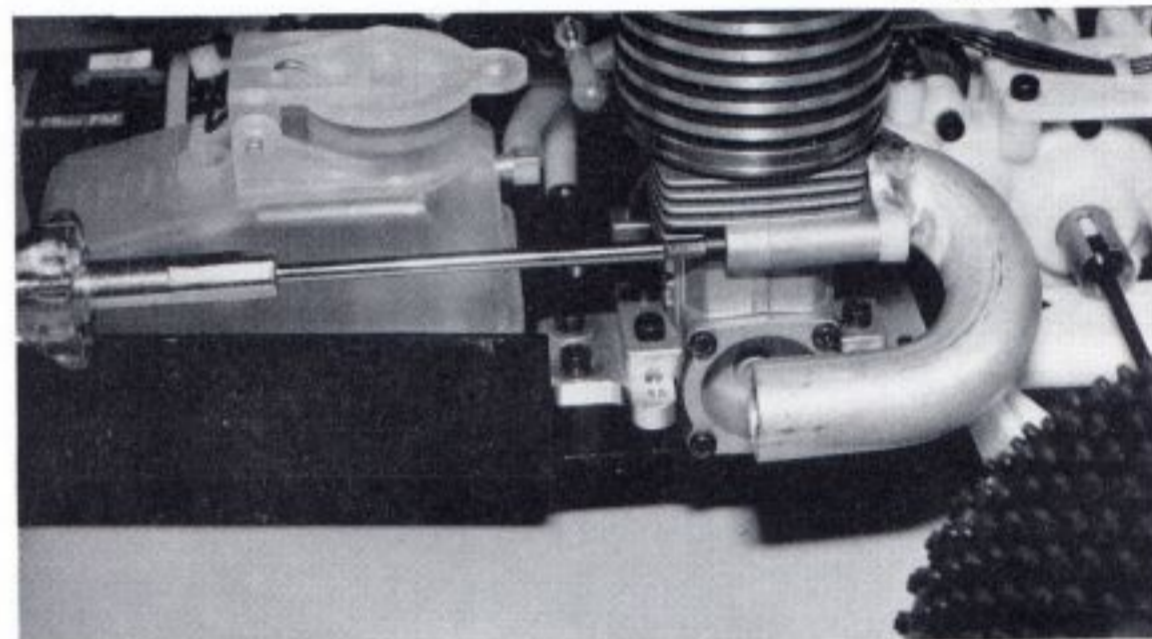

Fig. 279

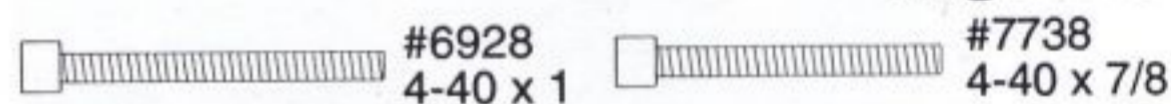

Fig. 280 & 281 Remove the #7733 silicone exhaust tubing and one of the wire ties from the engine accessory pack. Slide the silicone tubing about half way onto the exhaust manifold and then secure it with the wire tie as shown.

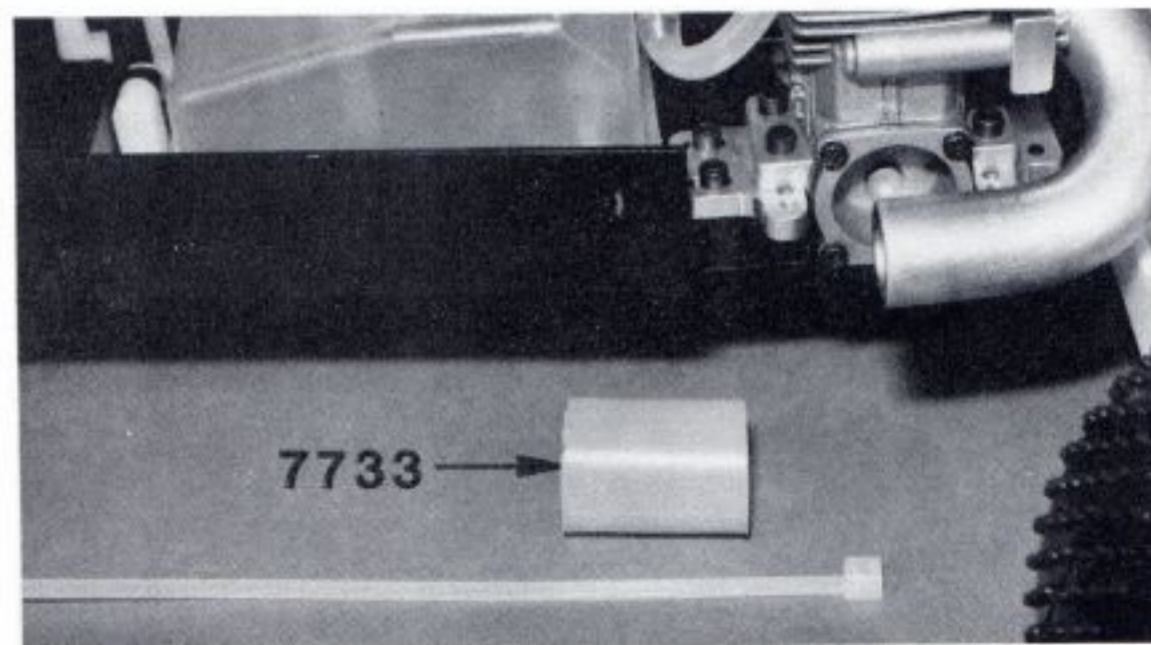

Fig. 280

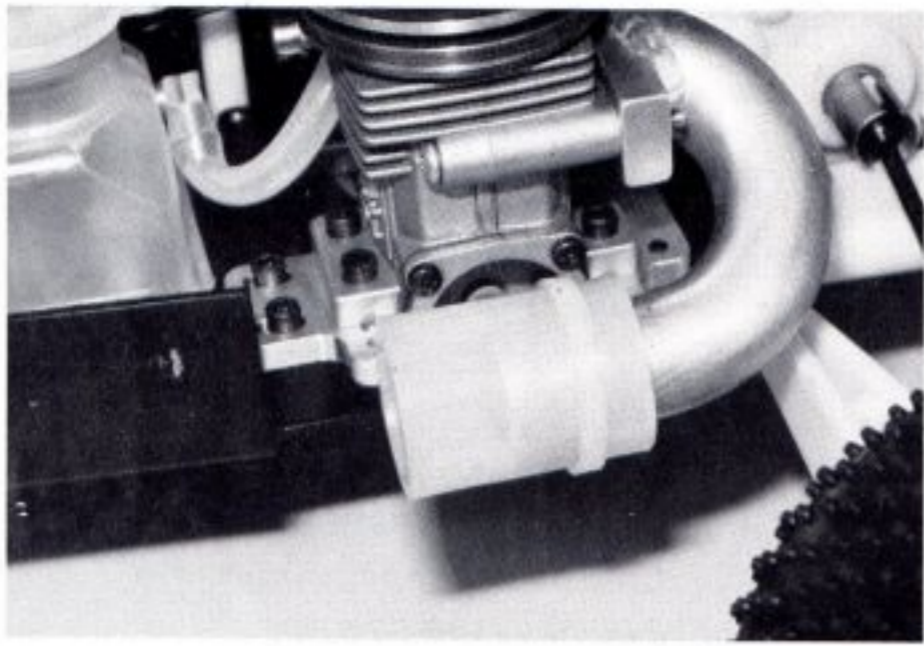

Fig. 281

□ **Figs. 282 & 283** Now we can take out the #7730 tuned pipe muffler and the #7729 muffler bracket and one wire tie from the engine accessory pack. Slip the #7729 bracket onto the muffler so the eyelet is away from the exhaust nozzle (see fig. 283). Now slide the muffler into the exhaust tubing and secure it with the wire tie.

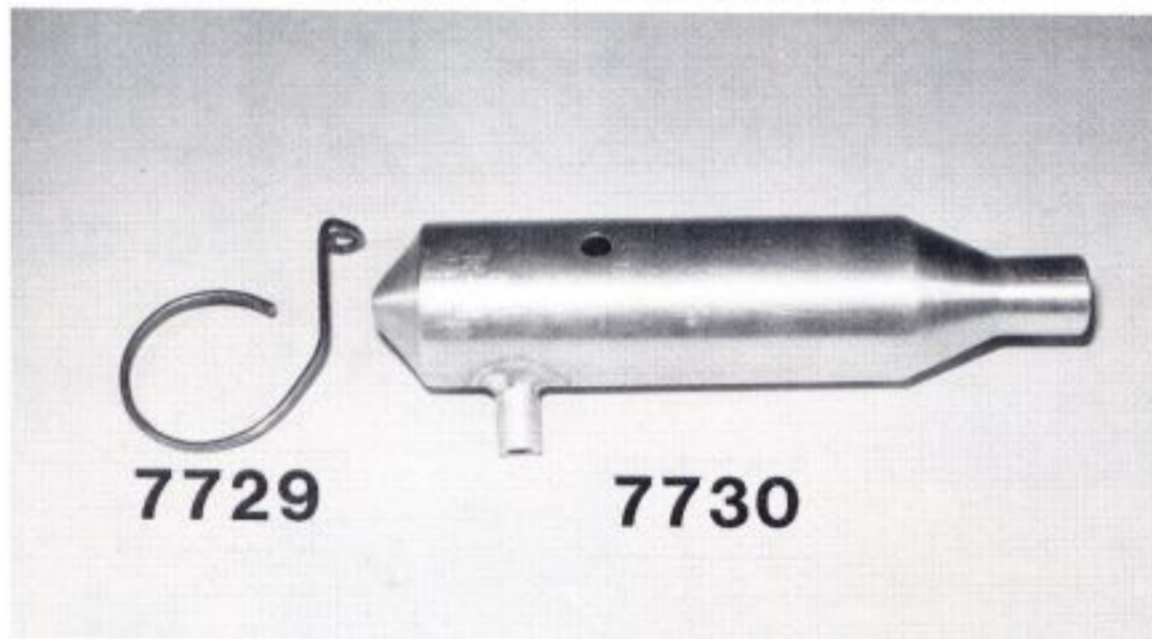

Fig. 282

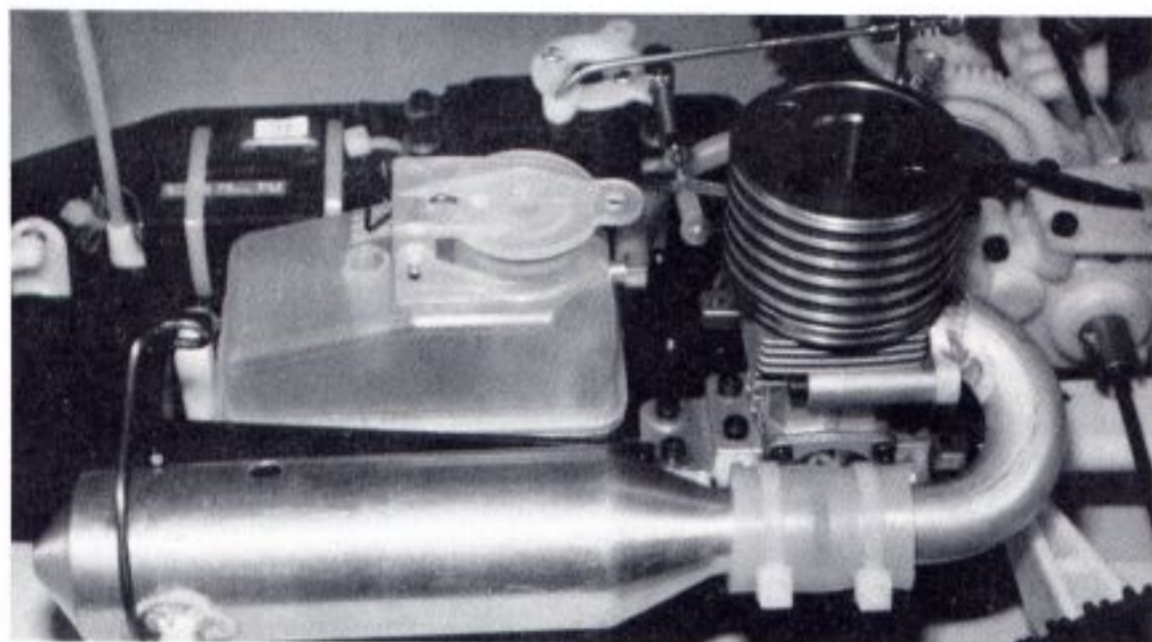

Fig. 283

□ **Figs. 284 & 285** Now remove the #6292 4-40 x 3/8" FHSScrew, one #3216 4-40 steel washer, and one #6242 4-40 locknut from the muffler bag of the engine accessory pack. Next rotate the muffler bracket over the edge of the chassis and move it until it lines up with the hole next to the edge of the chassis. Push the #6292 screws up through the chassis then install the bracket over the threads. Now you can install the #3216 washer and the #6242 locknut, then tighten the screw and nut.

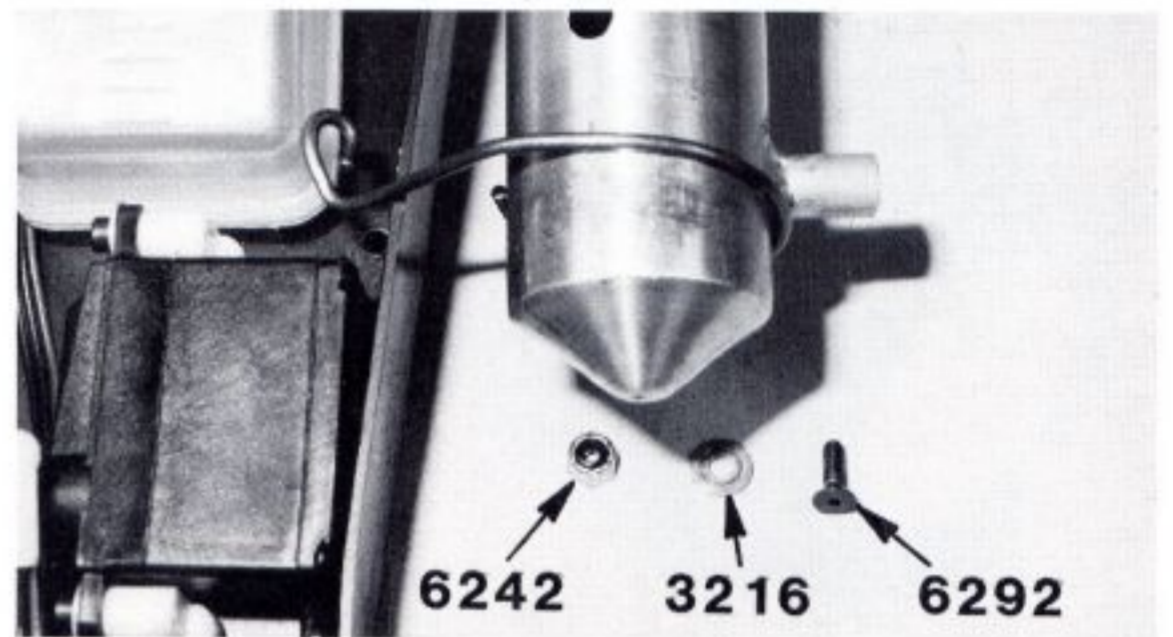

Fig. 284

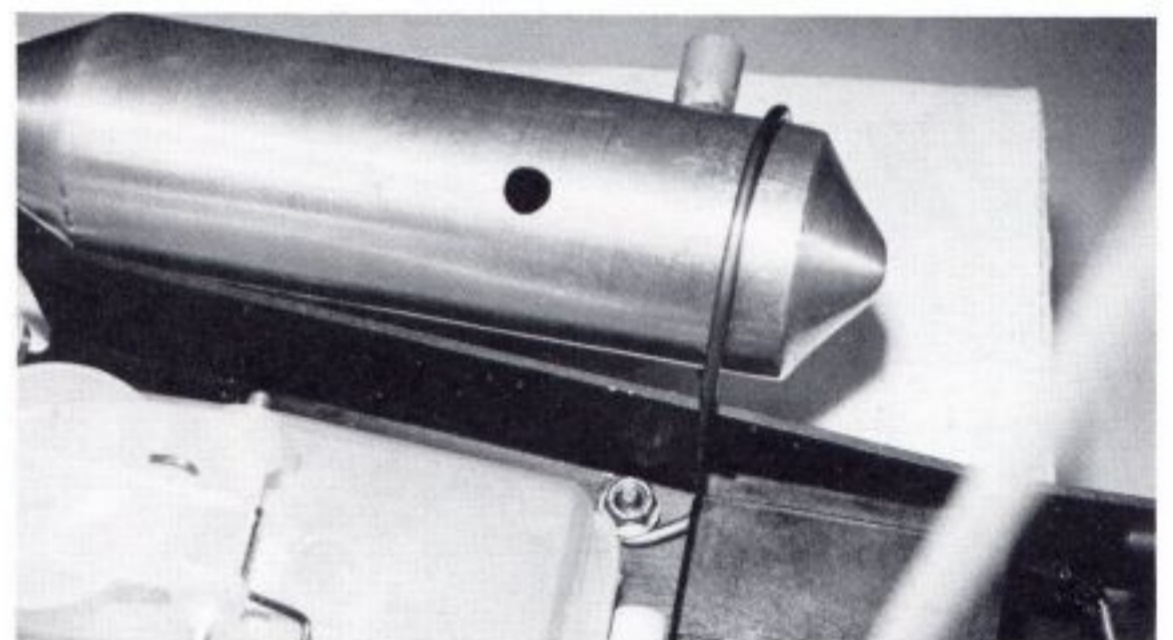

Fig. 285



□ **Figs. 286, 287 & 288** Now we need to get out the remainder of the #7724 fuel tubing for a fuel pressure line. Install the tubing into the fitting on the top of the fuel tank, fig. 286. Take one of the small wire ties from bag #7-7 of the truck kit and loop it around the muffler bracket, leaving as large a loop in it as possible. Take your fuel tubing and run it through the wire tie, then loop it around and bring it back through the same side of the wire tie again, fig. 287. Now take the end of the tubing and squeeze it into the hole in the #7730 tuned pipe muffler about 3/8" where shown in fig. 288. Now tighten up the wire tie so the tie is around the tubing, but not so tight that it will begin to compress the tubing. Cut off the end of the wire tie.

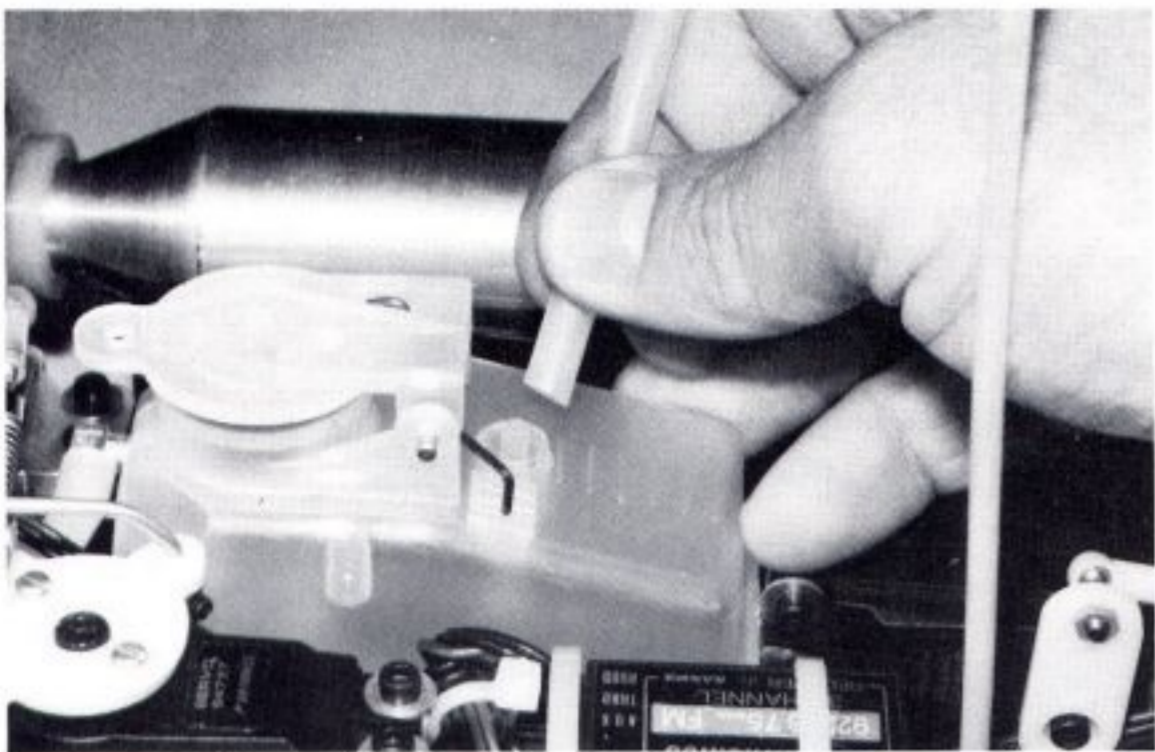

Fig. 286

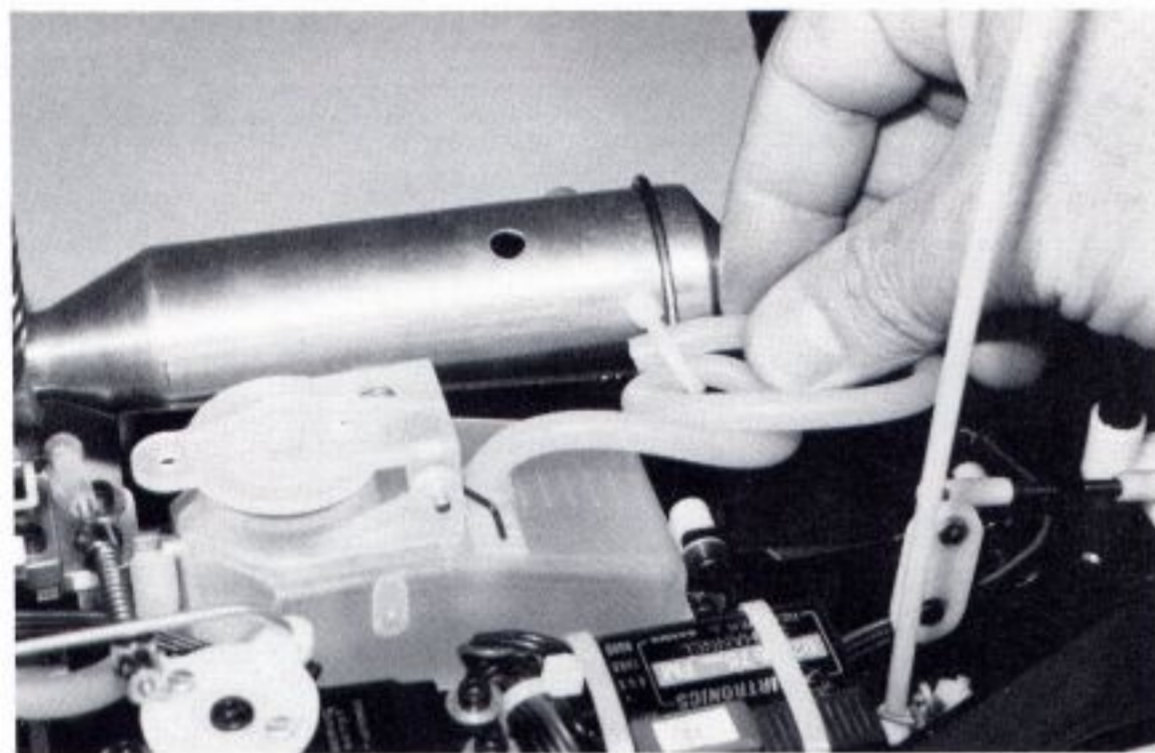

Fig. 287

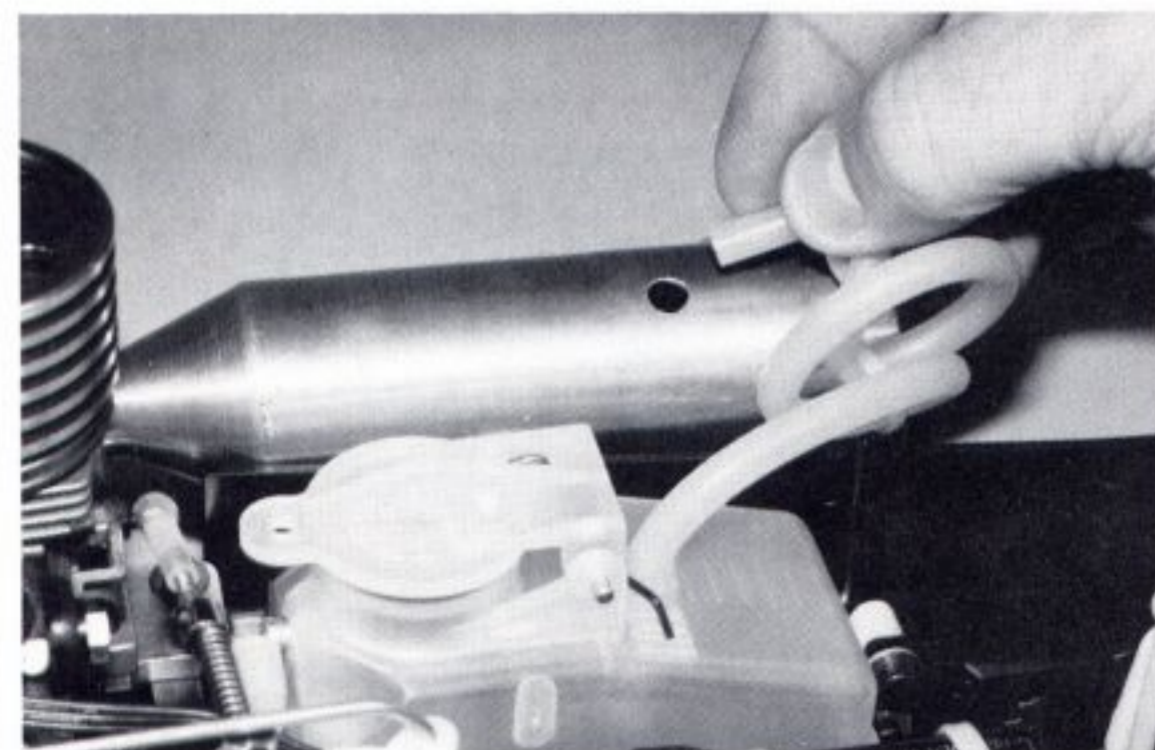

Fig. 288

□ **Figs. 289, 290 & 291** Now take out the #7706 paper air filter element, the #7707 foam prefilter, the #7708 rubber air filter boot, and two small wire ties. These parts will be in a bag in the Engine Installation Pack. The open end of the paper air filter will snap into a groove in the rubber boot. Take one of the small wire ties and secure the filter to the boot, then cut off the wire tie excess. Now slide the foam prefilter over the paper filter element as shown in fig. 290. Fig. 291 shows the air filter assembly on the engine. (After we have finished all of the engine and radio tuning adjustments we will then use the last small wire tie to secure the boot to the carburetor.)

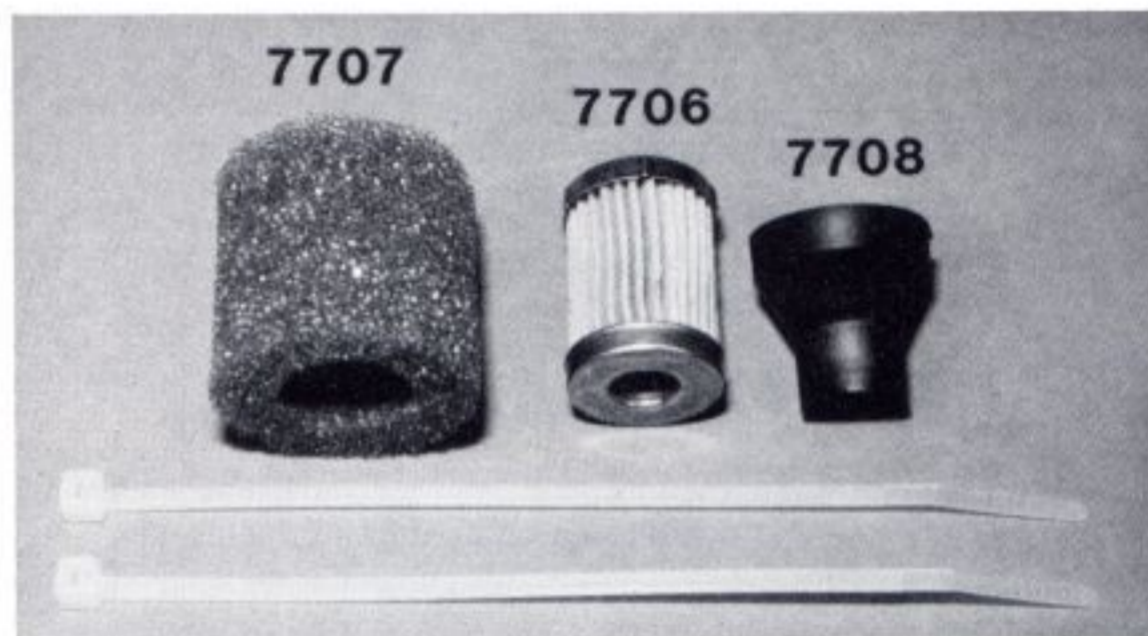

Fig. 289



Fig. 290

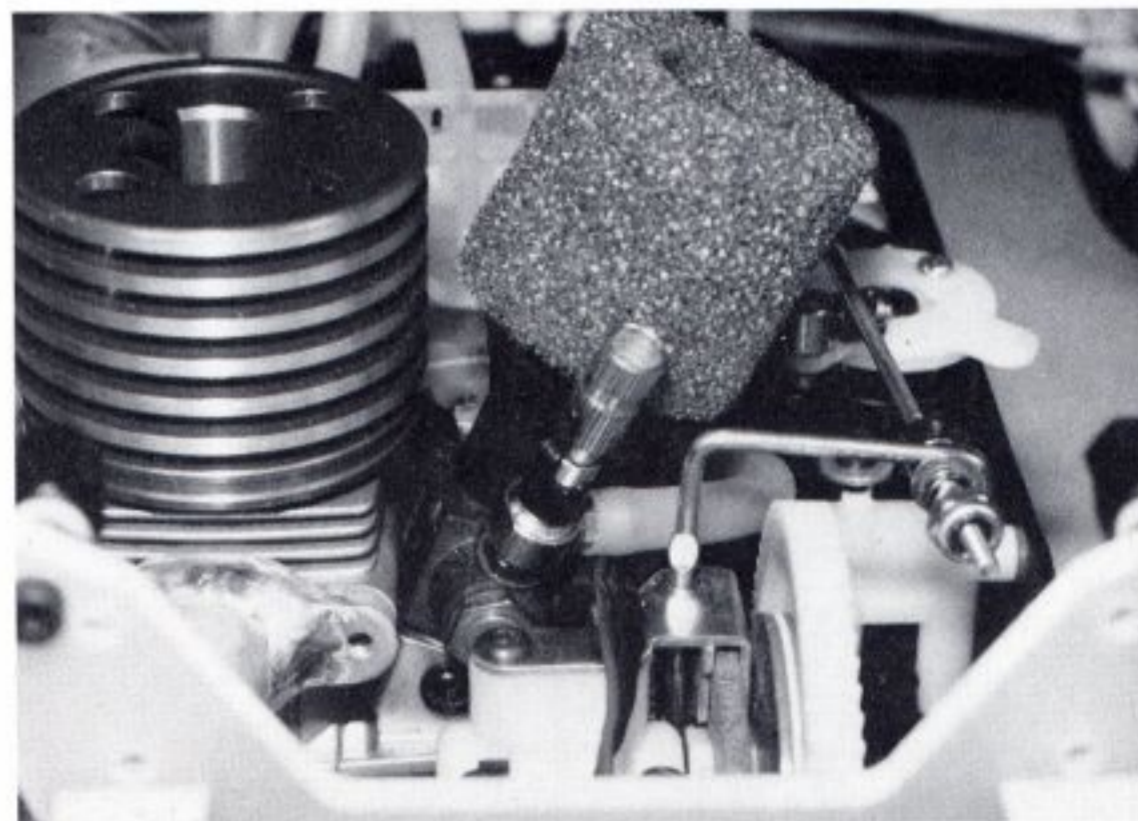

Fig. 291

□ **Fig. 292** This is how your completed truck should look at this time.

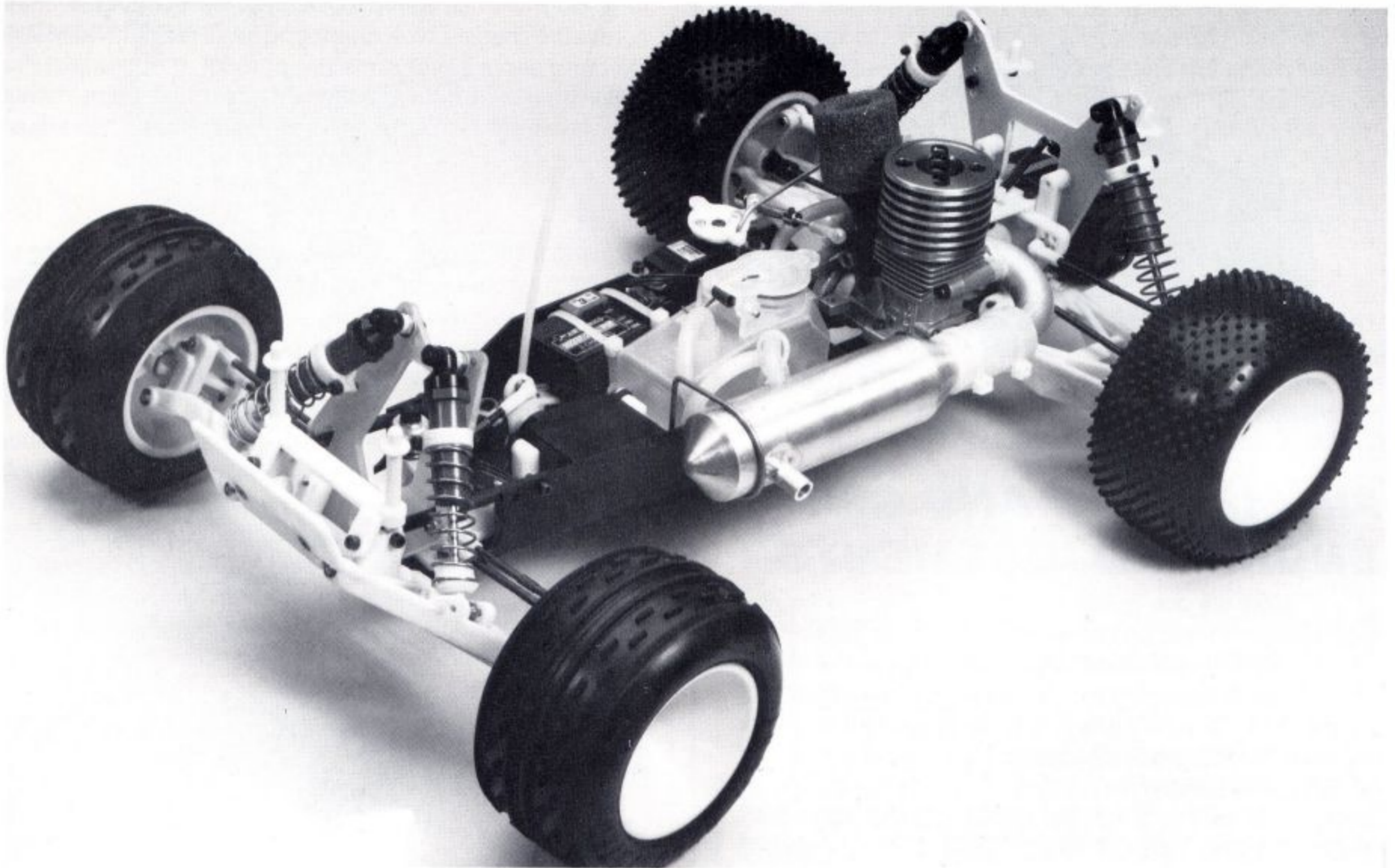

Fig. 292

□ **Figs. 293, 294 & 295** Now we need to do some final trimming on the Lexan truck body. Mount the body on the truck. First mark the body where the exhaust nozzle touches the body. Trim enough around the nozzle so that it does not touch the body while running. Next, trim around the engine cylinder head and the carburetor. This area needs to be cut large enough to allow easy access for the glow plug igniter and to adjust the needle valve. It also has to clear the cylinder head if needed.

We also recommend cutting out the side windows and the windshield to allow maximum air flow to the engine.

Note: If you are going to be racing in either of the racing organizations ROAR and NORRCA, cut only half of the front windshield directly in front of the engine (leaving a place to put your race number). Be sure to round the corners in the windows where you cut them out. This will help to prevent the truck body from cracking prematurely.

If you have not painted your truck body yet, you can go back to the painting section at the end of the truck manual and follow the painting procedures. Be sure to mask over any of the cut out areas so that you do not get overspray on the outside of the body. After you have painted the truck body and made all of your cut-outs you can also detail it.



Fig. 293



Fig. 294



Optional #7185 rear spoiler mounted; not in kit.

Fig. 295

FINAL RADIO AND GAS ENGINE ADJUSTMENTS

Now we are going to check all of our radio and engine adjustments before we start our truck. Make sure your radio transmitter batteries and receiver batteries are fully charged. Also make sure your glow plug igniter is charged or has a good battery. This can require an overnight charge on most radios or igniters, so check your equipment manufacturer's recommendations. We will check all of our adjustments in the following order: **NOTE: YOU CAN REFER TO THE VIDEO TAPE TO ASSIST YOU DURING THE FOLLOWING.**

- Step 1** Turn the transmitter switch on.
- Step 2** Turn on the truck's receiver pack on/off switch.
- Step 3** Turn your steering wheel to the right. See if the front wheels also turn to the right. If they turn to the left, move the steering servo reversing switch to the other position. Follow your radio manufacturer's instructions on how to do this. Recheck to make sure both the radio and the front wheels turn to the right.
- Step 4** After your wheels turn the correct direction, take your hands off of the transmitter steering wheel (or stick). Is the servo horn on the steering servo centered (or in the straight up position)? If it is off just a little bit, you can adjust it using the steering trim knob or wheel on the transmitter. If it is off quite a bit, you must remove the servo horn from the servo and center it so it is in the straight up position. Fine tune with your radio steering trim knob if necessary.
- Step 5** With the servo horn now centered, are your wheels still pointing straight forward? If not, you will need to adjust the length of the steering turnbuckles or servo

turnbuckle. With the servo turnbuckle adjusted correctly, the servo horn will be pointing straight up and the servo arm, on the truck servo saver, will be pointing straight across the chassis. Now check and see if the right hand and left hand servo saver arms are parallel. If not, adjust the small turnbuckle between them. If after these adjustments the wheels are still not pointing straight ahead, then adjust the steering turnbuckles going to the wheels.

Step 6 Set your transmitter throttle travel setting to 70/30. This means you will be using 70 percent of the throttle servo travel for forward and 30 percent of the throttle servo travel for brakes. Use your radio instructions to make this adjustment.

Step 7 With the transmitter still on, look at your #7559 servo horn adapter. Its neutral position should look like fig. 296. If not, remove the servo horn mounting screw and lift the servo horn assembly and rotate it until you find a spline that will line up according to the photo or as close as possible. You can use your throttle trim knob to make any fine tuning adjustments. You can now tighten the servo horn mounting screw.

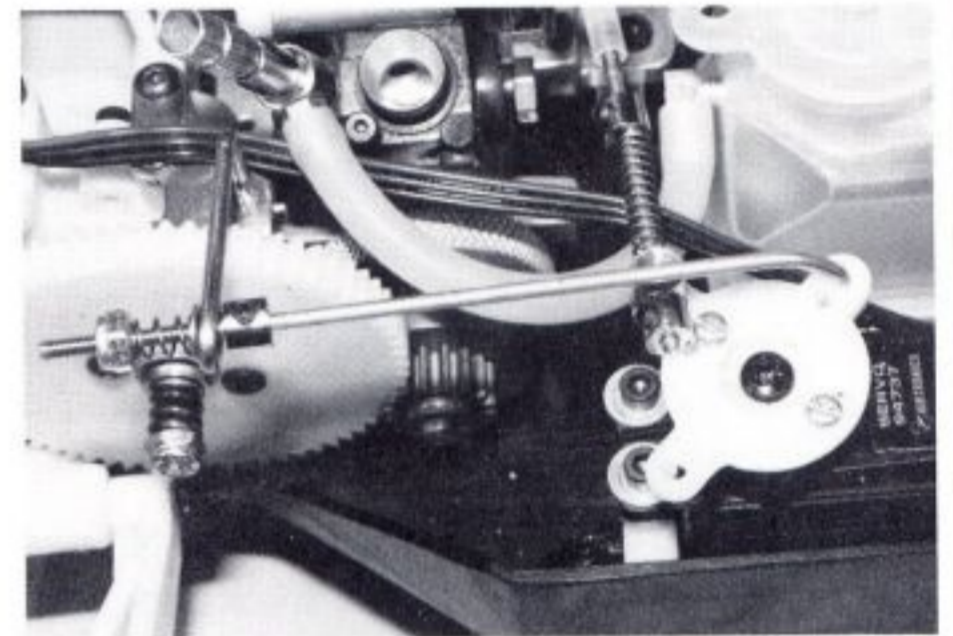

Fig. 296

Step 8 In figs. 297A and 297B we have removed a carburetor so we can show you where each adjustment point is. (You can make any needed adjustments while the carburetor is mounted on the car.) We will show you how to adjust these features a little later. On the left is the needle valve assembly. This is your high speed fuel mixture adjustment control. The screwdriver is touching the low speed/idle fuel mixture adjustment screw. These two adjustments richen and lean the air/fuel mixture when turned in the direction shown in fig. 297B.

On the front of the carb you will find a very small screw called the idle air speed adjustment screw. Turn this until the throttle opening inside the throttle valve assembly is 1/32". Slip your 1/32" piano wire (from the air filter bag) into the half-moon shaped opening to gauge the opening.

Check and make sure your needle valve setting is adjusted according to the engine manufacturer's instructions. Set your idle mixture screw according to the manufacturer's engine manual. If you find nothing in their

manual about the idle mixture adjustment, then leave the settings as it came from the factory for now. We need to make all of these adjustments before we can adjust the carburetor linkage.

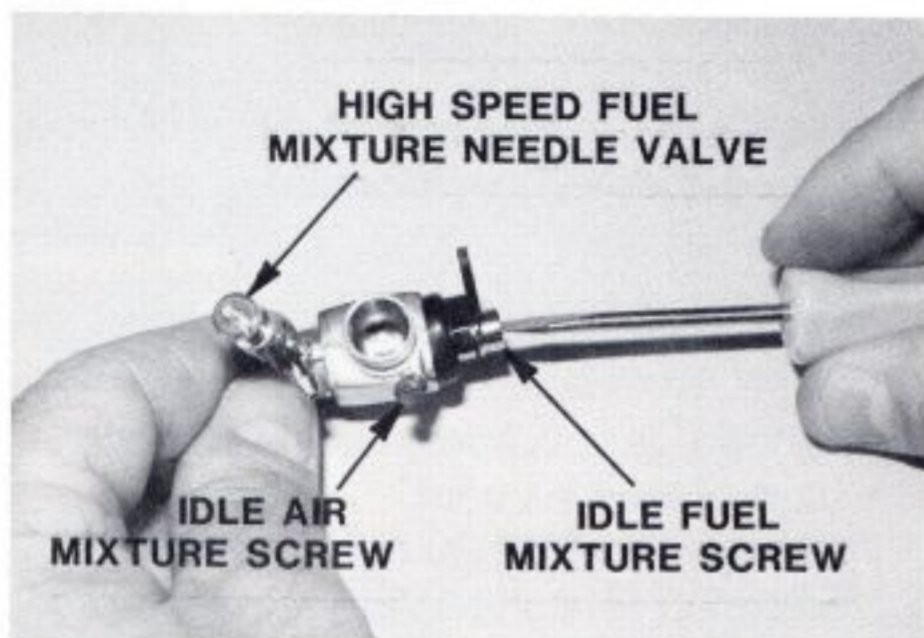

Fig. 297A

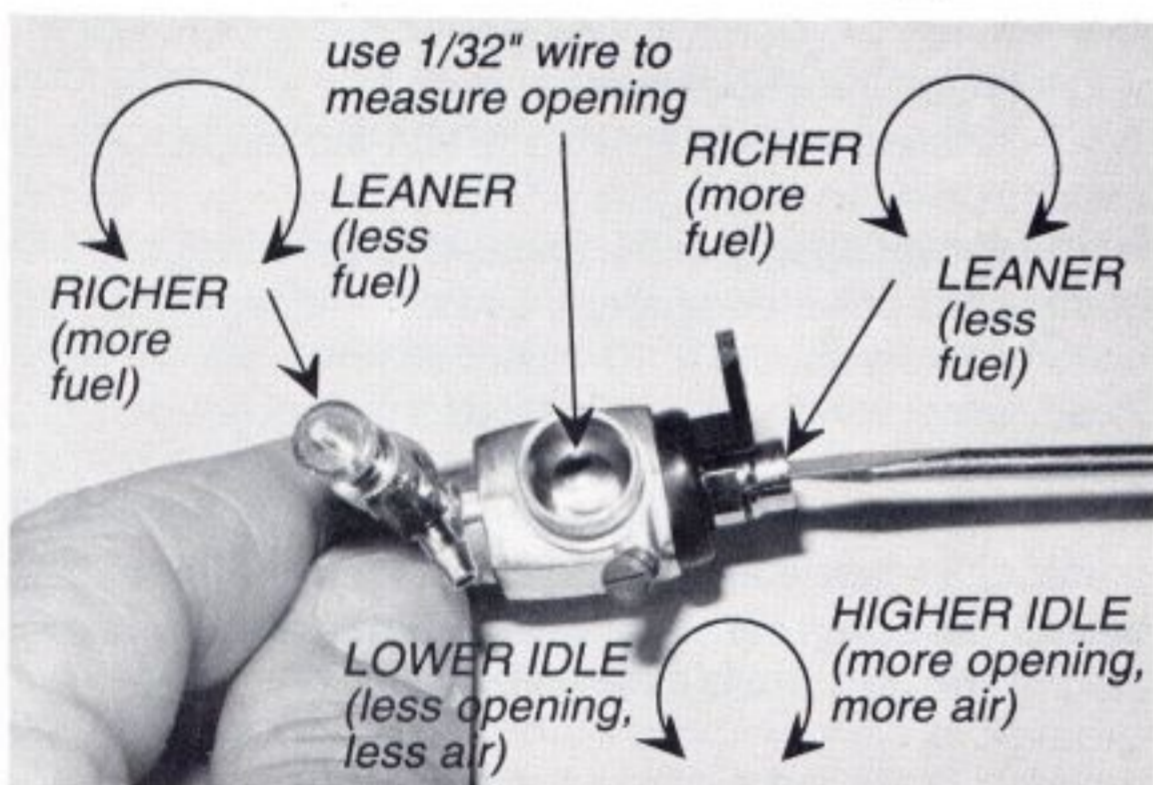

Fig. 297B

Step 9 Push closed the carburetor throttle pivot arm on the engine (by hand if necessary, fig. 284). With the throttle closed, adjust the outside collar on the throttle rod so that there is a gap of 1/16" between the #7557 aluminum throttle pivot and the collar. Now squeeze and release the throttle trigger on the transmitter. We need to adjust the inside collar (next to the spring) so that when we let off on the throttle trigger the spring is tight enough to close the carburetor. If it does not fully close the carb, move the collar next to the spring so that you compress the spring more. Get the spring set so it just closes the carburetor but you do not want it any tighter than this. If there is any excess throttle rod sticking out past the outside collar, cut it off, but leave about 1/32" past the collar.

Step 10 Now move the transmitter throttle to the full position. Does the throttle valve open fully? If not you will need to shorten the length of the throttle rod by threading the plastic ball end on further. Now recheck the full throttle opening. If you had to adjust the rod length we also recommend you go back to step 8 and double check all of the adjustments up to this point.

Step 11 To adjust the brake, fig. 288, make sure the #7555 brake cam arm resting in its forward position (but with no pressure on it). Also make sure the transmitter throttle position is at neutral. There should be a 1/16" gap between the cam arm and the collar. Now tighten the 2-56 locknut so that there is no play between the spring and the nut. After we have the engine running we will want to have the brake adjusting nut just tight enough so that when the truck is idling the brake will just barely keep the truck from moving. To increase the brake, you tighten the locknut against the spring more.

Step 12 If your motor does not come with a glow plug you will need to purchase one. Take your glow plug wrench or 5/16" nut driver and install the glow plug into the cylinder head. They normally come with a brass washer, so make sure you did not forget to install it as well. Just hand tighten the glow plug into the cylinder head. At the present time, for glow plugs, we recommend either the McCoy #MC-104-9 or the OS Max #8. These are good quality plugs and have the correct heat range for R/C cars and trucks.

Step 13 Figs. 298A-298D show what each of the needed items or accessories normally look like. They are labeled to help you identify what each item is. Their use is described in the following instructions if you are unfamiliar with them. Fig. 298A shows a long reach glow plug igniter, Ni-cad style. Fig. 298B show a hand starter motor with car type rubber donut (Associated #SP-26) and a 12 volt battery used to run it. Fig. 298C (next page) shows an

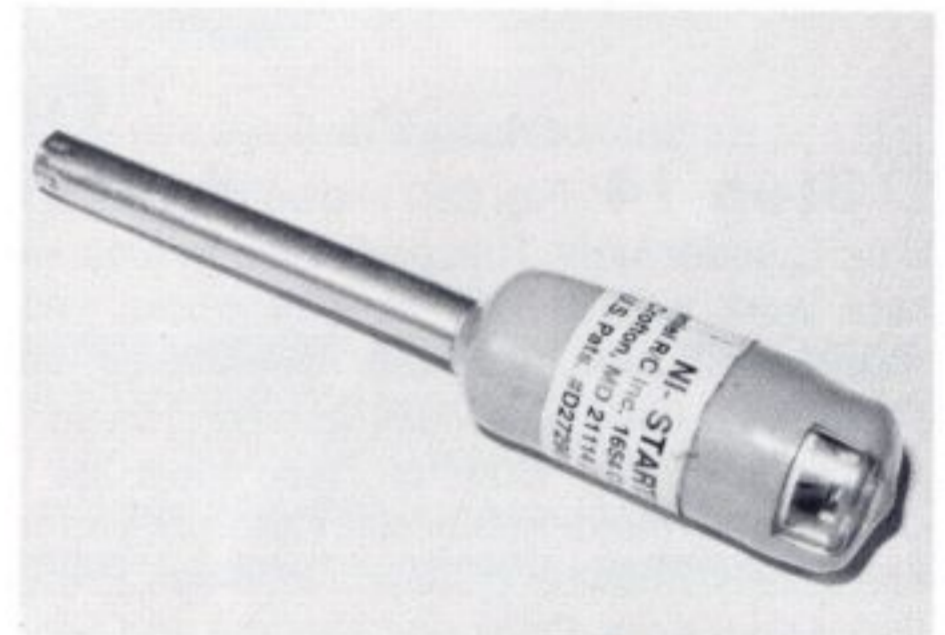

Fig. 298A

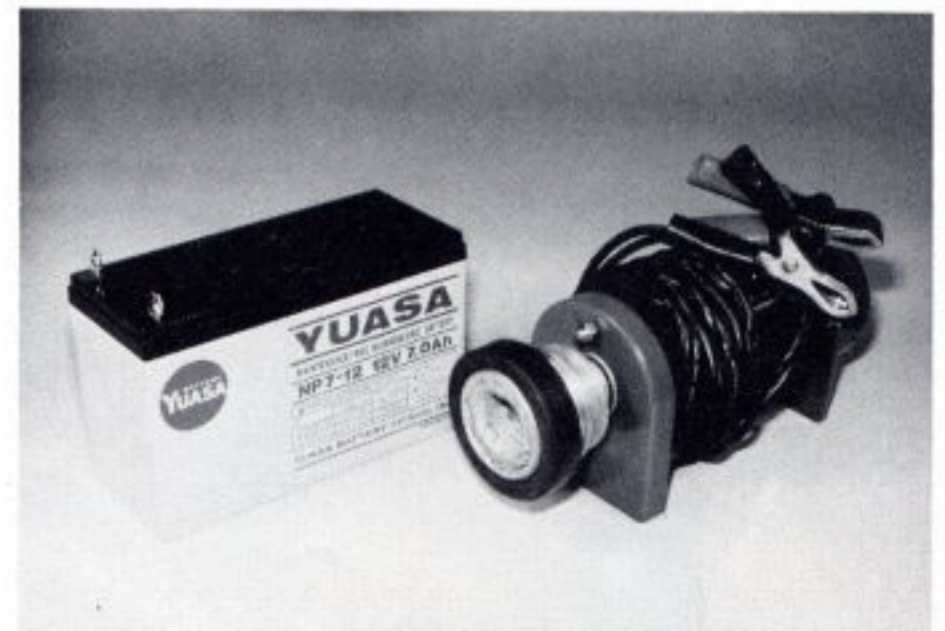

Fig. 298B

optional starter box with enclosed battery. Fig. 298D shows installing one inch piece of fuel tubing on pull start cord. You can either untie the knot and slide the tubing on, or you can slice the tubing, slip it around the cord, and tape it closed. This raises the pull start handle above the exhaust manifold.

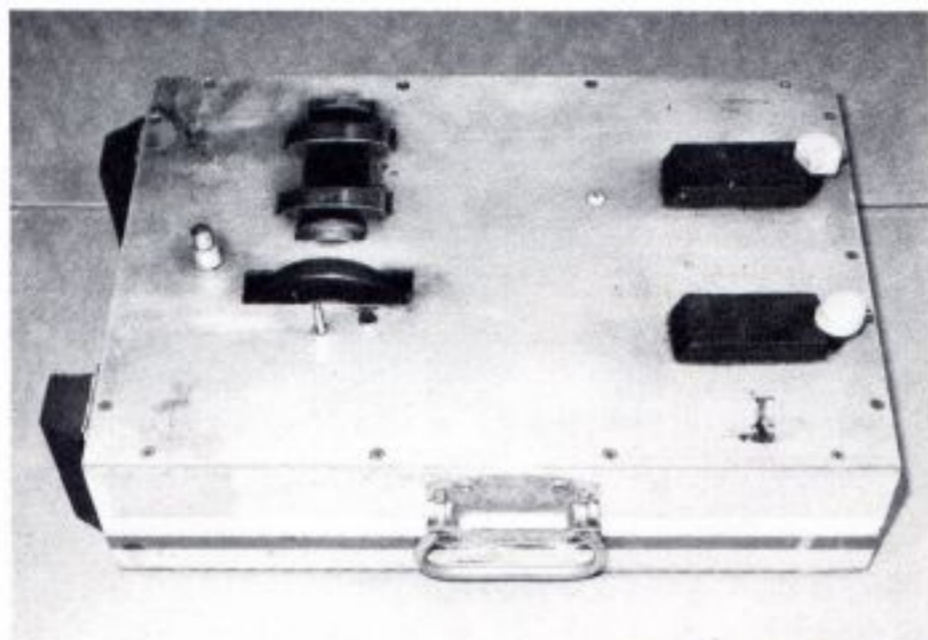

Fig. 298C



Fig. 298D

Step 14 Fig. 299 shows both the O'Donnell and Blue Thunder fuels. These are the only fuels we can say for sure work well in R/C cars or trucks. **Warning:** We recommend only the O'Donnell or Blue Thunder fuels because we have personally raced with these fuels and can verify the quality. Both of these fuels are available to dealers from major hobby distributors. If you cannot locate these fuels, it will be up to you to locate a reliable R/C car fuel in your area. Don't use airplane and helicopter fuels; they do not have the necessary oil types and ratios for R/



Fig. 299

C cars. They have a greater amount of cooling air across the engine, allowing them to use different oils in their fuel. Gas engine cars and trucks, which have a much more restricted amount of air flow over the engine, need different oils in the fuel to help handle the higher engine temperatures. Check with local car and truck racers or hobbyists and see what they have found that performs well. We also recommend only a maximum of 20 percent nitro in the fuel.

Now get out your O'Donnell or Blue Thunder fuel and your fuel fill bottle. Put a couple of ounces of fuel into your fuel fill bottle so we will have enough for the first tank full of fuel. Go ahead and open the quick fill top on the fuel tank and fill the tank from your fuel fill bottle. Fill the tank to the base of the tank neck.

Step 15 If you have a non-pull start motor you will need to get out your hand starter (with rubber starter donut or wheel) or starter box and the battery that you are going to use to run the starter. If you have a pull start motor you will not need the above items.

Before we will be able to run the engine we will need to prime the fuel system. The easiest way to do this is to put your finger over the exhaust nozzle on the muffler and pull the pull starter cord a couple of times or turn the engine over for about 5 to 10 seconds with the starter motor. If you are not familiar with using starter motors you can refer to step 17.

Watch the fuel line that goes from the fuel tank to the carb. When you see the fuel reach the carburetor needle valve, you can stop. **Note:** This is without the glow plug igniter connected to the engine.

Step 16 Now get out your glow plug igniter unit. Make sure it is one of the long reach models so that it can reach the glow plug at the bottom of the heat sink cylinder head on the motor. We personally recommend the Ni-cad type of glow plug starters so that you don't have any additional wires dangling around when you are starting the engine. If you are using one of the older wired igniters you will also need a 1.5 volt dry cell battery to run the igniter.

Step 17 If you are going to be using a starter motor, fig. 300 shows where the cutout in the bottom of the chassis is located around the flywheel. Go ahead and get the starter set up and ready to go. To use it, you will need to bump the starter motor rubber donut against the flywheel, through this opening, and then hold it there after the motor starts to turn over. **WARNING!** the flywheel on the engine must rotate counter clockwise (when looked at from the clutch end) in order to work correctly. Check the direction of rotation of the starter motor rubber donut when placed under the chassis. If it was brought in from the clutch side it should rotate clockwise. If the rotation is backwards you will need to bring the starter motor in from the other side of the chassis or reverse the starter motor connections to the battery.

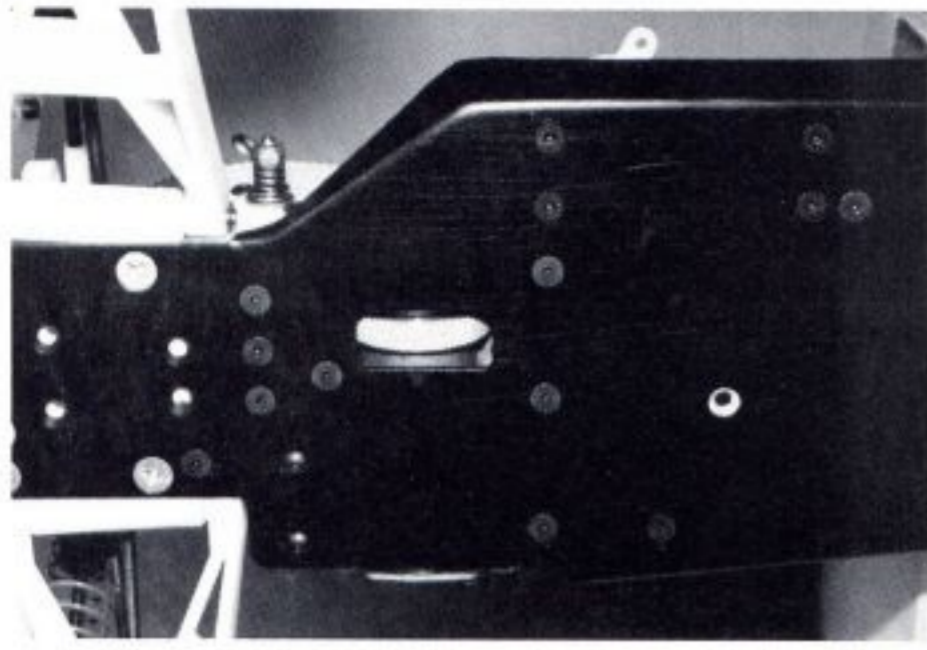

Fig. 300

Step 18 We are now ready to start the engine for the first time. Make sure the radio transmitter and receiver battery are still on. Connect your glow plug igniter to the glow plug. Now try and start your engine. If your adjustments are set according to the manuals for your engine and/or carburetor, the engine should start after a few attempts. When you have the engine running, give it a little more throttle to help clear the carburetor. Let the engine warm up for at least 20 to 30 seconds before you remove the glow plug igniter. The engine should idle easily. If the rpms increase and then the engine shuts off, the idle mixture is a little lean. Open the idle mixture fuel screw about 1/8 of a turn counter clockwise and then try again. Keep making these adjustments until the engine idles and doesn't rev up and shut off. If the engine does not idle or idles then sounds like it is blubbering before it shuts off, you will need to decrease the idle fuel mixture a small amount. Tighten the idle mixture screw about 1/8 of a turn clockwise and then try again. Keep making these adjustments until the engine idles and does not bog down and shut off.

Step 19 Now we need to check the truck for possible radio interference. Go ahead and rev the engine several times but look closely at the truck for any signs of radio interference. If everything looks okay, have someone hold your truck in the air, then pull up your antenna and then slowly walk away from the truck. If everything is still okay, you will not see any erratic movements from the truck as you turn the steering wheel or move the throttle. Work your way away from the truck to a distance that equals the distance you know the truck will be away from you when you are using it. Once you have verified that you are not having radio problems you are now ready put the truck on the ground and see how it runs.

Step 20 With the truck on the ground we need to check the brake at idle. If the truck is moving or attempting to move, tighten the brake locknut a tiny amount. Now give the truck some throttle, then apply the brakes. Does the truck seem to stop correctly? Do this at several throttle speeds just to be sure.

Step 21 The engine has been running long enough to be completely warm. Now we need to check the high

speed fuel adjustment. We want to break in a new engine correctly to give us the longest engine life possible. For the first two or three tanks of fuel, run the engine a little on the rich side (as explained in step 8). This will help to break in the engine without doing damage to the internal parts. The engine during break in should be close to blubbering and there should be a fair amount of smoke coming out of the muffler. During the break in period your run time will be very short because you are not burning all of the fuel.

After we have run our break in tanks of fuel we can now begin to adjust the carburetor for the correct mixture at high speed. Go ahead and run the truck up and down the track surface at high speed. If the high speed fuel mixture is too rich you will see a lot of smoke, hear a blubbering sound or a lower engine tone. Adjust the needle valve assembly clockwise 1/8 of a turn. If the engine mixture is too lean at high speed the engine will shut off or have a very high pitch tone (almost tinny sounding). Adjust the needle valve assembly counter clockwise 1/8 of a turn. You should always see smoke coming out of your muffler.

Step 22 Now shut off the engine. You can accomplish this in several ways: you can block off the exhaust nozzle on the muffler with a rag (not just cover it but block it off). **Warning! the muffler can be extremely hot so be careful any time you touch it..** You can pinch off the fuel line from the tank. Or, with the engine at idle, you can stop the flywheel with your shoe or a rag from the bottom of the chassis. **Do not use your hand or fingers to attempt to stop the flywheel.** After you have stopped the engine, turn off the receiver pack on/off switch.

Step 23 Now turn off the transmitter on/off switch. This switch is always the **first switch turned on and the last switch turned off.**

CONGRATULATIONS!! You now have a fully operational gas powered off road truck. Give yourself a pat on the back and go out and have fun with your new truck!

RC10GT TRUCK MAINTENANCE

You will find your RC10GT truck will give you many more hours of trouble-free operation than any other gas truck now available. Even so, you should periodically check all the moving parts: front and rear A-arms, steering blocks, steering linkage, servo saver, shocks, clutch, brake parts and so on. If any of these parts should get any dirt in the moving or pivoting parts locations, it can reduce the truck's handling or performance.

The easiest way to keep your gas truck clean is with a small paint brush and or tooth brush. This will help

you to get to dirt or mud in just about any location on the truck.

DIFFERENTIAL MAINTENANCE

When the truck is ready to run (battery and motor installed and charged), apply a small amount of throttle while holding one of the rear wheels stationary. Do this for about 15 seconds. This will correctly seat all of the differential parts. Now readjust the differential by bottoming its spring and screw and backing the screw out 1/4 turn.

You should rebuild the differential when the action gets somewhat "gritty" feeling. Usually cleaning and applying new lube according to the instructions will bring it back to new condition. The tungsten carbide diff balls (which are standard parts) should rarely need changing. Normally as the parts seat, the diff will get smoother. If after carefully cleaning and relubing the diff parts, the diff still feels gritty, the parts should be replaced in the following order: #6573 thrust washers, #6574 5/64" precision diff thrust balls, #7666 diff drive rings. Only after all of these parts have been replaced and the diff smoothness has not improved should you consider replacing the #6581 3/32" carbide diff balls. Refer to the diff assembly section of your manual to correctly reassemble the diff.

WARNING! Do not oil or lube the gear inside the transmission. The gears are made of a self-lubricating material. Any oil or lube on the gears could get to the differential and cause failure of the diff due to slippage!

RADIO MAINTENANCE

A radio problem is not always caused strictly by the radio system. Often it is caused by a combination of several factors which can include: bad connections or chaffed wires, reversed or defective crystals, shortened receiver antenna wire or low receiver pack voltage. If your radio problem persists you can try the following suggestions:

Try a different radio frequency (change crystals).

Try a different radio receiver

Try mounting the receiver on its side with the crystal up.

Do you have any excess antenna wire bundled next to the chassis? If you do, try placing it on top of the receiver away from the chassis.

Make sure the servo wires are away from the antenna wire.

Make sure that no wires cross the antenna wire.

Note that you can also run into outside interference at times; the 75mhz radio band will tend to be more susceptible to this problem than the 27mhz band. An AM transmitter will tend to have more problems than an FM transmitter. Large metal objects such as chain link fences, light poles, cars, vans, trailers or even fluorescent lights can occasionally cause local interference by momentarily blocking or reflecting a signal.

TUNING TIPS

Several different adjustments on your RC10GT truck can help you adjust steering, traction, and handling for different track conditions.

ENGINE CLUTCH (Fig. 301A & 301B) The clutch shoes and spring for your gas engine is designed to be adjusted for different track conditions and/or driving styles. The clutch shoes have four different holes in them; by moving the spring to the different holes you will increase or decrease how fast the clutch shoes will fully engage. If you move the spring closer to the flywheel pins (where the clutch shoes pivot from, fig. 301B), the shoes will be able to expand quicker and then grab sooner. If you move the spring away from the flywheel pins (fig. 301A) it will take longer for the clutch to fully engage. Keep in mind that the quicker the clutch shoes engage, the more likely you will develop tire spin on the track.

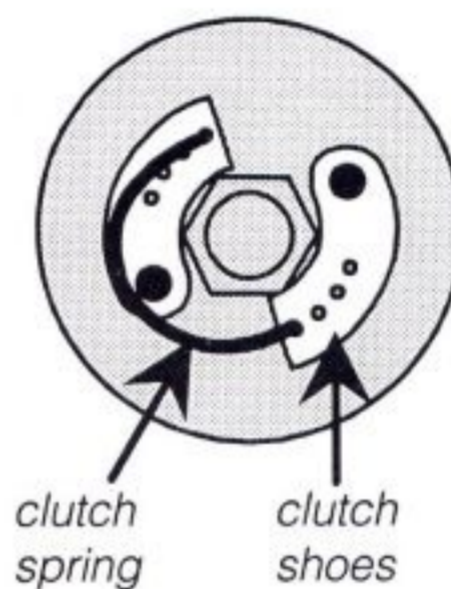

slower engagement

Fig. 301A

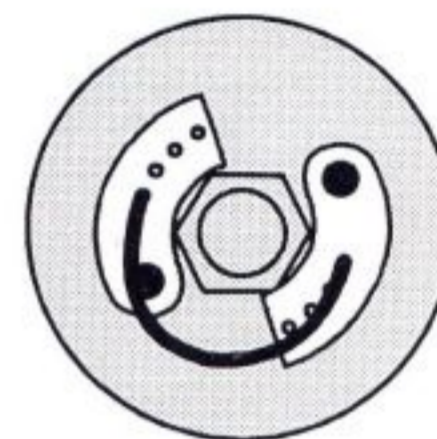

faster engagement

Fig. 301B

CASTER (fig. 302) describes the angle of the kingpin, in relation to the vertical plane, when looked at from the side of the car. As an example, 0° of caster puts the kingpin in a vertical line. Positive caster means the kingpin leans rearward at the top.

Caster has several effects; however, the easiest way to see its effects is to compare it to the casters on the bottom of a shopping cart. When the cart is pushed forward, any misalignment of the casters will cause a side load on the wheels and thus cause the wheels to realign in the direction of travel. Increasing the positive caster on your car will increase the steering turning into a corner and slightly increase understeer coming out of the corner. Reducing the positive caster will decrease the amount of steering you have going into a corner and increase the amount of steering you have in the middle of the corner and exiting the same corner. Associated makes positive caster blocks in increments of 5° starting at 5° and going through 30°. Your RC10T Team truck comes with our new 30°

slightly increase understeer coming out of the corner. Reducing the positive caster will decrease the amount of steering you have going into a corner and increase the amount of steering you have in the middle of the corner and exiting the same corner. Associated makes positive caster blocks in increments of 5° starting at 5° and going through 30°. Your RC10T Team truck comes with our new 30° caster, front carrier blocks, which is what we recommend for off road racing. The 30° of caster will give you good steering going into the corner but take away just enough steering coming out of the corner so that the truck will have less tendency to oversteer when accelerating out of the corner. The increased caster also gives you more stability on fast, bumpy track conditions.

Caster summary:

CASTER:



negative
caster (not
used)



30° positive
caster

ADJUSTMENT:

Change front block carriers.

EFFECT:

Reducing caster: decreases steering into corners, increases steering at middle and end of corners.

Increasing caster: Increased steering at beginning of corners, more understeer out of corners.

RECOMMENDED: 30° caster.

POSITIVE CASTER OPTIONS:

- #6211 Front block carrier, 5° caster.
- #6212 Front block carrier, 10° caster.
- #6213 Front block carrier, 15° caster.
- #6214 Front block carrier, 20° caster.
- #6215 Front block carrier, 25° caster.
- #6210 Front block carrier, 30° caster, included in kit.

Fig. 302

CAMBER is a word describing the angle at which the tire and wheel rides relative to the ground when looked at from the front or back (fig. 303). This is one of the most important adjustments on the truck. Negative camber means that the tire leans inward at the top, putting it closer to the centerline of the car than the bottom of the tire. Positive camber means just the opposite, the top of the tire is further away from the centerline of the car than the bottom of the tire.

Negative camber will take away traction but increase stability. Positive camber will also take away traction but decrease stability. A tire's maximum traction is achieved when it is perpendicular to the ground (straight up and down). For the rear tires this will cause understeering in most conditions and possibly traction rolling in high traction conditions. We suggest a starting setting of 2° of negative camber for both front and rear. If you want to add a little more steering, reduce front camber to 1° negative or even 0°. Keep in mind that using little or 0° of camber will cause the truck to slide unpredictably. Try to use at least 1 to 2° negative camber at all times. This can be adjusted by turning the upper control rod turnbuckles (front or rear) in the appropriate direction.

Camber summary:

CAMBER:

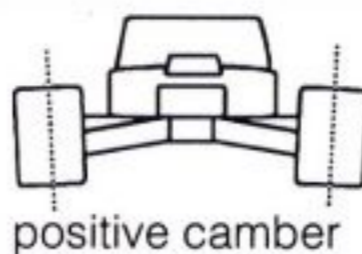

positive camber

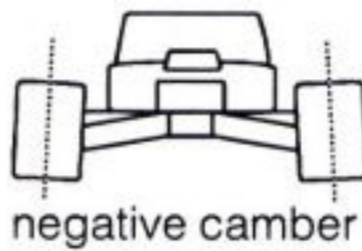

negative camber

Fig. 303

ADJUSTMENT:

Turn upper control rod turnbuckles.

EFFECT:

Negative: less traction, more stability.

Positive: less traction, less stability.

None: maximum traction.

RECOMMENDED: 2° negative camber front and rear.

TOE-IN AND TOE OUT is a very helpful adjustment (fig. 304). It applies to both the front and the back of the vehicle and has the following effects. Adding toe-in to the front tires helps stabilize your truck under acceleration but at the same time it removes a small amount of turn-in steering. Toe-out will add turn-in steering but will reduce stability under acceleration or through the bumps. Both toe-in and toe-out will scrub speed so try to use as little as possible of either.

Front toe-in can be changed by adjusting the steering tie-rod turnbuckles. We recommend a starting setting of 0° of front toe-in.

Your team truck comes with 3° toe-in rear suspension mounts and 0° toe-in rear hub carriers. You replace these mounts and hub carriers to change the rear toe-in. Maximum toe-in recommended for the rear of the truck is 4.5° per side.

Toe-in and toe-out summary:

TOE-IN AND TOE-OUT:

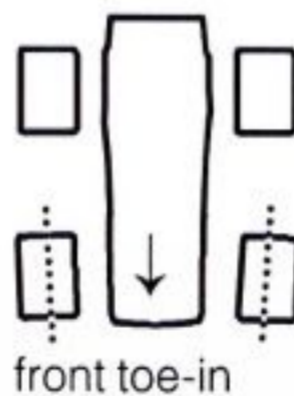

front toe-in

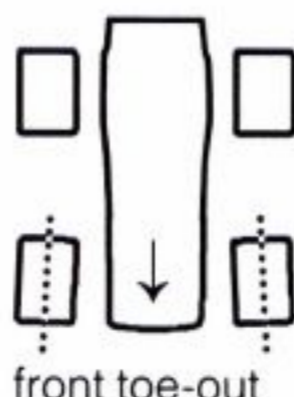

front toe-out

ADJUSTMENT:

Rear toe-in: change rear suspension mounts and/or rear hub carriers.

Front toe-in/toe-out: adjust steering tie-rod turnbuckles.

EFFECT:

Rear toe-in, increased: reduces speed; less steering, more rear traction.

Rear toe-in, decreased: increases speed; more steering, less traction.

Front toe-in: improves stability during acceleration; less turn-in steering.

Front toe-out: causes instability during acceleration and through bumps; more turn-in steering.

RECOMMENDED: 0° front toe-in.

Fig. 304

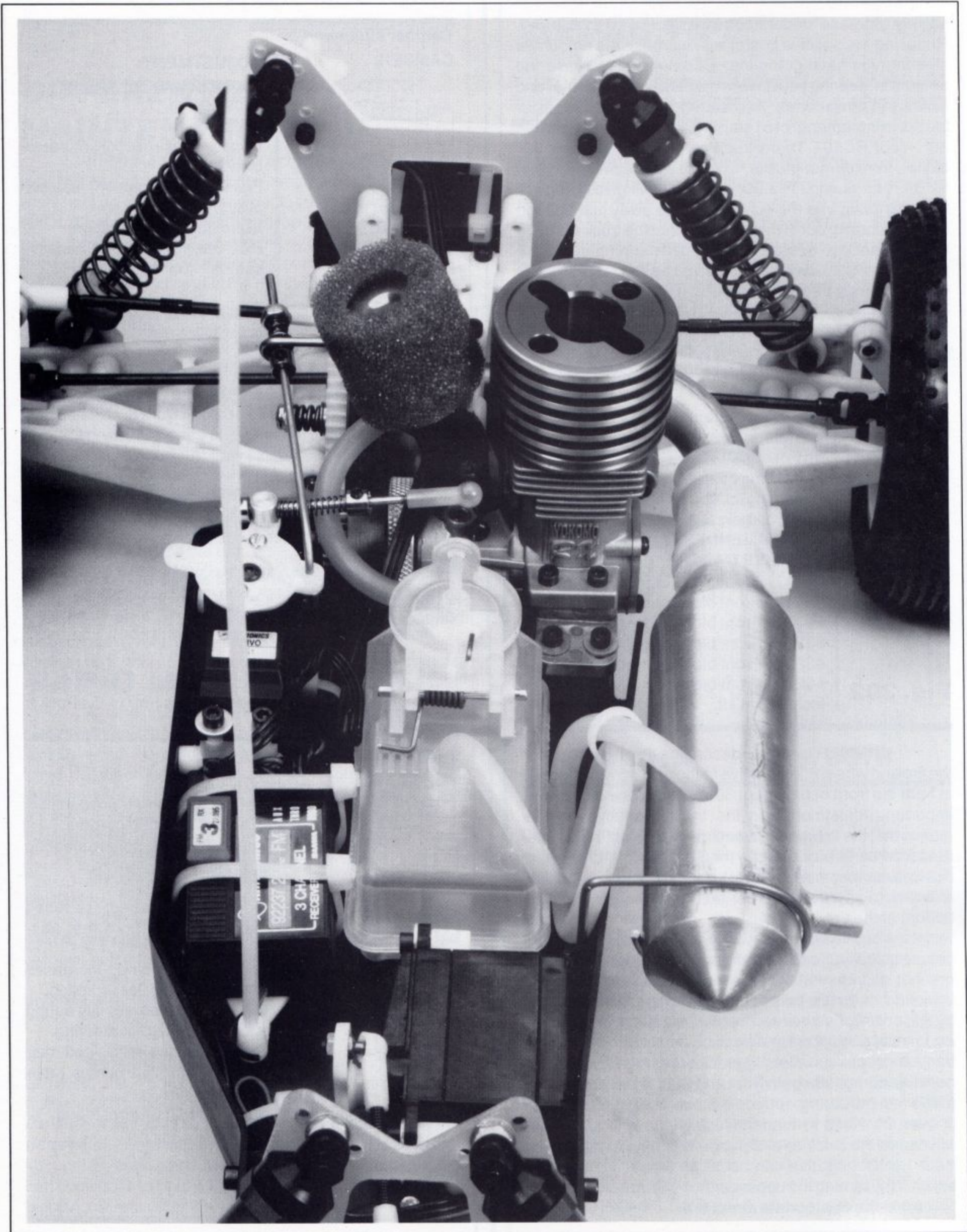

Fig. 305

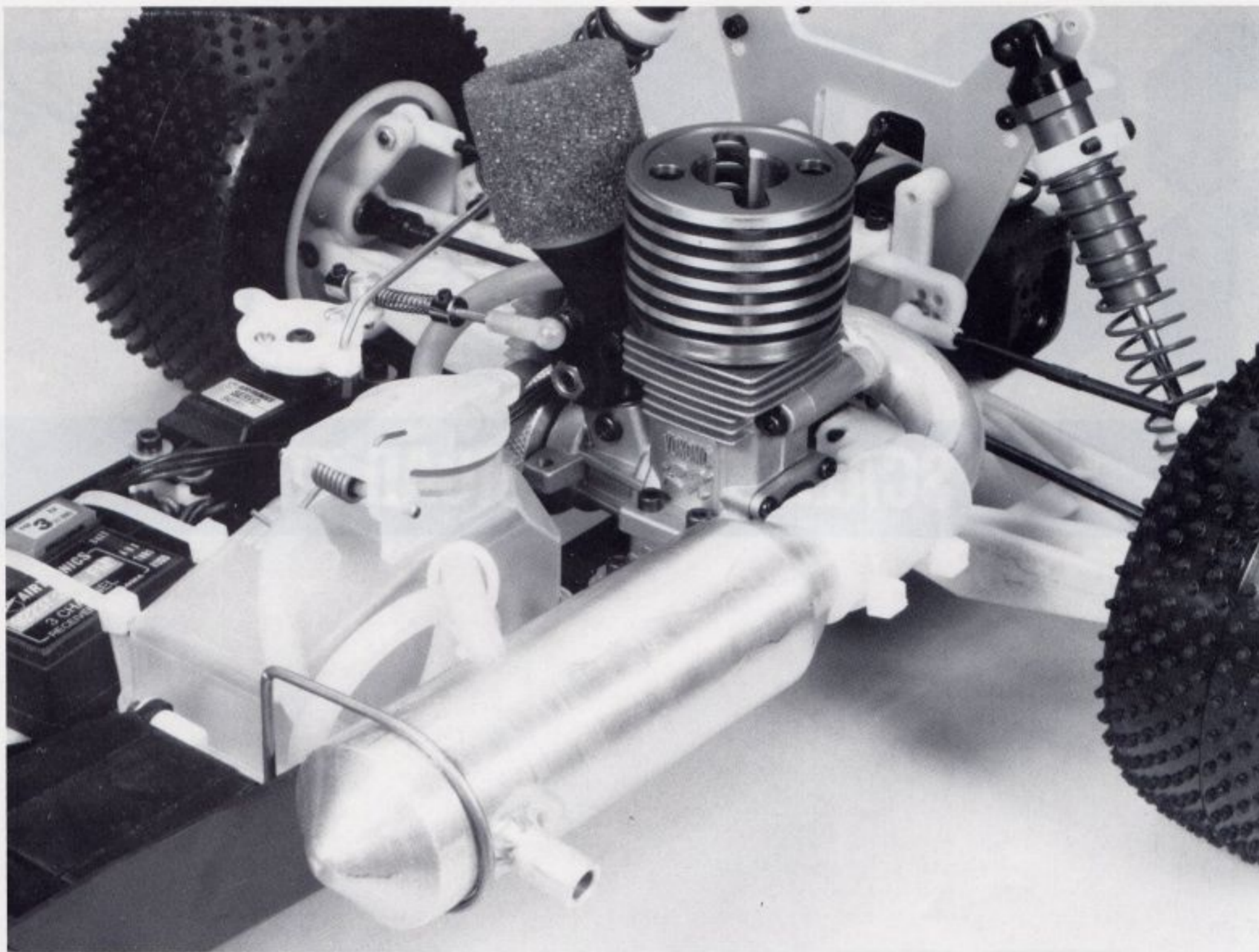

Fig. 306

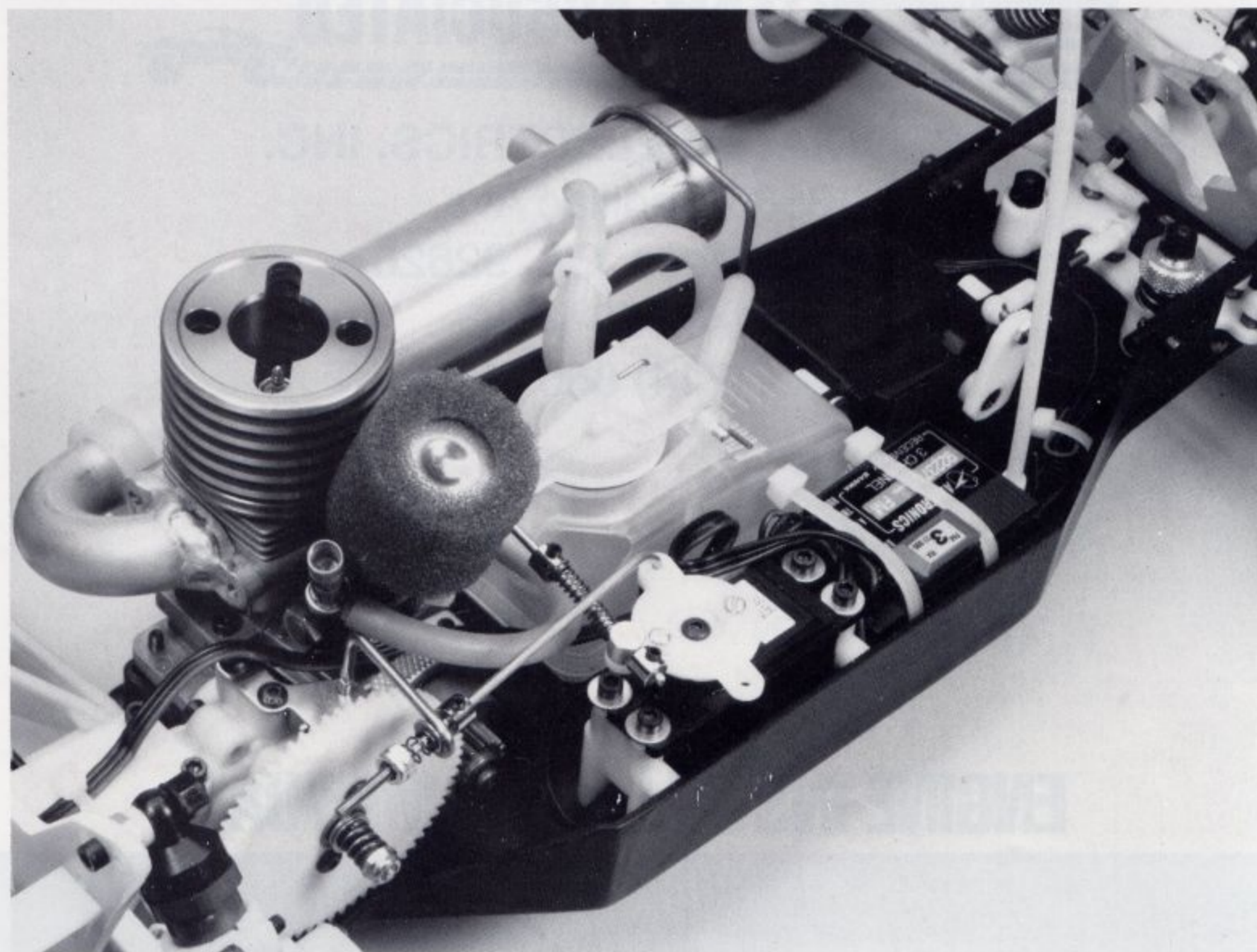

Fig. 307

RC10



1/10 SCALE GAS OFF ROAD TRUCK

20 TEAM ASSOCIATED 

ASSOCIATED ELECTRICS, INC.

3585 Cadillac Ave.

Costa Mesa, CA 92626

(714) 850-9342

FAX (714) 850-1744

ENGINE INSTALLATION MANUAL