

RADIO CONTROLLED ELECTRIC POWERED OFF-ROAD RECREATIONAL VEHICLE

# CAR CRUSHER DOUBLE DARE™ 4WDS

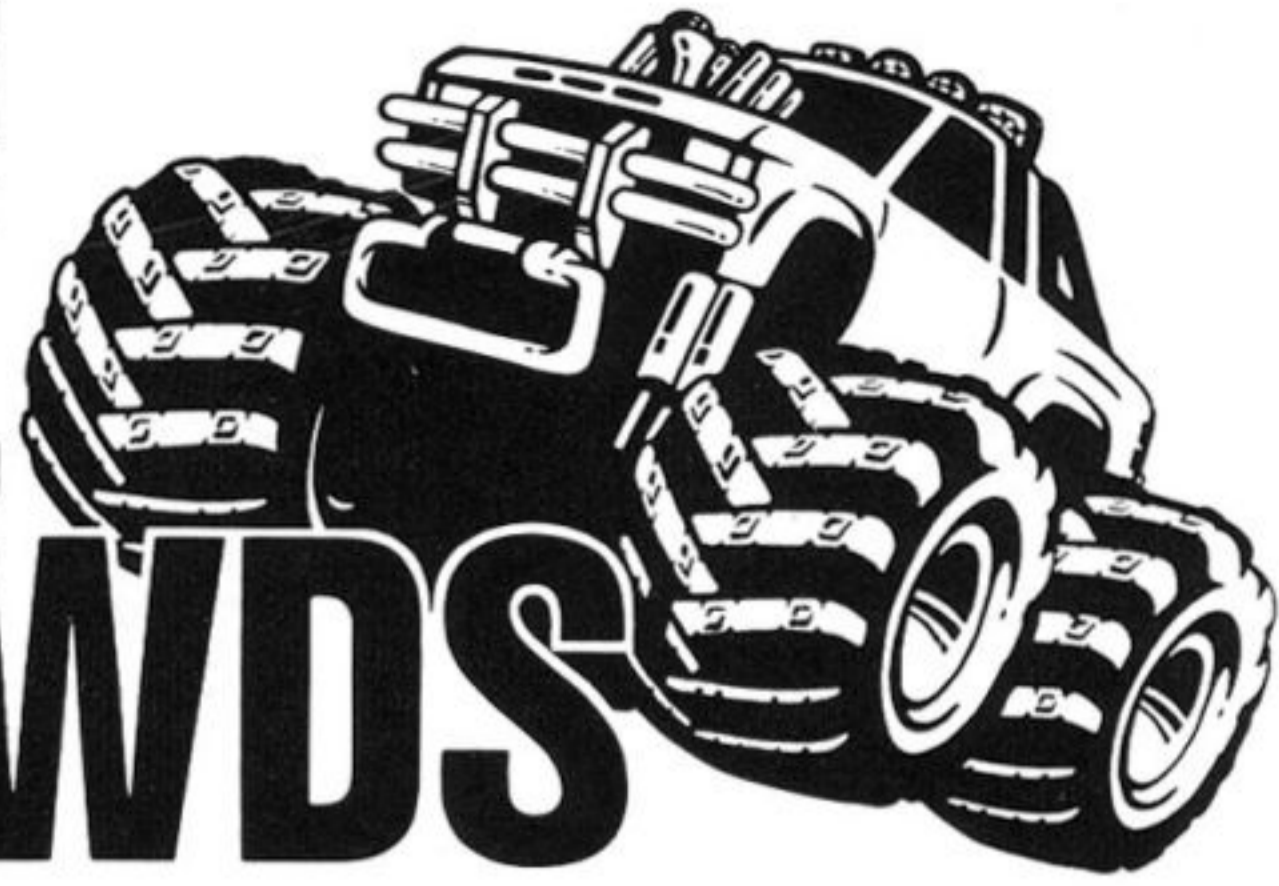

- DUAL MOTORS! REALISTIC CAR CRUSHING ACTION WITH TWICE THE POWER!
  - 4-WHEEL STEERING! TIGHT-TURNING MANEUVERABILITY!
- FULLY-INDEPENDENT LONG-TRAVEL DOUBLE WISHBONE SUSPENSION WITH DUAL SHOCK ABSORBERS ON EACH WHEEL!
- HIGH-QUALITY HEAVY DUTY "ROTARY" SPEED CONTROLLER WITH SILVER CONTACTS (INCLUDED).
  - TWO-POWERFUL LeMANS "STOCK 05" MOTORS (INCLUDED).
- GIANT SIZE TIRES FOR EASY ROLLING. STRONG, LIGHT WEIGHT, CHROME-PLATED NYLON WHEELS.
- SCALE NISSAN PICKUP TRUCK BODY. MANY DETAILED PARTS ADD COMPLETE REALISM.
  - STRONG, LIGHT ABS TUB CHASSIS.
- SPEED CONTROLLER AND RADIO GEAR MOUNT INSIDE ENCLOSED CHASSIS FOR PROTECTION.
  - BATTERY 7.2V-1200/1700 mAh NiCd (NOT INCLUDED)
  - RADIO CONTROL SYSTEM/2-CHANNEL (NOT INCLUDED)

1:10 SCALE

RADIO: 2-CHANNEL  
BATTERY: 7.2V, 1200MA NICD  
(NOT INCLUDED)



**KYOSHO**  
THE FINEST RADIO CONTROL MODELS

ENTIRE CONTENTS © COPYRIGHT 1988 **HOBBICO**™ INC. KIT NO. 3106

SPECIFICATIONS ARE SUBJECT TO CHANGE WITHOUT NOTICE.

## THINGS YOU WILL NEED BESIDES THIS KIT

### 2 CHANNEL RADIO SYSTEM

A two channel, two servo radio control system is required for running the Double Dare. The various components are pictured below.

#### TRANSMITTER



"Wheel Type"

#### SERVOS

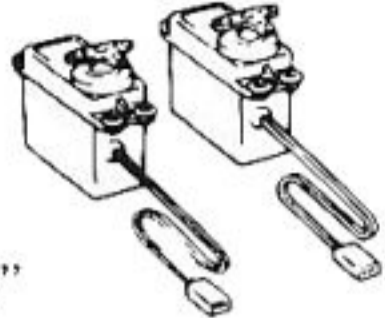

#### HOLDER



#### RECEIVER

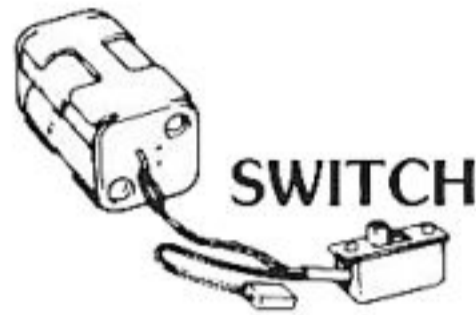

#### SWITCH

**Note:** Use only radio frequencies specifically allowed to operate "surface" models such as R/C cars and boats. In the United States those frequencies fall within the "75 MHz" or "27MHz" bands. Use of any other frequencies is both illegal and dangerous.

### OPTIONAL MOTORS

The Double Dare comes with powerful LeMans "Stock 05" motors. If you wish to upgrade the Double Dare with more power and more speed use a 480T or 480G or even the 240S motor. All of these motors will increase the speed and torque but will also decrease the run time. Choose the motor that will best suit your needs. Ask your local dealer for more information.



LeMans 480T



LeMans 480G



Lemans 240S

### CHECK YOUR RADIO SYSTEM

Follow the instructions that came with your radio system to check out its operation.

You will also need to supply your radio with the proper number of batteries (usually 7 or 8 in the transmitter). The receiver is powered by the 7.2V battery.

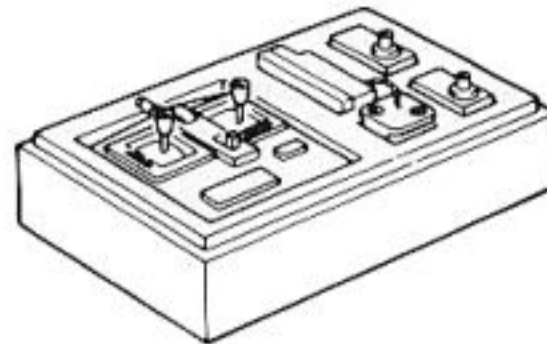
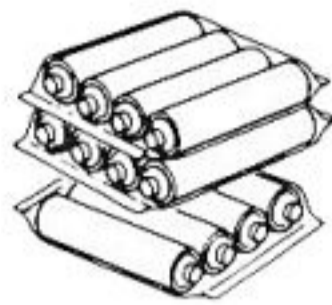

### BATTERY PACK

A 6-cell flat configuration 7.2V battery similar to the shape of the batteries shown here is required. The Kyosho #2310 and the Kyosho 2306 are very good choices.



No. 2306 7.2V Power Battery



No. 2310 7.2V Sprint Battery

### CHARGER

You'll need a charger to charge your battery. Kyosho offers a few different types designed for 6-cell fast charging, here are two very popular models.

#### CHARGERS

Model	Name	Time	Rate %	Features
No. 2326	Power Quick Charger	15-25 Min.	70%	7.2V 6-Cell Charging w/Built-in Timer
No. 1849	Multi Charger II	20 Min.	70%	Charges 4-7 Cell with variable current adjustment

### POWER QUICK CHARGERS



#2326



#1849

### REQUIRED TOOLS

These tools ARE included in the Double Dare kit.

#### 1.5mm Allen Wrench

#### 2mm Allen Wrench



#### Grease



These ARE NOT included with the Double Dare.

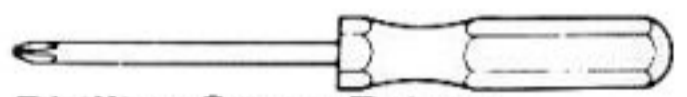

#### Phillips Screw Driver



#### Standard Screw Driver

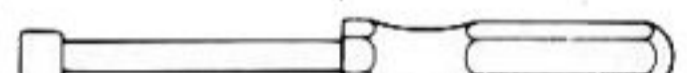

#### 5.5mm and 7mm Nut Driver

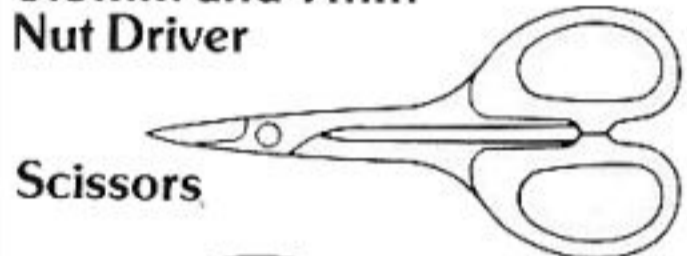

#### Scissors

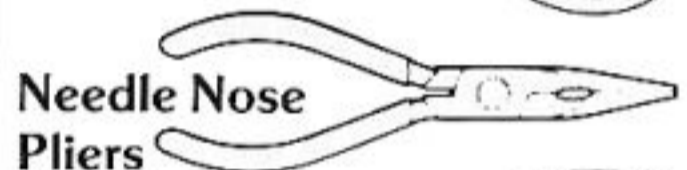

#### Needle Nose Pliers



#### Hobby Knife



#### Paint

#### Masking Tape

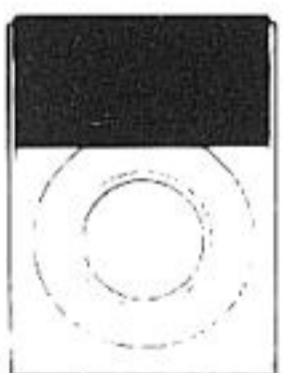

#### Paint Brush

### IMPORTANT! BEFORE YOU BEGIN

This is a sophisticated model with a large number of moving parts. Before you begin assembly, take a look through the box and these instructions carefully to decide whether or not you are ready for this challenge! If you do not feel that this type of model is for you, it may be returned to the dealer as long as it is NEW and UNUSED. UNDER NO CIRCUMSTANCES CAN YOUR DEALER ACCEPT A KIT FOR RETURN IF ASSEMBLY HAS ALREADY BEGUN! If this is not what you bargained for, then go no further and return this kit to the dealer immediately. BUT, if a little maintenance doesn't bother you and the thrill of high performance driving is for you, then don't hesitate another minute! Read through this entire manual thoroughly to familiarize yourself with the parts and methods of construction used before actually starting to build.

### WARRANTY INFORMATION

Your model is under warranty for a period of 90 days. If the model you purchased is defective when you receive it, Kyosho's authorized U.S. repair facility will repair or replace at their option the model without charge. If you have any problems, enclose proof of purchase with the items and send it to: Hobby Services, 1610 Interstate Drive, Champaign, IL 61821. Phone (217)398-0007.

### METRIC NUTS AND BOLTS

All nuts and bolts used throughout this kit are metric size. Therefore, some of the notations may not be familiar to you. An M3 nut is a 3 millimeter (3mm) nut. An M3x15 screw is 15mm long and 3mm in diameter. Some round parts may be labeled as a "4mm Washer" (this would be a washer with a 4mm inside diameter) or a "3mm Bushing" (a bushing with a 3mm inside diameter).

At various points throughout the manual these parts are labeled and pictured in their actual size on the left hand side of the page. For your reference, 1 millimeter equals approximately .039 inches.

#### M3x15 SCREW

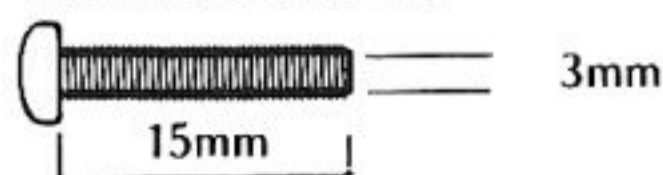

#### 4mm WASHER

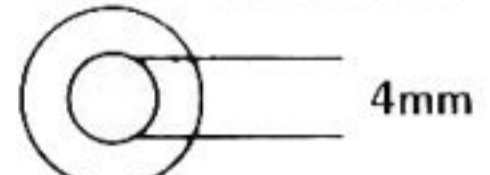

#### SELF TAPPING (S/T)

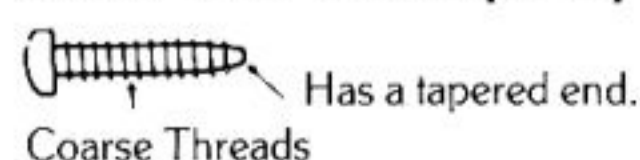

Has a tapered end.  
Coarse Threads

#### SCREW

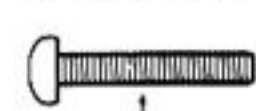

Fine Threads

If it is an ordinary screw it will be marked "screw".



©ENTIRE CONTENTS  
COPYRIGHT 1988 HOBBICO, INC.

# 1 GEAR BOX ASSEMBLY (A)

NOTE: All "D" parts can be found on plastic parts tree.

M8 WASHER	2
IDLE GEAR SHAFTS	2
DIFFERENTIAL JOINT SHAFT	2
IDLE GEAR SHAFT PIN (SILVER)	2
M4 BUSHING	4

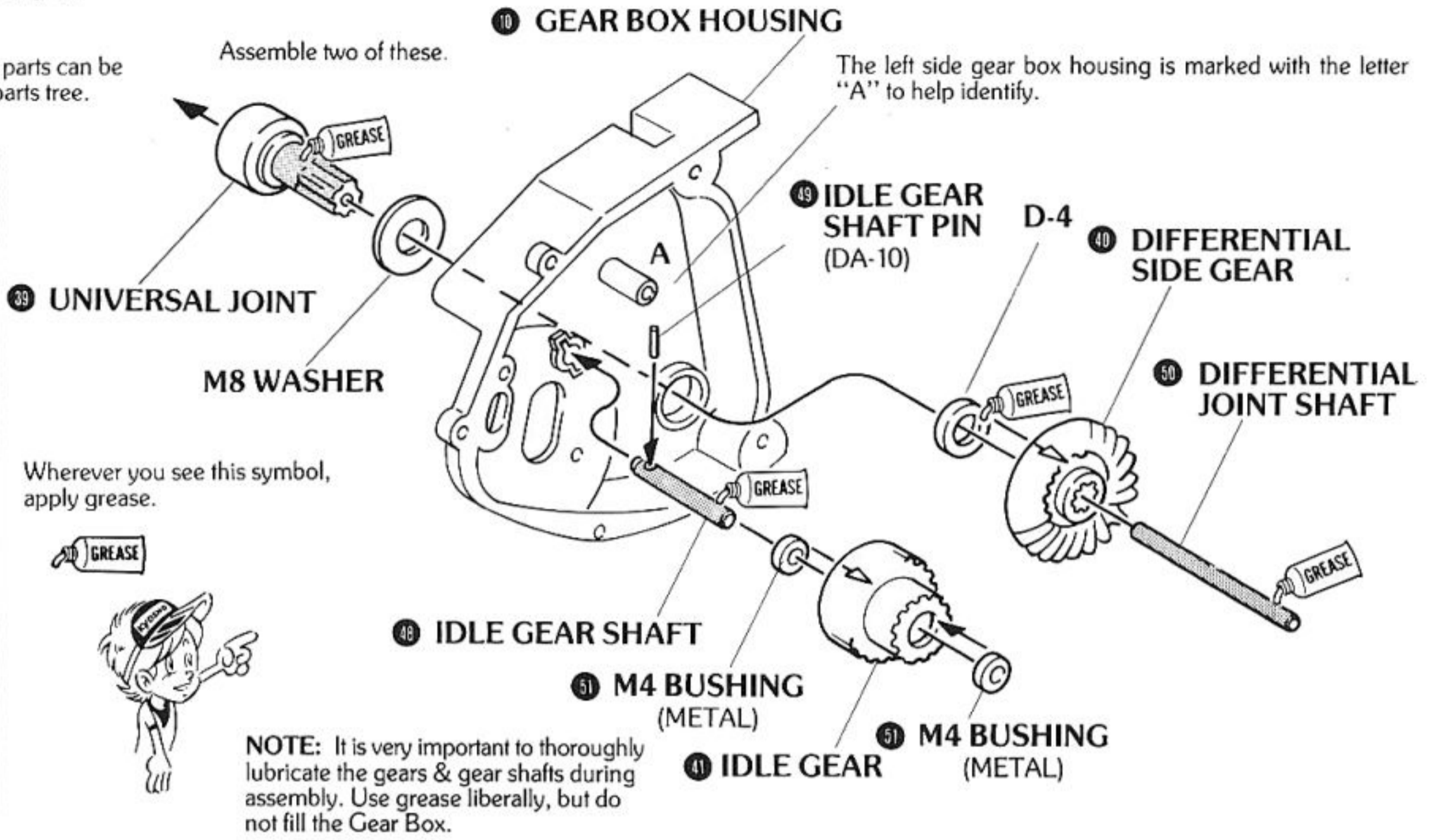

# 2 GEAR BOX ASSEMBLY Assemble two of these.

M3x12 S/T SCREW

BUILD 2 GEAR BOXES

M8 WASHERS	2
M3 x 12 S/T SCREWS	8
COUNTER GEAR SHAFT	2

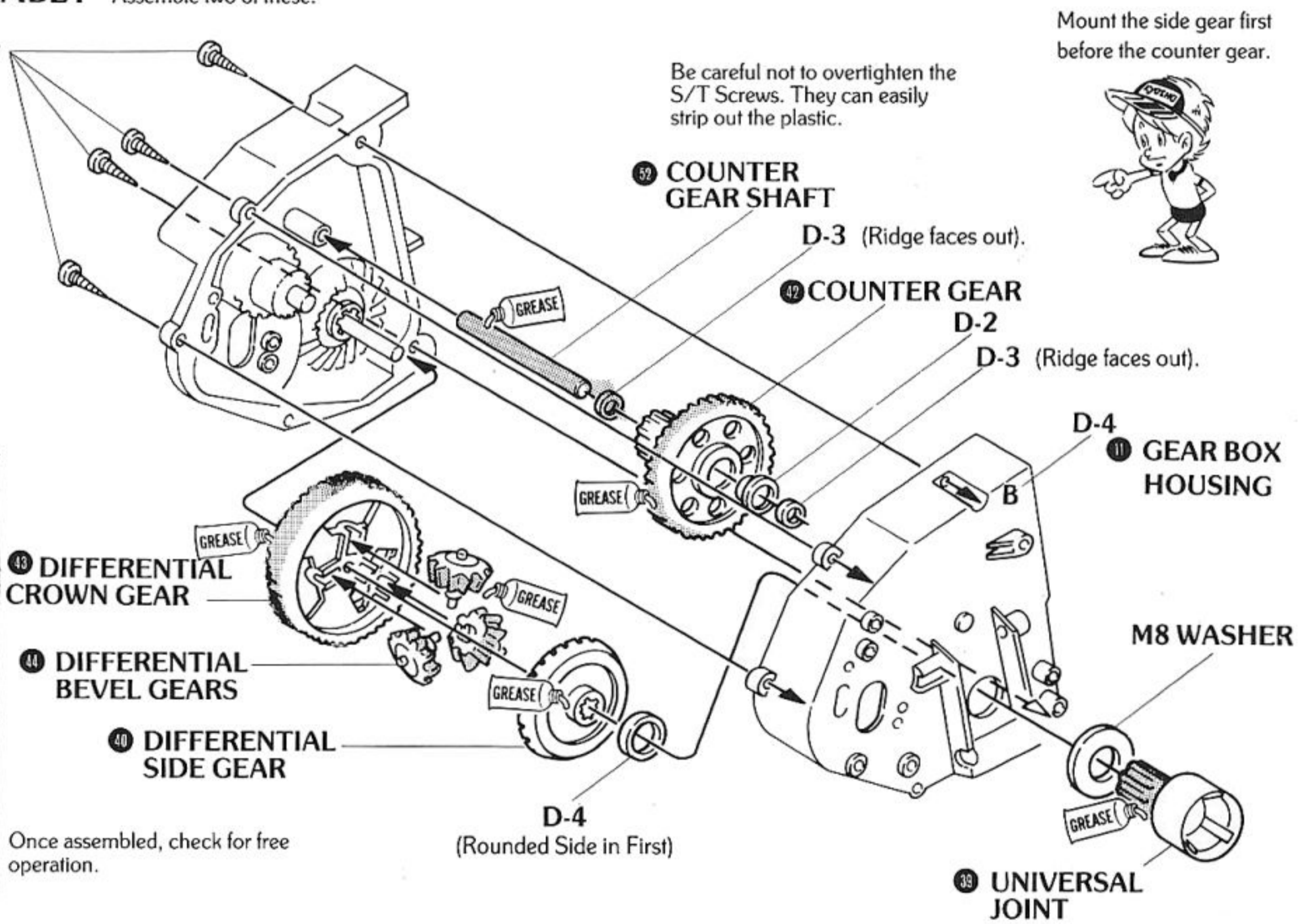

# 3 SUSPENSION ARM ASSEMBLY

M2 x 6 S/T SCREWS	16
M3 x 28 SCREWS	4
8MM PIVOT BALL (GOLD)	8
8MM BALL SEATS	8
5MM BUSHING (WHITE PLASTIC)	8
KNUCKLE STOPPER (Gold)	4

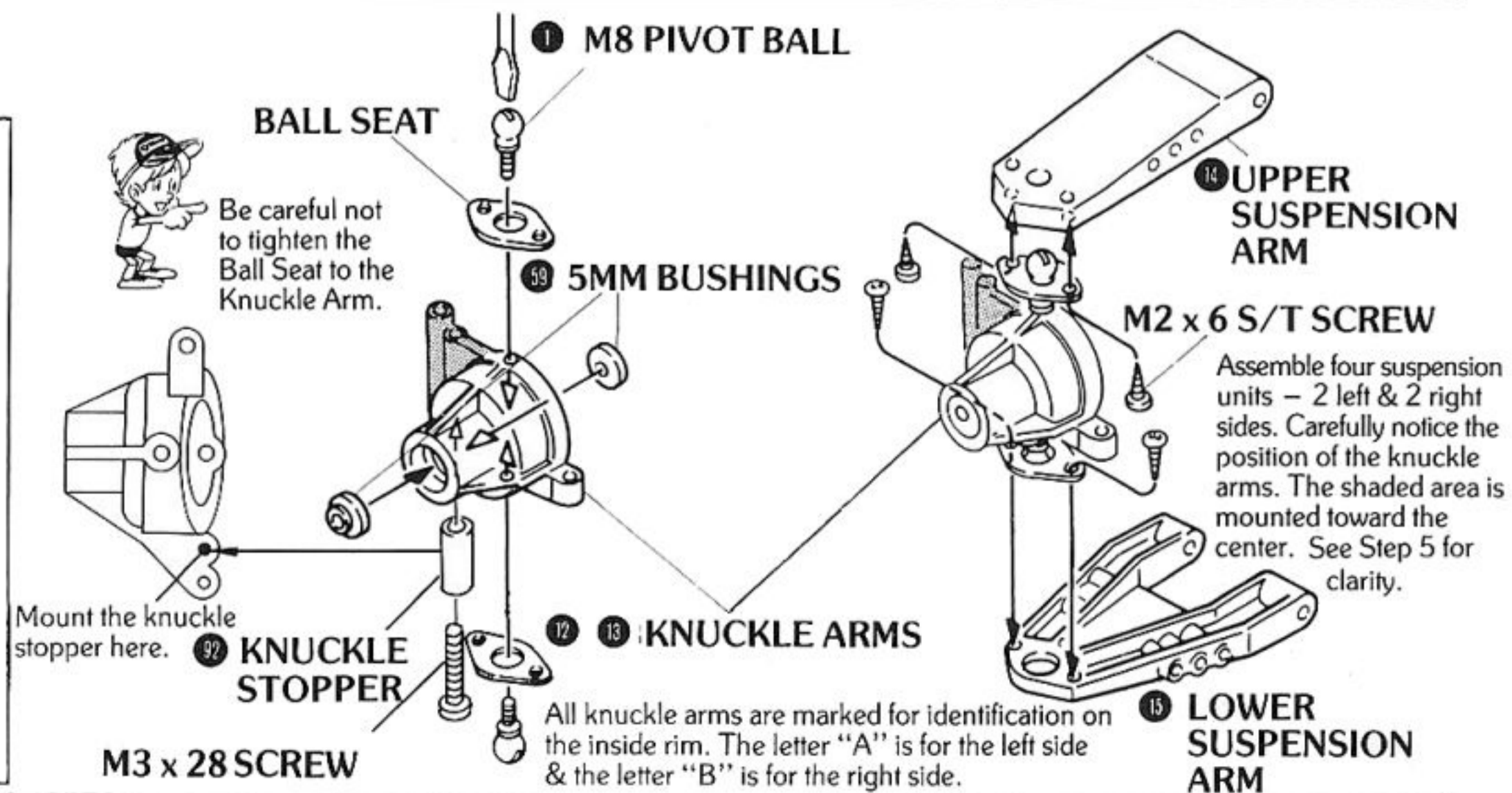

# 4 CHASSIS CONSTRUCTION

NOTE: Mount the other gear box in the same fashion on the opposite side of the chassis.

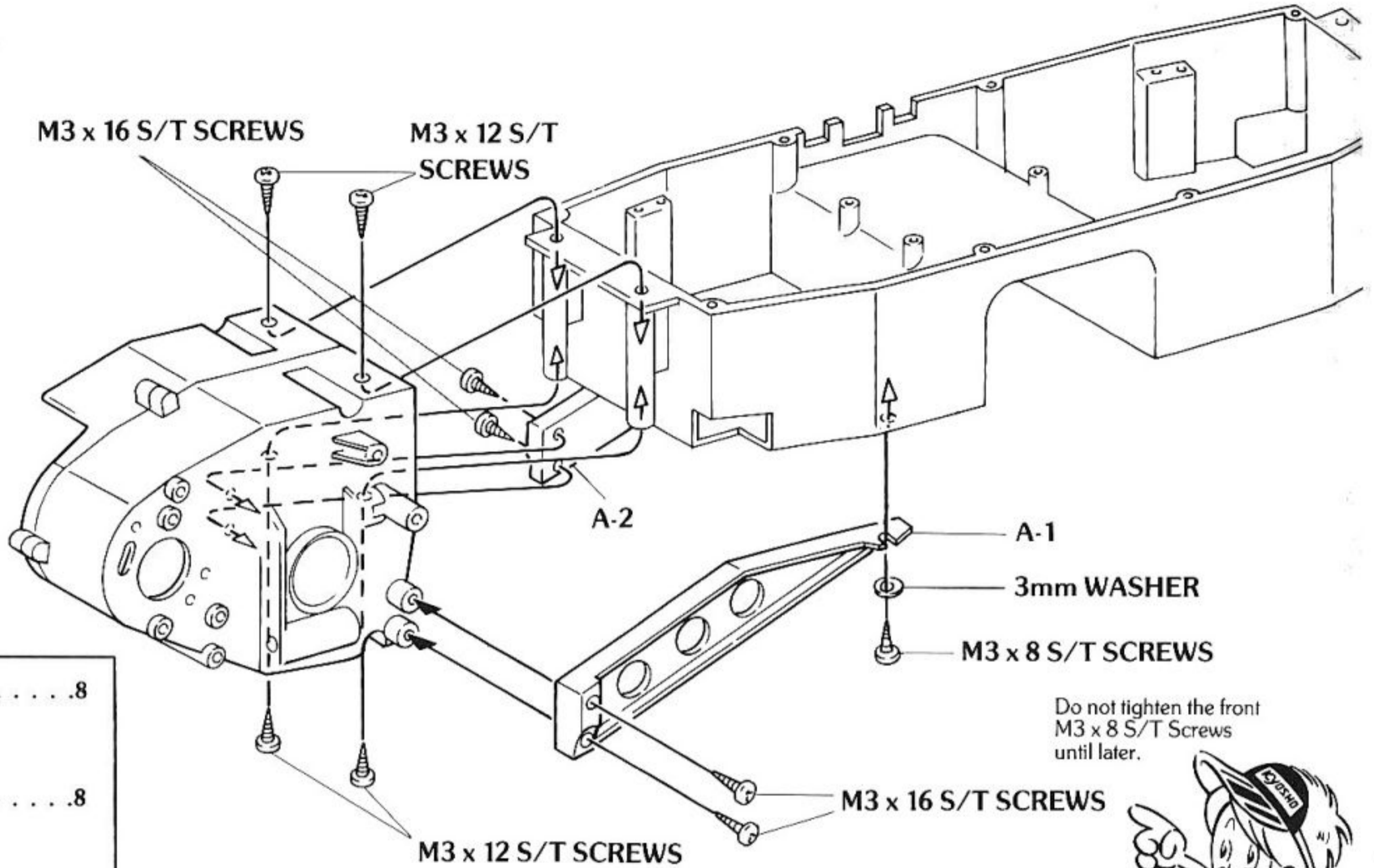

- M3 x 16 ST SCREW . . . . .8
- M3 x 12 ST SCREW . . . . .8
- M3 x 8 ST SCREW . . . . .4
- 3mm WASHER . . . . .4

Do not tighten the front M3 x 8 S/T Screws until later.



# 5 SUSPENSION ARM INSTALLATION

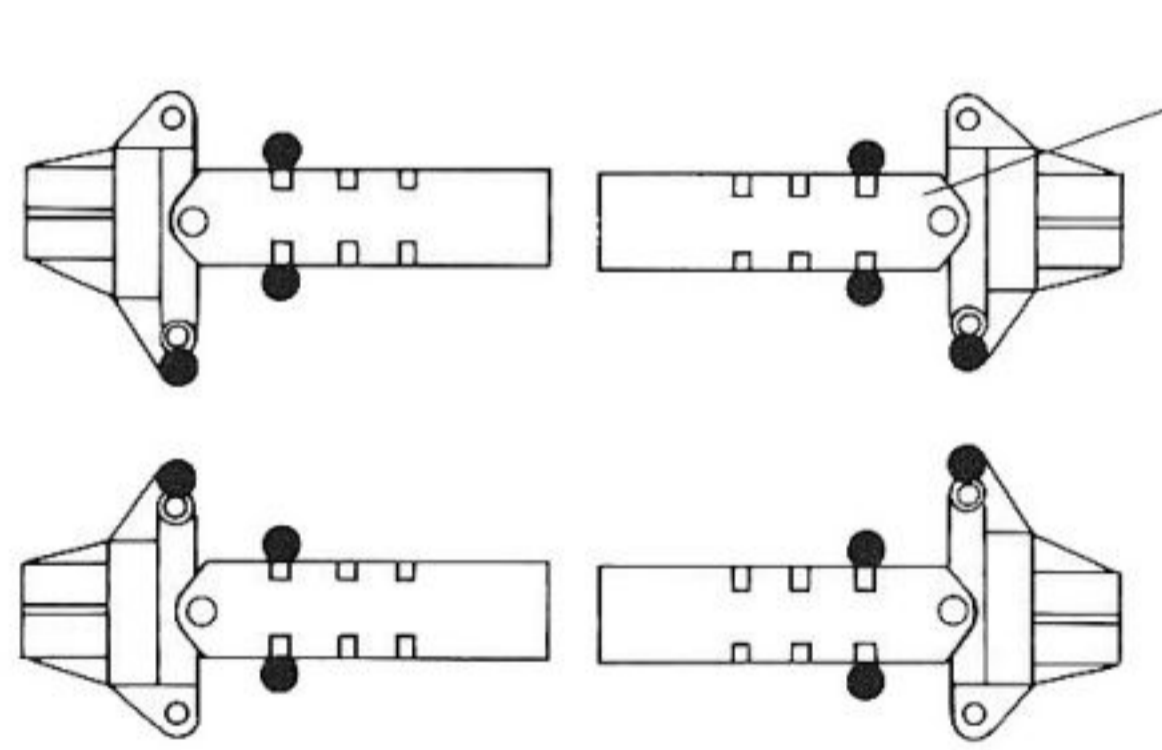

Black dots indicate pivot ball locations.

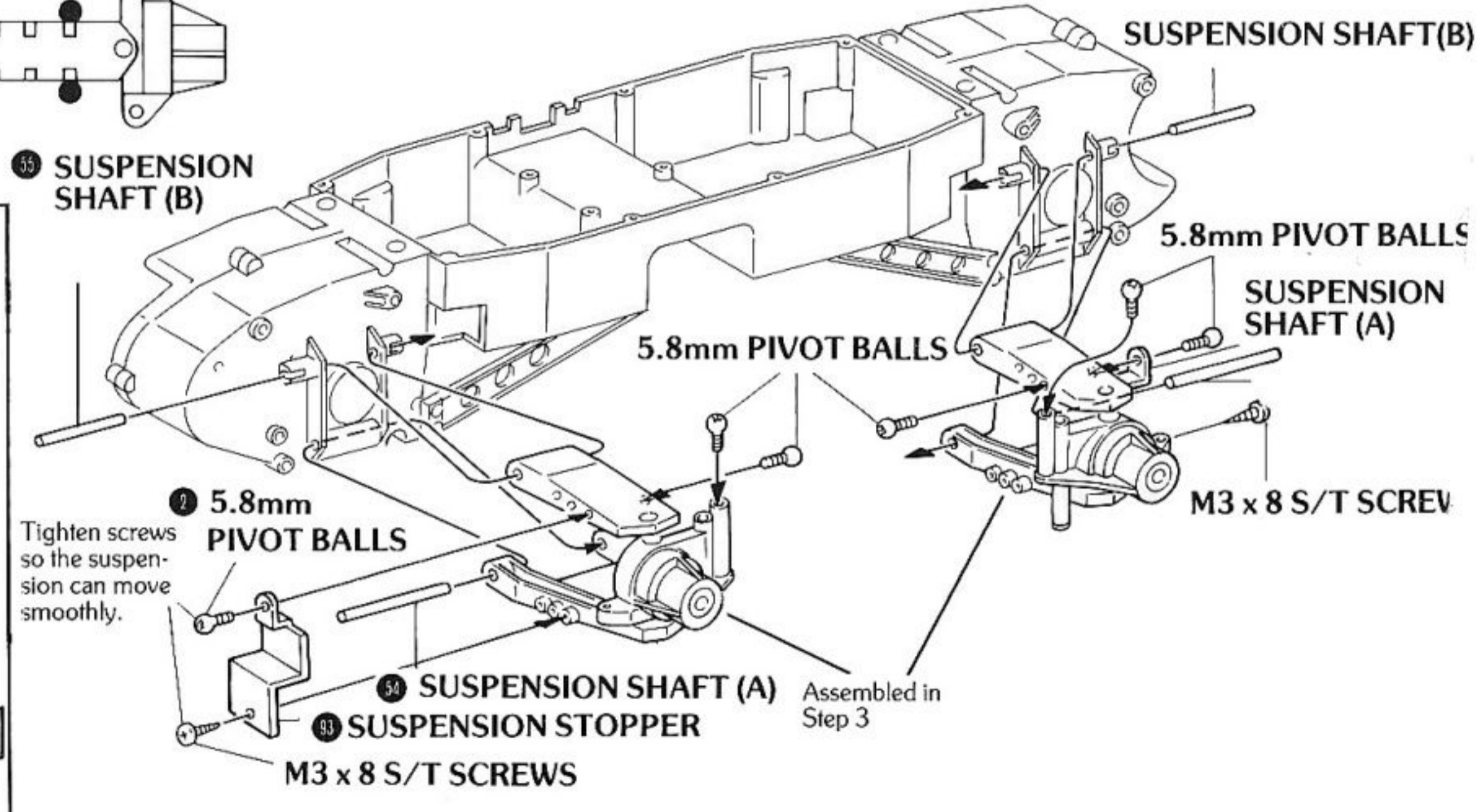

55 SUSPENSION SHAFT (B)

SUSPENSION SHAFT (B)

5.8mm PIVOT BALLS

SUSPENSION SHAFT (A)

5.8mm PIVOT BALLS

M3 x 8 S/T SCREW

2 5.8mm PIVOT BALLS

Tighten screws so the suspension can move smoothly.

54 SUSPENSION SHAFT (A)

93 SUSPENSION STOPPER

M3 x 8 S/T SCREWS

Assembled in Step 3

- M3 x 8 ST SCREW . . . . .4
- 93 SUSPENSION STOPPER .4
- 2 5.8MM PIVOT BALL . .12 (SILVER)
- 54 SUSPENSION SHAFT (A) .4 (LONGER)
- 55 SUSPENSION SHAFT (B) .4 (SHORTER)

## 6 RADIO CONTROL UNIT

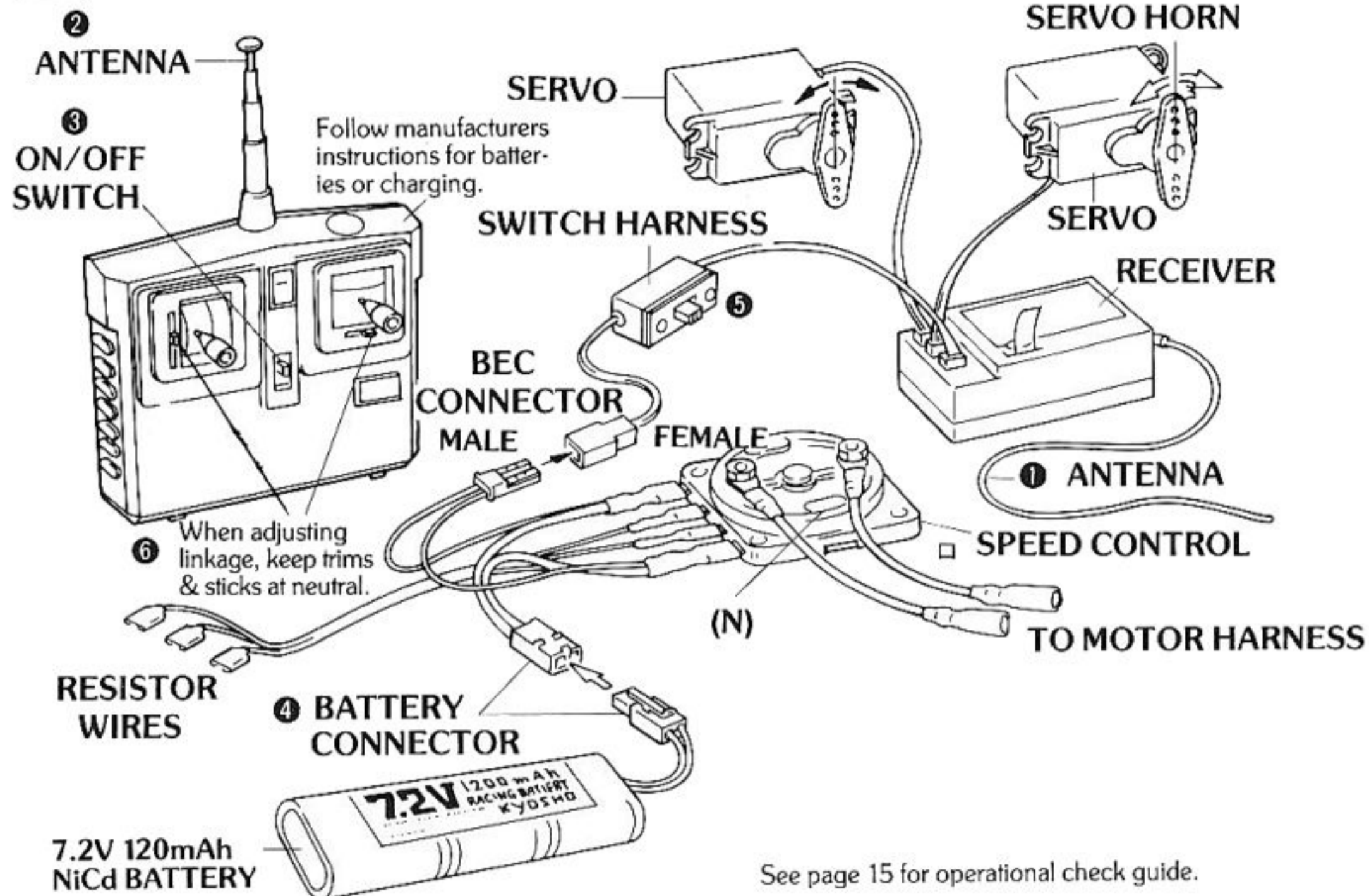

"STICK" TYPE

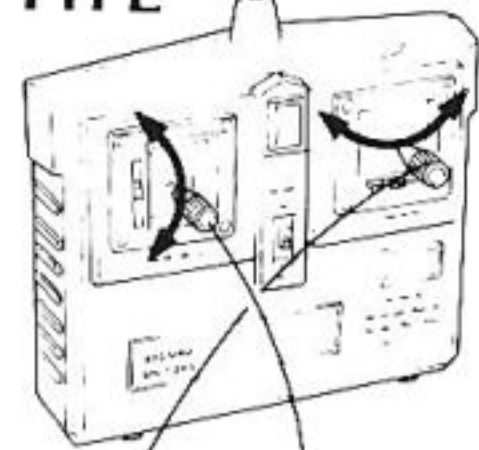

THROTTLE CONTROL

STEERING CONTROL



"WHEEL" TYPE

See page 15 for operational check guide.

## 7 SPEED CONTROL INSTALLATION

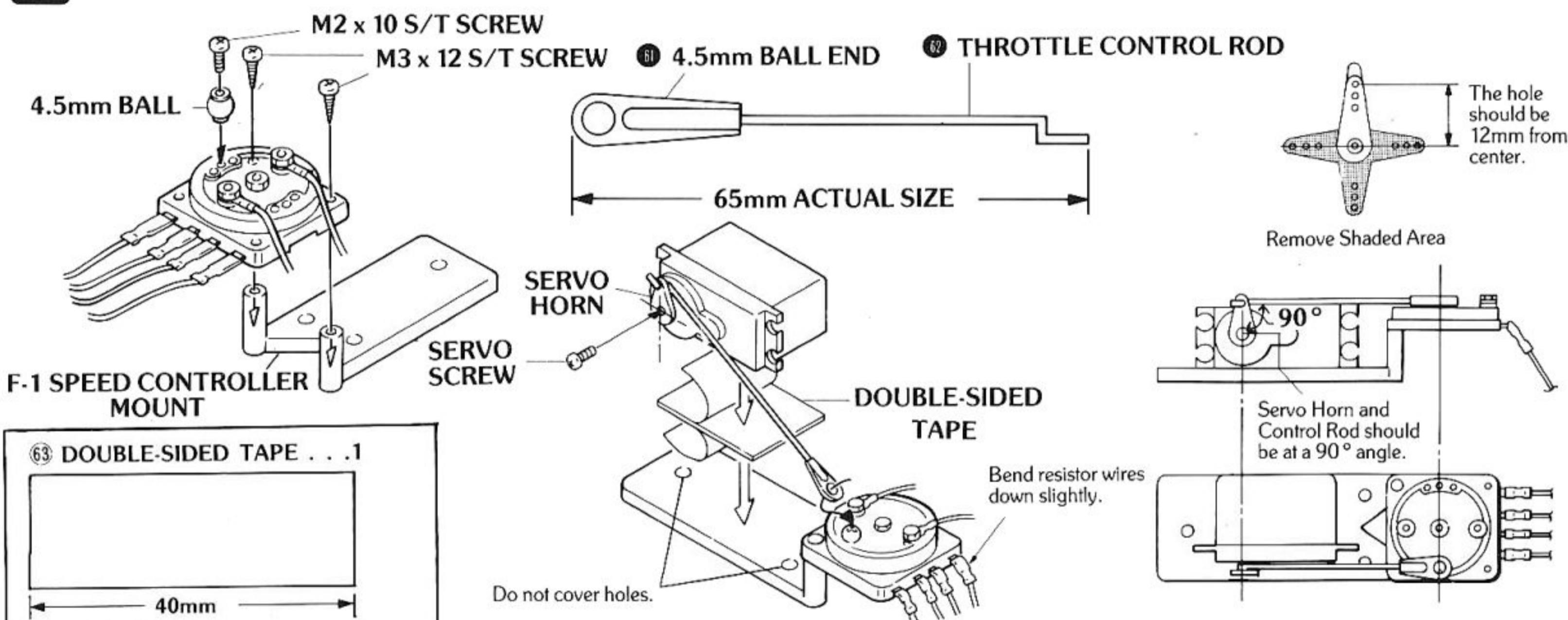

- 63 DOUBLE-SIDED TAPE . . . 1
- 40mm
- M3 x 12 ST SCREW . . . . . 2
- M2 x 10 SCREW . . . . . 1
- 60 4.5mm BALL . . . . . 1
- 61 4.5mm BALL END . . . . . 1
- 62 SPEED CONTROL ROD . . . 1

Certain high performance parts like the Kyosho Speed Control require routine maintenance to ensure continued reliability in operation. We suggest that you perform the following maintenance procedures after each day of racing for continued peak performance.

1. Remove center bolt 'A' to disassemble.
2. Inspect wire holding nuts 'B' and 'C' for tightness. Tighten if loose.
3. Check contact 'D' for free vertical movement.
  - A. If binding exists, remove wire holding nuts 'B' and 'C' to disassemble contact mechanism for cleaning.
4. Clean all dust and dirt from the contact pad areas 'E' and 'F'. A pencil eraser can also be used to burnish the contact pad areas.
5. Reassemble speed controller.
6. After assembly, rotate speed controller through its full movement cycle.
  - A. Make sure the control rod 'G' does not strike one of the wire nuts 'B' and 'C'. If this occurs, the control rod must be repositioned.
  - B. Check that the supply wire terminals 'H' and 'J' turn freely in the rotor when it is moved through its full duration.

The Kyosho Speed Control comes with an extended warranty. If it should require repair or fail to operate, please contact Kyosho's authorized U.S. repair facility for warranty repair or replacement:

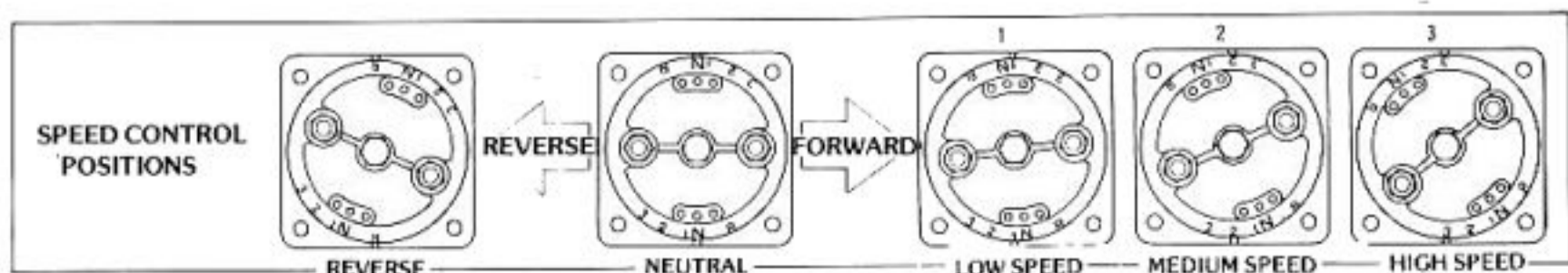
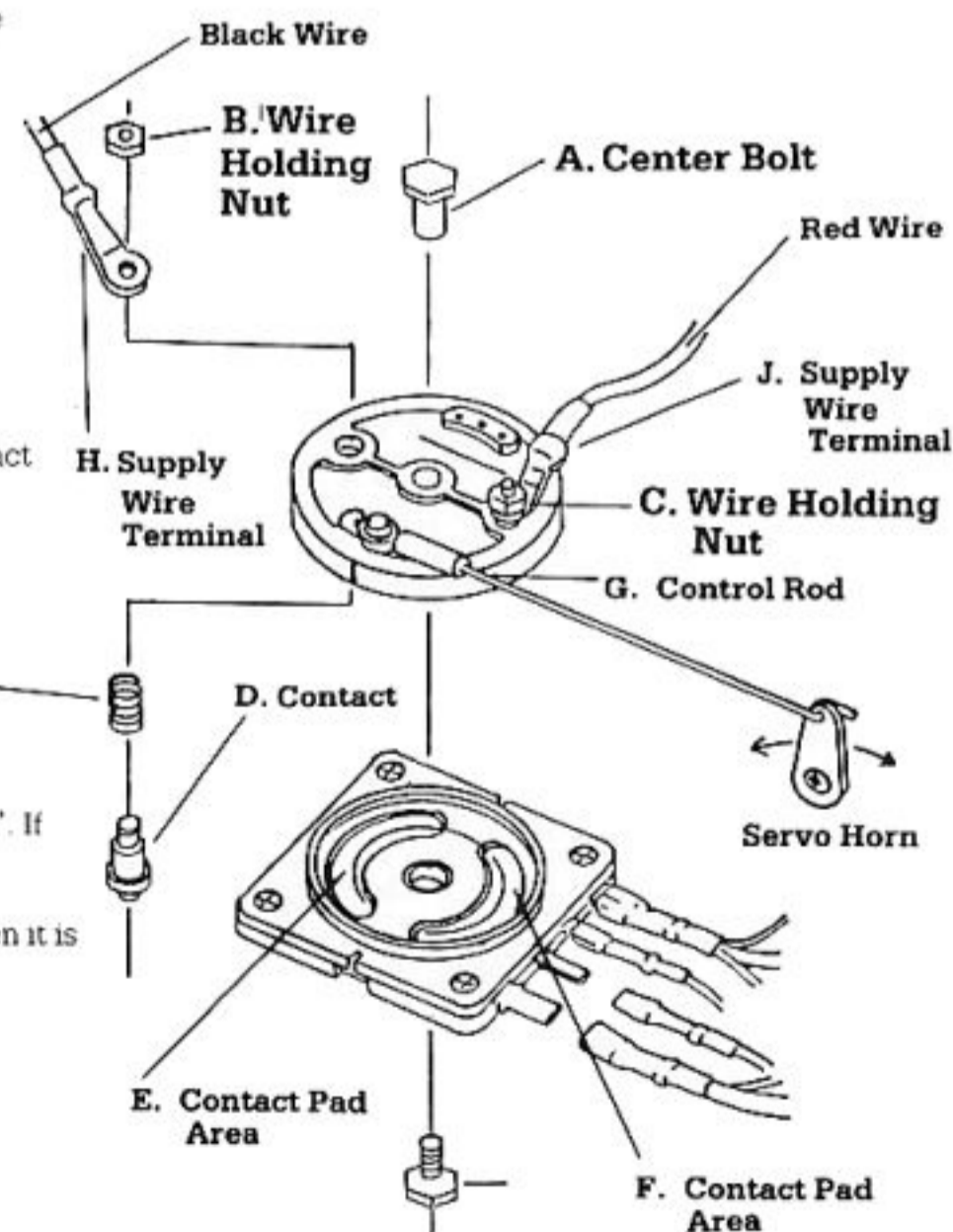

# 8 STEERING SERVO

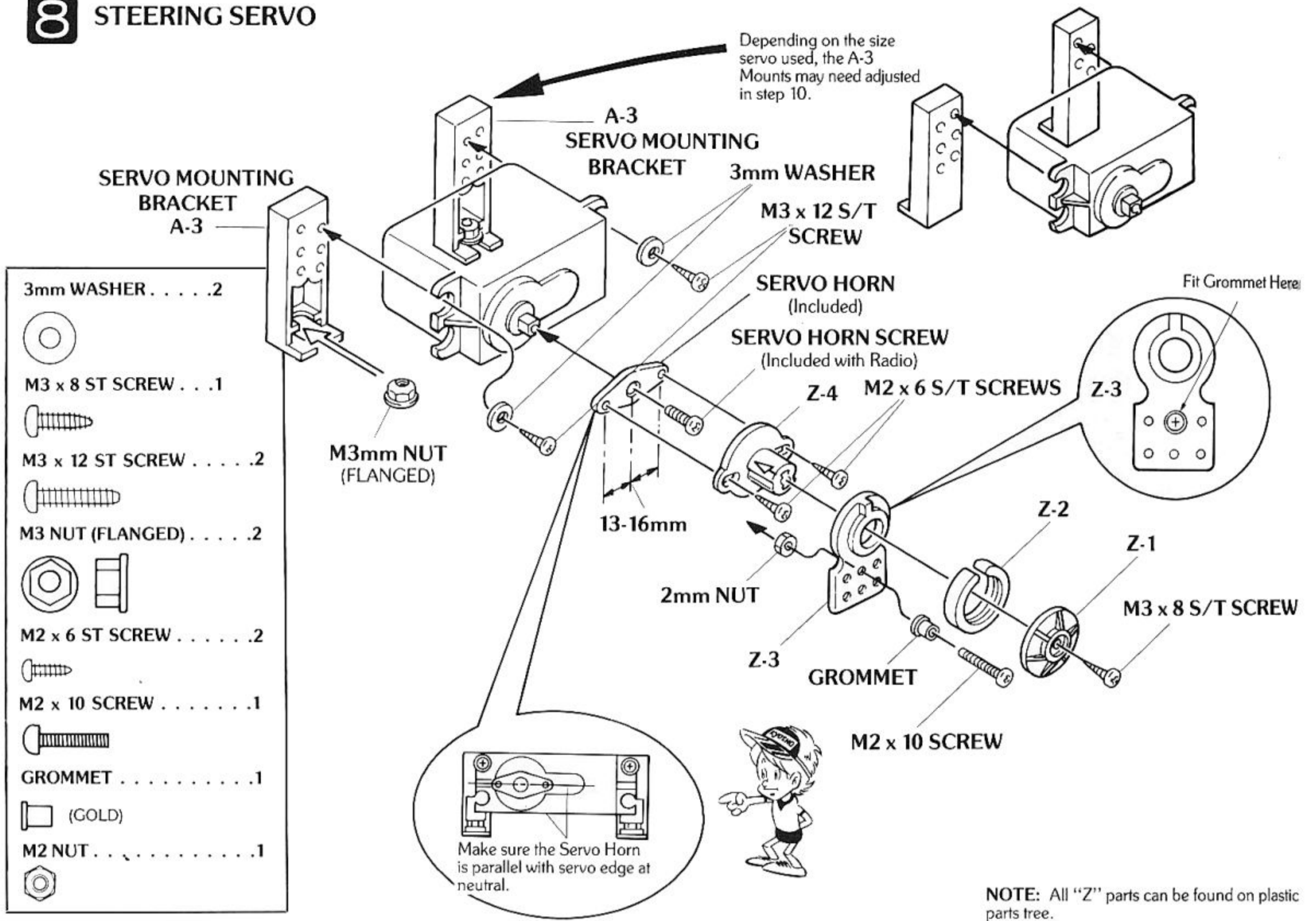

# 9 SERVO SLIDE RAIL

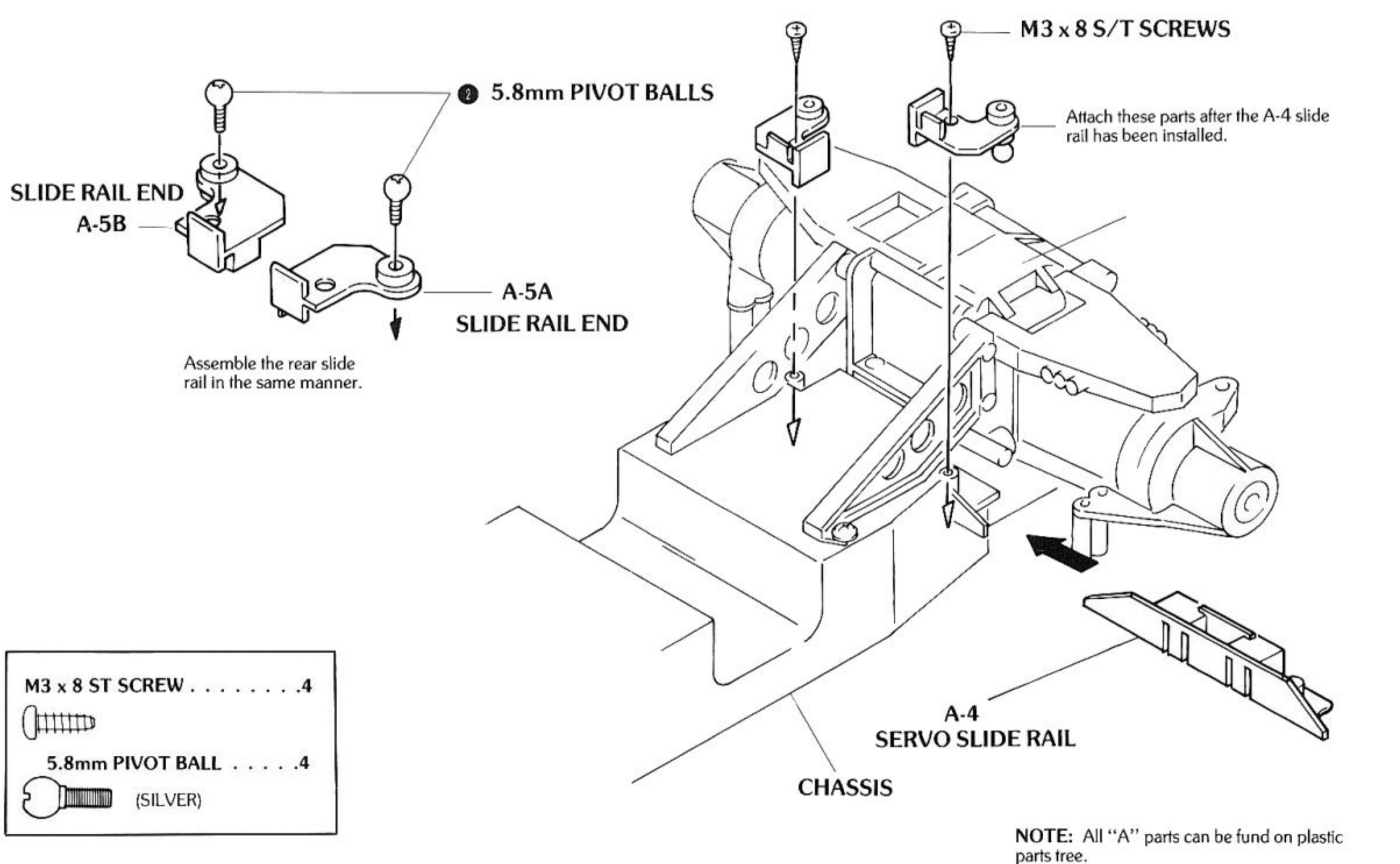

# 10 RADIO INSTALLATION

- M3 x 8 ST SCREW . . . . .3
  - M3 x 8mm SCREW . . . . .2
  - 3mm WASHER . . . . .2
  - GROMMET . . . . .1
  - DOUBLE-SIDED TAPE .1
- 40mm

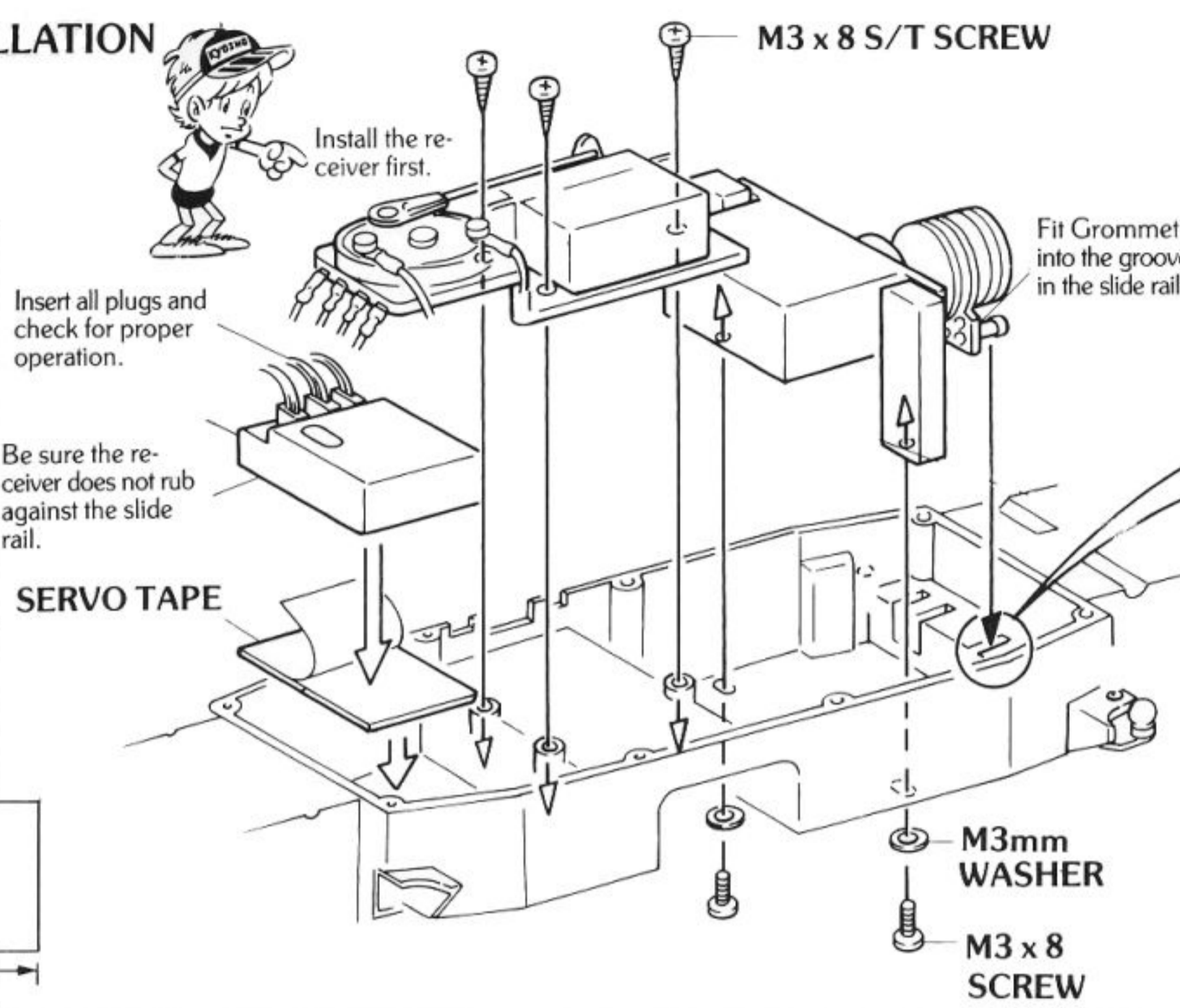

Adjust the servo mounting brackets A-3 so there is 2mm clearance here.

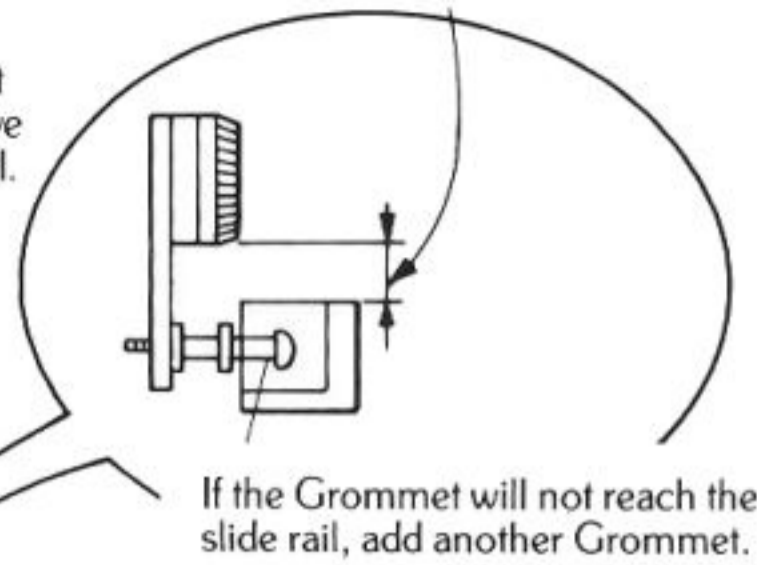

Note: After the servo is mounted, tighten the M3 x 8 S/T Screws from Step 4.

# 11 STEERING ROD INSTALLATION

- M3 x 12 ST SCREW . . . . .4
- M3 x 8 ST SCREW . . . . .2
- 3mm WASHER . . . . .2

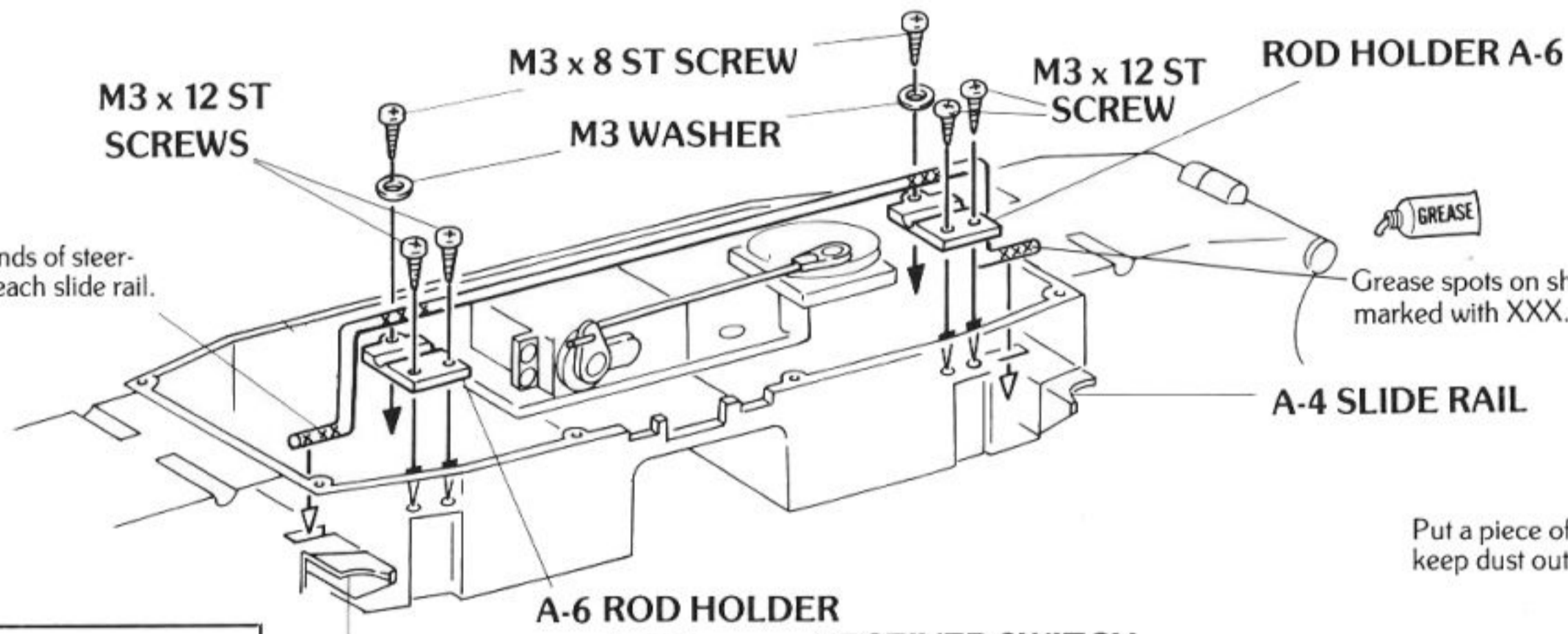

Put a piece of tape here to keep dust out of radio tray.

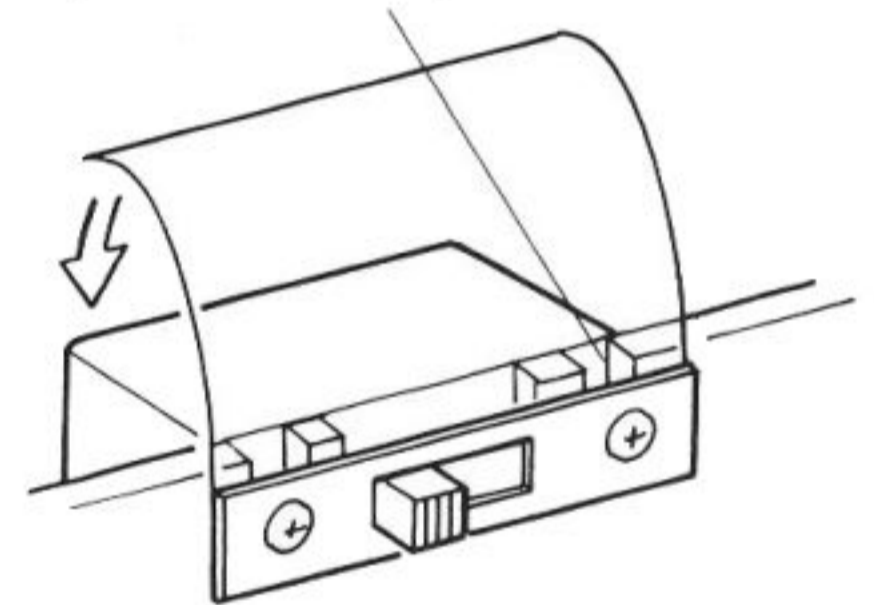

# 12 TIE ROD AND SUSPENSION ARM ASSEMBLY

- 5mm WASHER . . . . .4
- WHEEL SHAFT . . . . .4
- 5.8mm BALL END . . . . .8
- M3 ROD . . . . .4

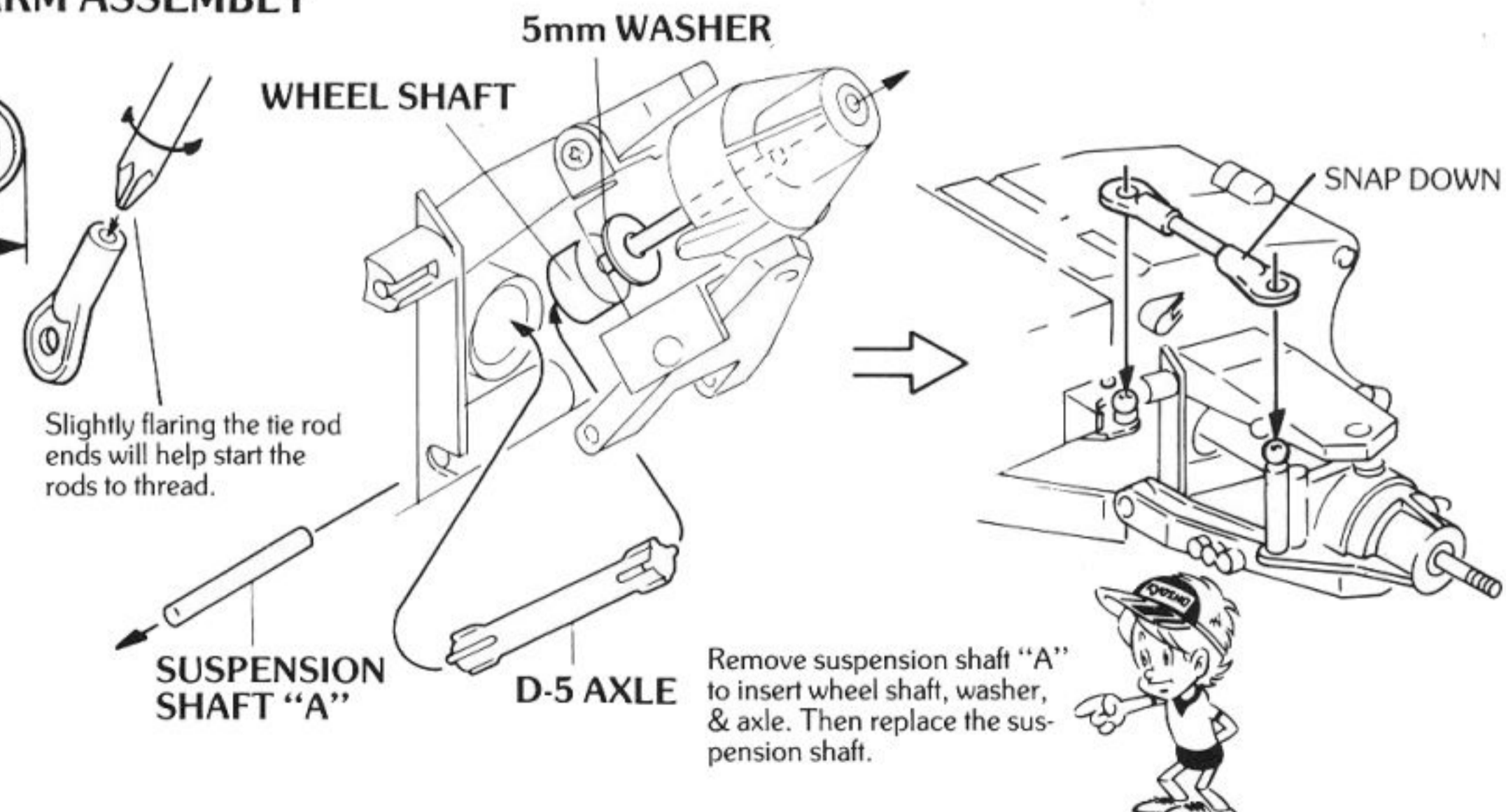
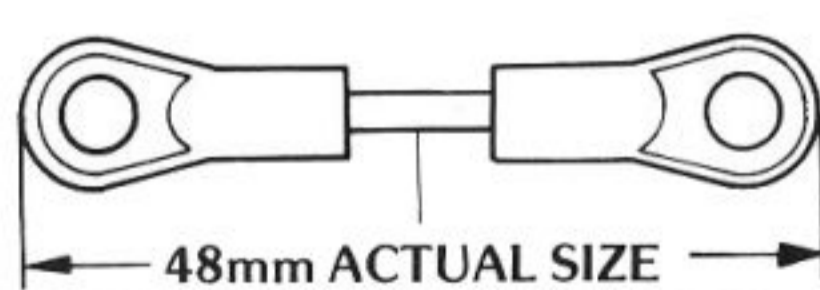

# 13 SHOCK ABSORBER ASSEMBLY

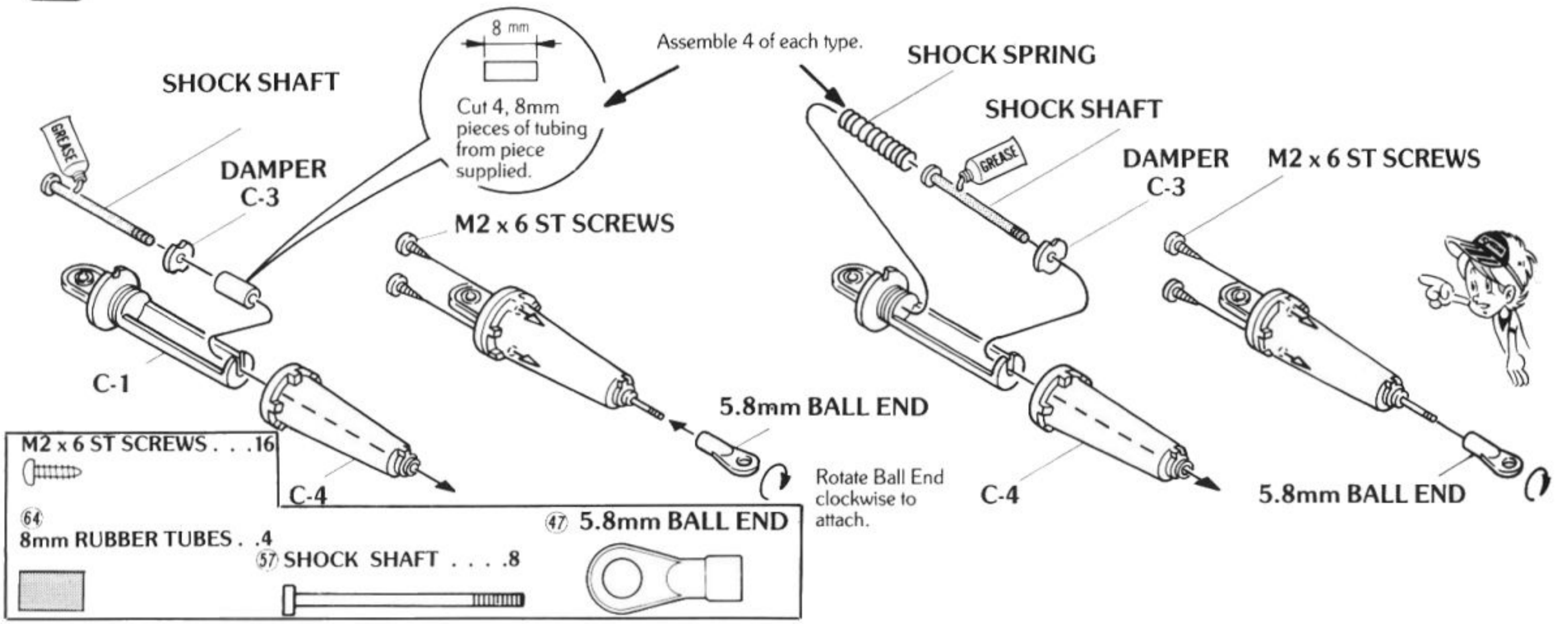

# 14 BUMPER GUARD

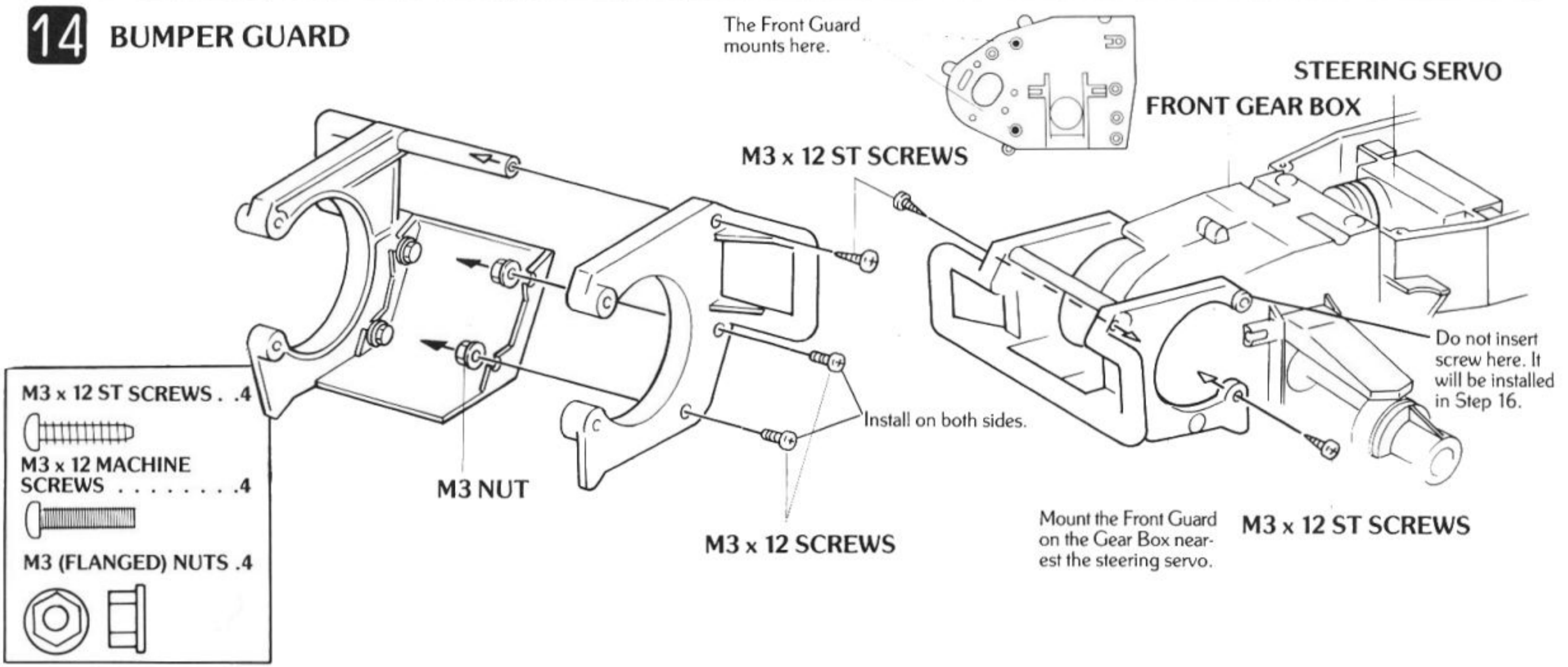

# 15 MOTOR GUARD INSTALLATION

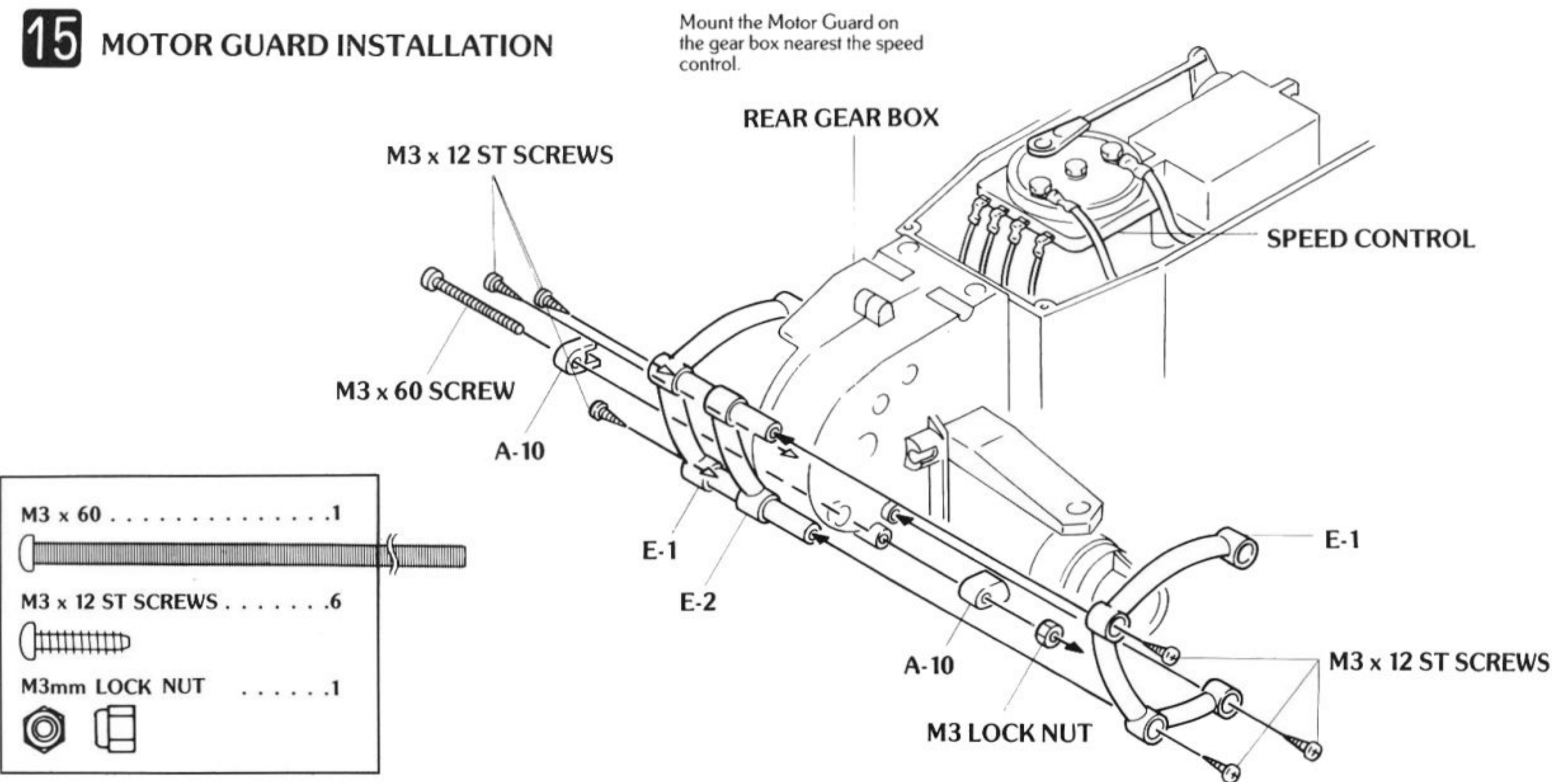

# 16 SHOCK TOWERS

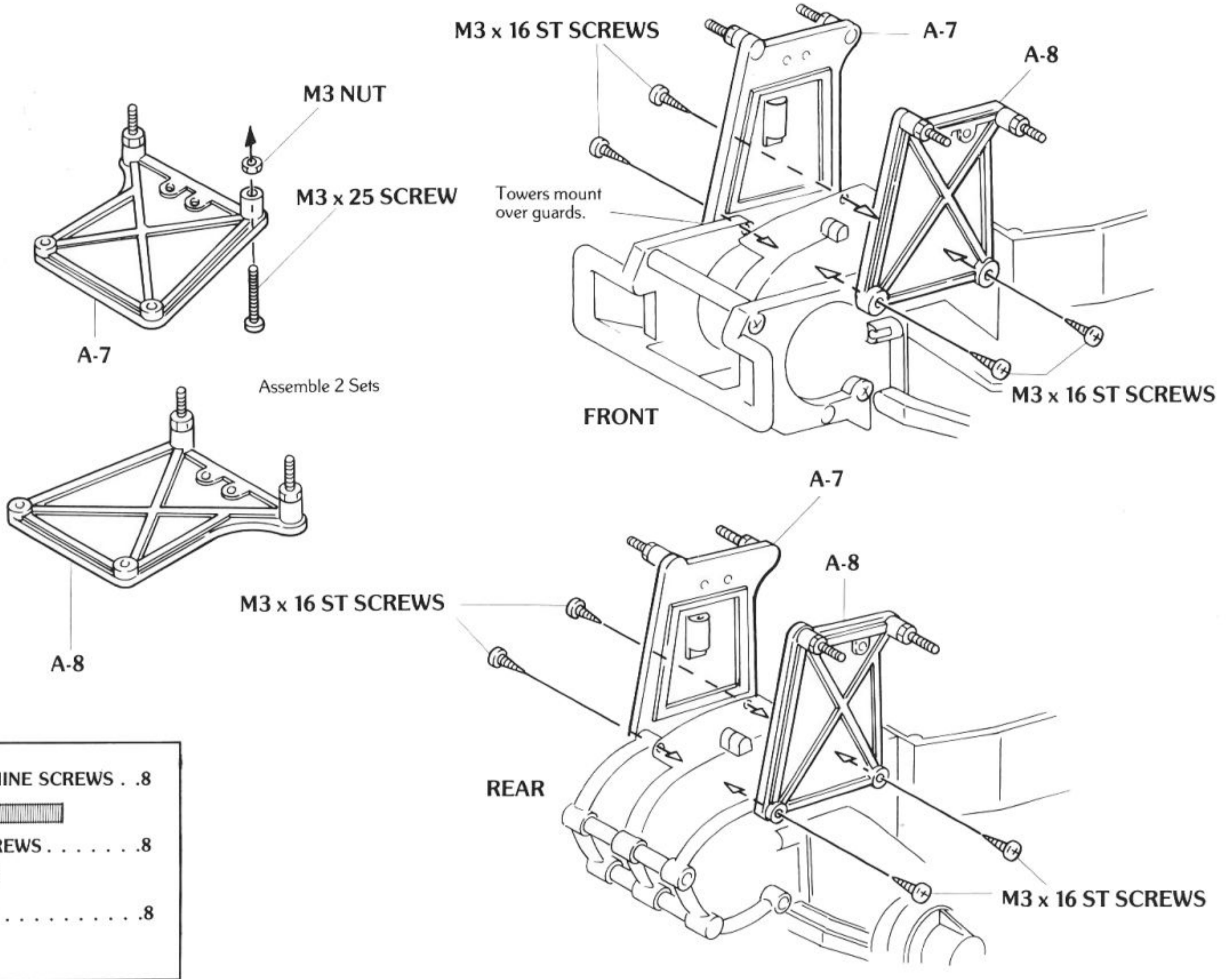

- M3 x 25 MACHINE SCREWS . . . . .8
- M3 x 16 ST SCREWS . . . . .8
- M3mm NUTS . . . . .8

# 17 SHOCK INSTALLATION

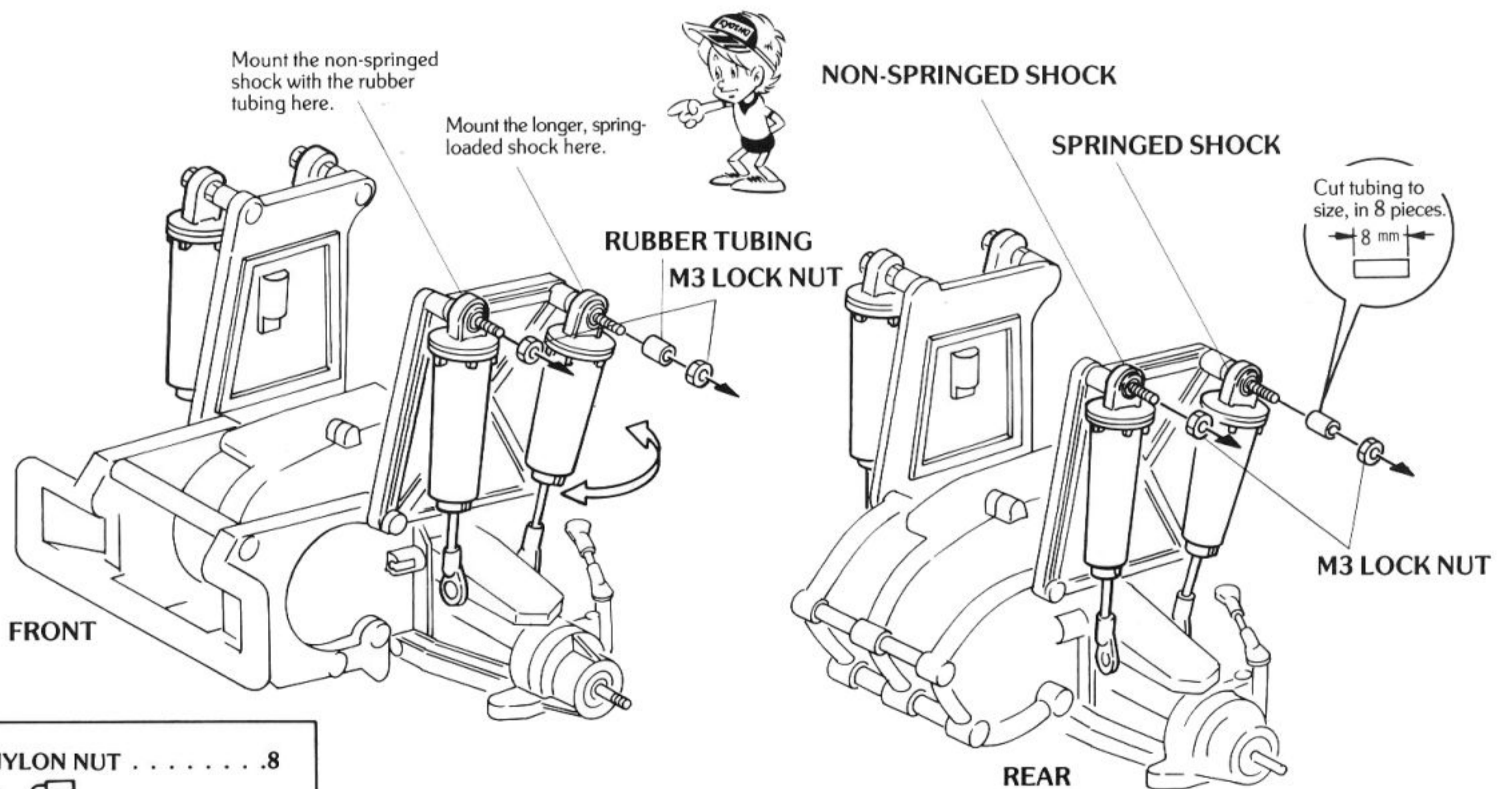

- M3 NYLON NUT . . . . .8
- 8mm RUBBER TUBING . . . . .8

# 18 BATTERY HOLDER

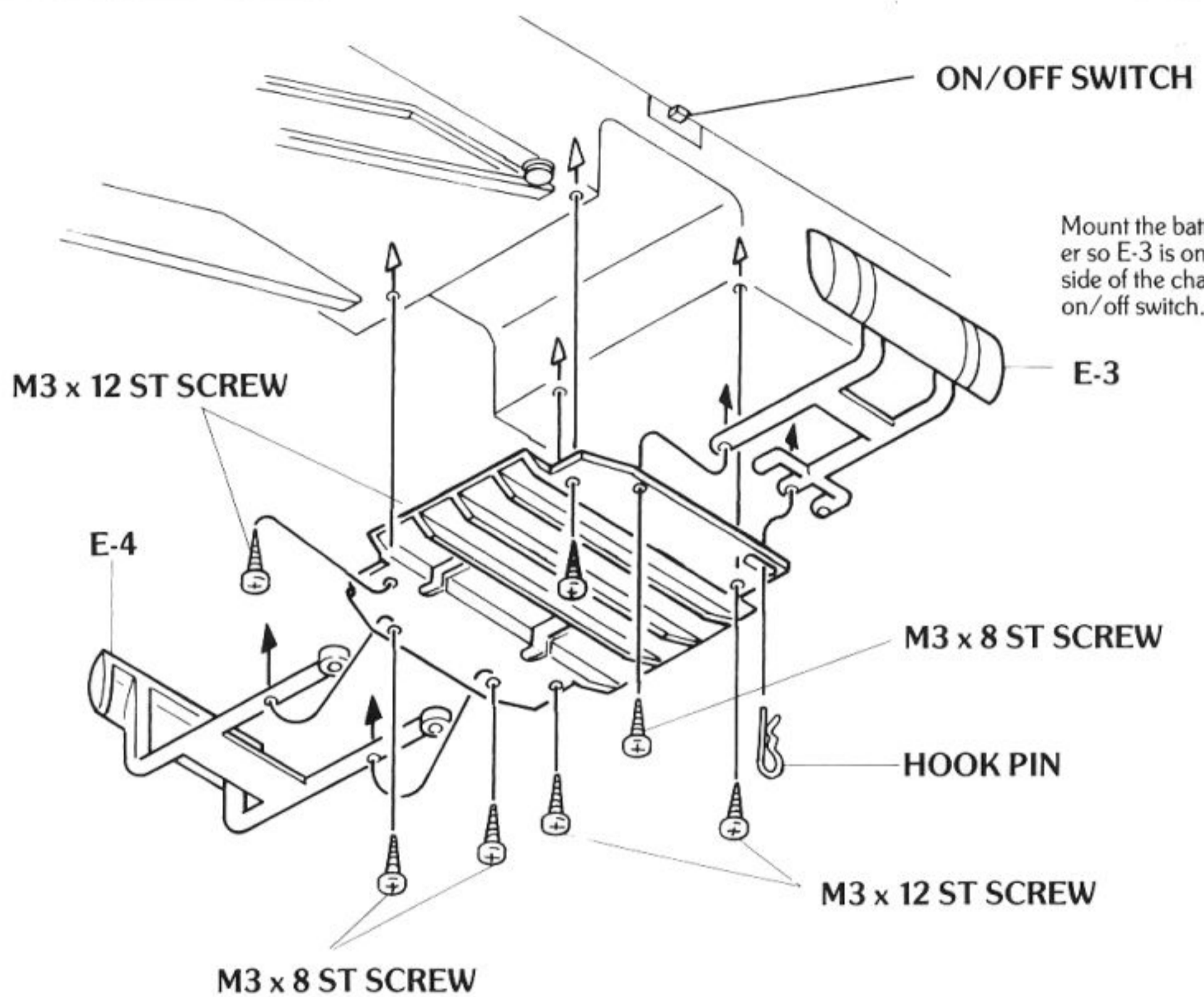

Mount the battery holder so E-3 is on the same side of the chassis as the on/off switch.

- M3 x 12 ST SCREW . . . . . 4
- M3 x 8 ST SCREW . . . . . 3
- 90 HOOK PIN . . . . . 1

# 19 MOTOR INSTALLATION

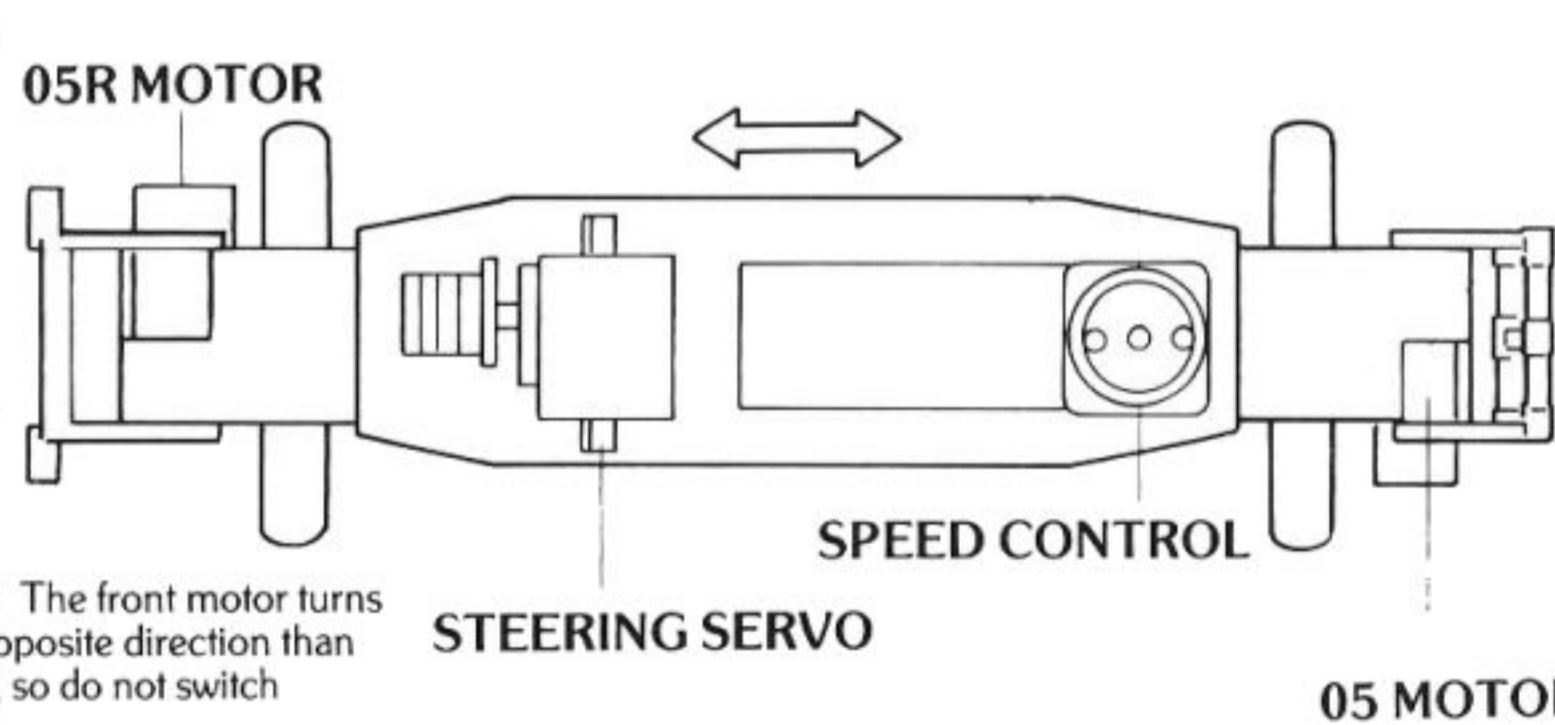
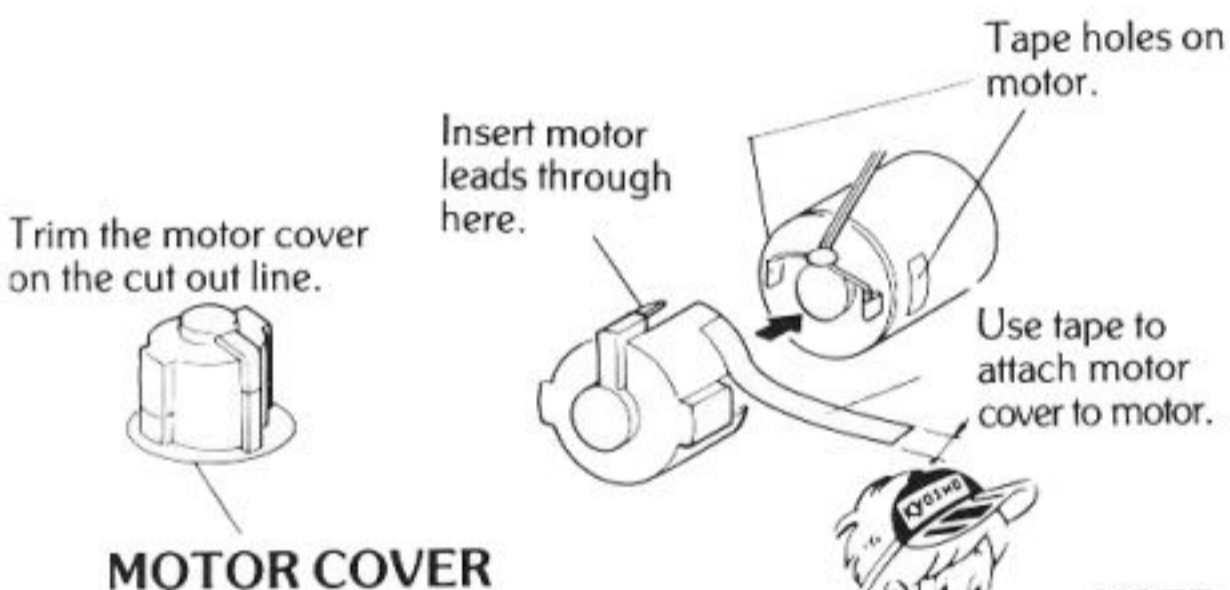
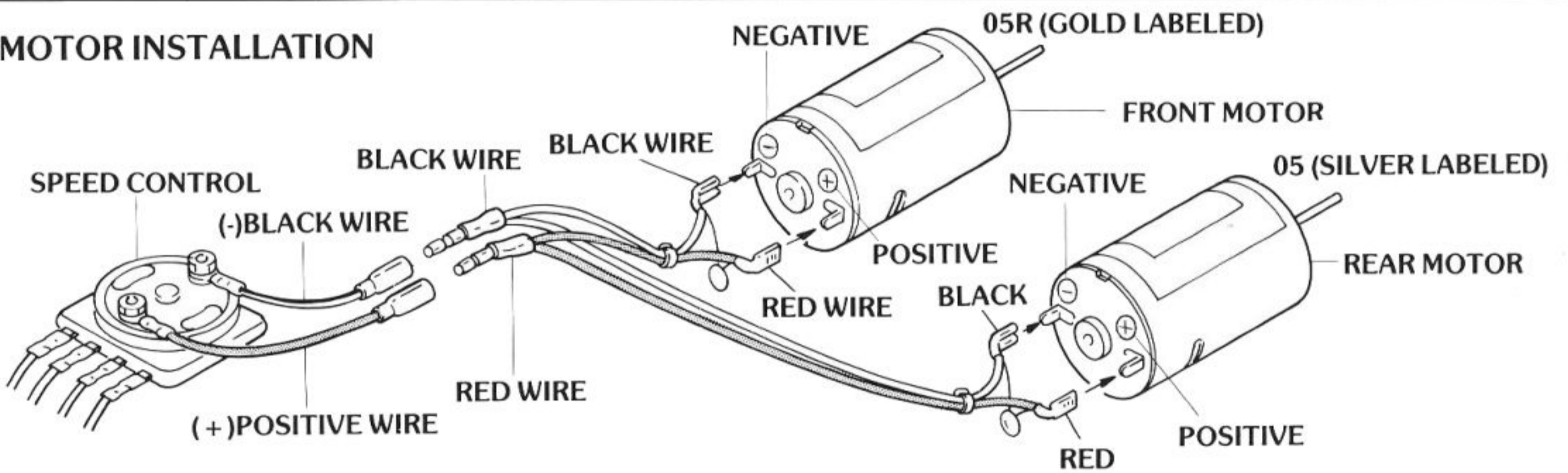

**NOTE:** The front motor turns in the opposite direction than the rear, so do not switch them.

- M3 x 12 ST SCREWS . . . . . 4
- M3 x 28 MACHINE SCREWS . . . 4
- M3mm WASHER . . . . . 4
- M3 x 3 ALLEN SCREW . . . . . 2
- 3 13T PINION GEAR . . . . . 2

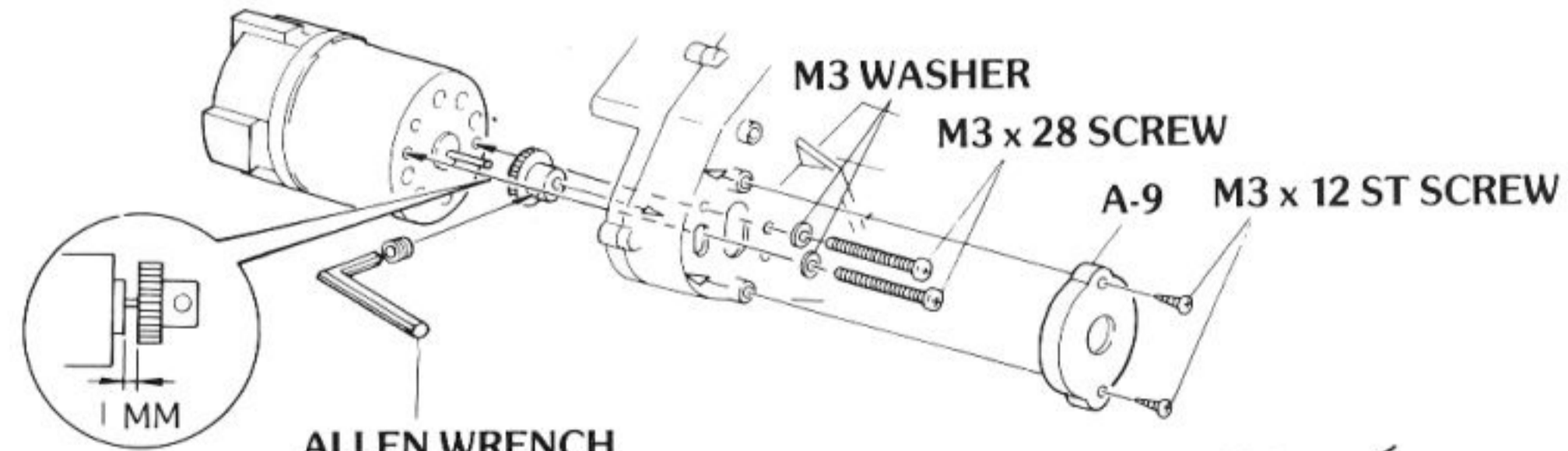

Leave a 1mm gap between the motor and pinion gear.

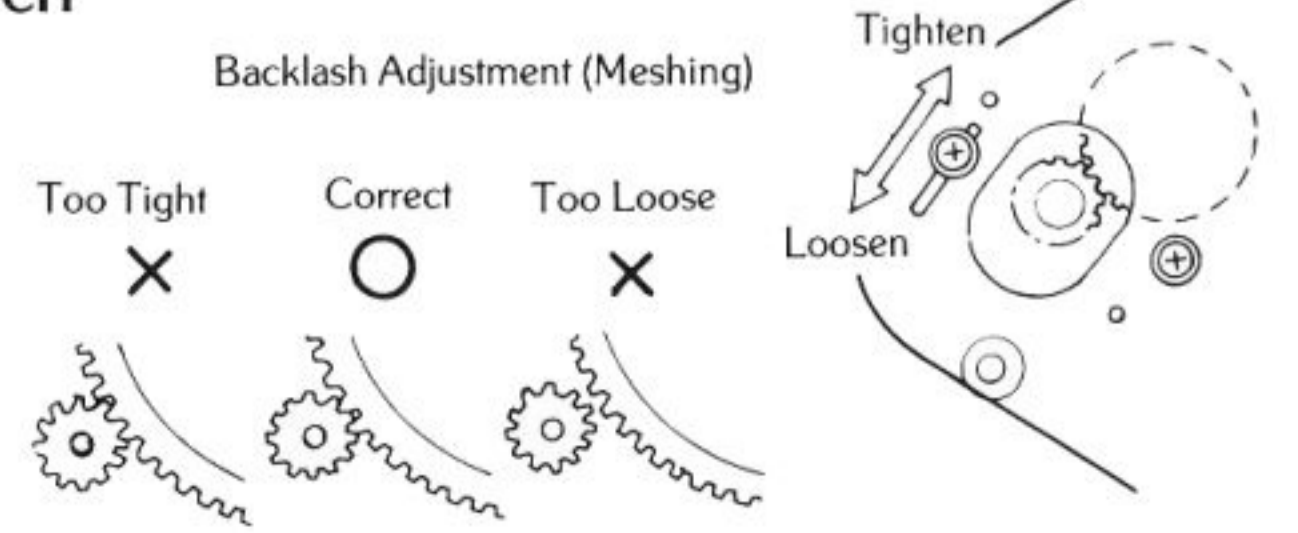

A simple trick for adjusting backlash is to place a piece of paper between the two gears and then tighten them together. Next, remove the paper and you will have the perfect gear mesh.

## 20 RADIO COVER MOUNTING

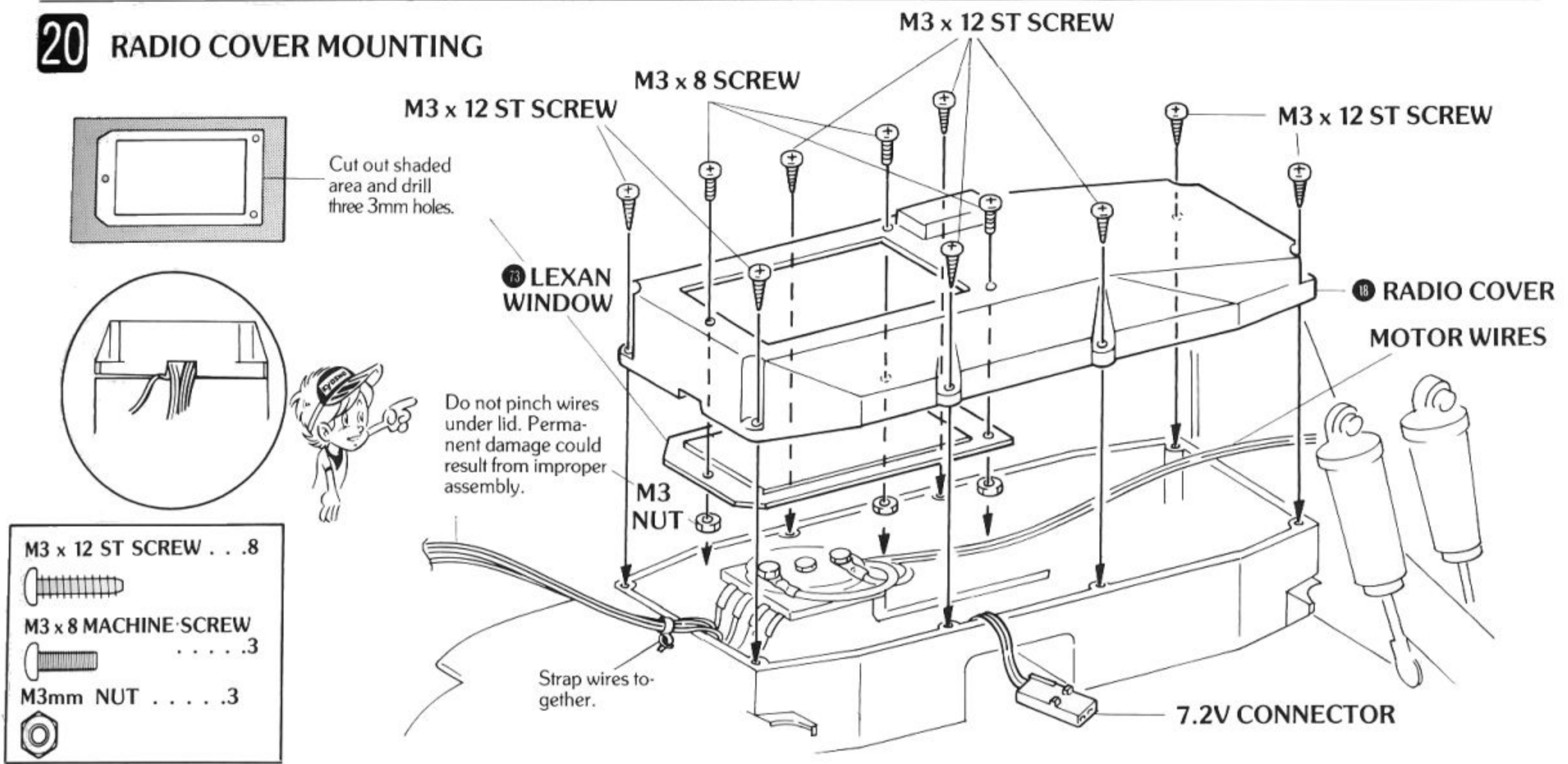

## 21 ENGINE ASSEMBLY

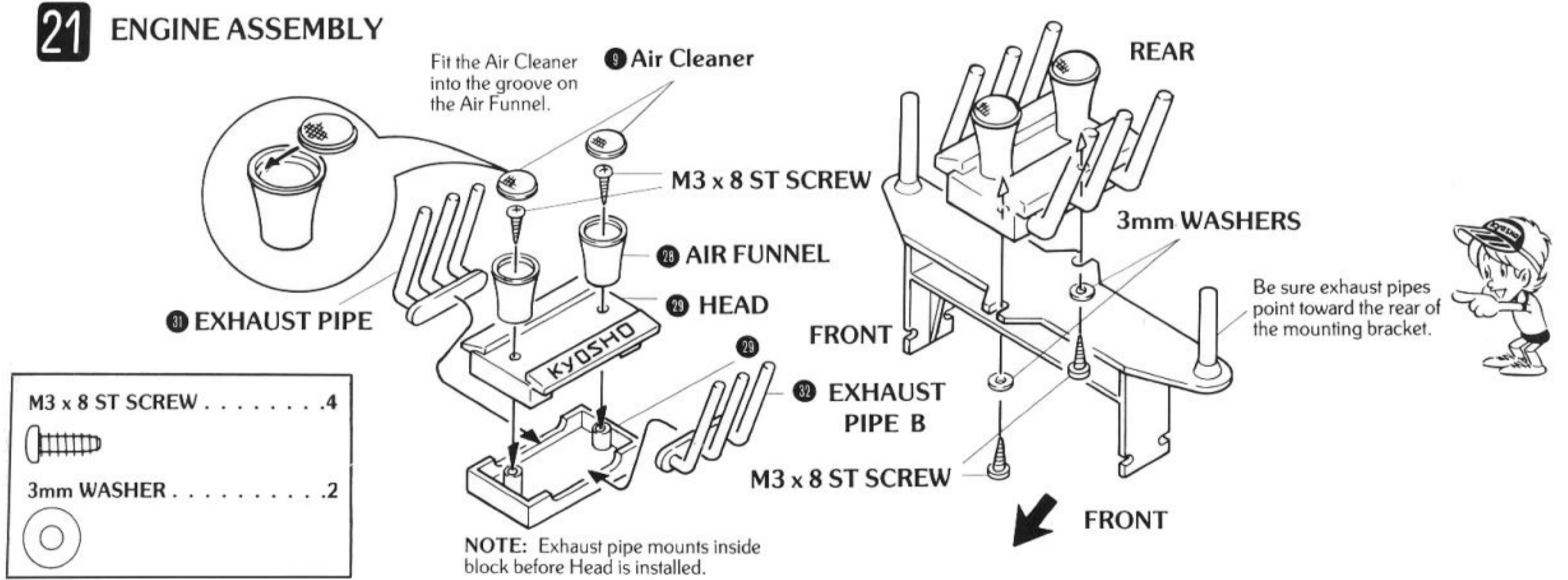

## 22 MOUNTING THE ENGINE AND BODY MOUNT

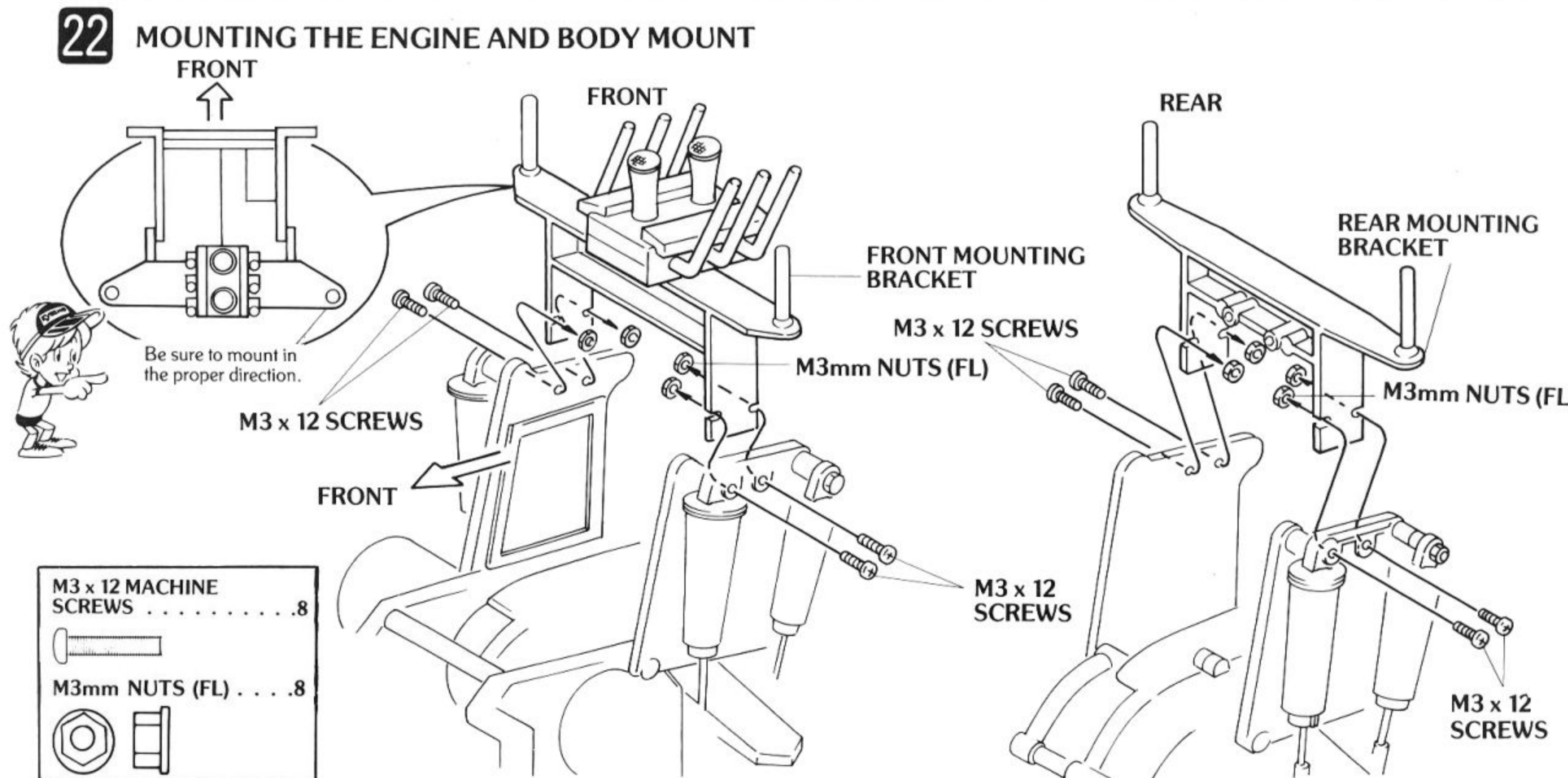

## 23 SPEED CONTROL RESISTOR AND ANTENNA INSTALLATION

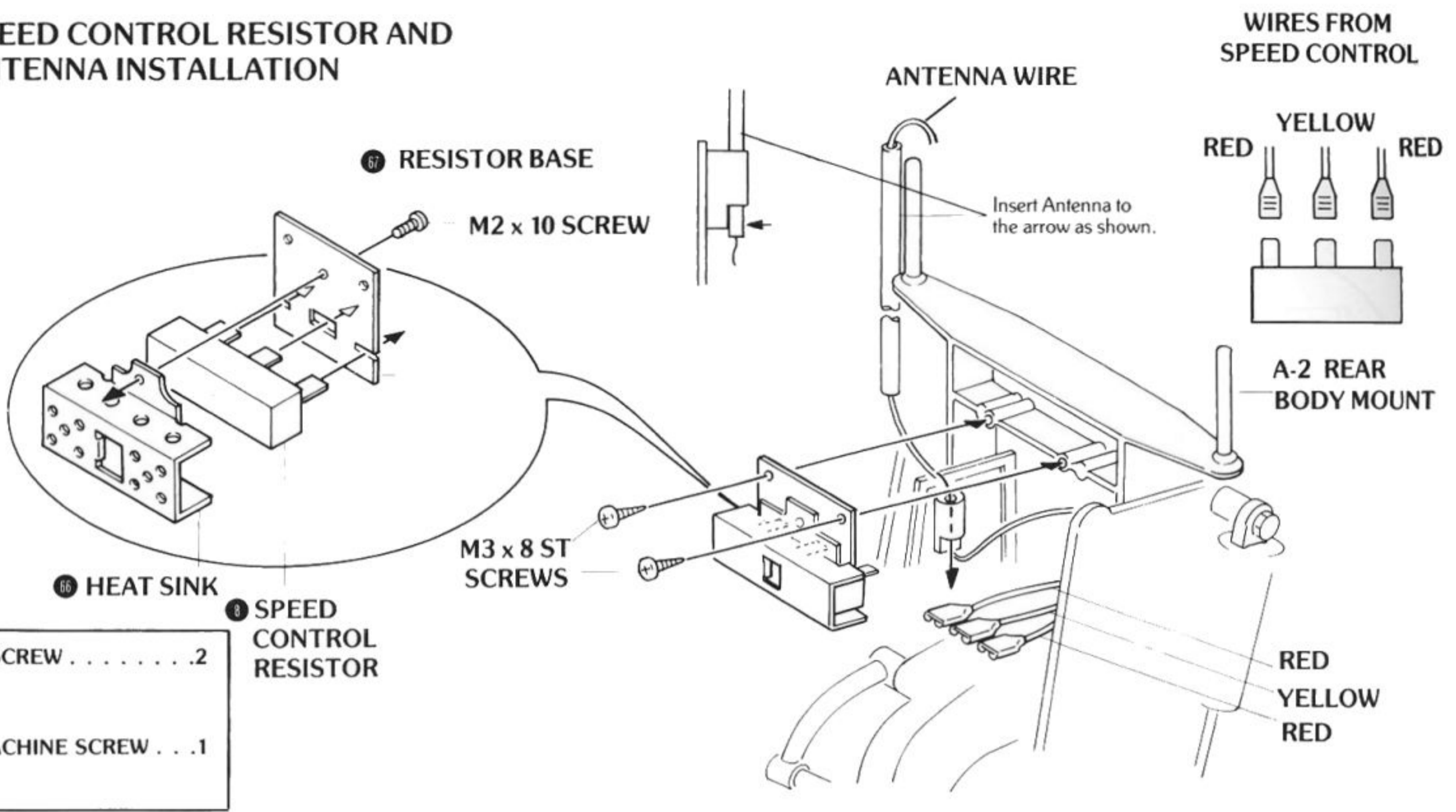

- M3 x 8 ST SCREW . . . . . 2
- M2 x 10 MACHINE SCREW . . . 1

## 24 WHEEL MOUNTING

- M3 x 8 ST SCREW . . . . . 16
- 5mm WASHER . . . . . 4
- M4 NYLON NUT . . . . . 4
- 58 WHEEL SHAFT PIN . . . . . 4 (SILVER)
- 68 WHEEL HUB . . . . . 4

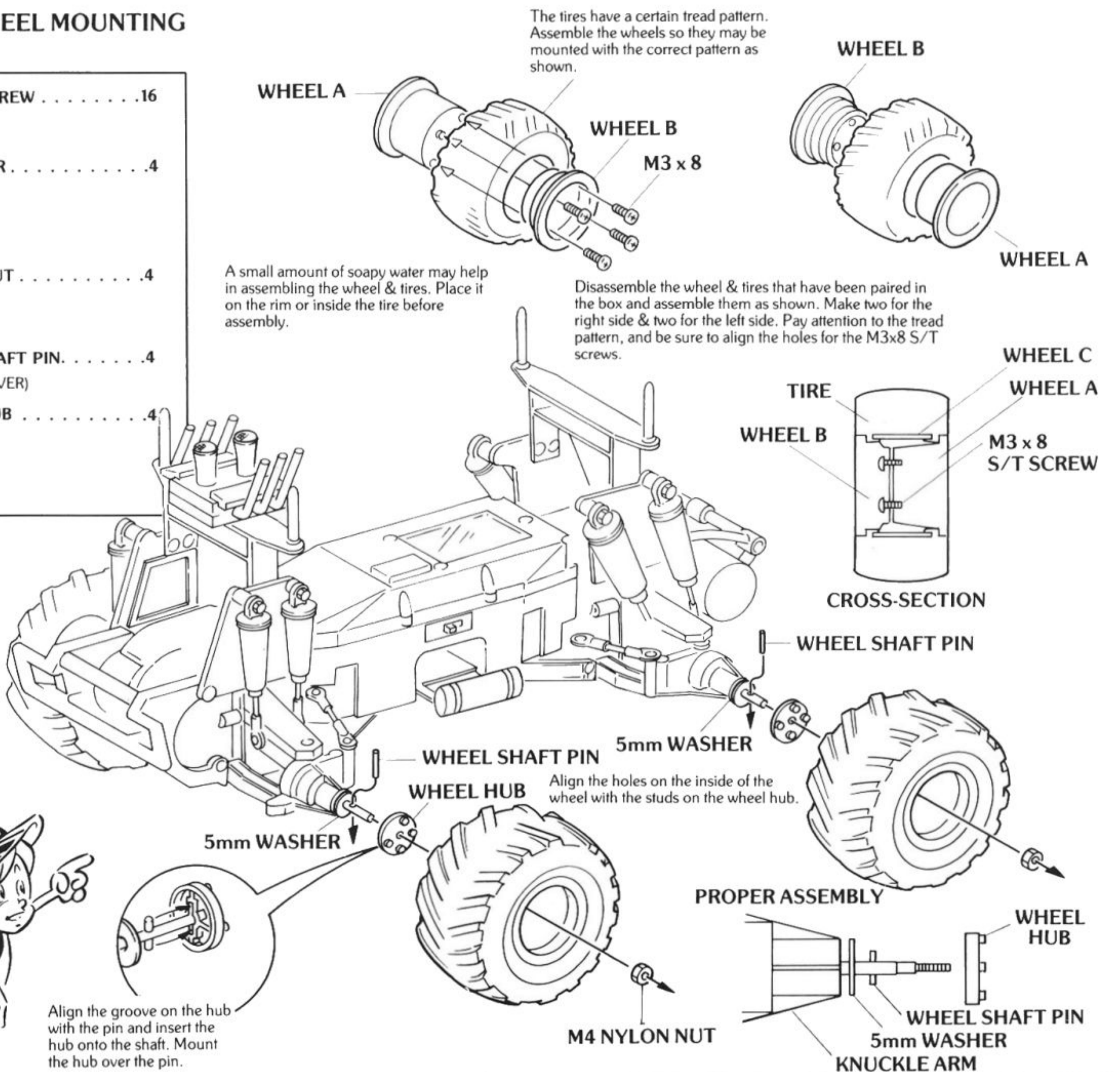

Align the groove on the hub with the pin and insert the hub onto the shaft. Mount the hub over the pin.

## 25 BODY PREPARATION

Carefully remove the shaded area along the cut-out line as shown. Lexan scissors make the job much easier and provide a better finish.

First wash the body to remove any oil or dirt. Rinse thoroughly. Paint the inside of the body. You can obtain a nice color scheme by masking a portion with tape then removing the tape and painting with a different color.

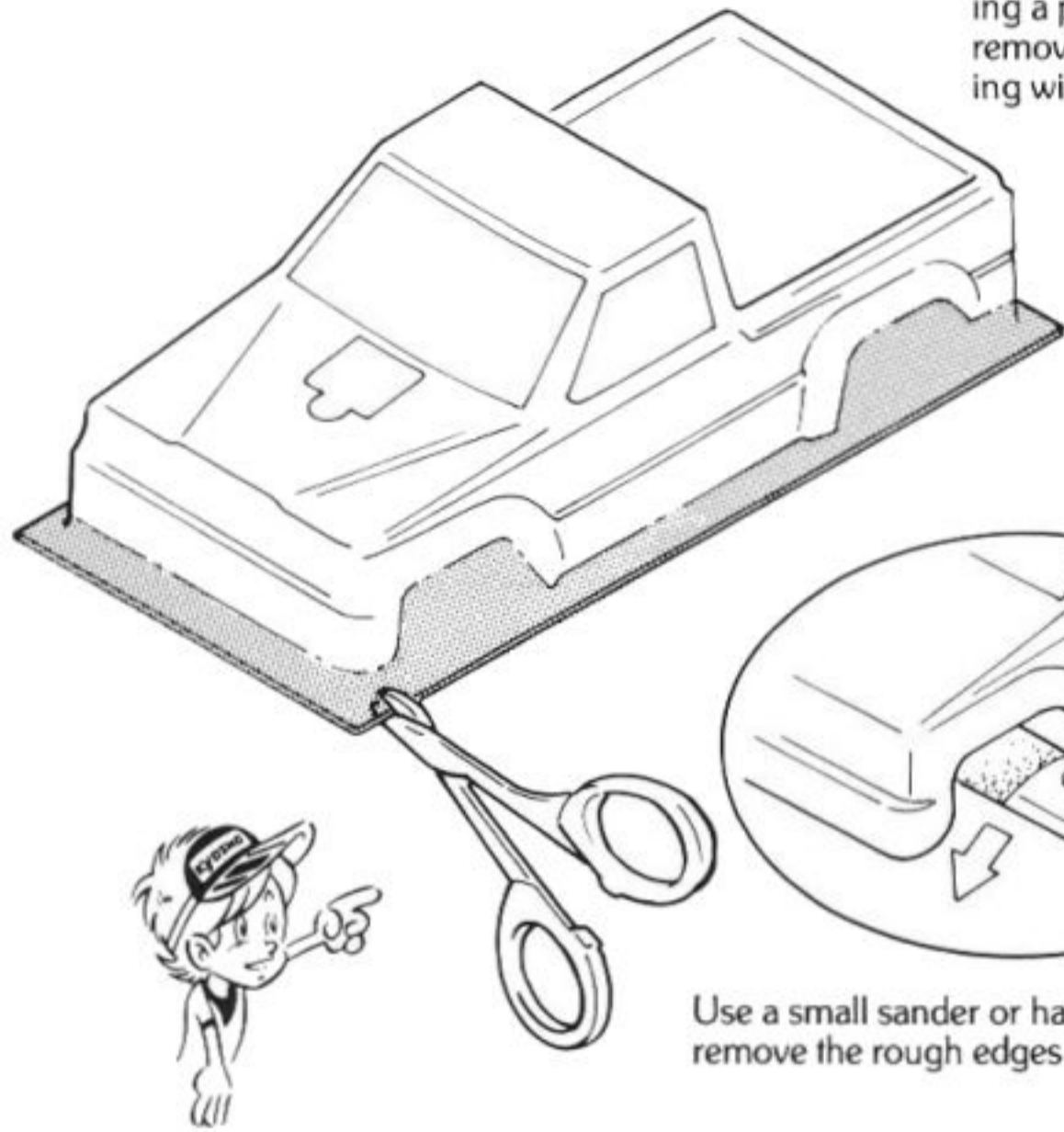

Use a small sander or hand file to remove the rough edges before painting.

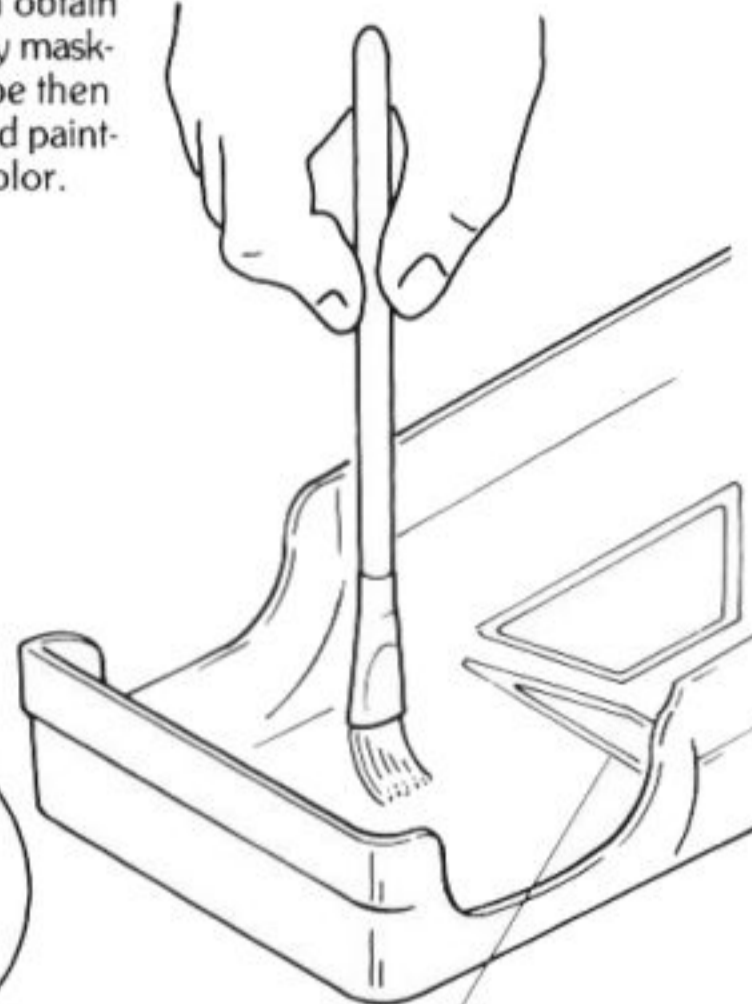

Apply the lightest color last.

Use masking tape on the windows & areas which you choose not to paint with each color.

**KYOSHO**®

These special Lexan scissors make trimming bodies a breeze.

No. 1829

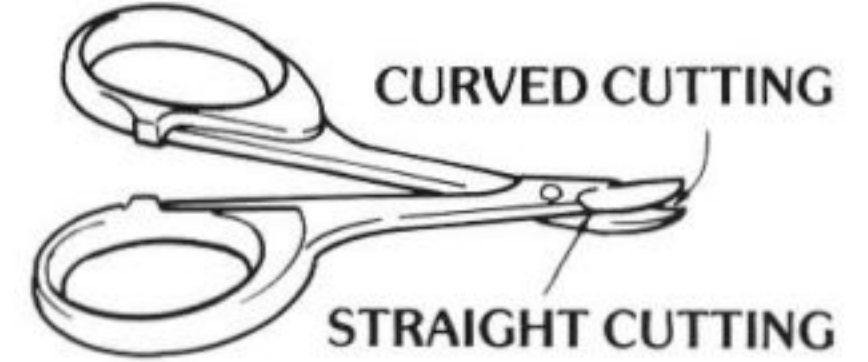

CURVED CUTTING

STRAIGHT CUTTING

**KYOSHO**®

Polyca color paint is available in 12 colors for painting your Lexan bodies.

No. 2230



## 26 BUMPER MOUNTING

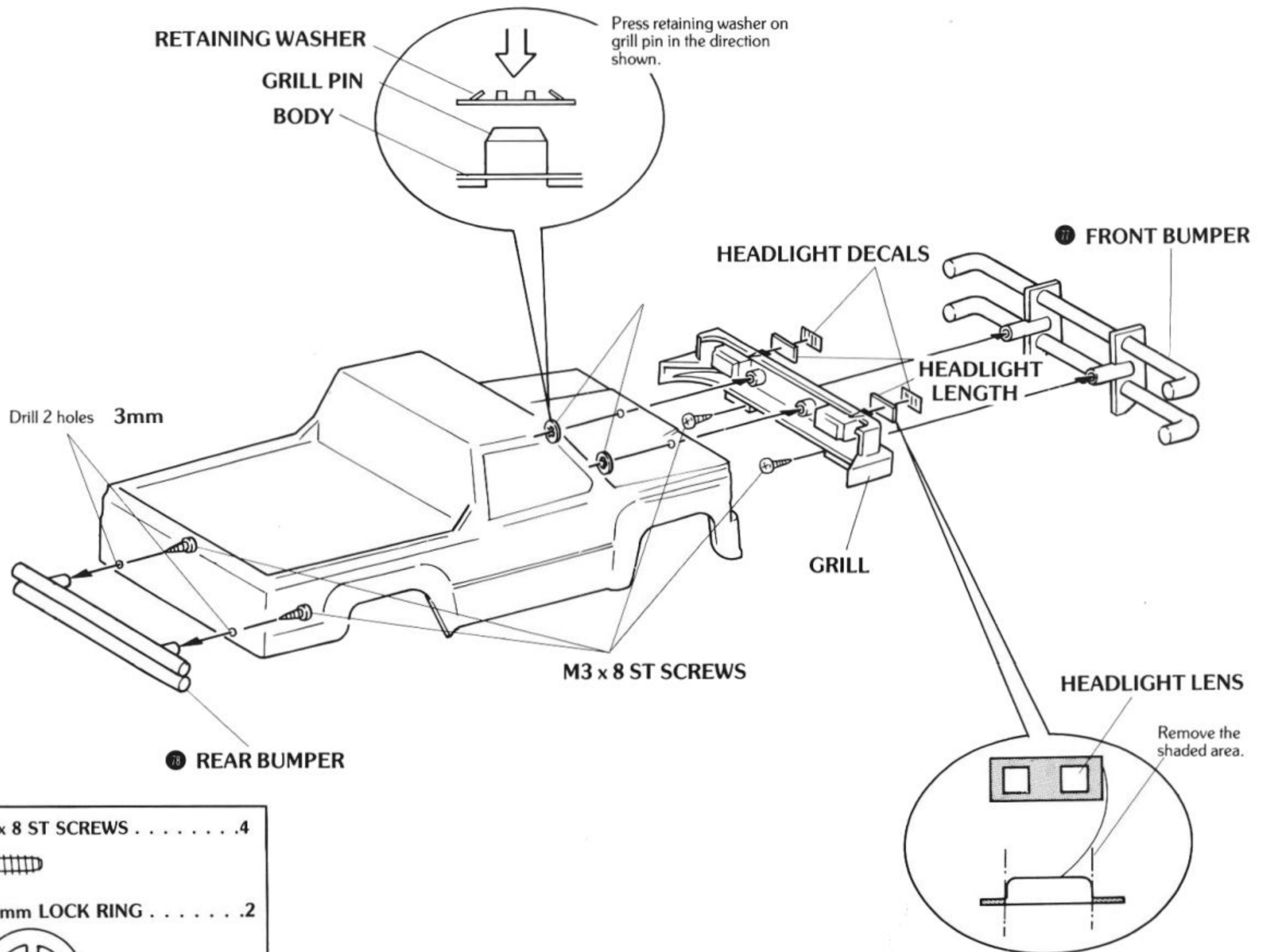

RETAINING WASHER

GRILL PIN  
BODY

Press retaining washer on grill pin in the direction shown.

Drill 2 holes 3mm

HEADLIGHT DECALS

FRONT BUMPER

HEADLIGHT  
LENGTH

GRILL

M3 x 8 ST SCREWS

HEADLIGHT LENS

REAR BUMPER

Remove the shaded area.

M3 x 8 ST SCREWS . . . . . 4

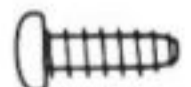

8mm LOCK RING . . . . . 2

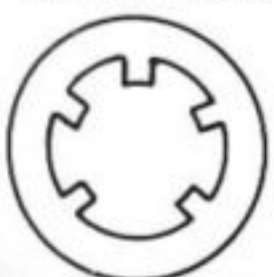

## 27 ROLL CAGE MOUNTING

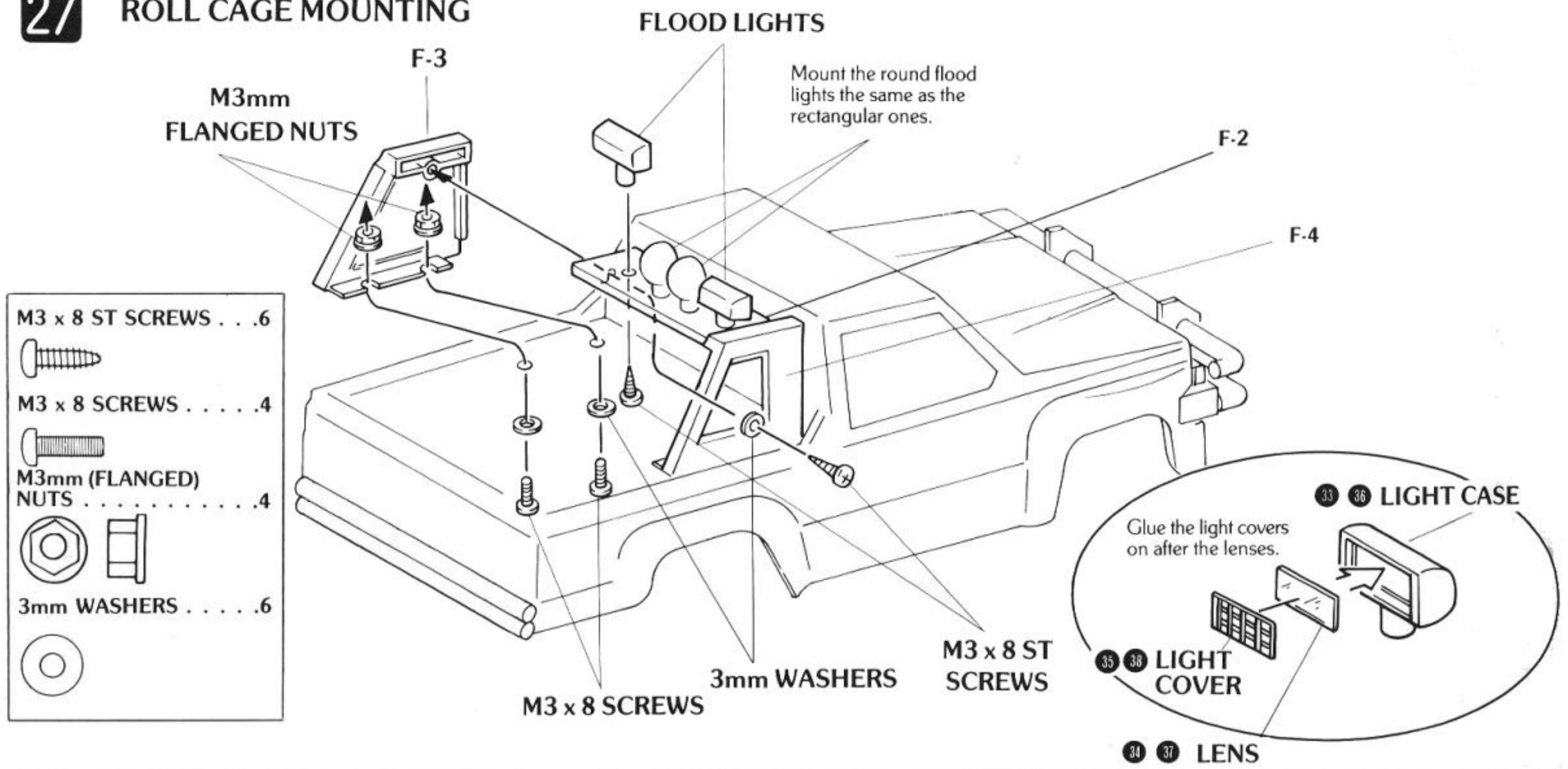

## 28 BATTERY INSTALLATION

Install in order ① - ⑥

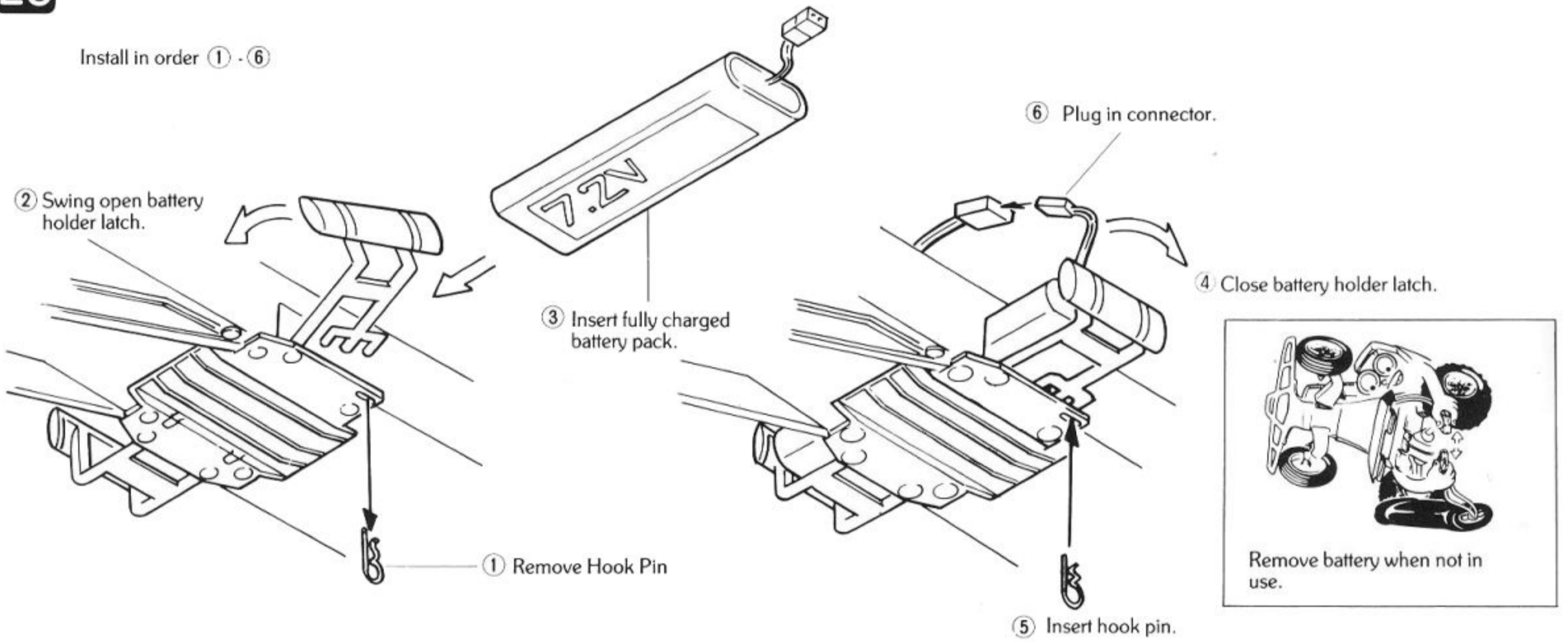

## 29 BODY MOUNTING

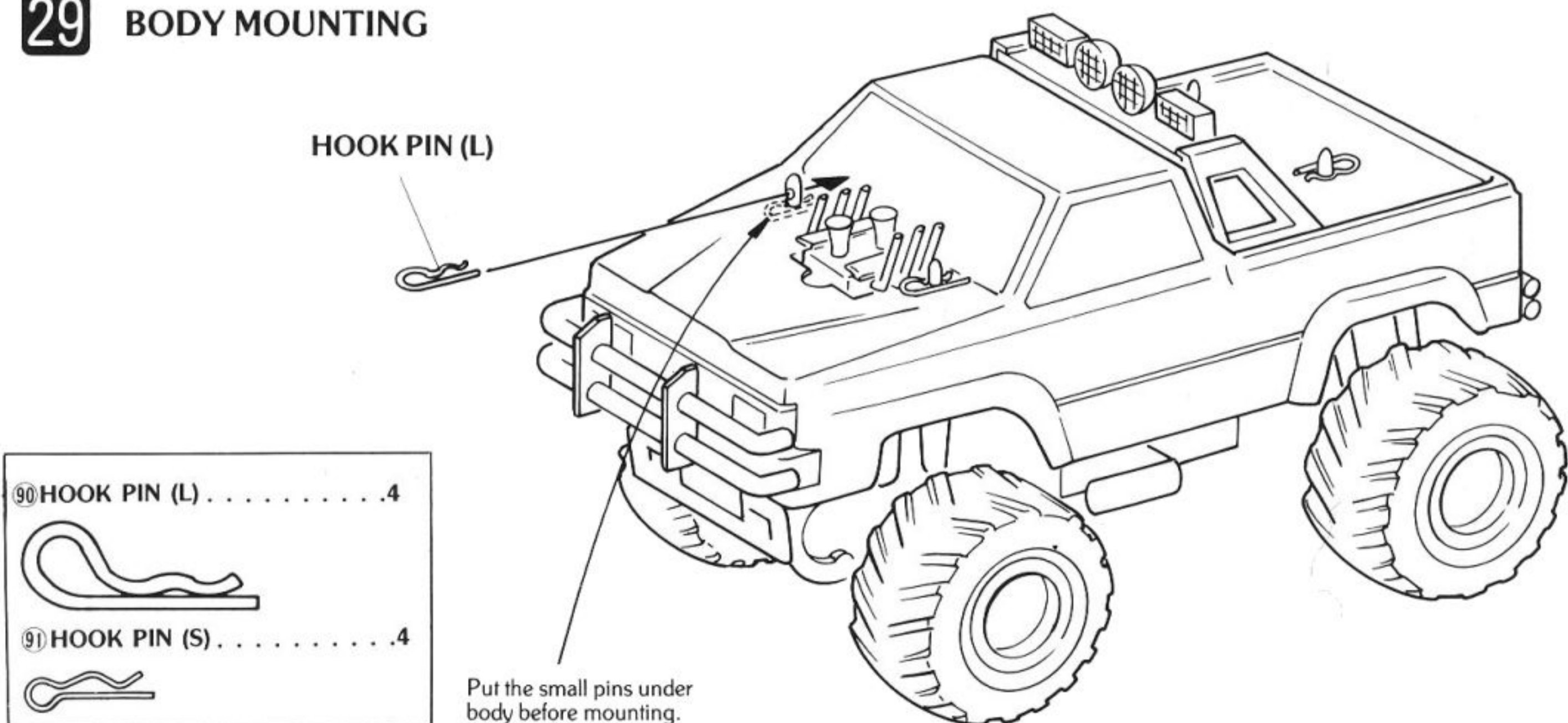

# BASIC ADJUSTMENT GUIDE FOR THE DOUBLE DARE

## TOE-IN ADJUSTMENT

Proper toe-in adjustment is necessary if the Double Dare is expected to perform properly and drive in a straight line without any wandering tendencies.

### FRONT

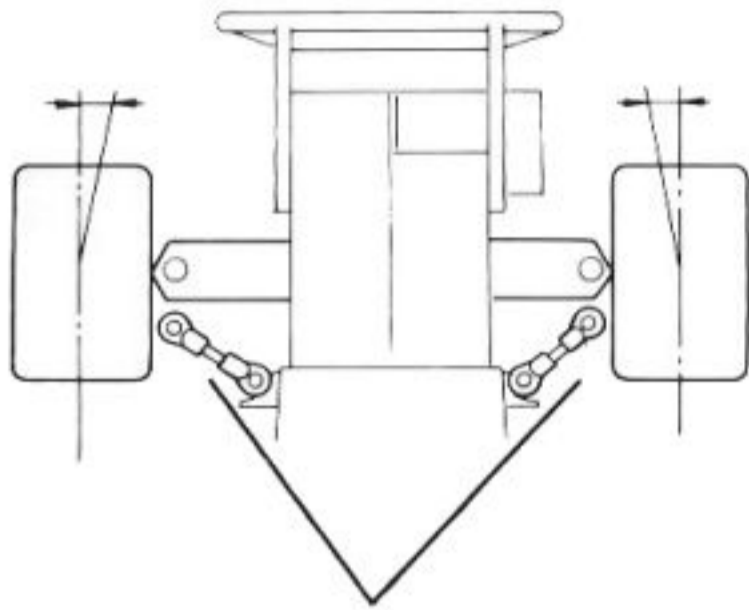

Adjust the toe-in angle of the wheels with the ball links to achieve approximately 1 degree toe-in.

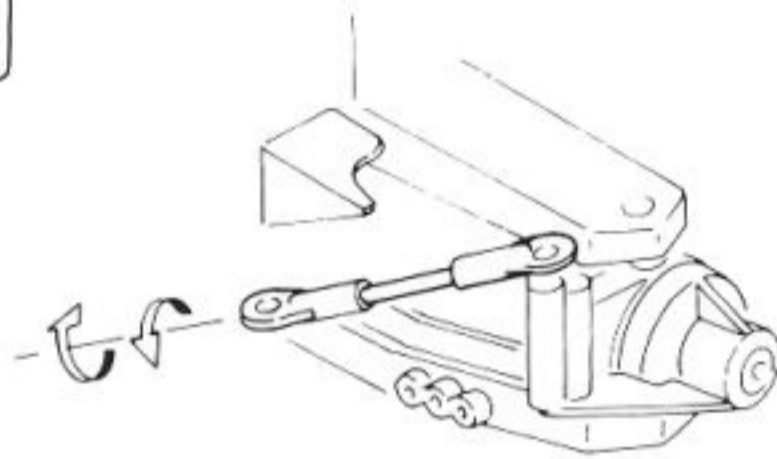

Rotate the ball ends in or out to the desired length.

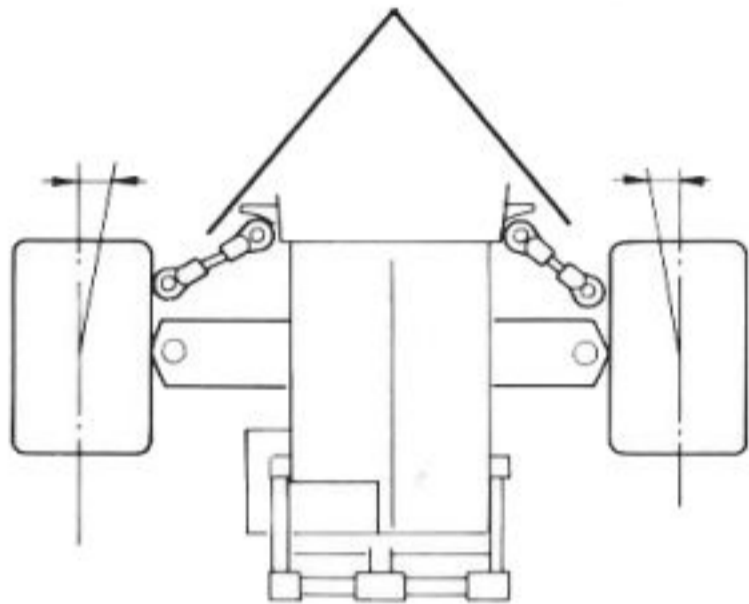

### REAR

## MAINTENANCE

- ★ On the first time, operate the car slowly. Check to make sure the car is operating correctly. Look for nuts, screws and bolts loosening up and tighten as necessary.
- ① Check to see if all nuts and bolts are securely tightened.
- ② Check to see if the batteries for the transmitter, receiver and motor are fully charged.
- ③ Check to see if the front wheels steer in the direction that the transmitter control stick is moved.
- ④ Also check the forward and reverse controls to see if they properly work in the correct directions.
- ⑤ Make sure all wires are properly insulated with all wiring routed that it will not get caught or rub on any moving parts.
- ⑥ Check to see that the rear and front wheels can easily be turned by hand.

## OPERATIONAL CHECK

- ★ To check wheel alignment put the truck on a box to allow wheels to move freely. Then operate the throttle and steering controls and make any adjustments.

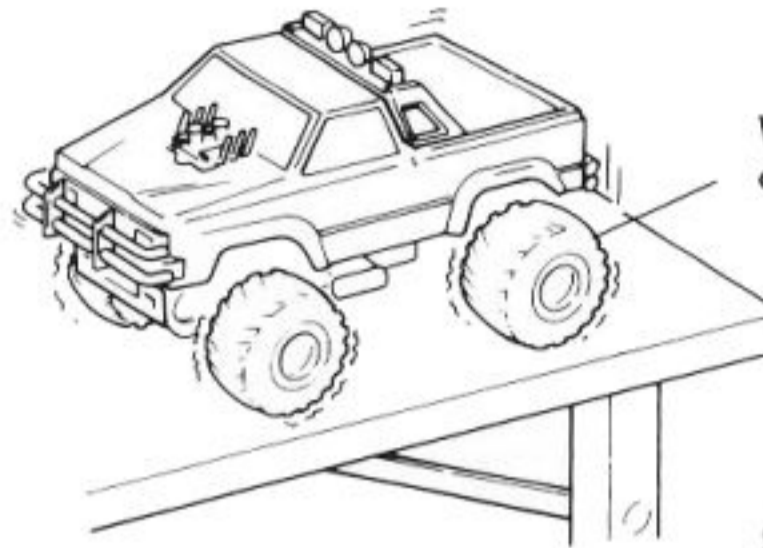

Wheels may not move if the truck is stationary, on the ground.

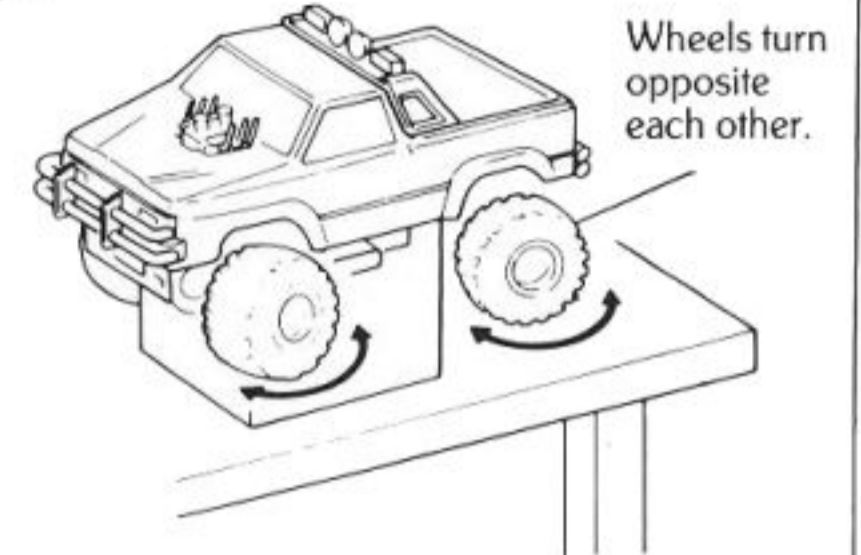

Wheels turn opposite each other.

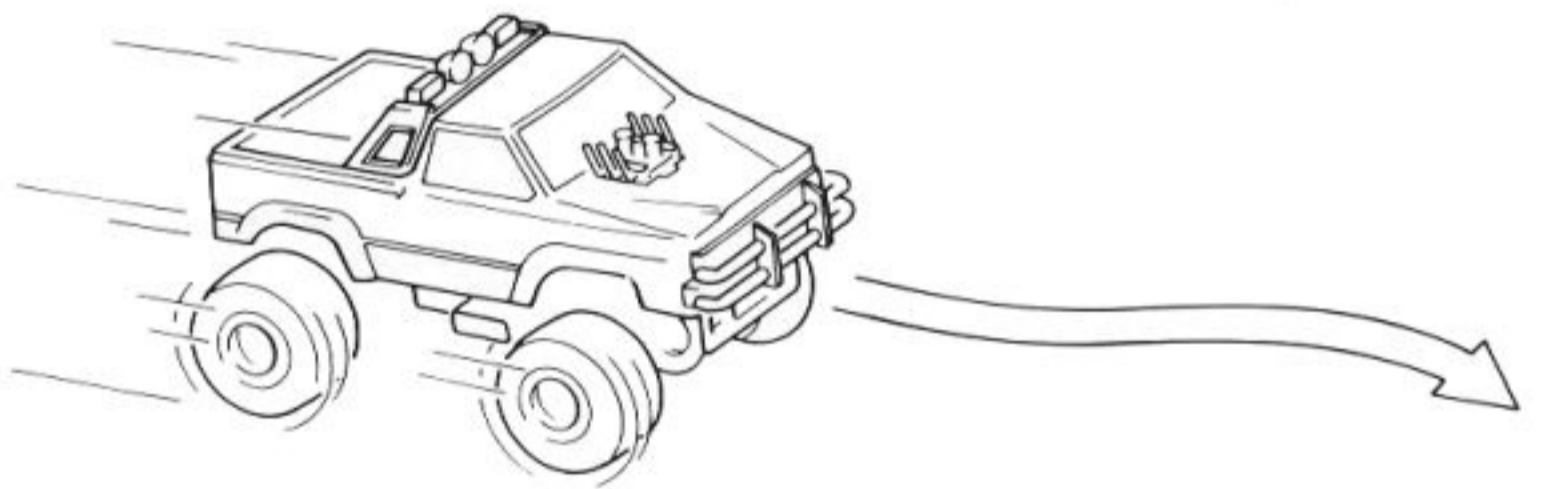

- ★ Do not run the Double Dare for long periods of time in the slower speeds or in reverse as this may cause overheating damage to the speed control resistor.
- ★ The receiver battery and servos in Double Dare are powered from the same battery which drives the motor. If the car slows down considerably, stop the car and turn off the receiver. If you continue to run the car, the battery will get so low on power that you will lose control of it.

## OILING

Applying a small amount of light oil such as Frontier Hobby Oil to the shafts, bearings and ball joints. Wipe off any excess oil with a cloth. Do not use heavy oil or grease as this type attracts and retains mud and dirt while running the car.

Kyosho #1883  
Frontier Hobby Oil



## RADIO OPERATIONAL CHECKLIST

Follow steps 1-8.

It is important to always switch the transmitter on first . . . then the receiver. When turning off the system, turn off the receiver first and then the transmitter.

1. Install the batteries into both the transmitter and receiver. If your radio is a rechargeable system, charge it as outlined in the manual that came with your set.
2. Unwind the receiver antenna and plug the servo and battery connectors into the receiver.
3. Extend the transmitter antenna.
4. Turn on the power switch of the transmitter.
5. Turn on the power switch of the receiver.
6. Set the small trim levers to the center position and make sure that both main control sticks are also centered.
7. Move both main control sticks slowly through their full travel. The servo horns should move in proportion to the movement of your sticks.
8. When trim levers and sticks are at their neutral positions, the servo horns should be centered. You may now turn off the receiver, then the transmitter and unplug the servos and battery from the receiver.

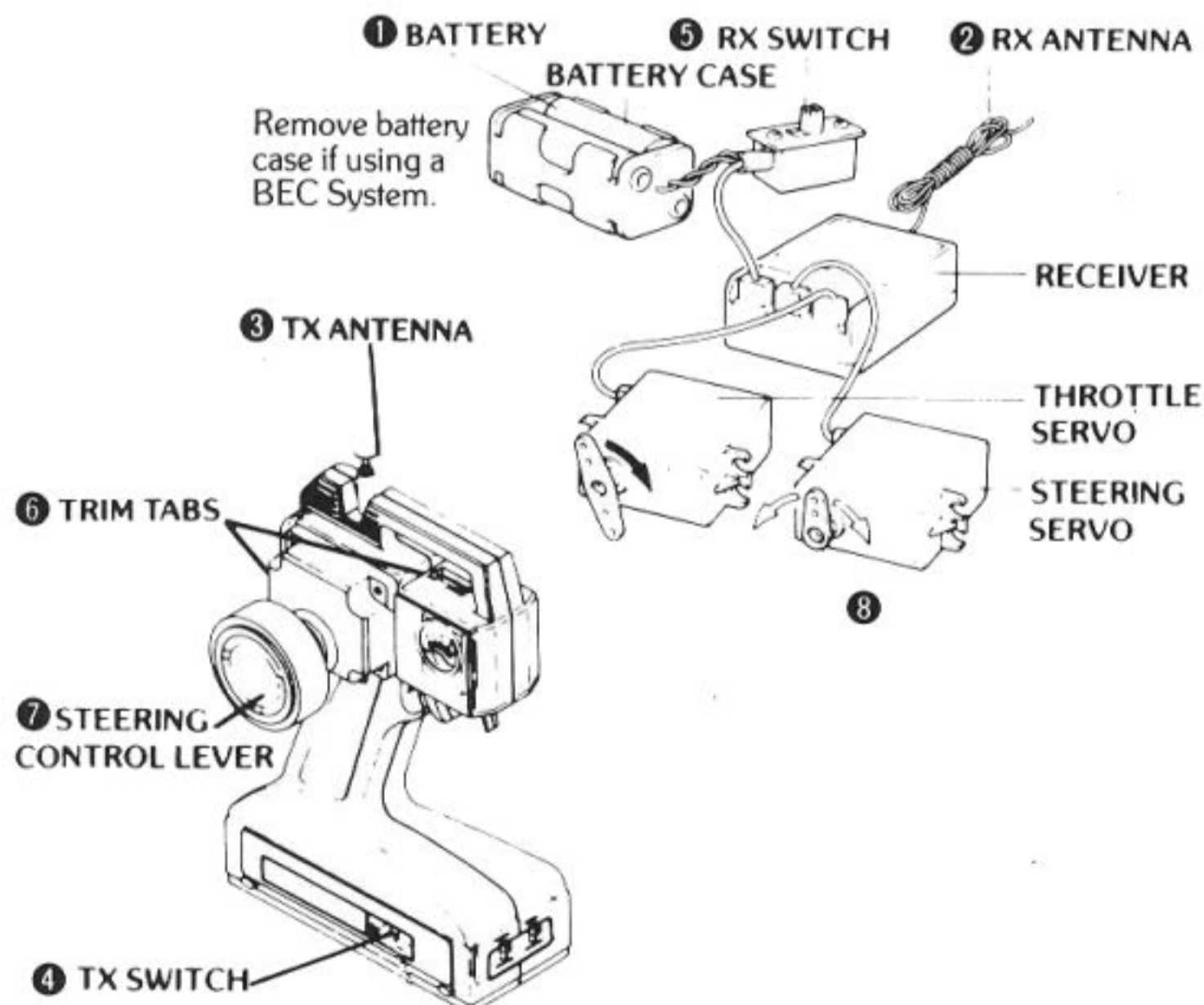

## PARTS LIST

KEY NO.	QTY	KEY NO.	QTY	KEY NO.	QTY	KEY NO.	QTY
1	.8	25	.1	49	.2	73	.1
2	.16	26	.1	50	.2	74	.1
3	.1	27	.1	51	.4	75	.1
4	.4	28	.2	52	.2	76	.1
5	.1	29	.1	53	.8	77	.1
6	.1	30	.1	54	.4	78	.1
7	.2	31	.1	55	.4	79	.2
8	.1	32	.1	56	.4	80	.1
9	.2	33	.2	57	.8	81	.1
10	.2	34	.2	58	.4	82	.1
11	.2	35	.2	59	.8	83	.4
12	.2	36	.2	60	.1	84	.4
13	.2	37	.2	61	.1	85	.4
14	.4	38	.2	62	.1	86	.4
15	.4	39	.4	63	.1	87	.1
16	.1	40	.4	64	.2	88	.2
17	.1	41	.4	65	.1	89	.2
18	.1	42	.2	66	.1	90	.5
19	.2	43	.2	67	.1	91	.4
20	.4	44	.6	68	.4	92	.4
21	.1	45	.2	69	.2	93	.4
22	.1	46	.1	70	.4	94	.2
23	.1	47	.16	71	.1	95	.1
24	.1	48	.2	72	.1	96	.1

### PURCHASING PARTS FOR YOUR KIT

You can purchase replacement and optional parts for your kit. All of the parts identified by key numbers (see above) are usually not available singularly, but we offer these parts in convenient parts "packs" which can be purchased separately. To figure out which parts pack you need, find the key number for that part within the manual. Then consult our parts pack guide, below. When referring to the parts you need, always use the **Parts Pack Numbers**. For instance, if you need an Exhaust Pipe (Key #32) ask your dealer for Kyosho Parts Pack #DA-4 (Engine Set).

STOCK #	PART #	DESCRIPTION	CONTAINS	RETAIL \$
KYOC4018	DA-01	Gearbox Set	10 x 1 11 x 1	\$8.00
KYOC3606	DA-02	Frame Set	16 x 1 17 x 1 18 x 1 19 x 1	22.30
KYOC3702	DA-03	Front Guard Set	22 x 1 23 x 1 24 x 1 25 x 1 26 x 1 27 x 1	12.80
KYOC3447	DA-04	Engine Set	28 x 2 29 x 2 30 x 1 31 x 1 32 x 1 33 x 1 34 x 1 35 x 1	16.00
KYOC4429	DA-05	Light Set	36 x 2 37 x 2 38 x 2 39 x 2	11.20
KYOC2235	DA-06	F Block Parts	40 x 1	9.60
KYOC4198	DA-07	Grill Guard Set	41 x 1 42 x 1	8.70
KYOC2349	DA-08	A Block Parts	43 x 1 44 x 1	8.00
KYOC2363	DA-09	E Block Parts	45 x 1	6.40
KYOC5644	DA-10	Shaft Set	46 x 1 47 x 1 48 x 1 49 x 1 50 x 1 51 x 2 52 x 1 53 x 2 54 x 2 55 x 2 56 x 2 57 x 4 58 x 4 59 x 2 60 x 2	16.00
KYOC5752	DA-11	Small Parts Set	61 x 1 62 x 1 63 x 1 64 x 2 65 x 2 66 x 4 67 x 1 68 x 1 69 x 1 70 x 1 71 x 1 72 x 1 73 x 1 74 x 1 75 x 1	12.80
KYOC4606	DA-12	Motor Cord	76 x 1	6.40
KYOC6241	DA-13	Spike Tire Set	77 x 2	22.50

STOCK #	PART #	DESCRIPTION	CONTAINS	RETAIL \$
KYOC6322	DA-14	Wheel Set	84 x 2 85 x 2 86 x 2 88 x 2	\$12.80
KYOC3217	DA-15	Decals	81 x 1	8.00
KYOC2411	DA-16	Body	87 x 1	28.80
KYOC5457	DA-17	Screw Set	88 x 2 89 x 2	19.20
KYOC6066	BB-03	Suspension & Rim Set	1 x 4 2 x 1 3 x 1 4 x 2 5 x 2 6 x 4 7 x 4	12.80
KYOC4147	BB-06	Gear Set	8 x 2 9 x 2 10 x 1 11 x 1 12 x 1 13 x 3	11.20
KYOC2237	BB-08	5.8 Ball link Set	14 x 12 15 x 12	9.60
KYOC2359	BB-12	C Block Parts	16 x 1	6.40
KYOC5368	BB-14	Wheel Shafts	17 x 2	8.00
KYOZ2353	PI-04	DZ Block Parts	18 x 1 19 x 1	8.00
KYOC4601	PG-37	Motor Cover	20 x 2	4.80
KYOC4767	OT-050	Pinion Gear (13T)	21 x 1	4.10
KYOC2520	EP-22	Body Pin	22 x 5	1.60
KYOC2517	1889	Hook Pin	23 x 5	1.60
KYOC5753	1815	Rotary Controller	24 x 1 25 x 1 26 x 1	18.95
KYOC5823	1819	15w Resistor Set	27 x 1 28 x 1 29 x 1	3.80
KYOG1922	1922	Stock 05 Motor	30 x 1	22.95
KYOG1928	1928	05R Motor	31 x 1	22.95

#### OPTIONAL PARTS

KYOC2207	1903	Ball Bearings (4x8)	2 pc.	\$6.95
KYOC2297	1901	Ball Bearings (5x10)	2 pc.	6.95
KYOC2216	PI-15	Ball Bearings (8x12)	2 pc.	16.00
KYOC5693	W-5002	Gold Shocks (L)	2 pc.	34.95
KYOC5704	W-5004	Platinum Shocks (L)	2 pc.	39.95
KYOC5681	1951	Shock Oil (3ml)	(L-M-H)	12.80
KYOC5732	OT-038	Silicone Grease		4.80
KYOC4708	1883	Frontier Hobby Oil	1 pc.	18.70
KYOC4602	SC-040	Motor Cover	1 pc.	5.70
KYOC4762	OT-023	Pinion (12T)	1 pc.	4.10
KYOC4771	OT-051	Pinion (14T)	1 set	4.10
KYOC4427	1856	Fog Light Set	1 set	19.95
KYOC4428	NB-13	Light Set	1 pc.	10.20
KYOG1897	1897	LeMans 480 Gold Motor	1 pc.	72.95
KYOG1926	1926	LeMans H240S Motor	1 pc.	62.95
	H-012	Complete Bearing Set	1 set	52.95

NOTE: PRICES SUBJECT TO CHANGE WITHOUT NOTICE.



PRINTED IN JAPAN

## KYOSHO SPEED CONTROL MAINTENANCE PROCEDURE

Certain high performance parts like the Kyosho Speed Control require routine maintenance to ensure continued reliability in operation. We suggest that you perform the following maintenance procedures after each day of racing for continued peak performance.

### Refer to Figure #1 for proper maintenance procedure.

1. Remove center bolt 'A' to disassemble.
2. Inspect wire holding nuts 'B' and 'C' for tightness. Tighten if loose.
3. Check contact 'D' for free vertical movement.
  - A. If binding exists, remove wire holding nuts 'B' and 'C' to disassemble contact mechanism for cleaning.
4. Clean all dust and dirt from the contact pad areas 'E' and 'F'. A pencil eraser can also be used to burnish the contact pad areas.
5. Reassemble speed controller.
  - A. Make sure the control rod 'G' does not strike one of the wire nuts 'B' and 'C'. If this occurs, the control rod must be repositioned.
  - B. Check that the supply wire terminals 'H' and 'J' turn freely in the rotor when it is moved through its full duration.

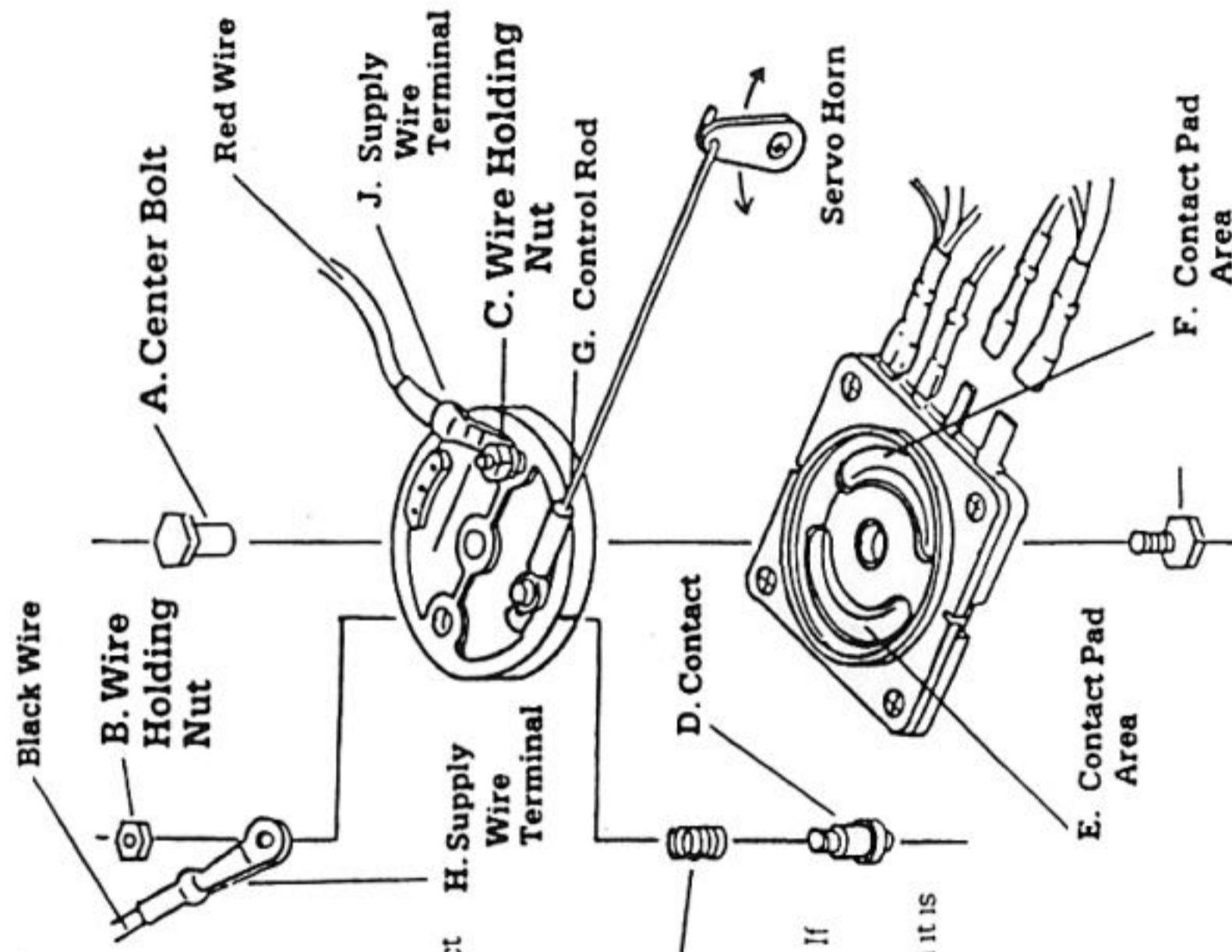

The Kyosho Speed Control comes with an extended warranty. If it should require repair or fail to operate, please contact Kyosho's authorized U.S. repair facility for warranty repair or replacement.

Kyosho U.S.A.  
1610 Interstate Drive  
Champaign, IL 61821  
Phone #217-398-0007



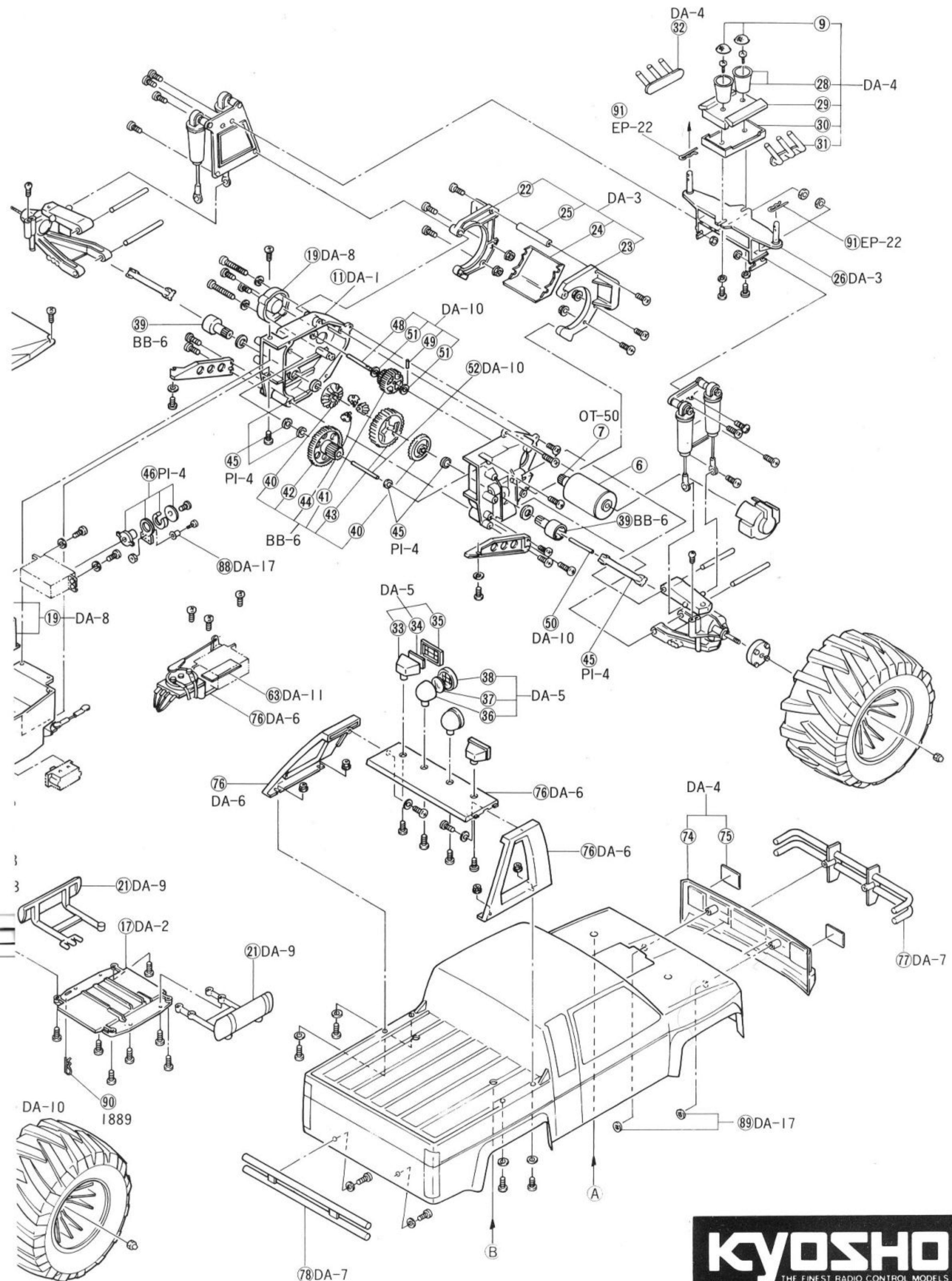

**KYOSHO**<sup>®</sup>  
 THE FINEST RADIO CONTROL MODELS