

RADIO CONTROLLED ELECTRIC POWERED RACING BUGGY

4WD OFF-ROAD RACER TURBO ROCKY

- HIGH-SPEED THRILLS FOR NEWCOMER AND EXPERT!
 - STRENGTHENED FOR 8.4V POWER!
 - QUALITY DESIGN AND MATERIALS.
- FOUR-WHEEL DRIVE BY LIGHTWEIGHT STEEL CHAIN. RELIABLE AND STRONG.
 - EASY ASSEMBLY AND ADJUSTMENT.
 - METAL-GEAR DIFFERENTIALS FRONT/REAR.
- COMBINED UNIVERSAL JOINT/HALFSHAFT FOR MECHANICAL RELIABILITY AND STRENGTH.
 - ALLOY ALUMINUM CHASSIS. RUGGED DESIGN.

1:10 SCALE

BATTERY : 8.4V-1200mAh

MOTOR : LeMANS-240/360TYPE

RAD10 : 2ch.

(NOT INCLUDED)



KYOSHO
THE FINEST RADIO CONTROL MODELS

◀ KIT NO. 3103 ▶

BEFORE ASSEMBLY

***Read the Instruction Carefully.**

You can assemble the kit more easily if you have grasped the general idea of steps and structure beforehand by reading it through to the end.



***Check the Parts in the Kit**

Check to see if all the parts are correctly bagged as they are listed in the "List of Bagged Parts."



Your thorough understanding of the assembly will enable you to build the kit without any difficulty. Check the components in the kit prior to your starting the assembly. Any claims for replacements or refunds for the model in the process of assembly will not be accepted.

***Learn the Marks described in the Instruction.**



Points where grease should applied. (It will reduce friction and assure smooth movements.)



Places to put some locktite. (It will prevent the screws and nuts get loosen by Vibration while running.)



Steps where you particular attention is required.

***Be well aware of the Different types of screws.**

1. The difference between the TP screw (short form of self-tapping screw) and the ordinary screw is. . .

Self Tapping Screw

Ordinary Screw

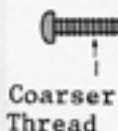

Some of them have pointed tips.

2. The kinds of screws which will be used in this instruction.

Truss Screw

Round and bigger head



(There are two kinds of thread, finer and coarser ones.)

Flat Head Screw

A shape of dish



(")

Tap Tight



(Finer thread and tapered tip.)

Set Screw



A hexagonal hollow in place of screw head.

Bind Screw

Big and flat Head



***Pick up the correct parts and screw**

Compare the shape and size of small parts, such as screws, nuts, and washers with the attached sheet of "List of Small Parts."



***Be sure about the location and direction of parts to install.**

Double-check the location and orientation of parts with the illustration before installation. When necessary, assemble the parts themselves tentatively before proceeding to the next step.



***Do not tighten the self-tapping screw too tight.**

Do not use excessive force when tightening the self-tapping screws, or you may strip the thread in the plastic. It is recommended to stop tightening it when the threaded part on the screw goes into the plastic part and you feel some resistance from the tightening.

Good

Over tighten may strip the thread in the plastic.

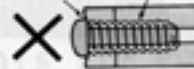

Wrong

THINGS NEEDED BESIDES THE KIT

(2 Channel Radio System)

Two types of radio control set are on the market, the stick type and the steering wheel type. Choose which ever you like.

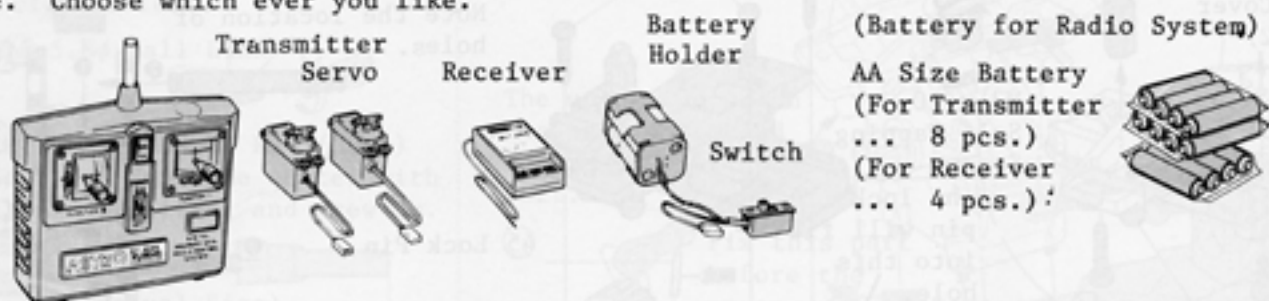

(Ni-Cad Battery)

"Turbo Rocky" is designed to use a rechargeable 8.4V Ni-Cad battery pack. A Kyosho Racing Battery, part number 1932 (and some other brands) may be recharged at a wide range of rates. The charging rate depends on the type of charger used.



(Charger for Ni-Cad Battery)

The Kyosho's Ni-Cad Battery is of high performance. If it is charged correctly, it will operate for a considerable period of time. There are two ways of charging the battery; one is to charge it with a 15hour charger powered from a household 100V outlet, the other is the way through a quick charger powered by a car cigarette lighter or a 12V car battery. Use one of the chargers listed below which suits your need.

Model	Name	Charging Time	Charging rate	Features
No. 2221	Super Ni-Cad Charger (AC100V)	14 to 16 hrs.	100%	For beginners
No. 2326	7.2V Power Charger (DC12V)	15 minutes	about 70%	For beginners timer built in
No. 1846	Multi Charger (DC12V)	20 minutes	100%	Timer, Ammeter built in
No. 1845	Lambda Rapid Charger (DC12V)	about 20 minutes	100%	Trickle charging. Automatic Cut-off at peak of charge
No. 2232	Super Ni-Cad AC Rapid Charger	about 40 minutes	about 80%	Chargable from Household Outlet, Electronic Timer built in

(Motor)

Six (6) types of Racing Motor "Le Mans" are available which are suitable.

- *Spa 240WS
- *Le Mans Sports H-240S
- *Le Mans 360 Gold
- *Le Mans 240S
- *Le Mans 240SB
- *Le Mans 360PT

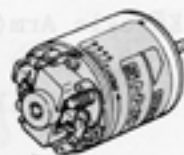

TOOLS REQUIRED

A 1.5mm allen wrench and grease are included in the kit.

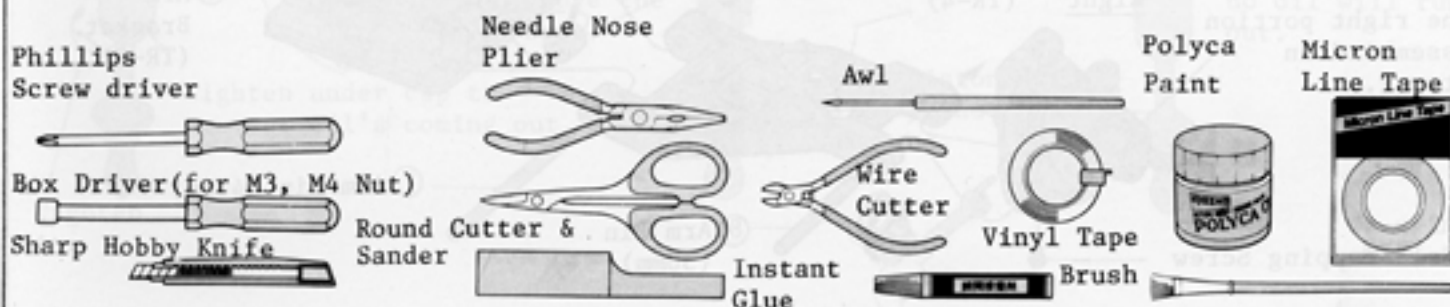

1 ASSEMBLY OF FRONT GEARBOX

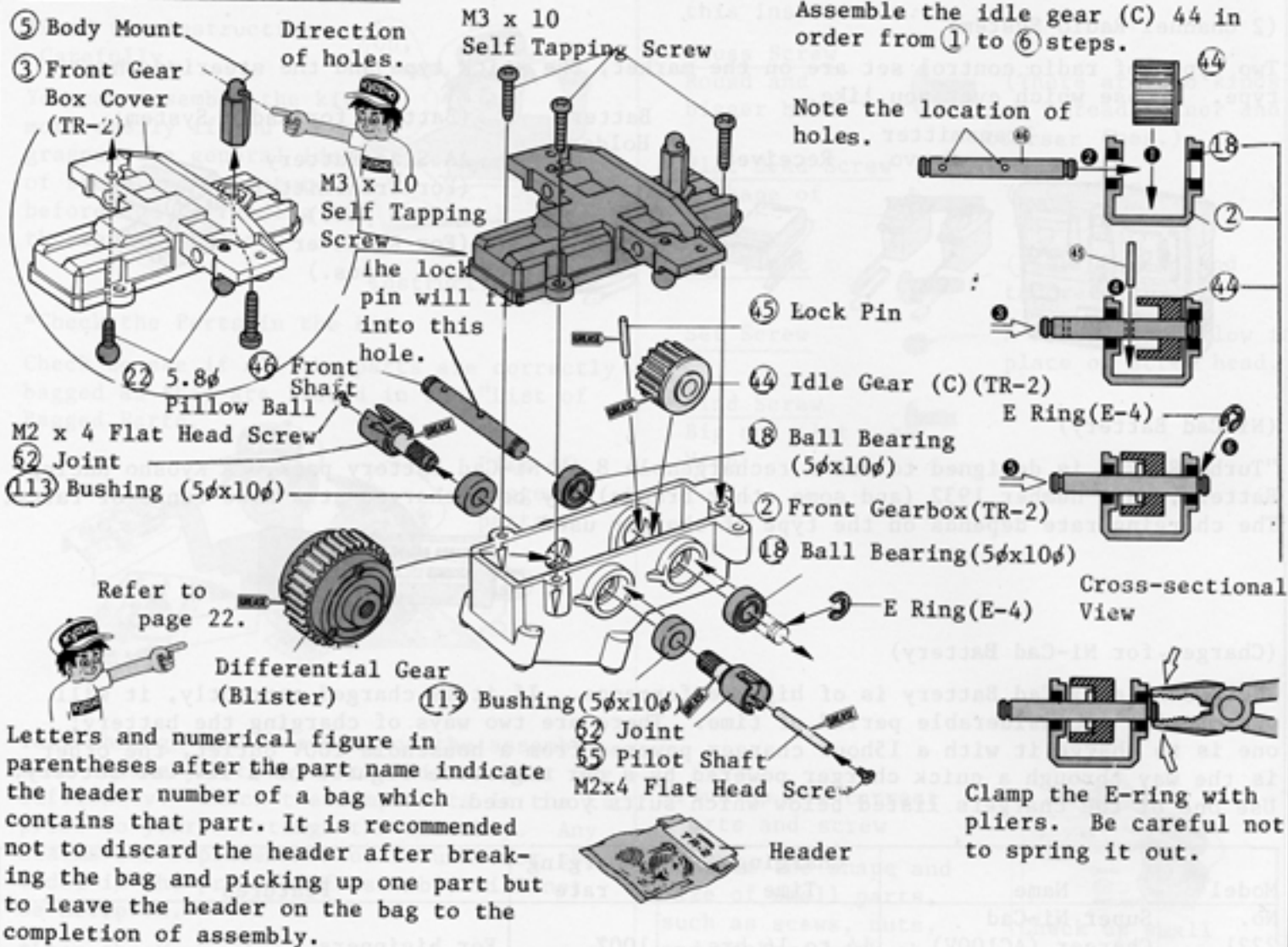

Letters and numerical figure in parentheses after the part name indicate the header number of a bag which contains that part. It is recommended not to discard the header after breaking the bag and picking up one part but to leave the header on the bag to the completion of assembly.

2 INSTALLATION OF KNUCKLE ARM

*Assemble left portion in the same way.

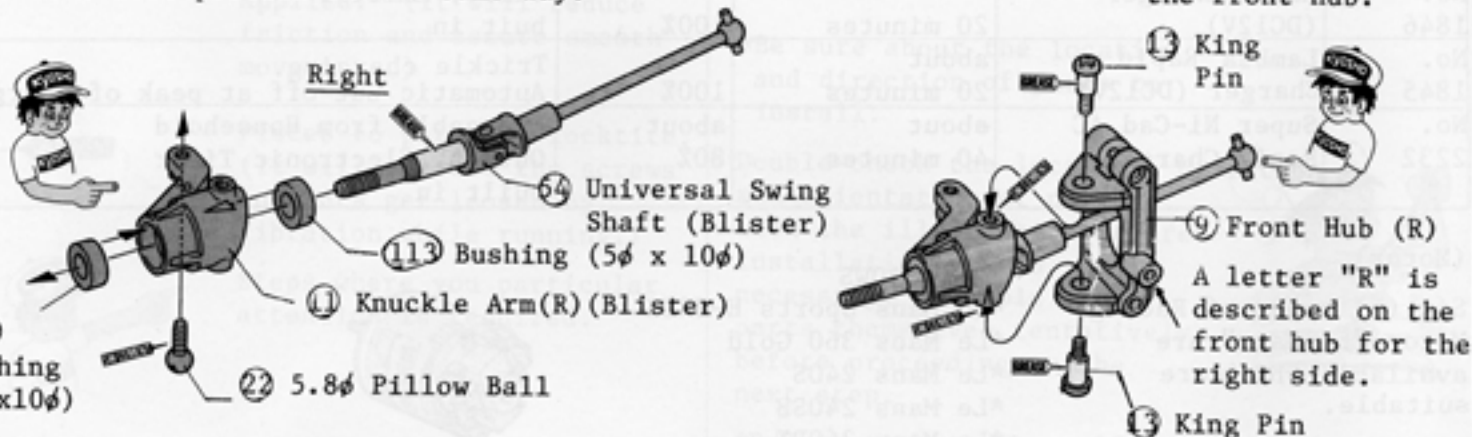

3 ASSEMBLY OF FRONT SUSPENSION

Assembly of left portion in the same way.

The right portion assembled in step 2.

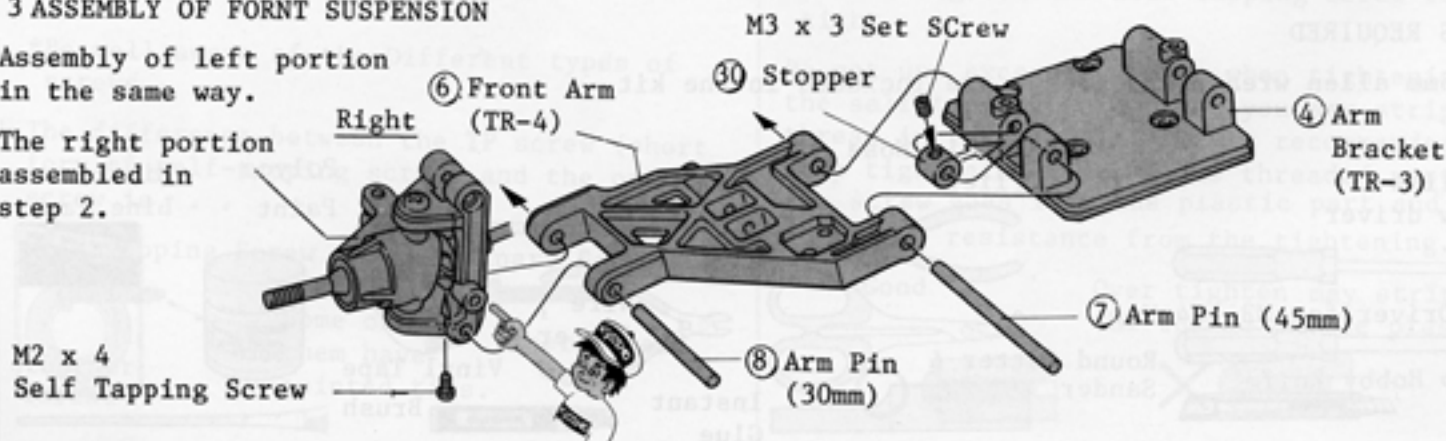

4 ASSEMBLY OF FRONT PORTION

(Fixing the upper rod)
Assemble two of these on
the right & left.

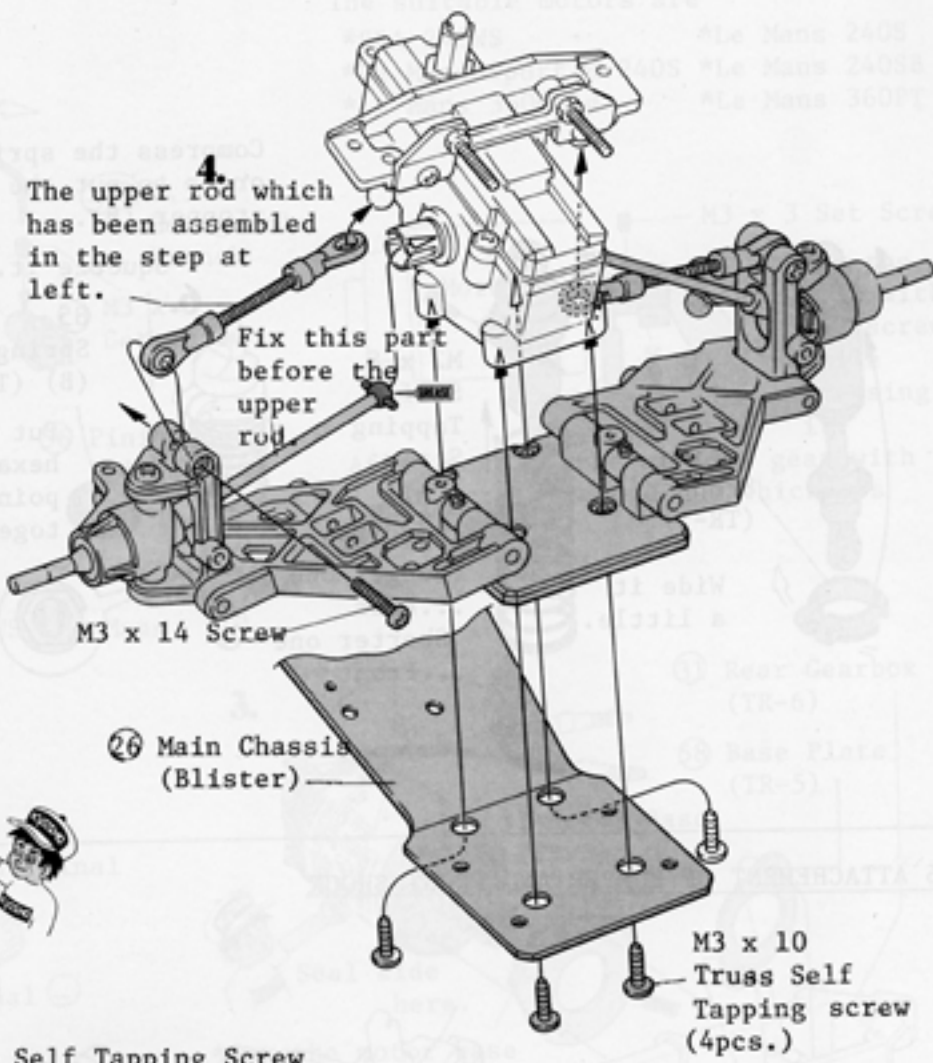
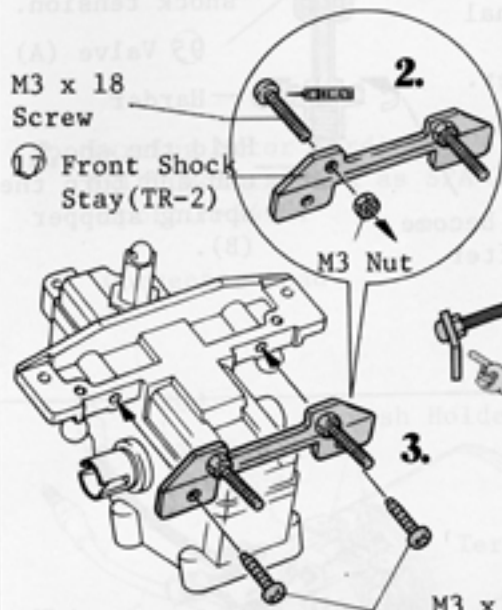
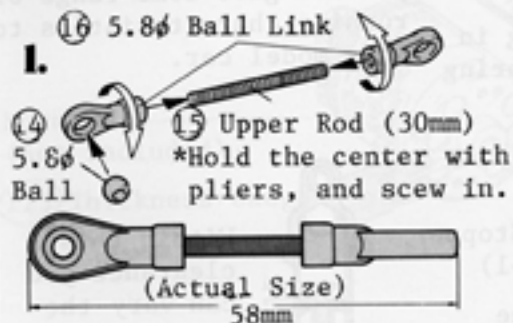

5 ASSEMBLY OF OIL SHOCK

*Disassemble the oil shock, which has been fixed temporarily, and pour oil.
*Do not mistake the front ones from the rear ones; they use a few different parts.

1. Disassemble them in order as illustrated.
2. Push the piston all the way down and pour the oil little by little.
3. Keep the piston at the bottom and screw in the top cap gently, then any excessive oil will flow out.

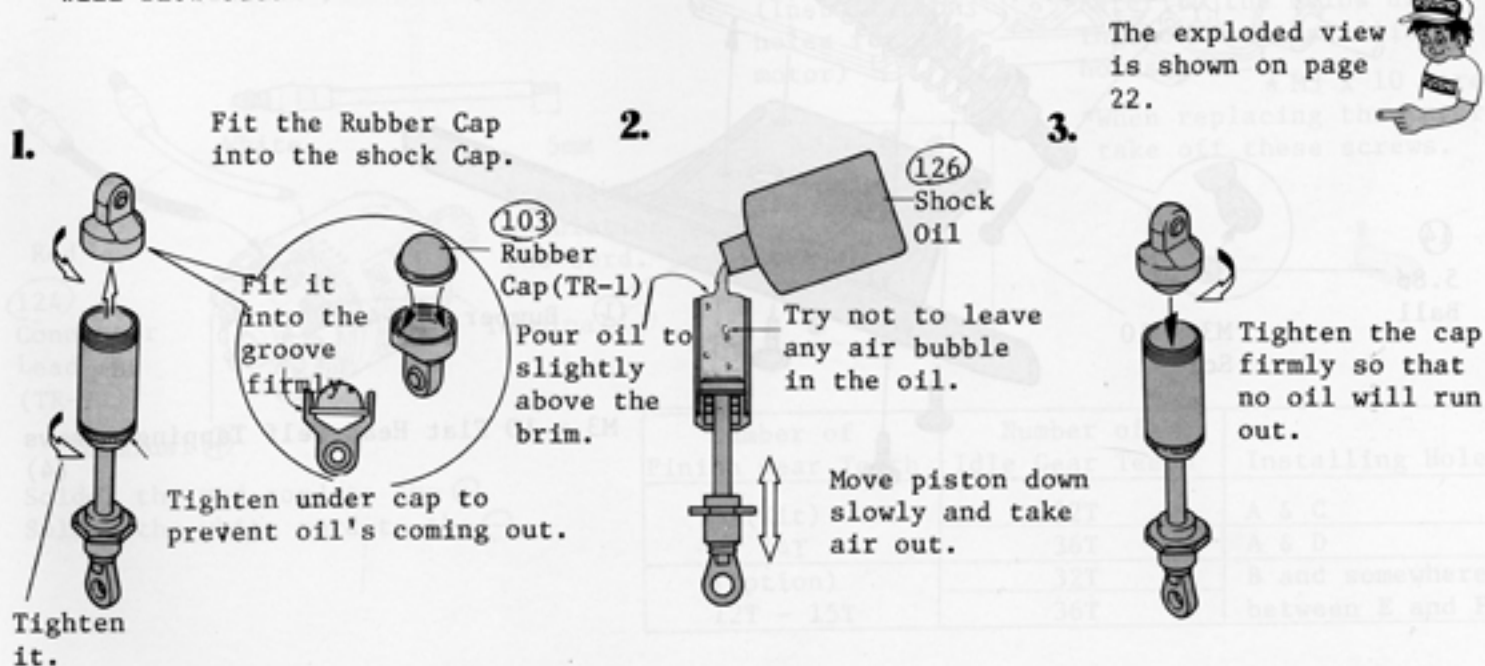

(Adjustment of Shock Absorbing Power)
 Be diversifying the effectiveness of the shock, you can give some range of running characteristics to your model car.

Compress the spring in order to put the spring stopper (B).

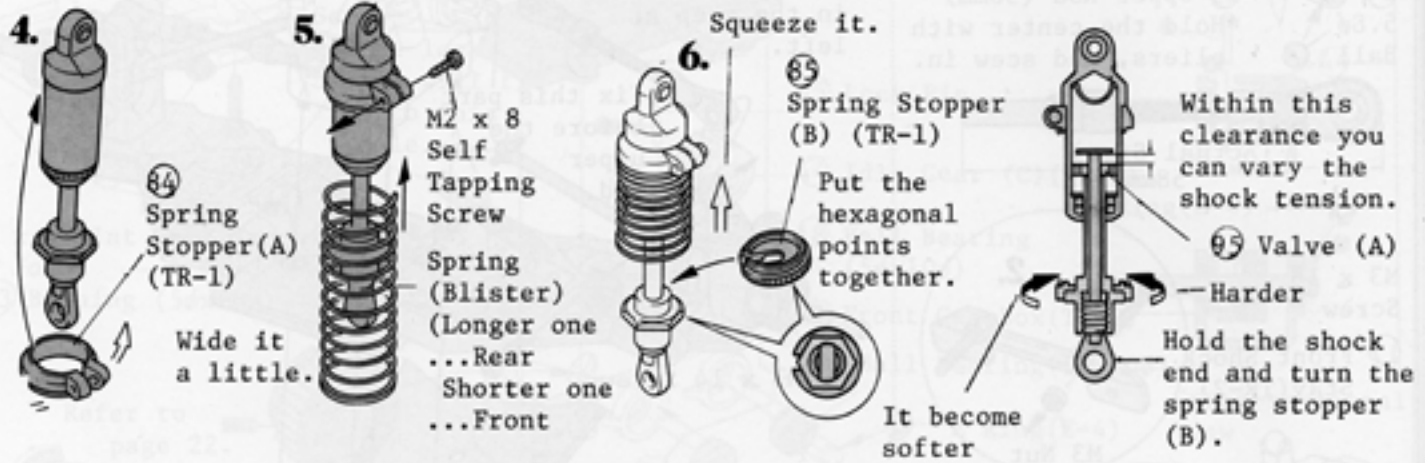

6 ATTACHEMENT OF BUMPER AND FRONT SHOCK

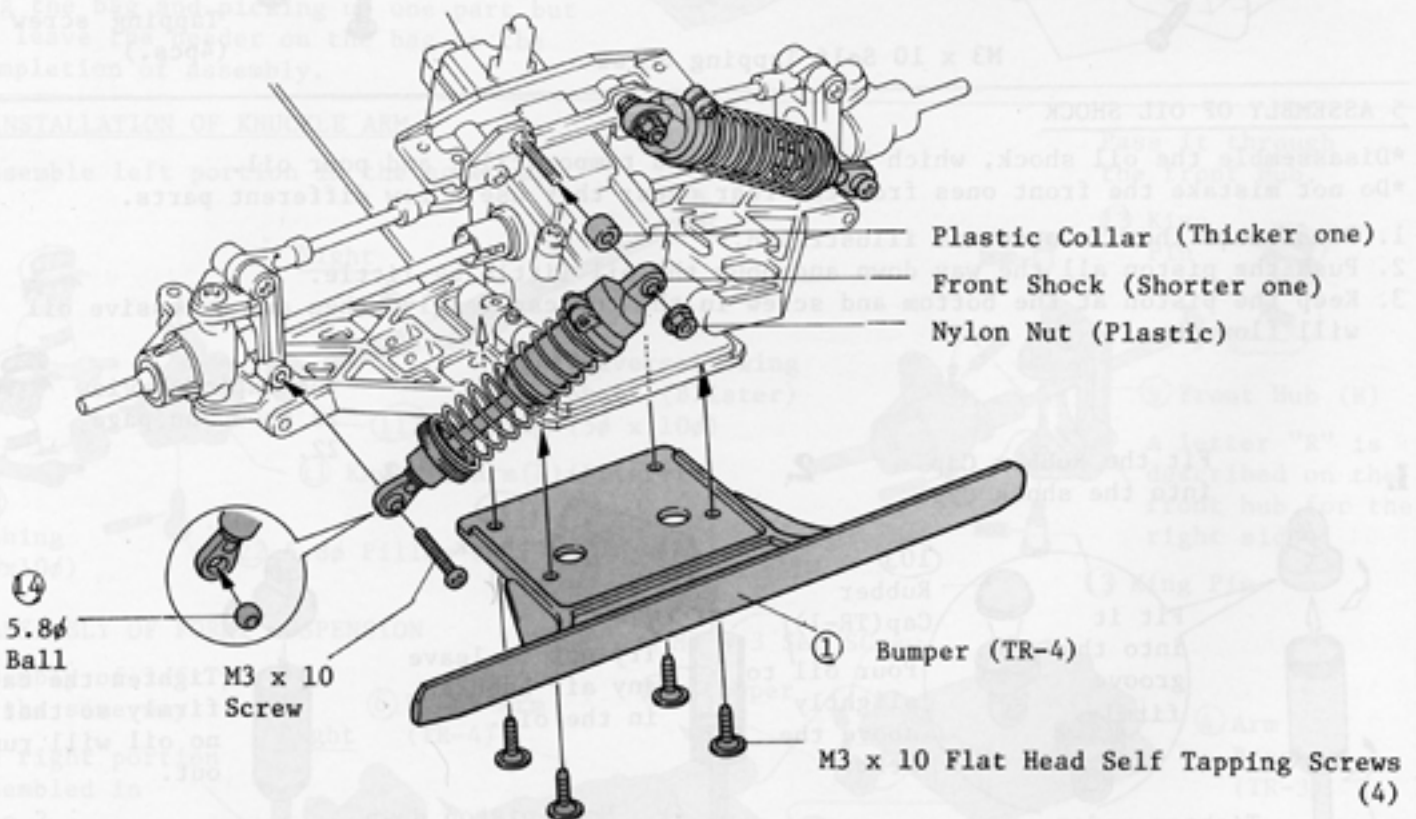

7 MOUNTING OF MOTOR

1. (Installation of Pinion Gear)

*Motor is not included in the kit.
The suitable motors are

- *SPA 240WS
- *Le Mans 240S
- *Le Mans Sport H-240S
- *Le Mans 240SB
- *Le Mans 360Gold
- *Le Mans 360PT

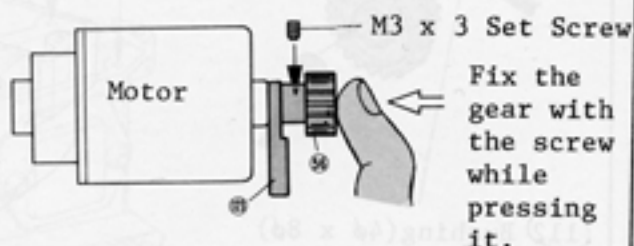
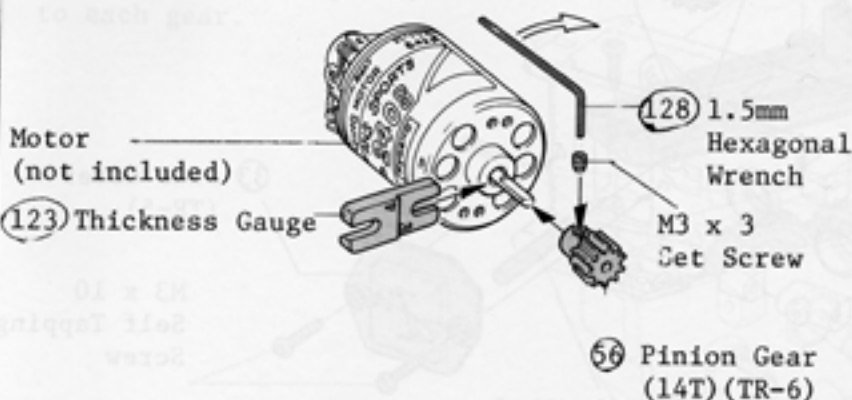

After setting the pinion gear with a set screw, remove the thickness gauge (123)

2. (wiring Motor Cord)

*With motors such as SPA 240WS, Le Mans Sport H-240S.

Connector Lead

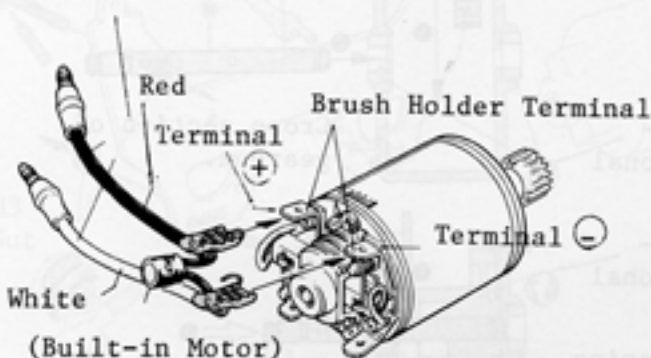

3.

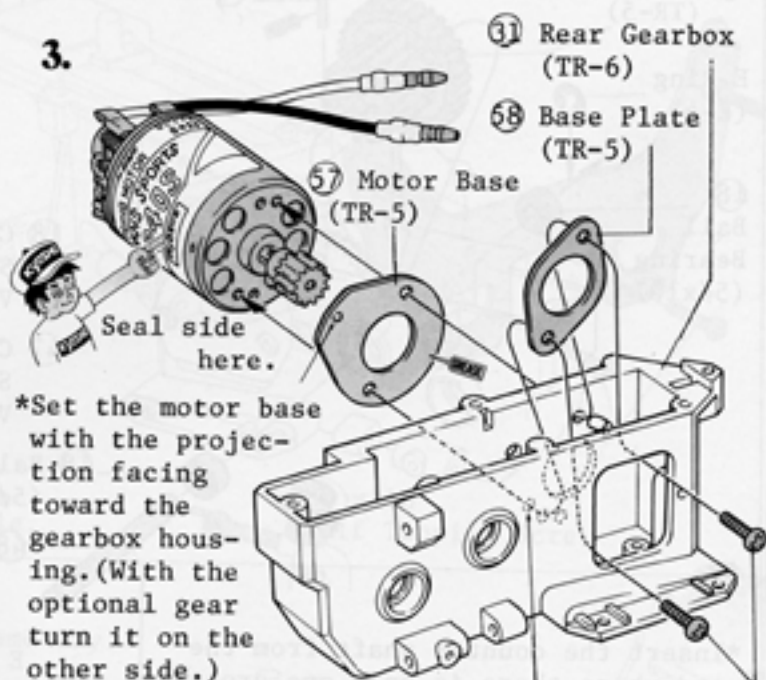

*Set the motor base with the projection facing toward the gearbox housing. (With the optional gear turn it on the other side.)

(Installation holes for the motor)

*Refer to the below drawing for the installing holes.

* M3 x 10 Screw

*When replacing the motor, take off these screws.



*With Le Mans 240S, 240SB, 360PT & 360 Gold.

Cut the motor cord as shown below and solder it to the motor.

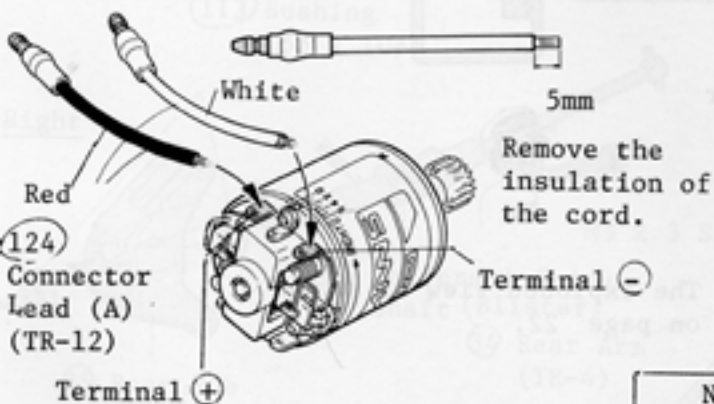

Solder the red cord to the ⊕
Solder the white cord to the ⊖

Number of Pinion Gear Teeth	Number of Idle Gear Teeth	Installing Holes
(Kit)	32T	A & C
14T	36T	A & D
(Option)	32T	B and somewhere between E and F
12T - 15T	36T	

8 ASSEMBLY OF REAR GEARBOX (1)

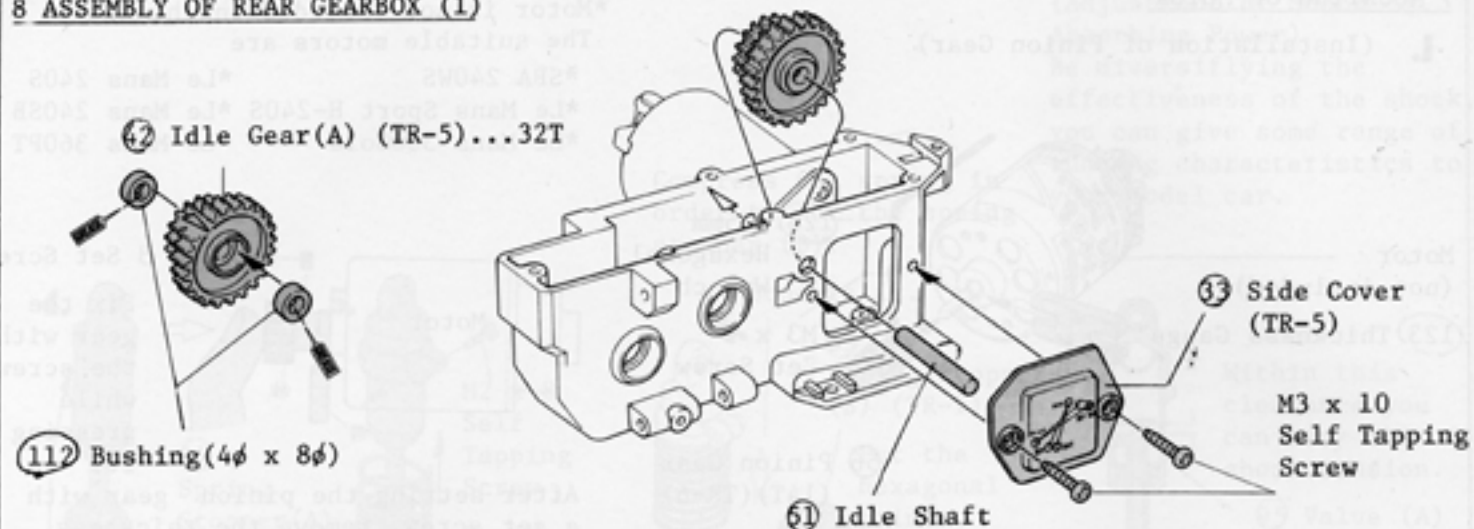

9 ASSEMBLY OF REAR GEARBOX (2)

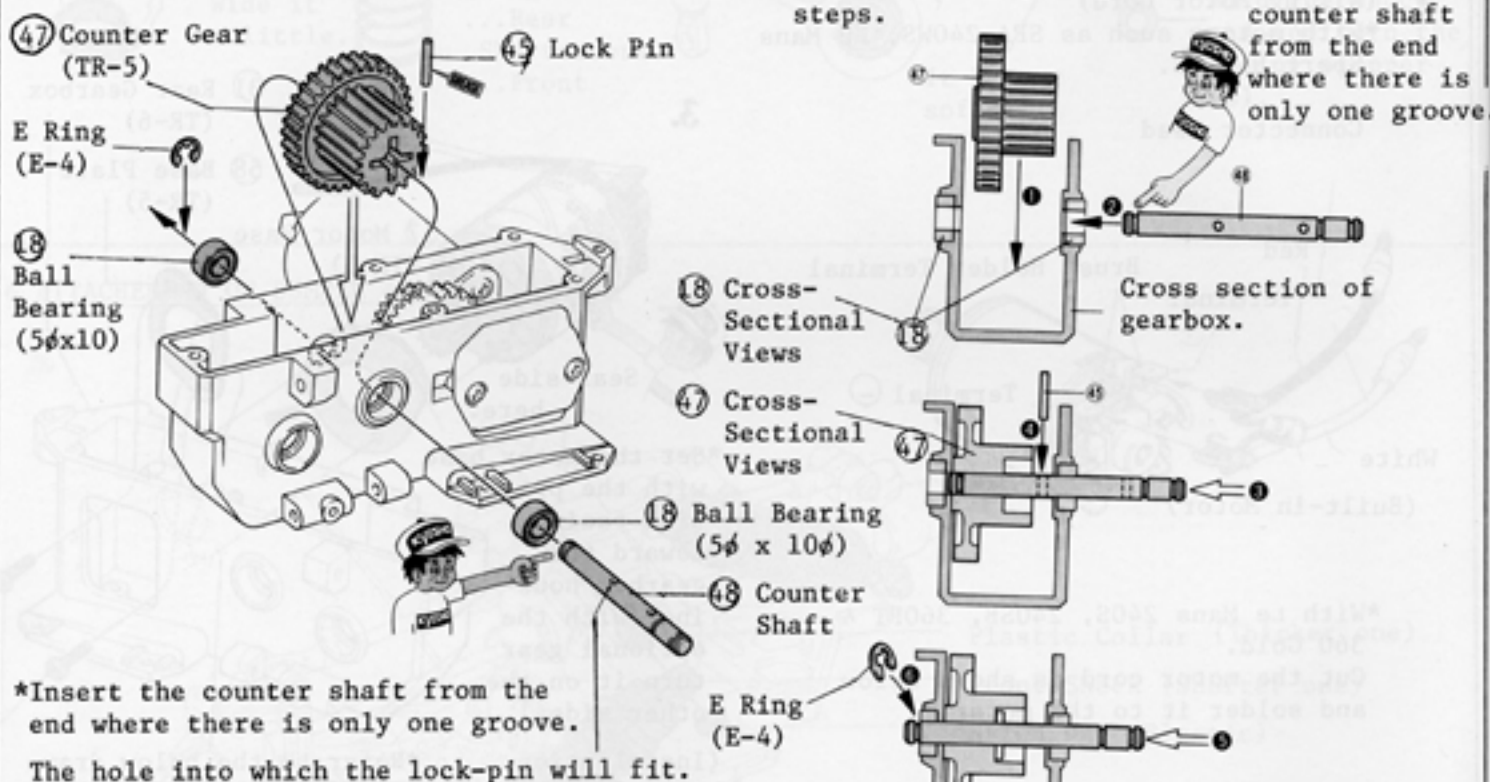

10 ASSEMBLY OF REAR GEARBOX (3)

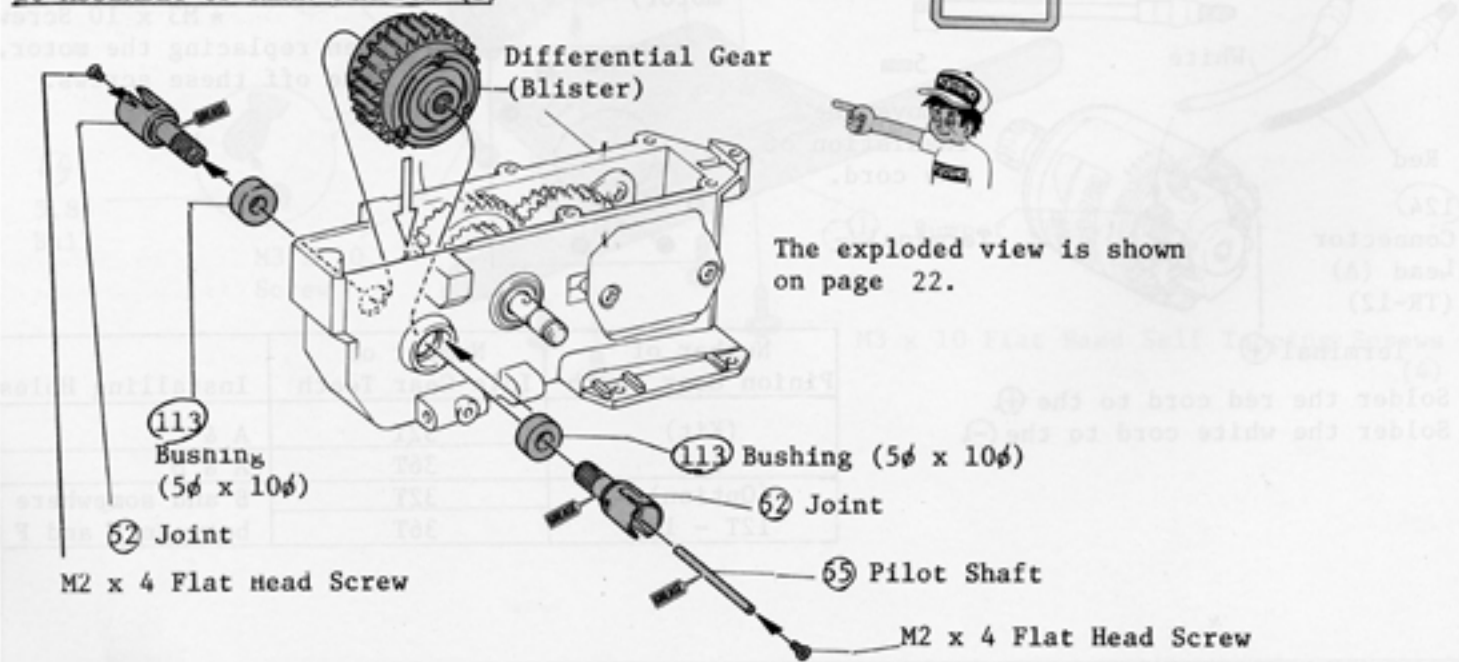

11 FIXING OF GEARBOX COVER

*Apply screw locking compound to each gear.

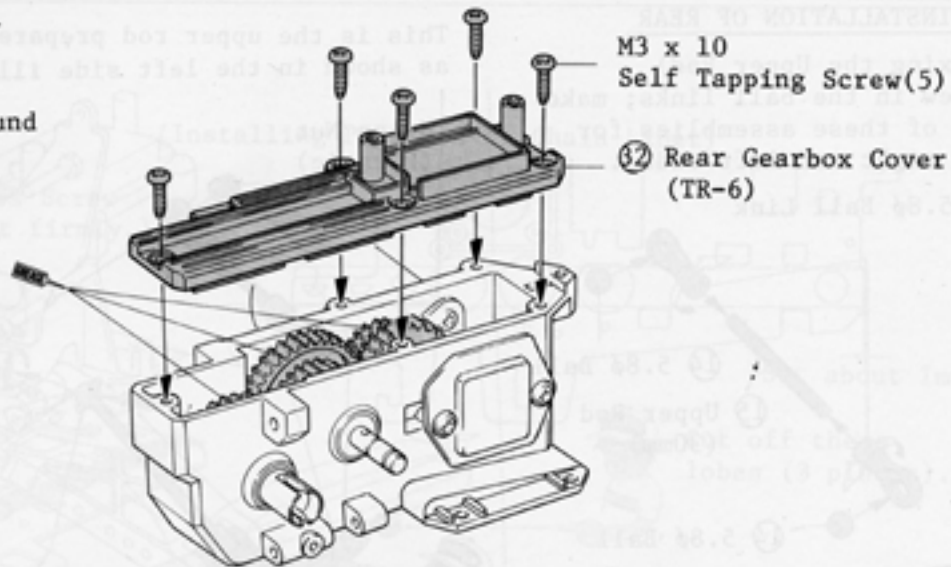

12 INSTALLATION OF REAR SHOCK STAY

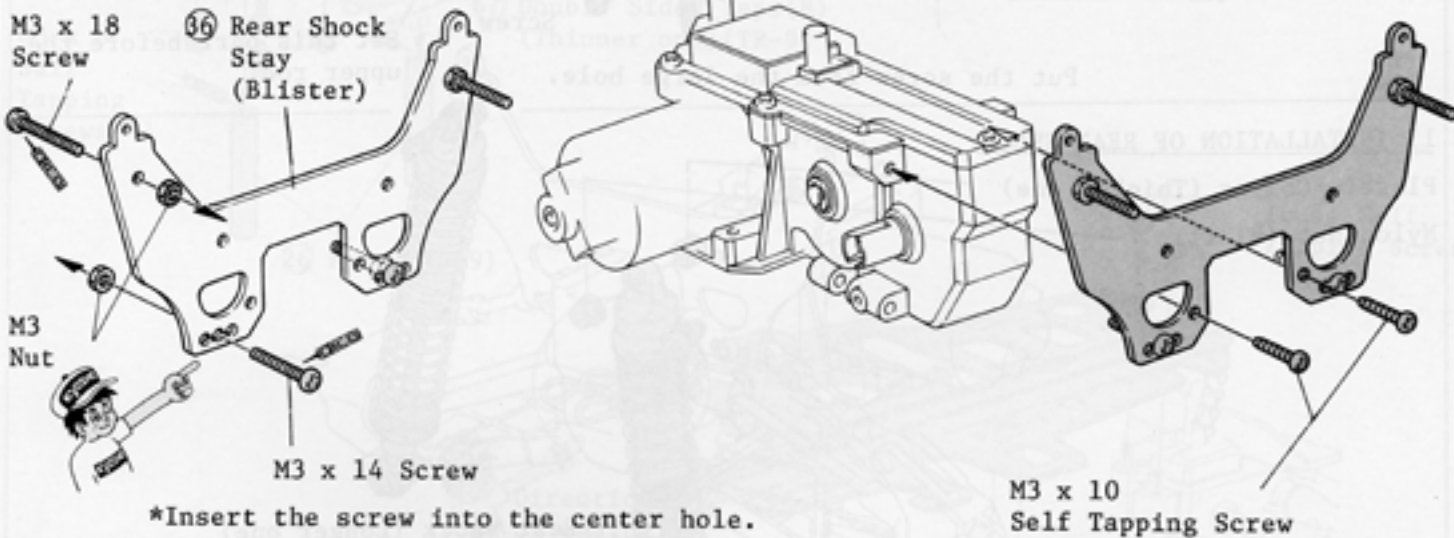

13 ASSEMBLY OF REAR SUSPENSION

*Assemble the right and left portion in the same way.

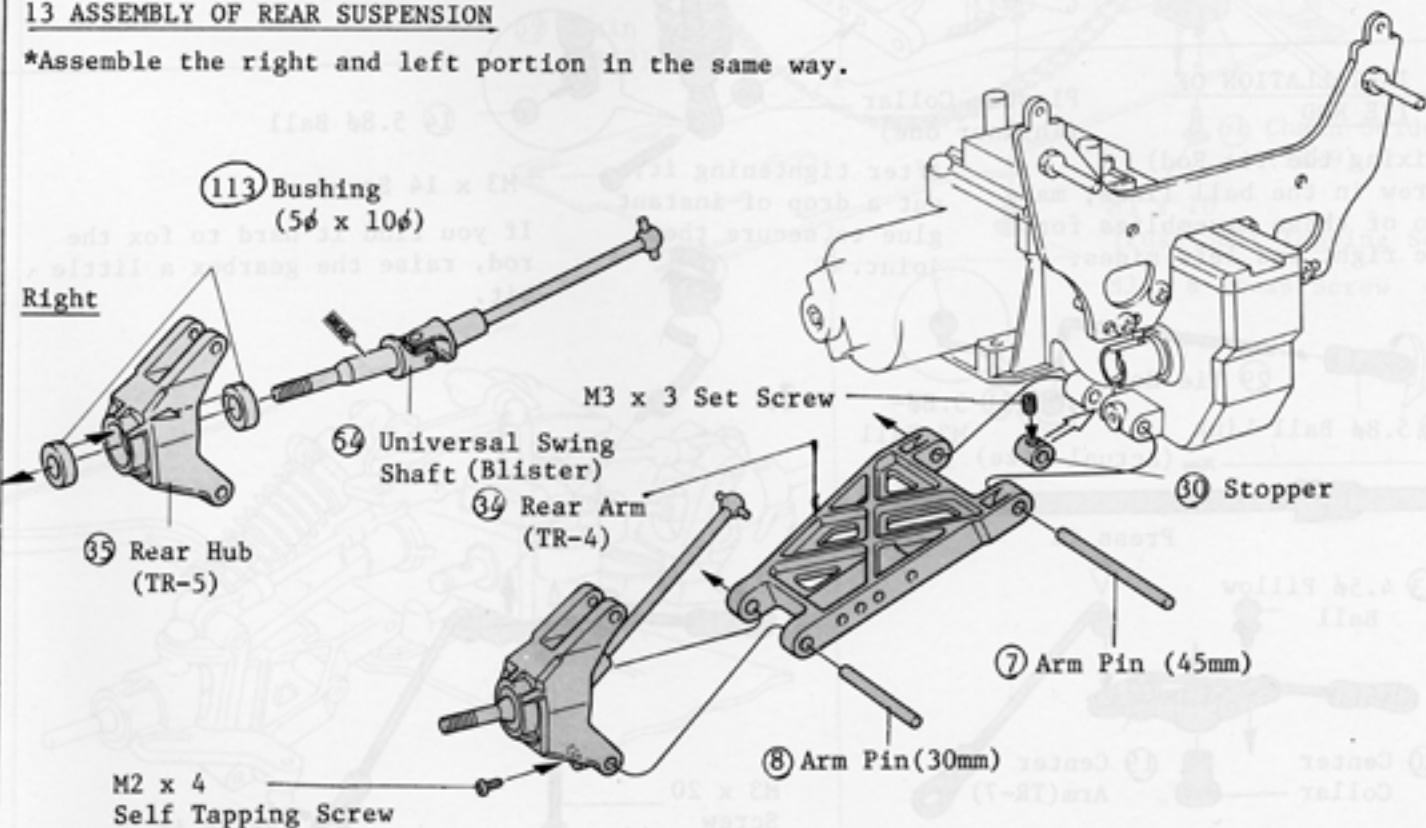

14 INSTALLATION OF REAR

(Fixing the Upper Rod)

Screw in the ball links; make two of these assemblies for the right and left sides.

⑬ 5.8φ Ball Link

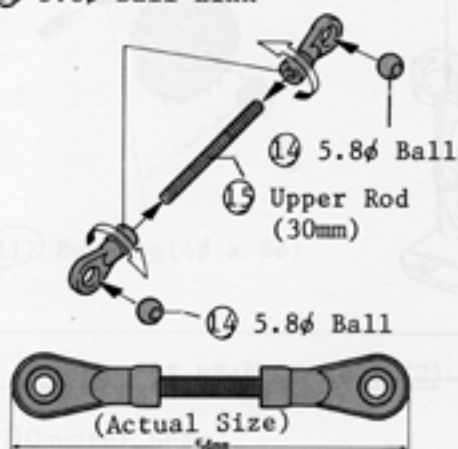

This is the upper rod prepared in the step as shown in the left side illustration.

Nylon Nut (Plastic)

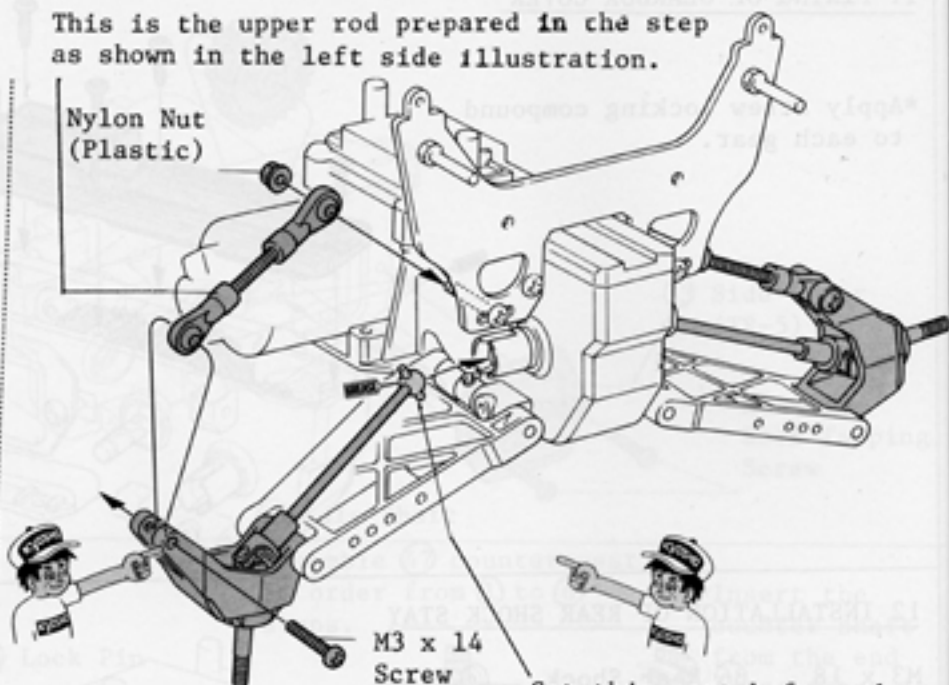

Put the screw from the large hole.

Set this part before the upper rod.

15 INSTALLATION OF REAR SHOCK

Plastic Collar (Thicker one)

Nylon Nut (Plastic)

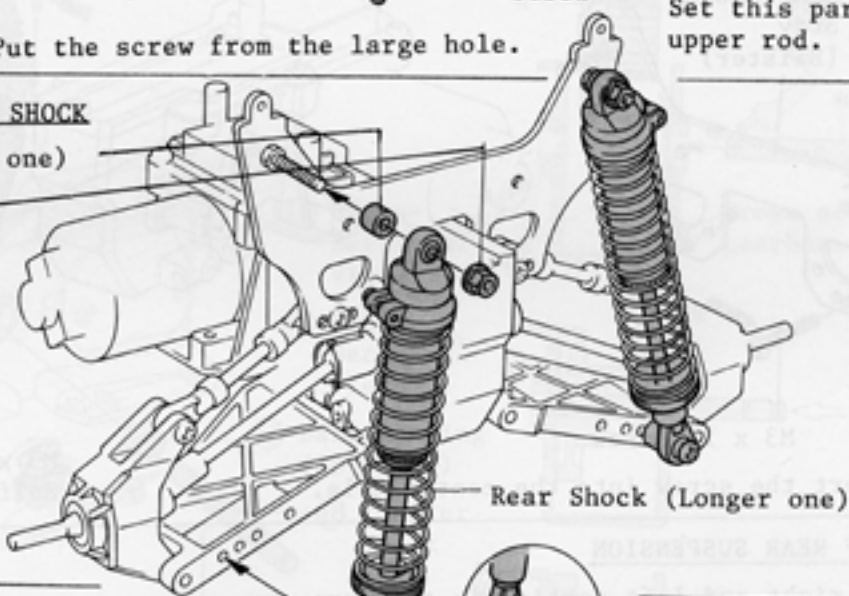

16 INSTALLATION OF TIE ROD

(Fixing the Tie Rod)

Screw in the ball links; make two of these assemblies for the right and left sides.

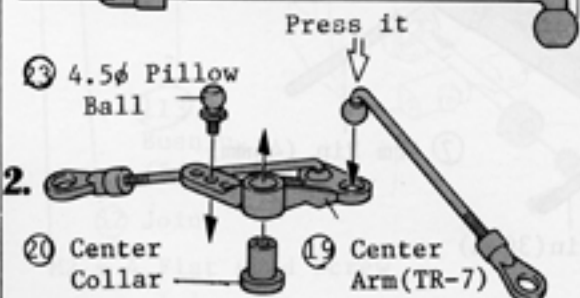
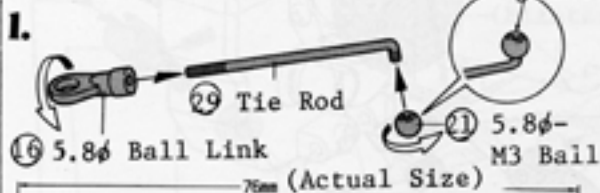

Plastic Collar (Thinner one)

After tightening it, put a drop of instant glue to secure the joint.

⑭ 5.8φ Ball

M3 x 14 Screw

If you find it hard to fix the rod, raise the gearbox a little bit.

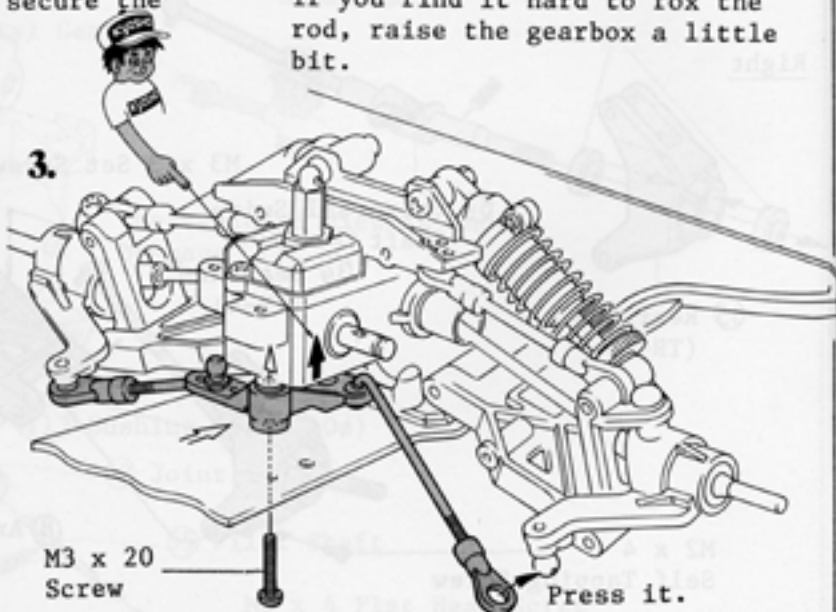

(Installing Position of Chain Liner)

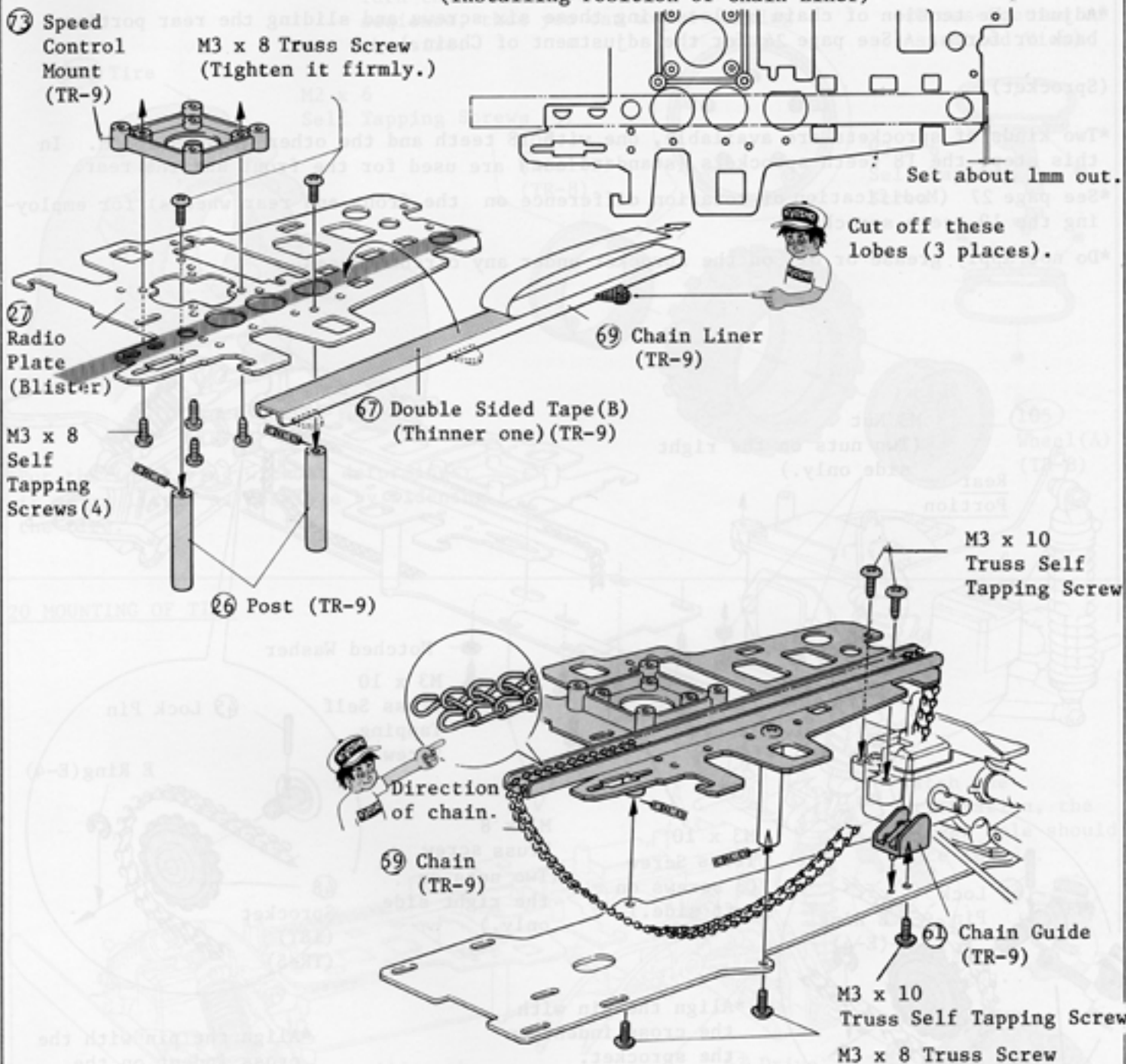

18 INSTALLATION OF REAR PORTION

(Adjust the Tension of Chain)

*Adjust the tension of chain by loosening these six screws and sliding the rear portion back or forth. (See page 24 for the adjustment of Chain.)

(Sprocket)

*Two kinds of sprockets are available, one with 18 teeth and the other with 19 teeth. In this step, the 18 teeth sprockets (standard one) are used for the front and the rear.

*See page 27 (Modification of rotation difference on the front and rear wheels) for employing the 19 teeth sprocket.

*Do not apply grease or oil on the sprocket under any circumstances.

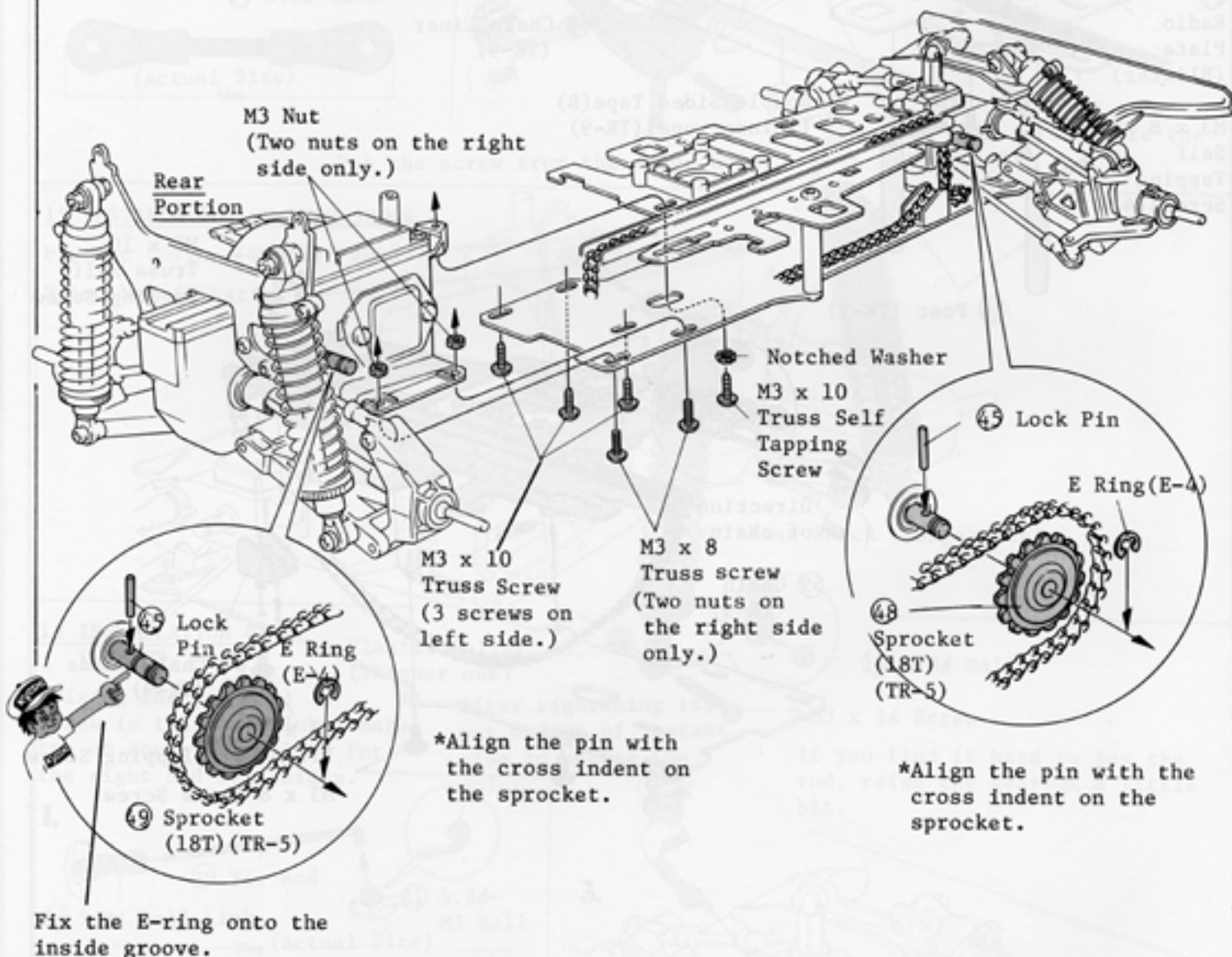

(Tightening of Fixing Screws)

Turn the screws from 1 to 5 in good sequence, then you can avoid warping the tire.

(Cross-Section of Assembled View)

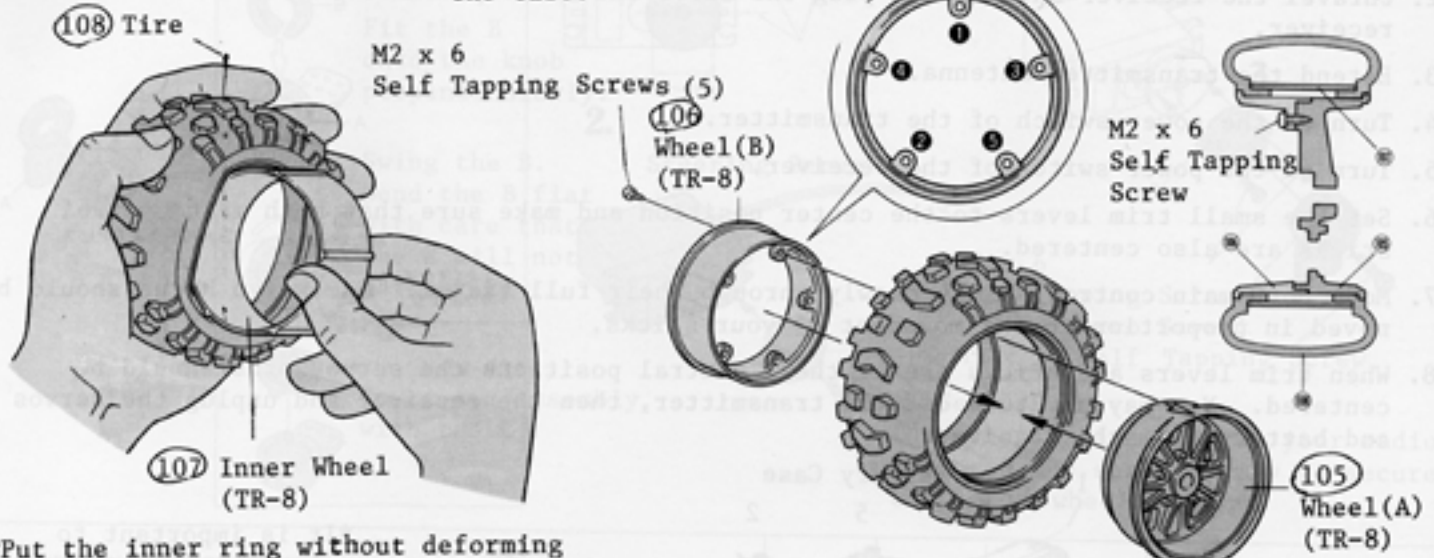

*Put the inner ring without deforming it or as little as possible by widening the tire.

20 MOUNTING OF TIRE

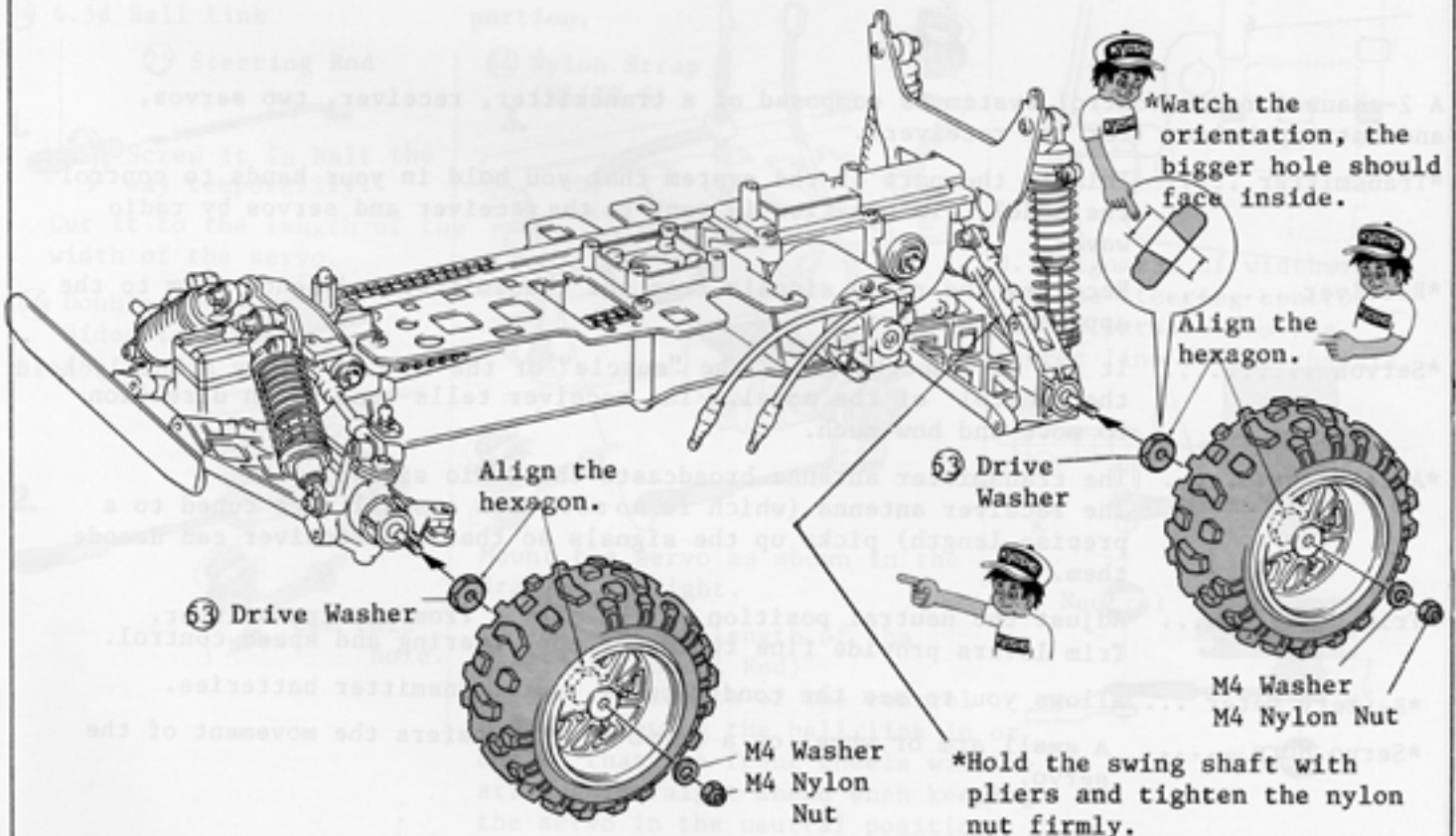

21 HOW TO CHECK RADIO SYSTEM

Follow steps 1-8.

1. Install the batteries into both the transmitter and receiver. If your radio is a rechargeable system, charge it as outlined in the manual that came with your set.
2. Unravel the receiver antenna and plug the servo and battery connectors into the receiver.
3. Extend the transmitter antenna.
4. Turn on the power switch of the transmitter.
5. Turn on the power switch of the receiver.
6. Set the small trim levers to the center position and make sure that both main control sticks are also centered.
7. Move both main control sticks slowly through their full travel. The servo horns should be moved in proportion to the movement of your sticks.
8. When trim levers and sticks are at their neutral positions the servo horns should be centered. You may now turn off the transmitter, then the receiver and unplug the servos and battery from the receiver.

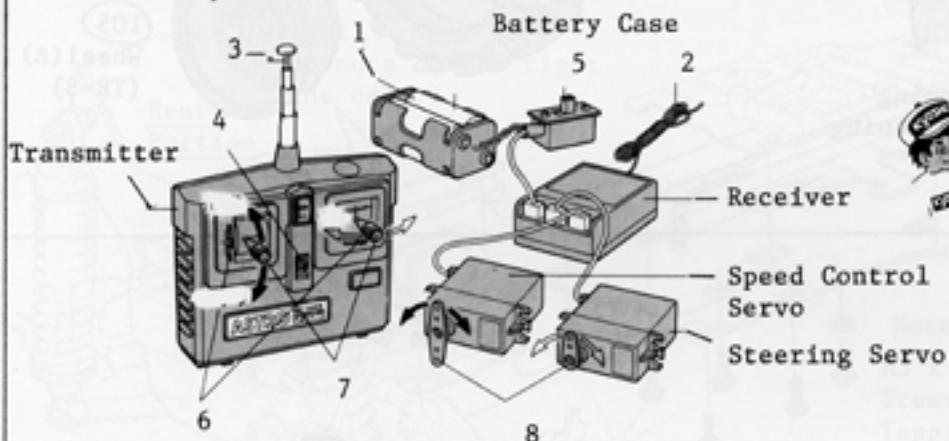

*It is important to always switch the transmitter on first... then the receiver. When turning off the system, turn off the receiver first and then transmitter.

A 2-channel radio control system is composed of a transmitter, receiver, two servos, and battery holder (for the receiver).

- *Transmitter This is the part of the system that you hold in your hands to control the model. Information is sent to the receiver and servos by radio waves.
- *Receiver Receives the radio signals from the transmitter and sends them to the appropriate servo.
- *Servos It can be thought of as the "muscle" of the system. They actually hold the control of the model. The receiver tells them which direction to move and how much.
- *Antenna The transmitter antenna broadcasts the radio signal. The receiver antenna (which is no more than a small wire tuned to a precise length) picks up the signals so that the receiver can decode them.
- *Trim Levers Adjust the neutral position of the servos from the transmitter. Trim levers provide fine tuning of the steering and speed control.
- *Battery Meter ... Allows you to see the condition of your transmitter batteries.
- *Servo Horn A small arm or wheel on a servo that transfers the movement of the servo.

22 MOUNTING OF SERVO SAVER

*The servo saver parts (A to D) are contained in (TR-9).

Use servo horn which has holes 13-16mm apart.

Set the servo horn in such a way that the holes are parallel to the servo sides, when the transmitter control stick and the trim lever are positioned in neutral.

1. The way of assembling the Servo Saver.

Fit the B onto the knob perpendicularly.

Knob

Swing the B. Bend the B flat with care that the B will not get out of place.

Cover the assembly with the C.

2. Steering Servo

3. Servo Horn

M2 x 6 Self Tapping Screw

M3 x 10 Self Tapping Screw

The screw is included in your radio. (Tighten the screw firmly to secure the servo wheel.)

23 MOUNTING OF STEERING SERVO

(Mounting Point of Servo) Follow the steps A and B.

A. Alignment of lengthwise: Set the centers of the square holes with that of the servo.

B. Alignment of widthwise: Set the steering control rod in parallel to the center line of the chassis.

24 4.5φ Ball Link

25 Steering Rod

1. Screw it in half the way temporarily. Cut it to the length of the width of the servo.

66 Double Sided Tape (A) (TR-9)

2. Use this hole.

After fastening it, cut off the excess portion.

Lead out servo cord.

64 Nylon Strap (M) (TR-9)

3.

Mount the servo as shown in the drawing at right.

(Adjustment of length of the Steering Control Rod)
Adjust the length of the control rod by screwing the ball link in or out so that the front wheels will be arranged straight ahead when keeping the servo in the neutral position.



You will shorten the length of the rod by turning it right.

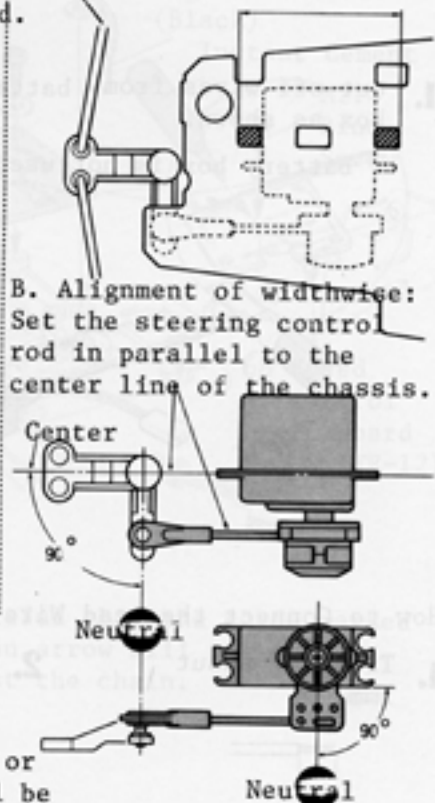

24 INSTALLATION OF SPEED CONTROL SERVO

This servo should be mounted as shown here.

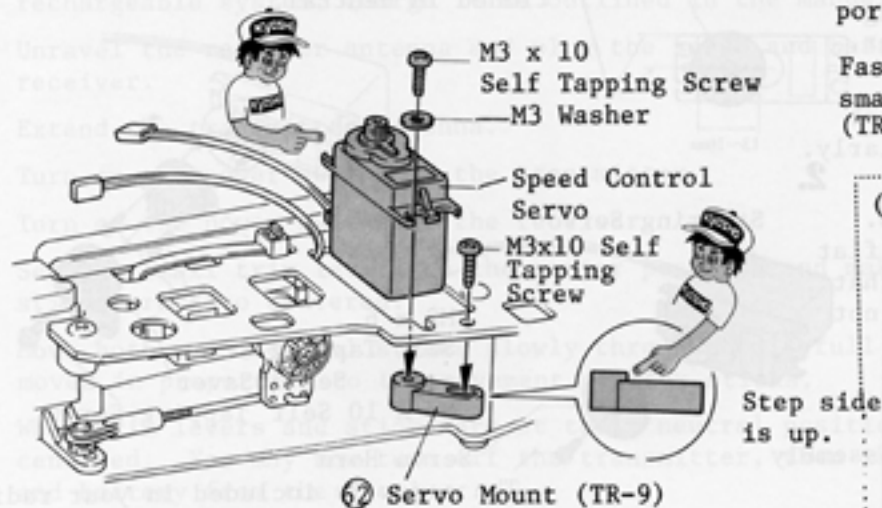

After fastening it, cut off the excess portion.

Fasten it with a small strap ⑥5. (TR-9)

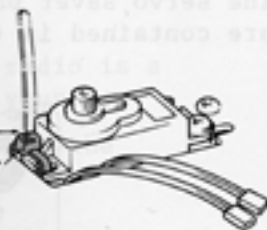

(With a Large Servo)

Secure it on both sides with small straps ⑥5.



25 WIRING OF RECEIVER BATTERY

The battery that powers the motor also powers the receiver. Use great care and do not allow polarity to be reversed. Also, do not allow 8.4V to flow directly into receiver.

The colors of the lead wires are different depending upon radio manufacturer. Most use red wire positive (+) and black for negative (-). The exception being Cox and Airtronics (Sanwa). Their (+) lead has a white stripe and the middle lead is (-).



1. Cut off wires from battery box as shown.

Battery box is not used.

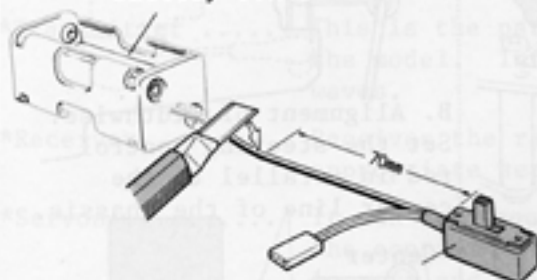

2. Connect the leads from the R/C unit switch and the regulator.

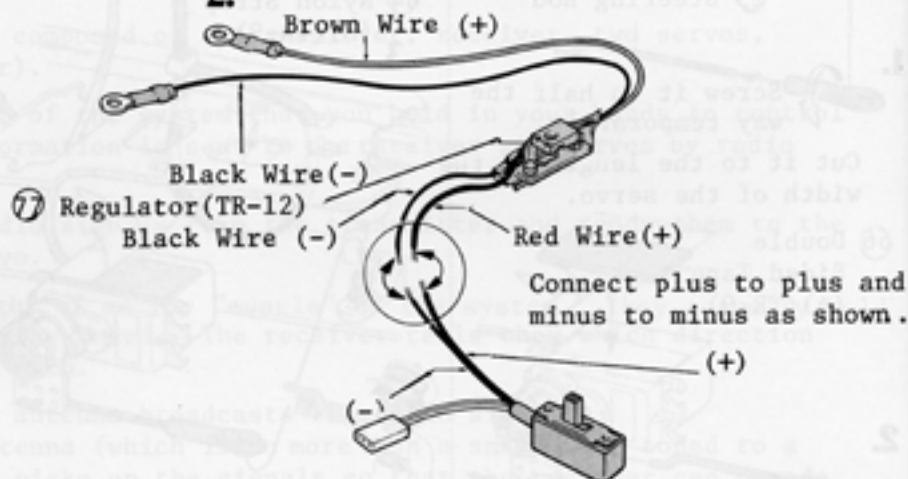

(How to Connect the Lead Wire)

1. Trim off about 5mm.



2. Splice and connect the cords of the same polarity.



For ensuring the job, solder the spliced leads.

3. Insulate the connection points with vinyl tape to prevent a short-circuit.



26 INSTALLATION OF SWITCH AND REGULATOR

Use the screw included with your radio.

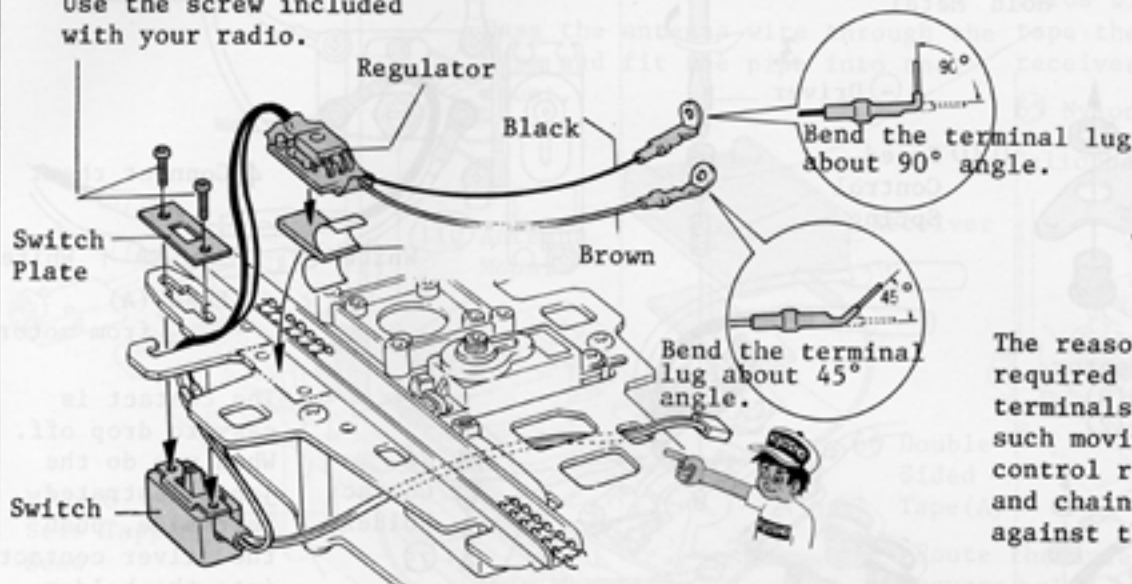

The reason why you are required to bend the terminals is to avoid that such moving parts as the control rod, servo horn, and chain will not rub against the electric cords.

Lead the connector outside through this square hole previously.

27 INSTALLATION OF PC BOARD

*The diode functions as a regulator is to adjust the battery voltage down suitable for the receiver. So avoid, by all means, connecting the battery to the receiver directly.

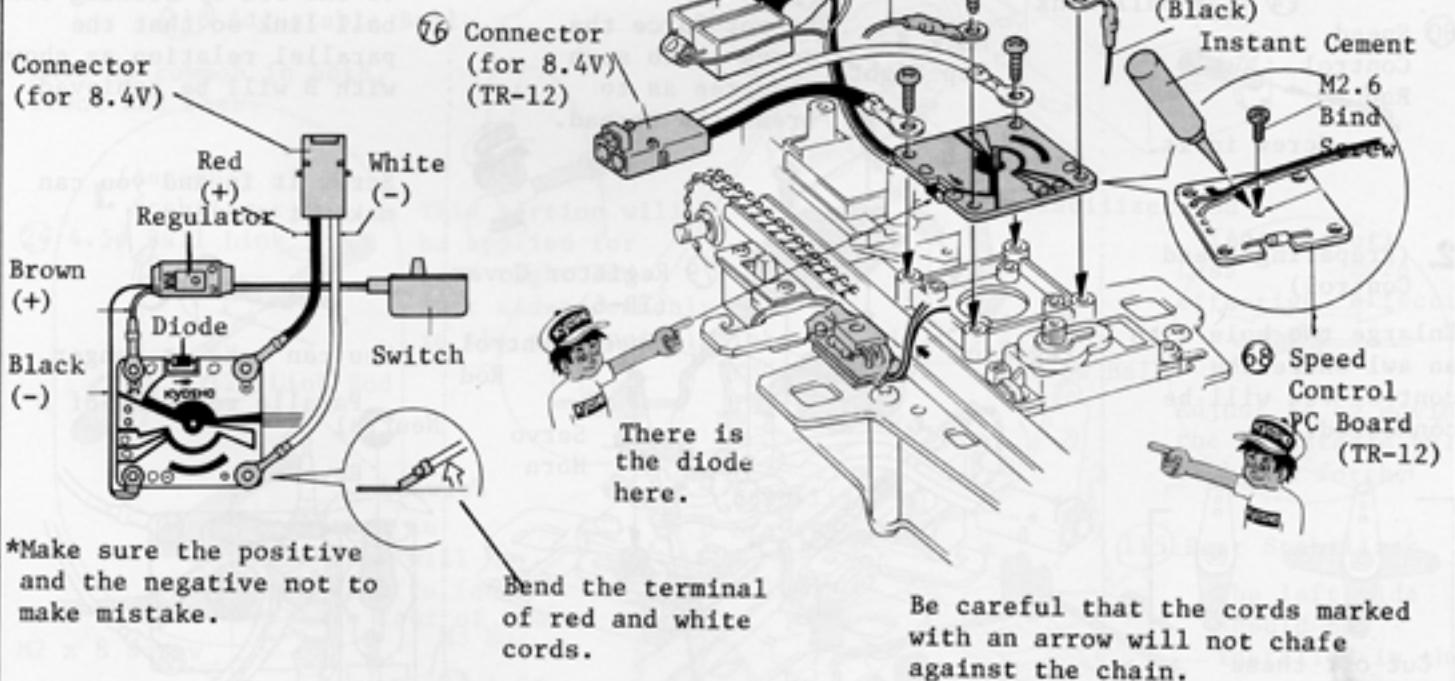

*Make sure the positive and the negative not to make mistake.

28 FIXING OF CONTROL HORN

23 4.5φ Pillow Ball

71 Speed Control Nut

69 Speed Control Horn (TR-10)

M3 Nut

72 Speed Control Pivot

125 Connector Read (B) (TR-12)

2. White (-)

Red (+)

M3 Nut (Gold Color)

75 Contact Holder

Make sure the positive and the negative not to make mistake.

70 Speed Control Hold Metal

131 Speed Control Spring

3.

Driver



There is diode here.

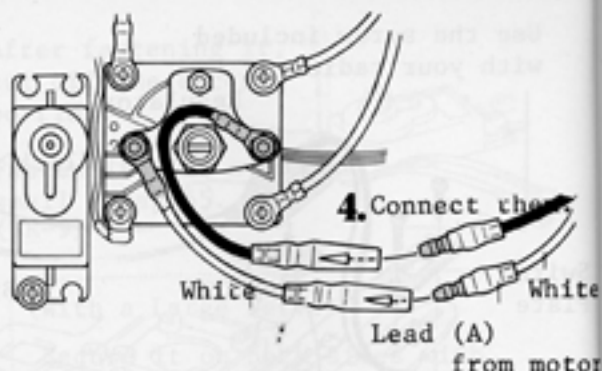

76 Contact Holder

75 Contact point.

*The contact is easy to drop off. When you do the job illustrated left-side, push the silver contact into the holder scrupulously.

29 FIXING OF SPEED CONTROL ROD AND REGISTER COVER

1. (Attaching Ball Link)

24 4.5φ Ball Link

60 Speed Control Rod

Screw in it.

M3 x 8 Tap Tight

Do not force the screw in to such a degree as to break the thread.

2. (Preparing Speed Control)

Enlarge the hole with an awl where the control rod will be connected.



Cut off these portion.

Use a hole which is 12mm away from the center.

3.

Set the register

79 Register Cover (TR-6)

Speed Control Rod

Servo Horn

Screw provided with your radio.

*The speed control servo should operate reversely.

Use a reverse servo or arrange your transmitter in the reverse action, then hook up the servo.

4. (Adjustment of Length of the Rod) Adjust the length of the rod by turning the ball link so that the parallel relation as shown with B will be achieved.

Screw it in and you can make it shorter



You can make it longer.

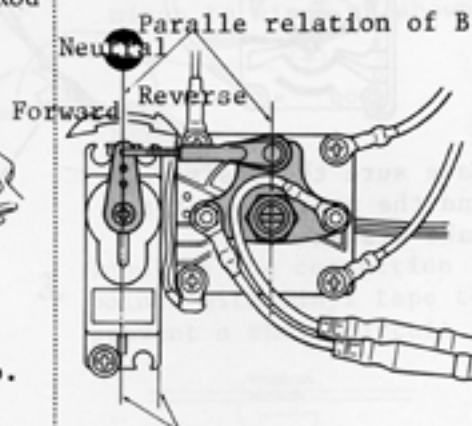

A These lines should be parallel when the servo is held in neutral.

30 INSTALLATION OF RECEIVER AND ANTENNA

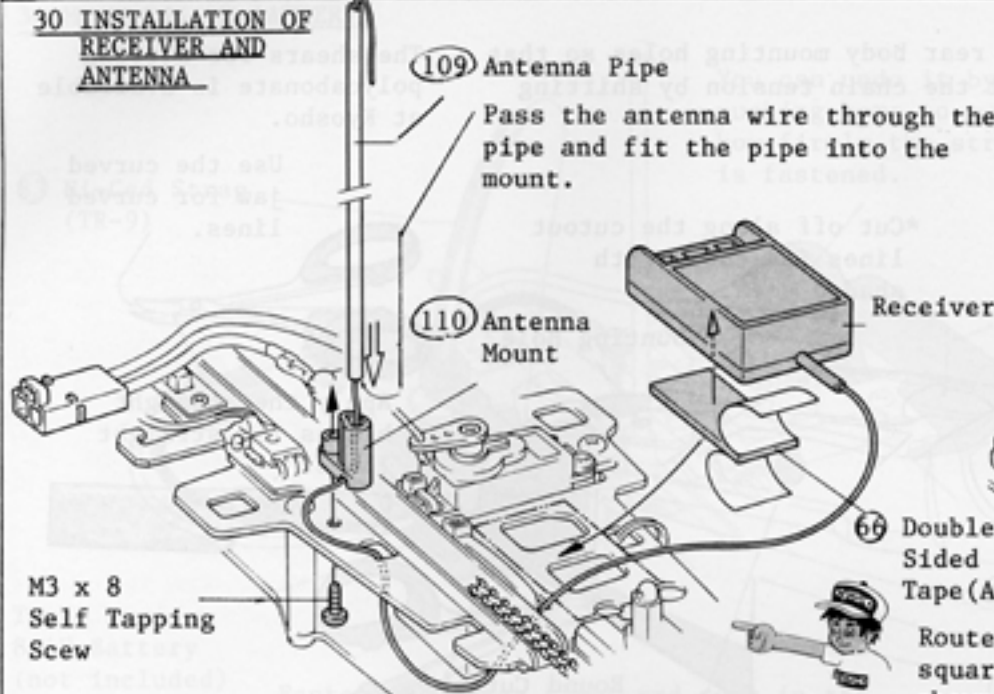

Plug in all connectors into the receiver, bundle the cords with a small strap and tape them down onto the receiver.

- 65 Nylon Strap (S)
- Cellophane Tape

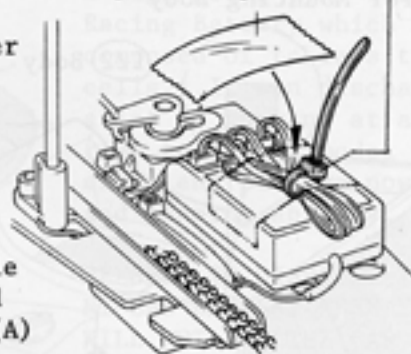

- 66 Double Sided Tape (A)

Route the antenna wire through the square holes on the radio plate as shown.

31 INSTALLATION OF STABILIZER

*All the parts required in this step are packed in the (TR-11) bag.
(Front Stabilizer)

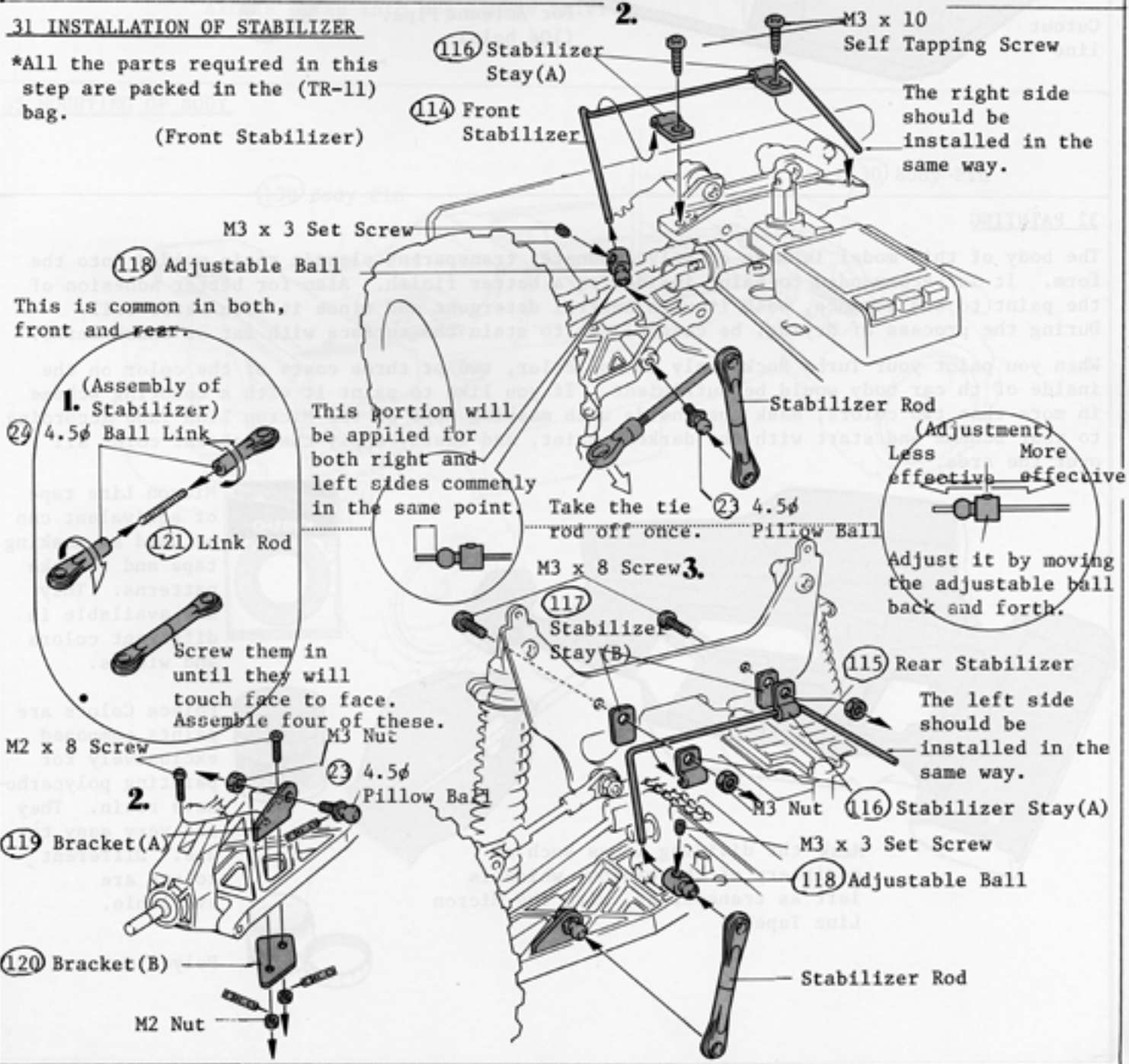

The right side should be installed in the same way.

This is common in both, front and rear.

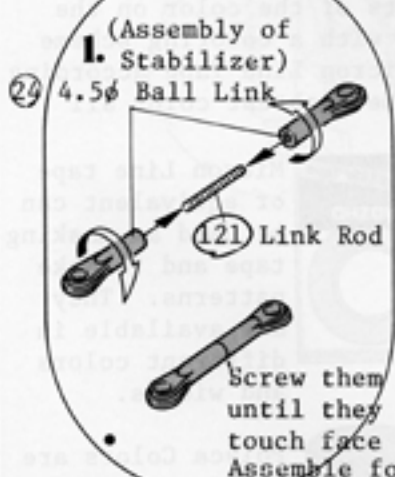

This portion will be applied for both right and left sides commonly in the same point.

Take the tie rod off once.

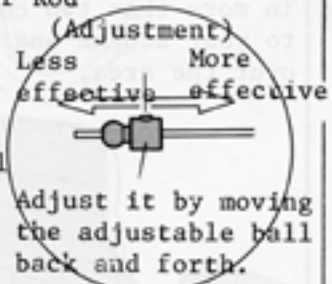

Adjust it by moving the adjustable ball back and forth.

The left side should be installed in the same way.

32 PREPARING OF BODY

*Cut out square holes for the rear body mounting holes so that there are some room to adjust the chain tension by shifting rear gearbox fore and aft.

The shears for cutting polycarbonate is available at Kyosho.

Use the curved jaw for curved lines.

*Cut off along the cutout lines indicated with shaded area.

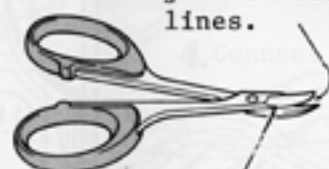
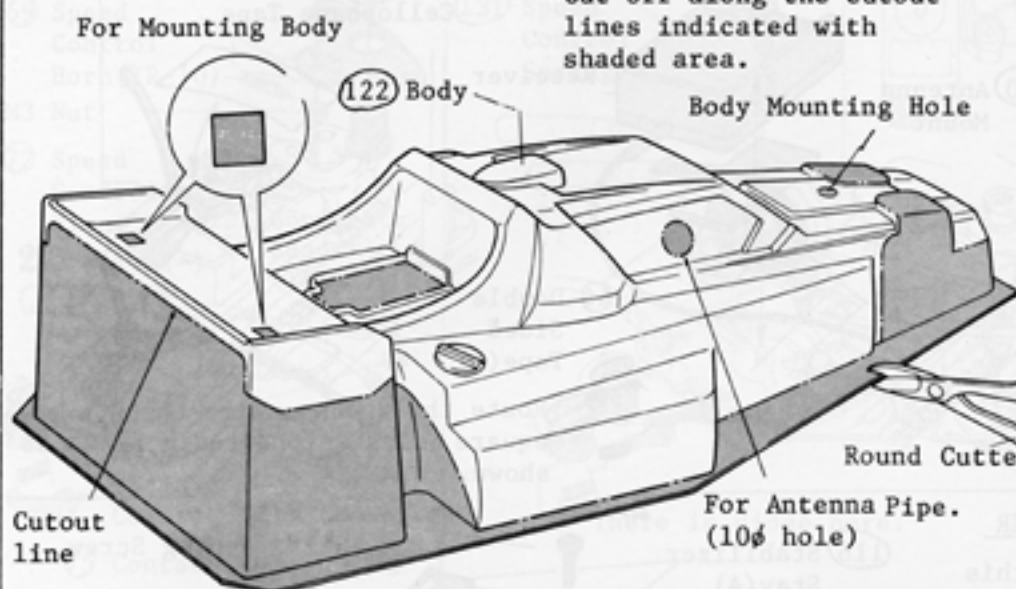

Apply the straight blades for straight lines.



32 PAINTING

The body of this model is made of polycarbonate, transparent plastic resin molded into the form. It is recommended to paint inside for a better finish. Also for better adhesion of the paint to the surface, wash it with neutral detergent and rinse it with water well. During the process of drying, be careful not to stain the surface with fat or thumb marks.

When you paint your Turbo Rocky only in one color, two or three coats of the color on the inside of the car body would be sufficient. If you like to paint it with a coloring scheme in more than two colors, mask the inside with masking tape or the Micron Line Tape according to your scheme and start with the darkest paint, and lastly apply the lightest color all over the area.

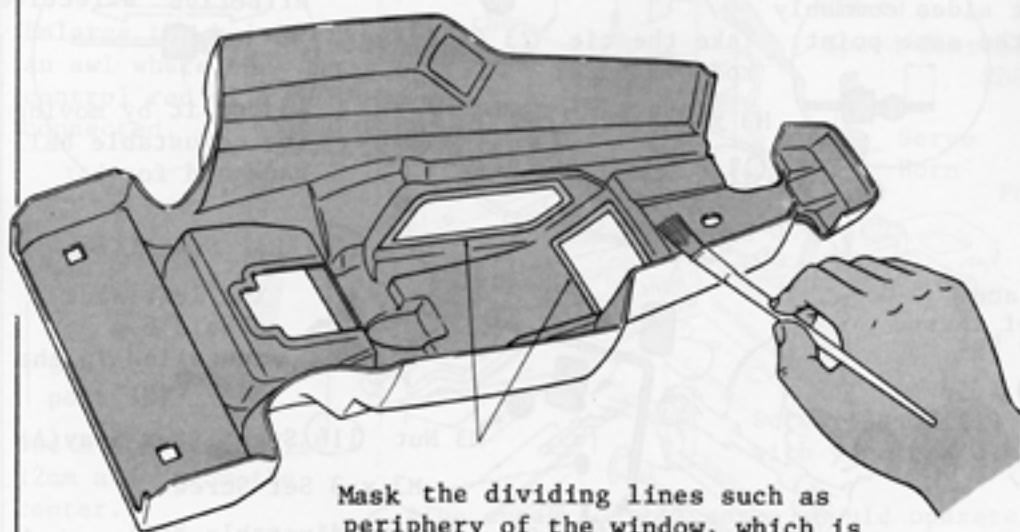

Mask the dividing lines such as periphery of the window, which is left as transparent, with the Micron Line Tape.



Micron Line tape or equivalent can be used as masking tape and to make patterns. They are available in different colors and widths.



Polycolors are paints composed exclusively for painting polycarbonate resin. They are very easy to use. Different colors are available.



Polycolor

34 MOUNTING OF BATTERY

③ Ni-Cad Strap (TR-9)

Turbo Racing 8.4V Battery (not included)

Fasten the strap tight and tuck in the excess strap into the square hole.

You can undo it by pushing here no matter how firmly the strap is fastened.

KYOSHO



Kyosho puts on the market a high power 8.4V Turbo Racing Battery which is composed of tabless type cells. It can discharge a lot of current at a time to give a model car excellent pick-up power and running ability.

BE SURE TO DISMOUNT THE NI-CAD BATTERY WHEN YOU WILL NOT RUN THE CAR OR KEEP IT IN STOCK.

35 MOUNTING OF BODY

⑬⑩ Body Pin

⑬⑩ Body Pin

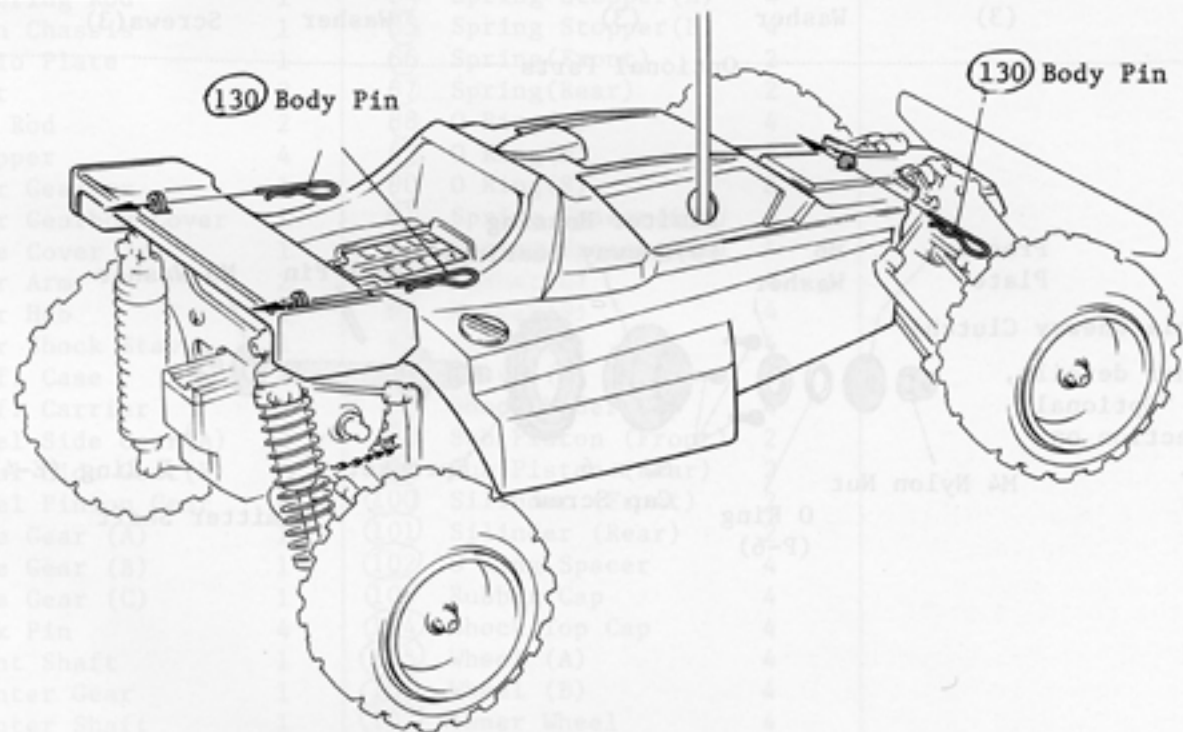

EXPLODED VIEW

(Oil Shock)

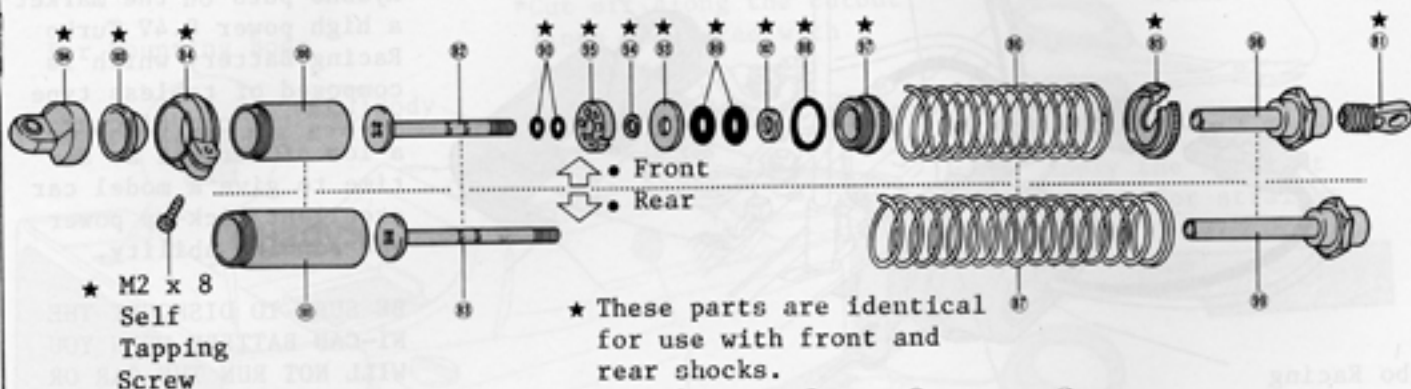

(Differential Gear)



Optional Parts

(Adjustable Oneway Clutch)

For further details, refer to "Optional Parts" section on page 28.

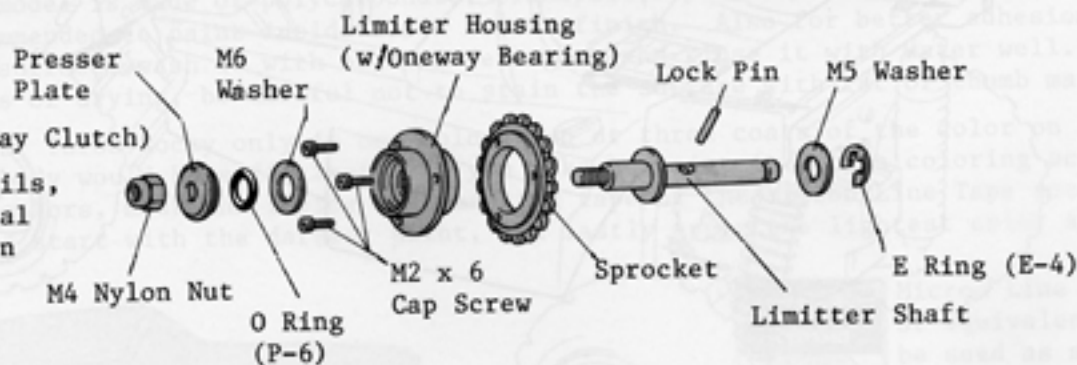

KEY NUMBERS FOR PARTS

No.	Parts Name	Q'ty	No.	Parts Name	Q'ty	No.	Parts Name	Q'ty.
1	Front Bumper	1	61	Chain Guide	1	120	Bracket (B)	2
2	Front Gearbox	1	62	Servo Mount	1	121	Link Rod	4
3	Front Gearbox Cover	1	63	Ni-Cad Strap	2	122	Body	1
4	Arm Bracket	1	64	Nylon Strap (M)	1	123	Thickness Gauge	1
5	Body Mount	1	65	Nylon Strap (S)	2	124	Connector Lead (A)	2
6	Front Arm	2	66	Double Sided Tape (A)	1	125	Connector Lead (B)	2
7	Arm Pin (45mm)	4	67	Double Sided Tape (B)	1	126	Shock Oil	1
8	Arm Pin (30mm)	4	68	Speed Control	1	127	Decal	1
9	Front Hub (R)	1		PG Board		128	1.5mm Allen Wrench	1
10	Front Hub (L)	1	69	Speed control Horn	1	129	Grease	1
11	Knuckle Arm (R)	1	70	Speed Control Holder	1	130	Body Pin	3
12	Knuckle Arm (L)	1	71	Speed Control Nut	1	131	Speed Control	1
13	King Pin	4	72	Speed Control Pivot	1		Spring	
14	5.8φ Ball	10	73	Speed Control Mount	1			
15	Upper Rod (30mm)	4	74	Contact Point	2			
16	5.8φ Ball Link	10	75	Contact Point Holder	2			
17	Front shock Stay	1	76	Connector (for 8.4V)	1			
18	Ball Bearing (5φx10φ)	4	77	Regulator	1			
19	Center Arm	1	78	Three Speed Register	1			
20	Center Collar	1	79	Register Cover	1			
21	5.8φ M3 Ball	2	80	Speed Control Rod	1			
22	5.8φ Pillow Ball	4	81	Shock End	4			
23	4.5φ Pillow ball	6	82	Main Piston (Front)	2			
24	4.5φ Ball Link	10	83	Main Piston (Rear)	2			
25	Steering Rod	1	84	Spring Stopper (A)	4			
26	Main Chassis	1	85	Spring Stopper (B)	4			
27	Radio Plate	1	86	Spring (Front)	2			
28	Post	2	87	Spring (Rear)	2			
29	Tie Rod	2	88	O Ring (L)	4			
30	Stopper	4	89	O Ring (M)	8			
31	Rear Gearbox	1	90	O Ring (S)	8			
32	Rear Gearbox Cover	1	91	Spring Spacer (6mm)	4			
33	Side Cover	1	92	Spring Spacer (3mm)	4			
34	Rear Arm	2	93	Washer (L)	4			
35	Rear Hub	2	94	Washer (S)	4			
36	Rear Shock Stay	1	95	Valve (A)	4			
37	Diff. Case	4	96	Valve (B)	4			
38	Diff. Carrier	2	97	Shock Under Cap	4			
39	Bevel Side Gear (A)	2	98	Sub Piston (Front)	2			
40	Bevel Side Gear (B)	2	99	Sub Piston (Rear)	2			
41	Bevel Pinion Gear	6	100	Silinder (Front)	2			
42	Idle Gear (A)	1	101	Silinder (Rear)	2			
43	Idle Gear (B)	1	102	O Ring Spacer	4			
44	Idle Gear (C)	1	103	Rubber Cap	4			
45	Lock Pin	4	104	Shock Top Cap	4			
46	Front Shaft	1	105	Wheel (A)	4			
47	Counter Gear	1	106	Wheel (B)	4			
48	Counter Shaft	1	107	Inner Wheel	4			
49	Sprocket (18T)	2	108	Tire	4			
50	Sprocket (19T)	1	109	Antenna Pipe	1			
51	Idle Shaft	1	110	Antenna Mount	1			
52	Joint	4	111	Servo Saver	1 set			
53	Drive Washer	4	112	Bushing (4φx8φ)	2			
54	Universal Swing Shaft	4	113	Bushing (5φx10φ)	12			
55	Pilot Shaft	2	114	Front Stabilizer	1			
56	Pinion Gear (14T)	1	115	Rear Stabilizer	1			
57	Motor Base	1	116	Stabilizer (A)	4			
58	Base Plate	1	117	Stabilizer (B)	4			
59	Chain	1	118	Adjustable Ball	4			
60	Chain Liner	1	119	Bracket (A)	2			

When your assembly is completed adjustment the following items:

Slide the rear gear box holder backward or forward to give the proper tension to the chain.

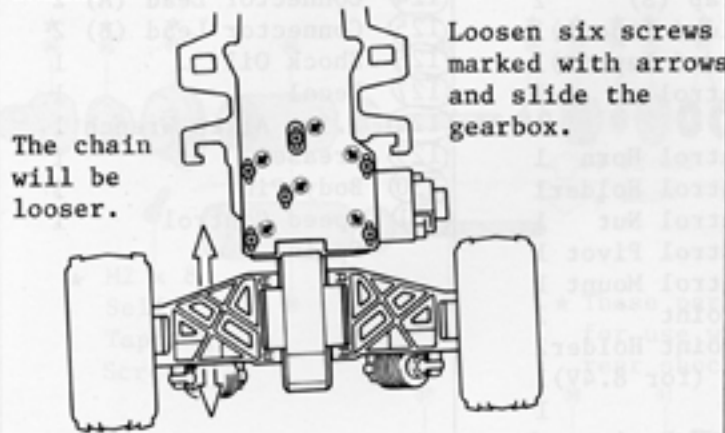

The chain will be looser.

Loosen six screws marked with arrows and slide the gearbox.

The chain will become tighter.

1. Ideal Tension of Chain

Set the chain so that it can be lifted up 10mm by finger at about the center of the slider, and you will attain smooth operation of the drive system.

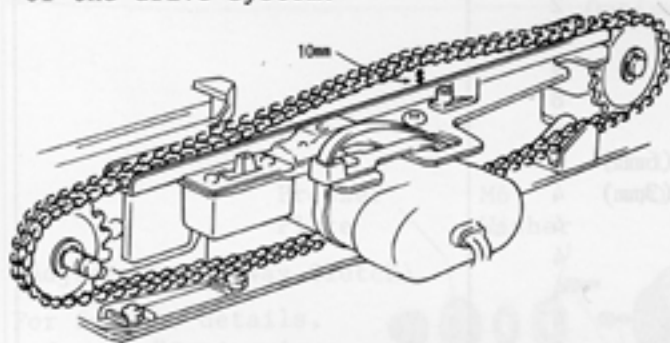

If the chain is too tight, the rotation of the chain becomes difficult, with considerable loss of power. If the chain is too loose, it flop around.

2. When the chain is stretched

In operation, the chain will slacken little by little. Check it from time to time to keep it in a good adjustment. When the chain has been stretched beyond the range of adjustment, remove one link out of the chain.

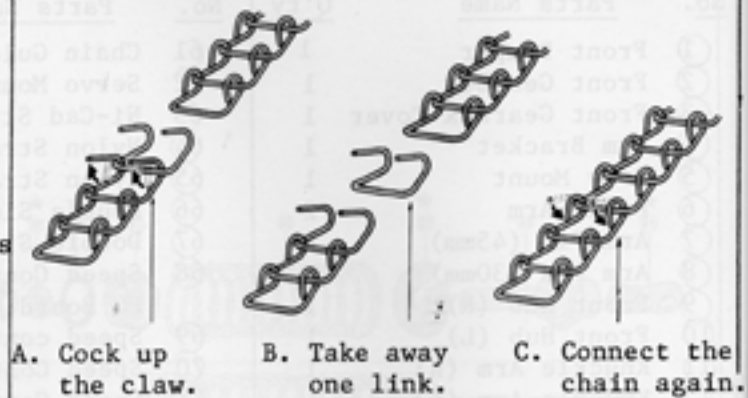

A. Cock up the claw. B. Take away one link. C. Connect the chain again.

(Adjustment of Suspension Spring)

1. In the case of adjusting it with the spring stopper.
2. In the case of adjusting it with the spring Spacer.

Leave a space of 5 to 10mm.

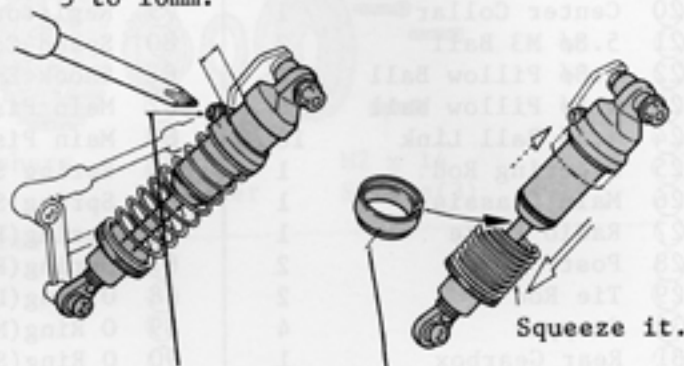

Loosen for adjustment (Adjust the right and left side springs under the equal tension.)

Spring Spacer (There are two kinds, 6mm one and 3mm one.)

(Adjusting of Speed Controller)

Plug in the connector from the speed controller to the 8.4V Ni-Cad battery and operate your radio. While adjusting, the wheel of car may start to run, so keep your model upon a small box to make the wheels aloof from the ground.

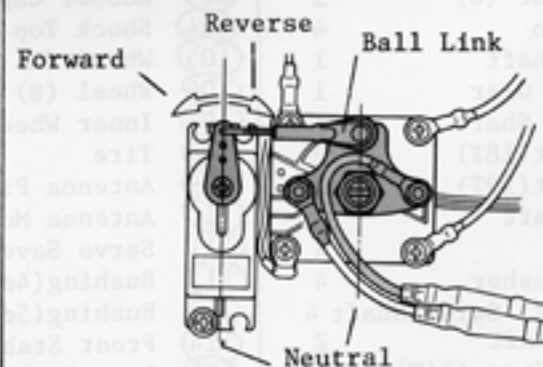

By turning the ball end, adjust the speed controller to the position shown in the drawing above (motor stopped position) with the control stick and the trim lever in neutral.

1. Adjustment for High Speed

When the control stick on your radio is pushed forward all the way, the controller should be activated and the motor should run at a high speed. By the motor sound, you can tell if the motor is running high, medium, or low speed.

High



Midium

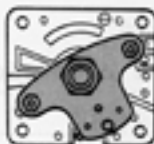

Low



2. Adjustment for Reverse

Pull the control stick and the control horn should operate as illustrated in the diagram below. The motor should run in reverse.



Servo Horn
(Bigger one)



If the movements described in 1 and 2 are not achieved, replace the servo horn with a bigger one.

(Toe-in Adjustment)

This is important for controlling a car. Set the front wheels converge a little toward the front. This adjustment helps the model run in a straight line and enhances the steering response.

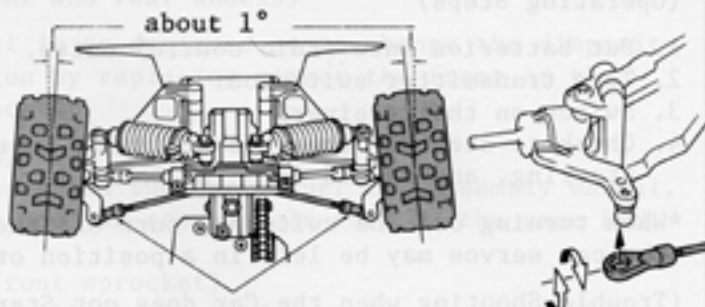

Adjust the nutral position and the toe-in angles with two ball links attached to the tie-rod.

Snap it on after acquiring the correct length.

(Oiling)



NO.1883
Frontier
Hobby Oil

Speed Controller



1. Apply a little amount of light oil, such as Frontier Hobby oil, to the shaft, bearings and joints. Wipe off any excessive oil with cloth. Do not use heavy oil as it attach mud and dust during a running of the car.
2. Do not oil to the speed control directly. Electric sparks may burn the oil. Whenever you feel that the speed controller needs lubrication, wipe the PC board lightly with a piece of cloth dampened with the Frontier Hobby oil.

CHECKING BEFORE RUNNING

Before running the car, check the parts in order of the numbers shown in the picture.

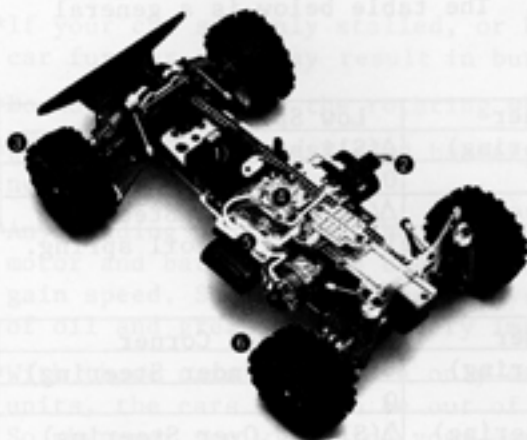

*Drive slowly the first time the car is run.

Continue driving slowly until the battery needs recharging. Check all moving parts on the car.

1. Check to see if all bolts, screws and nuts are tightened firmly.
2. Check to see if batteries for radio control units and the motor are charged fully.
3. Check to see if the front wheels steer in proportion to your control of the transmitter.
4. Check to see if the forward and reverse movement of the car responds accurately to your control.
5. Check to see that all wiring is properly insulated with vinyl tape.
6. Check to see that the rear wheels are free and can be turned by hand.

(Operating Steps)

1. Put batteries into radio control units. Install main Ni-Cad running battery.
2. Turn transmitter switch on.
3. Switch on the receiver.
4. Check to see that the sticks of your transmitter operate correctly, right and left for steering, and up and down for throttle.

*When turning off the switches, turn off the receiver first then transmitter. Otherwise, the car servos may be left in a position other than neutral.

(Trouble Shooting when the Car does not Start)

1. Poor contact of connectors of receivers, servos, batteries or of electric wiring.
2. Poor contact of the speed controller wiper blade.
3. Radio control units are out order.
4. Signal jamming from other radios.

*The radio control units in the Turbo Rocky is powered by the same battery which drives the motor. So, during a run, if you notice any drop of speed, retrieve the car at once and turn the switch off. The battery discharged below a certain limit cannot operate the radio control units and the car will be out of control.

GUIDE FOR SETTING UP THE CAR (2)

(Adjustment for Straight Going)



1. When the model runs unstably without touching the steering wheel:

*Increase the toe-in setting in a slight degree.

*Check the linkage system to see if there is no loose or stiff connection.

2. When the car runs straight and change the direction suddenly and excessively:

*Check the steering swing of the left and right wheels. Reduce it a little.

*Examine any looseness in the linkage. Especially, stiff connection will hamper the quick and proportionate reaction of the wheels to your control.

(Adjustment for cornering)



1. When the model shows a trait of over steering or spinning:

*Check the steering ratio of the left and right wheels. Reduction of the degree may be required.

2. When the car goes toward the outside of the course at corners:

*Practice to turn corners with the acceleration control. After mastering the technique to some degree, increase the steering ratio little by little.

(Adjustment of Shock and Suspension Spring)

Adjust the components based upon a bumpy or slippery road. The table below is a general indication for your reference;

1. Tension of Front Spring

Spring Tension	Straight	High Speed Corner	Low Speed Corner
Strong	0 (Slippery Road Δ)	Δ (Slight Over Steering)	Δ (Slight Under Steering)
Medium	0	0	0
Weak	0 (Bumpy Road X)	Δ (Slight Under Steering)	Δ (Slight Over Steering)

*Adjust the front springs mainly with the torsion plates, and finely with the coil spring.

2. Tension of Rear Spring

Spring Tension	Straight	High Speed corner	Low Speed Corner
Strong	0 (Slippery Road)	Δ (Slight Over Steering)	0(Slight Under Steering)
Medium	0	0	0
Weak	0 (Bumpy Road X)	Δ (Slight Under Steering)	Δ (Slight Over Steering)

3. Adjustment of Oil Shock

Use thicker oil, when the spring is set to high tension. No.1951 shock oil is recommended for a thick oil.

(Shifting the ratio of rotation between the front and rear wheels)

Rear Sprocket

Front Sprocket

This model is so designed as to change the disparity in rotation by replacing either the front or the rear sprocket.

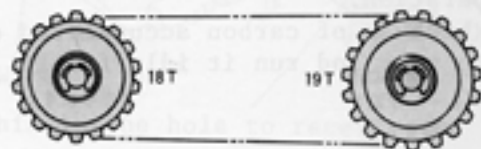

(Standard)

If you assembled the car as per the assembly manual, the front and the rear wheels turn in the same RPM.

(Bigger front sprocket)

The model will show a tendency of a front wheel driver car.

(Bigger rear Sprocket)

Since the rear rotates more, it tends to develop a trait of the rear wheel drive.

(Adjustment of Suspension Systems)

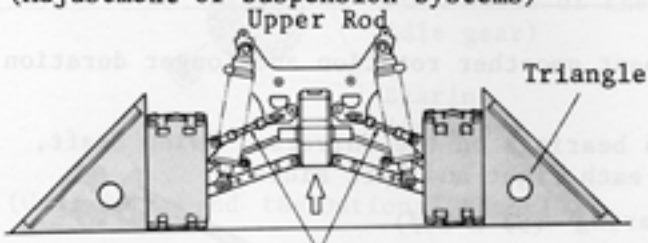

Place the car on a flat surface and turn the car body in the highest position; and adjust the length of the front and rear upper rod in such a way that the tires will stand at a right angle to the ground.

Negative
Camber

Upper Rod

By shortening the upper rod, you can have a negative camber adjustment.

Positive
Camber

Upper Rod

By lengthening it, you will have the positive adjustment.

WARNING FOR RUNNING THE CAR

The electric R/C car powered by a highly efficient Ni-Cad battery runs unexpectedly fast. So great care is required when you handle the car and the battery.

*Do not run the car in the crowd and on the road.

*Check the frequency bands when you see someone else also trying to run his car at a time with you. Radio control systems on the same frequency will respond each other and causing them to go out of control.

*If your car suddenly stalled, or being caught by some obstacles, do not try to move the car further. It may result in burning the motor or wiring or in damage on other parts.

*Do not try to hold the rotating wheels forcibly.

*When connecting the Ni-Cad battery, be sure that the speed controller is positioned in neutral.

*Any binding or drag on the bearing portion of driving system imposes heavy load to the motor and battery, thus causing overheating of the components or that the car does not gain speed. So check to see always if the driving system will turn smoothly. Application of oil and grease is also very important

*With those cars which have only one battery powering both the motor and the radio control units, the cars come to be out of control as the battery voltage is being dropped down. So whenever you will find your car losing speed, discontinue the operation.

MAINTENANCE AFTER A RUNNING

- *After a run of the radio controlled car, remove the Ni-Cad battery from the car and store it separately.
- *When you have finished running the car, clean dirt off the car.
- *Turn off the switches of the radio control units without fail.
- *Apply screw locking compound on the moving parts regularly.
- *Check that all screws and nuts are tightened properly.

HANDLING THE MOTOR

- *The motor becomes hot after each run. So continuous running may shorten its life. Do not run the car until the motor gets cool after each operation.
- *After several runs the motor may lose its power. This is because of carbon accumulated on the commutator of motor. In such a case, remove the pinion gear and run it idly for 15 minutes under 8.4V volts.
- *Oil the bearing of motor periodically.

OPTIONAL PARTS

(Bearing)

By employing the optional ball bearing, you can expect smoother rotation and longer duration of running.

(4 bearings on the Universal Swing Shaft, 2 each right and left sides.)

Bearing (5 ϕ x 10 ϕ)

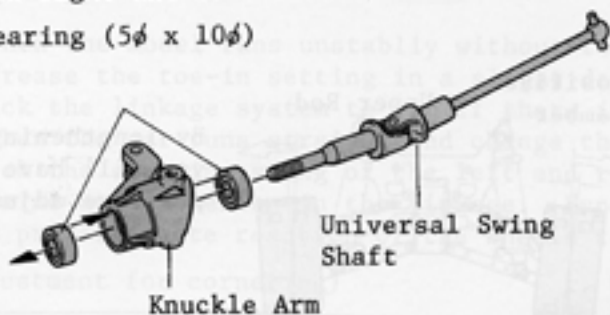

(4 bearings on the Universal Swing Shaft, 2 each right and left sides.)

Bearing (5 ϕ x 10 ϕ)

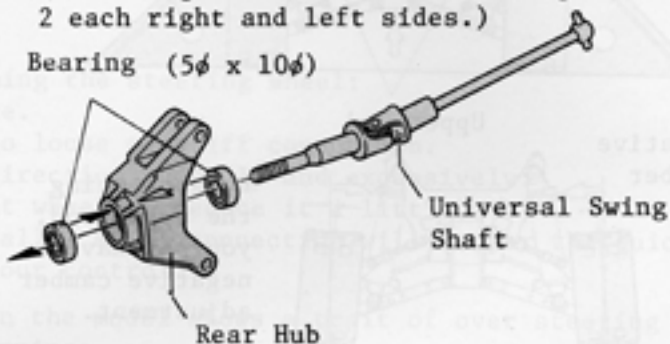

1 bearing each on both side of the rear gearbox.

Bearing (5 ϕ x 10 ϕ)

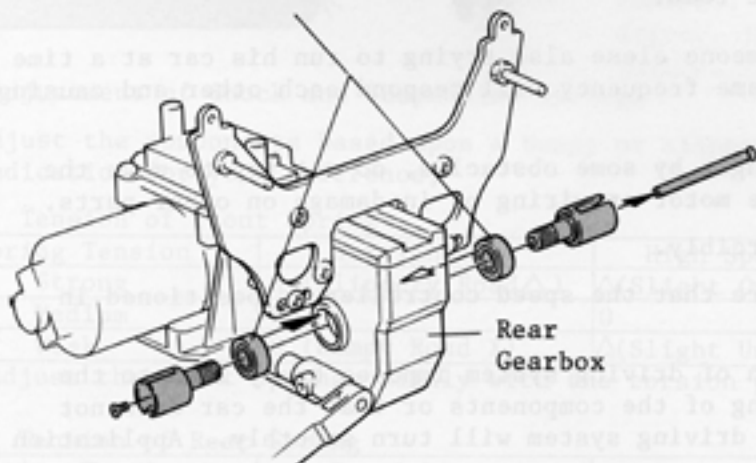

1 bearing each on both sides of the front gearbox.

Bearing (5 ϕ x 10 ϕ)

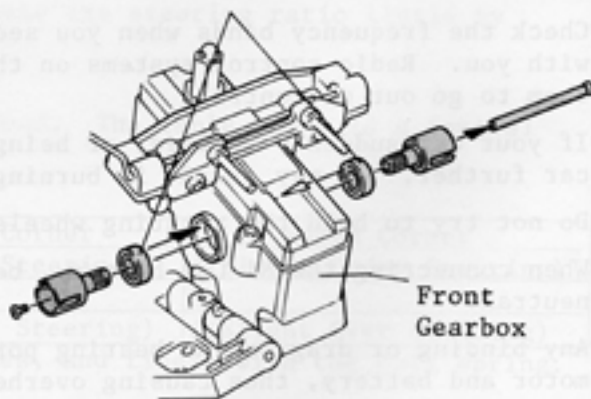

The ball bearings identified in the drawing above (5mm dia. x 10mm dia.) are used in 2 each. A set of No.1901 ball bearings, containing 2 each, are available from Kyosho. The Turbo Rocky uses six set.

(Adjustable One Way Clutch)

E Ring
(E-4)

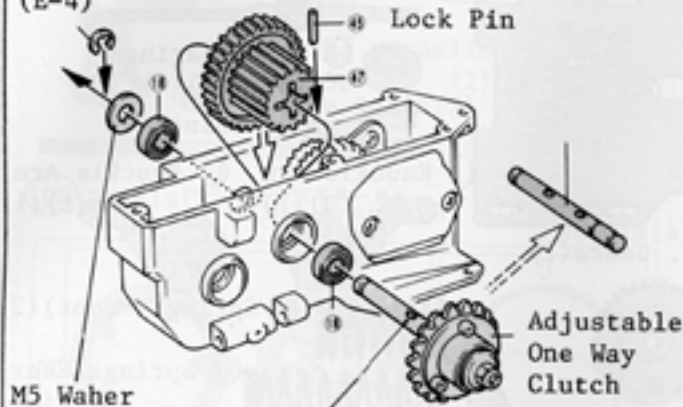

This is the hole to receive the lock pin.

Idle Gear



1 bearing each on both sides of the idle gear

Bearing
(4φ x 8φ)

By installing the optional adjustable one way clutch, you can improve the steering characteristics at corners or on the rough road surface, since the clutch will adjust the differential rotation between the front and rear wheels. Also it reduces the loss of power, thus the motor and the battery will be exempt from, otherwise, heavier load. (See page 22 for the exploded view.)

In the illustration left, the ball bearings (4mm dia. x 8mm dia.) are used in 2 each. A set of No.1903 ball bearings, containing 2 each, are available from Kyosho. Turbo Rocky uses one set.

(Gear Ratio and the Optional Motor)

Pinion Gear	15T	14T	15T	13T	14T	12T	13T	12T
Idle Gear	32T	32T	36T	32T	36T	32T	36T	36T
Gear Ratio	9.0	9.6	10.1	10.3	10.8	11.2	11.6	12.6
Le Mans 240S			—————					
Le Mans 240SB				—————				
Le Mans 360PT	—————							
Le Mans 360Gold	—————							
SPA 240WS Le Mans Sports H-240S		—————						
Speed	High Speed		—————				Low Speed	
Running Time	Short Time		—————				Long Time	

LIST OF BAGGED PARTS (1)

Blister

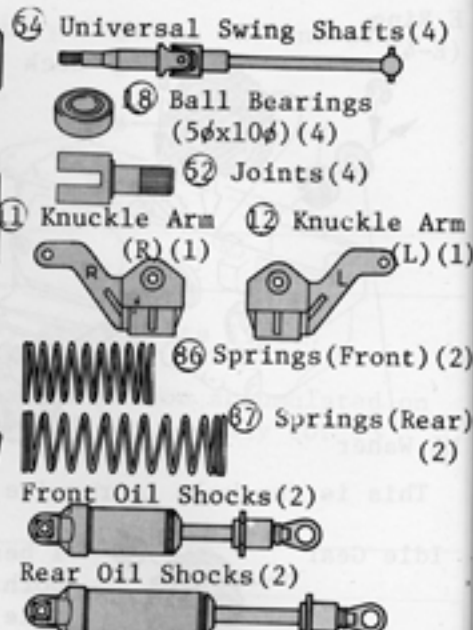
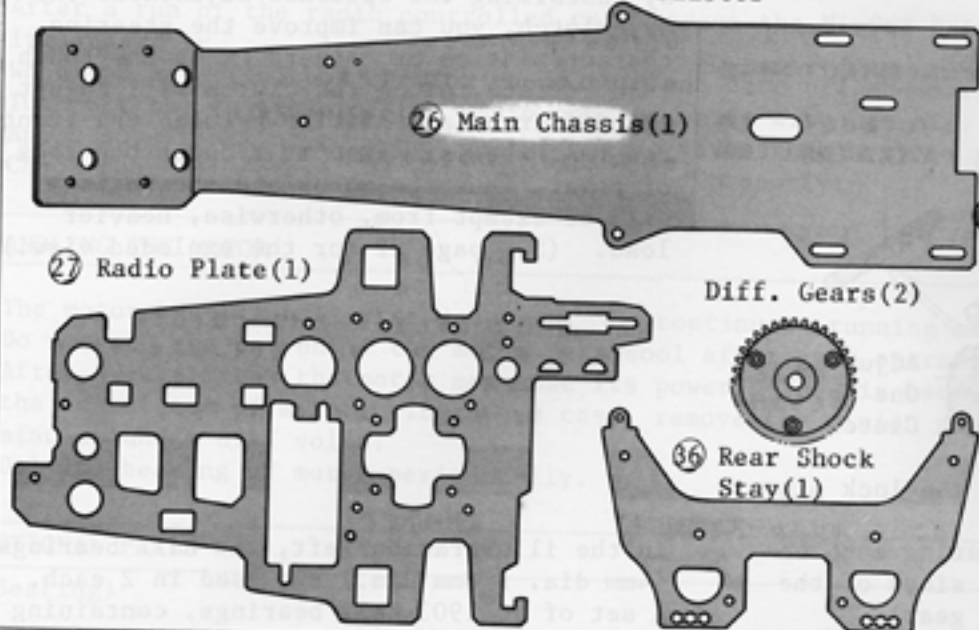

<TR-1>

<TR-2>

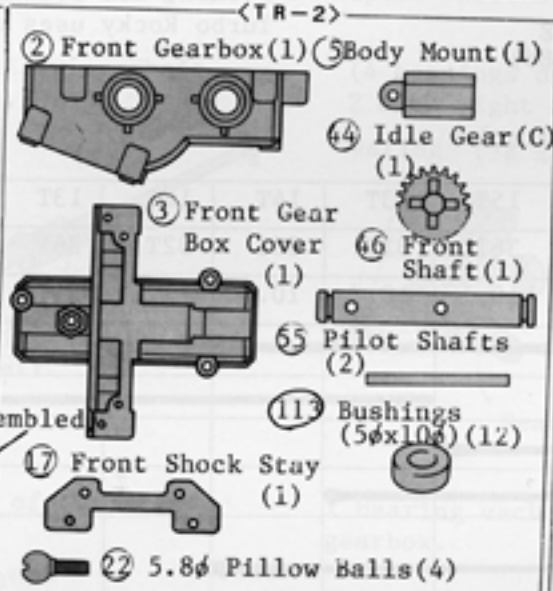

<TR-3>

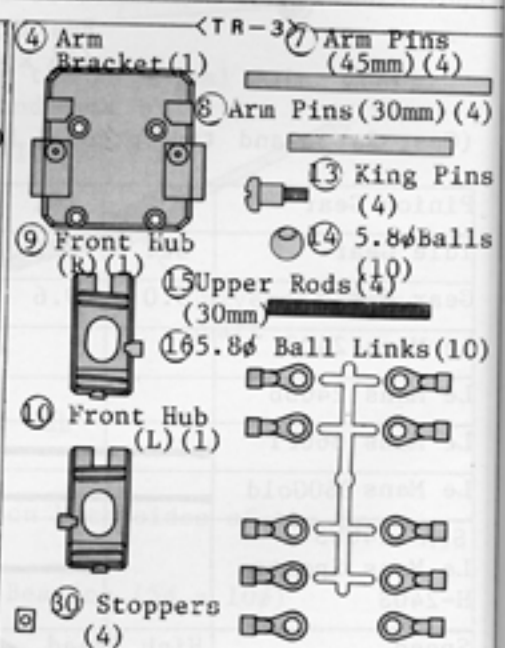

<TR-4>

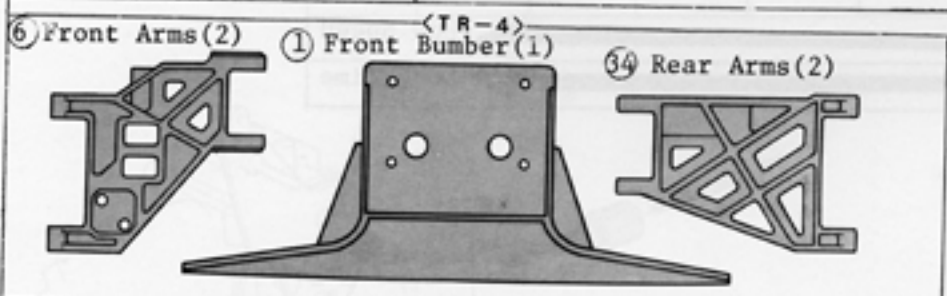

<TR-5>

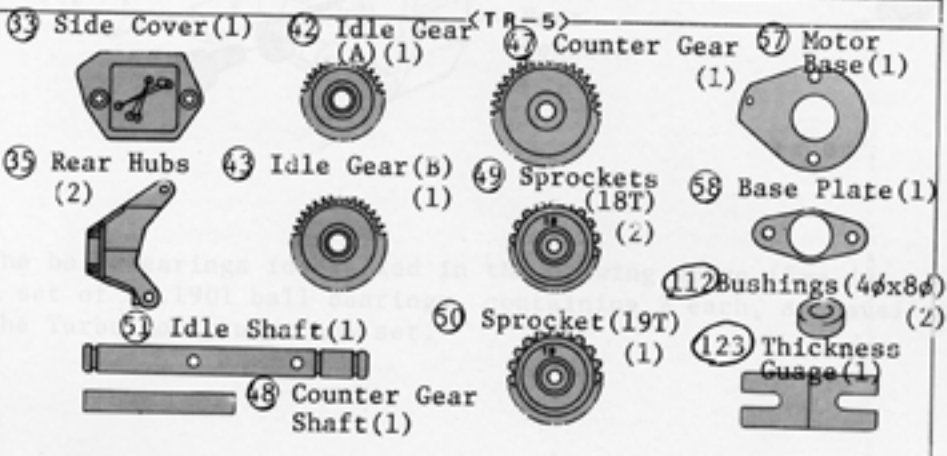

<TR-6>

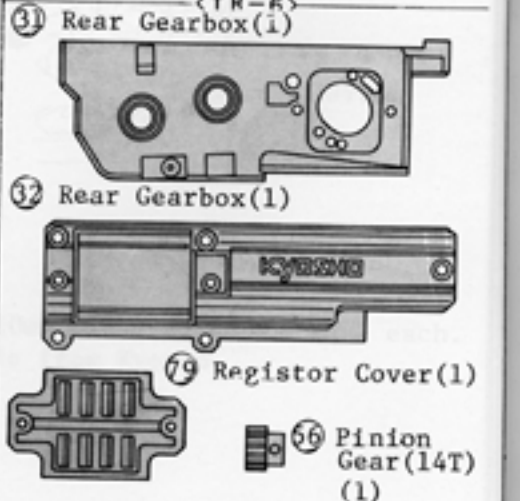

LIST OF BAGGED PARTS (2)

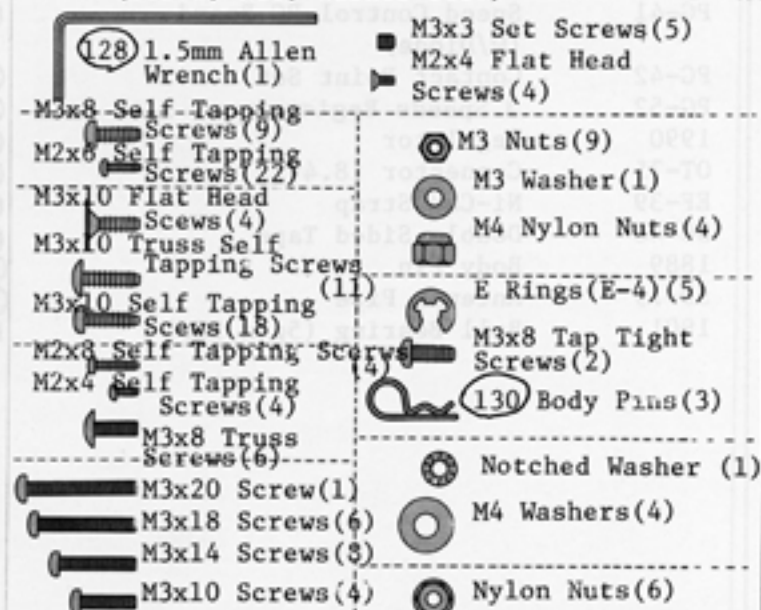
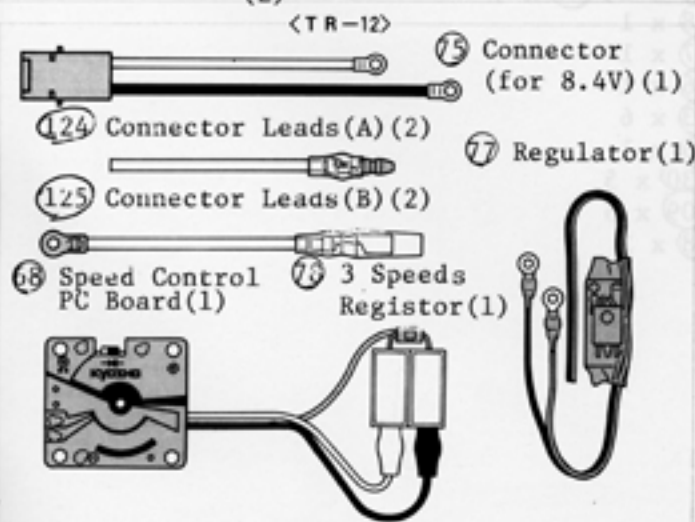
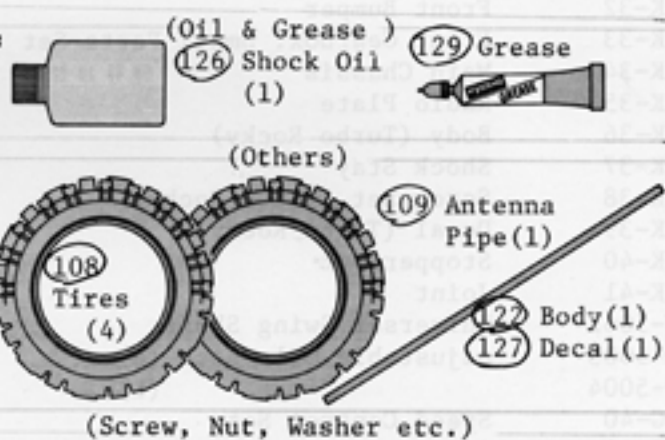
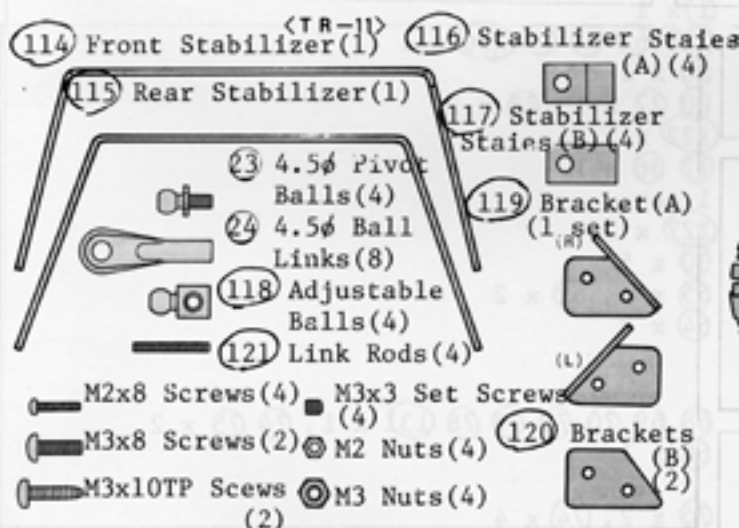
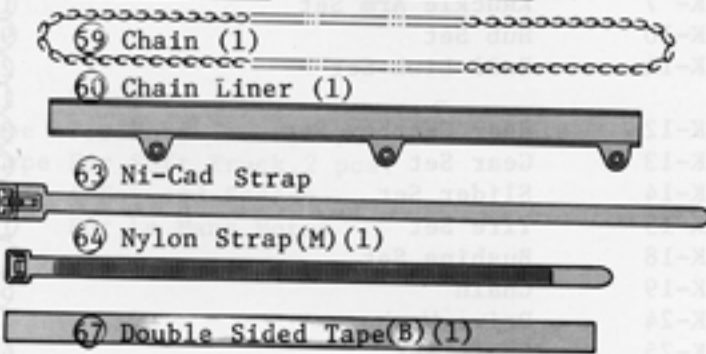
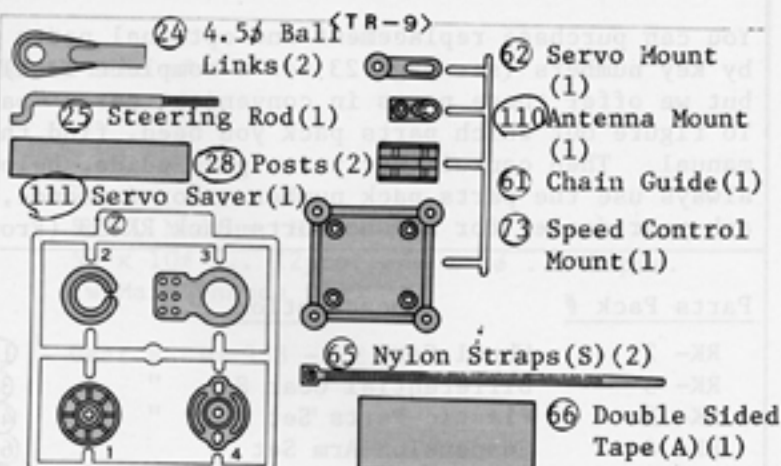
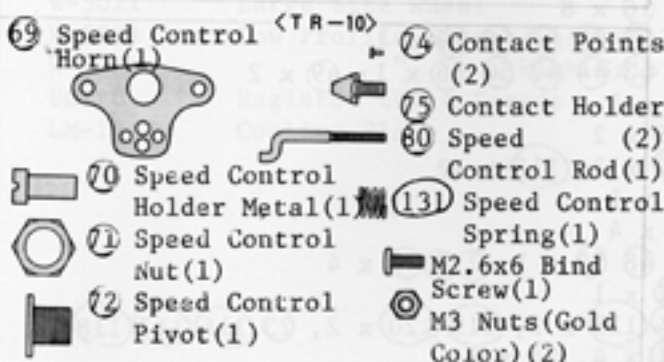
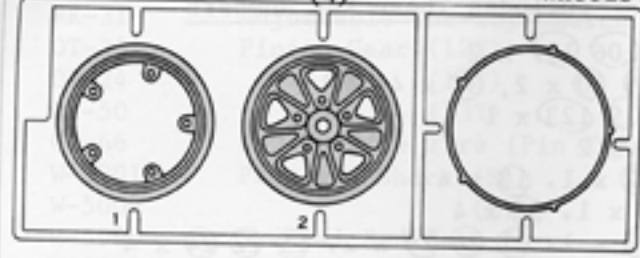
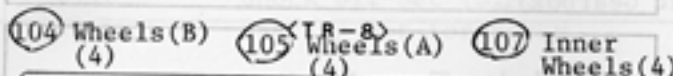
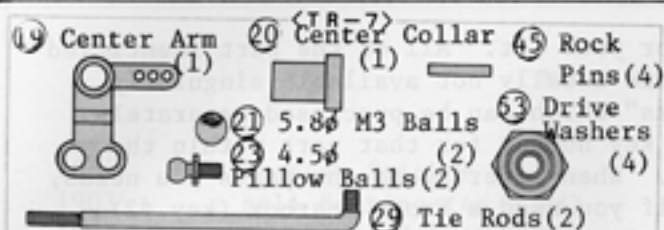

*Six black nylon nuts are contained in the bag (TR-1) Still being molded to the runner.

You can purchase replacement and optional parts for your kit. All of the part identified by key numbers (see page 23 for a complete list) are usually not available singularly, but we offer these parts in convenient parts "packs" which can be purchased separately. To figure out which parts pack you need, find the key number for that part within the manual. Then consult our parts pack guide, below. When referring to the parts you needs, always use the parts pack number. For instance, if you need a Front Gearbox (key #2) ask your dealer for Kyosho Parts Pack RK-33 (Front Gearbox).

Parts Pack #	Description	Includes These Key Numbers
RK- 2	Wheel Set	105 106 107 x 2
RK- 3	Differential Gear Set	38 39 40 x 2, 37 x 4, 41 x 6
RK- 5	Plastic Parts Set	4 5 19 23 x 1
RK- 6	Suspension Arm Set	6 34 x 2
RK- 7	Knuckle Arm Set	11 12 x 1, 13 x 4
RK-10	Hub Set	9 10 x 1, 35 x 4
RK-11	Ball Link Set	25 30 x 1, 21 24 29 x 2, 15 22 24 x 4 14 16 x 8
RK-12	Rear Gearbox Set	31 32 33 57 58 79 x 1
RK-13	Gear Set	42 43 44 47 50 56 x 1, 49 x 2
RK-14	Slider Set	60 x 1
RK-15	Tire Set	108 x 2
RK-18	Bushing Set	112 x 2, 113 x 12
RK-19	Chain	59 x 1
RK-24	Drive Washer	53 x 4
RK-25	Shaft Set	46 48 50 x 1, 7 8 45 x 4
RK-28	Servo Saver Set	111 x 1
RK-30	Stabilizer Set	114 115 x 1, 119 120 x 2, 23 116 117 118 121 x 4, 24 x 8
RK-32	Front Bumper	1 x 1
RK-33	Front Gearbox. Small Parts Set	2 3 61 62 73 110 x 1
RK-34	Main Chassis	26 x 1
RK-35	Radio Plate	20 27 x 1, 28 x 2
RK-36	Body (Turbo Rocky)	122 x 1
RK-37	Shock Stay	17 36 x 1
RK-38	Screw Set (Turbo Rocky)	1 set
RK-39	Decal (Turbo Rocky)	127 x 1
RK-40	Stopper Set	30 x 5
RK-41	Joint	51 x 1, 52 x 2
W-5062	Universal Swing Shaft	54 x 2
W-5003	Adjustable Oil Shock (S)	
W-5004	" (L)	
PG-40	Speed Control Set	68 69 70 72 73 78 131 x 1, 74 75 x 2
PG-41	Speed Control PC Board (w/Diode)	68 x 1
PG-42	Contact Point Set	73 x 2, 74 x 4
PG-52	3 Speeds Register	78 x 1
1990	Regulator	77 x 1
OT-75	Connector (8.4V)	76 x 1
EF-39	Ni-Cad Strap	53 x 6
SC-46	Double Sided Tape	66 x 1
1889	Body Pin	130 x 5
SD-79	Antenna Pipe	109 x 5
1901	Ball Bearing (5φ x 10φ)	18 x 2

*** Optional Part ***

1863	Sponser Sticker	
1903	Ball Bearing (4φ x 8φ)	2 pcs.
1951	Shock Oil Set (S,M,H)	Soft, Medium, Hard
1975	Bearing Set for Rocky	5φ x 10φ ... 12pcs. 4φ x 8φ ... 2-pcs. (w/Maintenance Oil)
RK-31	Adjustable One-way Clutch	
OT-23	Pinion Gear (12T)	Gear Ratio 9.8 - 12.93
OT-24	" (15T)	" "
OT-50	" (13T)	" "
OT-66	Low Profile Tire (Pin Type)	
W-5001	Presser Shock (S)	
W-5002	" (L)	
W-5005	Special Rod Set	
W-5021	Large Size Wheel	Silvered
W-5031	Low Profile Tire, Allround Type	For Hard Truck, 2 pcs.
W-5032	" , High Grip Type	For Soft Truck, 2 pcs.
SC-80	Register for 4 Speeds	4 Forward Speeds
LM-15	Cooling Plate	For Le Mans Motor

SMALL PARTS NEEDED (1)

1 ASSEMBLY OF GEARBOX

- M2 x 4 Flat Head Screws(2)
- M3 x 10 Self Tapping Screws(4)
- E Ring (E-4)
- 45 Lock Pin(TR-7) (1)
- 18 Ball Bearings (5φx10φ) (2) (Blister)
- 52 Joints(2) (Blister)
- 5 Body Mount(1) (TR-2)
- 22 5.8φPillow Balls (2)
- 16 Front Shaft(1) (TR-2)
- 55 Pilot Shaft (1) (TR-2)
- 113 Bushings (5φx10φ) (2) (TR-2)

2 INSTALLATION OF KNUCKLE ARM

- 13 King Pins(4) (TR-3)
- 22 5.8φ Pillow Balls (2) (TR-2)
- 113 Bushings(5φx10φ) (4) (TR-2)

3 ASSEMBLY OF FRONT SUSPENSION

- M2 x 4 Self Tapping Screws(2)
- M3 x 3 Set Screws(2)
- 7 Arm Pins(45mm) (2)
- 8 Arm Pins(30mm) (2)
- 30 Stoppers(2)

4 ASSEMBLY OF FRONT PORTION

- M3 x 18 Screws(2)
- M3 x 14 Screws(2)
- M3 x 10 Self Tapping Screws(2)
- M3 x 10 Truss Self Tapping Screws(4)
- M3 Nuts(2)
- 14 5.8φ Balls(2) (TR-3)
- 15 Upper Rods(30mm) (2)(TR-3)
- 16 5.8φ Ball Links (TR-3)(4)

5 ASSEMBLY OF OIL SHOCK

- M2 x 8 Self Tapping Screws(4)
- 93 Washers(L) (4) (TR-1)
- 95 Valves(A) (4) (TR-1)
- 103 Rubber Caps(4) (TR-1)

6 ATTACHMENT OF BUMPER AND FRONT SHOCK

- M3 x 10 Flat Head Screws(4)
- M3 x 10 Screws(2)
- Nylon Nuts(Plastic) (2)
- Plastic Collars (Thicker one) (2)
- 14 5.8φ Balls(2) (TR-3)

7 MOUNTING OF MOTOR

- M3 x 3 Set Screw(1)
- M3 x 10 Screws(2)
- 123 Thickness Gauge (1) (TR-5)

8 ASSEMBLY OF REAR GEARBOX (1)

- M3 x 10 Self Tapping Screws(2)
- 5 Idle Shaft(1) (TR-5)
- 112 Bushings (4φx8φ) (2) (TR-5)

9 ASSEMBLY OF REAR GEARBOX (2)

- E Ring(E-4) (1)
- 18 Ball Bearings (5φx10φ) (2) (Blister)
- 45 Lock Pin(1) (TR-7)
- 48 Counter Shaft(TR-5) (1)

10 ASSEMBLY OF REAR GEARBOX (3)

- M2 x 4 Flat Head Screws(2)
- 52 Joints(2) (Blister)
- 55 Pilot Shaft(1) (TR-2)
- 113 Bushings (5φx10φ) (2)

11 FIXING OF GEARBOX COVER

- M3 x 10 Self Tapping Screws(5)

12 INSTALLATION OF REAR SHOCK STAY

- M3 x 10 Self Tapping Screws(2)
- M3 x 14 Screws(2)
- M3 x 18 Screws(4)
- M3 Nuts(4)

13 ASSEMBLY OF REAR SUS. ARM

- M2 x 4 Self Tapping Screws(2)
- 7 Arm Pins(45mm) (2) (TR-3)
- 8 Arm Pins (30mm) (2) (TR-3)
- 11 Bushings (5φx10φ) (TR-2) (4)

14 INSTALLATION OF REAR UPPER ROD

- M3 x 14 Screws(2)
- Nylon Nuts(Plastic) (2)
- 16 Upper Rods(30mm) (2) (TR-3)
- 17 5.8φ Ball Link (TR-3)
- 26 5.8φ Balls(4) (TR-3)

15 INSTALLATION OF REAR SHOCK



- M3 x 14 Screws(2)
- Nylon Nuts(Plastic) (2)
- Plastic Collars (Thinner one) (2)
- Plastic Collars (Thicker one) (2)
- 14 5.8φ Balls(2) (RO-3)

16 INSTALLATION OF TIE ROD





- M3 x 20 Screw(1)
- 16 5.8φ Ball Links(2) (TR-3)
- 29 Center Collar (1) (TR-7)
- 21 5.8φ M3 Balls(2) (TR-7)
- 23 4.5φ Pillow Ball (1) (TR-7)
- 29 Tie Rods(2) (TR-7)

SMALL PARTS NEEDED (2)

17 MOUNTING OF RADIO PLATE

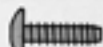
- M3 x 8 Self Tapping Screws(4) 
- M3 x 8 Truss Screws(4) 
- M3 x 10 Truss Self Tapping screws(3) 



18 INSTALLATION OF REAR PORTION

- M3 x 8 Truss Screws(2) 
- M3 x 10 Truss Self Tapping Screws(4) 
- M3 Nuts(2) 
- Notched Washer (1) 
- E Rings (E-4)(2) 
- Lock Pins(TR-7)(2) 



19 FABRICATION OF TIRE

- M2 x 6 Self Tapping Screws(2) 

20 MOUNTING OF TIRE

- M4 Nylon Nuts(4) 
- M4 Washers(4) 
- Drive Washers(4)(TR-7) 



22 MOUNTING OF SERVO SAVER

- M2 x 6 Self Tapping Screws(2) 
- M3 x 10 Self Tapping Screw(1) 

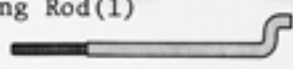

23 MOUNTING OF STEERING SERVO

- 4.5φ Ball Link(1) 
- Steering Rod(1) 









24 INSTALLATION OF SPEED CONTROL

- M3 x 10 Self Tapping Screws(2) 
- M3 Washer(1) 

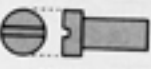

27 INSTALLATION OF PC BOARD

- M2.6 x 6 Bind Screw(1) 
- M3 x 8 Self Tapping Screws(4) 

28 FIXING OF CONTROL HORN

- M3 Nut (1) 
- M3 Nuts(Gold Color)(2) 
- 4.5φ Pillow Ball(1)(TR-7) 
- Speed control Hold Metal (1)(TR-10) 
- Speed Control Nut (1)(TR-10) 
- Speed Control Pivot (1)(TR-10) 
- Contact Points (2)(TR-10) 
- Contact Point Holders(2)(TR-10) 
- Speed Control Spring (1) 















29 FIXING OF SPEED CONTROL ROD AND REGISTOR COVER

- M3 x 8 Tap Tights(2) 
- 4.5φ Ball Link(1)(TR-9) 
- Speed control Rod(1)(TR-10) 

30 INSTALLATION OF RECEIVER AND ANTENNA

- M3 x 8 Self Tapping Screw (1) 

31 INSTALLATION OF STABILIZER

- M2 x 8 Screws(4)(TR-11) 
- M3 x 8 Screws(2)(TR-11) 
- M3 x 10 Self Tapping Screws (TR-11) 
- M3 x 3 Set Screws(4)(TR-11) 
- M2 Nuts (4)(TR-11) 
- M3 Nuts (4)(TR-11) 
- 4.5φ Pillow Balls(4)(TR-11) 
- 4.5φ Ball Links (8)(TR-11) 
- Stabilizer Stais(A)(2)(TR-11) 
- Stabilizer Stais(B)(4)(TR-11) 
- Adjustable Balls(4)(TR-11) 
- Bracket(A) (1 set) 
- Bracket(B)(2) 
- Link Rods(4) 

35 MOUNTING OF BODY

- Body Pins(3) 



SUPPLEMENTAL INSTRUCTION FOR TURBO ROCKY
=====

* This is supplemental instruction for some changes.

- (1) For 5 Assembly of Oil Shock on Page 5.
For Exploded View of Oil Shock on Page 22.
For Bagged Parts TR-1 on Page No. 30.
For Purchasing Parts for your kit on Page 32.

The kit includes two types of the 103 rubber caps for the oil shock; 2 each of thinner ones and thicker ones. Be carefull no to mistaken them.



For Rear Shock Thicker



For Front Shock Thinner

- (2) For TR-12 Bagged Parts (2) on Page No. 31.

Illustration of (75) connector was changed as below:-

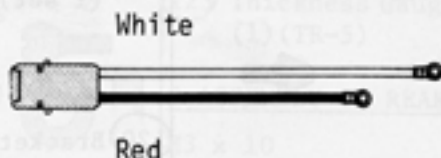

- (3) For 17 Mounting of Radio Plate on Page No. 11.
For TR-9 Vagged Parts (2) on Page No. 31.

Illustration of (28) Post was changed as below:-

