

RADIO CONTROLLED ELECTRIC POWERED OFF-ROAD RECREATIONAL VEHICLE

CAR CRUSHER Hi-Rider Corvette

- CAR CRUSHER FUN IN MINIATURE! CLIMBS OVER HIGH OBSTACLES!
- SUPER WIDE MONSTROUS 146MM DIAMETER SPIKE TIRE HIGH-GRIP ROAD HOLDING.
- DOUBLE WISHBONE FOUR WHEEL INDEPENDENT SUSPENSION HUGE EIGHT FRICTION SHOCKS.
- REALISTIC BODY SCALE DOWN USA TOP QUALITY SPORT CAR "CORVETTE".
- HIGH-POWER LE MANS STOCK 05 MOTOR INCLUDED.
- ROTARY SPEED CONTROL THREE STEPS FWD ONE REVERSE.

1:10 SCALE



KYOSHO
THE FINEST RADIO CONTROL MODELS

KIT NO.3107

Hi-Rider Corvette

BEFORE ASSEMBLY

* Read the instruction carefully.



You can assemble the kit more easily if you have grasped the general idea of steps and structure beforehand by reading it through to the end.

* Check the parts in the kit. Check to see if all the parts are correctly bagged as they are listed in the List of Bagged Parts. Your thorough understanding of the assembly prior to starting will enable you to build the kit without any difficulty.

What, the back is this OK

Check the components in the kit prior to your starting the assembly.



List of bagged parts

Any claims for replacements or refunds for the model in the process of assembly will not be accepted without shortage or inferiority of the parts.

* Learn on the marks described in the instruction.

Steps where your particular attention is required.



GREASE ... Place where grease should be applied. (It will reduce friction to assure smooth movements.)

* Be well aware of the different types of screws.
1. The difference between the TP screw (short form of self-tapping screw) and the ordinary screw is...

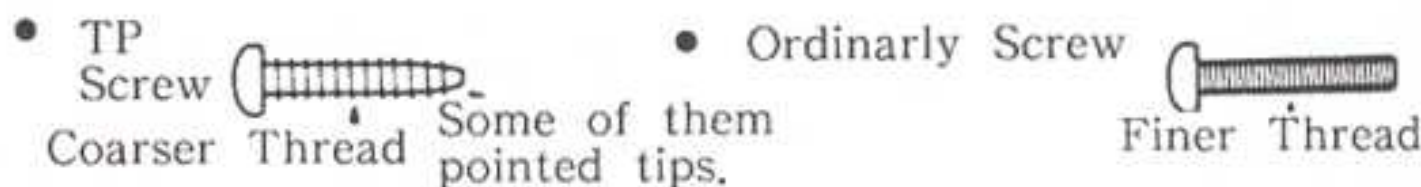

2. The kinds of screws which will be used in this instruction.

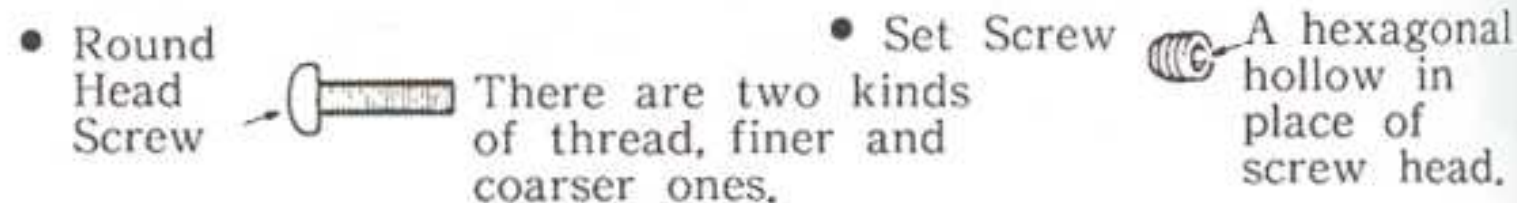

Check up parts with the list.



* Pick up the correct parts and screw. Compare the shape and size of small parts, such as screws, nuts, and washers with the attached sheet of "List of Small Parts".

* Be sure about the location and direction of parts to install.

Double-check the location and orientation of parts with the illustration before installation. When necessary, assemble the parts themselves tentatively before proceeding to the next step.



* Do not tighten the TP screw too strong... Do not use excessive force when tightening the TP screws, or you may strip the thread in the plastic. It is recommended to stop tightening it when the thread part on the screw goes into the plastic part and you feel some resistance from the tightening.

Let me see, is this the right side part, or left one?

Over tighten may strip the thread in the plastic.

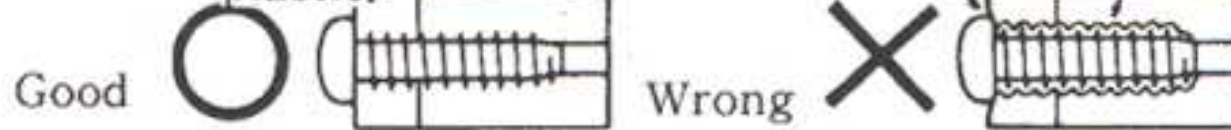

THINGS NEED BESIDES THE KIT [2 Channel Radio System]

This model is designed for BEC system radio only. Use a radio which has a mark shown at left.



Two types of radio control set are on the market, the stick type and the steering wheel type. Choose which ever you like.

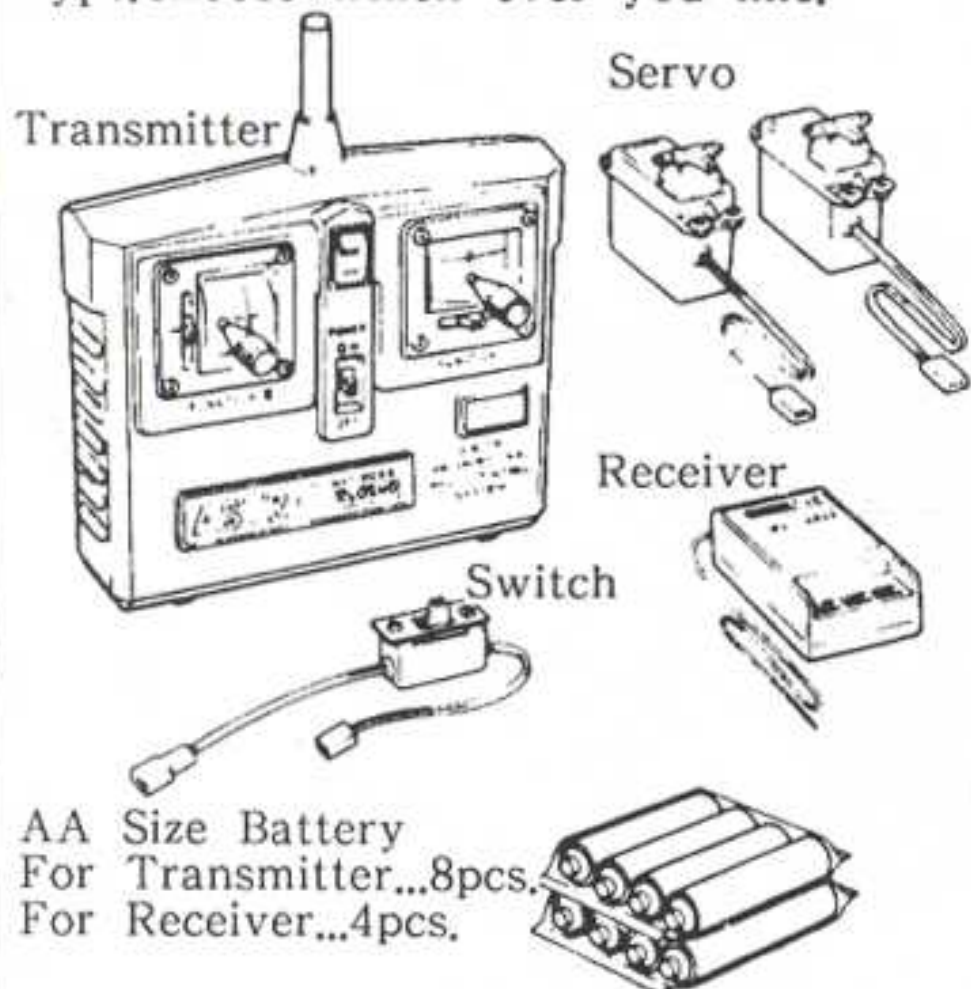

AA Size Battery For Transmitter...8pcs. For Receiver...4pcs.

[NiCd Battery]

Any of these batteries is suitable to Hi-Rider Corvette.

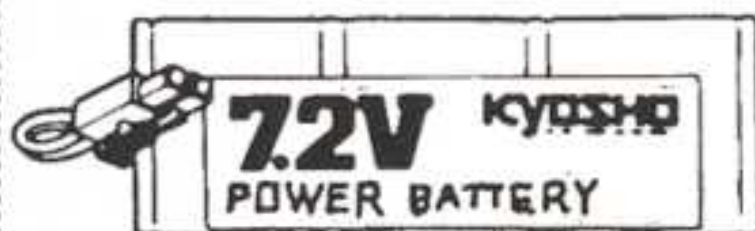

7.2V Sprint Battery - SCR.



7.2V Racing Battery

7.2V Power Battery

"Corvette Hi-Rider" is designed to use a rechargeable 7.2V Sprint Battery SCR, 7.2V Racing Battery and 7.2V Power Battery.

[Charger for NiCd Battery]

The Kyosho's NiCd battery is high performance. If it is charged correctly, it will operate for a considerable period.

Use one of the chargers listed below which suits your need

Model	Name	Time	Rate%	Features
No.2221	Super NiCd Charger (AC100V)	14 to 16hrs.	100%	For beginners
No.2326	7.2V Power Quick Charger (DC12V)	15 min.	about 70%	For beginners Timer built in
No.1849	Multi Charger II (DC12V)	20 min.	100%	Timer, Ammeter built in
No.1845	Delta Peak Charger (DC12V)	about 20 min.	100%	Ammeter built in, Automatic cut-off at peak of charge
No.2232	Super NiCd AC Rapid Charger (AC100V)	about 40 min.	about 80%	Chargeable from Household outlet. Electronic timer built in

[Required Tools] Hex key, Grease and CW cement are included with the kit.

Philips Screw Driver (L,M,S)



Box Driver (for M3 & M4 Nut)

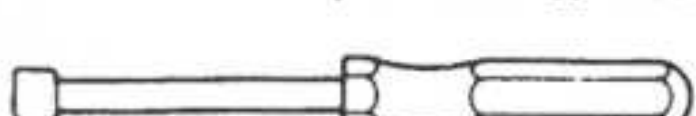

Sharp Hobby Knife

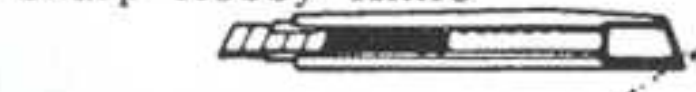

Needle Nose Plier

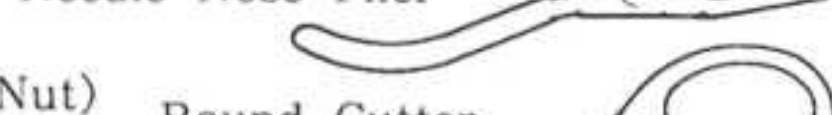

Round Cutter



Sander

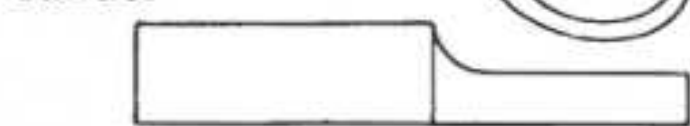

Awl



Wire Cutter



Instant Blue



Brush



Polyca Paint



Micron Line Tape



LIST OF BAGGED PARTS "HI-RIDER CORVETTE"

Bag	Key #	Parts Name	Q'ty	Step
Blister	1	8 φ Pillow Ball	8	3
	2	5.8 φ Pillow Ball	16	4, 5, 10
	3	Rotary Speed Controller	1	7
	4	Front Wheel Shaft	2	21
	5	Rear Wheel Shaft	2	10
	6	Le Mans Stock 05 Motor	1	17
	7	Pinion Gear (13T)	1	17
	8	Resistor	1	20
HRD-1	9	Bulk Head A	1	4
	10	Bulk Head B	1	4
	11	Gearbox A	1	1
	12	Gearbox B	1	2
HRD-2	13	Knuckle Arm A	2	3
	14	Knuckle Arm B	2	3
	15	Upper Suspension Arm	4	3
	16	Lower Suspension Arm	4	3
HRD-3	17	Main Frame	1	4
	18	Cover	1	18
HRD-9	19	Shock Stay FR	1	14
	20	Shock Stay FL	1	14
	21	Shock Stay RR	1	14
	22	Shock Stay RL	1	14
	23	Front Body Mount	1	14
	24	Rear Body Mount	1	14
	25	Slider	1	9
	26	Gear Cover	1	17
HRD-4	27	Block Parts B	1	4, 7, 8, 12, 16
HRD-5	28	Block Parts C	4	18
HRD-7	29	Front Guard	1	11
	30	Front Side Guard R	1	11
	31	Front Side Guard L	1	11
HRD-6	32	E Block Parts	1	12, 16
HRD-10	33	Differential Joint	2	1, 2
	34	Differential Side Gear	2	1, 2
	35	Idle Gear	1	1
	36	Counter Gear	1	2
	37	Differential Carrier	1	2
	38	Differential Bevel Gear	3	2
	39	D Block Parts	1	1, 2, 10
	40	Z Block Parts	1	8
	HRD-11	41	5.8 φ Ball Link	20
42		Idle Gear Shaft	1	1
43		Idle Gear Shaft Pin	1	1
44		Counter Gear Shaft	1	2
45		Differential Joint Shaft	1	1
46		Suspension Shaft A	6	5
47		Suspension Shaft B	2	5
48		Shock Shaft	8	18
49		Wheel Shaft Pin	4	21
50		Ball Seat	8	3
51		M3 Rod A	4	10
52		M3 Rod B	2	10
53		4 φ Plain Bearing	2	1
54		5 φ Plastic Bearing	8	3
55		Pillow Ball	2	4
2		5.8 φ Pillow Ball	4	4
HRD-12		56	4.5 φ Ball Base	1
	57	4.5 φ Ball Link	1	7
	58	Knuckle Collar	2	10
	59	Speed Control Rod	1	7
	60	Double Sided Tape (Thicker)	1	2, 4, 5, 5
	61	Rubber Pipe	2	10, 5
	62	Motor Cord	1	17
	63	Resistor Cover	1	20

Bag	Key #	Parts Name	Q'ty	Step
HRD-12	64	Resistor Holder Base	1	20
	65	Shock Spring	4	18
	66	Wheel Hub	4	21
	67	Grease	1	
	68	Vinyl Tie	1	18
HRD-8	69	Engine Head	1	23
	70	Engine Base	1	23
	71	Engine Front	1	23
	72	Exhaust Pipe A	1	23
	73	Exhaust Pipe B	1	23
	74	Air Scoop A	1	23
	75	Air Scoop B	1	23
HRD-13	76	Window	1	18
	78	Light Case A (L,R)	1	25
	79	Light Case B (L,R)	1	25
	80	Double Sided Tape (Thin)	1	25
	81	Nylon Strap	1	
	82	Antenna Pipe	1	28
Others	83	Decal	1	
	84	Instruction	1	
	85	Tire	4	31
	86	Wheel A	4	31
	87	Wheel B	4	31
	88	Wheel C	4	31
	89	Body	1	25
	90	Eyelet	2	14, 9
	91	Body Pin	5	12
	92	Hook Pin	4	
HRD-14		TP Screw M3×16	18	
		TP Screw M3×12	53	
		TP Screw M3×8	25	
		TP Screw M2×6	34	
		Screw M3×60	1	
		Screw M3×28	4	
		Screw M3×25	8	
		Screw M3×12	16	
		Screw M3×8	5	
		Screw M2×15	1	
		Screw M2×10	3	
		Set Screw M3×3	1	
		Washer 8φ	2	
		Washer 5φ	8	
		Washer 3φ	10	
	Nylon Nut M4	4		
	Nylon Nut M3	9		
	Flange Nut M3	18		
	Nut M3	17		
	Nut M2	1		

DRAWING OF PLASTIC PART PLACEMENT "CORVETTE HI-RIDER"

Ⓑ Block Part 1 pc.

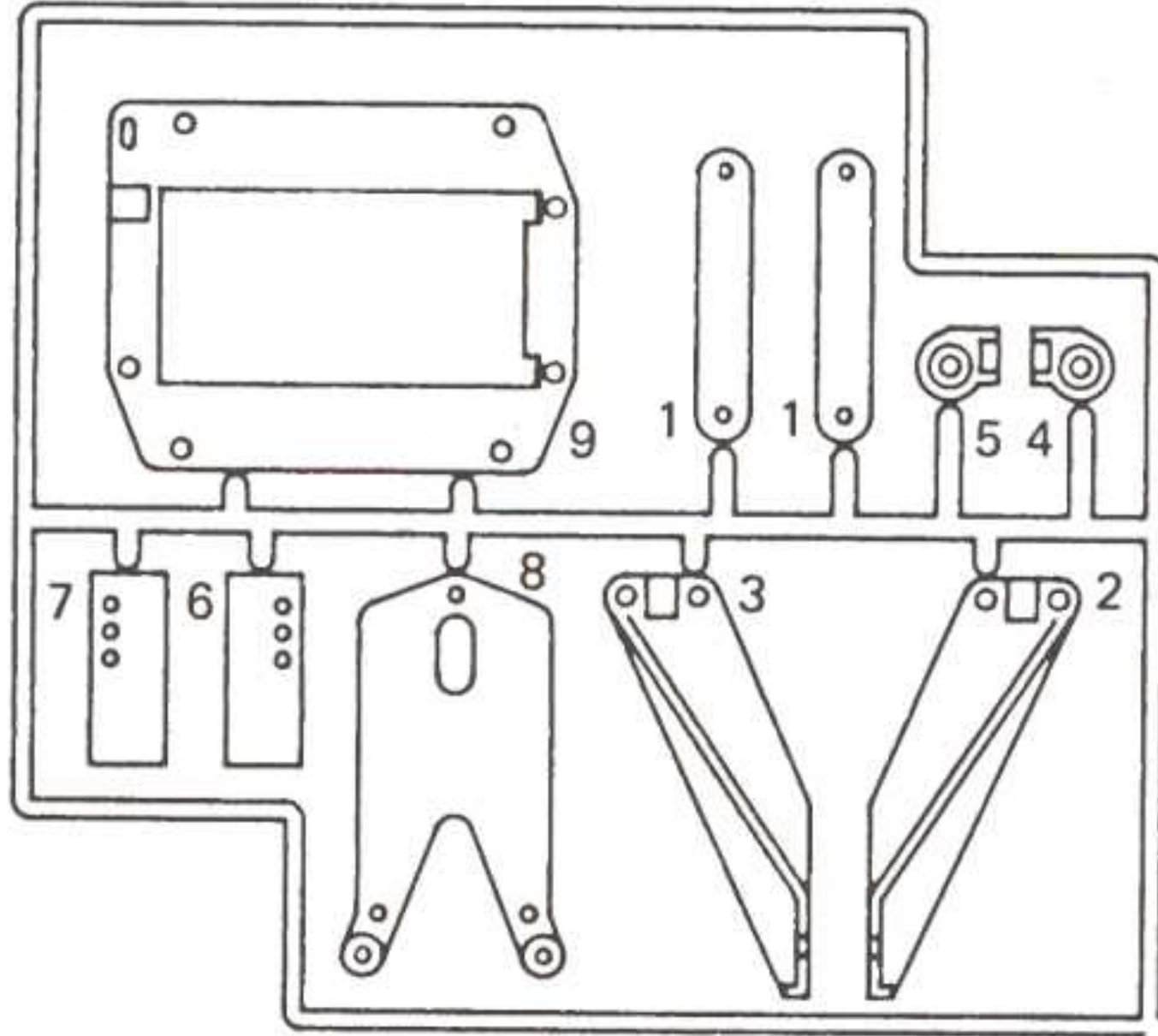

Ⓒ Block Parts 4 pcs.

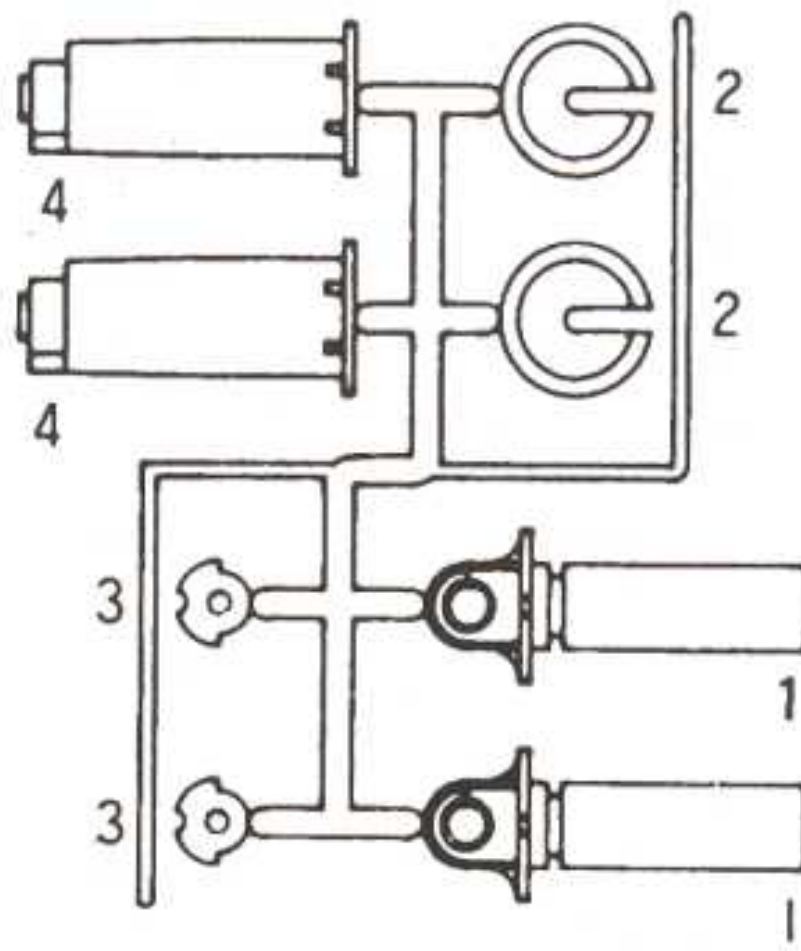

Ⓓ Block Part 1 pc.

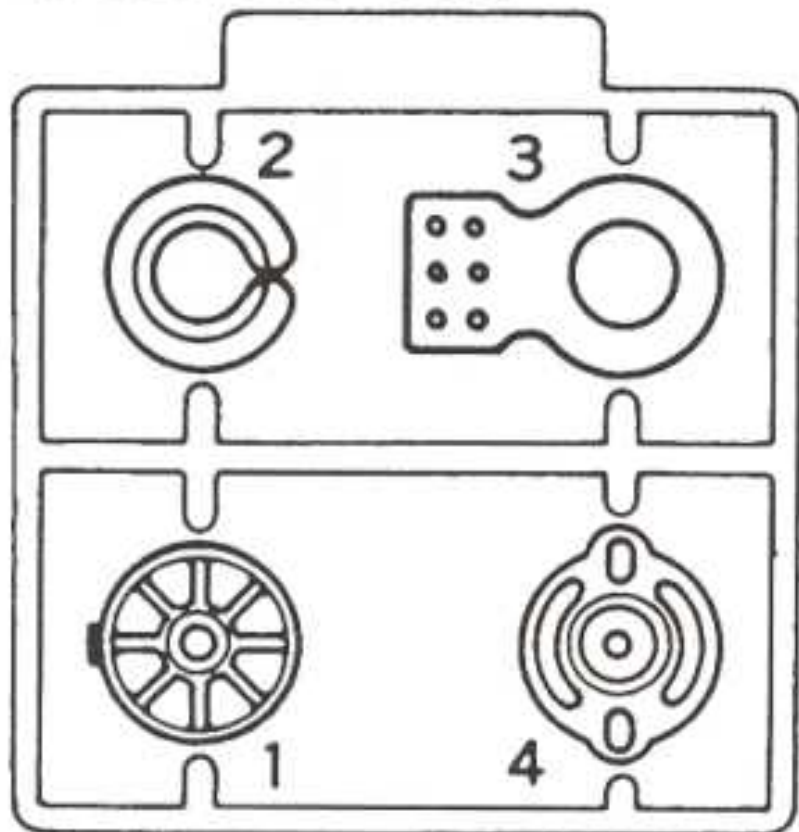

Ⓔ Block Part 1 pc.

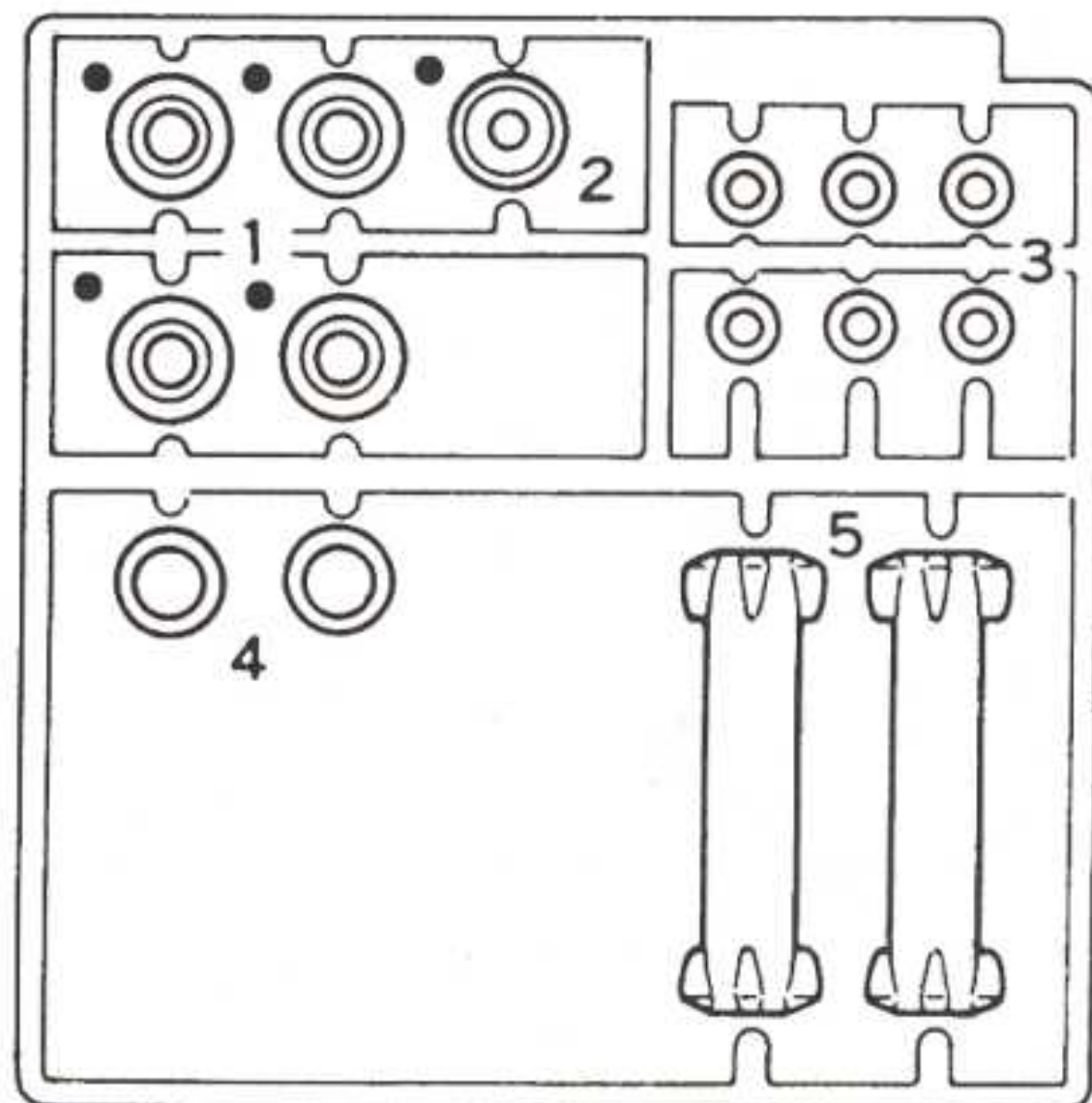

● These parts are not used.

1 ASSEMBLY OF GEARBOX

8 φ Washer...1

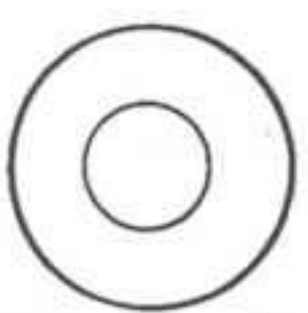

Idle Gear Shaft...1

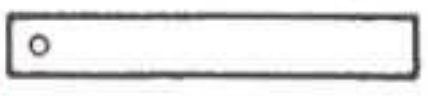

Differential Joint Shaft...1

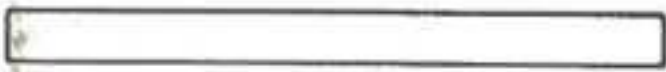

Idle Gear Shaft Pin...1

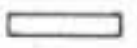

4 φ Plain Bearings...2

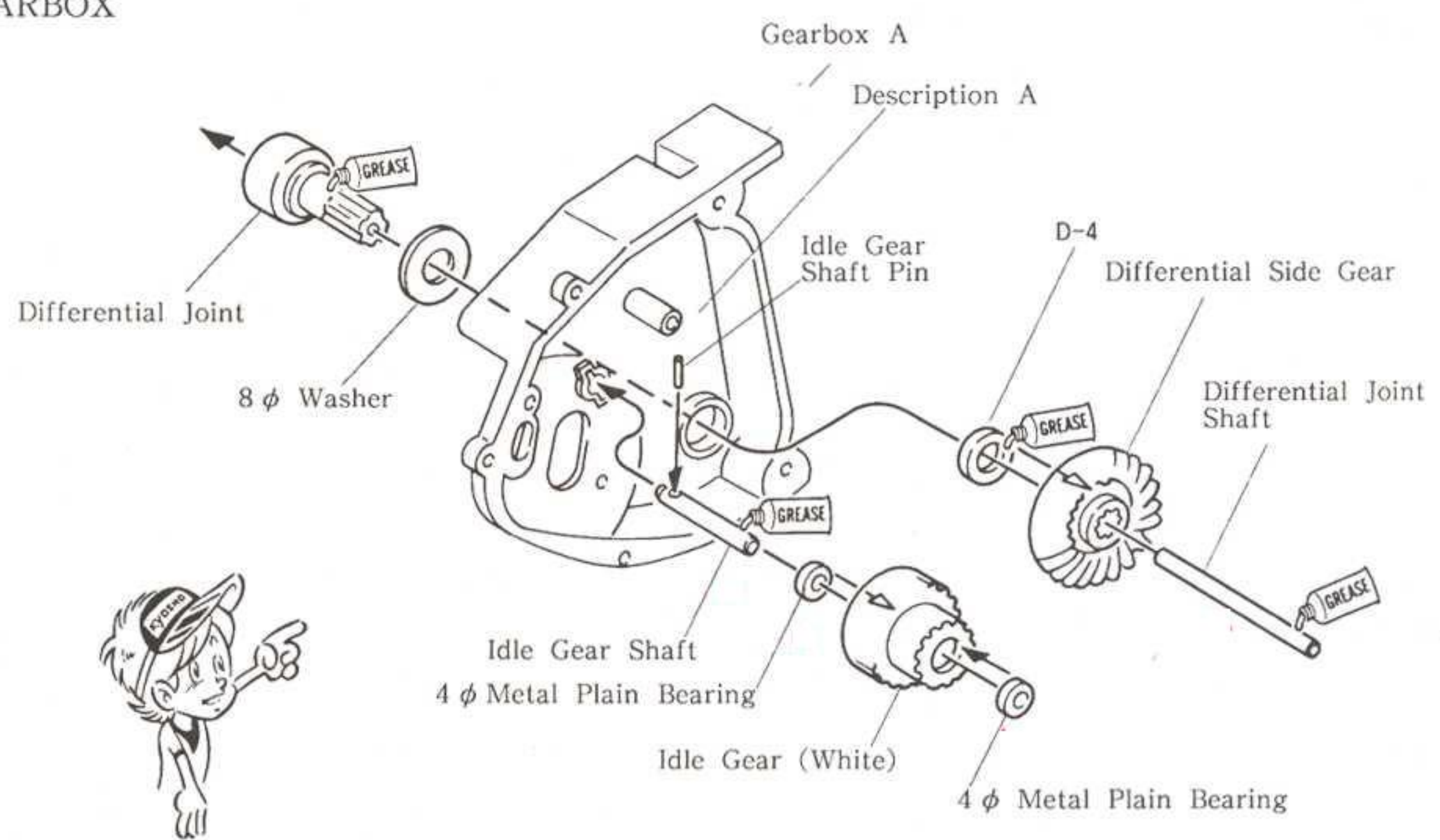

2 ASSEMBLY OF GEARBOX

M3x12 Self Tapping Screw

8 φ Washer...1



M3x12 TP Screws...4

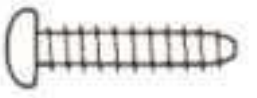

Counter Gear Shaft...1

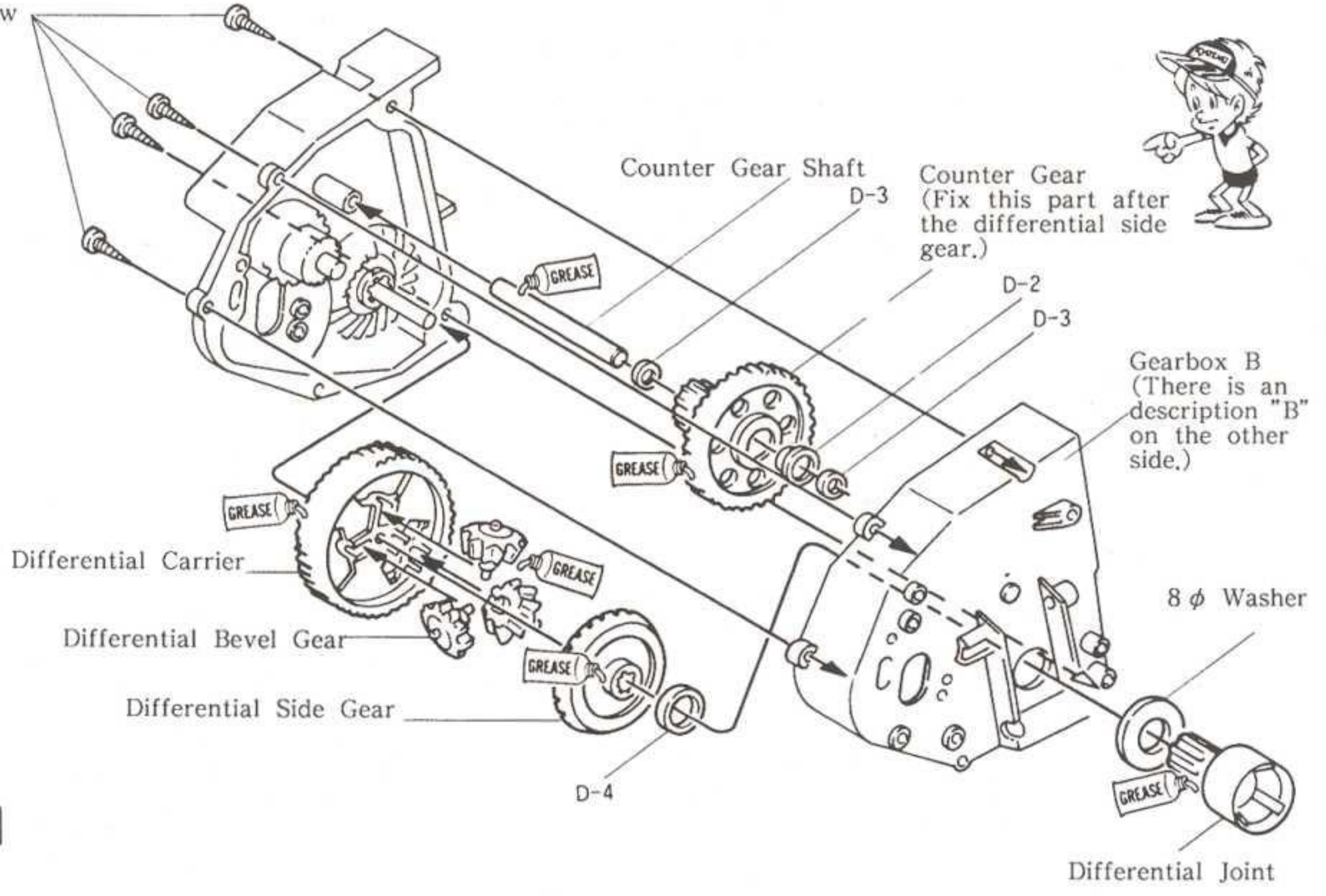

3 ASSEMBLY OF SUSPENSION ARM

M2x6 TP Screws...16

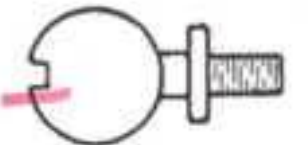

8 φ Pillow Balls...8

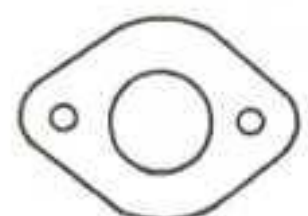

8 φ Ball Seats...8



5 φ Plastic Bearings...8

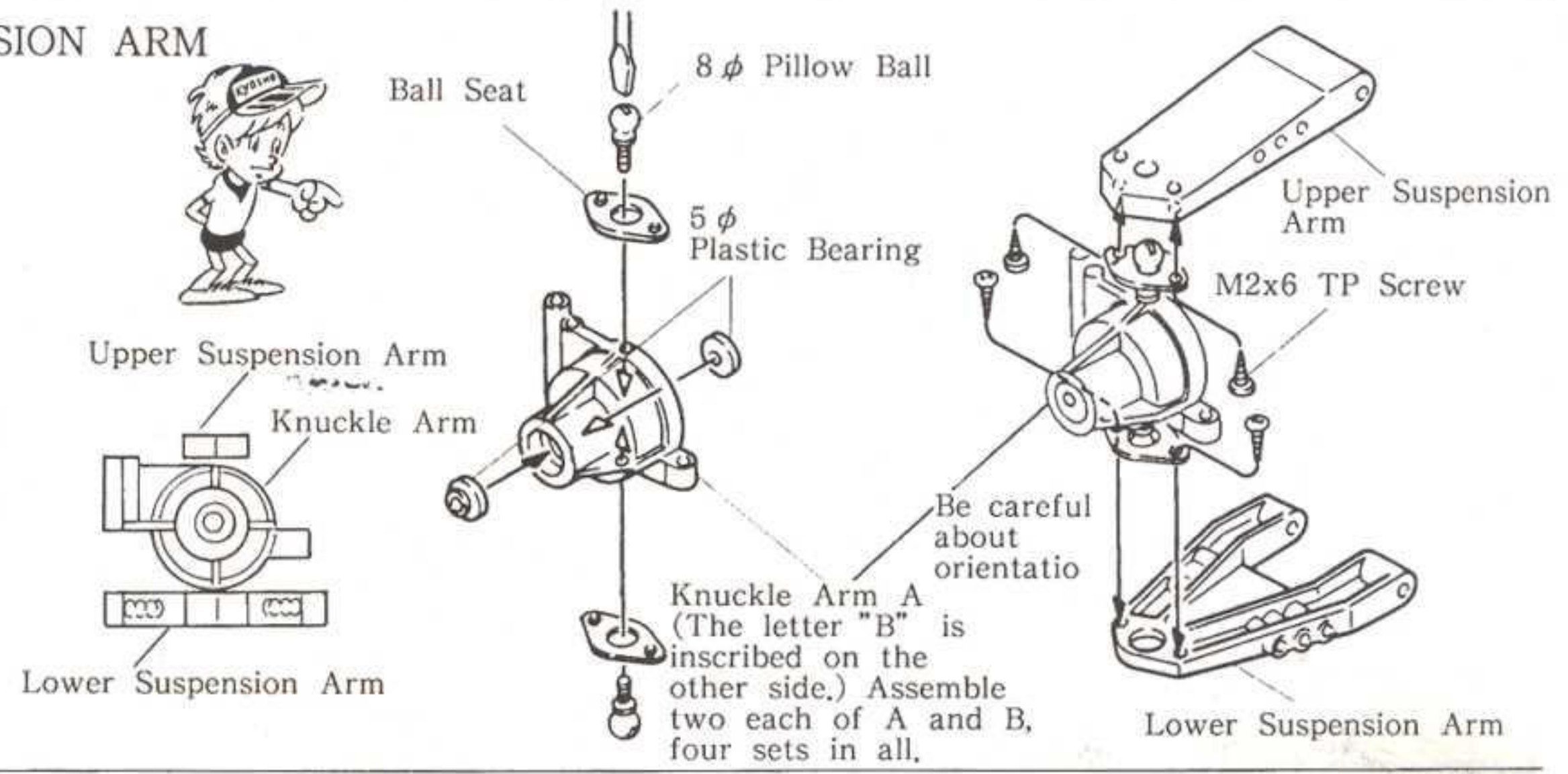

4 ASSEMBLY OF MAIN FRAME

M3x16 TP Screws...2

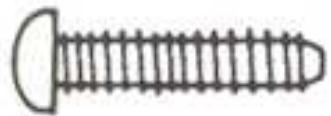

M3x12 TP Screws...8

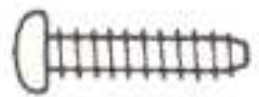

M3x12 Screws...2



3 φ Washers...4



M3 Flange Nuts...2



M3 Nuts...2



5.8 φ Pillow Balls...2



Pillow Ball Bases...2

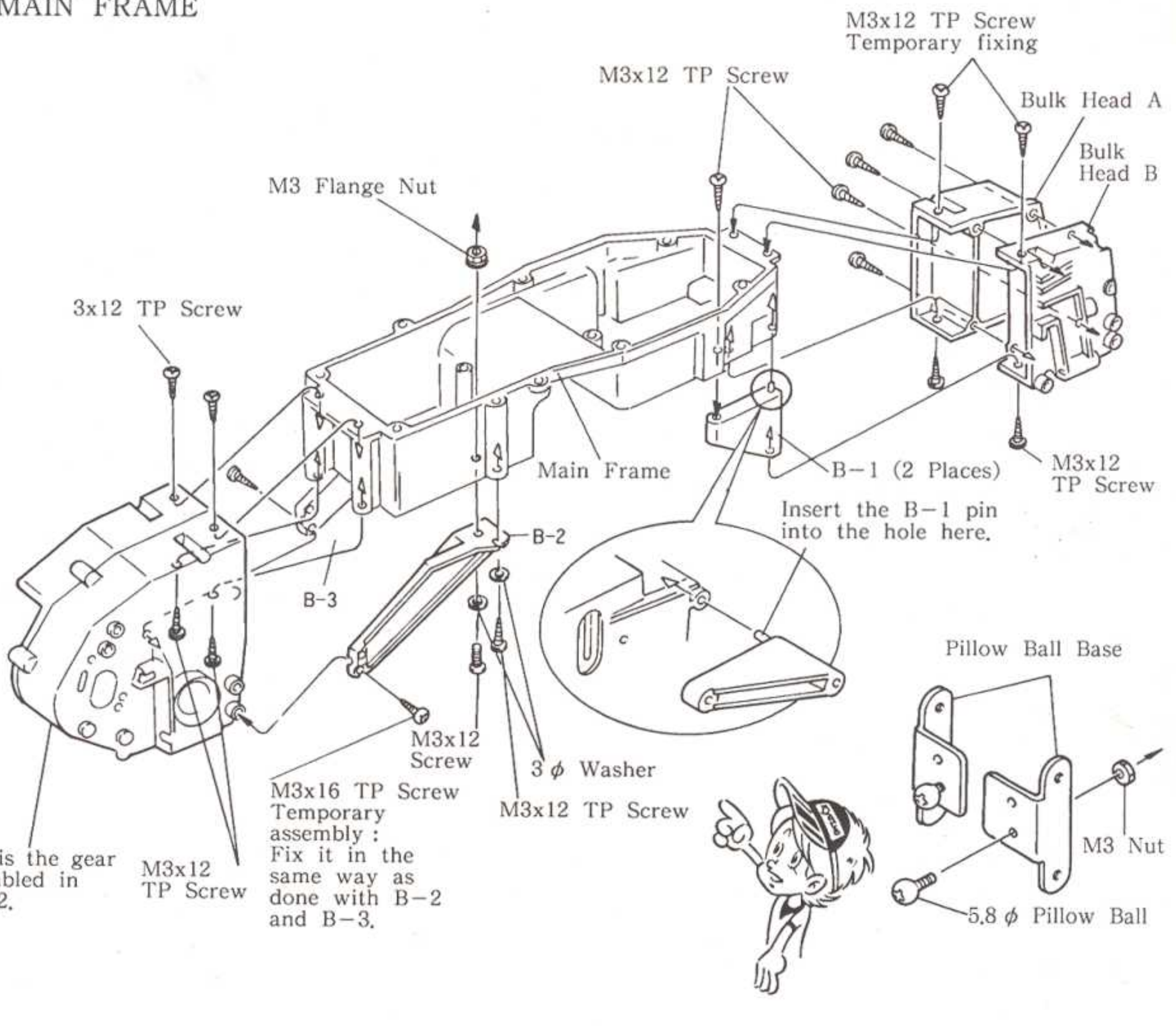
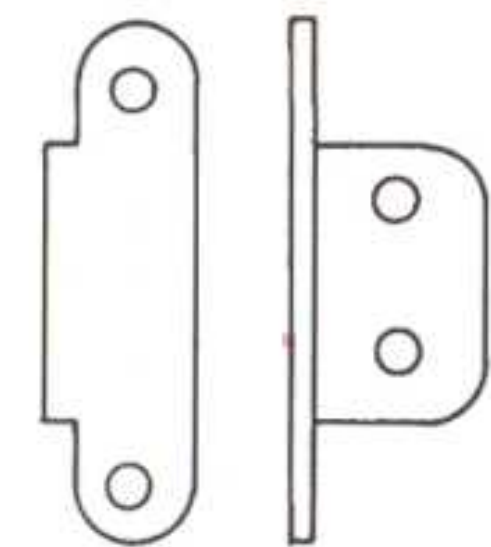

This is the gear assembled in step 2.

M3x12 TP Screw

M3x16 TP Screw Temporary assembly: Fix it in the same way as done with B-2 and B-3.

5 INSTALLATION OF SUSPENSION ARM

M3x16 TP Screws...4

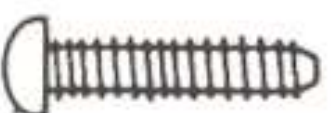

M3 Nuts...4



5.8 φ Pillow Balls...16

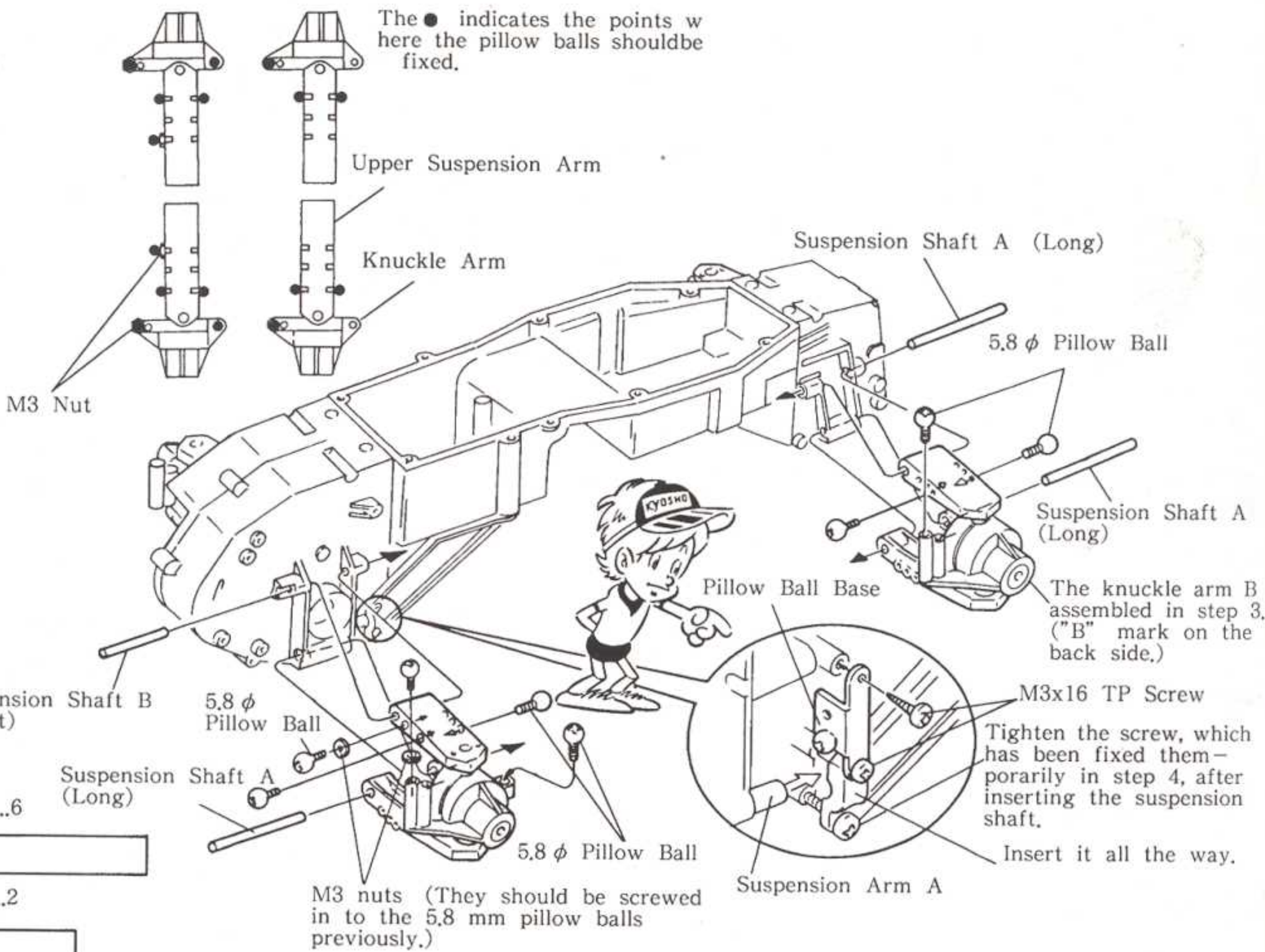

M3 Nut

Suspension Shaft B (Short)

Suspension Shaft A (Long)

Suspension Shafts A...6

Suspension Shafts B...2

M3 nuts (They should be screwed in to the 5.8 mm pillow balls previously.)

6 HOW TO CHECK RADIO SYSTEM

Operate the radio control units in order of the numerical figures.

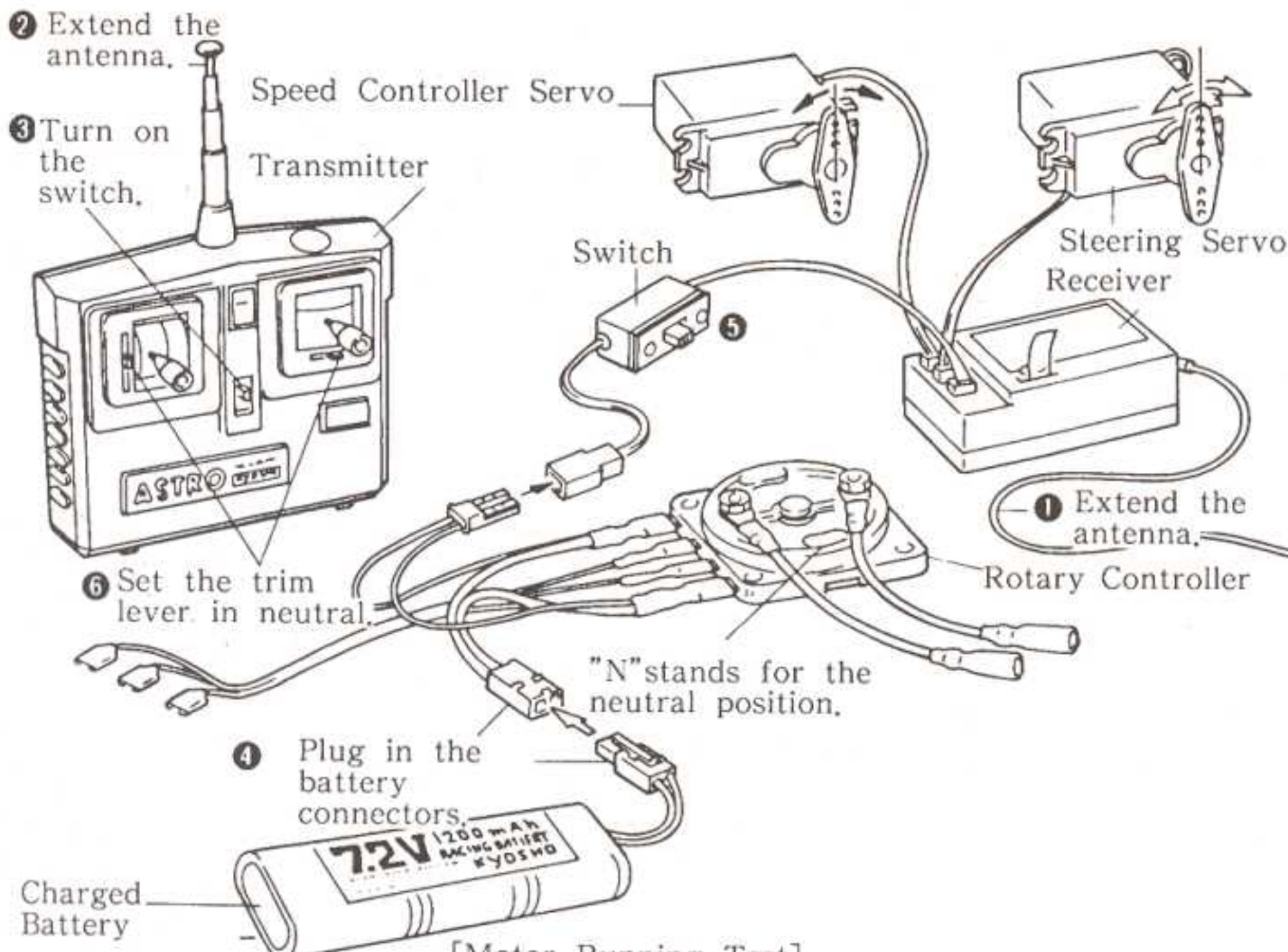

[Motor Running Test]
Before plugging in the battery connectors, confirm the speed controller is set in neutral.



This model is for BEC system radio only.

A two channel radio is composed of things like a transmitter, receiver, servos, and battery.

- Transmitter -- It is effect a control box. Signal waves are transmitted through an antenna according to the stick movements.
- Receiver ---- Receives the signals from the transmitter and send them to the servos.
- Servo ----- They really move the control mechanism of a model car in accordance with the signals from the receiver.
- Antenna ---- An antenna on the transmitter sends signals, and one on the receiver accepts them. They should be fully extended.
- Trim Lever -- They will adjust the neutral position of servos, thus regulate the steering and advancing controls finely.
- Battery ----- You can tell the amount of electricity in a battery and how the signals are emitted.
- Servo Horn --- They are intermediate devices on the servos to activate the controls. There are several types in shape. They should be selected depending upon the usage.

When switch on the radio...
Get the switches in order from transmitter to receiver.

When switch off the radio...
In order from receiver to transmitter.

7 ASSEMBLY OF SPEED CONTROL SERVO

[Actual Size]

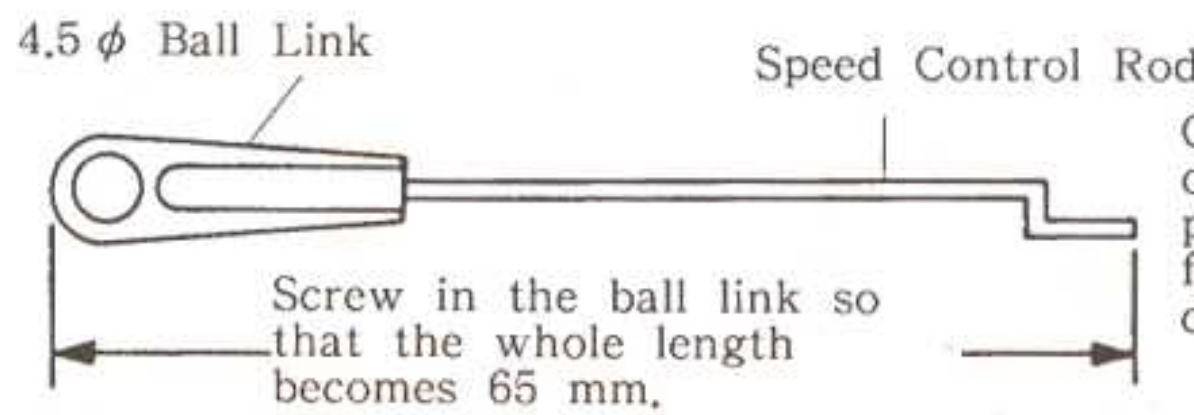
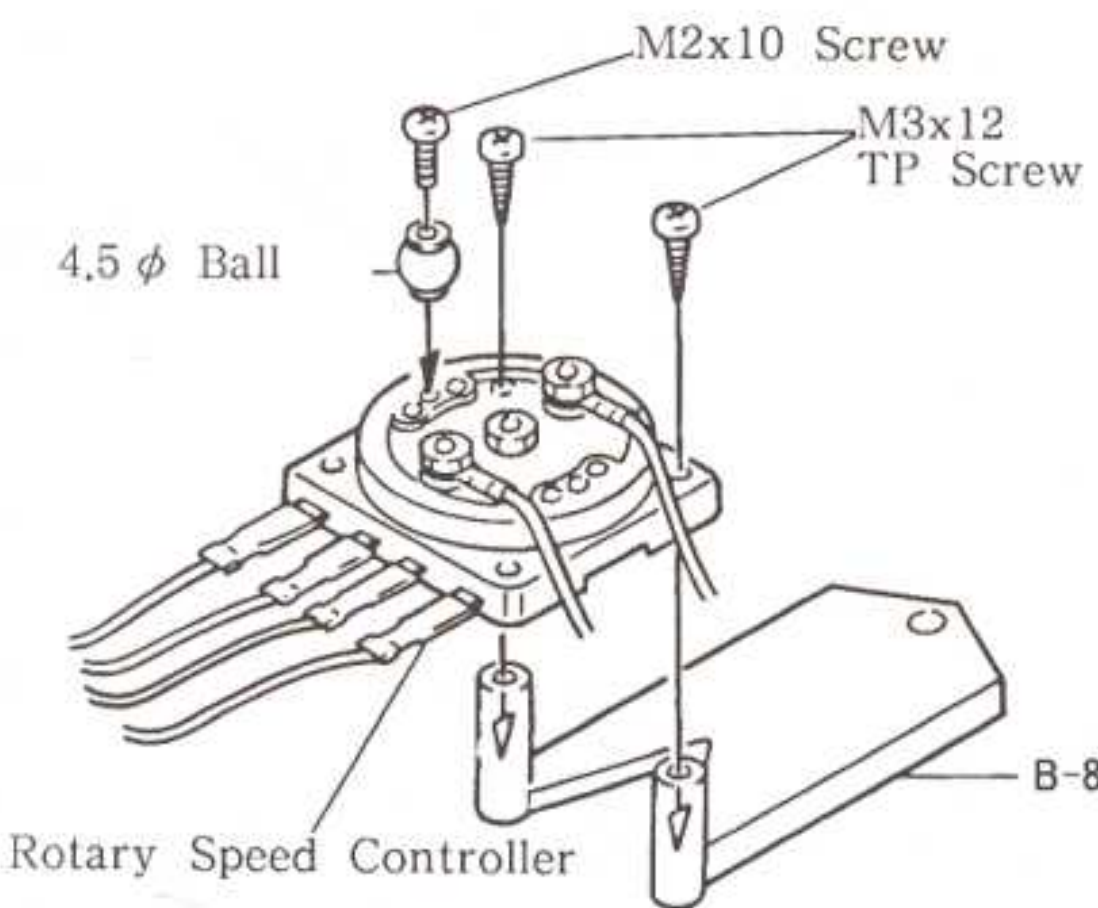

Trim the arm into the shape as shown.

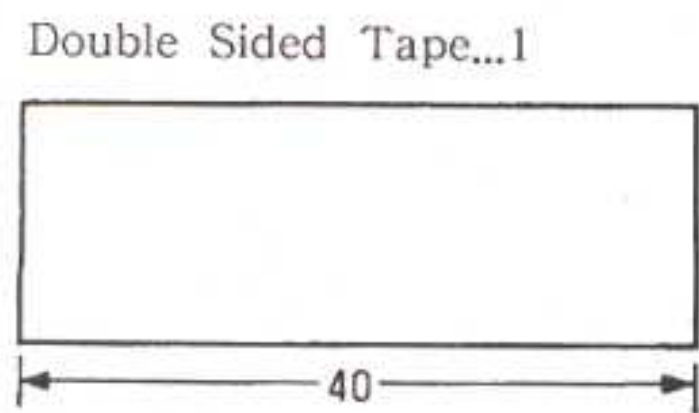
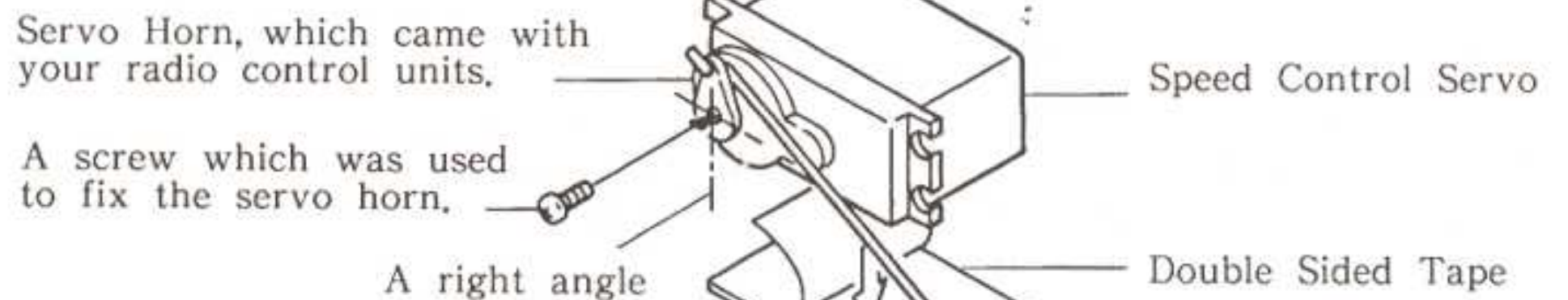
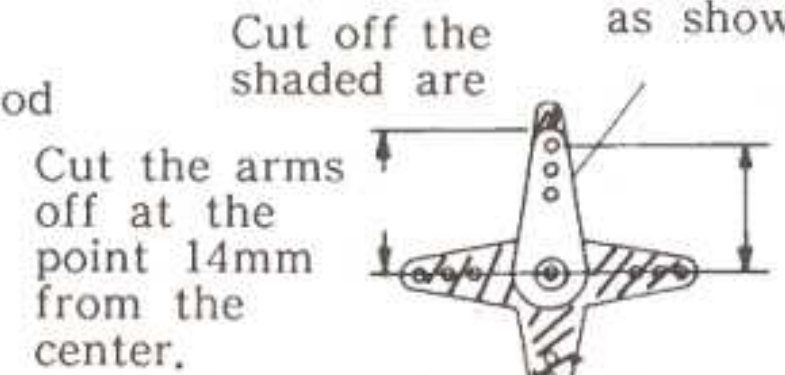

Double Sided Tape...1

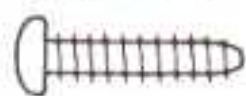

M3x12 TP Screws...2



M2x10 Screw...1



4.5 phi Ball...1

4.5 phi Ball Link...1



Speed Control Rod...1

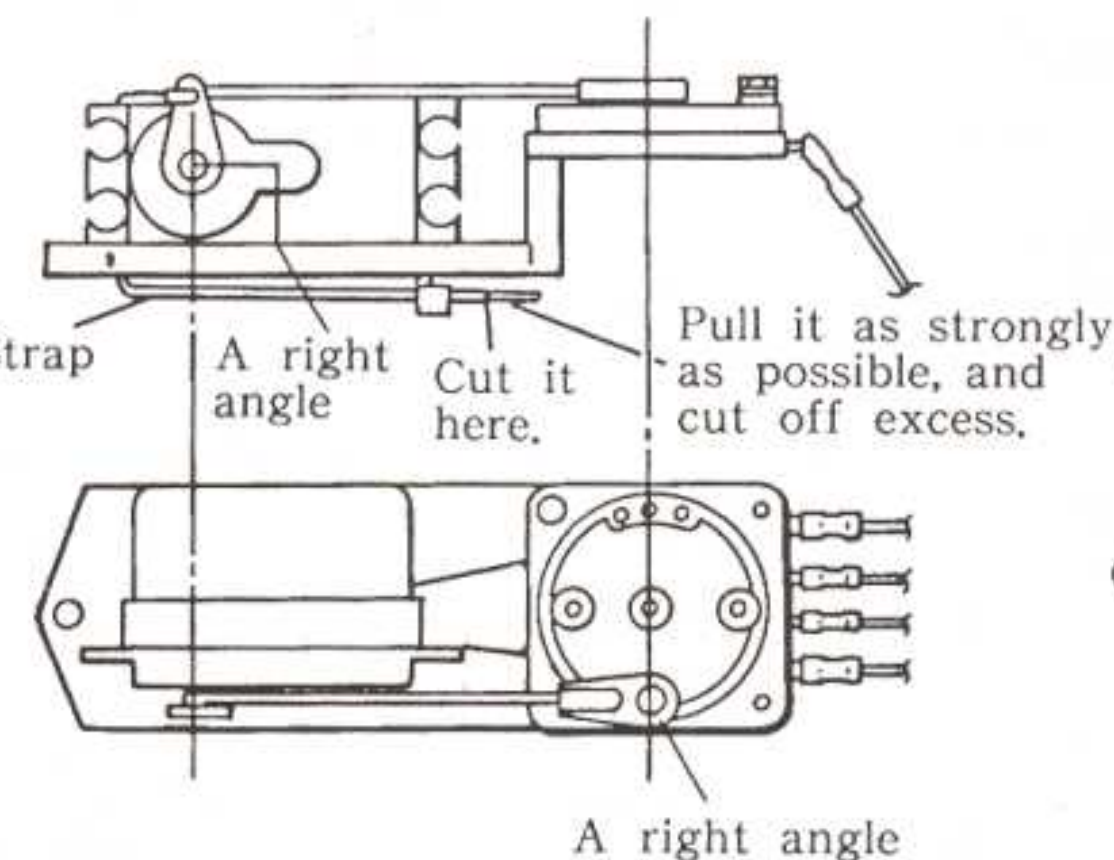
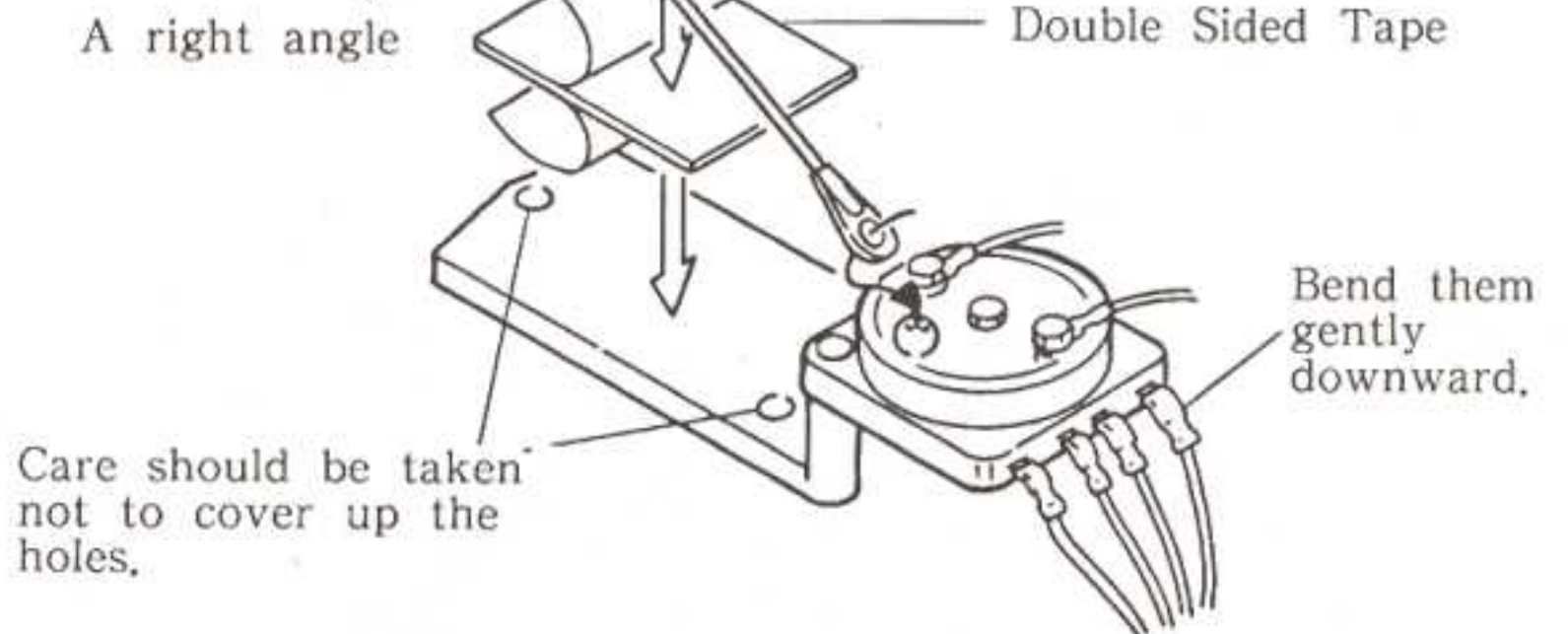

8 ASSEMBLY OF STEERING SERVO

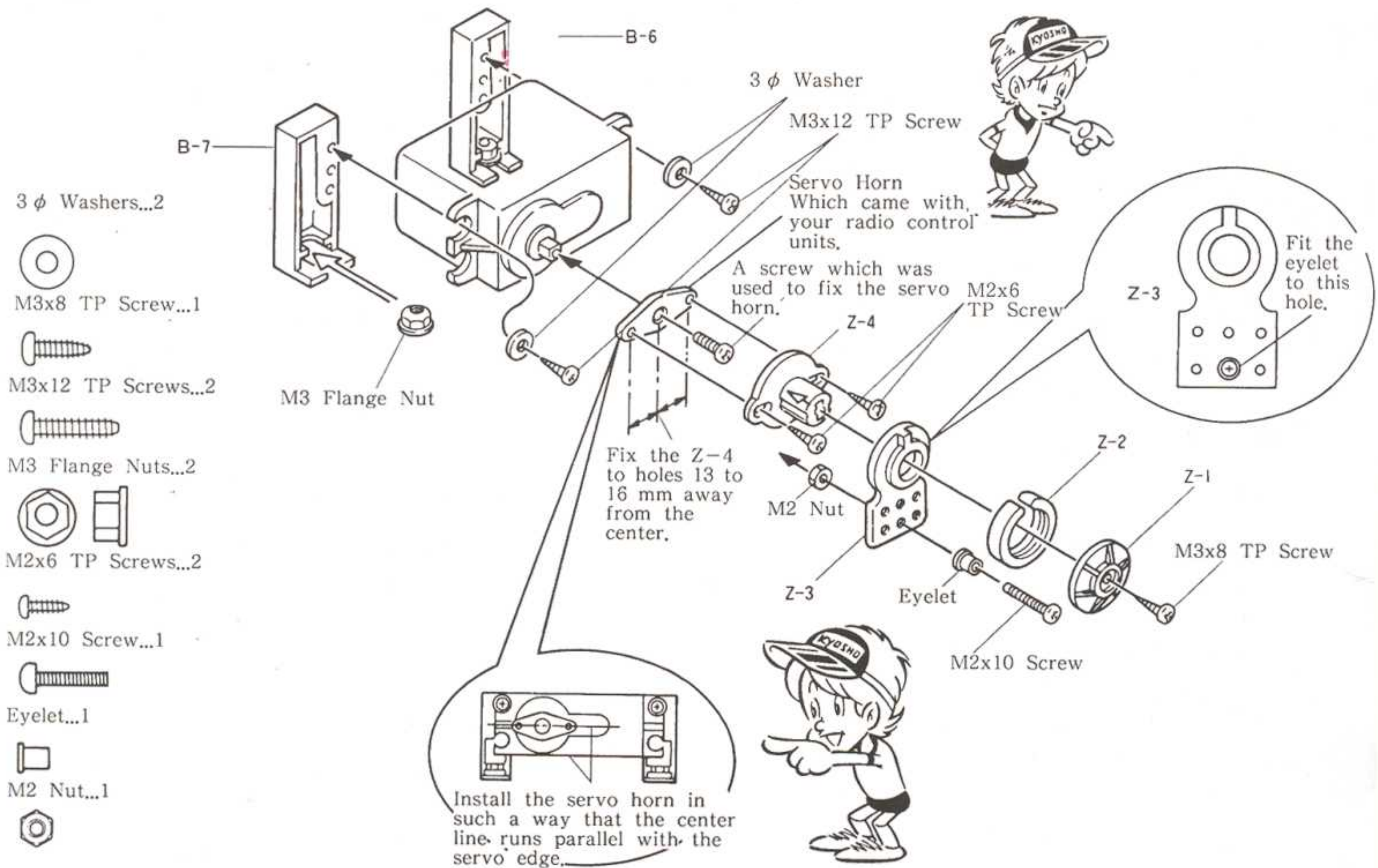

9 ASSEMBLY OF STEERING

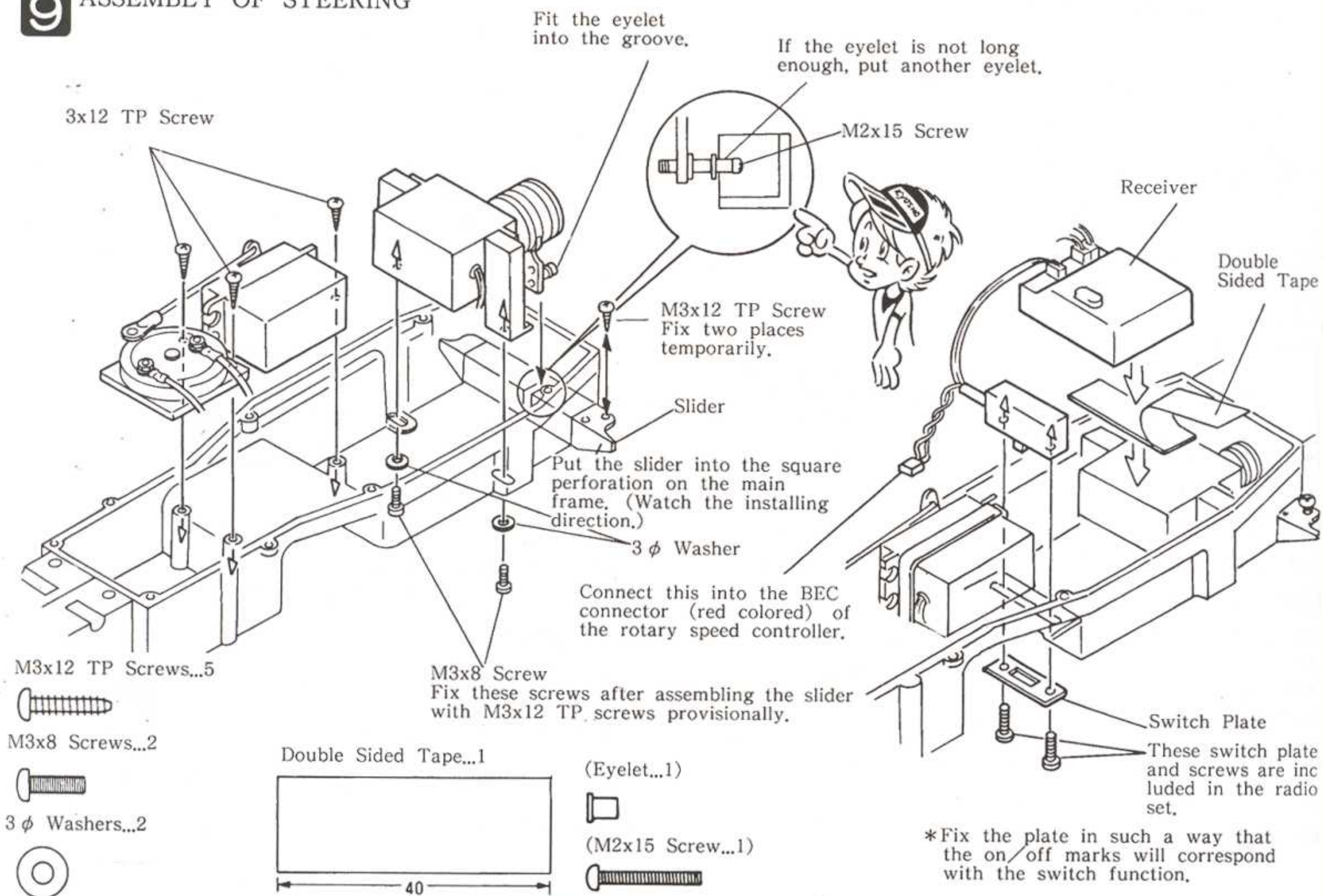

10 INSTALLATION OF TIE ROD

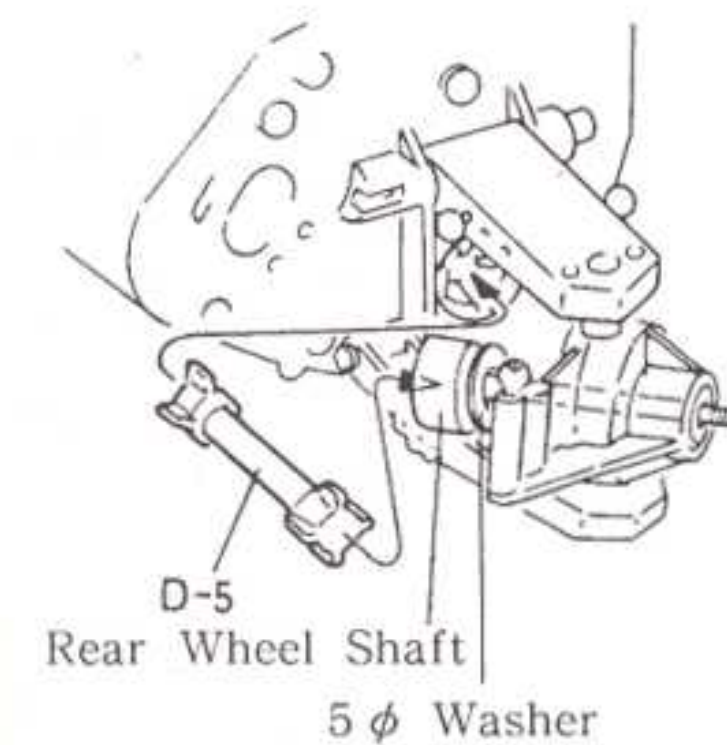

If you have any difficulty to install the D-5, remove the suspension shaft A once.

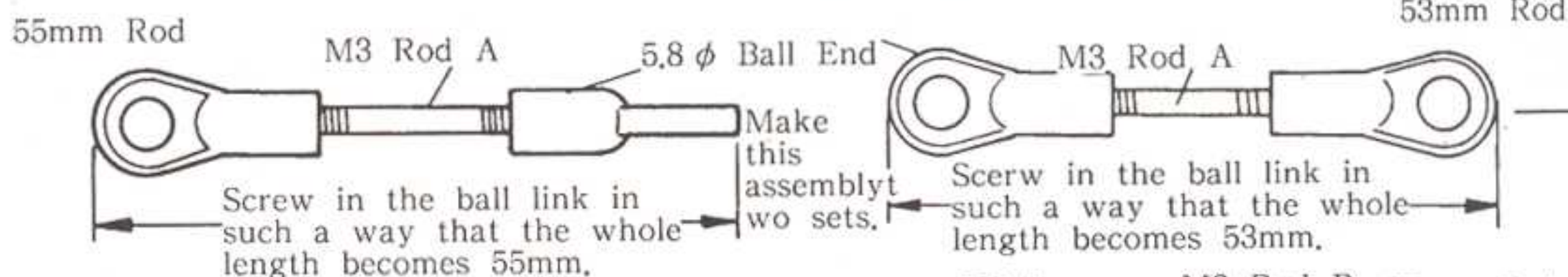
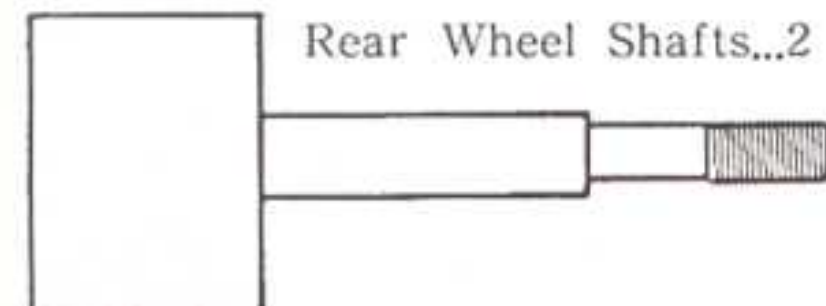
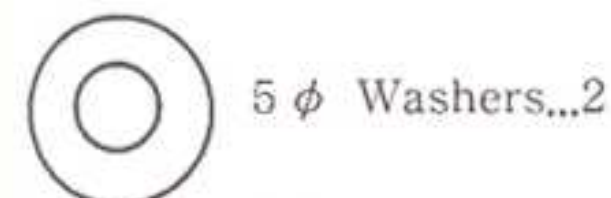

Take off the screw which has been fixed temporarily in step 9.

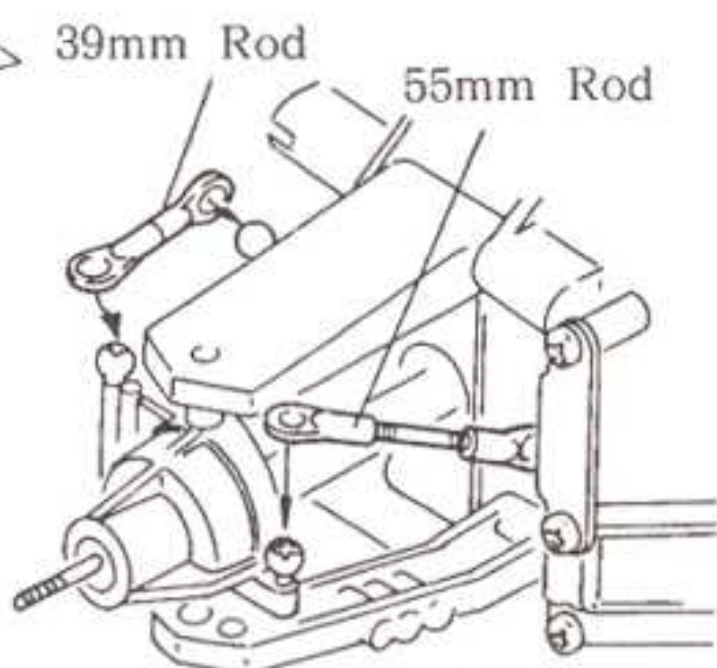

Assemble this portion for the right and left sides.

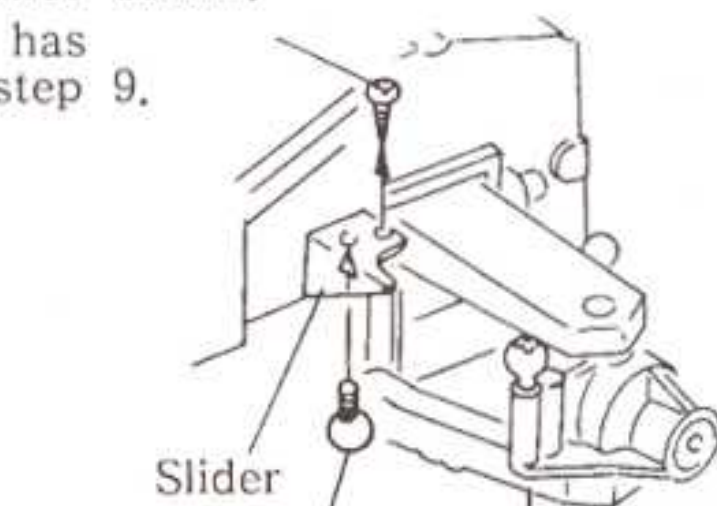

Fix it here.

Knuckle Collar

M3x28 TP Screw

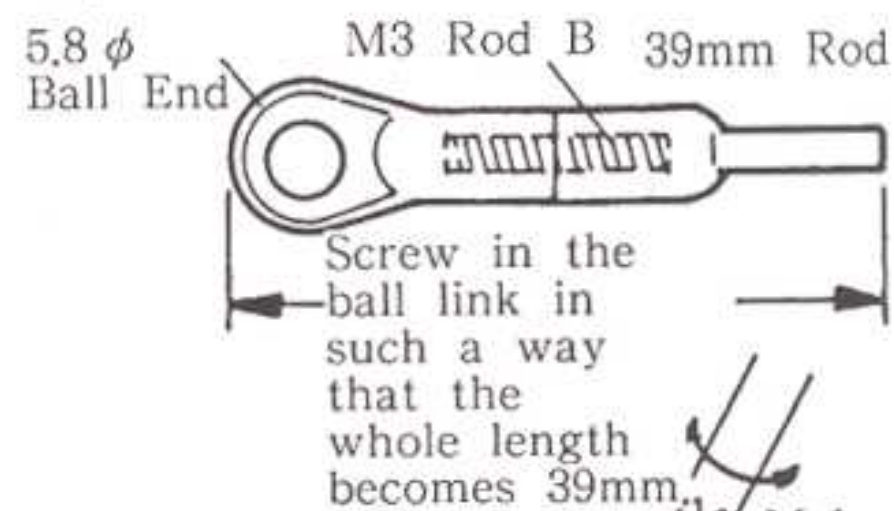
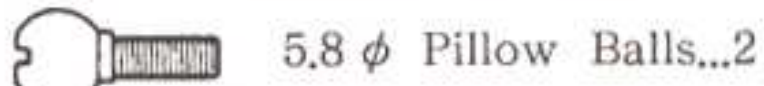

Assemble this portion for the right and left sides.
53mm Rod
You may be able to fix a control rod easily by enlarging the hole of a ball link.



11 ASSEMBLY OF FRONT GUARD

M3x16 TP Screw

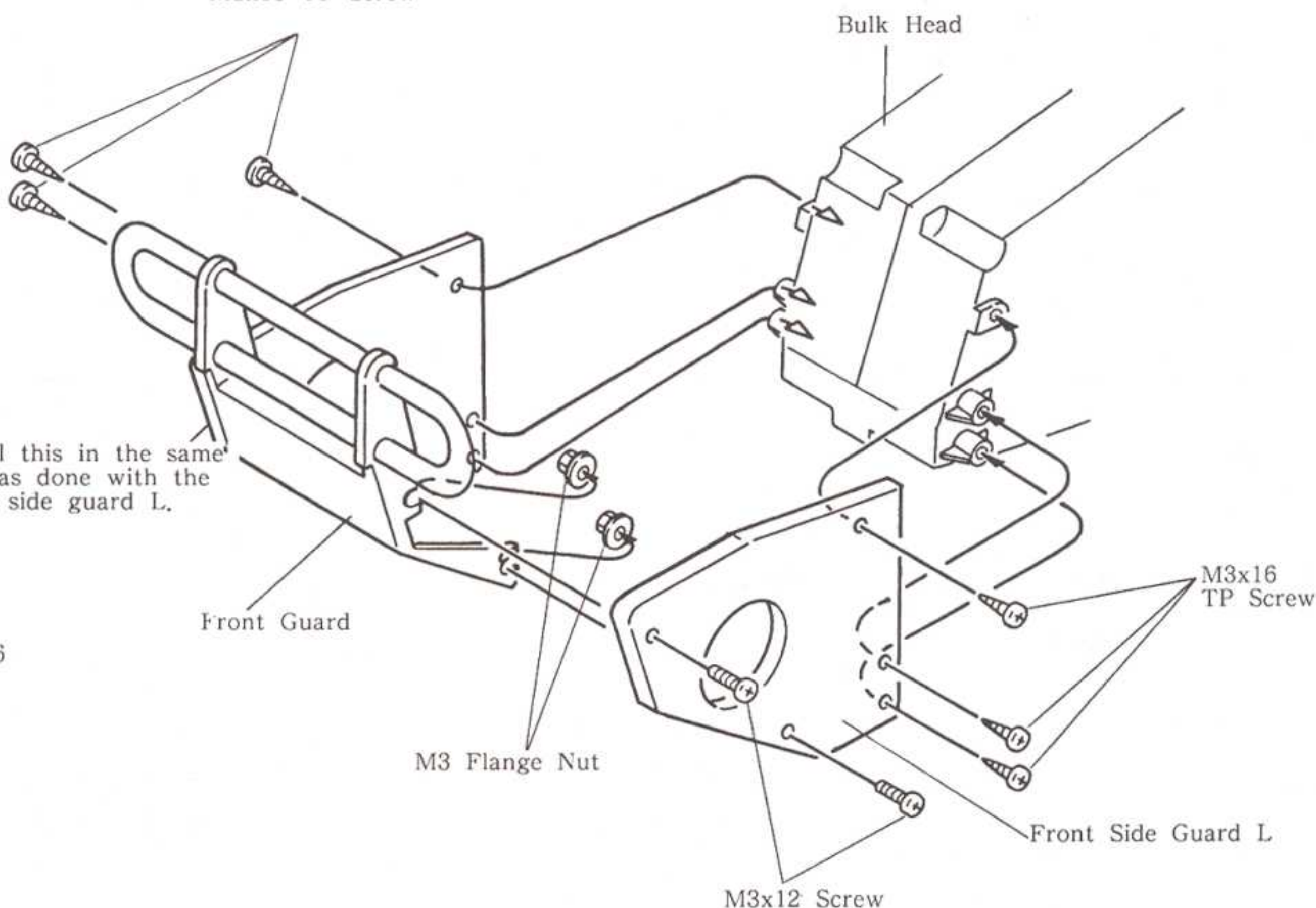

Install this in the same way as done with the front side guard L.

M3x16 TP Screws...6

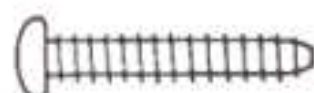

M3x12 Screws...4

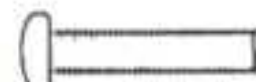

M3 Flange Nuts...4



12 INSTALLATION OF REAR GUARD

M3x60 Screw...1



M3x12 TP Screws...8

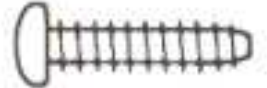

M3 Nylon Nut...1



*This is the gearbox for the end where the rotary speed controller is.

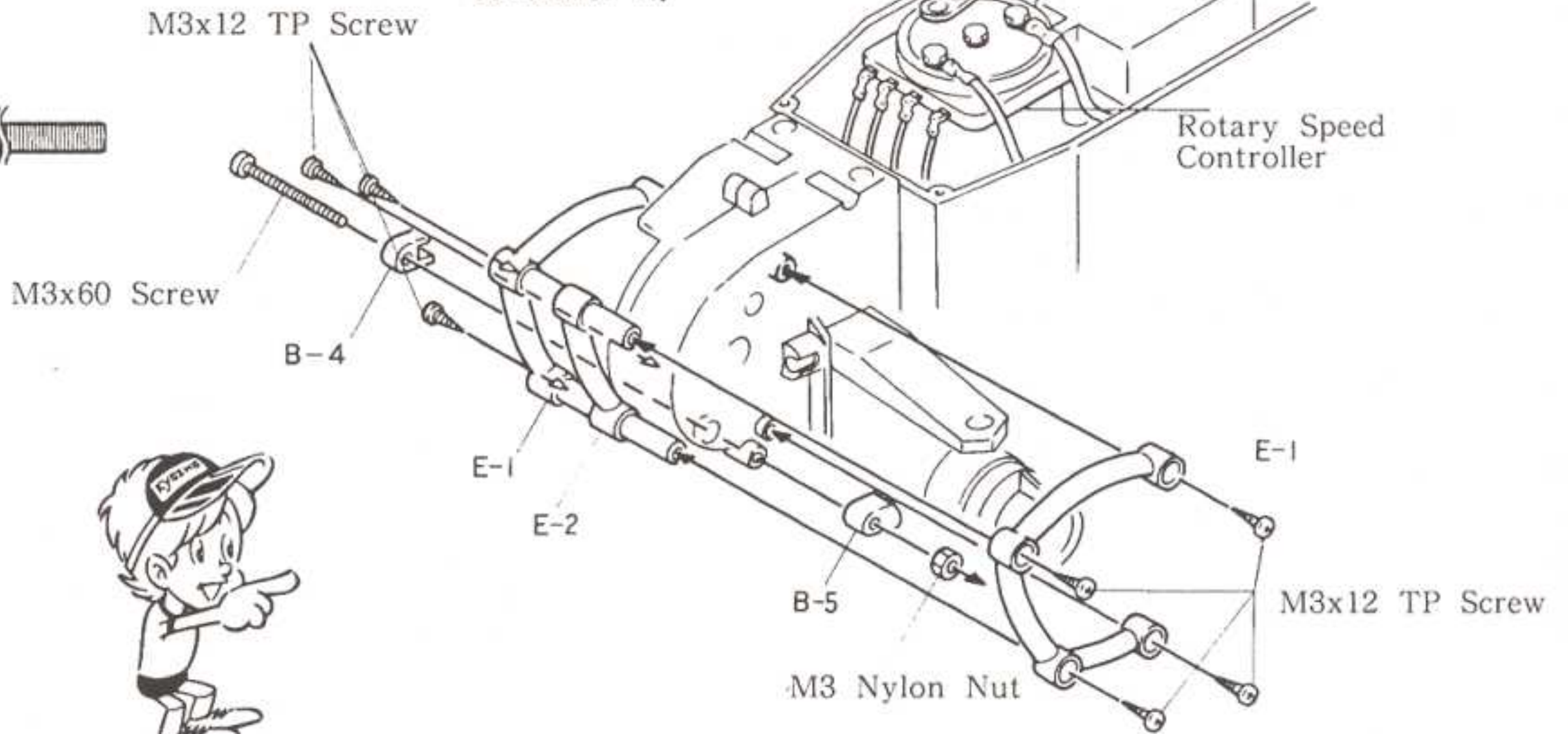

13 ASSEMBLY OF SHOCK

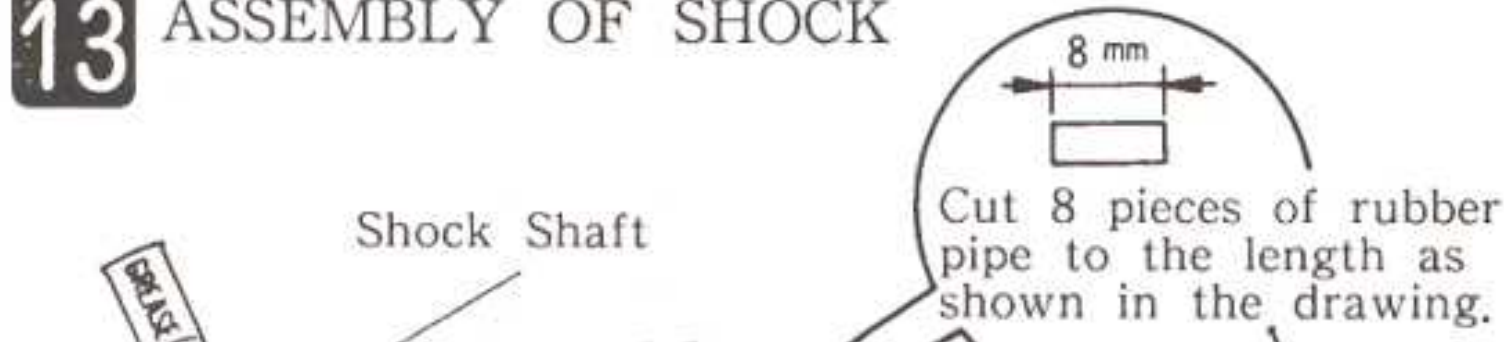

M2x6 TP Screws...16

Cut out rubber pipe as shown in the illustrations, ...4

Shock Shafts...8

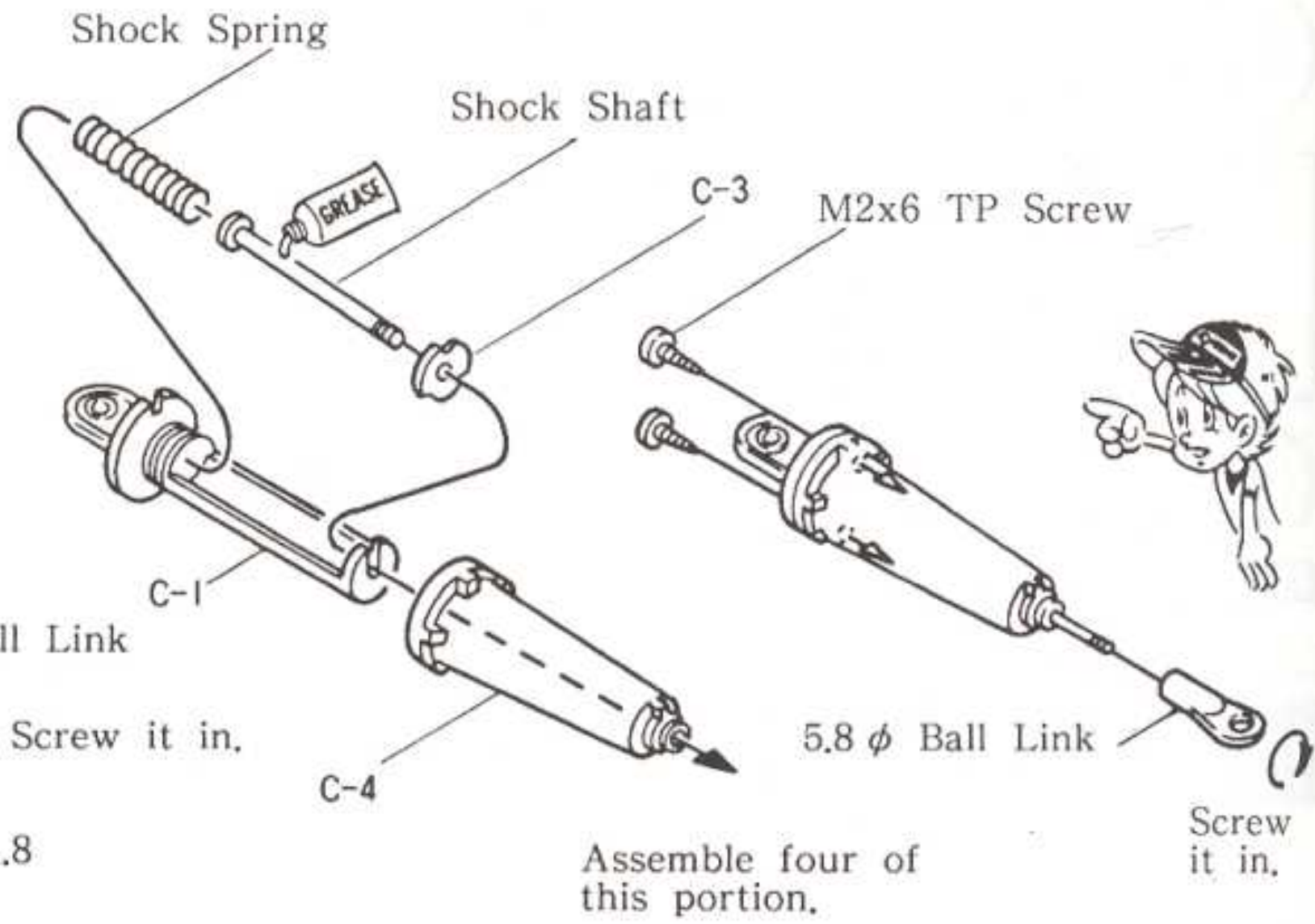

5.8 φ Ball Links...8

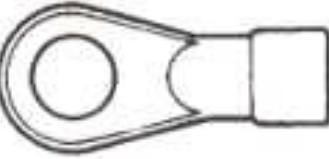

14 INSTALLATION OF SHOCK

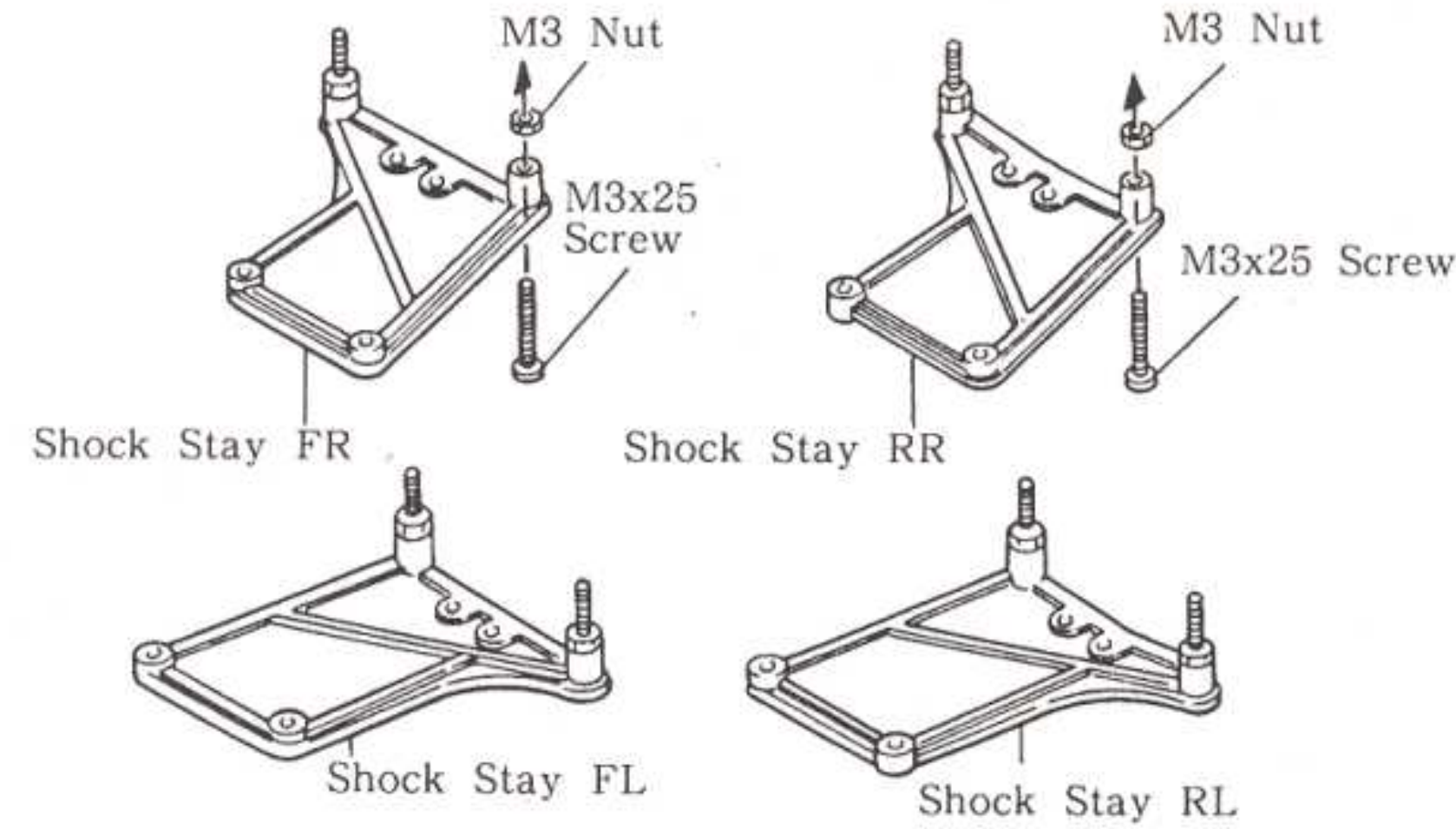

M3x15 TP Screws...6

M3 Nuts...8

M3 Flange Nuts...2



M3x12 Screws...2



M3x25 Screws...8

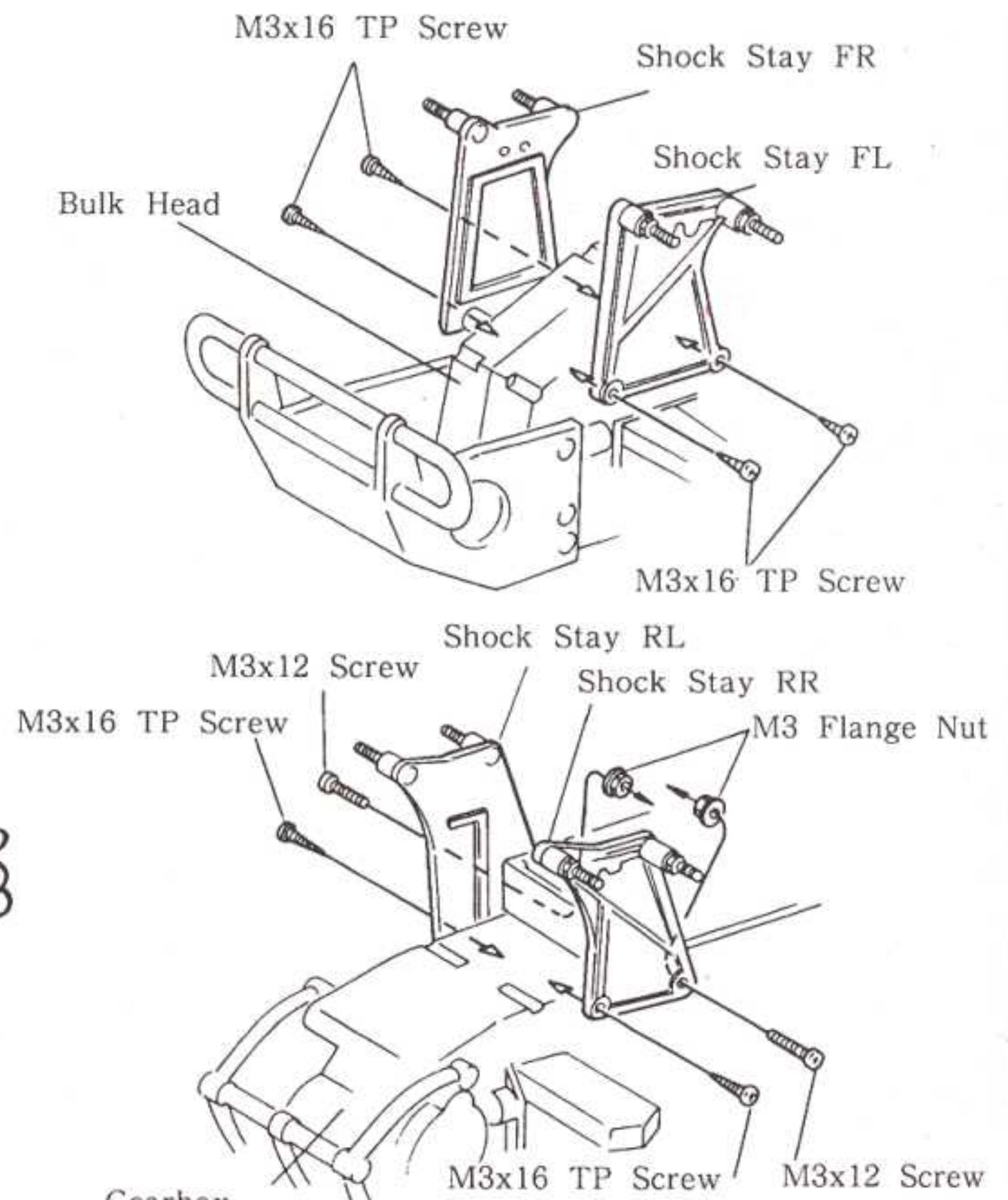

15 INSTALLATION OF SHOCK



Short shock with a buffer rubber assembled in step 13.

Long shock with a buffer spring assembled in step 13.

Cut off the rubber pipe to the length as shown.

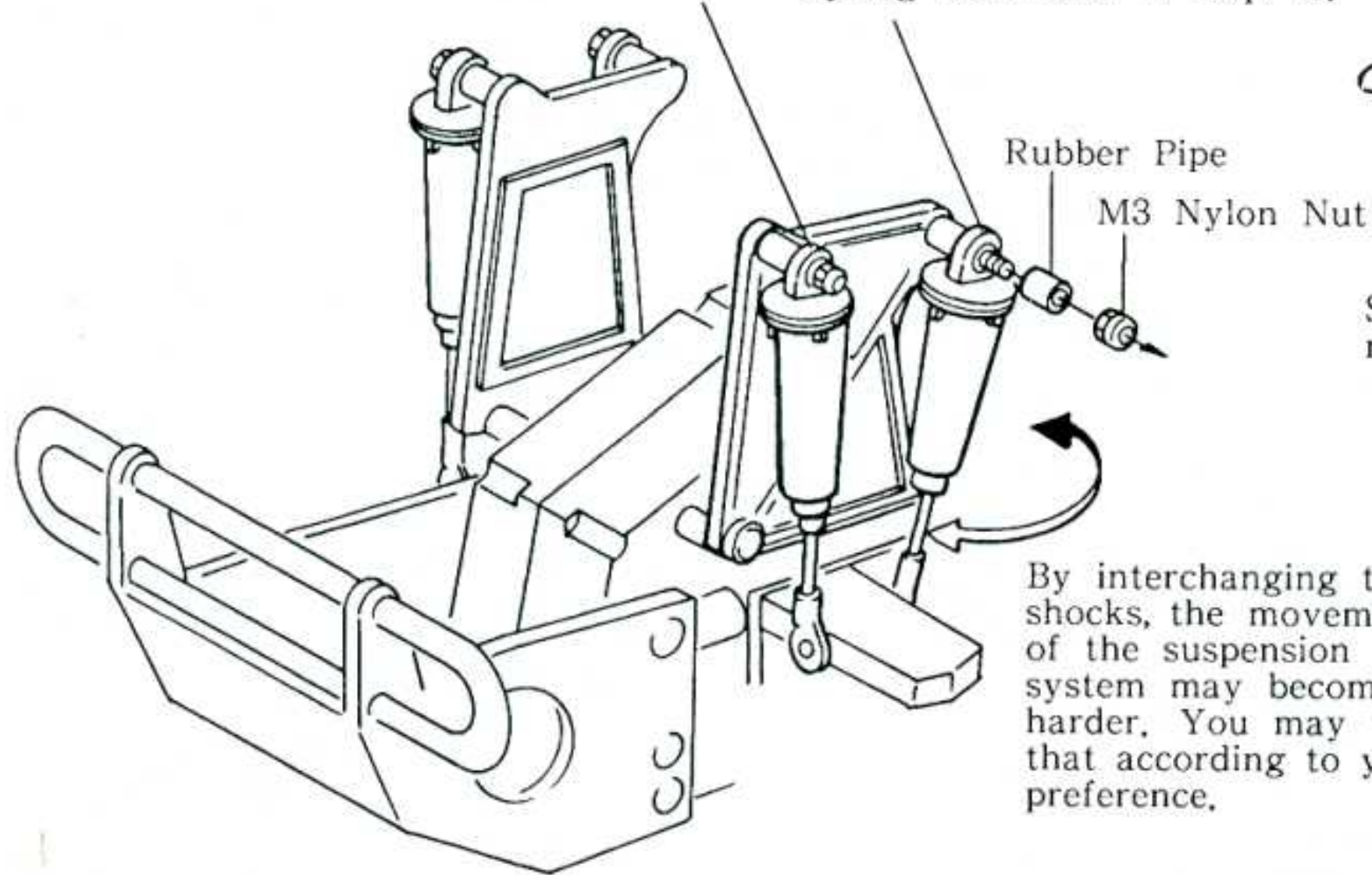
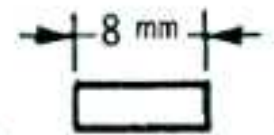

Long shock with a buffer spring assembled in step 13.

Short shock with a buffer rubber assembled in step 13.

By interchanging the shocks, the movement of the suspension system may become harder. You may try that according to your preference.

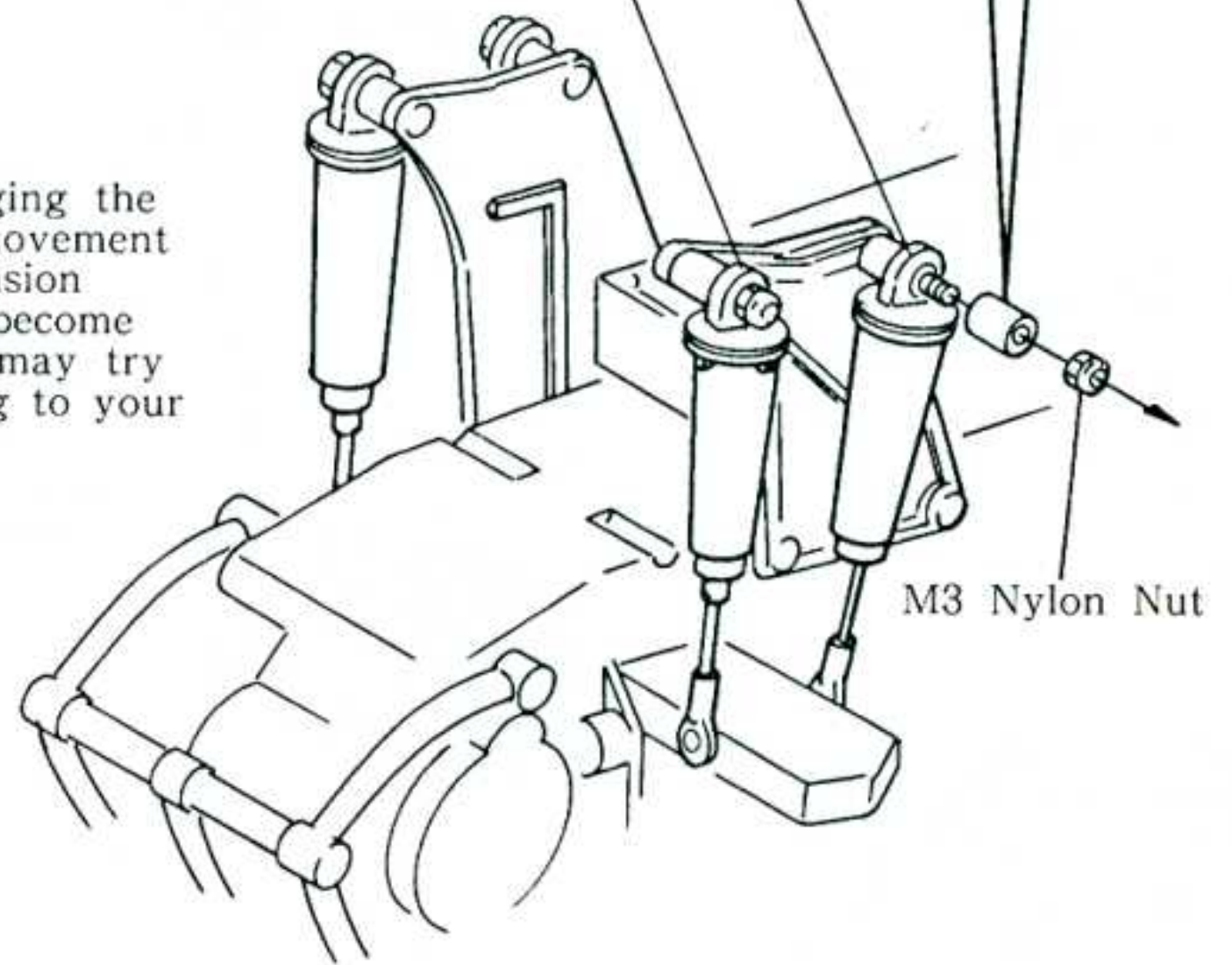

M3 Nylon Nuts...8



Rubber Pipes...8

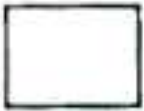

16 INSTALLATION OF BATTERY GUARD



This is the end where the gearbox is installed (Rear)

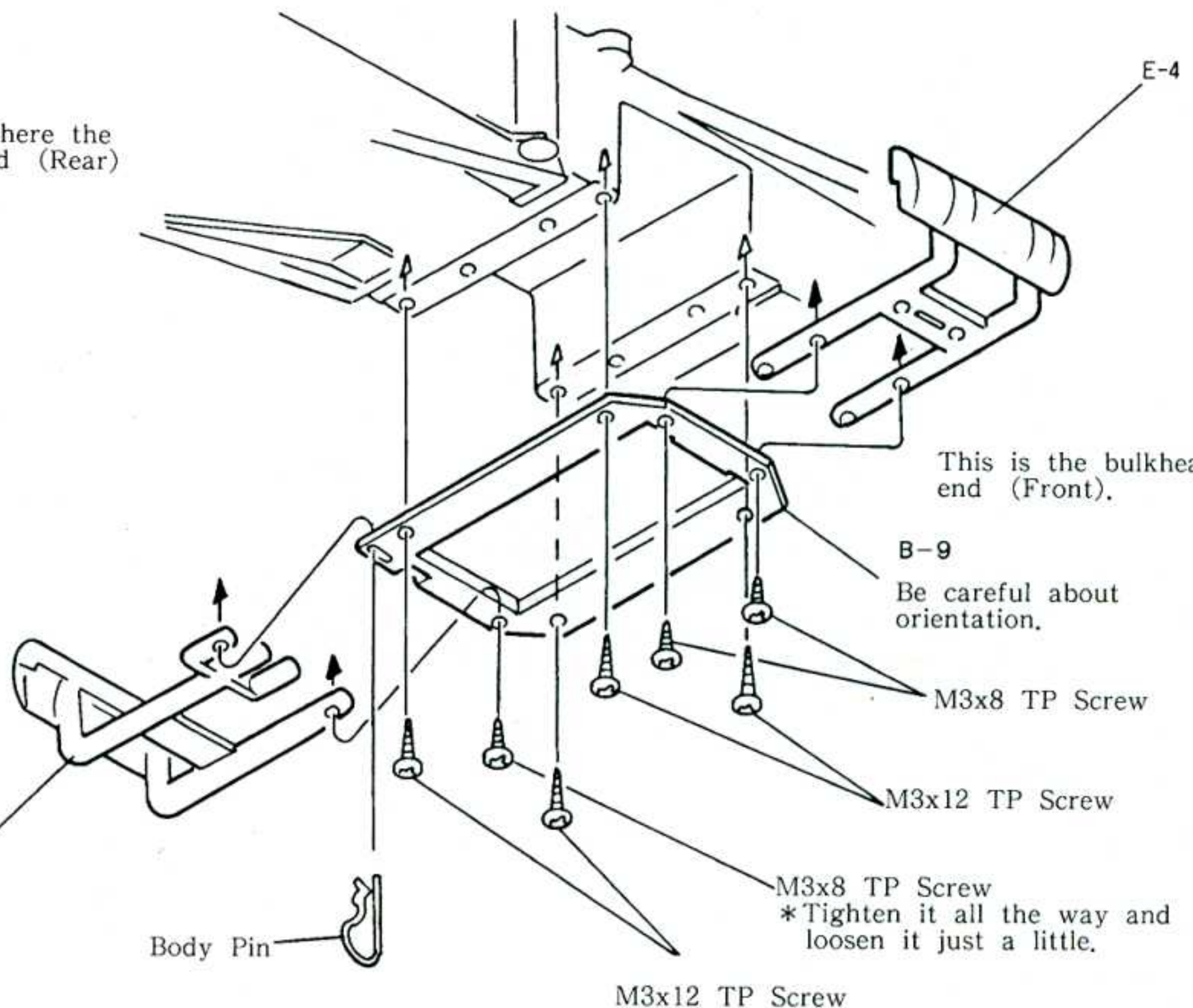

This is the bulkhead end (Front).

B-9
Be careful about orientation.

M3x8 TP Screw
*Tighten it all the way and loosen it just a little.

M3x12 TP Screws...4

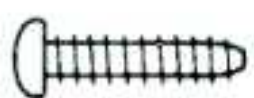

M3x8 TP Screws...3

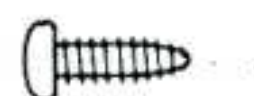

Body Pin...1

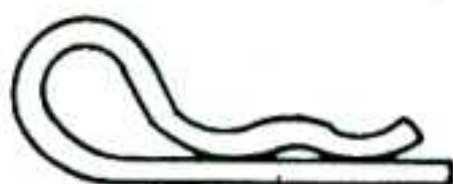

17 INSTALLATION OF MOTOR

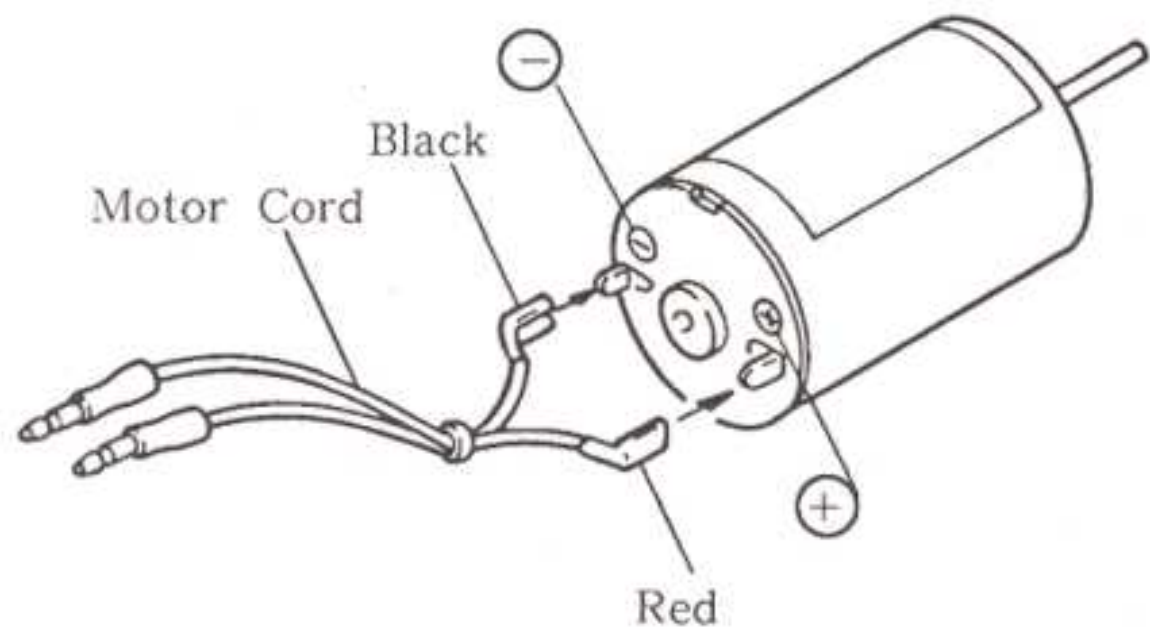
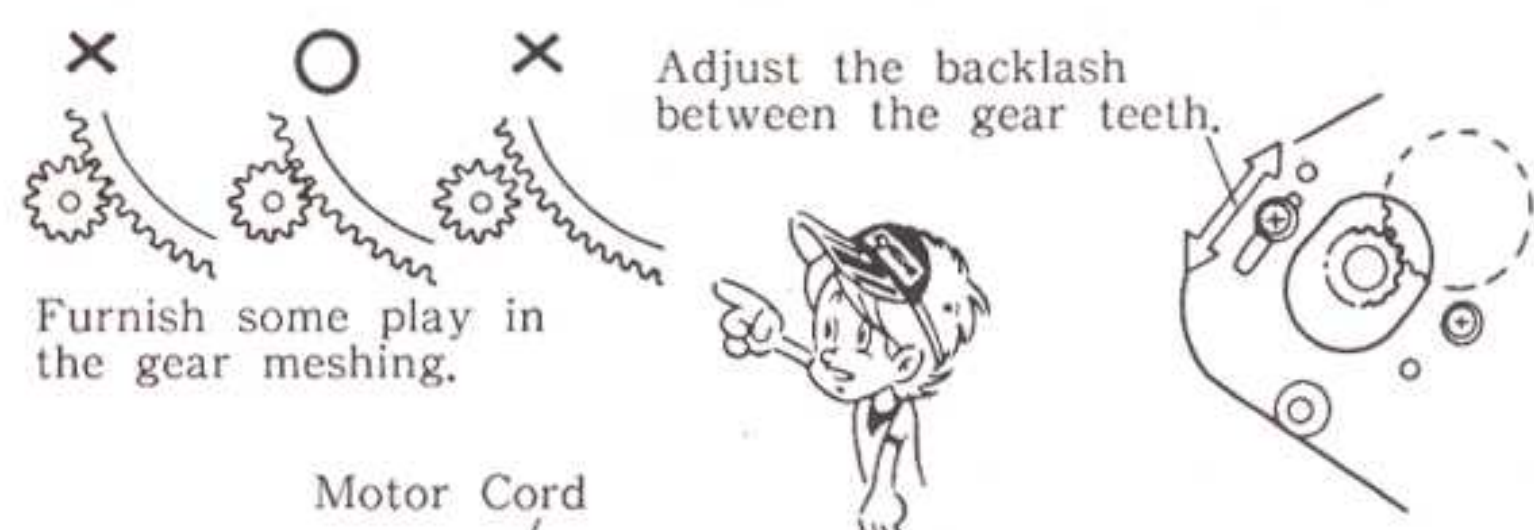

Cover the hole with the decal ①.

Le Mans Stock 05

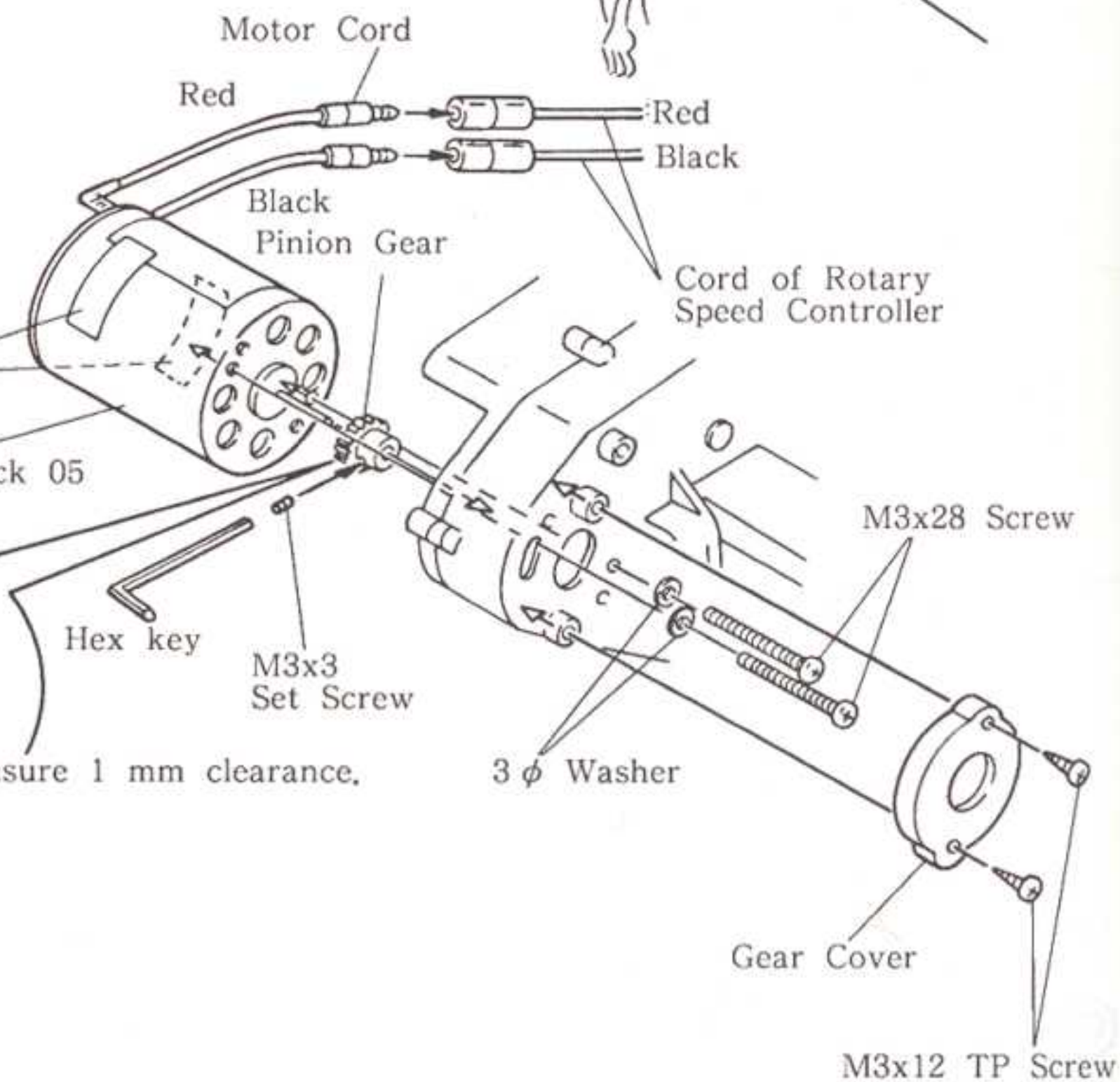

M3x28 Screws...2



3x12 TP Screws...2

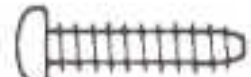

M3x3 Set Screw...1



3 φ Washers...2



Pinion Gear (13T)...1

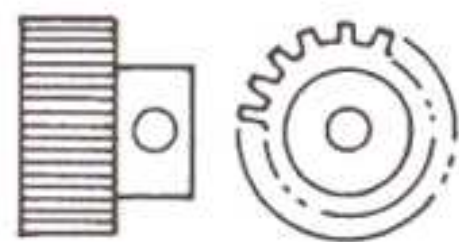

18 INSTALLATION OF COVER

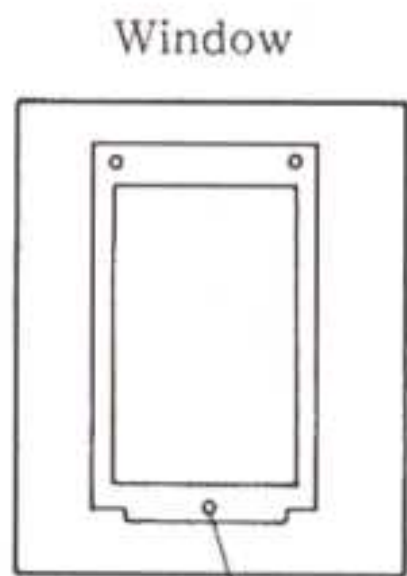

Cut out a perforation along with the cutout line and drill 3 mm dia. holes at three points.

Bundle the leads together and tie them up with a vinyl string.

The red, black, thin yellow and thin red cords of the rotary speedcontroller and the receiver's antenna.

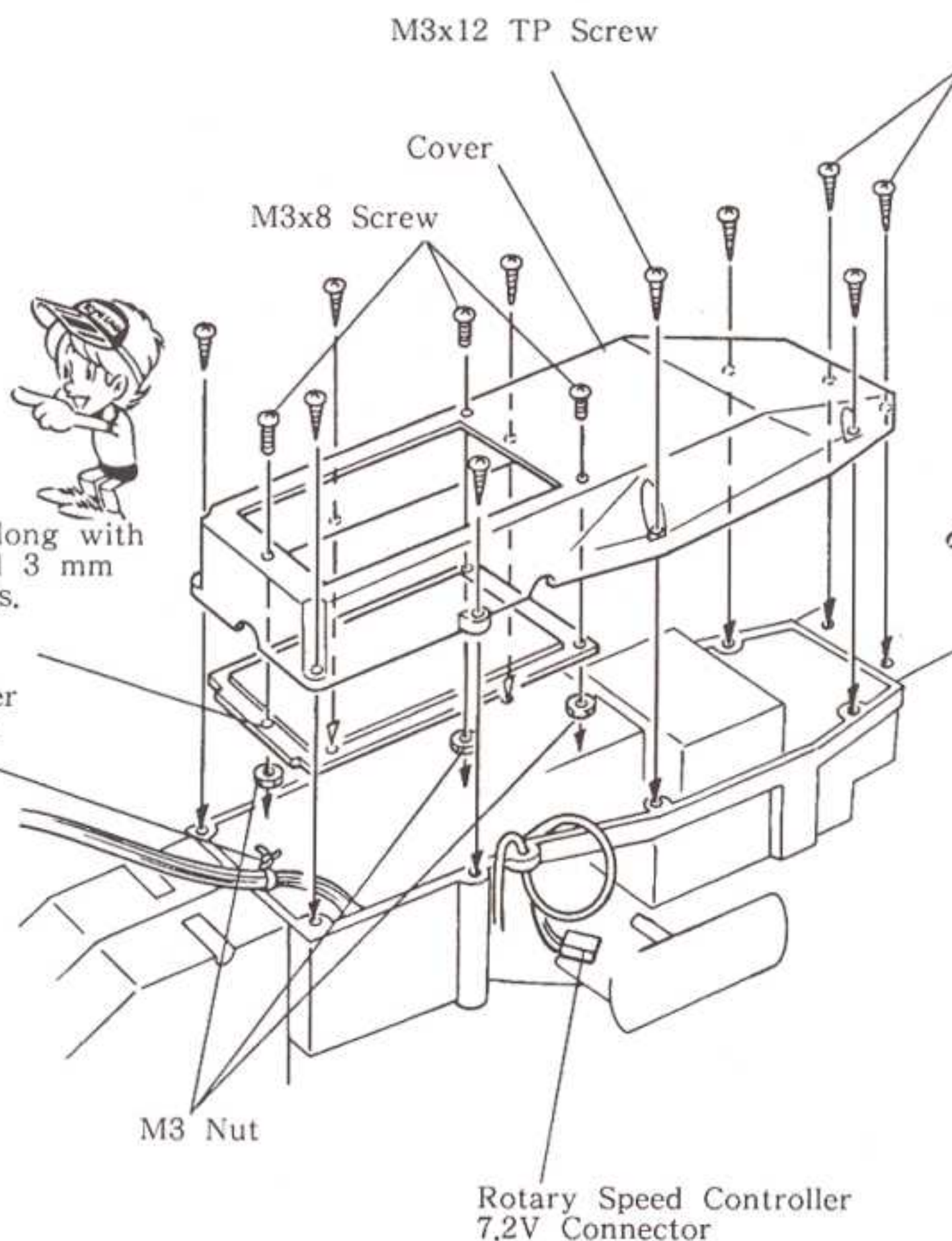

Remove the screw which was fixed in step 4, and fix the cover, then tighten the screw again.



*Route all the cords in the notch on the cover. Take care that they are not caught between the cover and the main frame.

M3x12 TP Screws...8

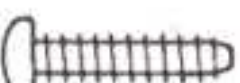

M3x8 Screws...3



M3 Nuts...3



19 INSTALLATION OF BODY MOUNT

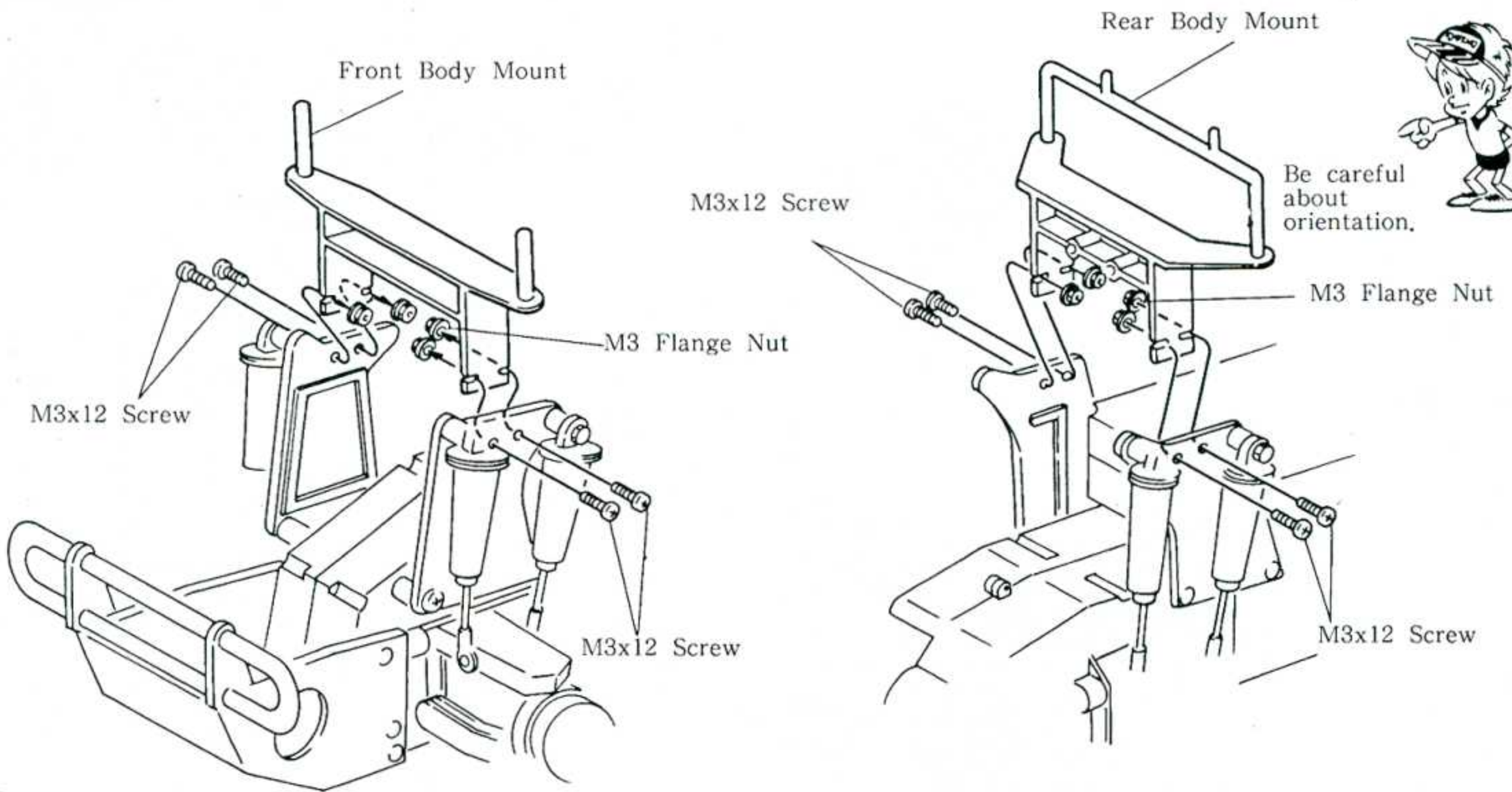

M3x12 Screws...8



M3 Flange Nuts...8



20 INSTALLATION OF RESISTOR

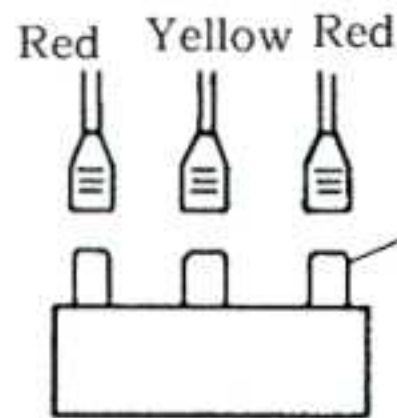

Put them gently so that the terminals will not bend.

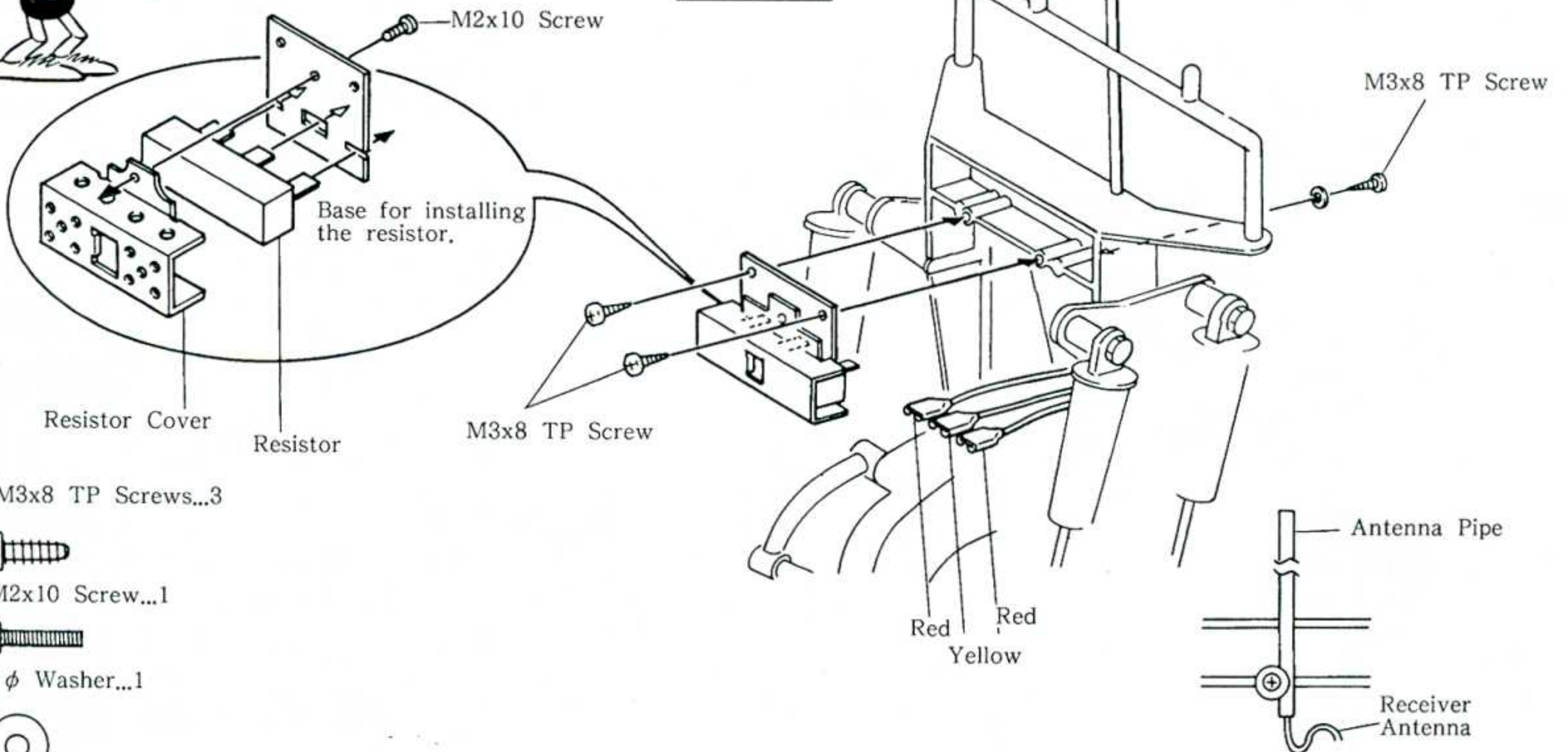

M3x8 TP Screws...3

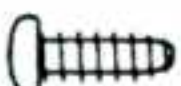

M2x10 Screw...1



3 φ Washer...1



21 INSTALLATION OF TIRE

M3x8 TP Screws...16

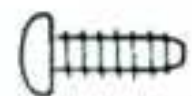

5 φ Washers...6

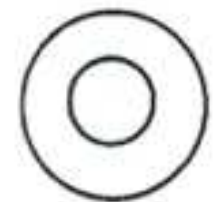

M4 Nylon Nuts...4



Wheel Shaft Pins...4



Wheel Hubs...4

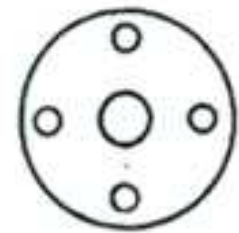

Front Wheel Shafts...2

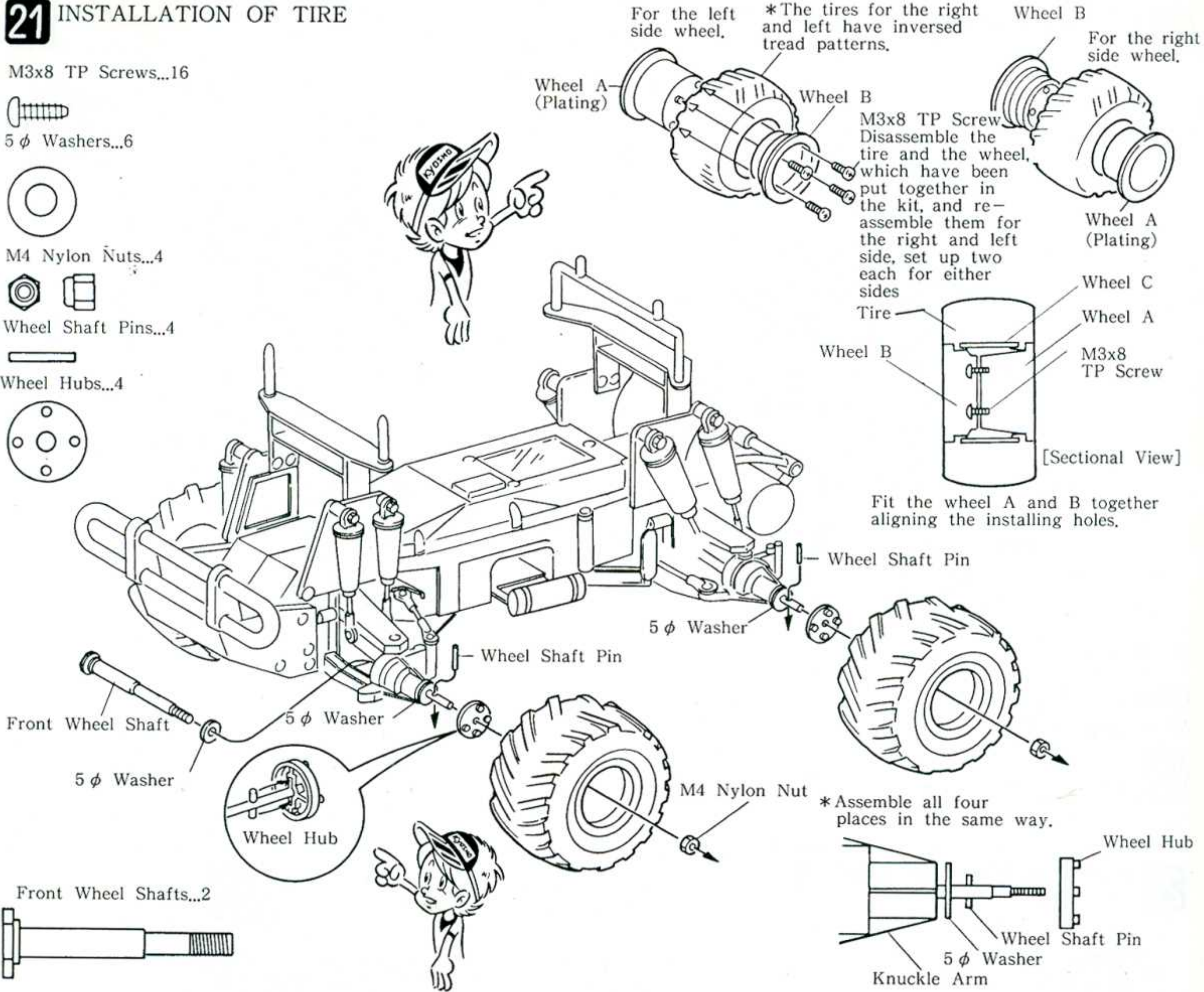
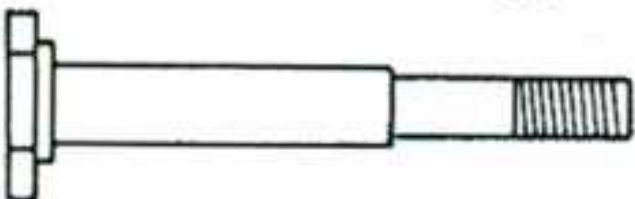

22 PAINTING OF BODY

Cut off the shaded area with scissors and a knife.

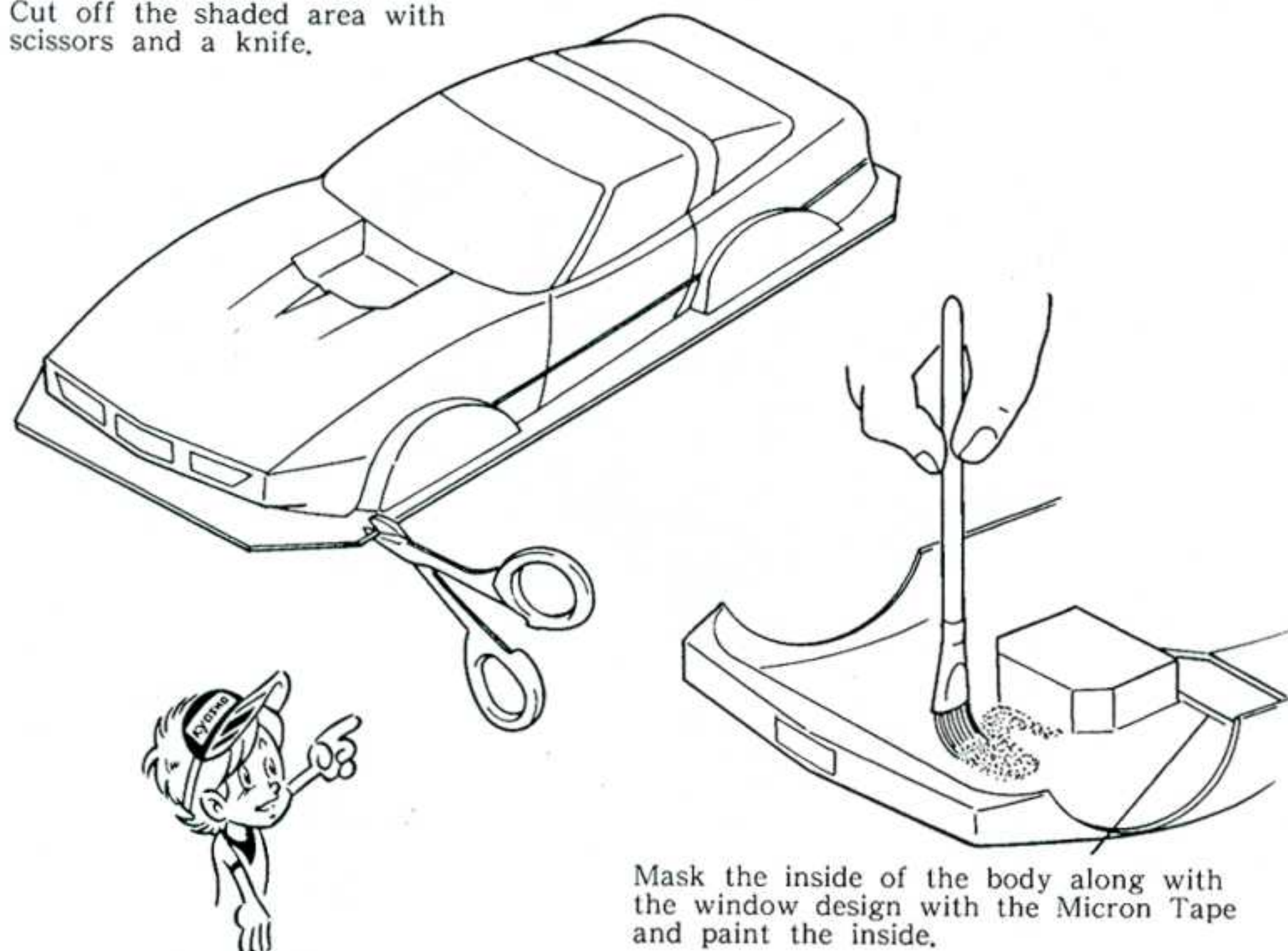

Round Cutter No.1828

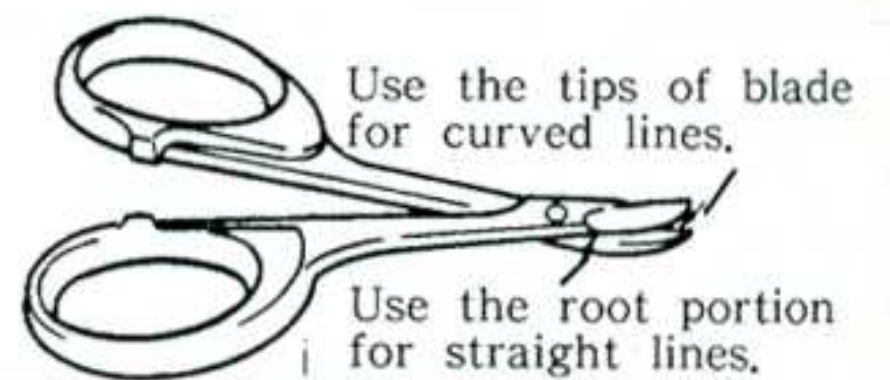

Micron Line Tape
No.1841...1 mm
No.1842...1.5mm
No.1843...2.5mm

Color
White, Red, Yellow
Green, Blue & Black

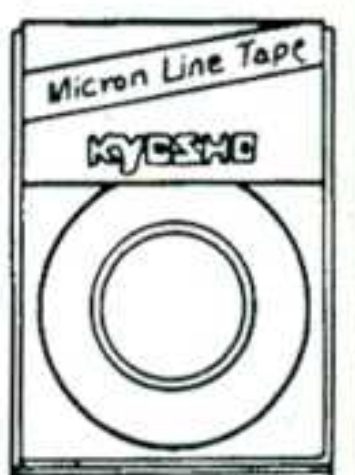

Polica Color No.2230

White, Red, Yellow, Green,
Blue, Sky Blue, Orange
Black, Violet, F.Pink
Yellow Green, F.Orange.



23 APPLY DECALS

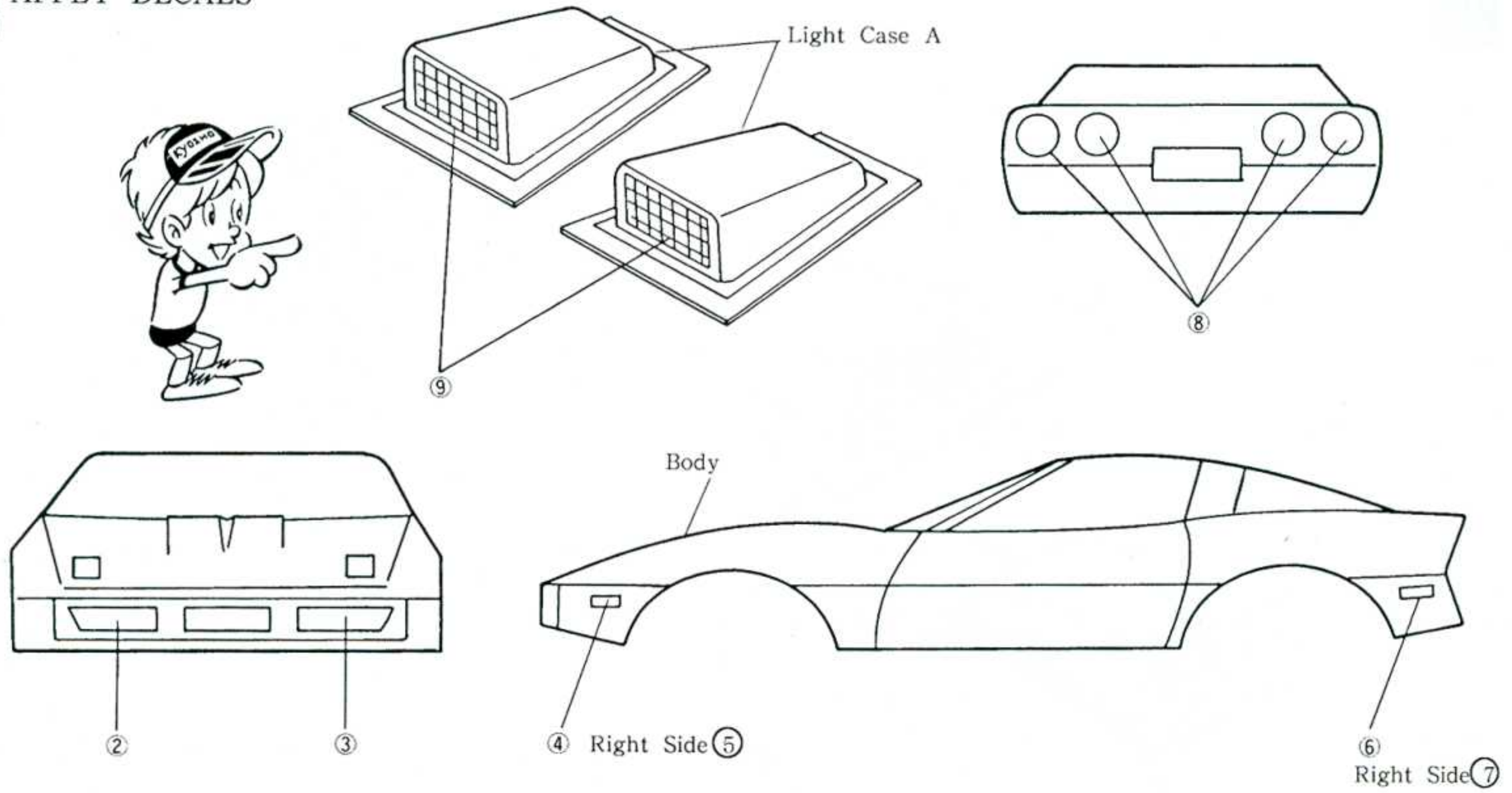

24 ASSEMBLY OF ENGINE

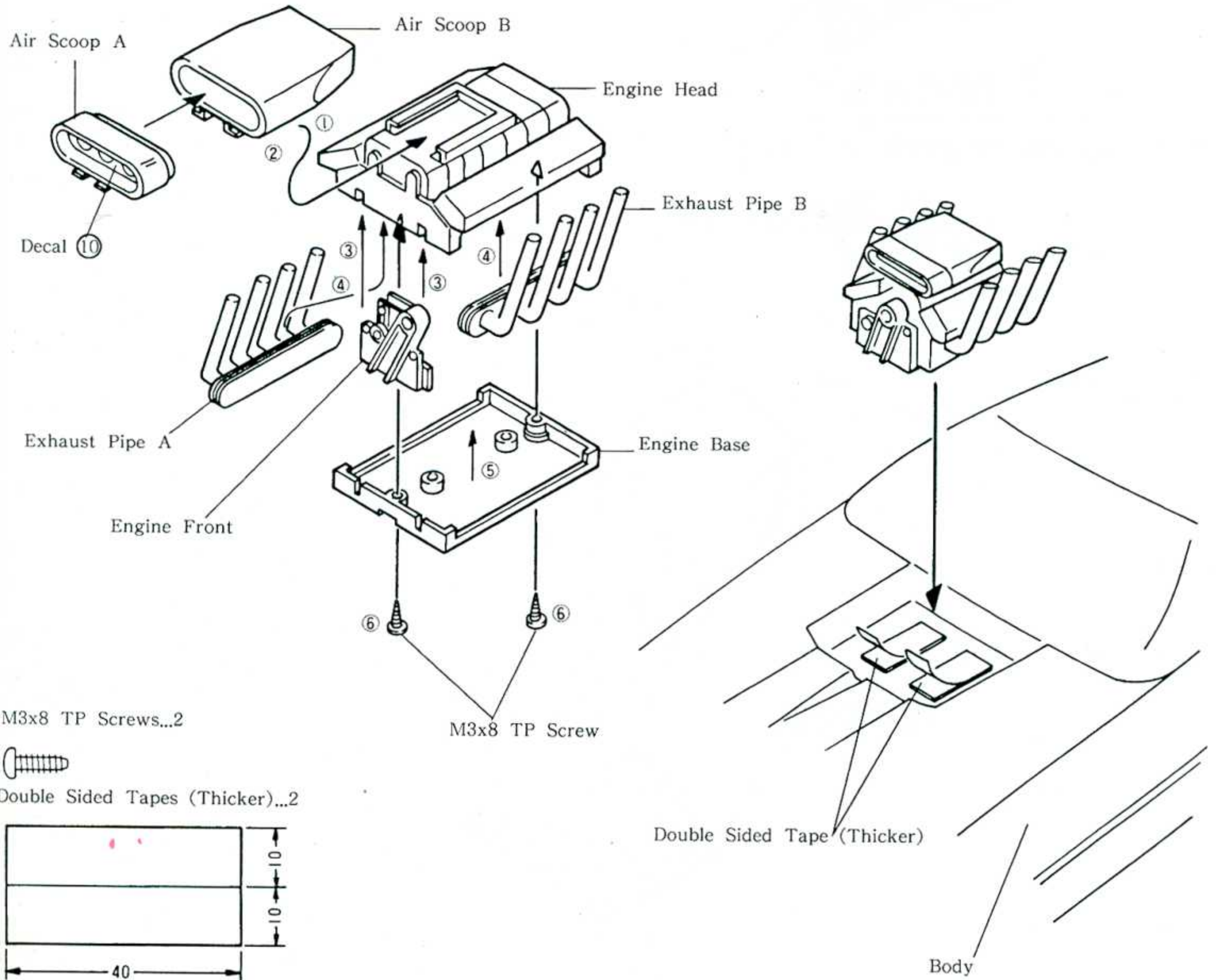

25 ASSEMBLY OF LIGHT (It is possible to make the light active, if you prefer.)

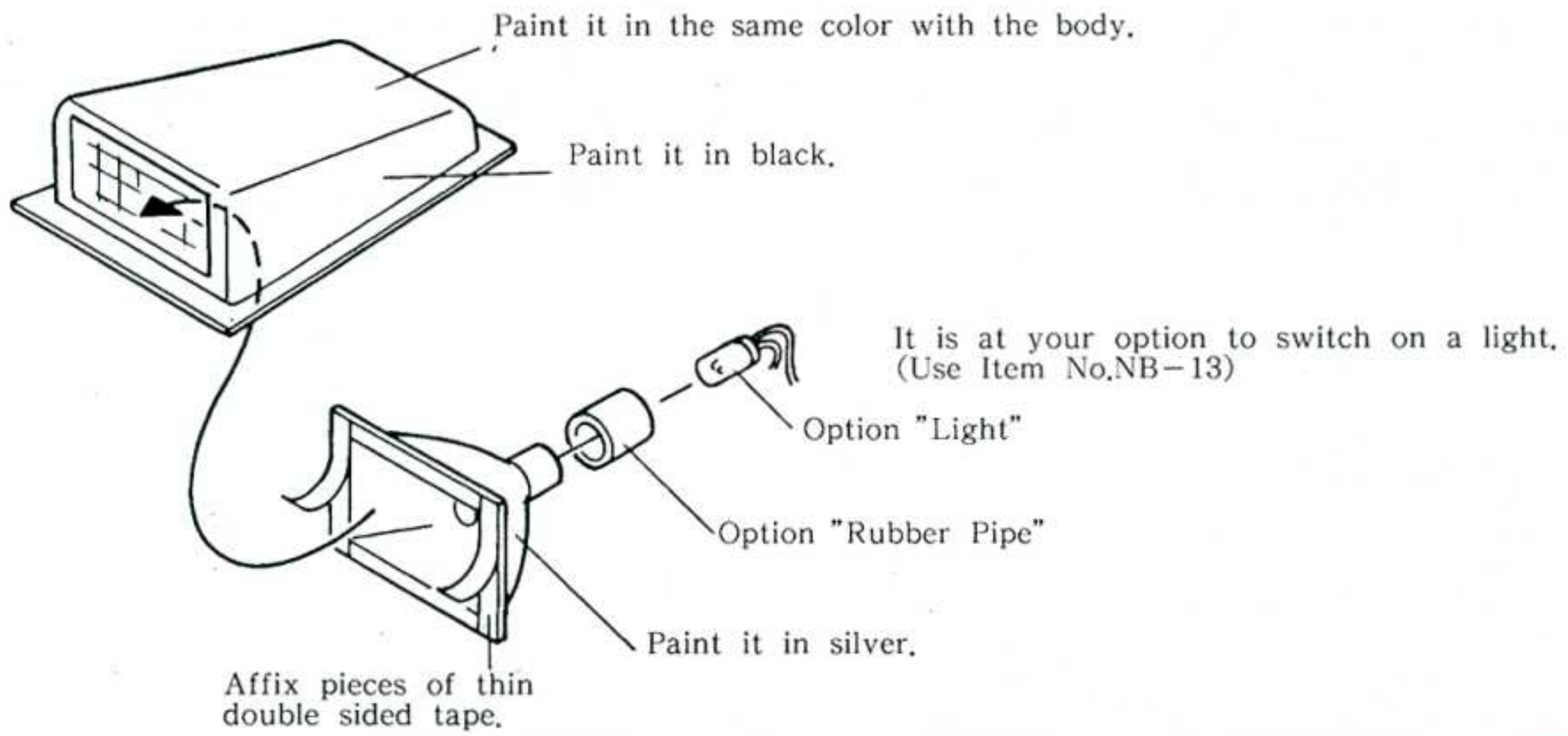
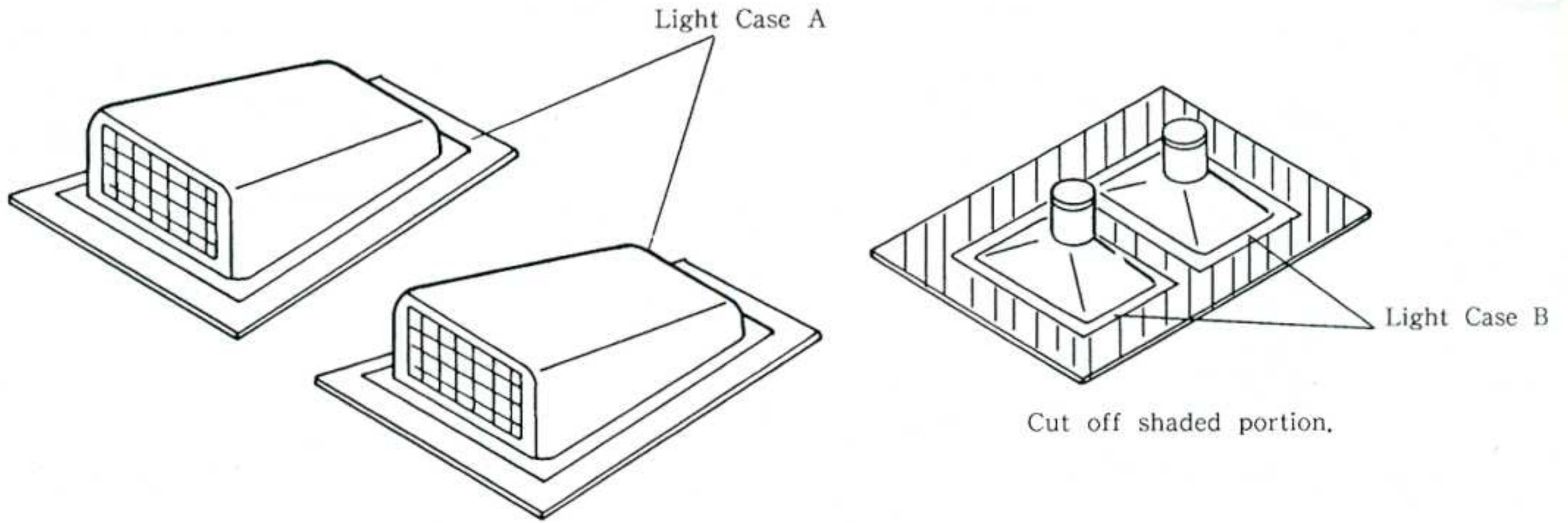

26 INSTALLATION OF LIGHT (It is possible to make the light active, if you prefer.)

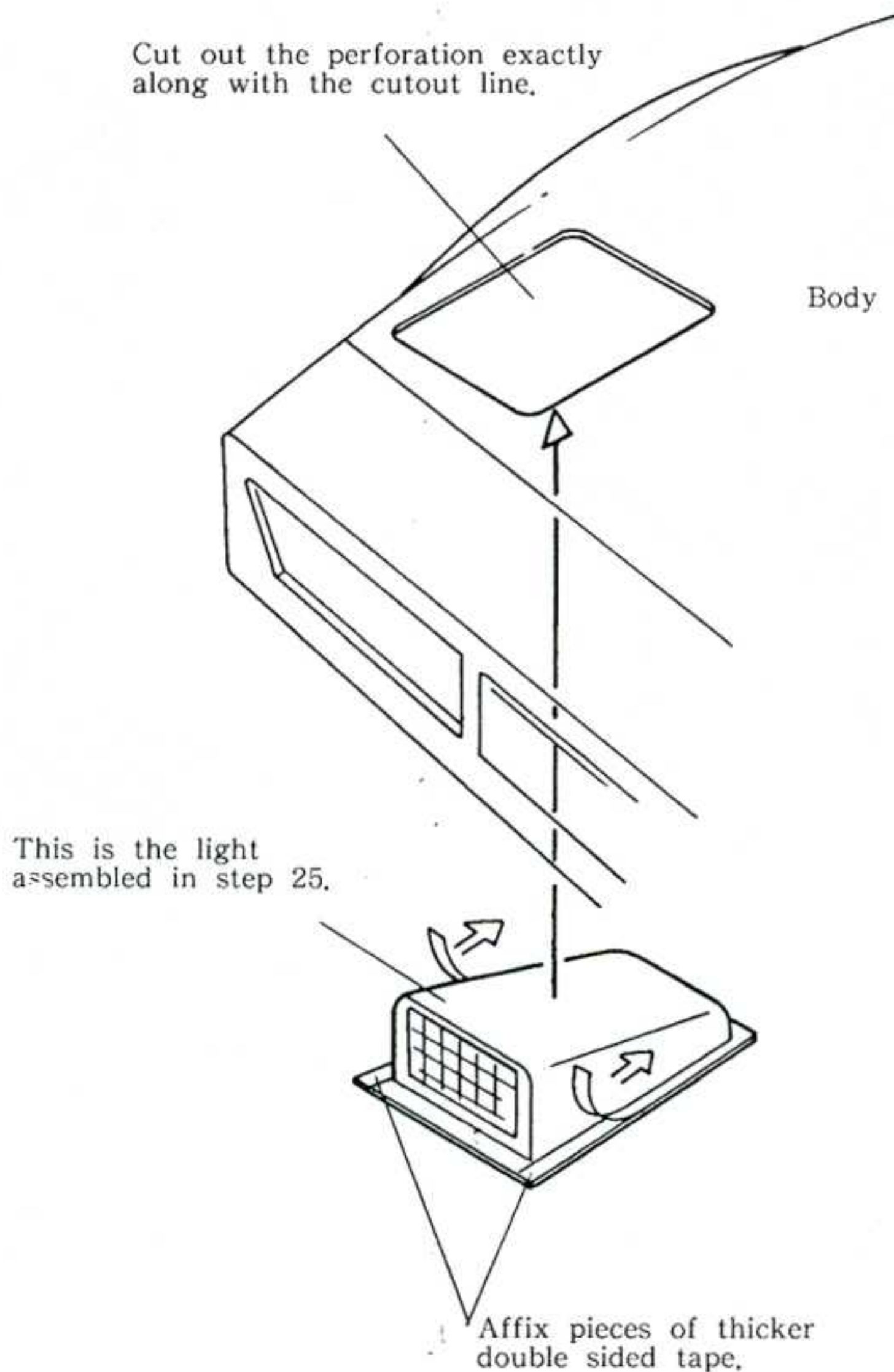

[Adjusting of Speed Controller]

Plug in the connector from the speed controller to the 7.2V Ni-Cd battery and operate your radio. While adjusting, the wheel of car may start to run, so keep your model upon a small box to make the wheels aloof from the ground.

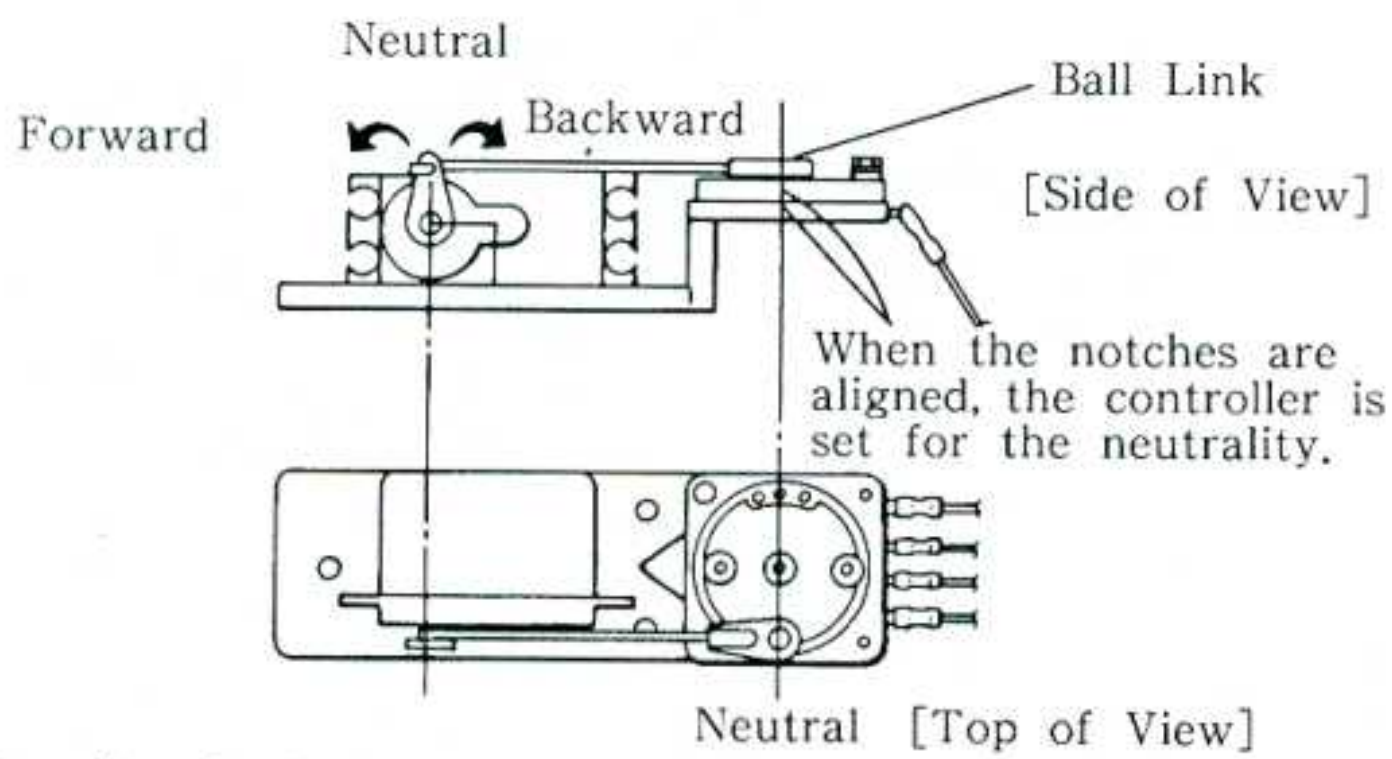

By turning the ball end, adjust the speed controller to the position shown in the drawing above (motor stopped position) with control stick and the trim lever in neutral.

① Adjustment for High Speed

When the control stick on your radio is pushed forward all the way, the controller should be activated and the motor should run at a high speed. By the motor sound, you can tell if the motor is running high, medium, or low speed.

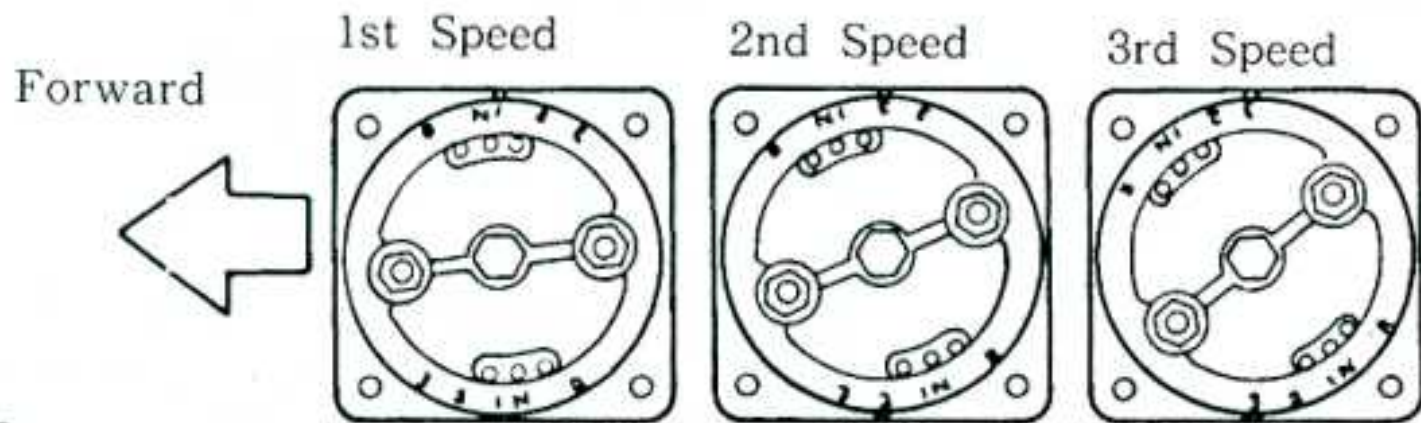

② Adjustment for Reverse

Pull the control stick and the control horn should operate as illustrated in the diagram below. The motor should run in reverse.

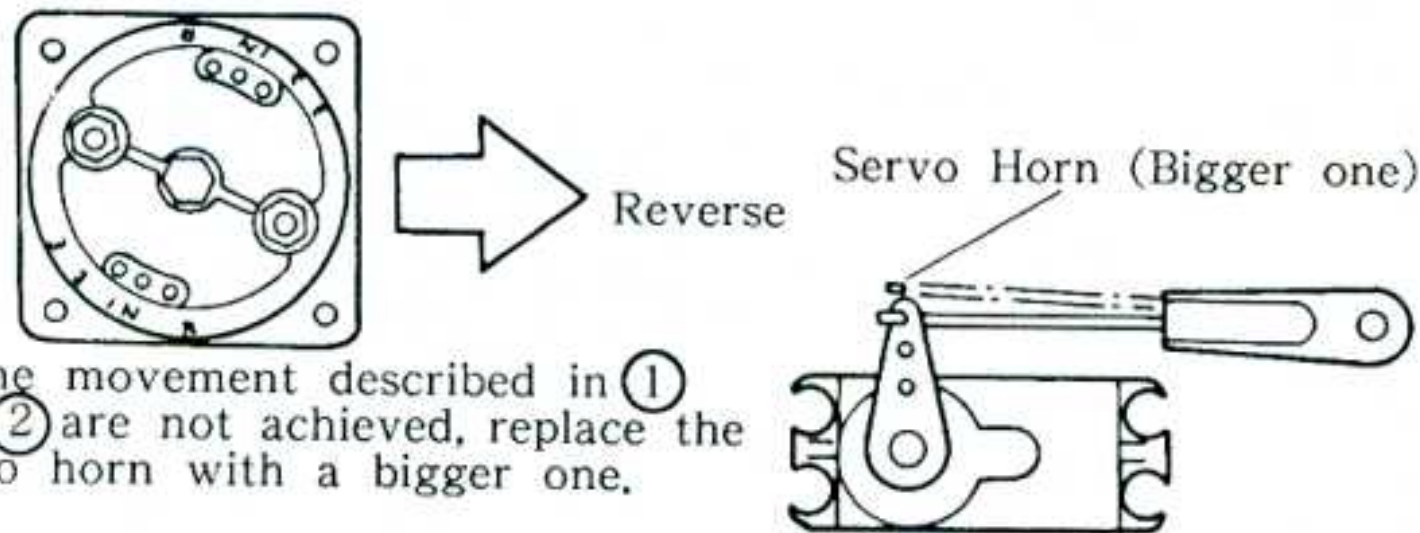

If the movement described in ① and ② are not achieved, replace the servo horn with a bigger one.

[Adjustment of Toe-In Angle]

This is an important adjustment to drive a car. Set up the front and rear wheels converge slightly toward the front. This toe-in adjustment helps the car go straight and enhance the steering trait.

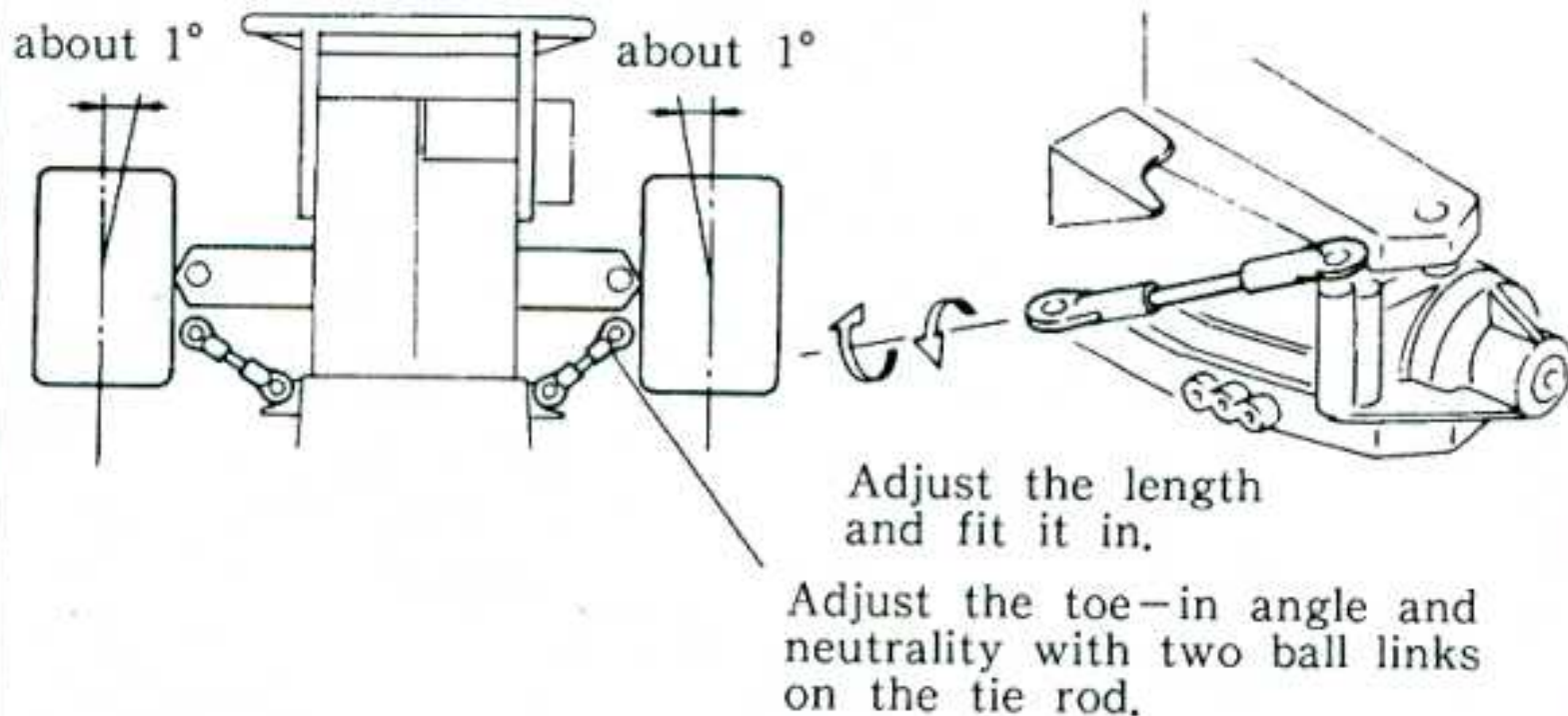

[Checking Speed Controller]

- (1) Check to see if the center nut or the lead fixing nuts are not loosen.
- (2) Check to see if the lead cords do not rub against the rotor or the center nut when the speed controller is in operation, as a result the points on the controller may be out of contact.
- (3) Or the lead may come in contact with the body and causing the same trouble as stated above in (2).
- (4) Check to see if the speed control rod does not rub against a lead fixing nut.

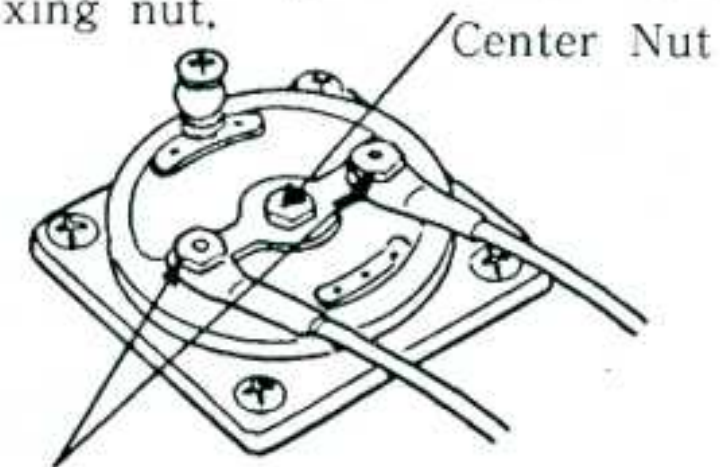

Lead Fixing Nut

[Up-Keep of Speed Controller]

- (1) Remove the center nut from time to time to check to see if anything in the controller. Clean it, if any.
- (2) Make it a rule to check all points from (1) to (4) stated above, before running the car.

*If you notice the motor running intermittently or unsmoothly, examine those four checking points. If you find nothing defective, the controller may be worn out. (In such a case, the surface of the controller plate becomes rough.)

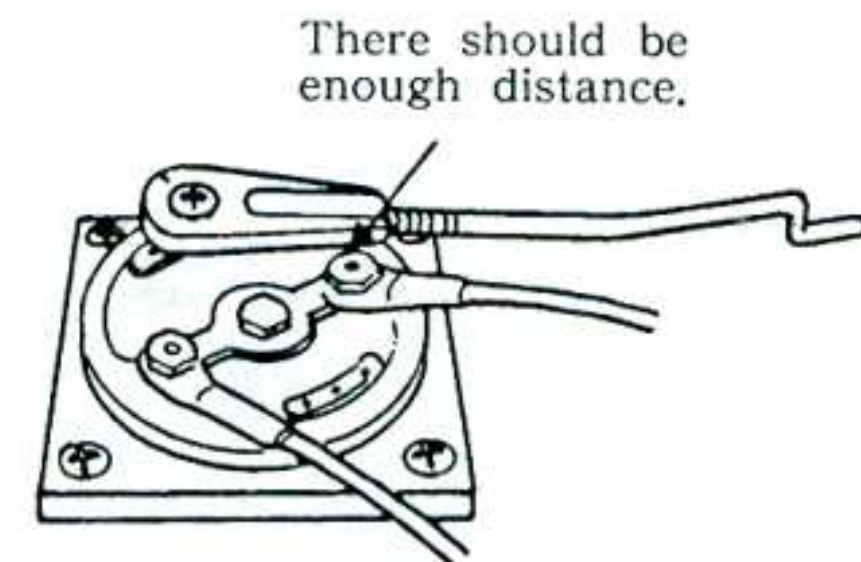
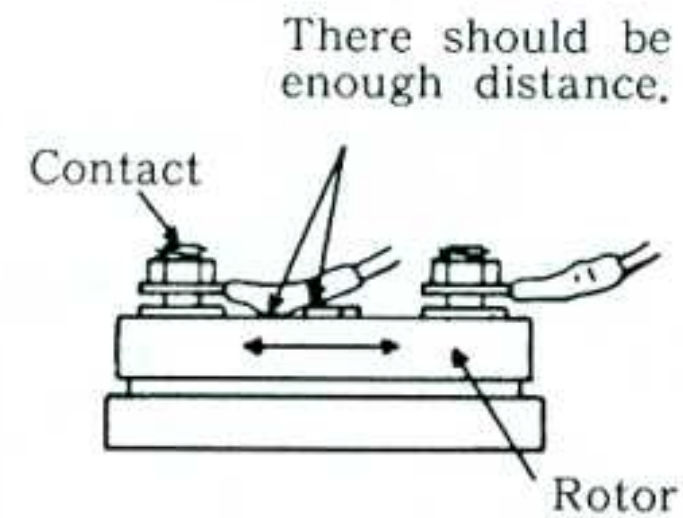

Cautions :

If you keep the car running at 1st and 2nd speeds, or backward advancing for more than 20 to 30 seconds, the resistor will generate heat. Try to drive your car at the 3rd speed as much as possible.

"HI-RIDER CORVETTE" EXPLODED VIEW

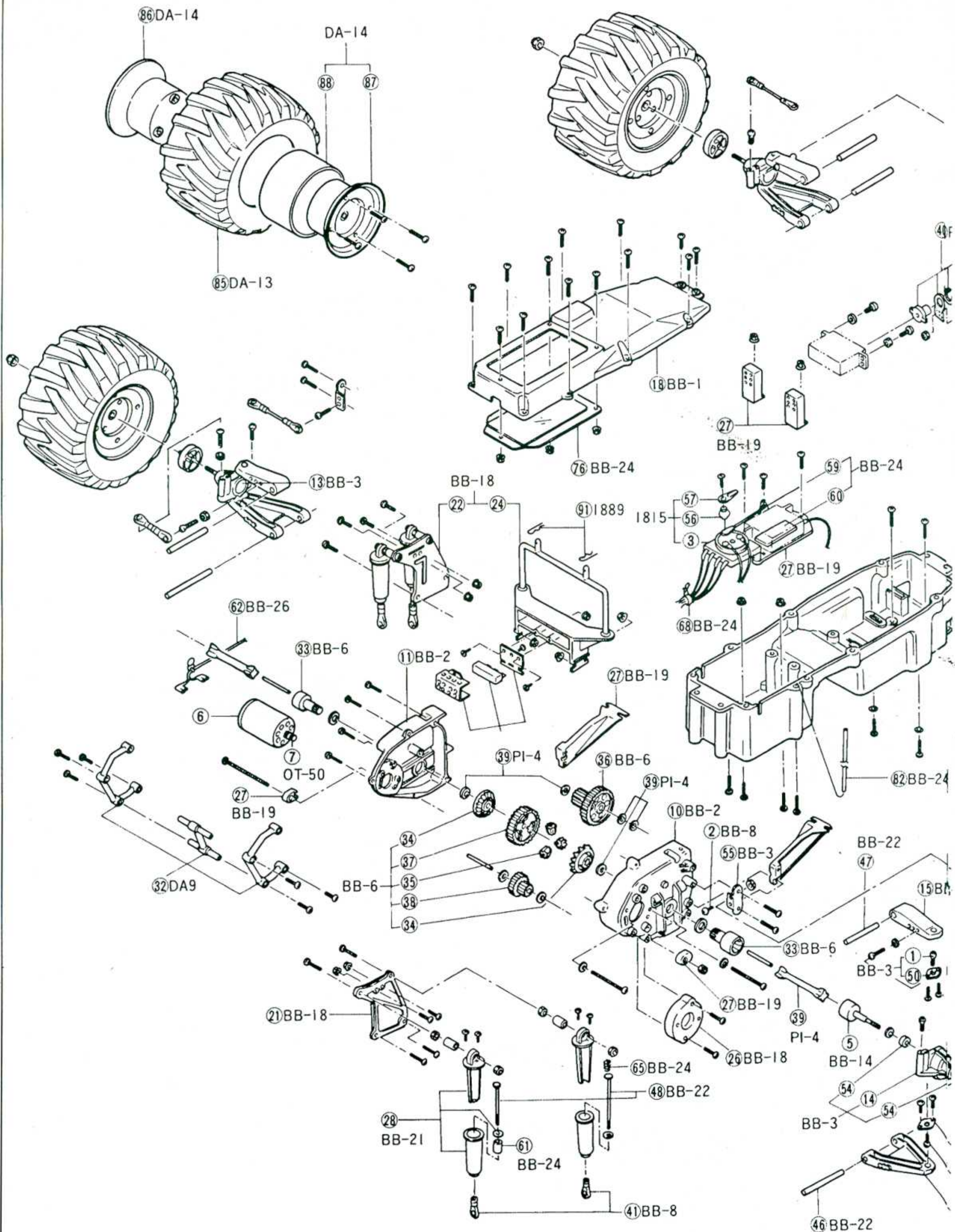

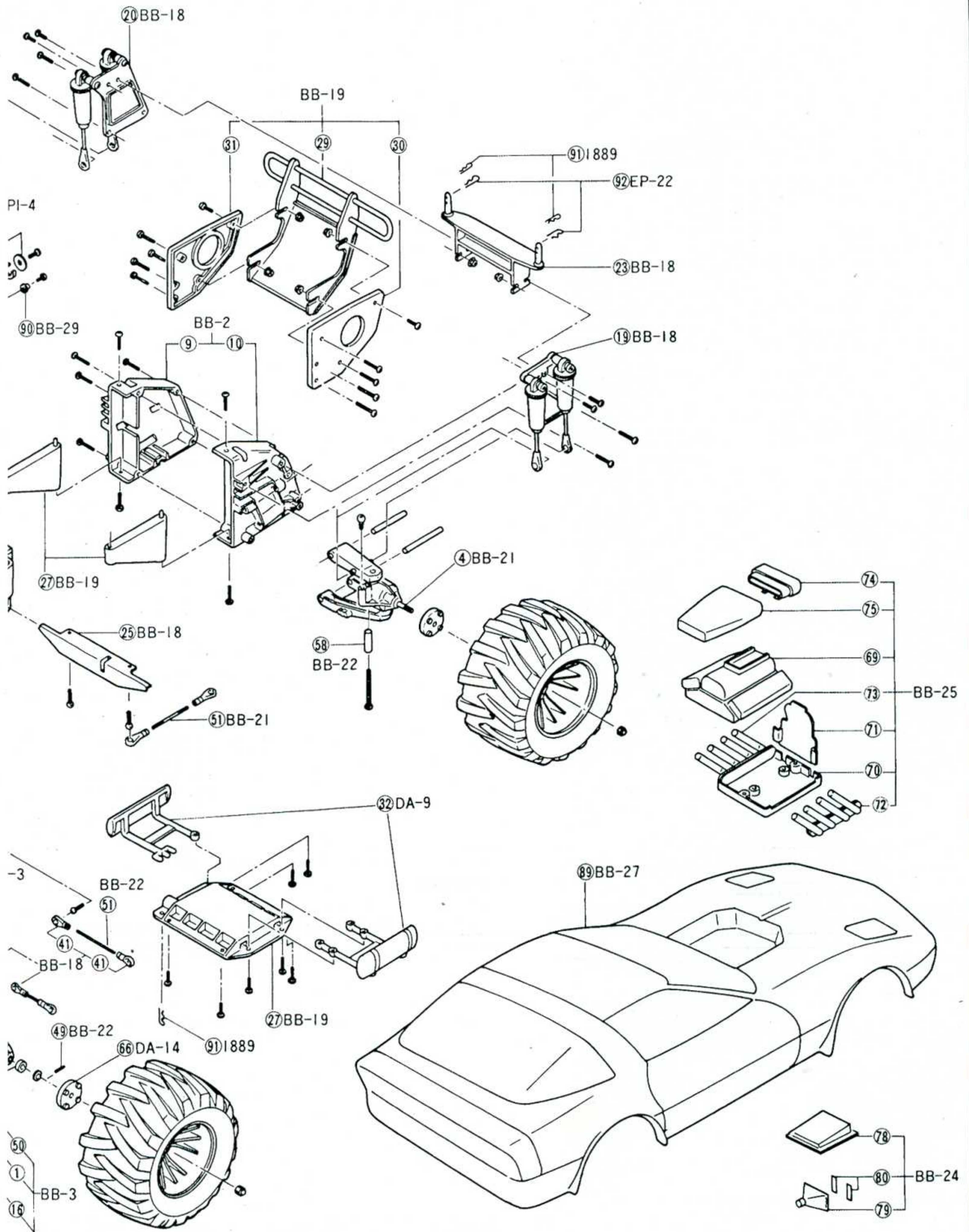

PARTS LIST

Key #	Parts Name	Q'ty	Key #	Parts Name	Q'ty	Key #	Parts Name	Q'ty	Key #	Parts Name	Q'ty
①	8 φ Pillow Ball	8	②④	Rear Body Mount	1	④⑦	Suspension Shaft (B)	2	⑦⑩	Engine Base	1
②	5.8 φ Pillow Ball	20	②⑤	Slider	1	④⑧	Shock Shaft	8	⑦⑪	Engine Front	1
③	Rotary Speed Controller	1	②⑥	Gear Cover	1	④⑨	Wheel Shaft Pin	4	⑦⑫	Exhaust Pipe (A)	1
④	Front Wheel Shaft	2	②⑦	(B) Block Parts	1	⑤⑩	Ball Seat	8	⑦⑬	Exhaust Pipe (B)	1
⑤	Rear Wheel Shaft	2	②⑧	(C) Block Parts	4	⑤⑪	M3 Rod (A)	4	⑦⑭	Air Scoop (A)	1
⑥	Le Mans Stock 05 Motor	1	②⑨	Front Guard	1	⑤⑫	M3 Rod (B)	2	⑦⑮	Air Scoop (B)	1
⑦	Pinion Gear (13T)	1	③⑩	Front Side Guard (R)	1	⑤⑬	4 φ Plain Bearing	2	⑦⑯	Window	1
⑧	Resistor	1	③⑪	Front Side Guard (L)	1	⑤⑭	5 φ Plastic Bearing	8	⑦⑰	Light Case (A) (L,R)	1
⑨	Bulk Head (A)	1	③⑫	(E) Block Parts	1	⑤⑮	Pillow Ball Base	2	⑦⑱	Light Case (B) (L,R)	1
⑩	Bulk Head (B)	1	③⑬	Diff. Joint	2	⑤⑯	4.5 φ Ball	1	⑧⑩	Double Sided Tape (thin)	1
⑪	Gearbox (A)	1	③⑭	Diff. Side Gear	2	⑤⑰	4.5 φ Ball Link	1	⑧⑪	Nylon Strap	1
⑫	Gearbox (B)	1	③⑮	Idle Gear	1	⑤⑱	Knuckle Collar	2	⑧⑫	Antenna Pipe	1
⑬	Knuckle Arm (A)	2	③⑯	Counter Gear	1	⑤⑲	Speed Control Rod	1	⑧⑬	Decal	1
⑭	Knuckle Arm (B)	2	③⑰	Diff. Carrier	1	⑥⑩	Double Sided Tape (thicker)	1	⑧⑭	Instruction	1
⑮	Upper Sus. Arm	4	③⑱	Diff. Bevel Gear	3	⑥⑪	Rubber Pipe	2	⑧⑮	Tire	4
⑯	Lower Sus. Arm	4	③⑲	(D) Block Parts	1	⑥⑫	Motor Cord	1	⑧⑯	Wheel (A)	4
⑰	Main Frame	1	④①	(Z) Block Parts	1	⑥⑬	Resistor Cover	1	⑧⑰	Wheel (B)	4
⑱	Cover	1	④②	5.8 φ Ball Link	20	⑥⑭	Resistor Holder Base	1	⑧⑱	Wheel (C)	4
⑲	Shock Stay (FR)	1	④③	Idle Gear Shaft Pin	1	⑥⑮	Shock Spring	4	⑧⑲	Body	1
⑳	Shock Stay (FL)	1	④④	Idle Gear Shaft	1	⑥⑯	Wheel Hub	4	⑨①	Eyelet	2
㉑	Shock Stay (RR)	1	④⑤	Counter Gear Shaft	1	⑥⑰	Grease	1	⑨②	Body Pin	5
㉒	Shock Stay (RL)	1	④⑥	Diff. Joint Shaft	1	⑥⑱	Vinyl Tape	1	⑨③	Hook Pin	4
㉓	Front Body Mount	1	④⑦	Suspension Shaft (A)	6	⑥⑲	Engine Head	1			

PURCHASABLE PARTS FOR YOUR KIT

You can purchase replacement and optional parts for your kit. All of the part identified by key number are usually not available singularly, but we offer these parts in convenient parts "pack" which can be purchased separately. To figure out which parts pack you need, find the key number for that part within the manual.

Then consult out parts pack guide below. When referring to the parts you need, always use the Parts Pack Number. For example, if you need a Idle Gear (Key #35) ask your dealer for Kyosho Parts Pack BB-6 (Gear Set).

No.	Parts Name	Key No. & Q'ty
BB-1	Frame Set	⑰×1, ⑱×1
BB-2	Bulk Head Gearbox Set	⑨×1, ⑩×1, ⑪×1, ⑫×1
BB-3	Sus. Arm Set	①×4, ⑬×1, ⑭×1, ⑮×2, ⑯×2, ⑳×4, ㉑×2
BB-6	Gear Set	⑩×2, ⑪×2, ⑫×2, ⑬×1, ⑭×1, ⑮×3
BB-8	5.8 φ Ball Link Set	②×12, ④×12
BB-14	Rear Wheel Shaft	⑤×2
BB-18	Shock Stay Set	⑲×1, ⑳×1, ㉑×1, ㉒×1, ㉓×1, ㉔×1, ㉕×1, ㉖×1
BB-19	Front Guard Set (For Corvette)	⑲×1, ㉑×1, ㉒×1
BB-20	B Block Parts	⑲×1
BB-21	C Block Parts	⑲×1
BB-22	Shaft Set (For Corvette)	④×2, ⑫×1, ⑬×1, ⑭×1, ⑮×1, ⑯×6, ⑰×2, ⑱×8, ⑲×4, ㉑×4, ㉒×2, ㉓×2, ㉔×2
BB-24	Small Parts Set (For Corvette)	⑳×1, ㉑×1, ㉒×2, ㉓×4, ㉔×1, ㉕×1, ㉖×1, ㉗ R.L. Each 1, ㉘ I.R.L. Each 1, ㉙×1, ㉚×1
BB-25	Engine Set	⑳×1, ㉑×1, ㉒×1, ㉓×1, ㉔×1, ㉕×1, ㉖×1
BB-26	Motor Cord	⑫×1
BB-27	Body (For Corvette)	⑲×1
BB-28	Decal (For Corvette)	⑬×1
BB-29	Screw Set (For Corvette)	⑩×2, Screw, Nut, Wrench etc.
DA-9	E Block Parts	⑲×1

No.	Parts Name	Key No. & Q'ty
DA-13	Spike Tire Set	⑳×2
DA-14	Wheel Set	⑳, ㉑, ㉒, ㉓×2
PI-4	DZ Block Parts	⑲×1, ⑳×1
OT-50	Pinion Gear	⑦×1
EP-22	Hook Pin	⑫×5
1815	Rotary Speed Controller	③×1, ⑥×1, ⑦×1
1819	15W Resistor Set	⑧×1, ⑬×1, ⑭×1
1889	Body Pin	⑨×1
Optional Parts		
1903	Ball Bearing (4 φ x8 φ)	2pcs.(Instead of D-3 & 4 φ Plain Bearing)
1901	Ball Bearing (5 φ x8 φ)	2pcs.(Instead of 5 φ Plastic Bearing)
PI-15	Ball Bearing (8 φ x12 φ)	2pcs.(Instead of D-4)
W-5002	Pressure Shock (L)	Constant Volume Type Shock x 2 set
W-5004	Adjustable Oil Shock	2 set
1951	Shock Oil (S.M.L)	For Oil Shock
OT38	Silicon Grease	For Gear & Plain Bearing
1883	Frontier Hobby Oil	For Gear & Plain Bearing
SC40	Motor Cover	Protect from dirt
1863	Sponser Sticker	
1856	Fog Light Set	Light (4), Case, Battery Case
NB-13	Light Set	w/Light (2), Battery Case

The following option parts are required to make "Corvette Hi-Rider" perfect with ball bearings.

- 1903 Ball Bearing.....2 set
- 1901 Ball Bearing.....4 set
- PI-15 Ball Bearing.....1 set

This products is not to be sold in the United States. If you have purchased this product in the United States, please contact Tom Miller at Kyosho U.S.A. phone number (217) 398-3630'