

RADIO CONTROLLED ELECTRIC POWERED OFF-ROAD RECREATIONAL VEHICLE

CAR CRUSHER

THE BOSS

- STYLISH FORD-F250 TRUCK BODY ON RUGGED BIG BRUTE CHASSIS.
 - HUGE GROUND-STRIDING 146 MM TIRES.
 - HIGH-TORQUE LE MANS STOCK 05 MOTOR AND ROTARY SPEED CONTROLLER INCLUDED IN KIT.
 - DOUBLE WISHBONE FOUR WHEEL INDEPENDENT SUSPENSION ARM AND FRICTION-TYPE SHOCK ABSORBERS ON EACH WHEEL.
 - STRONG, LIGHT MONOCOCQUE CHASSIS.
- 7.2V-1200MAH NI-CD BATTERY AND 2 CHANNEL RADIO ARE NOT INCLUDED.

1:10 SCALE



KYOSHO
THE FINEST RADIO CONTROL MODELS

KIT NO. 3108

BEFORE ASSEMBLY

*Be well aware of the different types of screws.

1. The difference between the TP screw (short form of self-tapping screw) and the ordinary screw is...

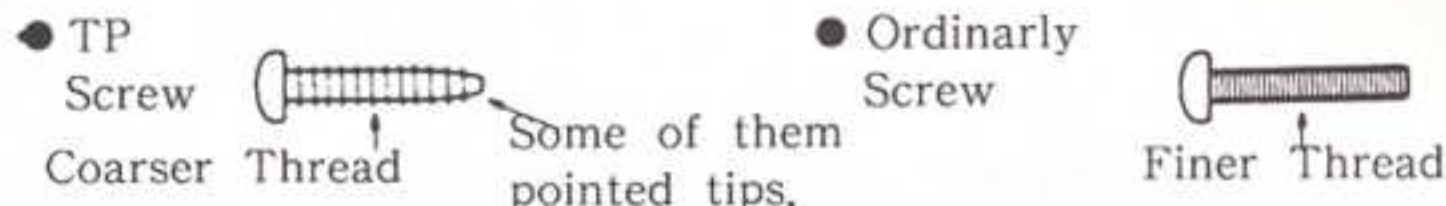

2. The kinds of screws which will be used in this instruction.

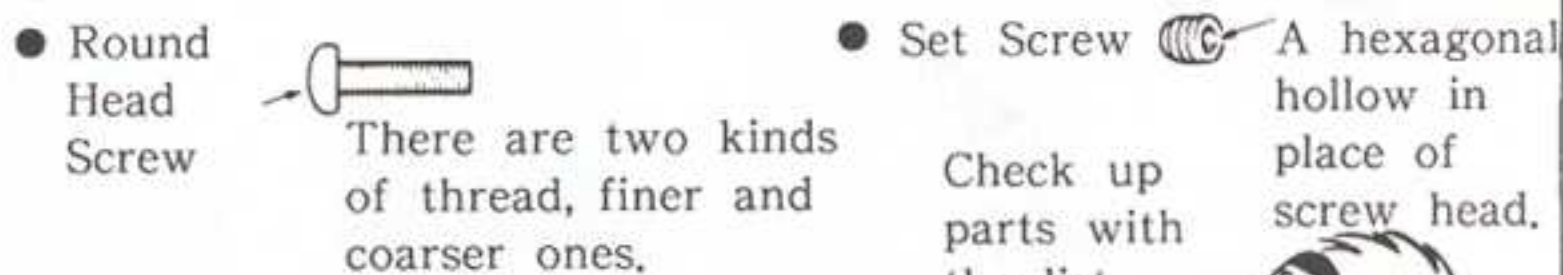

*Pick up the correct parts and screw. Compare the shape and size of small parts, such as screws, nuts, and washers with the attached sheet of "List of Small Parts"

*Be sure about the location and direction of parts to install.

Double-check the location and orientation of parts with the illustration before installation. When necessary, assemble the parts themselves tentatively before proceeding to the next step.

*Do not tighten the TP screw too strong... Do not use excessive force when tightening the TP screws, or you may strip the thread in the plastic. It is recommended to stop tightening it when the thread part on the screw goes into the plastic part and you feel some resistance from the tightening.

Over tighten may strip the thread in the plastic.

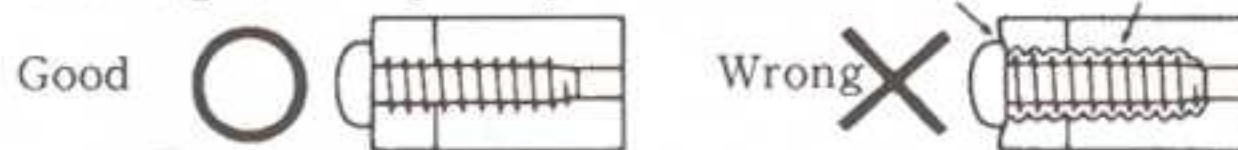

*Read the instruction carefully.

Oh, I see



Instruction

You can assemble the kit more easily if you have grasped the general idea of steps and structure beforehand by reading it through to the end.
*Check the parts in the kit. Check to see if all the parts are correctly bagged as they are listed in the List of Bagged Parts. Your thorough understanding of the assembly prior to starting will enable you to build the kit without any difficulty.

What the back is this

OK



List of bagged parts

Check the components in the kit prior to your starting the assembly.

Any claims for replacements or refunds for the model in the process of assembly will not be accepted without shortage or inferiority of the parts.

*Learn on the marks described in the instruction.

Steps where your particular attention is required.



GREASE ... Place where grease should be applied. It will reduce friction to assure smooth movements.

THINGS NEED BESIDES THE KIT

[2 Channel Radio System]

This model is designed for BEC system radio only. Use a radio which has a mark shown at left.



Two types of radio control set are on the market, the stick type and the steering wheel type. Choose which ever you like.

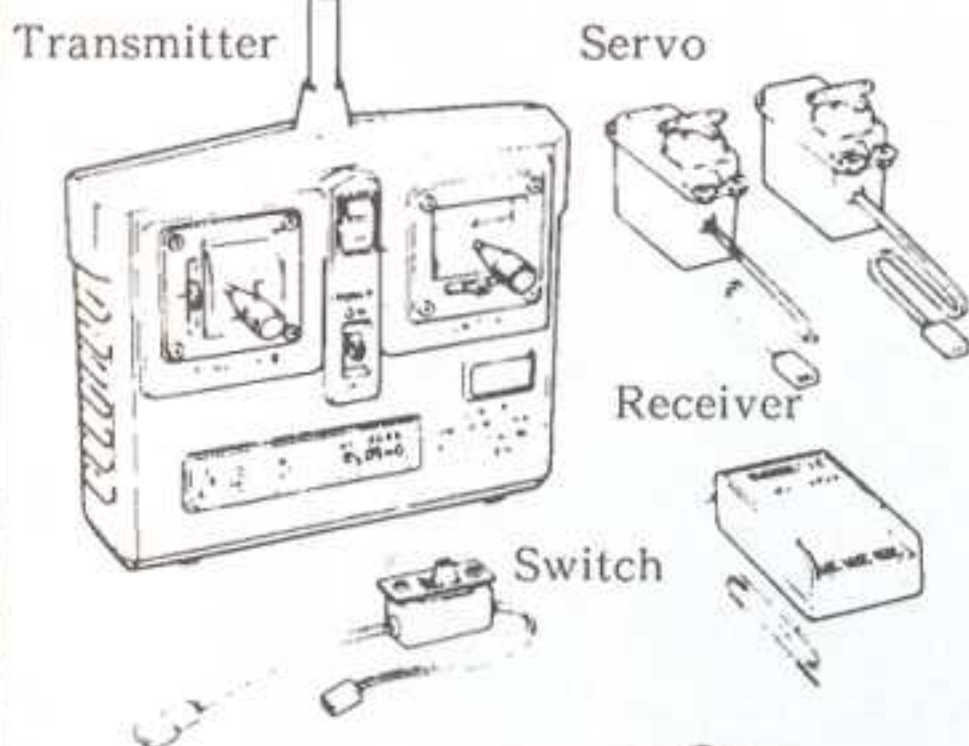

AA Size Battery
For Transmitter...8pcs.
For Receiver...4pcs.

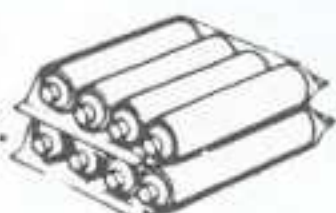

[NiCd Battery]

Any of these batteries is suitable to Big Boss

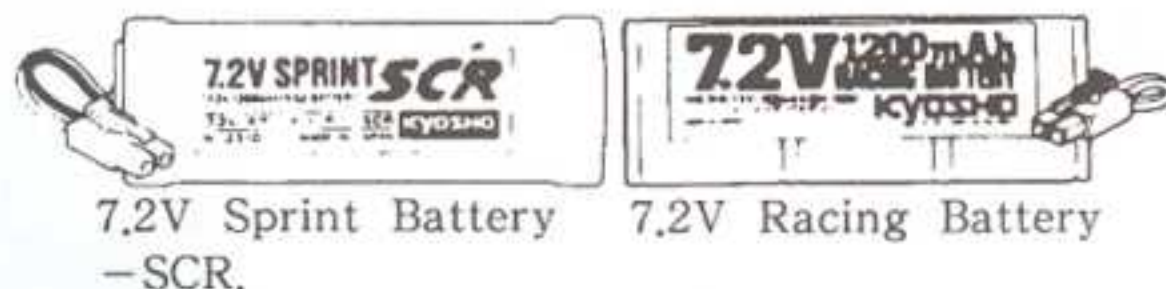

7.2V Power Battery

"Big Boss" is designed to use a rechargeable 7.2V Sprint Battery SCR, 7.2V Racing Battery and 7.2V Power Battery.

[Charger for NiCd Battery]

The Kyosho's NiCd battery is high performance. If it is charged correctly, it will operate for a considerable period.

Use one of the chargers listed below which suits your need

Model	Name	Time	Rate%	Features
2326	7.2V Power Charger DC12V	15 min.	about 70%	For beginner Timer built in.
1849	Multi Charger II DC12V	20 min.	100%	Timer, Ammeter built in
2246	FET Auto Charger DC12V	20 min.	100%	Automatic cut-off at peak of charge

[Required Tools] Hex key, Grease and CW cement are included with the kit.

Philips Screw Driver (L,M,S)

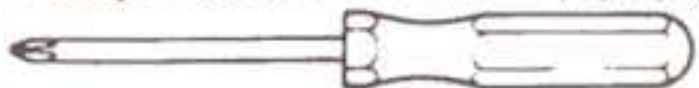

Box Driver (for M3 & M4 Nut)



Sharp Hobby Knife



Needle Nose Plier

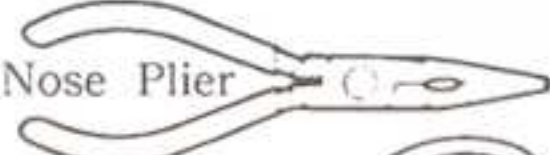

Round Cutter



Sander



Awl

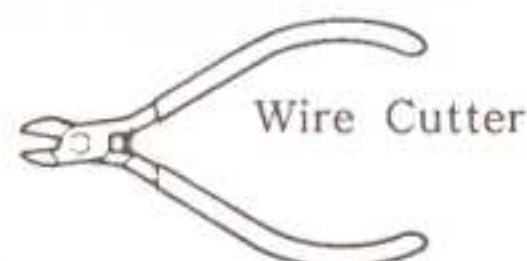

Instant Glue



Polycap Paint



Brush



Micron Line Tape

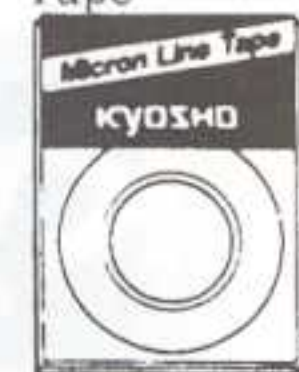

LIST OF BAGGED PARTS "THE BOSS"

Bag	Key #	Parts Name	Q'ty	Step
BIG-1	1	Bulk Head A	1	4
	2	Bulk Head B	1	4
	3	Gearbox A	1	1
	4	Gearbox B	1	2
BIG-2	5	Knuckle Arm A	2	3
	6	Knuckle Arm B	2	3
	7	Upper Suspension Arm	4	3
BIG-3	8	Lower Suspension Arm	4	3
	9	Main Frame	1	4
BIG-4	10	Cover	1	18
	11	Block Parts B	1	3, 7, 8, 9, 10
BBA-5	12	Block Parts C	2	18
HRD-6	13	Block Parts E	1	12, 16
BBA-7	14	Front Guard	1	11
	15	Front Side Guard R	1	11
	16	Front Side Guard L	1	11
HRD-8	17	Engine Head	1	27
	18	Engine Base	1	27
	19	Engine Front	1	27
	20	Exhaust Pipe A	1	27
	21	Exhaust Pipe B	1	27
	22	Air Scoop A	1	27
	23	Air Scoop B	1	27
BBA-9	24	Shock Stay FR	1	14
	25	Shock Stay FL	1	14
	26	Shock Stay RR	1	14
	27	Shock Stay RL	1	14
	28	Front Body Mount	1	19
	29	Rear Body Mount	1	19
	30	Slider	1	9
BIG-10	31	Gear Cover	1	17
	32	Differential Joint	2	1, 2
	33	Differential Side Gear	2	1, 2
	34	Idle Gear	1	1
	35	Counter Gear	1	2
	36	Differential Carrier	1	2
	37	Differential Bevel Gear	3	2
BBA-11	38	D Block Parts	1	1, 2, 10
	39	Z Block Parts	1	3
	40	5.8φ Ball Link	16	10, 13
	41	Idle Gear Shaft	1	1
	42	Idle Gear Shaft Pin	1	1
	43	Counter Gear Shaft	1	2
	44	Differential Joint Shaft	1	1
	45	Suspension Shaft A	6	5
	46	Suspension Shaft B	2	5
	47	Shock Shaft	4	13
	48	Wheel Shaft Pin	4	21
	49	Ball Seat	8	3
	50	M3 Rod A	4	10
	51	M3 Rod B	2	10
	52	4φ Plain Bearing	2	1
	53	5φ Plastic Bearing	8	3
	BBA-12	54	Pillow Ball	2
55		4.5φ Ball	1	7
56		4.5φ Ball Link	1	7
57		Knuckle Coller	2	10
58		Speed Control Rod	1	7
59		Double Sided Tape	1	7, 9, 21
60		Rubber Pipe	1	13, 15
61		Motor Cord	1	17
62		Resistor Cover	1	20 Assembly
63		Resistor Holder Base	1	20 Assembly
64	Resistor	1	20 Assembly	

Bag	Key #	Parts Name	Q'ty	Step
BBA-12	65	Shock Spring	4	13
	66	Wheel Hub	4	21
	67	Grease	1	
	68	Vinyl Tie	1	13
	69	Nylon Strap	1	17
BBA-13	70	8φ Pillow Ball	8	3
	71	5.8φ Pillow Ball	16	4, 5, 10
	72	Front Wheel Shaft	2	21
	73	Rear Wheel Shaft	2	10
	74	Pinion Gear (13T)	1	17
	75	Window	1	13
	76	Rotary Speed Controller	1	7
BBA-14	78	Le Mans Stock 05 Motor	1	17
BBA-15	79	Front Grill	1	23
	80	Rear Bumper	1	23
	81	Headlight Lens	2	23
	82	Fog Light Lens	4	23
BBA-16	83	Roll Bar	1	24
	84	Roll Bar Base (A)	2	24
	85	Roll Bar Base (B)	2	24
BBA-17	86	Fog Light	4	23
	87	Mirror (A)	1	24
	88	Mirror (B)	1	24
	89	Tail Light	2	24
	90	Front Grill Stopper	2	23
Others	91	Antenna Pipe	1	20
	92	Decal	1	
	93	Instruction	1	
	94	Tire	4	21
	95	Wheel A	4	21
	96	Wheel B	4	21
	97	Wheel C	4	21
	98	Body	1	22
	99	Eyelet	2	13, 9
	100	Body Pin	5	16
	101	Hook Pin	4	
	102	Cross Wrench	1	
BBA-18		TP Screw M3×16	18	
		TP Screw M3×12	53	
		TP Screw M3×8	37	
		TP Screw M2×6	26	
		Screw M3×60	1	
		Screw M3×28	4	
		Screw M3×25	4	
		Screw M3×12	16	
		Screw M3×8	5	
		Screw M2×15	1	
		Screw M2×10	2	
		Set Screw M3×3	1	
		Washer 8φ	2	
		Washer 5φ	8	
		Washer 3φ	16	
	Nylon Nut M4	4		
	Nylon Nut M3	5		
	Flange Nut M3	18		
	Nut M3	13		
	Nut M2	1		
	Stopper 3φ	8		
	Hex Key	1		
	TP Screw M3×6	2		

DRAWING OF PLASTIC PART PLACEMENT "THE BOSS"

Ⓑ Block Part 1 pc.

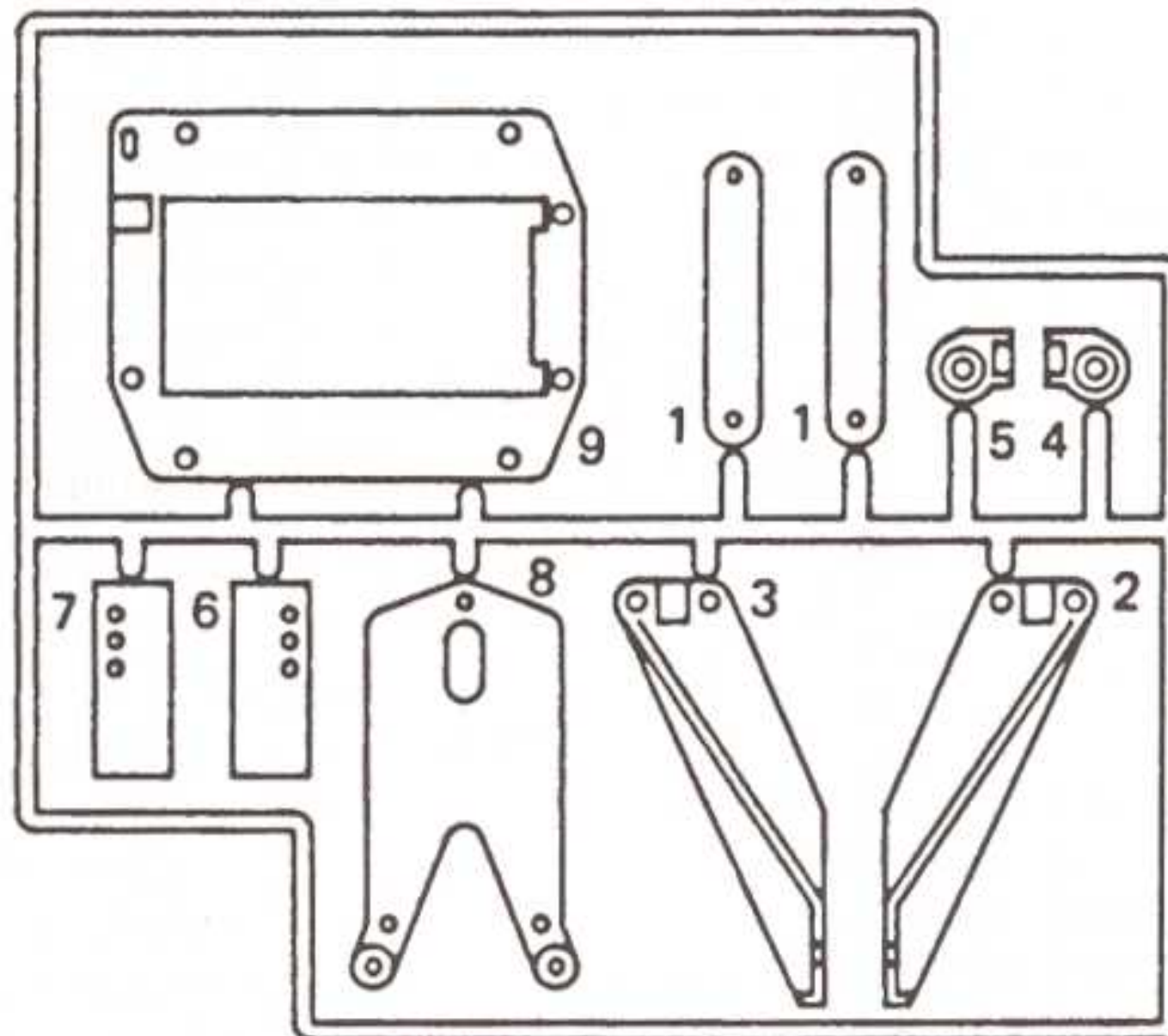

Ⓒ Block Parts 2 pcs.

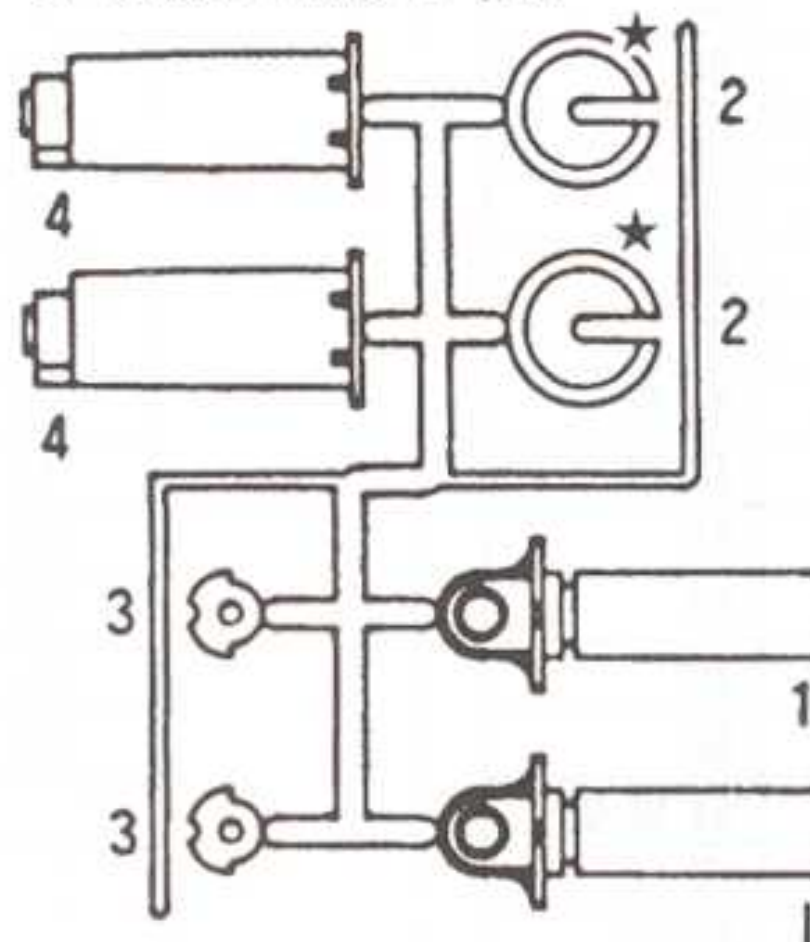

Ⓓ Block Part 1 pc.

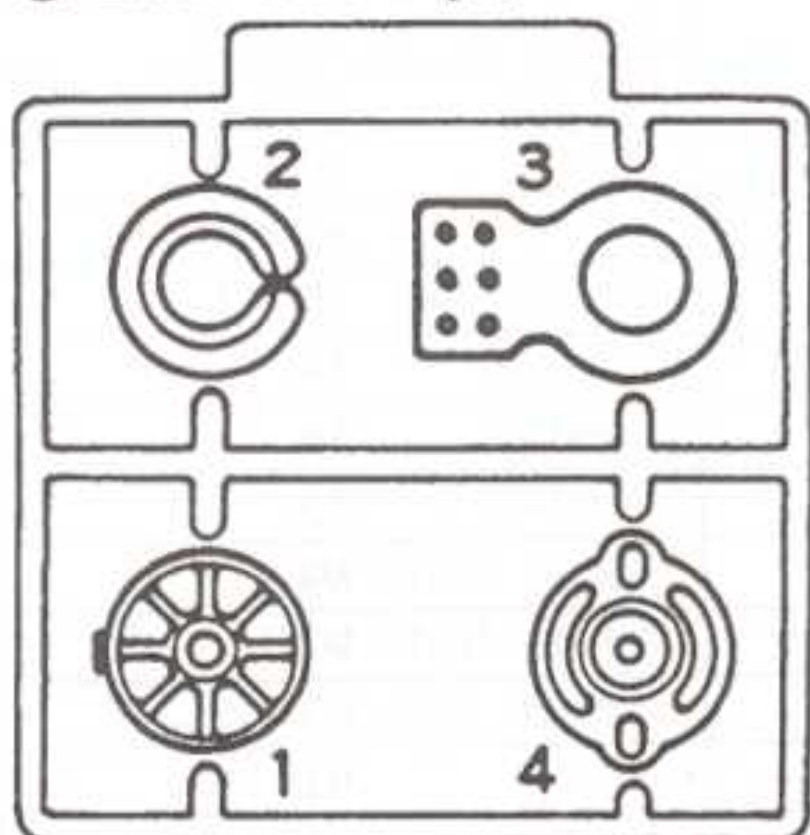

Ⓔ Block Part 1 pc.

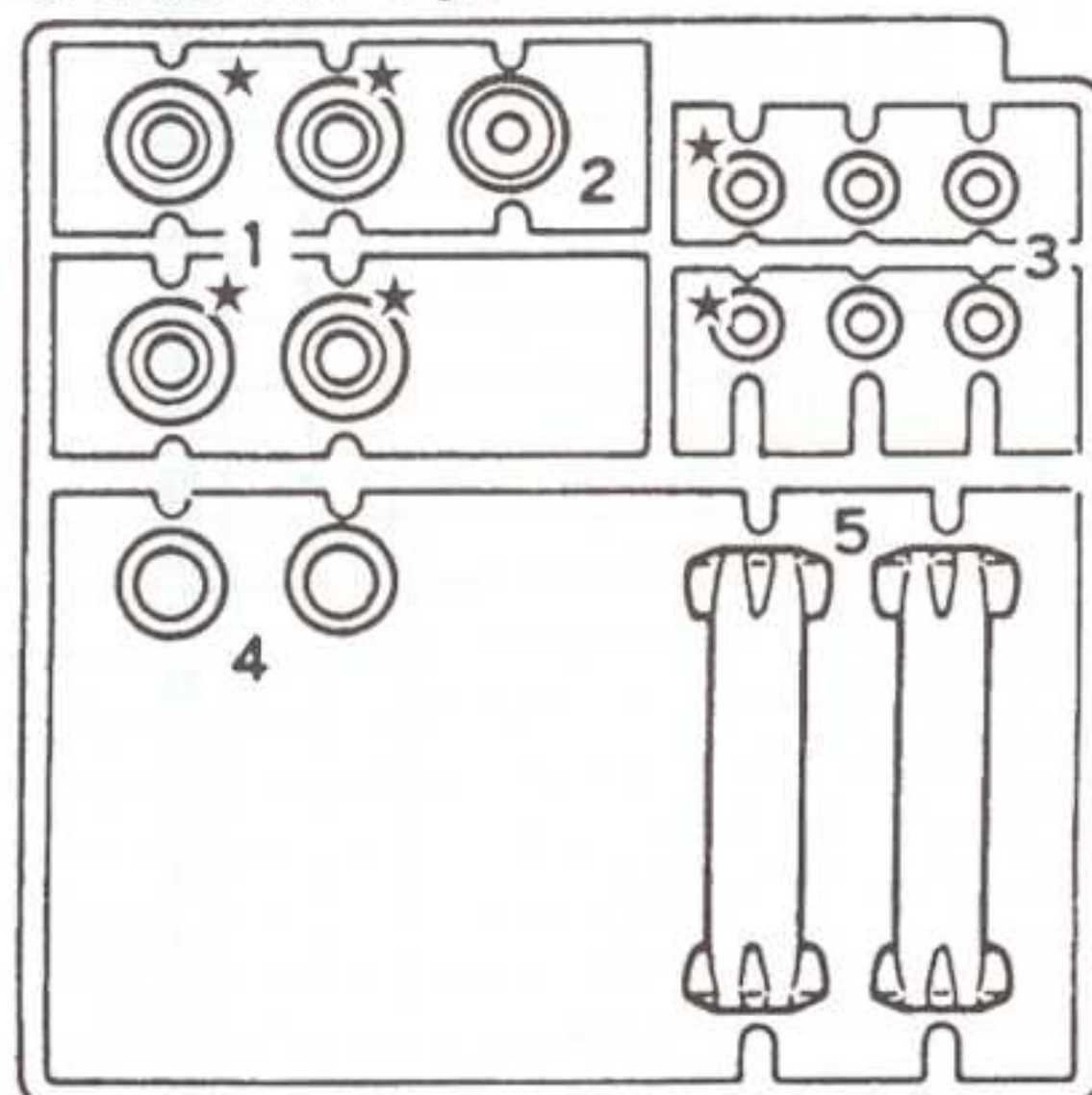

★ These parts are not used.

1 ASSEMBLY OF GEARBOX

8φ Washer 1

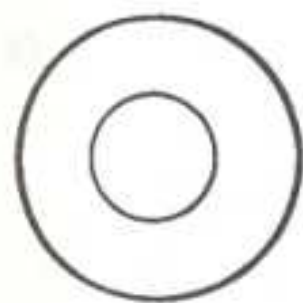

Idle Gear Shaft 1



Differential Joint Shaft 1



Idle Gear Shaft Pin 1



4φ Plain Bearings 2

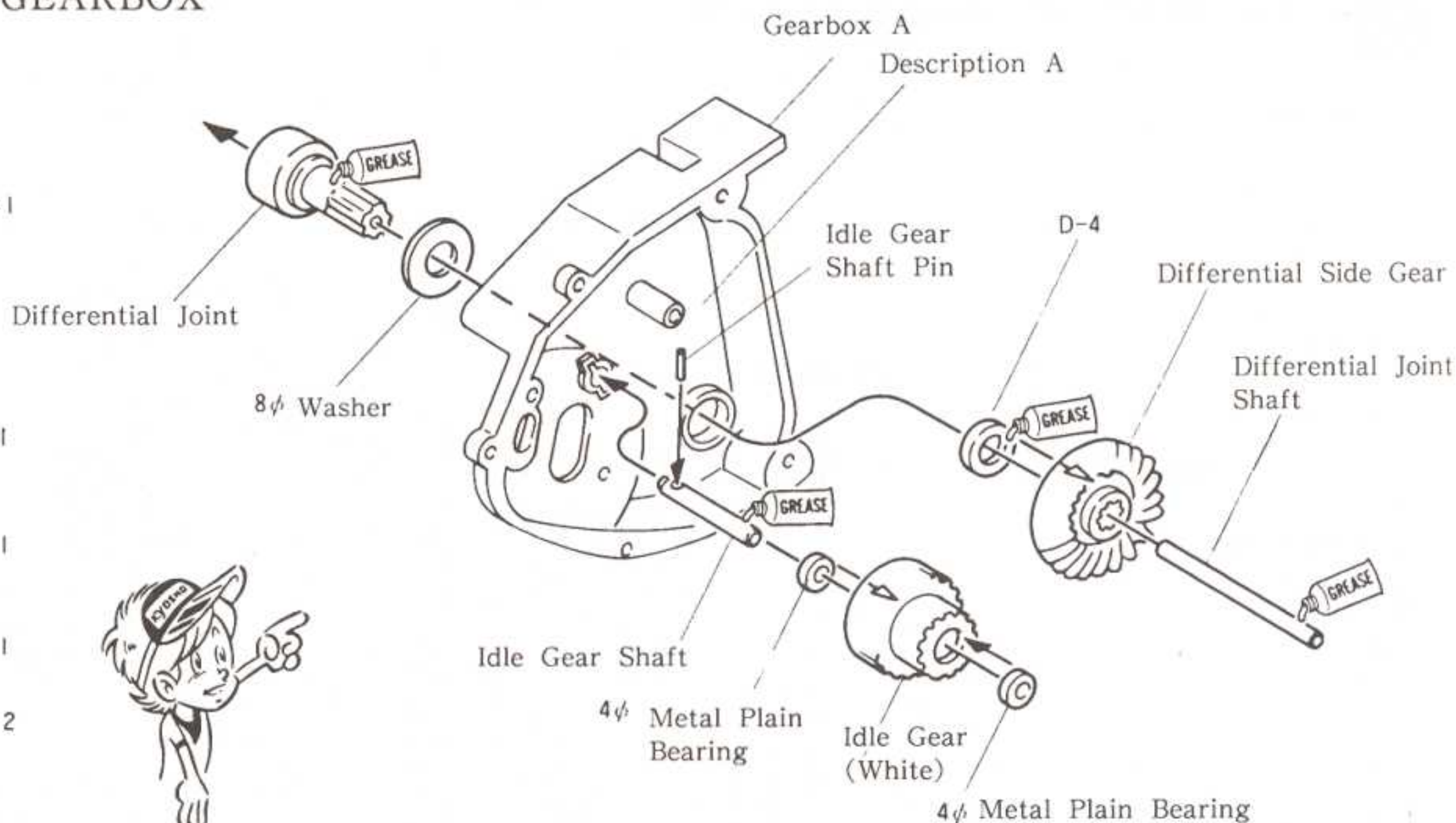

2 ASSEMBLY OF GEARBOX

M3x12 Self Tapping Screw

8φ Washer 1

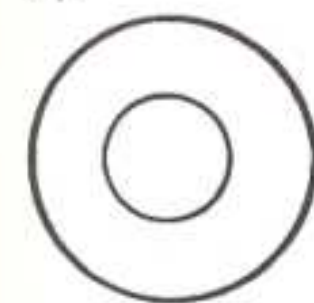

M3x12 TP Screws 4

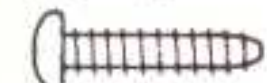

Counter Gear Shaft 1

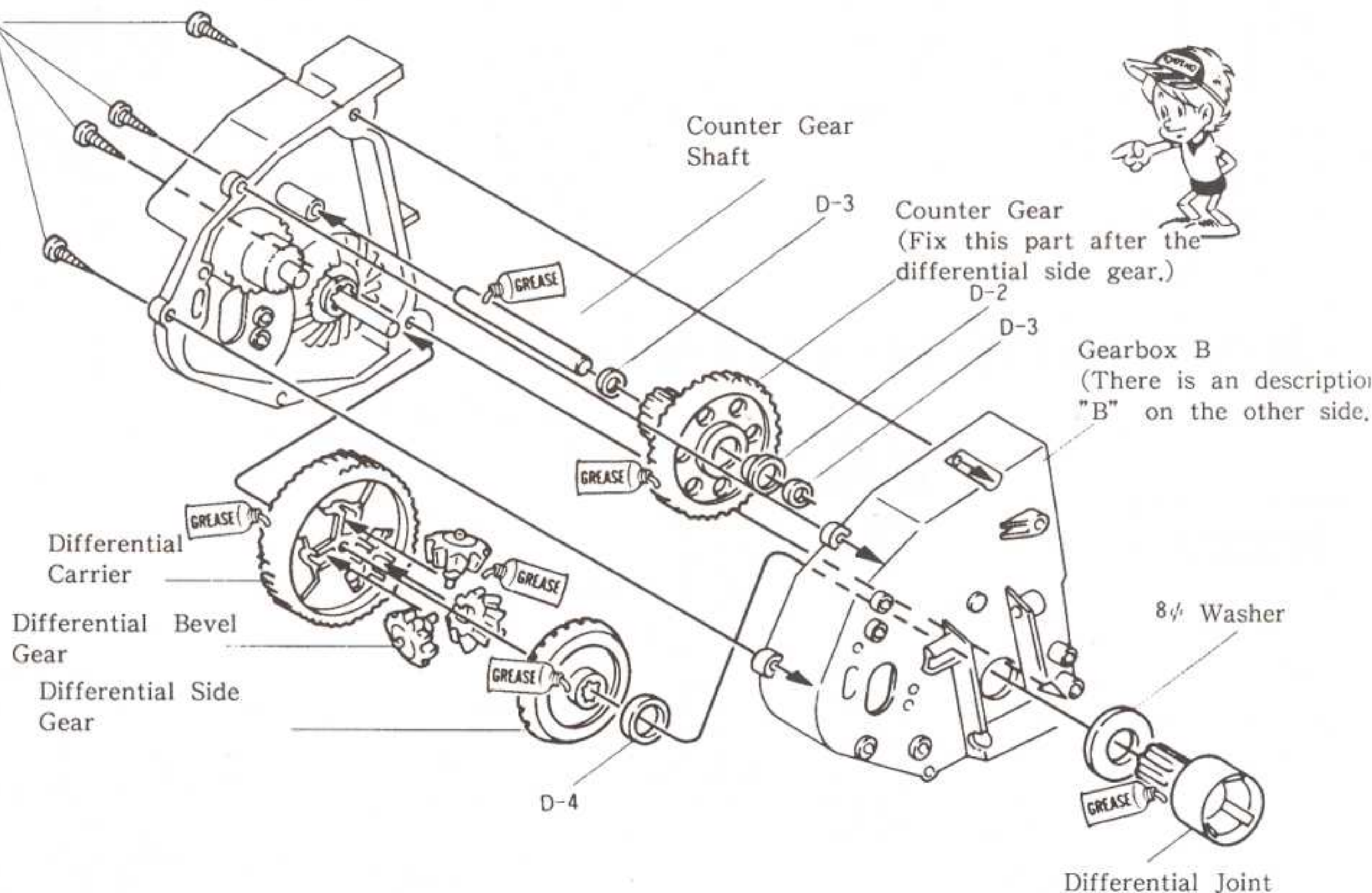

3 ASSEMBLY OF SUSPENSION ARM

M2x6 TP Screws 16

8φ Pillow Balls 8

8φ Ball Seats 8

5φ Plastic Bearings 8

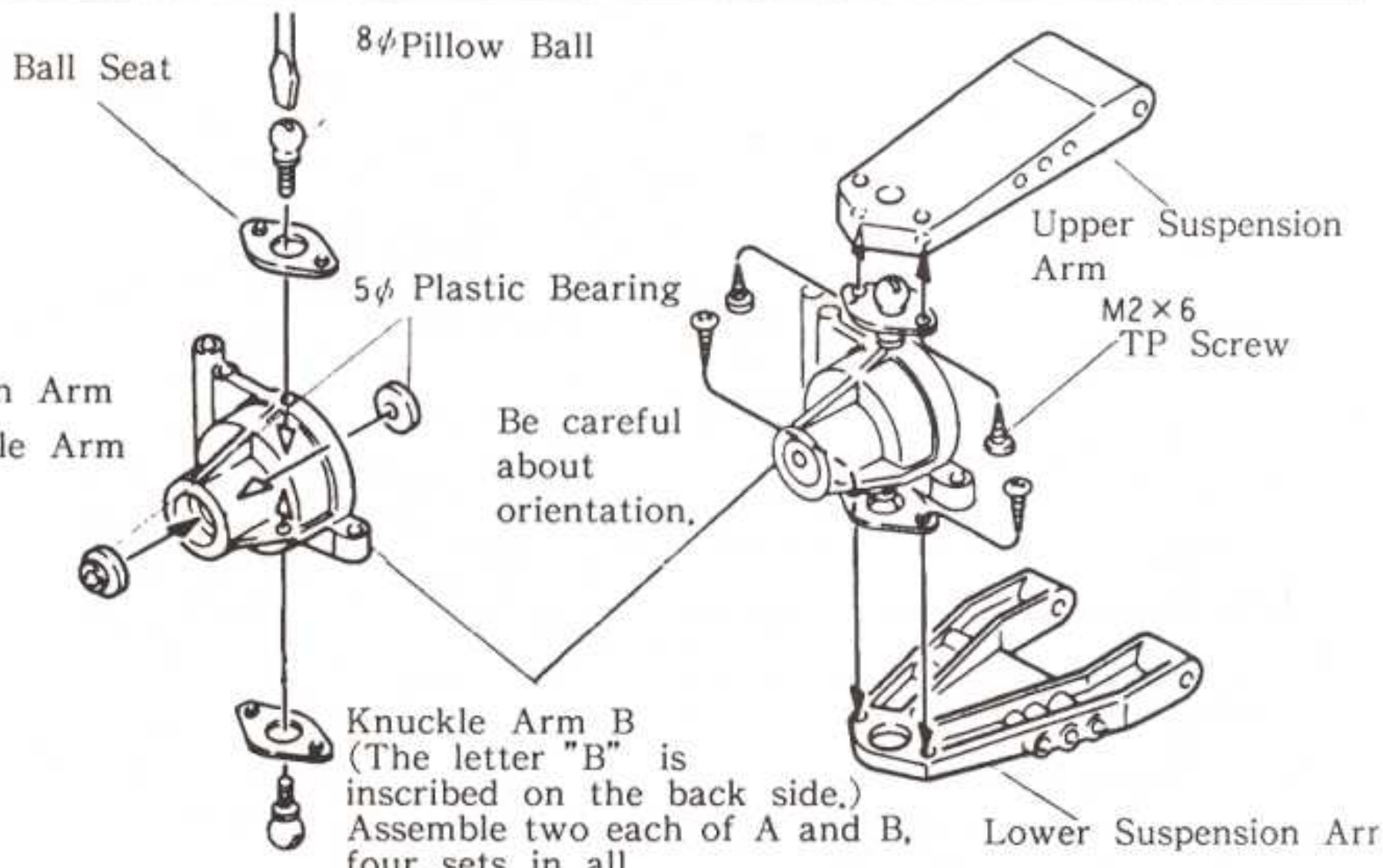
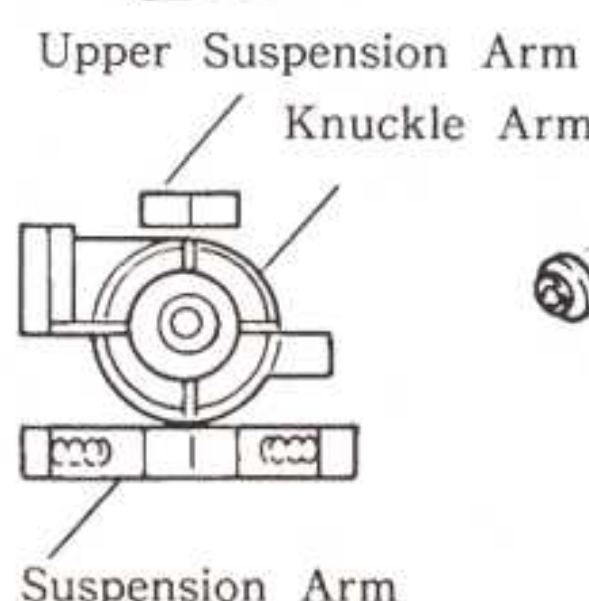
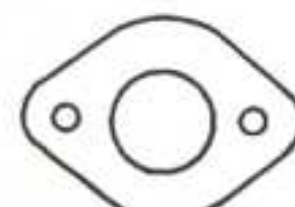

6 HOW TO CHECK RADIO SYSTEM

Operate the radio control units in order of the numerical figures.

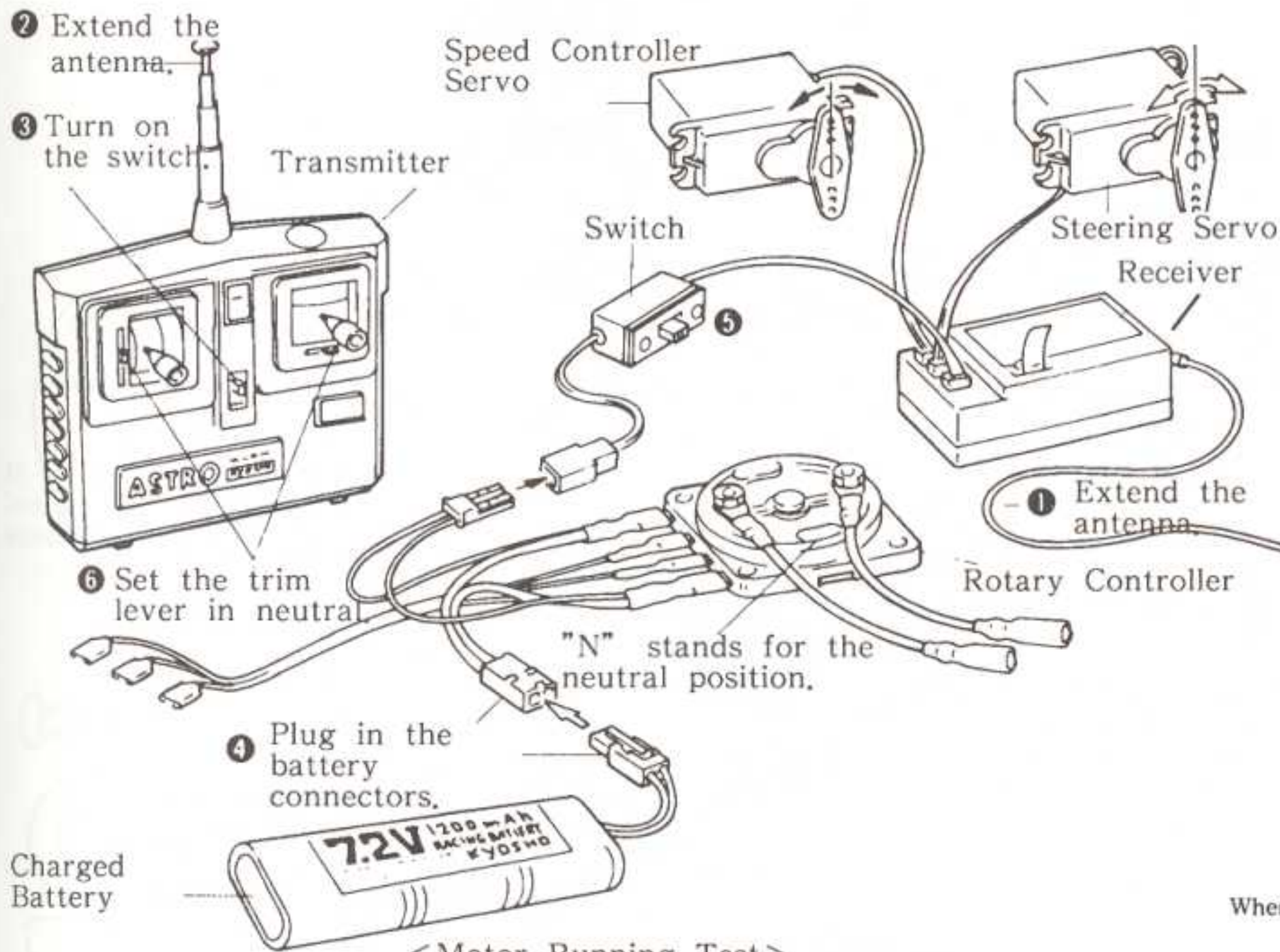

<Motor Running Test>

Before plugging in the battery connectors, confirm the speed controller is set in neutral,



This model is for BEC system radio only.

A two channel radio is composed of things like a transmitter, receiver, servos, and battery.

- Transmitter----- It is effect a control box. Signal waves are transmitted through an antenna according to the stick movements.
- Receiver ----- Receives the signals from the transmitter and send them to the servos.
- Servo ----- They really move the control mechanism of a model car in accordance with the signals from the receiver.
- Antenna----- An antenna on the transmitter sends signals, and one on the receiver accepts them. They should be fully extended.
- Trim Lever----- They will adjust the neutral position of servos, thus regulate the steering and advancing controls finely.
- Battery ----- You can tell the amount of electricity in a battery and how the signals are emitted.
- Servo Horn----- They are intermediate devices on the servos to activate the controls. There are several types in shape. They should be selected depending upon the usage.

When switch on the radio...

Get the switches in order from transmitter to receiver.

When switch off the radio...

In order from receiver to transmitter.

7 ASSEMBLY OF SPEED CONTROL SERVO

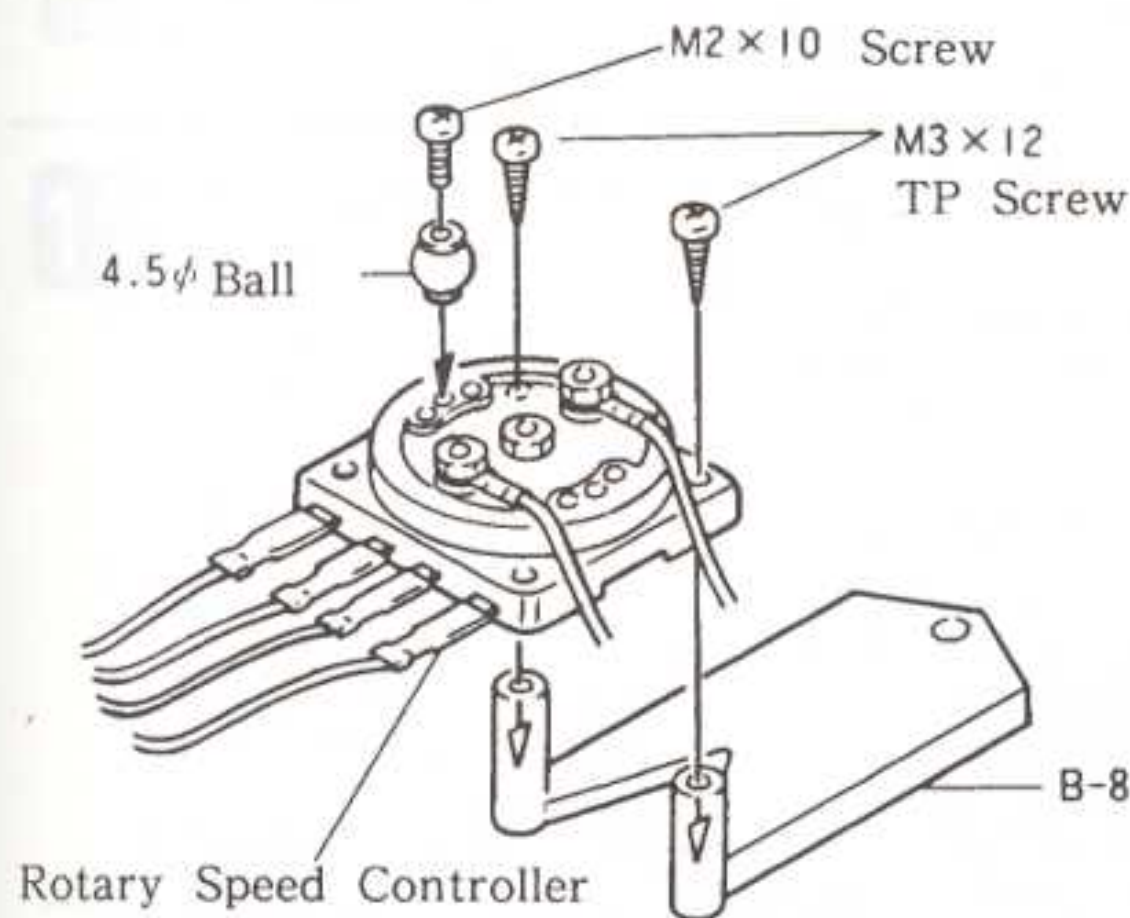

<Actual Size>

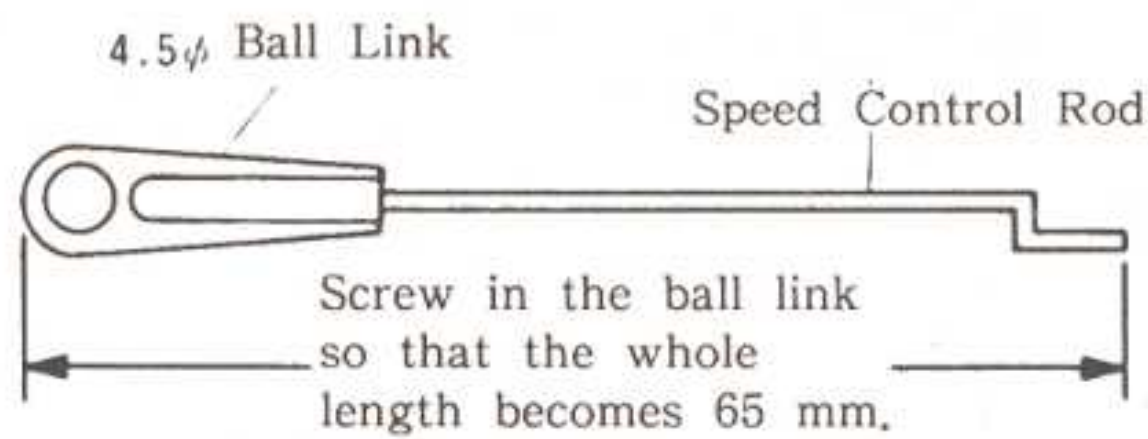

Cut off the shaded area.

Trim the arm into the shape as shown.

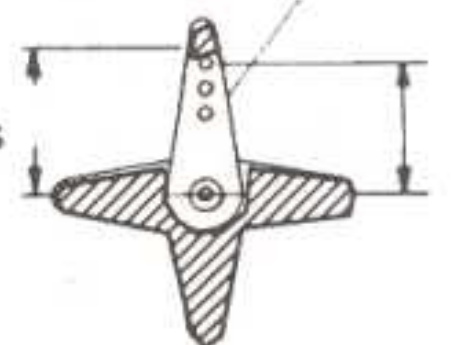

Insert speed control rod into a 12mm dia. hole.

Servo Horn, which came with your radio control units.

A screw which was used to fix the servo horn.

Angle in 90°

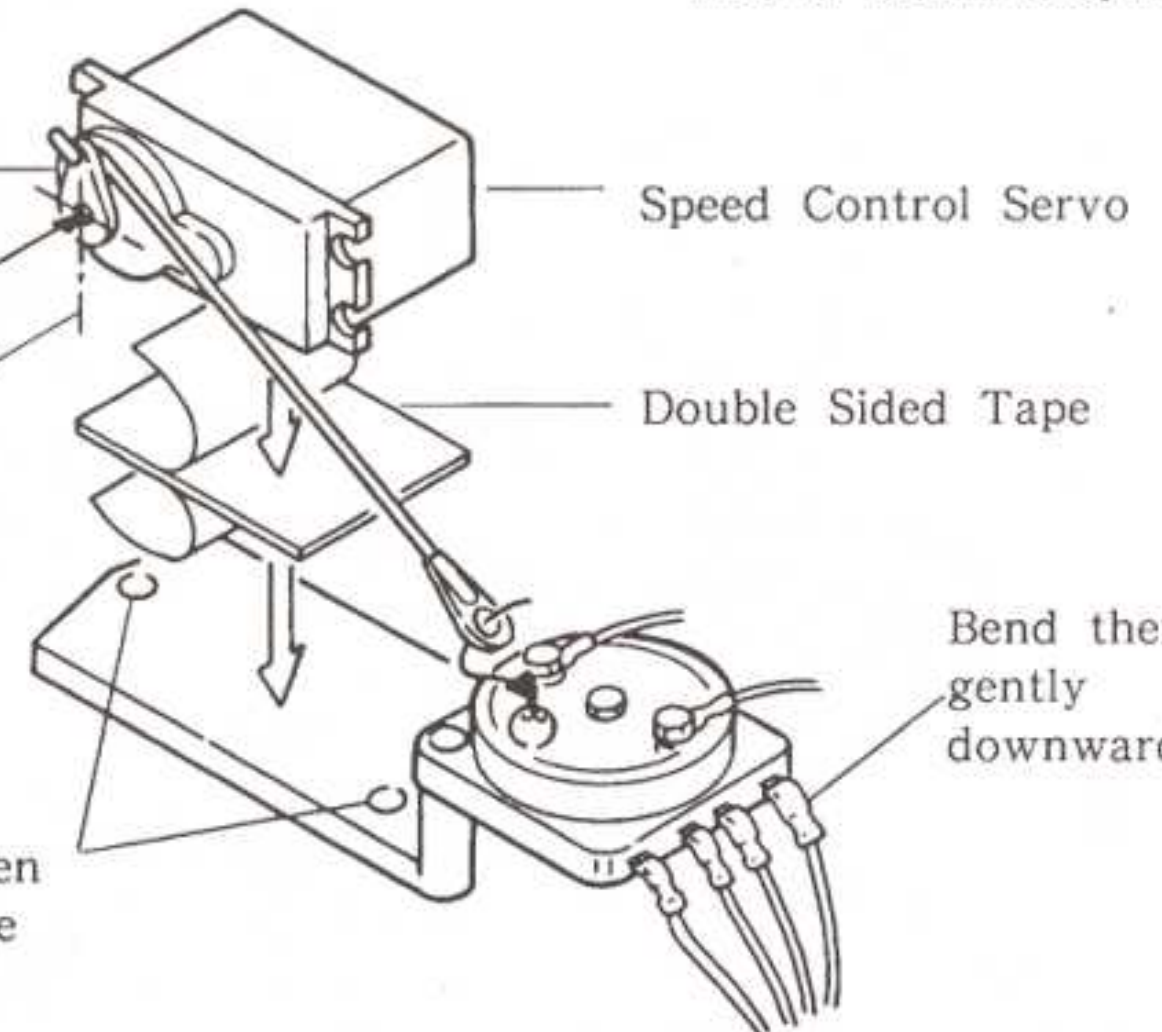

Care should be taken not to cover up the holes.



- Double Sided Tape 1
- 40
- M3 x 12 TP Screws 2
- M2 x 10 Screw 1
- 4.5φ Ball 1
- 4.5φ Ball Link 1
- Speed Control Rod 1

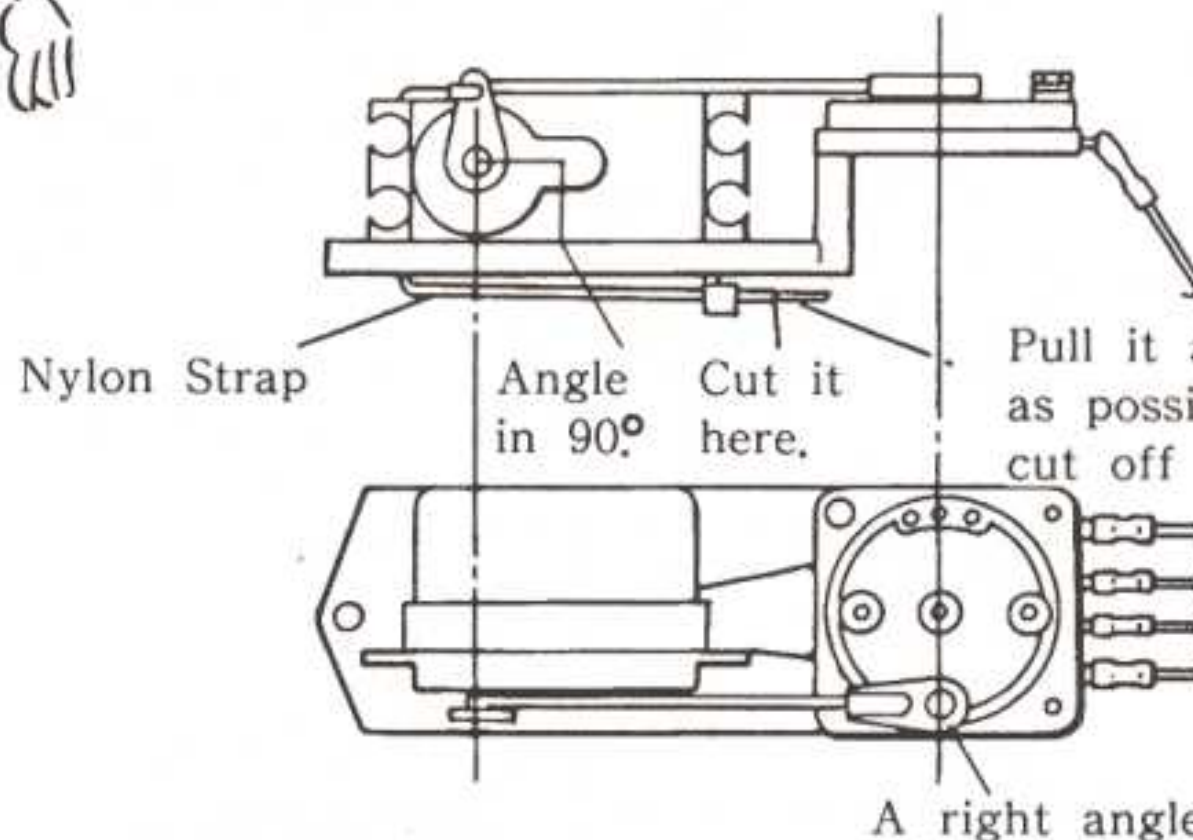

10 INSTALLATION OF THE ROD

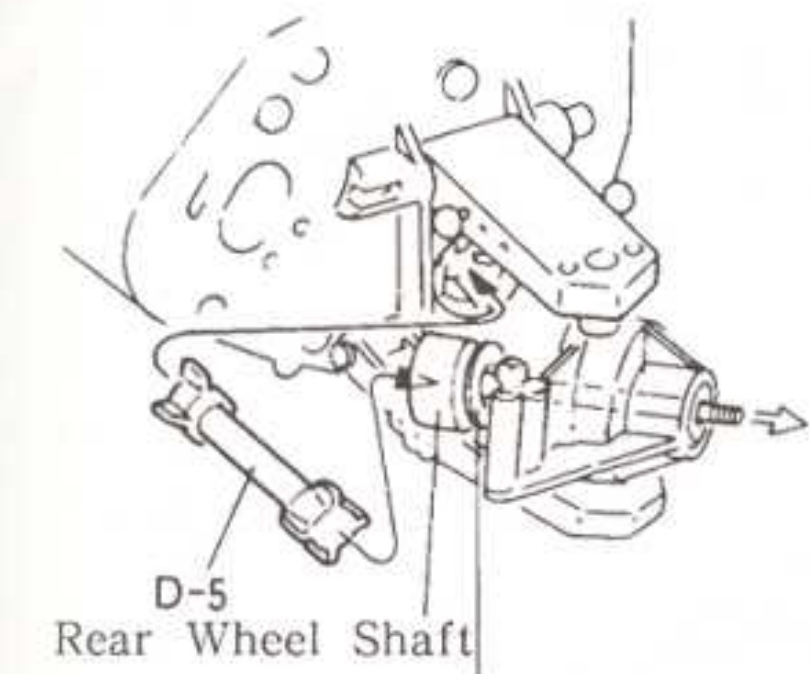

If you have any difficulty to install the D-5, remove the suspension shaft A once.

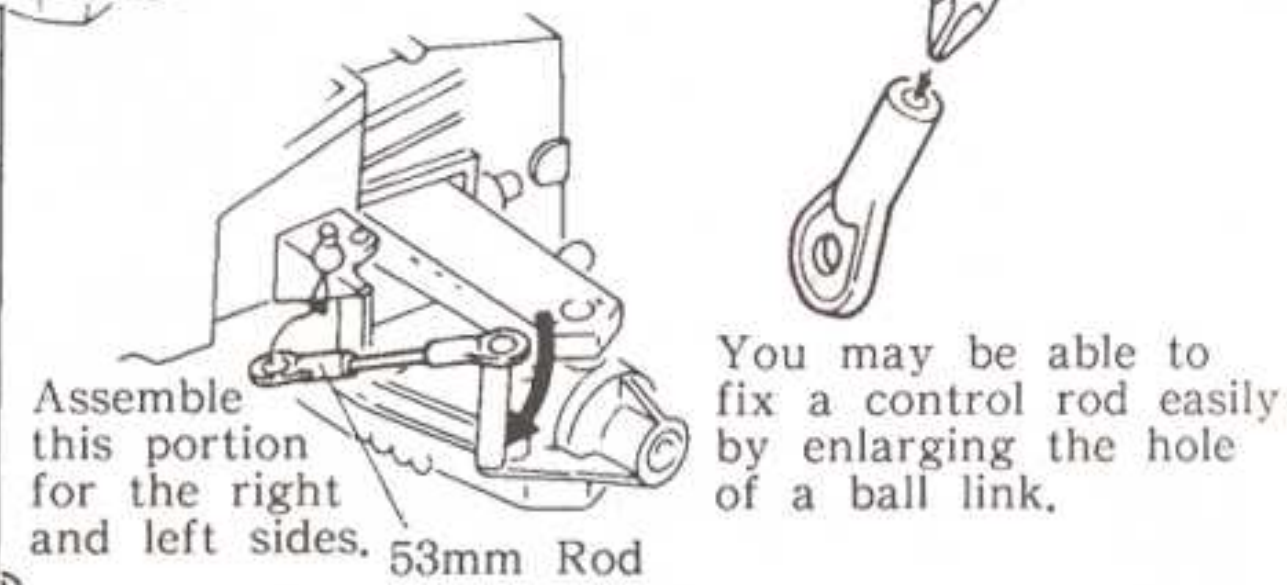
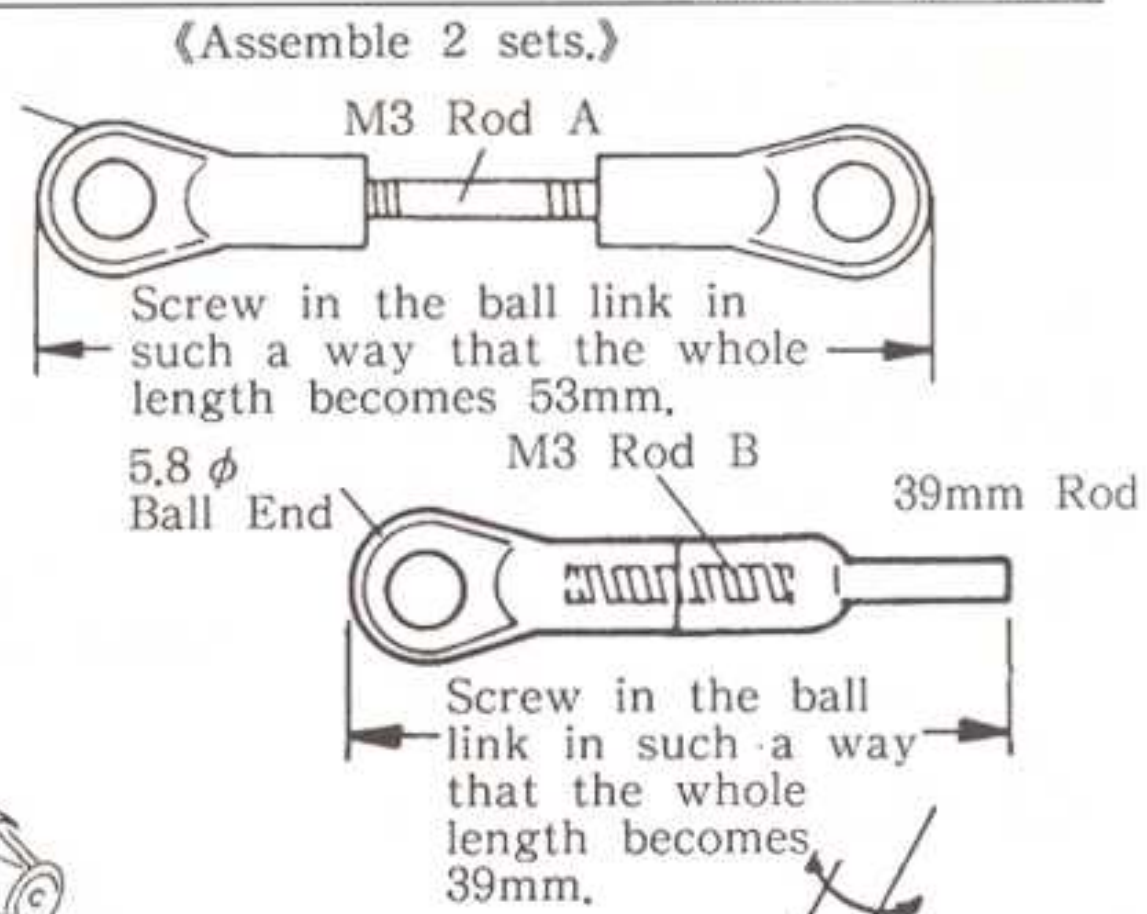
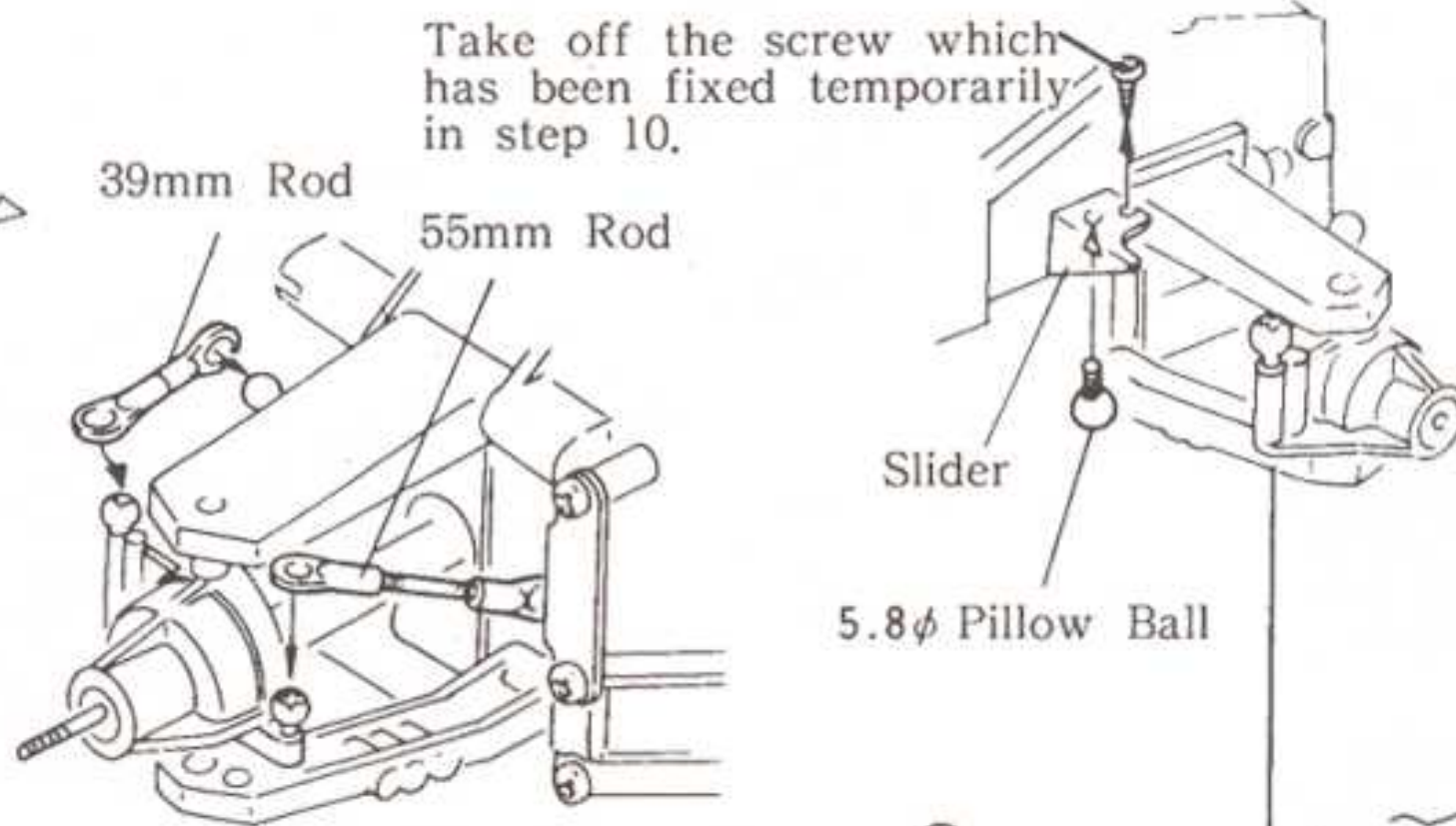
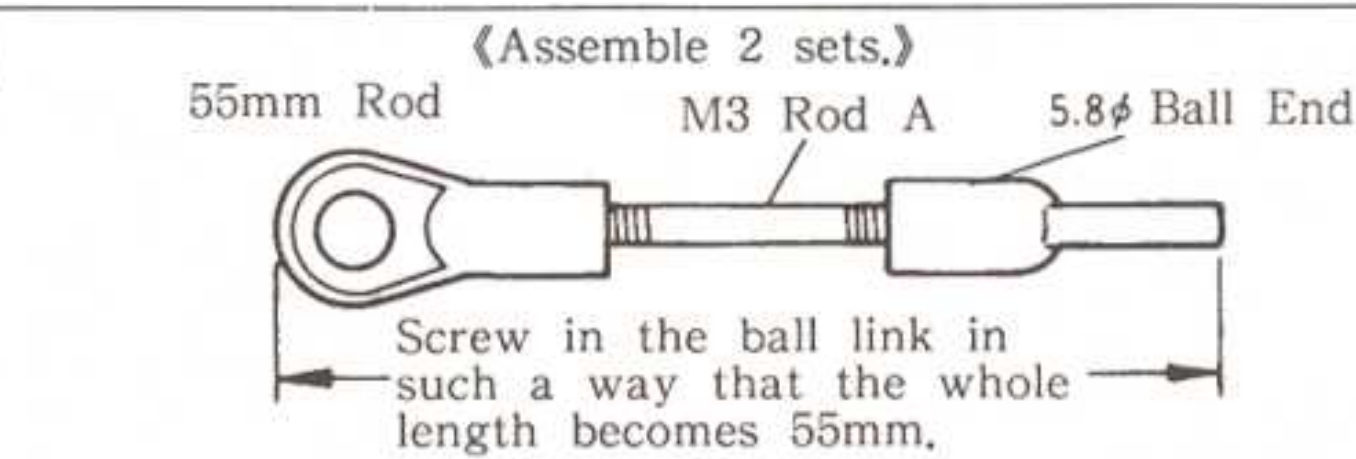

- M3x28 Screws... 2
- 5φ Washers 2
- Rear Wheel Shafts 2
- 5.8φ Ball Links 12
- M3 Rods A 4

- Knuckle Collar
- M3x28 Screw
- 5.8φ Pillow Balls 2
- M3 Rods B 2
- Knuckle Collars... 2



11 ASSEMBLY OF FRONT GUARD

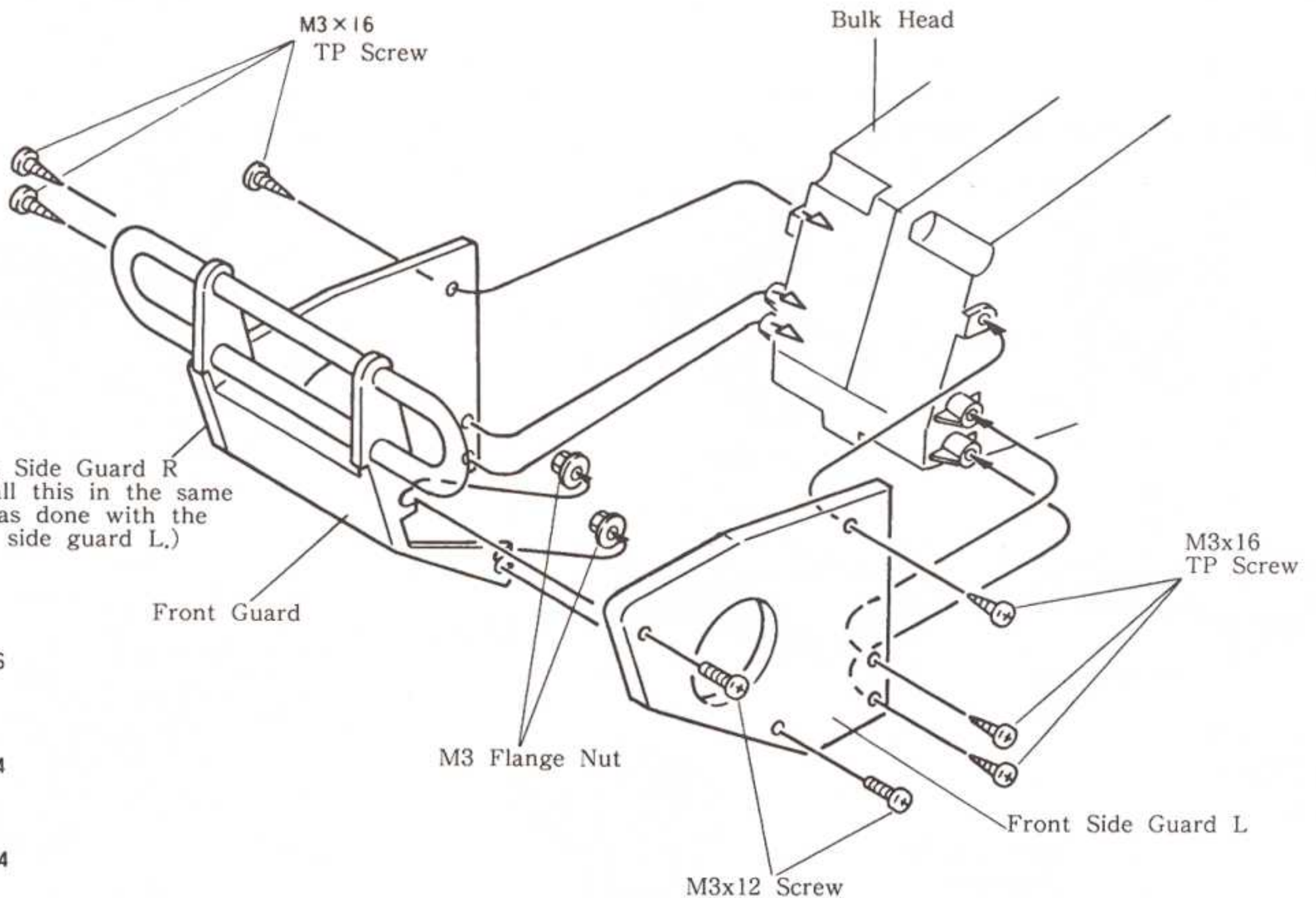

- M3×16 TP Screws... 6
- M3×12 Screws..... 4
- M3 Flange Nuts 4
- M3×16 TP Screws..... 4

12 INSTALLATION OF REAR GUARD

*This is the gearbox for the end where the rotary speed controller is.

- M3x60 Screw 1
- M3x12 TP Screws 8
- M3 Nylon Nut 1

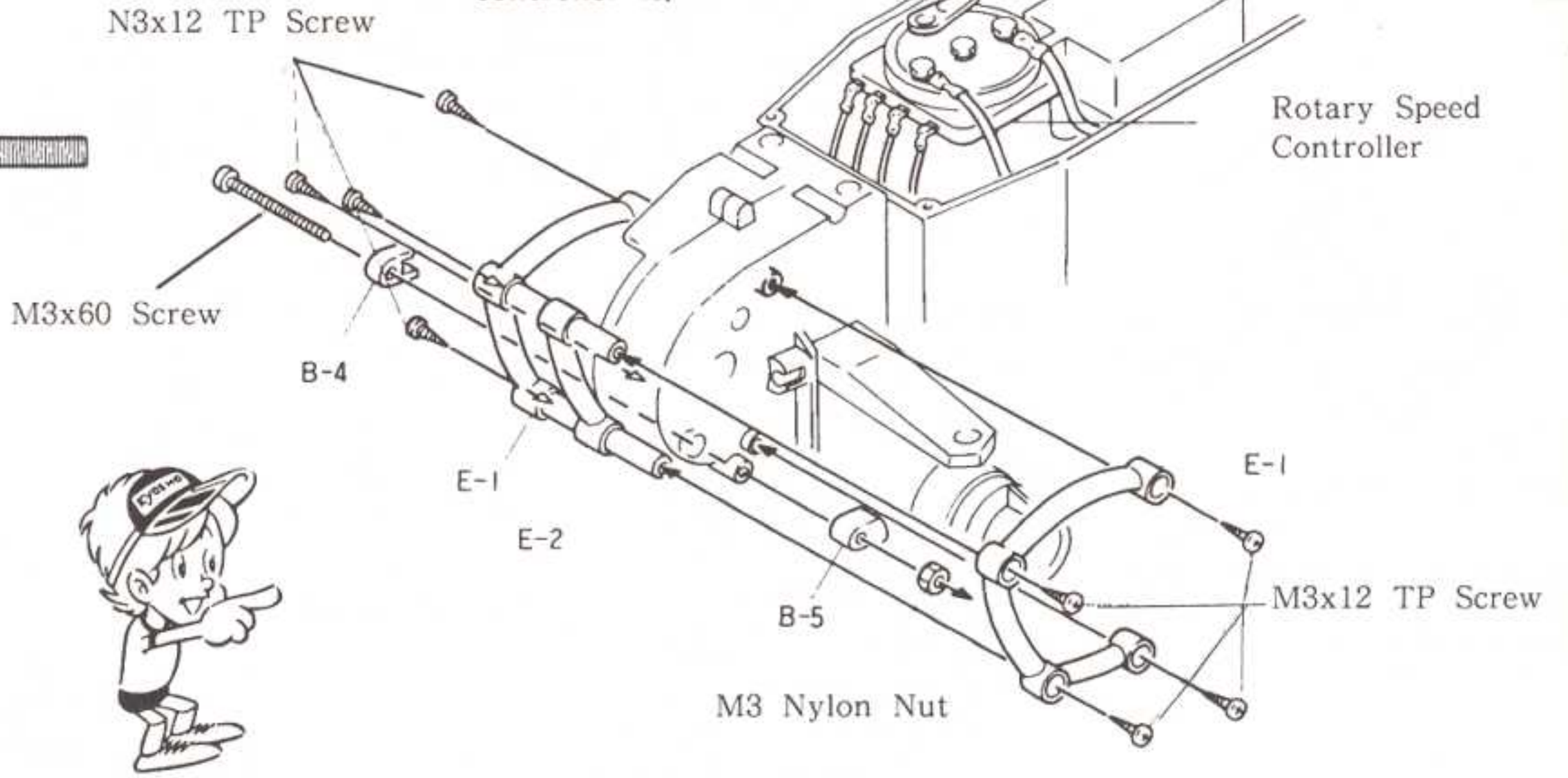

13 ASSEMBLY OF SHOCK

- M2x6 TP Screws ... 8
- Cut out rubber pipe as shown in the illustrations, ... 4
- Shock Shafts ... 4
- 5.8φ Ball Links ... 4

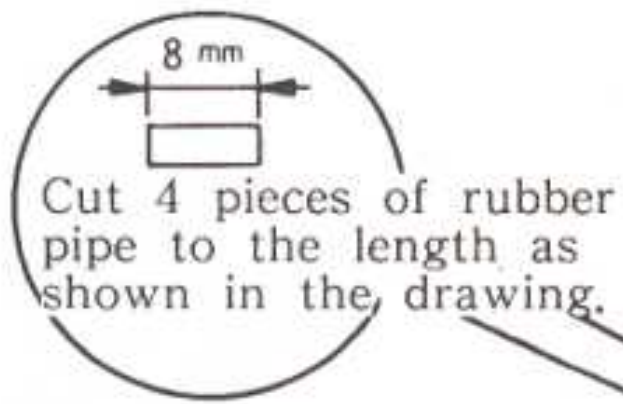

《Assemble 4 sets.》

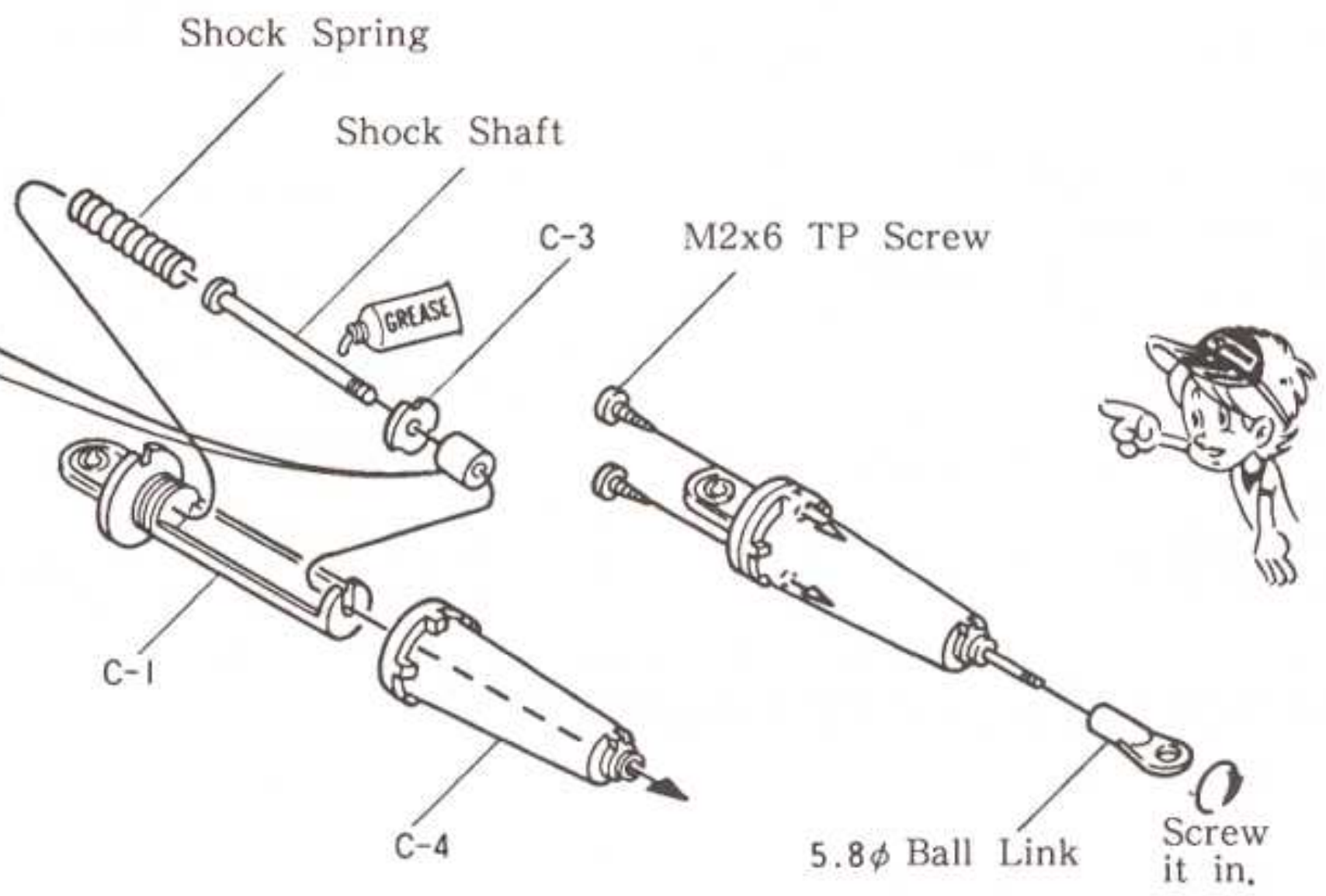

14 INSTALLATION OF SHOCK

- M3x16 TP Screws ... 6
- M3 Nuts 4
- M3 Flange Nuts ... 2
- M3x12 Screws 2
- M3x25 Screws 4

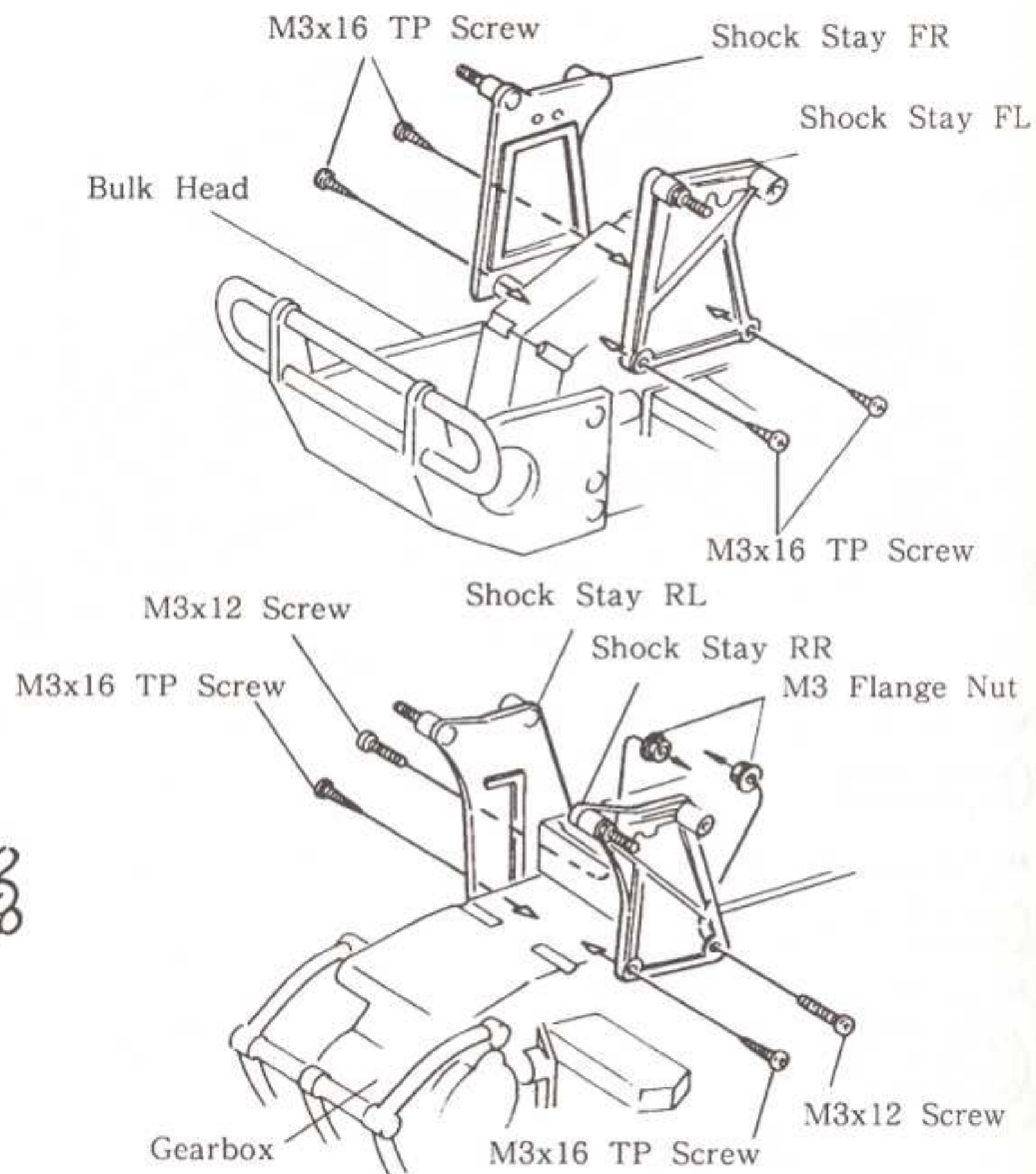
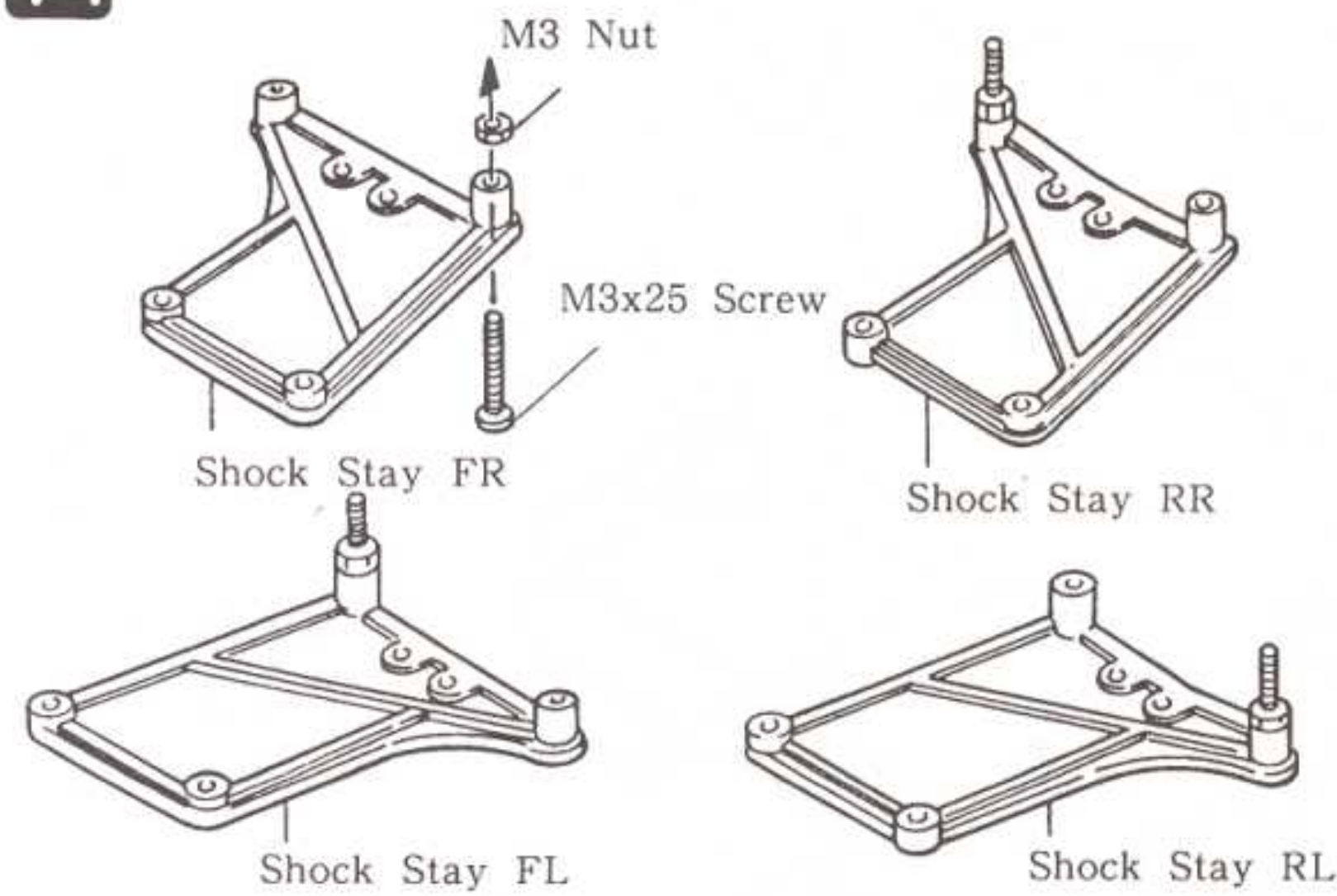

15 INSTALLATION OF SHOCK

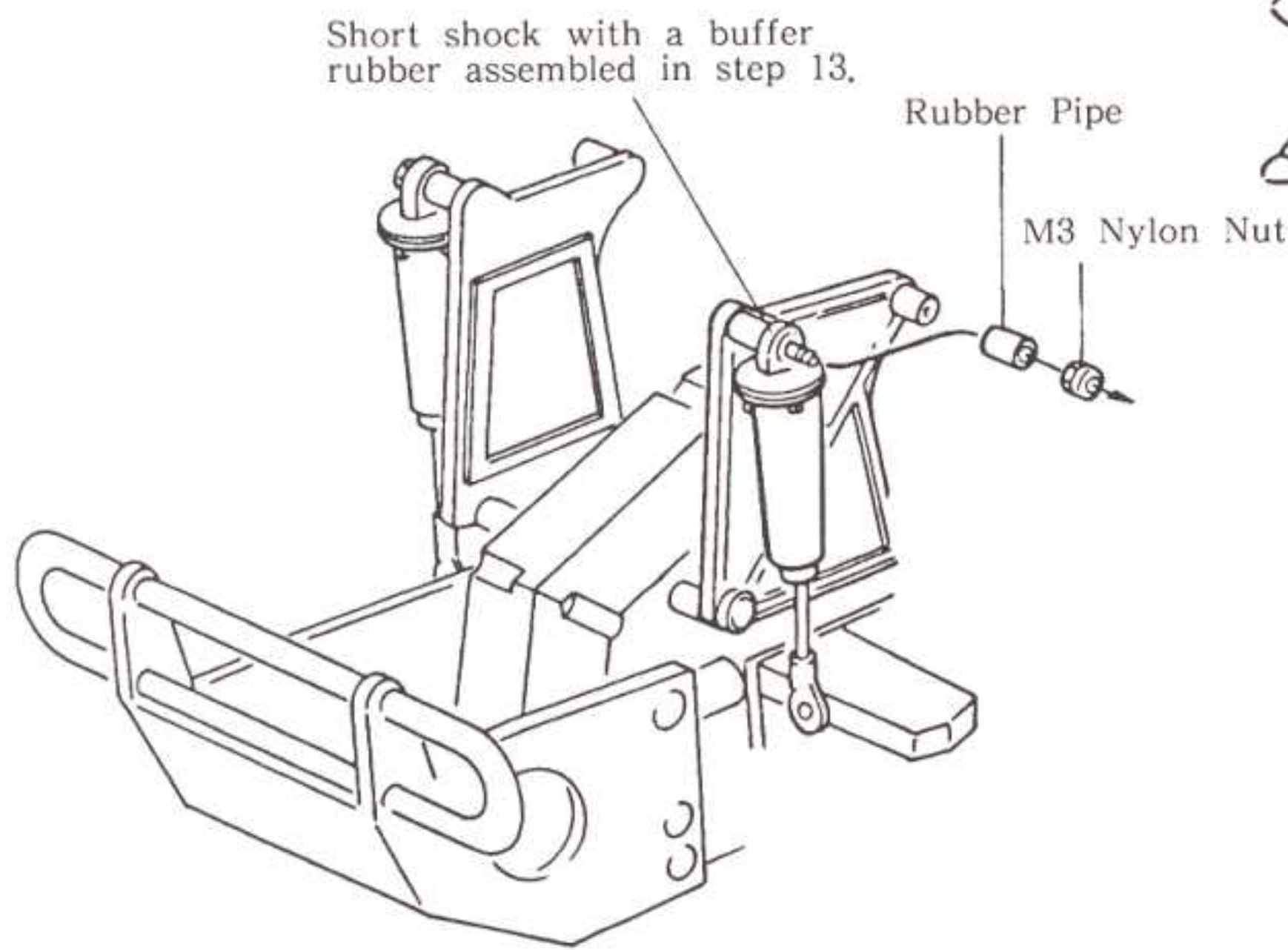

Cut off the rubber pipe to the length as shown.

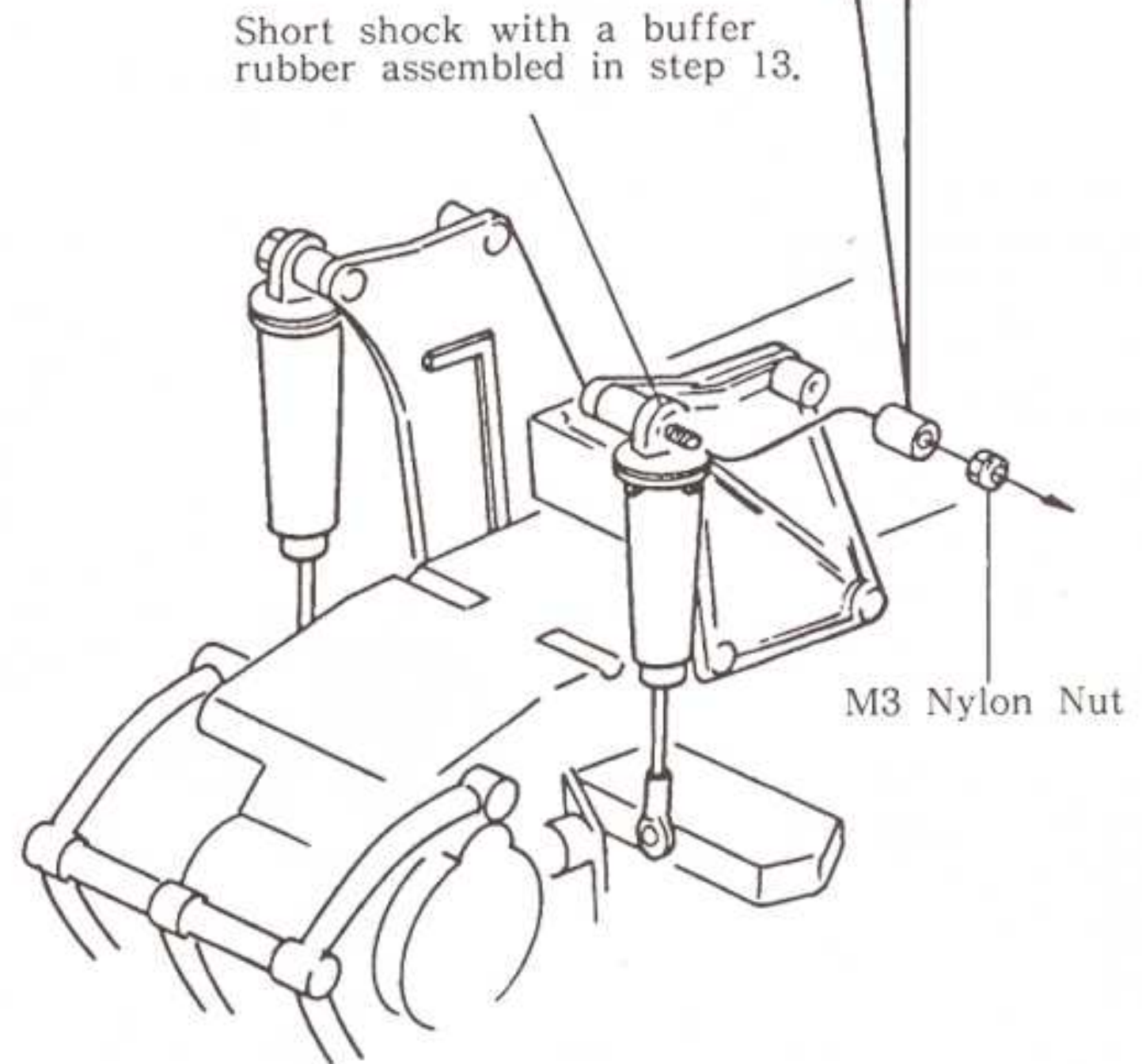
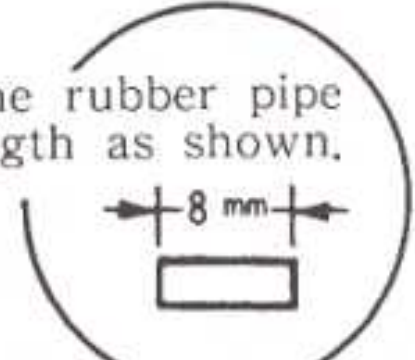

M3 Nylon Nuts 4



Rubber Pipes..... 4



16 INSTALLATION OF BATTERY GUARD



This is the end where the gearbox is installed (Rear)

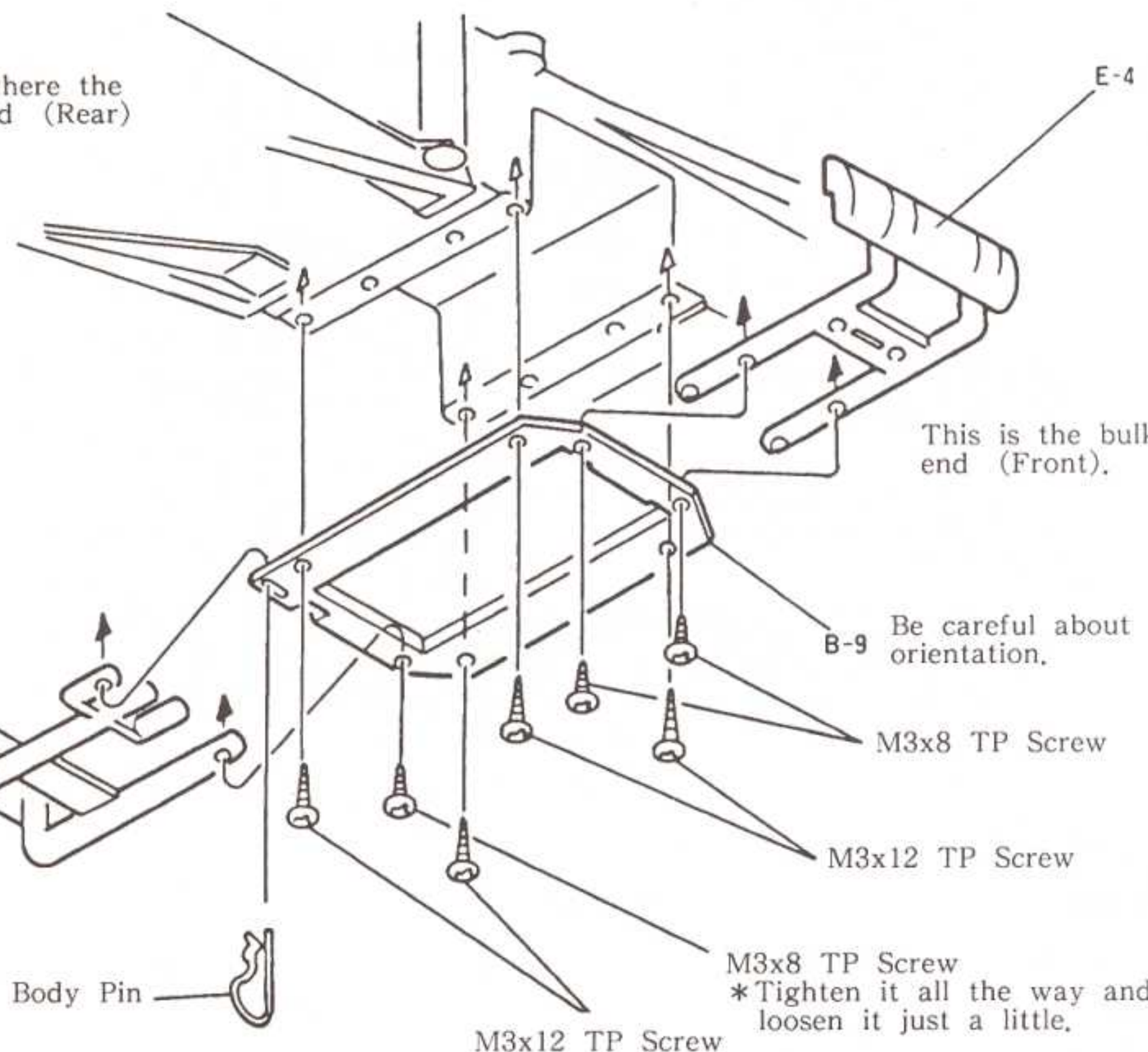

This is the bulkhead end (Front).

M3x12 TP Screws..... 4



M3x8 TP Screws..... 3

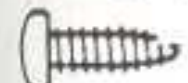

Body Pin 1



M3x8 TP Screw
*Tighten it all the way and loosen it just a little.

M3x12 TP Screw

17 INSTALLATION OF MOTOR

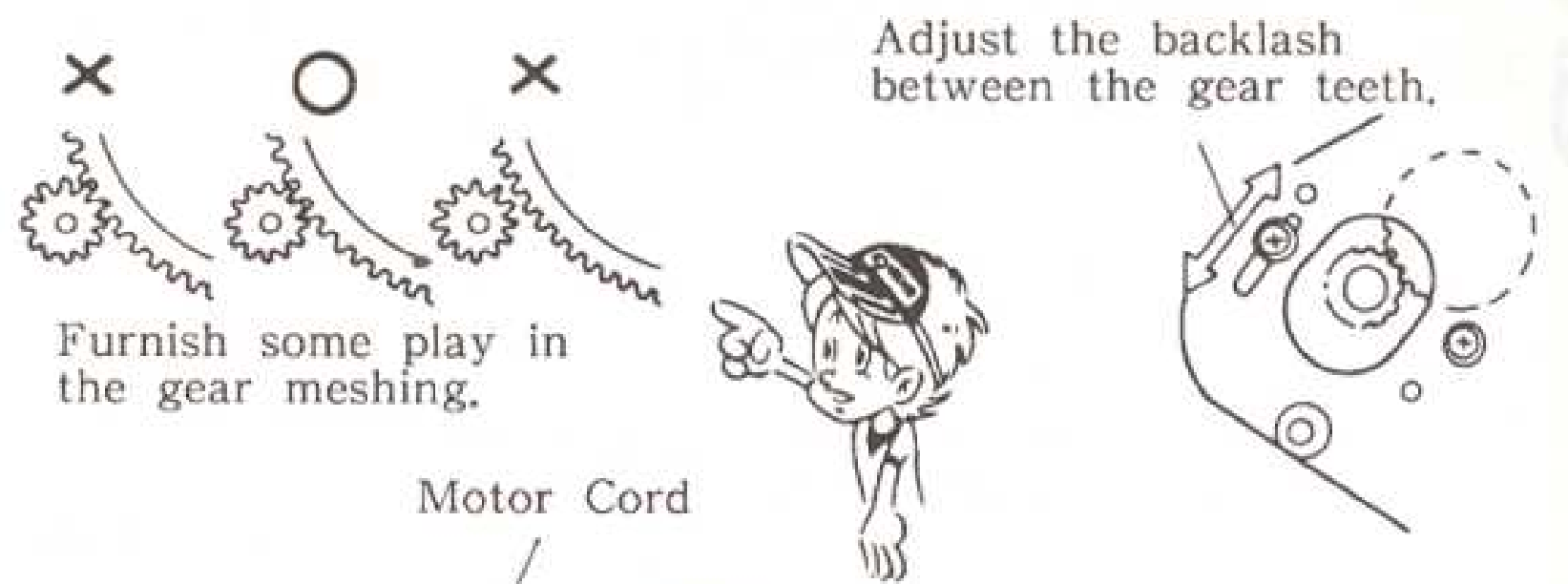
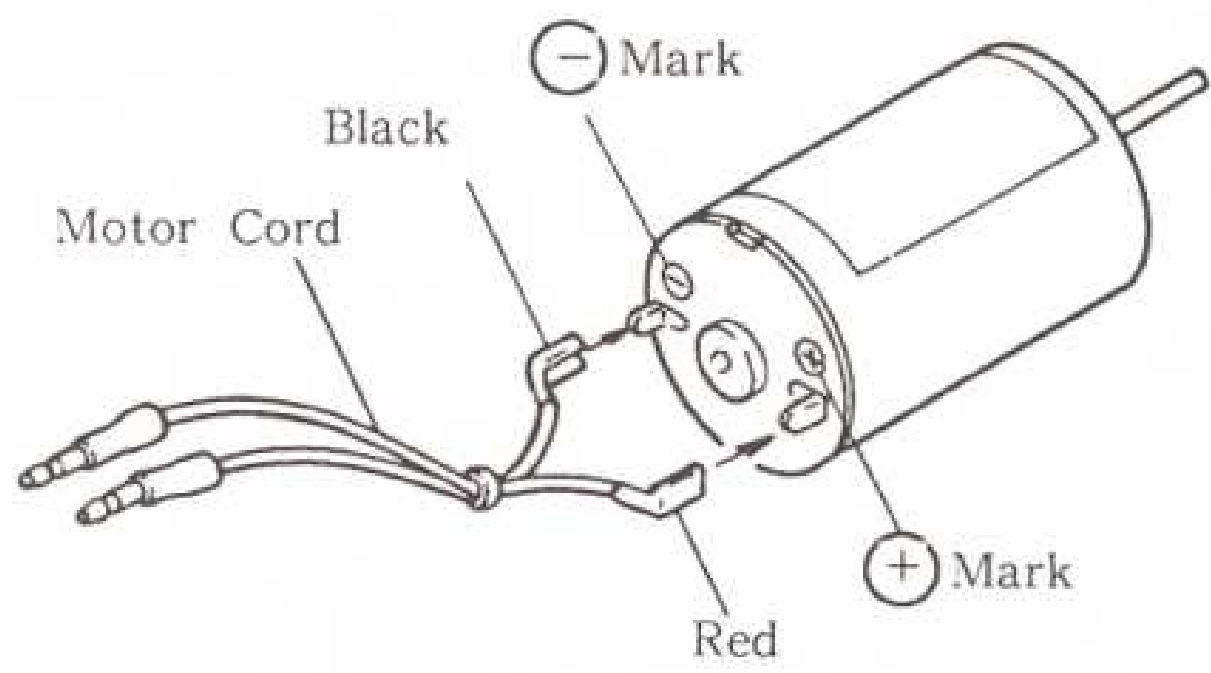

M3x28 Screws..... 2



M3x12 TP Screws..... 2



M3x3 Set Screw..... 1



3φ Washers 2



Pinion Gear (13T)..... 1

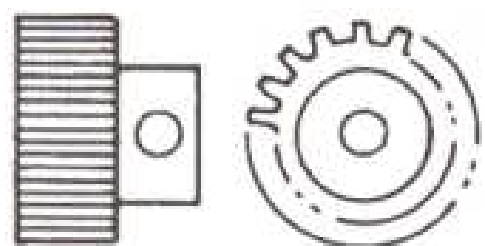

Cover the hole with the decal ①.

Le Mans Stock 05

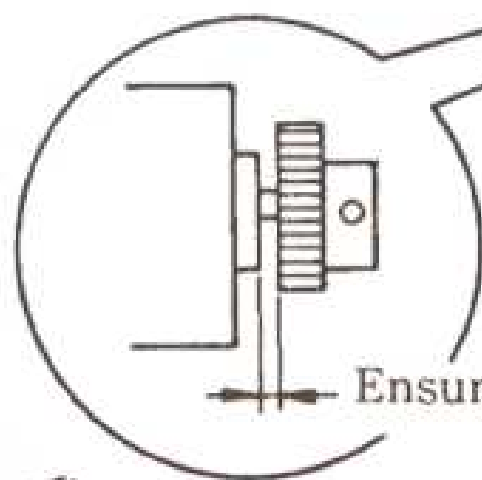

Hex Key

M3x3 Set Screw

3φ Washer

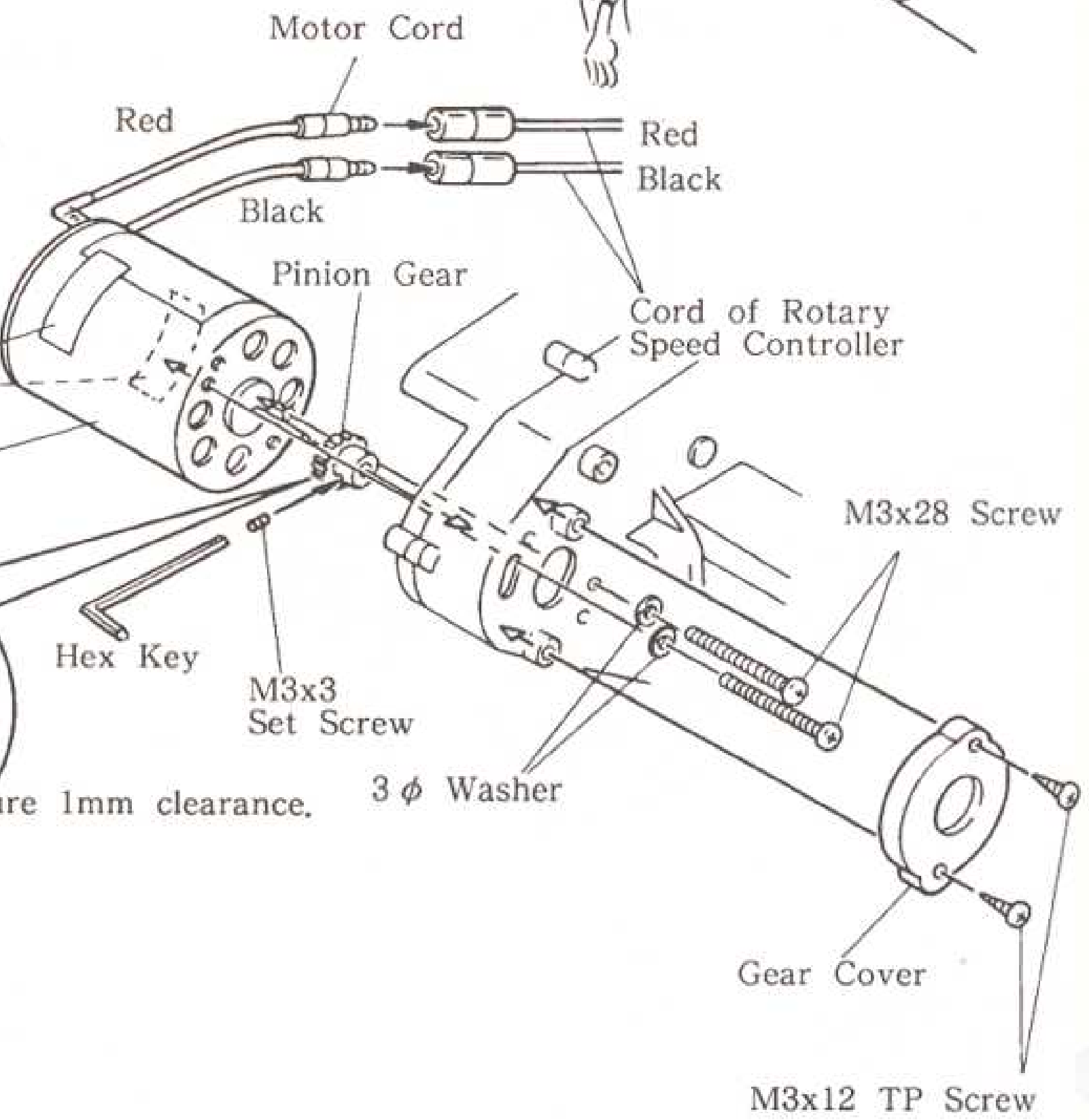

18 INSTALLATION OF COVER

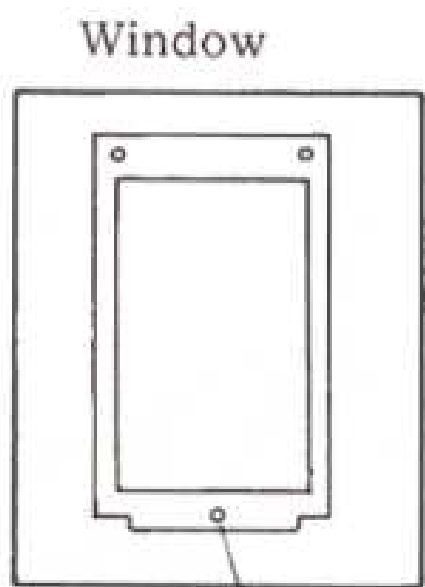

Cut out a perforation along with the cutout line and drill 3mm dia. holes at three points.

Bundle the leads together and tie them up with a vinyl string.

The red, black, thin yellow and thin red cords of the rotary speedcontroller and the receiver's antenna.



Remove the screw which was fixed in step 4, and fix the cover, then tighten the screw again.

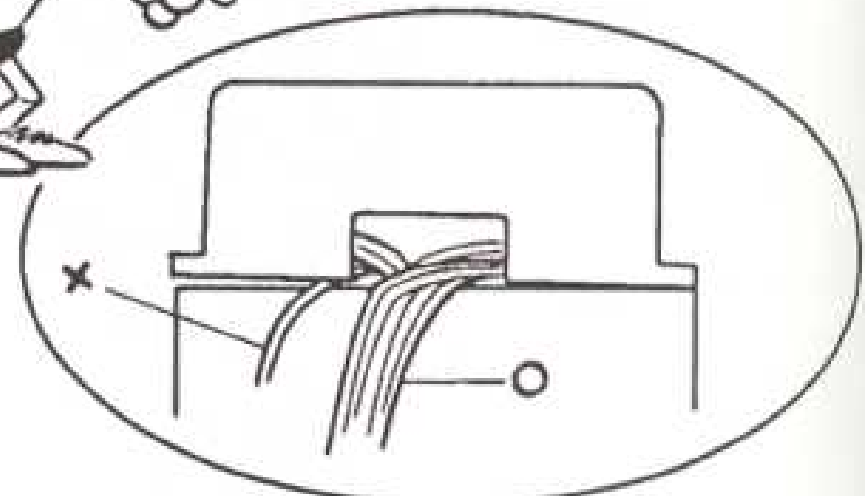

*Route all the cords in the notch on the cover. Take care that they are not caught between the cover and the main frame.

M3x12 TP Screws..... 8



M3x8 Screws..... 3



M3 Nuts..... 3

M3 Nut

Rotary Speed Controller 7.2V Connector

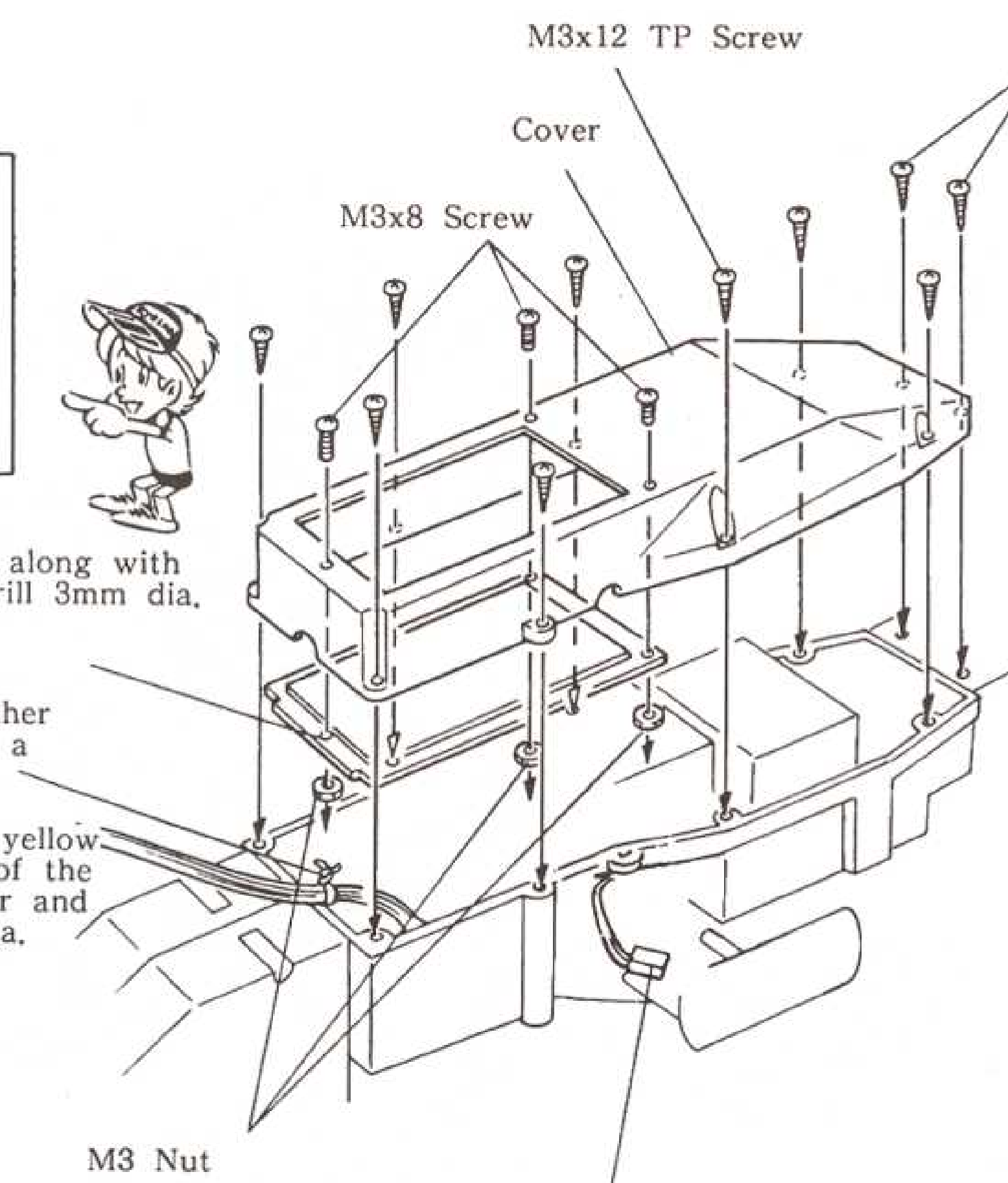

19 INSTALLATION OF BODY MOUNT

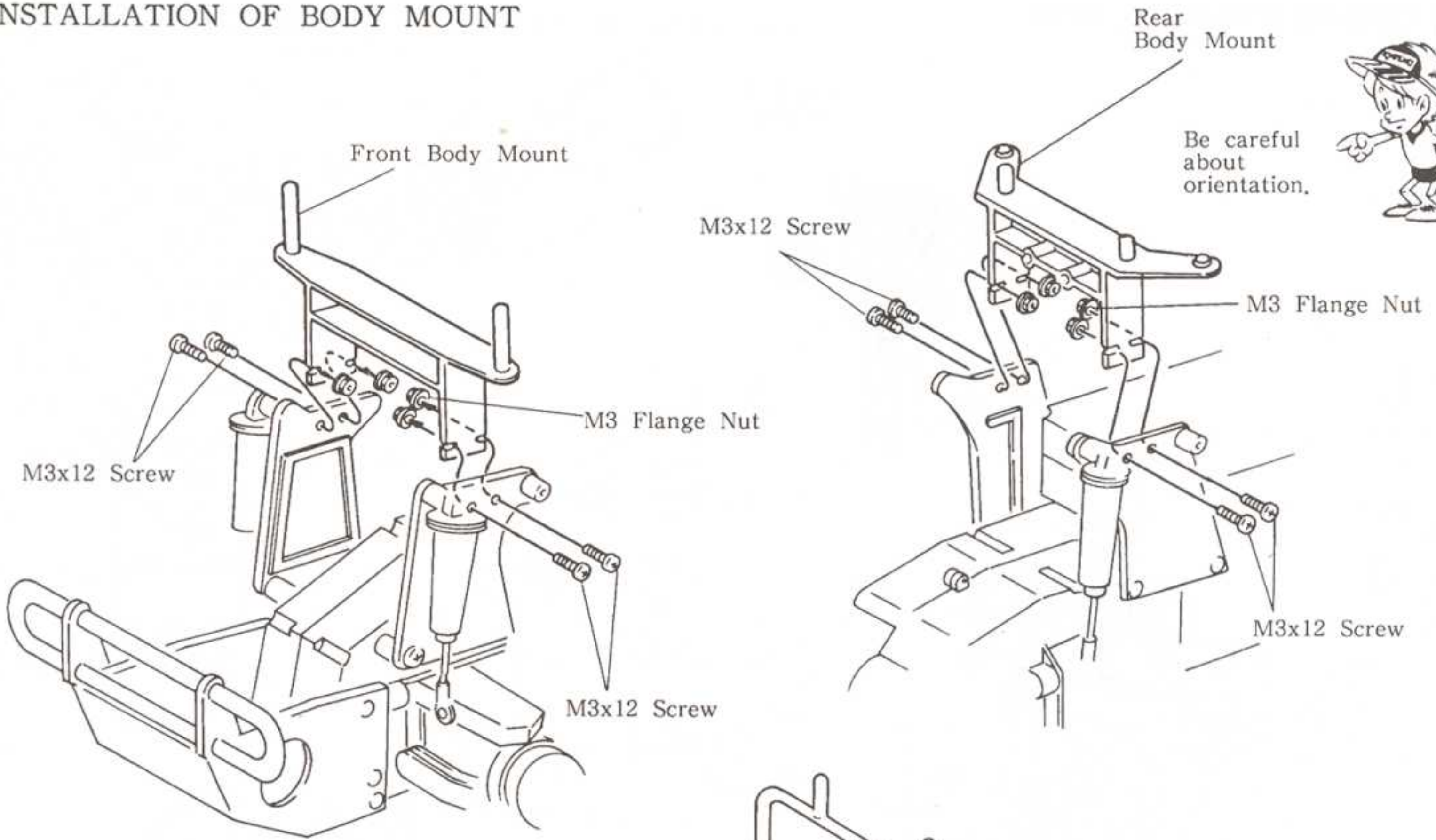

M3x12 Screws..... 8



M3 Flange Nuts..... 8

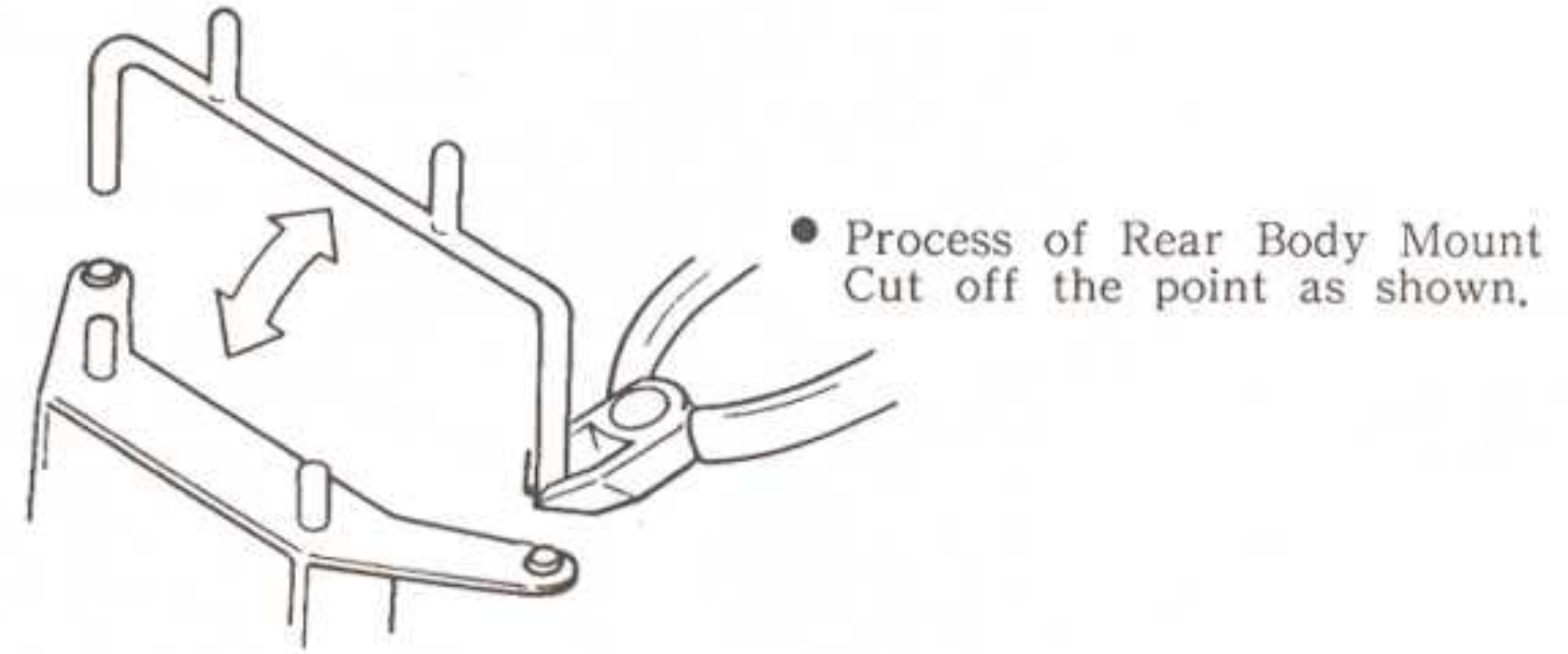

20 INSTALLATION OF RESISTOR

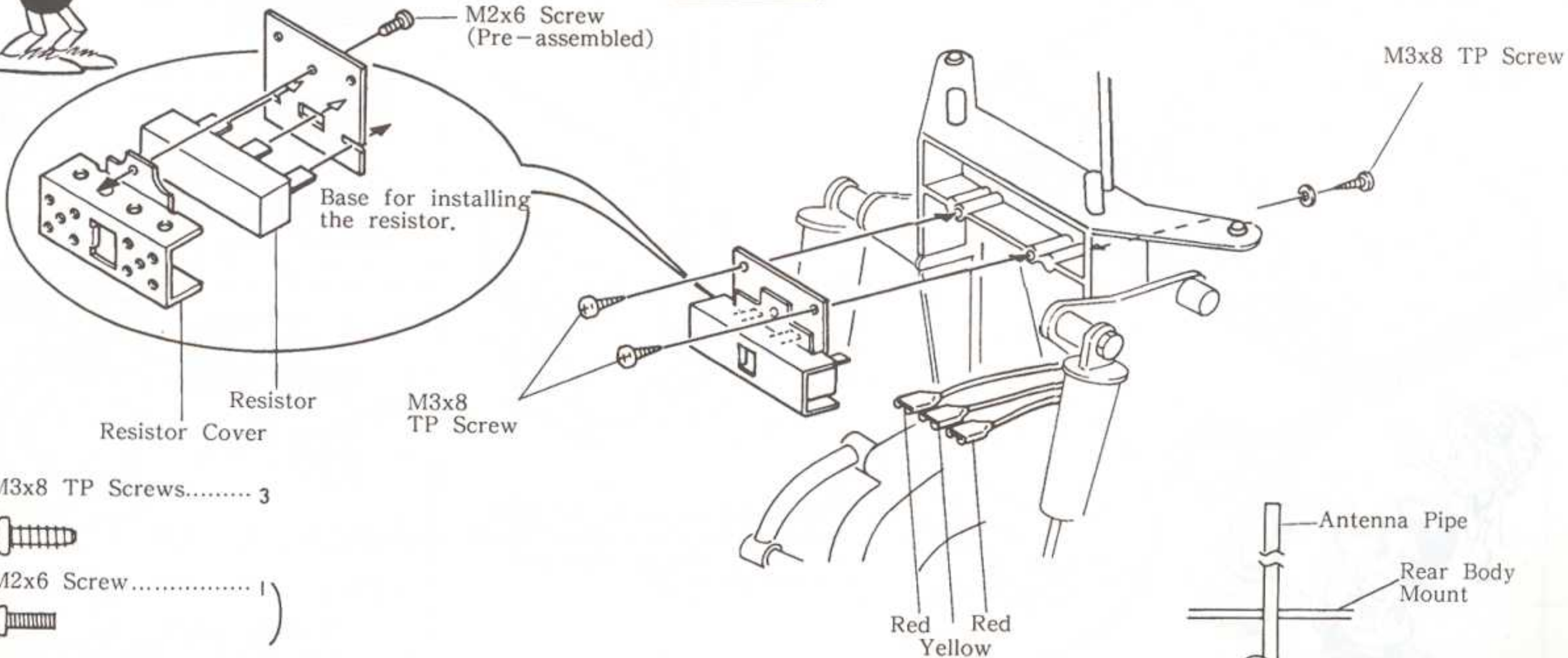
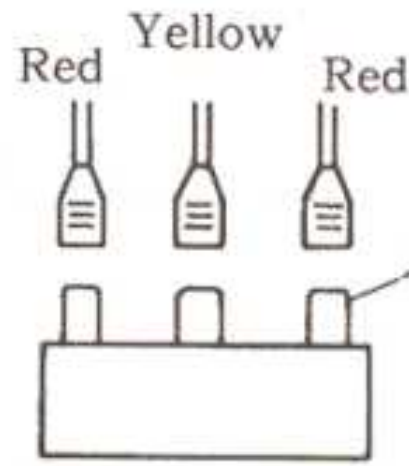

M3x8 TP Screws..... 3

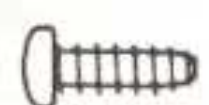

M2x6 Screw..... 1

3φ Washer..... 1

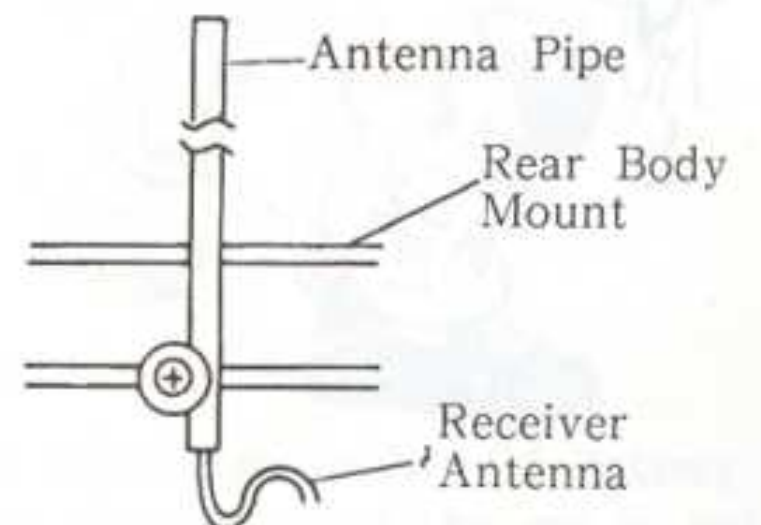

21 INSTALLATION OF TIRE

M3x8 TP Screws.....16

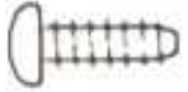

5φ Washers 6

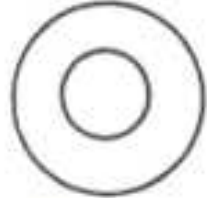

M4 Nylon Nuts 4



Wheel Shaft Pins 4



Wheel Hubs 4

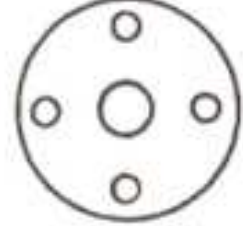

<For the left side wheel.>

*The tires for the left and right have inverted tread patterns.

Wheel B

<For the right side wheel.>

Wheel A (Plating)

Wheel B

M3x8 TP Screw

Disassemble the tire and the wheel, which have been put together in the kit, and reassemble them for Wheel A the right and left side, (Plating) set up two each for either sides.

Wheel C

Tire

Wheel A

Wheel B

M3x8 TP Screw

<Sectional View>

Fit the wheel A and B together aligning the installing holes.

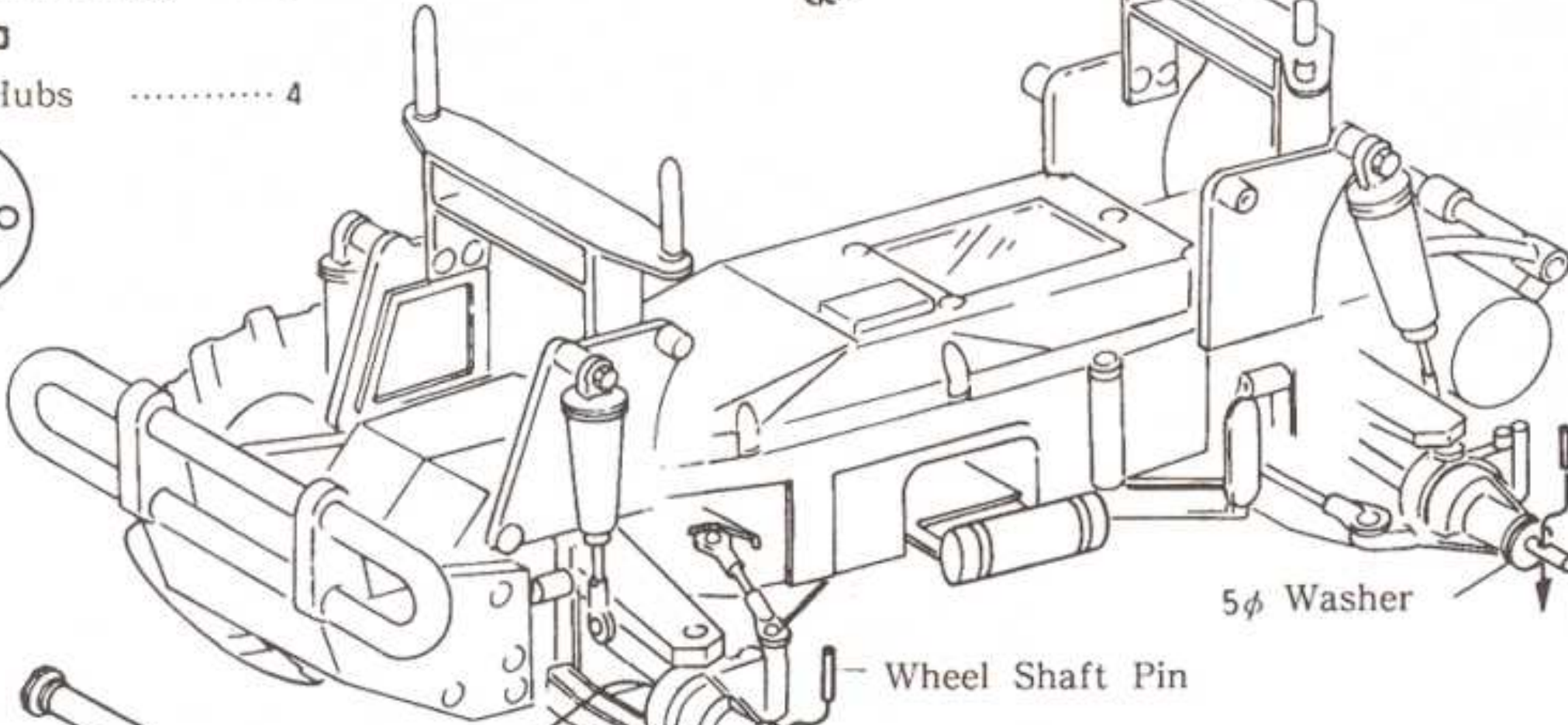

Wheel Shaft Pin

5φ Washer

Wheel Shaft Pin

Front Wheel Shaft

5φ Washer

5φ Washer

Wheel Hub

M4 Nylon Nut

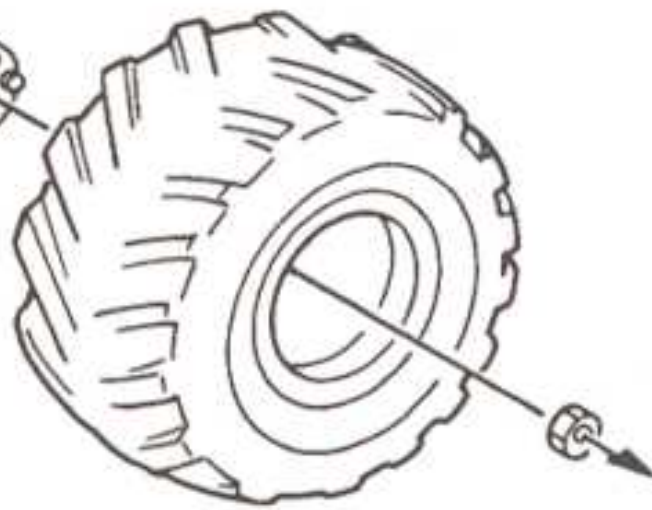

* Assemble all four places in the same way.

Front Wheel Shafts 2

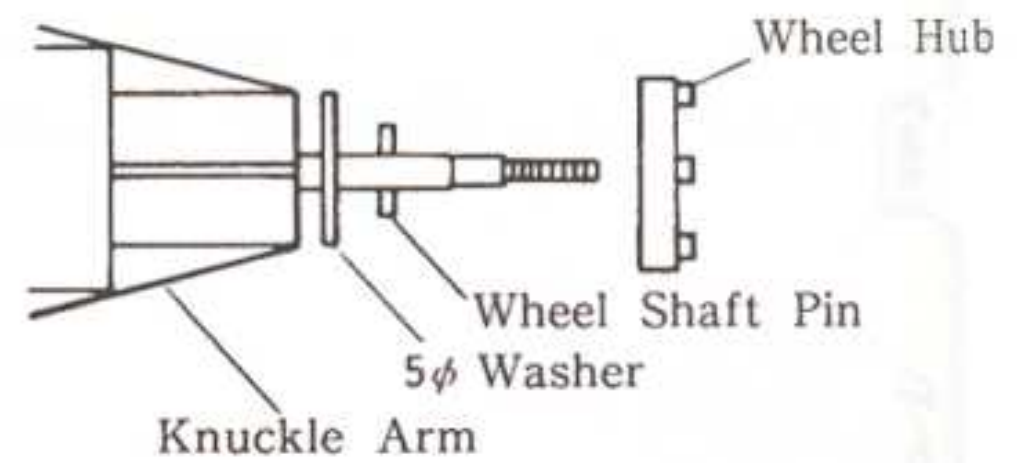
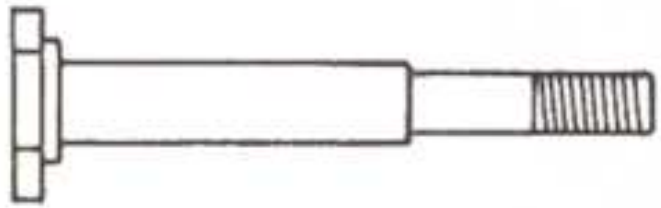

22 PAINTING OF BODY

Cut off the shaded area with scissors or a knife.

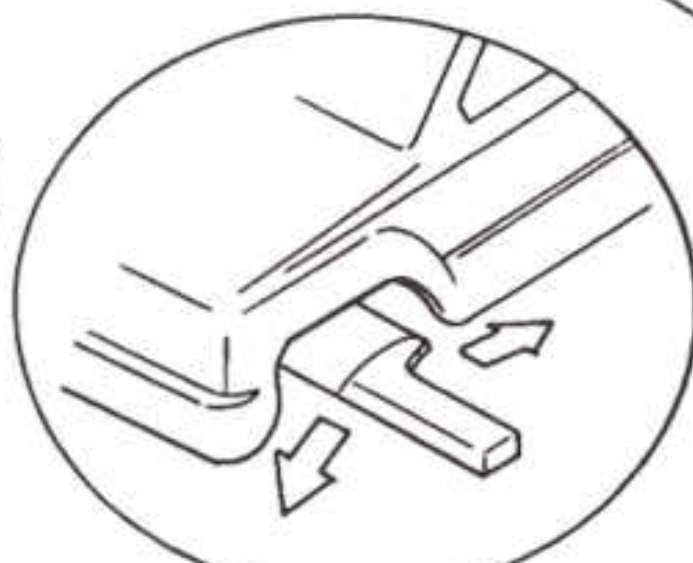
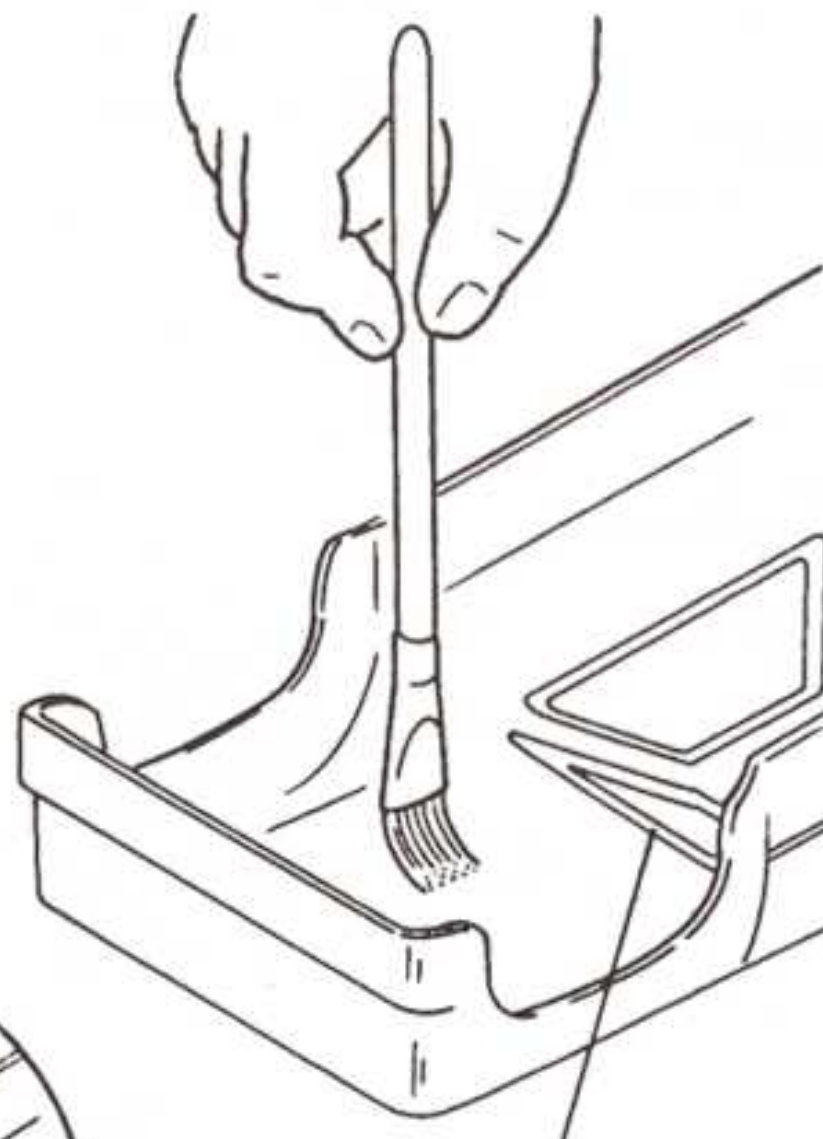
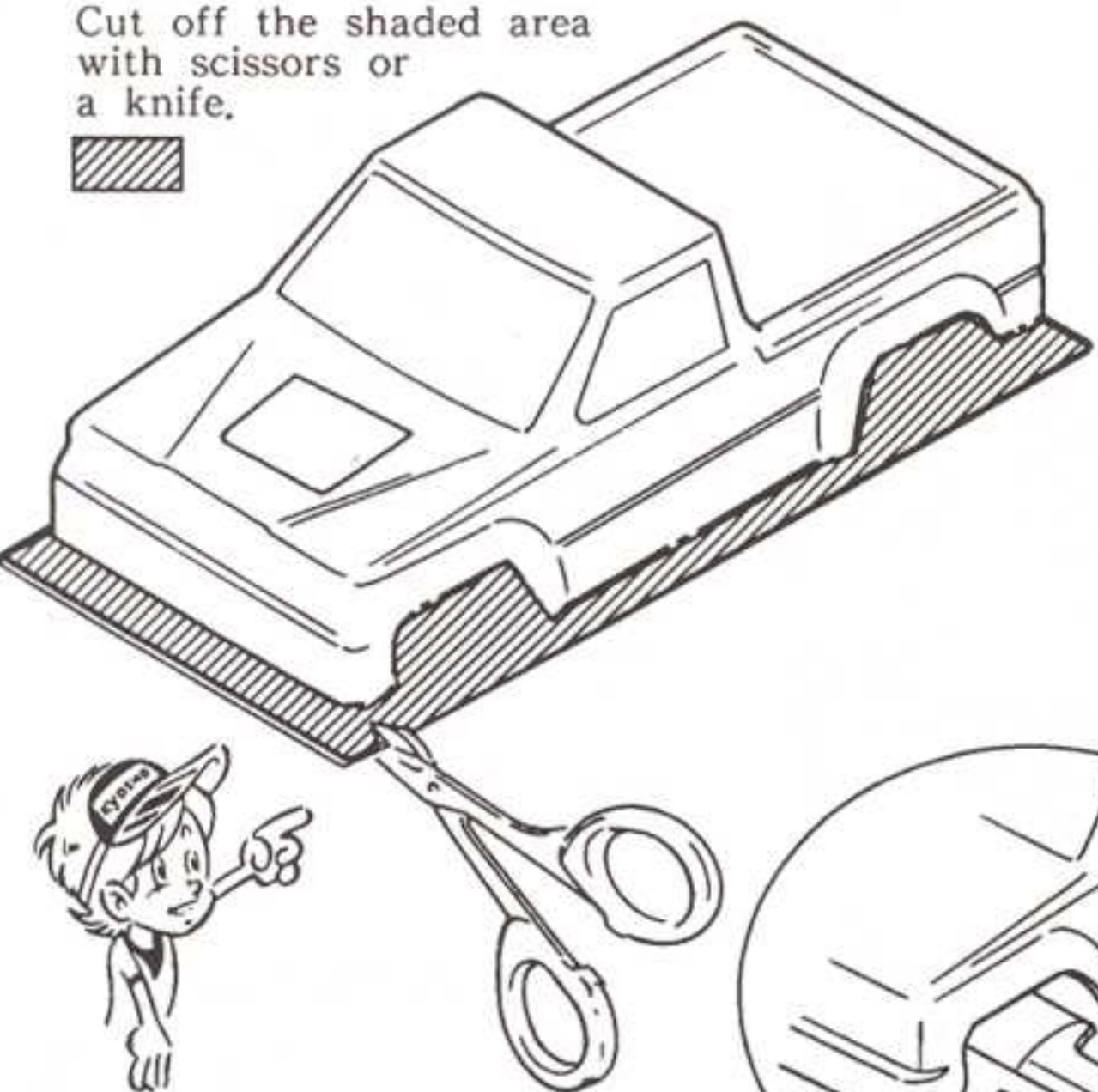

Mask the inside of the body along with the window design with the Micron Tape and paint the inside.

Smooth the cut end with sander.

<Round Cutter & Sander No.1829>



Sander

Use the tips of blade for curved lines.

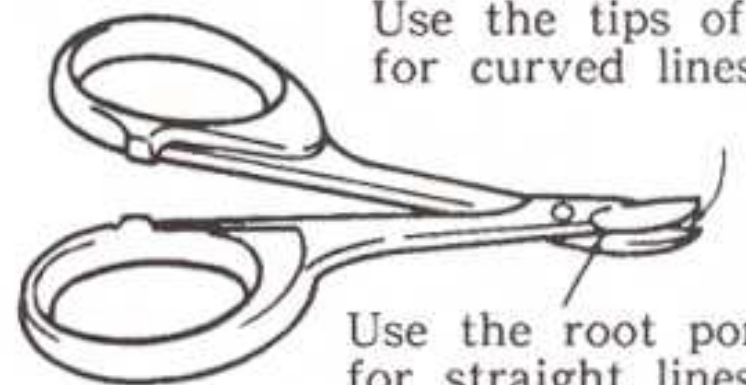

Use the root portion for straight lines.

Micron Line Tape
No.1841... 1mm
No.1842... 1.5mm
No.1843... 2.5mm

Color

White, Red, Yellow
Green, Blue & Black

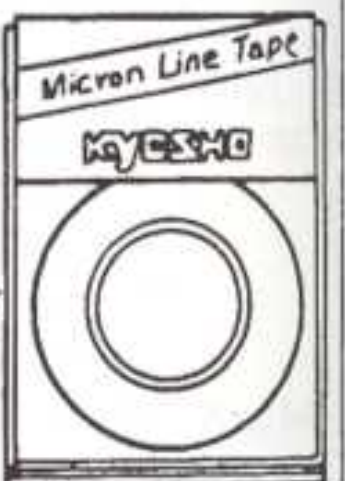

<Polica Color No.2230>

White, Red, Yellow,
Green, Blue, Sky Blue,
Orange, Black, Violet,
F. Pink, Yellow Green,
& F. Orange.



23 INSTALLATION OF ACCESSORY PARTS

Headlight Lenses 2

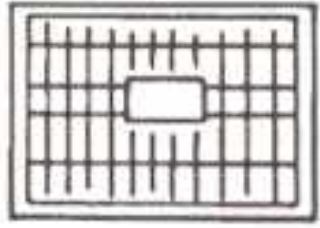

Foglight Lenses 4

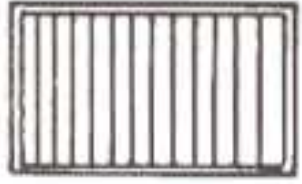

M3x8 TP Screws..... 4

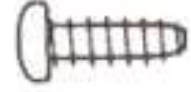

M3 Washers..... 2

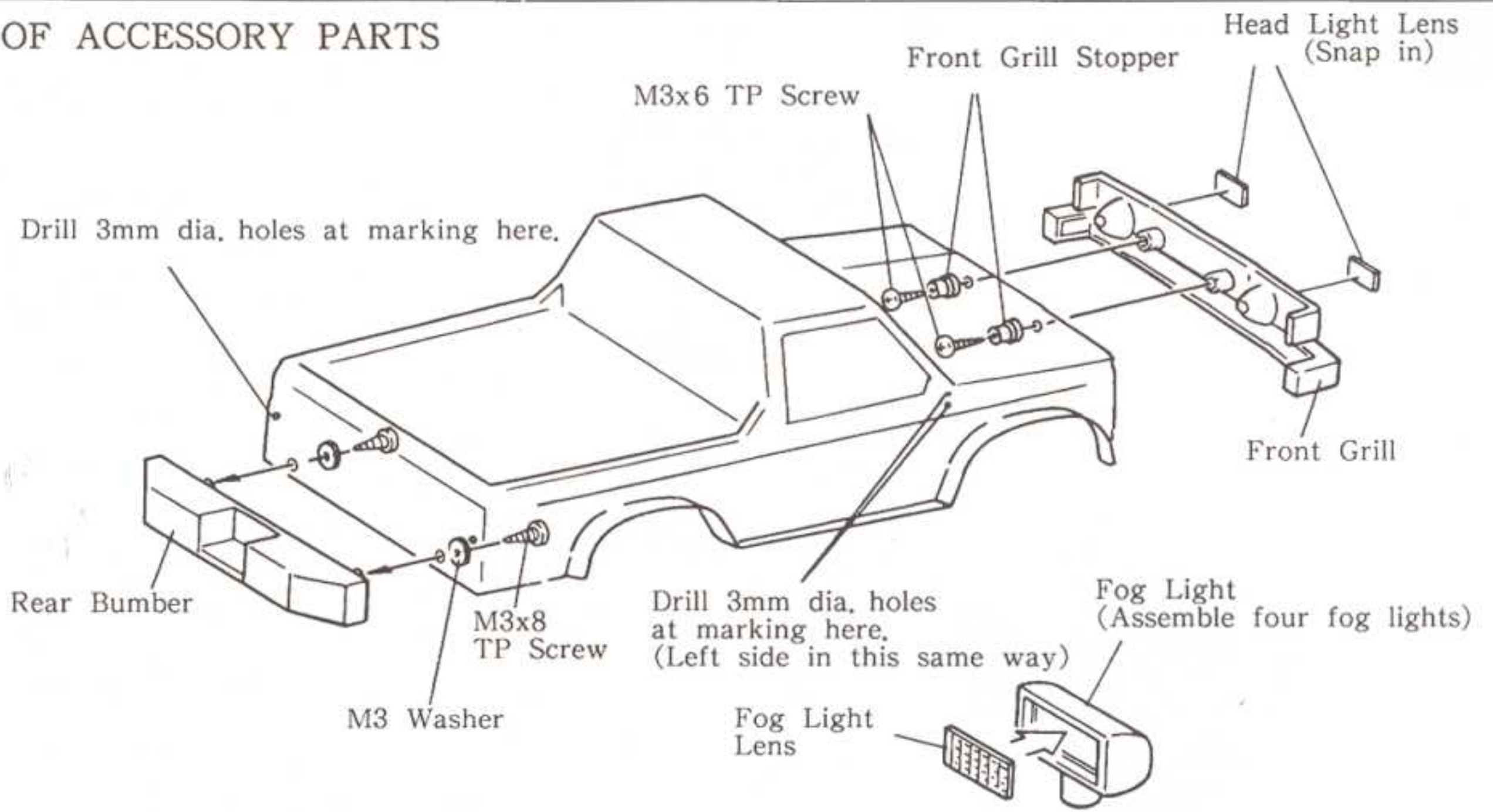

24 INSTALLATION OF ACCESSORY PARTS

M3x8 TP Screws..... 8

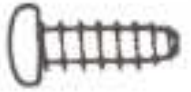

M3 Washers 4



3 φ Stoppers..... 6



Tail Light

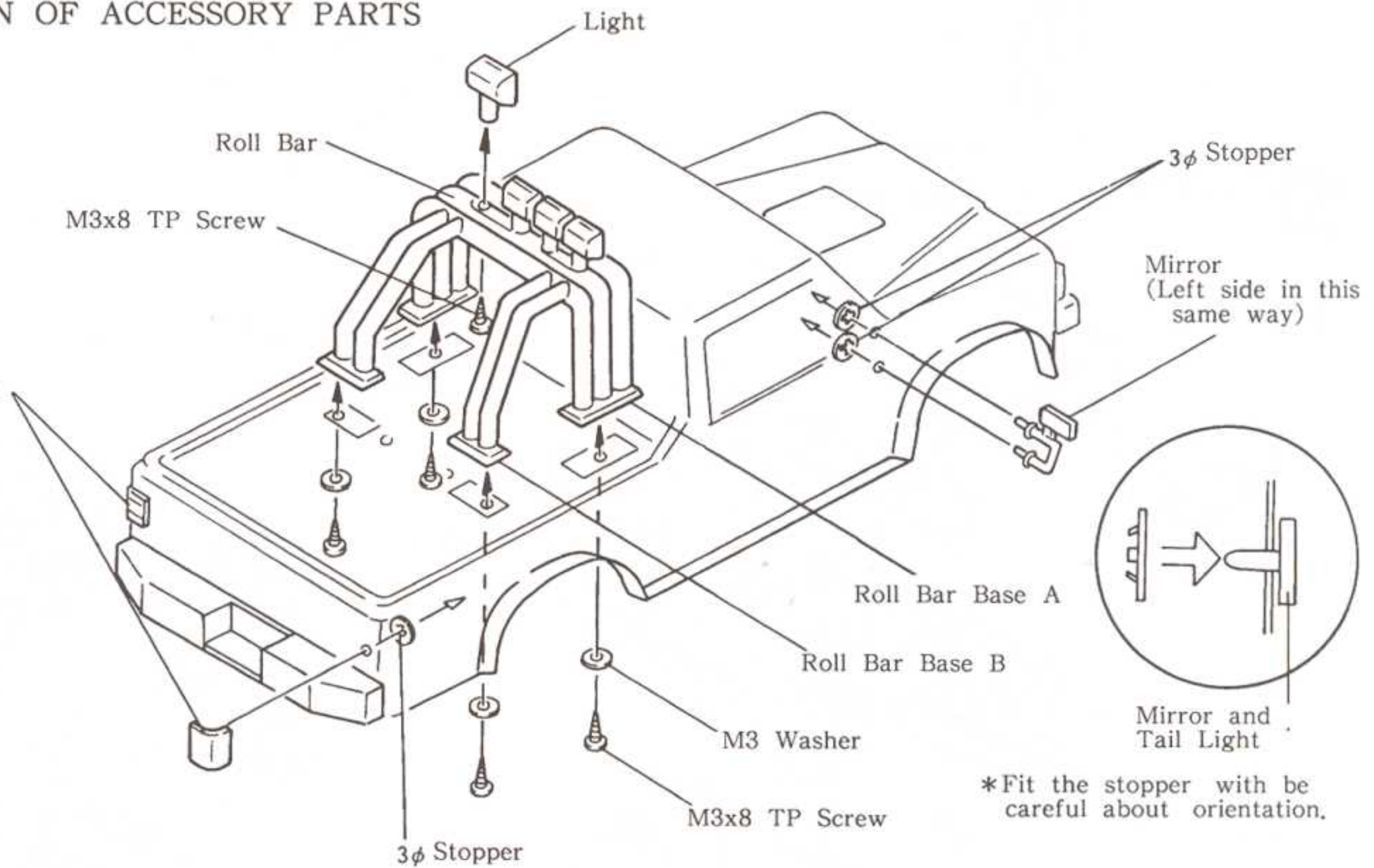

25 INSTALLATION OF BATTERY

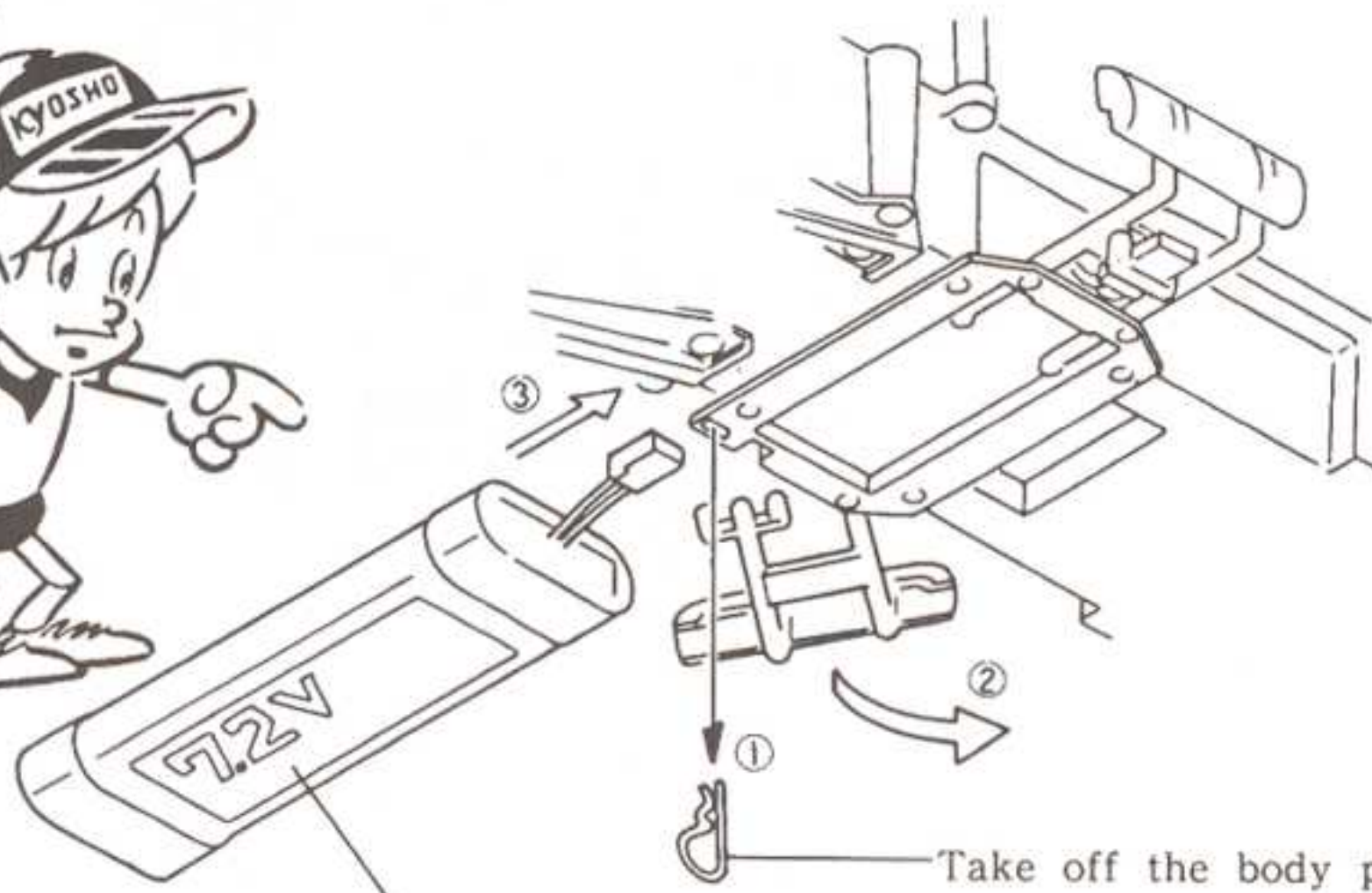

Charged battery in full

Body Pin 1

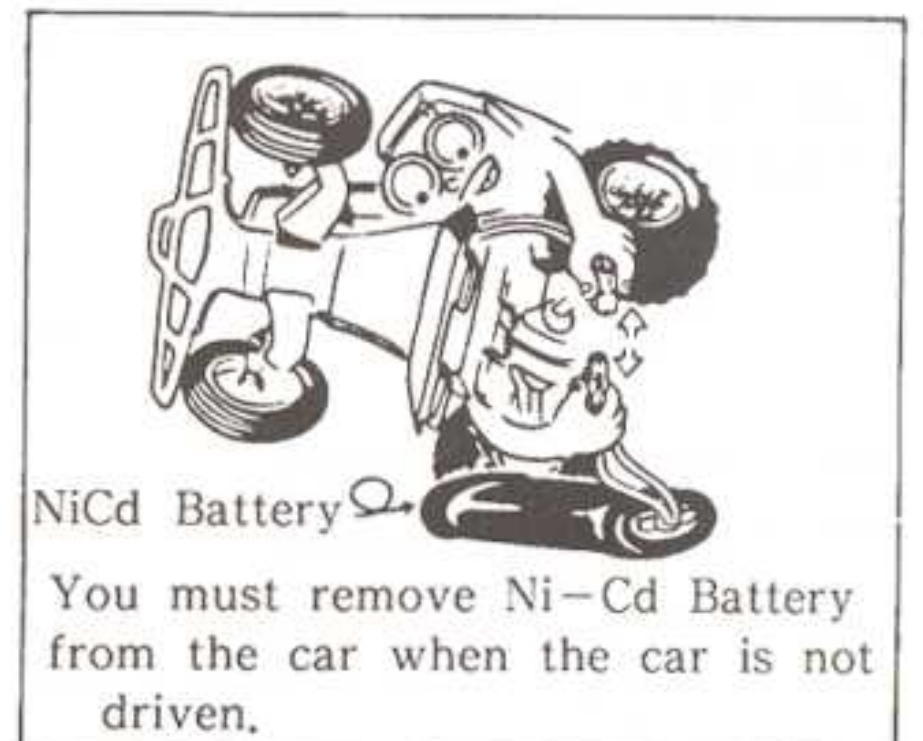
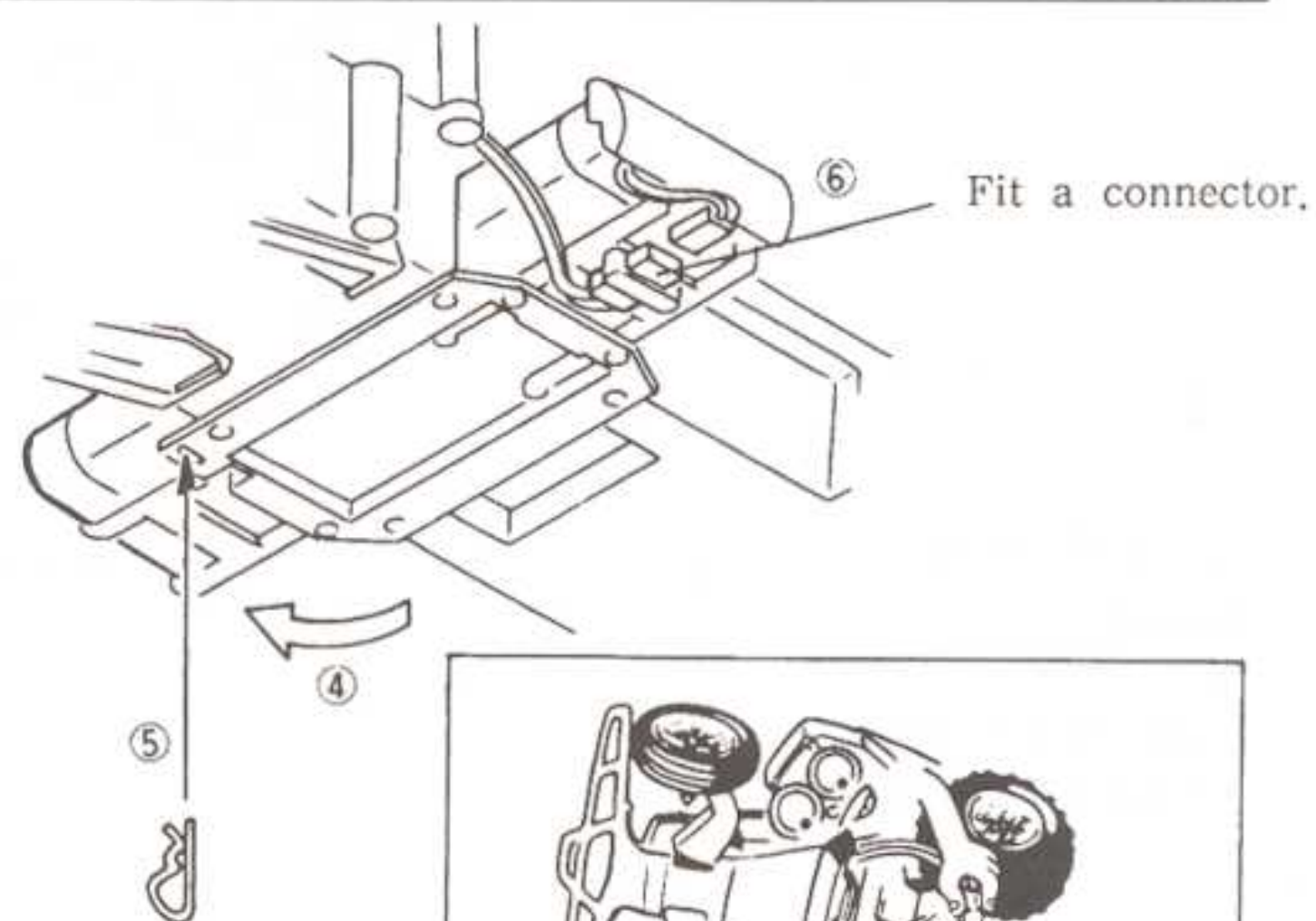

26 INSTALLATION OF BODY

Put on the body and set a body pin into it. (Set all four body pins in this same way.)

Be sure to pin the four hook pins to body mount before mounting the body.

Body Pins 4

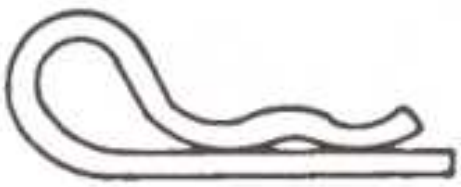

Hook Pins..... 4

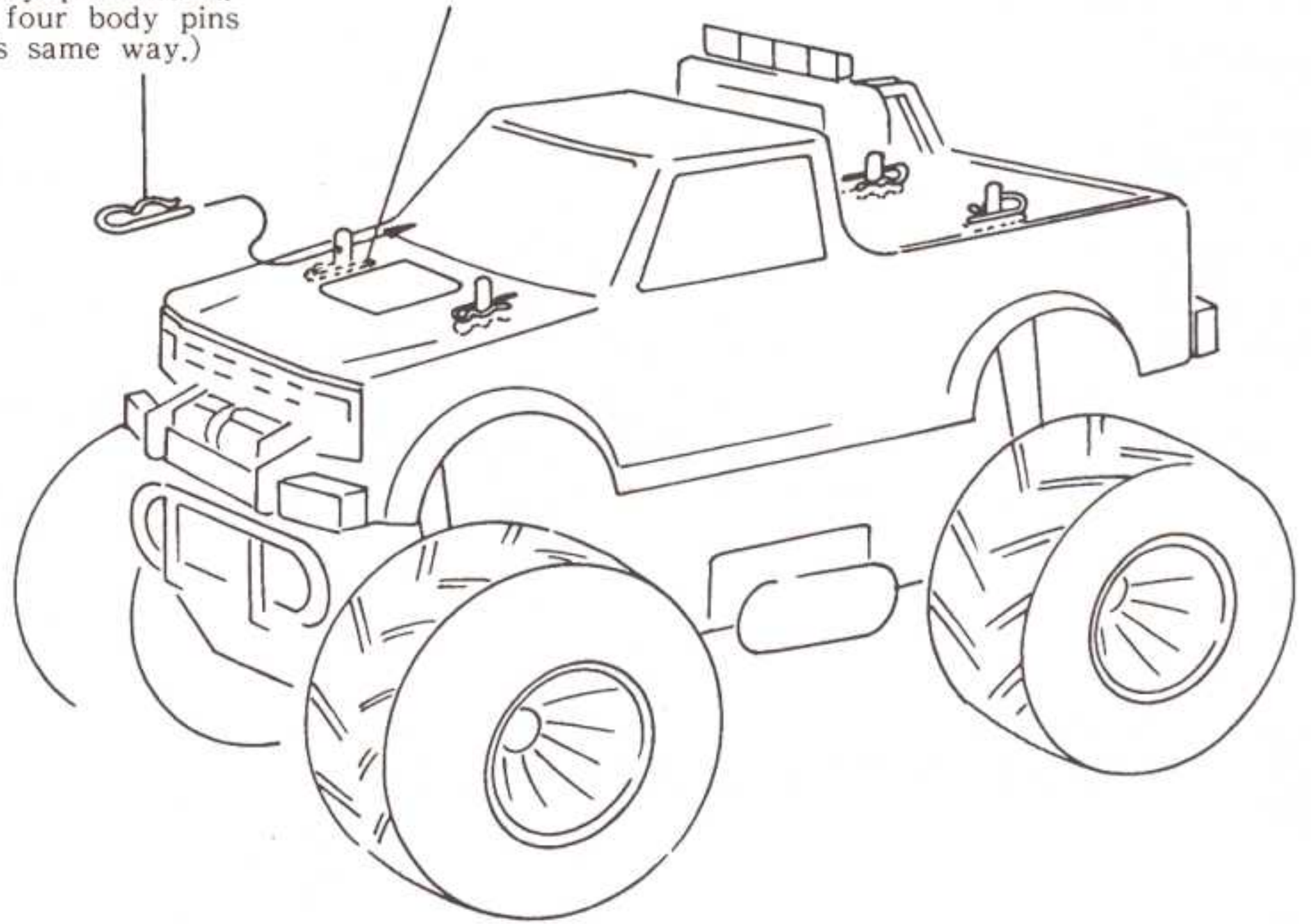

27 ASSEMBLY OF ENGINE

Air Scoop A

Air Scoop B

Engine Head

Exhaust Pipe B

Exhaust Pipe A

Engine Front

Engine Base

M3x8 TP Screw

Double Sided Tape

Body

Put a engine onto front body mount with double sided tape.

Put on the body and set a body pin into it. (Set all four body pins in this same way.)

Be sure to pin the four hook pins to body mount before mounting the body.

M3x8 TP Screws..... 2

Double Sided Tapes ...1

40

BEFORE RUNNING THE CAR

<Adjusting of Speed Controller>

Plug in the connector from the speed controller to the 7.2V Ni-Cd battery and operate your radio. While adjusting, the wheel of car may start to run so keep your model upon a small box to make the wheels aloof from the ground.

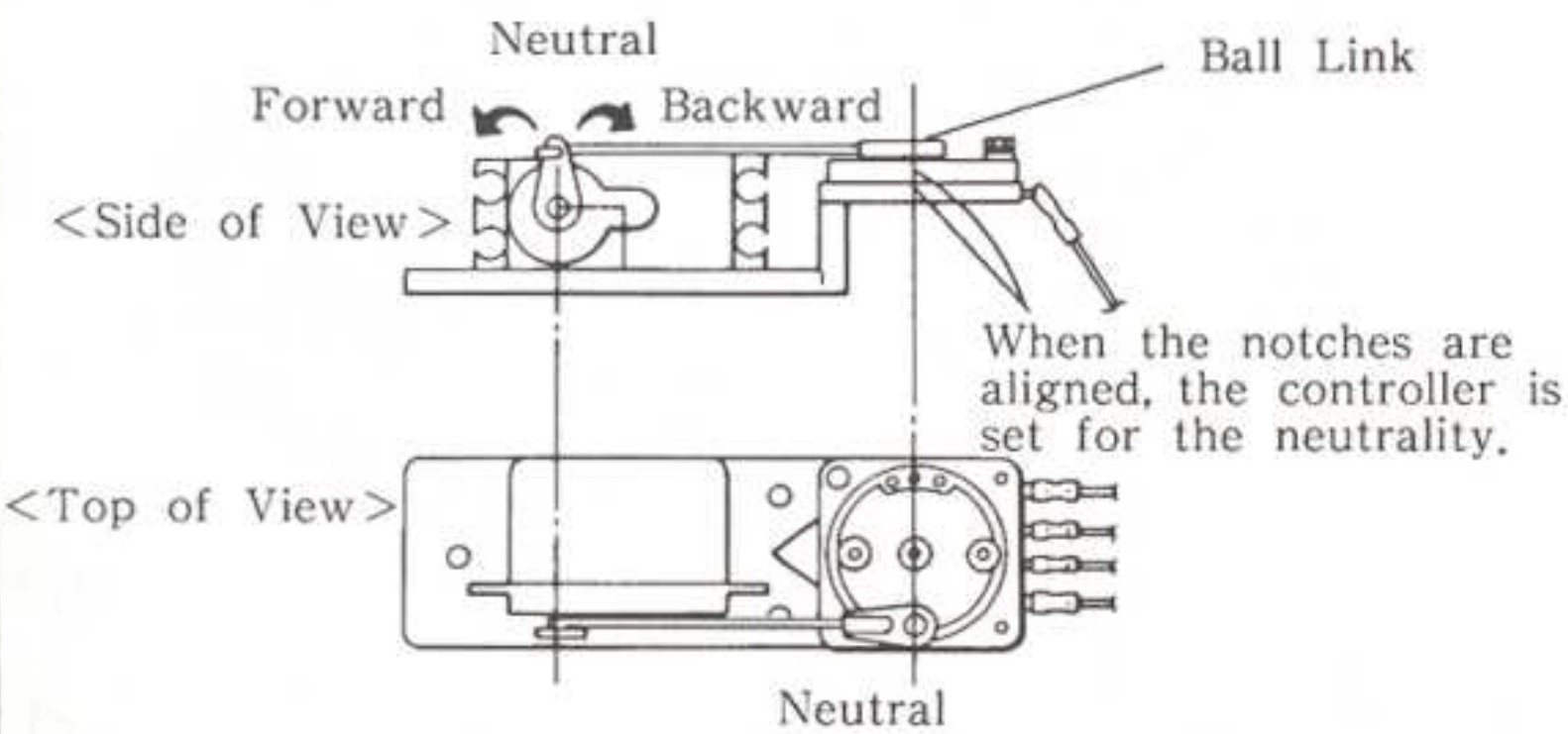

By turning the ball end, adjust the speed controller to the position shown in the drawing above (motor stopped position) with control stick and the trim lever in neutral.

① Adjustment for High Speed

When the control stick on your radio is pushed forward all the way, the controller should be activated and the motor should run at a high speed. By the motor sound, you can tell if the motor is running high, medium, or low speed.

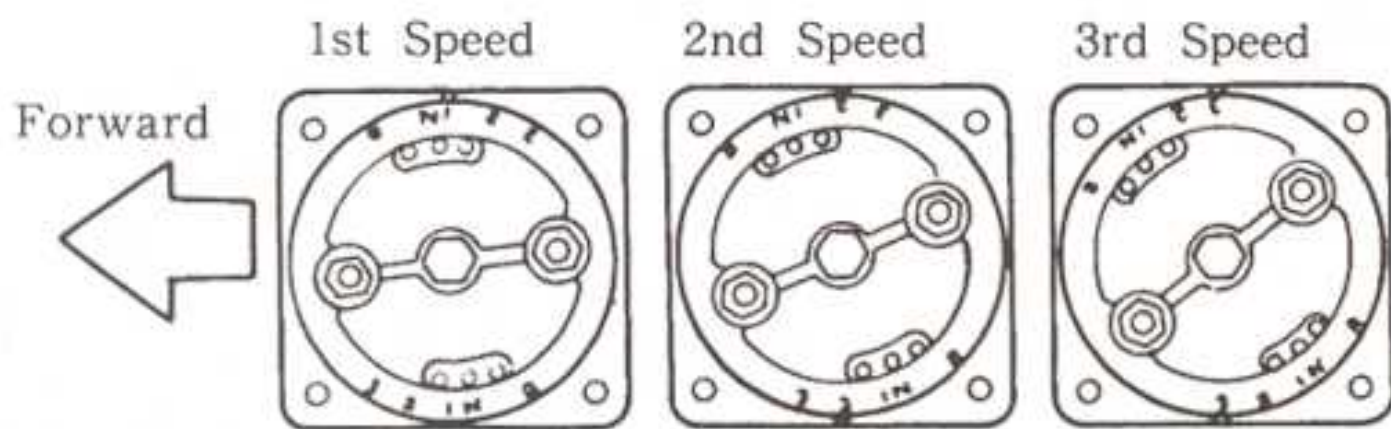

② Adjustment for Reverse

Pull the control stick and the control horn should operate as illustrated in the diagram below. The motor should run in reverse.

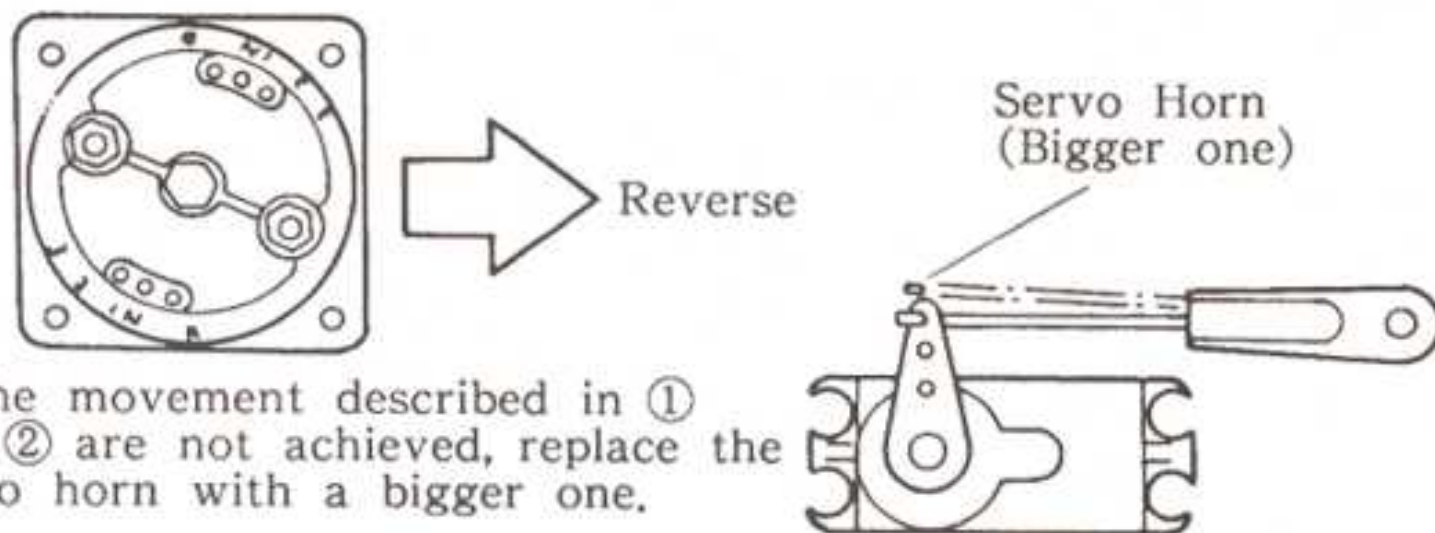

<Adjustment of Toe-In Angle>

This is an important adjustment to drive a car. Set up the front and rear wheels converge slightly toward the front. This toe-in adjustment helps the car go straight and enhance the steering trait.

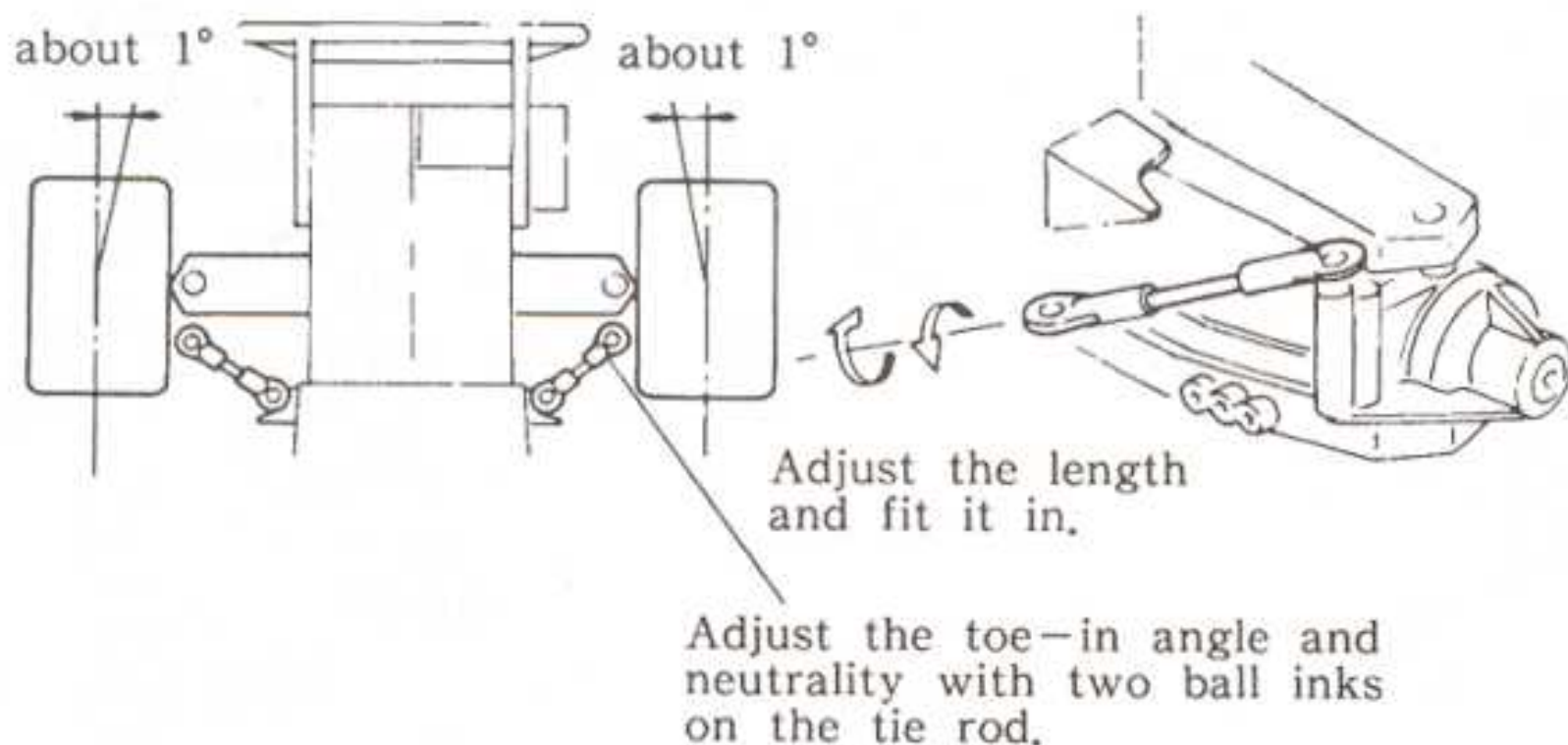

<Checking Speed Controller>

- (1) Check to see if the center nut or the lead fixing nuts are not loosen.
- (2) Check to see if the lead cords do not rub against the rotor or the center nut when the speed controller is in operation, as a result the points on the controller may be out of contact.
- (3) Or the lead may come in contact with the body and causing the same trouble as stated above in (2).
- (4) Check to see if the speed control rod does not rub against a lead fixing nut.

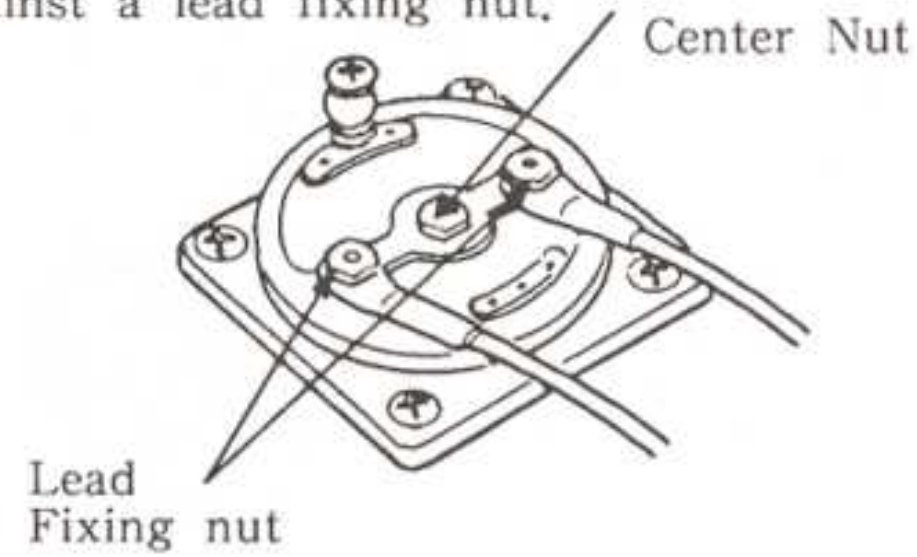

<Up Keep of Speed Controller>

- (1) Remove the center nut from time to time to check to see if anything in the controller. Clean it, if any.
- (2) Make it a rule to check all points from (1) to (4) stated above, before running the car.

*If you notice the motor running intermittently or unsmoothly, examine those four checking points. If you find nothing defective, the controller may be worn out. (In such a case, the surface of the controller plate becomes rough.)

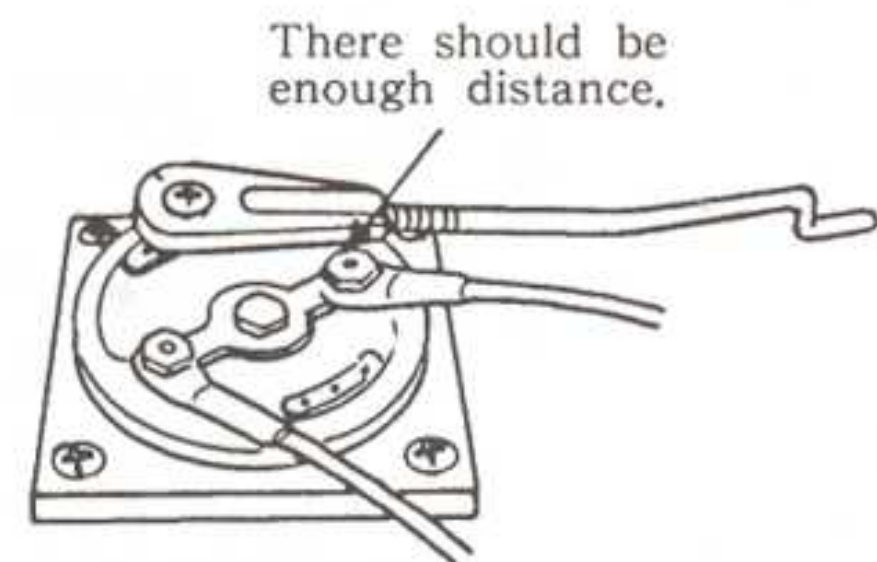
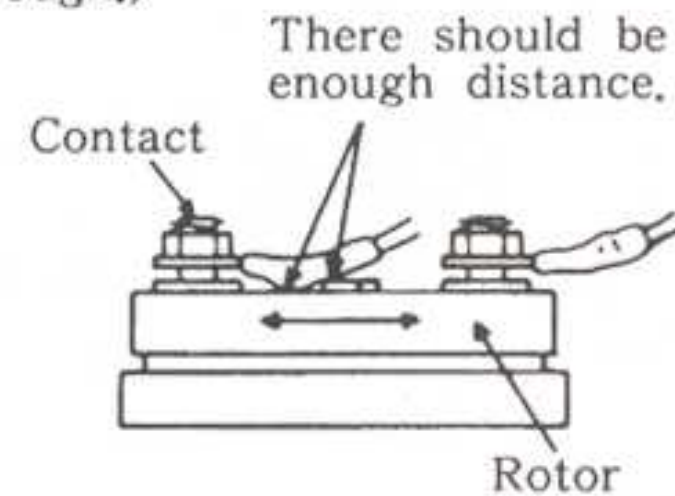

Cautions

If you keep the car running at 1st and 2nd speeds, or backward advancing for more than 20 to 30 seconds, the resistor will generate heat. Try to drive your car at the 3rd speed as much as possible.

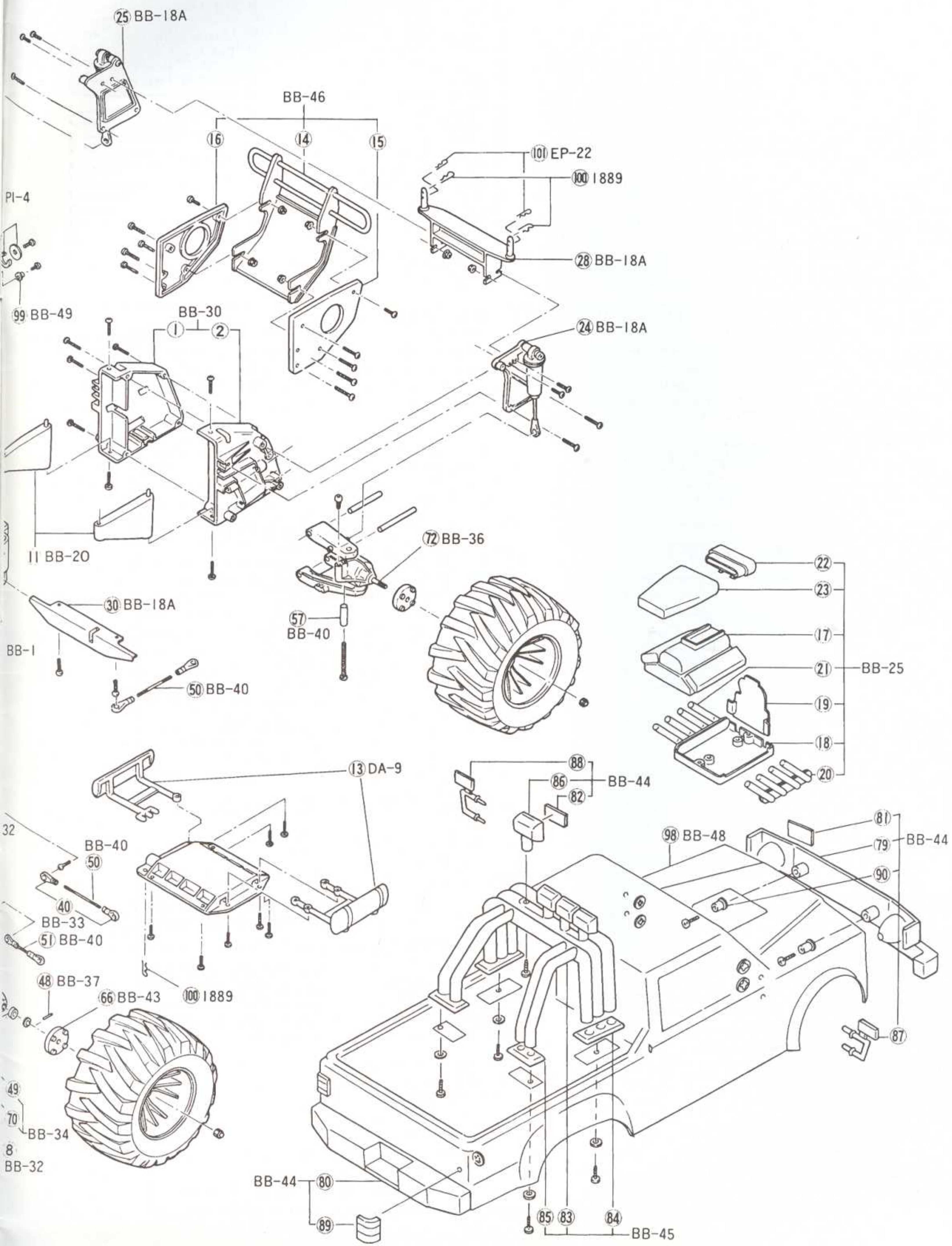

PARTS LIST

Key #	Parts Name	Q'ty	Key #	Parts Name	Q'ty	Key #	Parts Name	Q'ty	Key #	Parts Name	Q'ty
1	Bulk Head A	1	27	Shock Stay RL	1	53	5 φ Plastic Bearing	8	80	Rear Bumber	1
2	Bulk Head B	1	28	Front Body Mount	1	54	Pillow Ball	2	81	Headlight Lens	2
3	Gearbox A	1	29	Rear Body Mount	1	55	4.5 φ Ball Base	1	82	Fog Light Lens	4
4	Gearbox B	1	30	Slider	1	56	4.5 φ Ball Link	1	83	Roll Bar	1
5	Knuckle Arm A	2	31	Gear Cover	1	57	Knuckle Coller	2	84	Roll Bar Base (A)	2
6	Knuckle Arm B	2	32	Diff. Joint	2	58	Speed Control Rod	1	85	Roll Bar Base (B)	2
7	Upper Suspension Arm	4	33	Diff. Side Gear	2	59	Double Sided Tape	1	86	Fog Light	4
8	Lower Suspension Arm	4	34	Idle Gear	1	60	Rubber Pipe	1	87	Mirror (A)	1
9	Main Frame	1	35	Counter Gear	1	61	Motor Cord	1	88	Mirror (B)	1
10	Cover	1	36	Diff. Carrier	1	62	Resistor Cover	1	89	Tail Light	2
11	Block Parts B	1	37	Diff. Bevel Gear	3	63	Resistor Holder Base	1	90	Front Grill Stopper	2
12	Block Parts C	2	38	D Block Parts	1	64	Resistor	1	91	Antenna Pipe	1
13	Block Parts E	1	39	Z Block Parts	1	65	Shock Spring	4	92	Decal	1
14	Front Guard	1	40	5.8 φ Ball Link	16	66	Wheel Hub	4	93	Instruction	1
15	Front Side Gurad R	1	41	Idle Gear Shaft	1	67	Grease	1	94	Tire	4
16	Front Side Guard L	1	42	Idle Gear Shaft Pin	1	68	Vinyl Tie	1	95	Wheel A	4
17	Engine Head	1	43	Counter Gear Shaft	1	69	Nylon Strap	1	96	Wheel B	4
18	Engine Base	1	44	Diff. Joint Shaft	1	70	8 φ Pillow Ball	8	97	Wheel C	4
19	Engine Front	1	45	Suspension Shaft A	6	71	5.8 φ Pillow Ball	16	98	Body	1
20	Exhaust Pipe A	1	46	Suspension Shaft B	2	72	Front Wheel Shaft	2	99	Eyelet	2
21	Exhaust Pipe B	1	47	Shock Shaft	4	73	Rear Wheel Shaft	2	100	Body Pin	5
22	Air Scoop A	1	48	Wheel Shaft Pin	4	74	Pinion Gear (13T)	1	101	Hook Pin	4
23	Air Scoop B	1	49	Ball Seat	8	75	Window	1	102	Cross Wrench	1
24	Shock Stay FR	1	50	M3 Rod A	4	76	Rotary Controller	1			
25	Shock Stay FL	1	51	M3 Rod B	2	77	Le Mans 05 Motor	1			
26	Shock Stay RR	1	52	4 φ Plain Bearing	2	78	Front Grill	1			

PURCHASABLE PARTS FOR YOUR KIT

You can purchase replacement and optional parts for your kit. All of the part identified by key number are usually not available singularly, but we offer these parts in convenient parts "pack" which can be purchased separately. To figure out which parts pack you need, find the key number for that part within the manual.

Then consult out parts pack guide below. When referring to the parts you need, always use the Parts Pack Number. For example, if you need a Idle Gear (Key #35) ask your dealer for Kyosho Parts Pack BB-6 (Gear Set).

No.	Parts Name	Key No. & Q'ty
BB-1	Frame Set	⑨, ⑩ × 1
BB-6	Gear Set	②, ③ × 2, ④, ⑤, ⑥ × 1, ⑦ × 3
BB-14	Rear Wheel Shaft	⑦ × 2
BB-18A	Shock Stay Set (For "Big Boss")	②, ⑤, ⑥, ⑦, ⑧, ⑨, ⑩, ⑪ × 1
BB-20	B Block Parts	⑪ × 1
BB-21	C Block Parts	⑫ × 1
BB-25	Engine Set	⑰, ⑱, ⑲, ⑳, ㉑, ㉒, ㉓ × 1
BB-26	Motor Cord	⑥ × 1
BB-30	Bulk Head	①, ② × 1
BB-31	Knuckle Arm	⑤, ⑥ × 1
BB-32	Suspension Arm	⑦, ⑧ × 1
BB-33	5.8φ Ball Link	⑩ × 12
BB-34	8φ Pillow Ball Set	④, ⑩ × 4
BB-35	5φ Plastic Bearing	⑤ × 8
BB-36	Front Wheel Shaft	⑫ × 2
BB-37	Shaft, Pin	⑬ × 10
BB-38	Suspension Shaft	⑭ × 6, ⑮ × 2
BB-39	Gear Shaft Set	⑰, ⑱, ⑲, ⑳ × 1, ㉑ × 2
BB-40	Rod Set	⑤ × 4, ⑥, ⑦, ⑧ × 2
BB-41	Shock Shaft Set	⑫, ⑬ × 4
BB-42	Small Parts Set	⑭, ⑮, ⑯, ⑰, ⑱, ⑲, ⑳, ㉑, ㉒, ㉓ × 1
BB-43	Wheel Hub	⑳ × 4
BB-44	Accessory Set	㉔, ㉕, ㉖, ㉗ × 1, ㉘, ㉙, ㉚ × 2, ㉛, ㉜ × 4
BB-45	Roll Bar Set	㉝ × 1, ㉞, ㉟ × 2
BB-46	Front Guard	㊱, ㊲, ㊳ × 1
BB-47	Decal (For Big Boss)	㊴ × 1
BB-48	Body (For Big Boss)	㊵ × 1
BB-49	Screw Set (For Big Boss)	㊶, ㊷ Screw, Nut, Wrench etc.

No.	Parts Name	Key No. & Q'ty
DA-1	Gear Box	③, ④ × 1
DA-9	E Block Parts	⑬ × 1
DA-13	Spike Tire Set	⑲ × 2
DA-14	Wheel Set	⑳, ㉑, ㉒, ㉓ × 2
OT-31	M3 Pillow Ball	⑰ × 10
OT-50	Pinion Gear (13T)	⑳ × 1
PI-4	DZ Block (P-11)	⑳, ㉑ × 1
EP-22	Hook Pin	⑩ × 5
1815	Rotary Controller	⑤, ⑥, ⑦ × 1
1819	15W Resistor Set	②, ③, ④ × 1
1889	Body Pin	⑩ × 5
Optional Parts		
1903	Ball Bearing (4 φ X 8 φ)	2pcs.(Instead of D-3 & 4 φ Plain Bearing)
1901	Ball Bearing (5 φ X 10 φ)	2pcs.(Instead of 5 φ Plastic Bearing)
PI-15	Ball Bearing (8 φ X 10 φ)	2pcs.(Instead of D-4)
W-5002	Pressure Shock (L)	Constant Volume Type Shock x 2 set
W-5004	Adjustable Oil Shock	2 set
1951	Shock Oil (S,M,L.)	For Oil Shock
OT38	Silicone Grease	For Gear & Plain Bearing
1883	Frontier Hobby Oil	For Gear & Plain Bearing
SC40	Motor Cover	Protect from dirt
1863	Sponser Sticker	
1856	Fog Light Set	Light (4), Case, Battery Case
NB-13	Light Set	W/Light (2), Battery Case

The following option parts are required to make "Big Boss" perfect with ball bearings.

- 1903 Ball Bearing.....2 sets
- 1901 Ball Bearing4 sets
- PI-15 Ball Bearing.....1 set



This products is not to be sold in the United States. If you have purchased this product in the United States, please contact Tom Miller at Kyosho U.S.A. phone number (217) 398-3630