

# OWNER'S MANUAL

# TEAM XX4 LOSI



- ⑦ Carefully read through all instructions to familiarize yourself with the parts, construction, tuning tips, and techniques outlined in this manual. Being able to grasp the overall design of your XX-4 4WD off-road car before construction will ensure a smooth assembly.
- ⑦ Take your time and pay close attention to detail. Keep this manual for future reference.

# TEAM LOSI

*Racing*

TEAM LOSI, INC., CHINO, CA 91710 P/N 800-0087  
MADE IN THE UNITED STATES OF AMERICA

# WELCOME XX-4 OWNER!

Thank you for selecting Team Losi and the XX-4 as your new off-road racing vehicle. As you will soon see, we have made every effort to produce a kit that is not only the most competitive, but easy to build and maintain as well. The simple bag-by-bag assembly sequence and unmatched easy-to-follow instructions, combined with Team Losi's famous quality-fitting parts, should make building your XX-4 an enjoyable project.

Before you open a bag or start any assembly, please take a few moments to read completely through the following instructions. This will familiarize yourself with not only the various parts, but the tools you will need as well.

Once again, thank you for choosing Team Losi.

Good luck and good racing!

## 1. INTRODUCTION

### XX-4 COMPLETED KIT DIMENSIONS

Overall Length: 15-1/2"  
Wheelbase: 10-3/4"

Front Width: 9-5/8"  
All dimensions at ride height.

Rear Width: 9-7/8"  
Weight will vary depending on accessories.

Height: 5.75"


### NOTES & SYMBOLS USED


#### Figure 1


This is a common figure number found at the beginning of each new illustration throughout the manual.

Step 1. - Each step throughout the entire manual has a check box to the left of it. As you complete each step, mark the box with a check. If you need to take a break and return to building at a later time you will be able to locate the exact step where you left off.

**\*NOTE:** This is a common note. It is used to call attention to specific details of a certain step in the assembly.

 **IMPORTANT NOTE:** Even if you are familiar with Team Losi kits, be sure and pay attention to these notes. They point out very important details during the assembly process. Do not ignore these notes!

 This wrench designates a performance tip. These tips are not necessary, but can improve the performance of your XX-4 car.

 In illustrations where it is important to note which direction parts are pointing, a helmet like this one will be included in the illustration. The helmet will always face the front of the car. Any reference to the right or left side will relate to the direction of the helmet.

### KIT/MANUAL ORGANIZATION

The XX-4 is composed of different bags marked A through H. Each bag contains all of the parts necessary to complete a particular section of the XX-4 car. Some of these bags have subassembly bags within them. It is essential that you open only one bag at a

time and follow the correct assembly sequence, otherwise you may face difficulties in finding the correct part. It is helpful to read through the instructions for an entire bag prior to beginning assembly. Key numbers (in parenthesis) have been assigned to each part and remain the same throughout the manual. In some illustrations, parts which have already been installed are not shown so that the current steps can be illustrated more clearly.

For your convenience, an actual size hardware identification guide is included with each step. To check a part, hold it against the silhouette until the correct part is identified. In some cases extra hardware has been supplied for parts that may be easy to lose.

The molded parts in the XX-4 are manufactured to demanding tolerances. When screws are tightened to the point of being snug, the parts are held firmly in place. For this reason it is very important that screws not be overtightened in any of the plastic parts.

To insure that parts are not lost during construction, it is recommended that you work over a towel or mat to prevent parts from rolling away.

### IMPORTANT SAFETY NOTES

1. Select an area for assembly that is away from the reach of small children. *The parts in the kit are small and can be swallowed by children, causing choking and possible internal injury.*

2. The shock fluid and greases supplied should be kept out of children's reach. *They are not intended for human consumption!*

3. *Exercise care* when using any hand tools, sharp instruments, or power tools during construction.

4. *Carefully read all manufacturer's warnings and cautions* for any glues, chemicals, or paints that may be used for assembly and operating purposes.

## TOOLS REQUIRED

Team Losi has supplied all necessary Allen wrenches and a special wrench that is needed for assembly and adjustments. The following common tools will also be required: Needle-nose pliers, regular pliers, hobby knife, scissors or other body cutting/trimming tools, and a soldering iron may be necessary for radio installation. 3/16", 1/4", and 3/8" nut drivers are optional.

## RADIO/ELECTRICAL

A suggested radio layout is provided in this manual. Your high-performance R/C center should be consulted regarding specifics on radio/electrical equipment.

## HARDWARE IDENTIFICATION

When in question, use the hardware identification guide in each step. For screws, the prefix number designates the screw size and number of threads per inch (i.e. 4-40 is #4 screw with 40 threads per inch). The second number or fraction designates the length of the screw. For cap-head screws, this number refers to the length of the threaded portion of the screw. For flat-head screws, this number refers to the overall length of the screw. Bearings and bushings are referenced by the inside diameter x outside diameter. Shafts and pins are diameter x length. Washers are described by inside diameter or the screw size that will pass through the inside diameter. E-clips are sized by the shaft diameter that they attach to.

## MOTORS AND GEARING

The XX-4 includes an 84-tooth, 48-pitch spur gear. The overall internal drive ratio of the XX-4 is 2.3:1. The pinion gear that is used will determine the final drive ratio. To calculate the final drive ratio, first divide the spur gear size by the pinion gear size. For example, if you are using a 20-tooth pinion gear, you would divide 84 (spur gear size) by 20 (pinion gear size).  $84/20 = 4.2$ . This tells you that 4.2 is the external drive ratio. Next, multiply the internal drive ratio (2.3) by the external drive ratio (in this case 4.2).  $2.3 \times 4.2 = 9.66$ . This means that by using a 20-tooth pinion gear with the standard 84-tooth spur gear, the final drive ratio is 9.66:1.

Consult your high-performance shop for recommendations to suit your racing style and class. The chart below lists some of the more common motor types and a recommended initial gearing for that motor. Ratios can be adjusted depending on various track layouts, tire sizes, and battery types.

### RECOMMENDED INITIAL GEARING FOR COMMON MOTORS

TYPE OF MOTOR	PINION	SPUR
24° Stock	??	84
36° Stock	??	84
10-Turn Modified	18	84
11-Turn Modified	19	84
12-Turn Modified	20	84
13-Turn Modified	21-22	84
14-Turn Modified	22-23	84
15-Turn Modified	24	84
16-Turn Modified	25	84

## TABLE OF CONTENTS

1. INTRODUCTION .....	i	3. BAG B .....	5-10
Completed Kit Dimensions .....	i	4. BAG C .....	11-18
Notes & Symbols .....	i	5. BAG D .....	19-24
Kit Manual Organization .....	i	6. BAG E .....	25-29
Important Safety Notes .....	i	7. BAG F .....	30-33
Tools Required .....	ii	8. BAG G .....	34
Radio/Electrical .....	ii	9. BAG H .....	35-40
Hardware Identification .....	ii	10. Tips from the Team .....	41-43
Recommended Gearing .....	ii	11. Spare Parts .....	44-47
2. BAG A .....	1-4	12. Glossary .....	47

*Team Losi is continually changing and improving designs; therefore, the actual part may appear slightly different than the illustrated part. Illustrations of parts and assemblies may be slightly distorted to enhance pertinent details.*

# BAG A

**Figure 1**



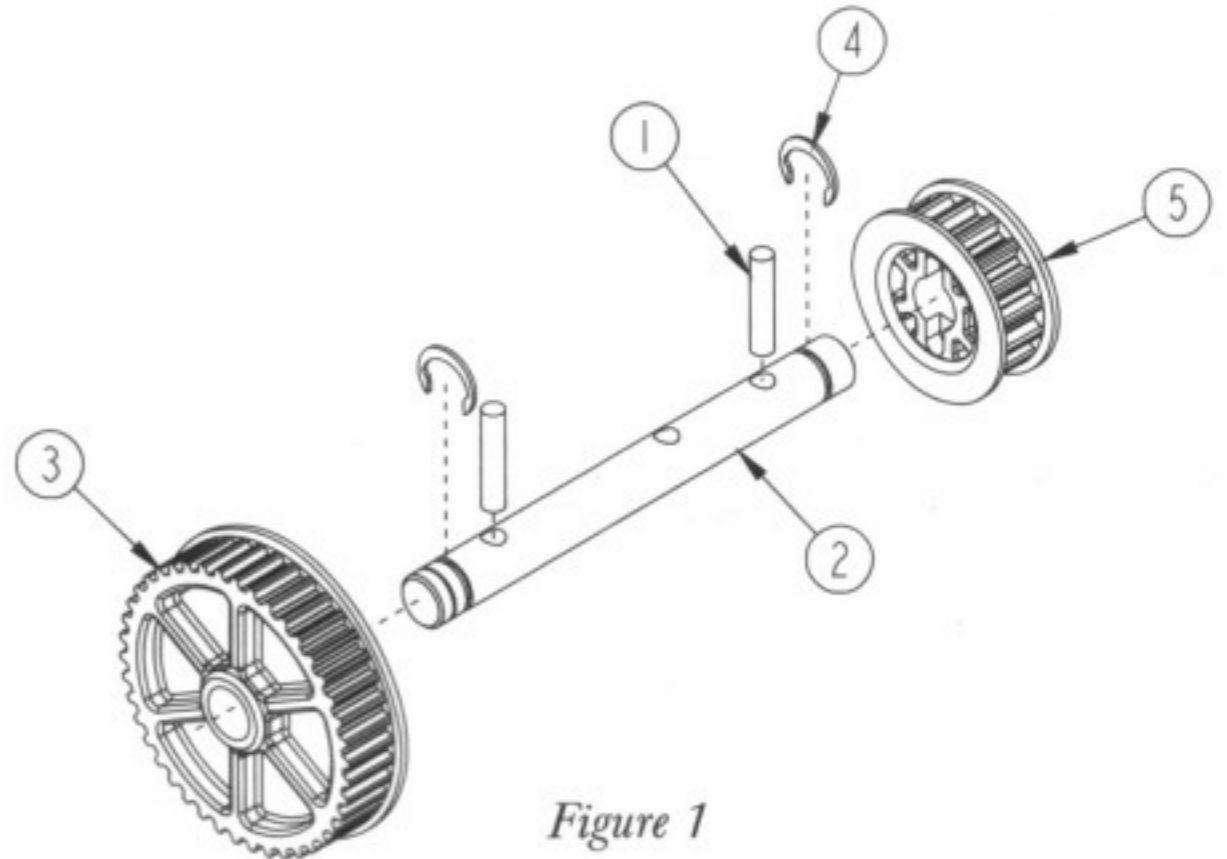
❑ Step 1. Press a .078" x 3/8" spirol pin (1) into the outer hole in each end of the layshaft (2). Center the pins (1) in the shaft (2) so that they extend evenly from both sides of the shaft (2).

*\*NOTE: The .078" x 3/8" pins are the two long spirol pins found in bag A. There is also a shorter spirol pin which will be used in step 4. The layshaft has three holes in it and no threads on the end.*

❑ Step 2. Place the large (42 tooth) 2mm belt pulley (3) over the end of the layshaft (2) with two grooves. Align the pin (1) with the slot in the pulley (3) and press the pulley (3) over the pin (1). Secure the pulley (3) to the layshaft (2) with a 3/16" C-clip (4).

**! IMPORTANT NOTE:** The C-clip must be attached to the layshaft in the wider of the two grooves. This is the groove farthest away from the end of the shaft.

❑ Step 3. Attach the small (17 tooth) 3mm belt pulley (5) to the open end of the layshaft (2). Align the pin (1) with the slot in the pulley (5) and press the pulley (5) over the pin (1). Secure the pulley (5) to the layshaft (2) with a 3/16" C-clip (4).



*Figure 1*

**Figure 2**

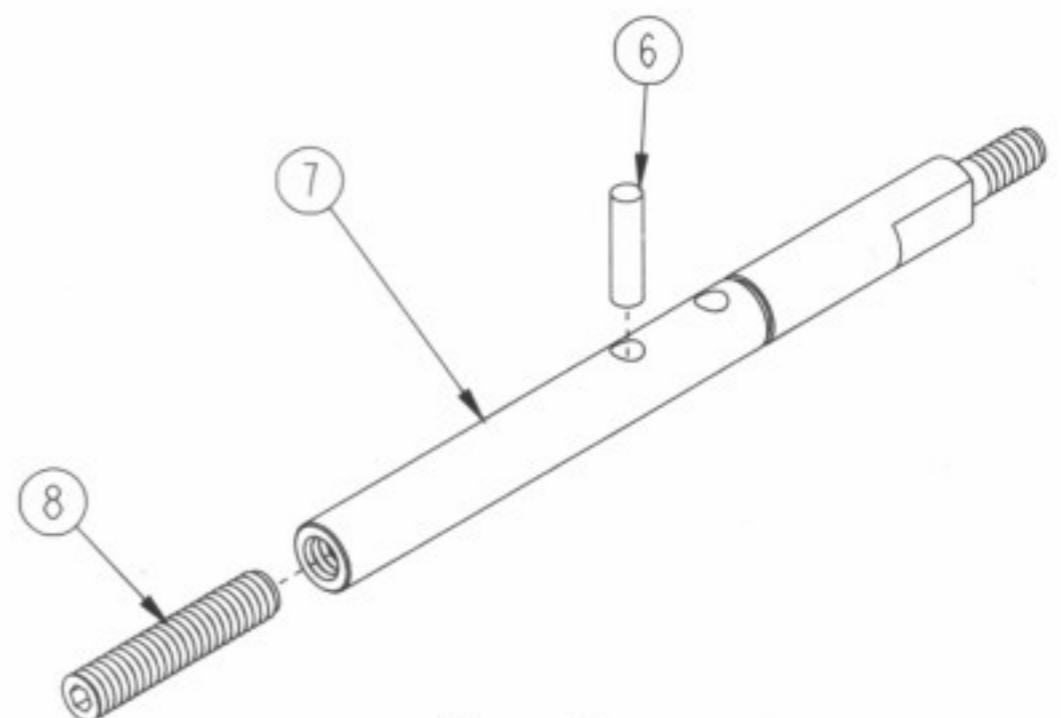


❑ Step 4. Press the .078" x 5/16" spirol pin (6) into the hole farthest from the groove in the slipper shaft (7). Center the pin (6) in the shaft (7) so that the pin (6) extends evenly from both sides of the shaft (7).

❑ Step 5. Thread the 5-40 x 5/8" set screw (8) all the way into the end of the slipper shaft (7). This is easiest accomplished by inserting the 1/16" Allen wrench (9) into the open hole in the shaft (7) to hold it in place while tightening the set screw (8).

**! IMPORTANT NOTE:** The pin must be centered in the slipper shaft.

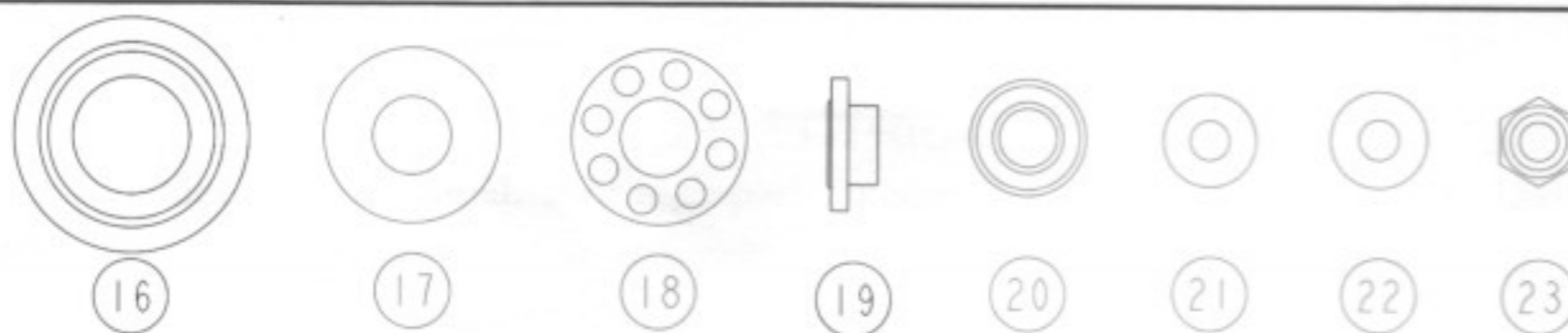
🔑 A small amount of liquid thread-lock will hold the set screw securely in place.



*Figure 2*

# BAG A (Continued)

Figure 3



❑ Step 6. Slide the front slipper back plate (10) over the end of the slipper shaft (7) with no flat spots. While aligning the pin (6) in the shaft (7) with the slot in the back plate (10), press the back plate (10) all the way against the pin (6).

❑ Step 7. Place the front (yellow) slipper pad (11) on the side of the spur gear (12) and align the notches on the spur gear (12) with the notches in the slipper pad (11).

❑ Step 8. Place the spur gear/slipper pad assembly, pad side first, on the slipper shaft (7). Slide the assembly all the way across the shaft, against the back plate (10). Ensure that the slipper pad (11) and spur gear (12) are still properly aligned.

❑ Step 9. Position the rear (dark-colored) slipper pad (13) over the slipper shaft (7) against the exposed side of the spur gear (12). Be certain that the notches in the slipper pad (13) align with the notches on the spur gear (12).

❑ Step 10. Align the three posts on the 29-tooth 2mm belt pulley (14) with the three holes in the rear slipper back plate (15). Press the pulley (14) flush against the back plate (15). Slide the pulley/back plate assembly, back plate (15) first, over the slipper shaft (7) and against the rear slipper pad (13).

🔑 If there is any flashing (three small points) present on the outside surface of the pulley, it should be cut off before continuing. Flashing is rarely present, but if it exists it could make alignment of parts in the upcoming steps more difficult.

❑ Step 11. Place the pulley flange (16) next to the pulley (14) and center it over the shoulder on the pulley (14). The side of the flange (16) with the ring cut in it should face away from the pulley (14).

❑ Step 12. Position one of the two slipper thrust washers (17) next to the pulley flange (16). Center the thrust washer so that it sits over the shoulder on the pulley (14). Slide the slipper thrust bearing (18) over the slipper shaft (7), next to the thrust washer (17), followed by the second thrust washer (17).

❑ Step 13. Slide the thrust bearing spacer (19), small flange side first, down the shaft (7) next to the outer thrust washer (17). The small flange on the spacer (19) should fit into the center of the outer washer (17) and the thrust bearing (18) so that the large portion of the spacer (19) rests flush against the outer washer (17).

❑ Step 14. Place a 3/16" x 3/8" bearing (20) next to the thrust bearing spacer (19). Slide the small plastic bearing washer (21) over the set screw (8) in the shaft (7) so that it rests against the bearing (20).

*\*NOTE: If the 3/16" x 3/8" bearing only has one Teflon™ seal (tan, woven looking) in it, position the seal to the outside – away from the spur gear.*

❑ Step 15. Stack the four 1/8" Belleville washers (22) in opposing directions as shown in Figure 3A so that the small side of the first washer (22) rests against the bearing washer (21). The small side of the fourth washer (22) should face the outside of the assembly.

❑ Step 16. Thread the 5-40 locknut (23) onto the set screw (8) by hand. Insert the 1/16" Allen wrench (9) into the open hole in the shaft (7). Tighten the nut (23) until it just touches the outside Belleville washer (22). From this point, tighten the nut (23) one full turn (360°). This should be a good starting point for the slipper adjustment.

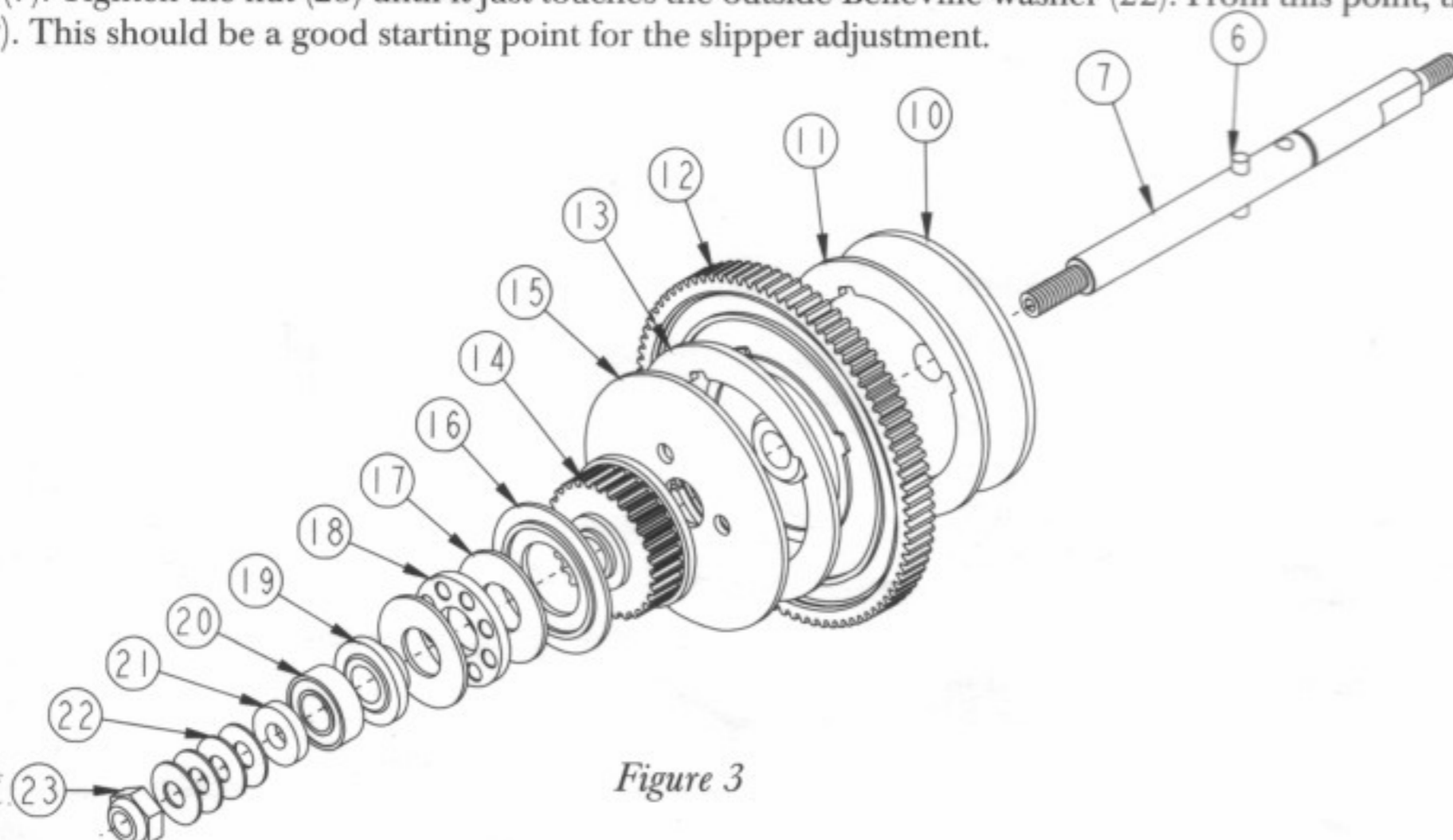


Figure 3



Figure 3A

# BAG A (Continued)

## Figure 4

❑ Step 17. Snap a 3/16" C-clip (4) into the groove in the center of the slipper shaft (7).

❑ Step 18. Place a 3/16" x 3/8" bearing (20) over the shaft (7), next to the C-clip (4).

*\*NOTE: If the 3/16" x 3/8" bearing only has one Teflon™ seal (tan, woven looking) in it, position the seal to the outside – away from the center of the shaft.*

❑ Step 19. Slide the one-way/clicker pulley flange (175) over the shaft (7) so that the small shoulder rests against the bearing (20). Place the one-way/clicker pulley (24) over the shaft (7), next to the flange (175) so that the splines on the pulley (24) are to the outside.

❑ Step 20. Align the flat sections on the one-way/clicker plate (25) with the flat sections on the shaft (7). Place the one-way/clicker plate (25) next to the one-way/clicker pulley (24), aligning the teeth on both parts.

❑ Step 21. Center the one-way adjustment spring (26) on the end of the one-way/clicker plate (25). Position the adjustment spring washer (27), small side first, over the shaft (7) and in the end of the spring (26).

❑ Step 22. Thread the 4-40 mini locknut (28) onto the end of the shaft (7). Tighten the nut (28) all the way, then back it off two full turns (360° x 2). This should be a good initial adjustment.

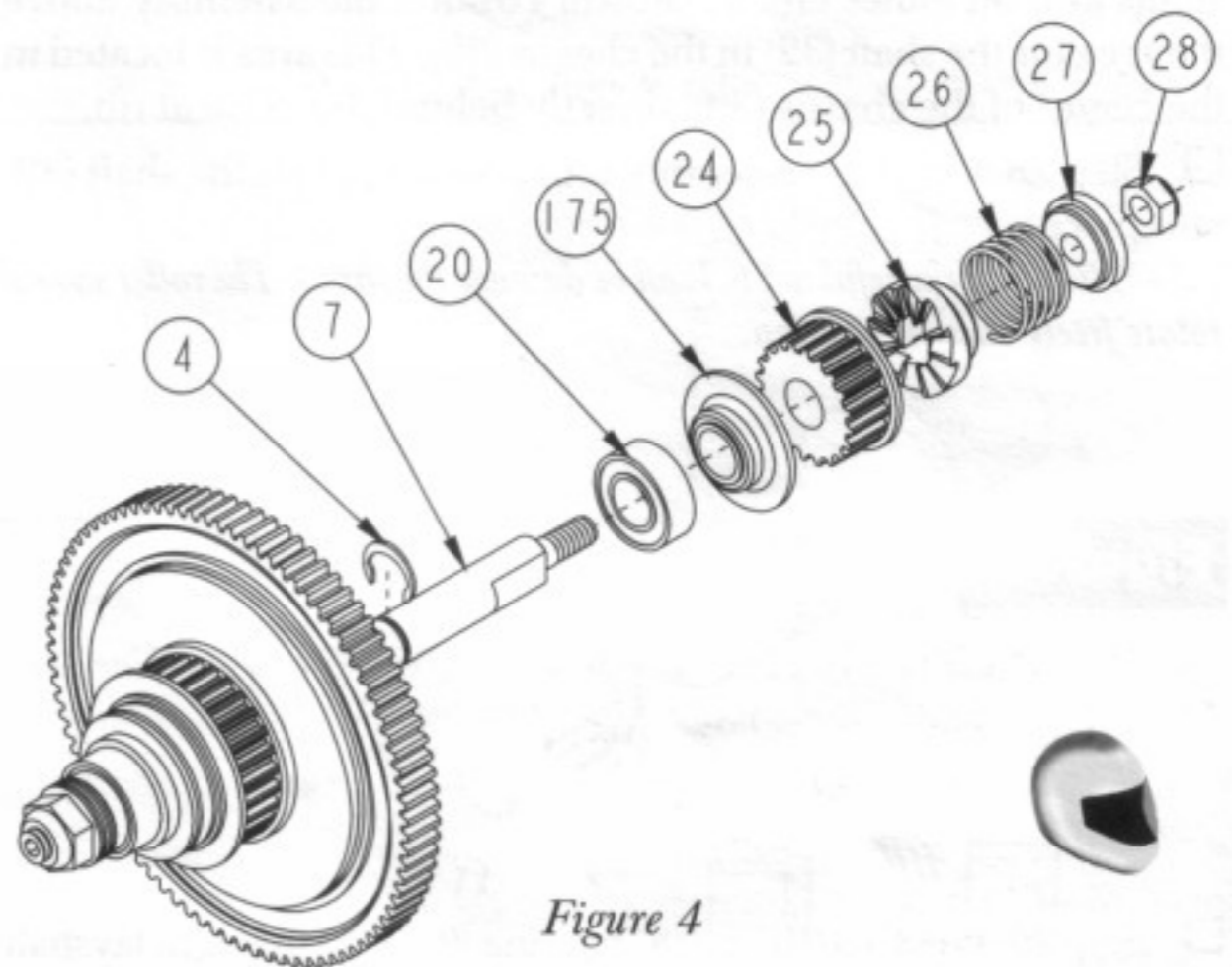


Figure 4

## Figure 5

❑ Step 23. Place a short 2mm drive belt (29) over each of the pulleys (14), (24).

❑ Step 24. With the belts (29) in place, install the slipper shaft assembly in the forward area of the chassis (30) with the spur gear (12) to the right side of the chassis (30).

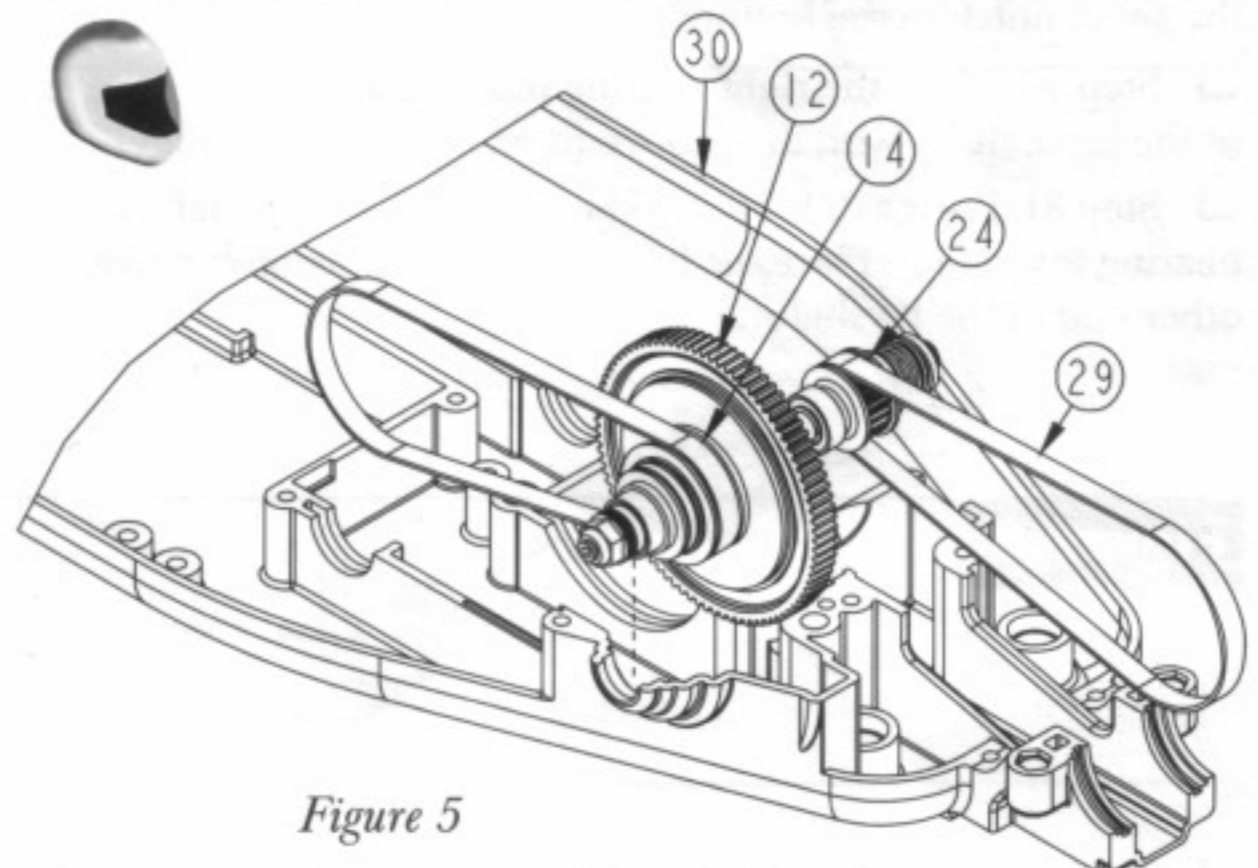


Figure 5

## Figure 6



❑ Step 25. Apply a small amount of white thrust bearing/assembly grease (49) to the belt roller shaft (32) and center the belt roller (31) on the belt roller shaft (32).

❑ Step 26. Place a 3/32" shim (33) over each end of the belt roller shaft (32).

🔧 Team Losi offers a bearing belt roller kit (A-6912). This kit replaces the bushing belt rollers in the kit with small ball bearings.

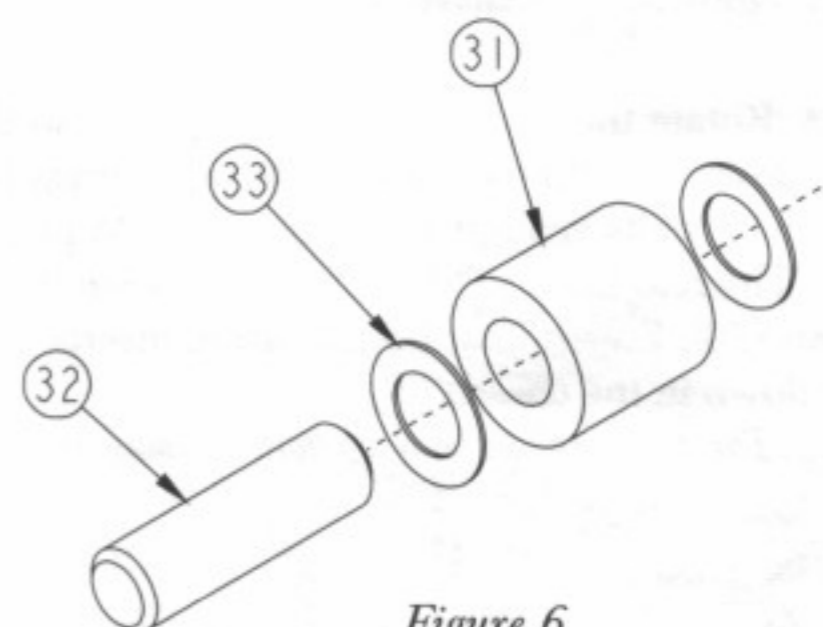


Figure 6

# BAG A (Continued)

## Figure 7

❑ Step 27. Carefully pick up the belt roller assembly using a pair of tweezers or small needle-nose pliers. Hold the assembly by the shims (33) on either end as shown. Position the assembly above the area for the shaft (32) in the chassis (30). This area is located in the center of the chassis (30), directly behind the vertical rib.

❑ Step 28. Once the assembly is in position, press the shaft (32) into place.

*\*NOTE: Be careful not to bend or damage the shims. The roller should rotate freely once in position.*

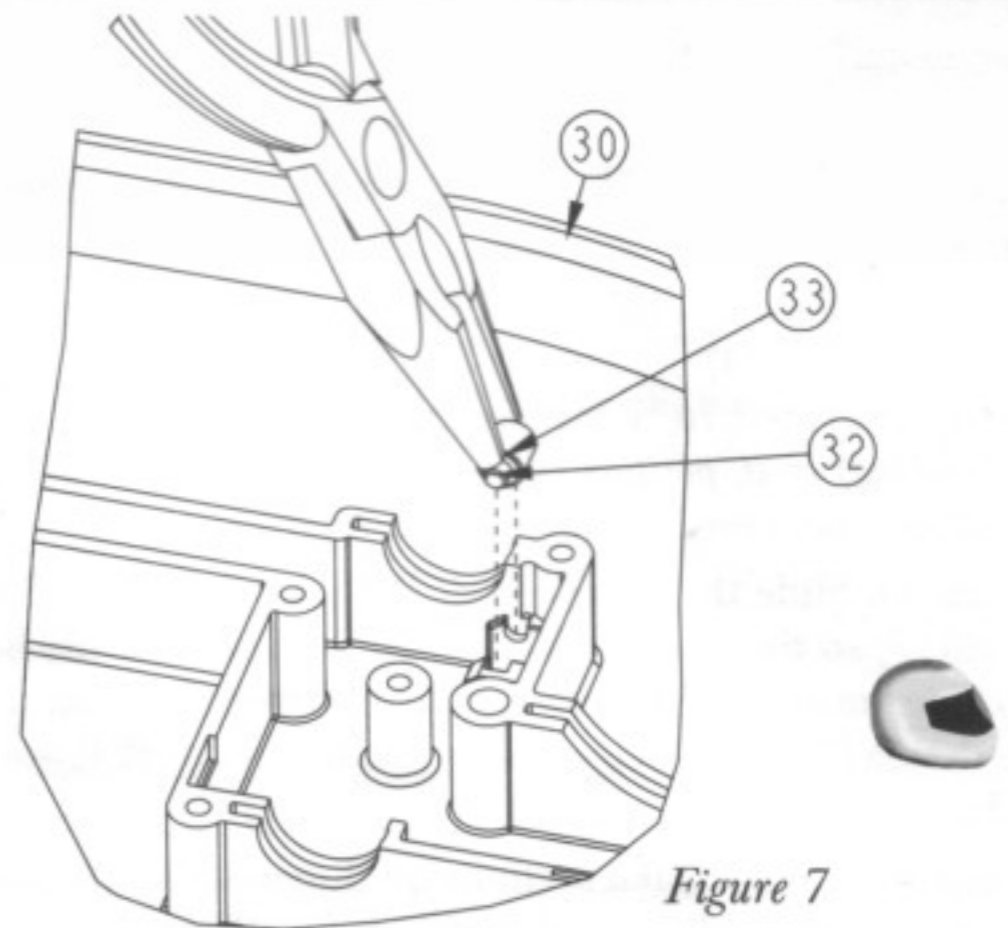


Figure 7

## Figure 8

❑ Step 29. Press a 3/16" x 3/8" bearing (20) into the right layshaft bearing insert (34). The right bearing insert (34) is the one with the small notch in the bottom corner.

❑ Step 30. Place the right bearing insert assembly over the end of the layshaft (2) with the groove (next to the large pulley).

❑ Step 31. Press a 3/16" x 3/8" bearing (20) into the left layshaft bearing insert (35). Place the left bearing insert assembly over the other end of the layshaft (2).

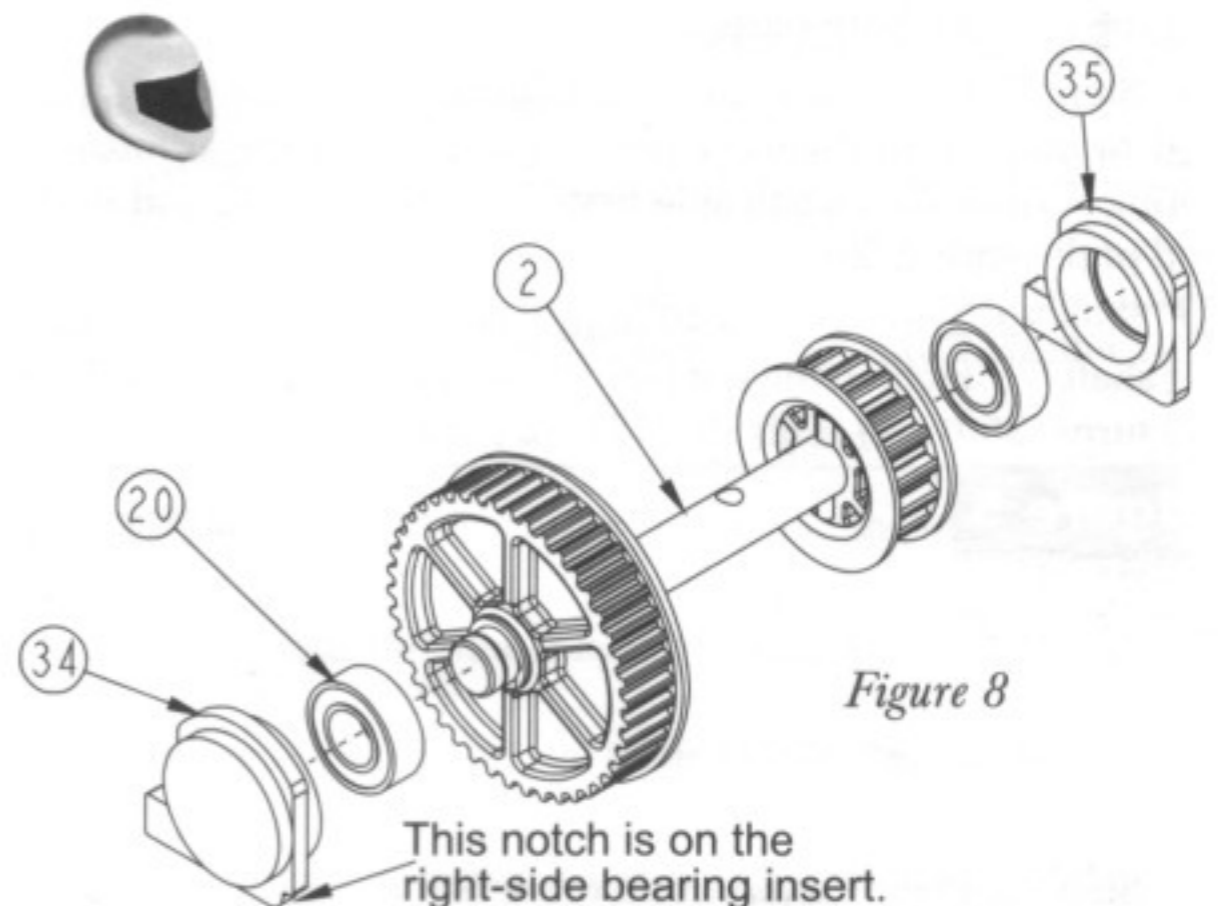


Figure 8

## Figure 9

❑ Step 32. Wrap the rear drive belt (36) around the small pulley (5) and hold the belt (36) tightly around the pulley (5).

❑ Step 33. Hook the side drive belt (29) around the large pulley (3).

❑ Step 34. Rotate the bearing inserts (34), (35) so that the flat edges faces down and the tabs are to the rear. Press the layshaft assembly – with belts around the pulleys – into position in the chassis (30). The rear belt (36) should run between the center ribs of the chassis (30). Ensure that both bearing inserts (34), (35) are all the way down in the chassis (30).

*\*NOTE: The top, exposed end of both bearing inserts should be rounded.*

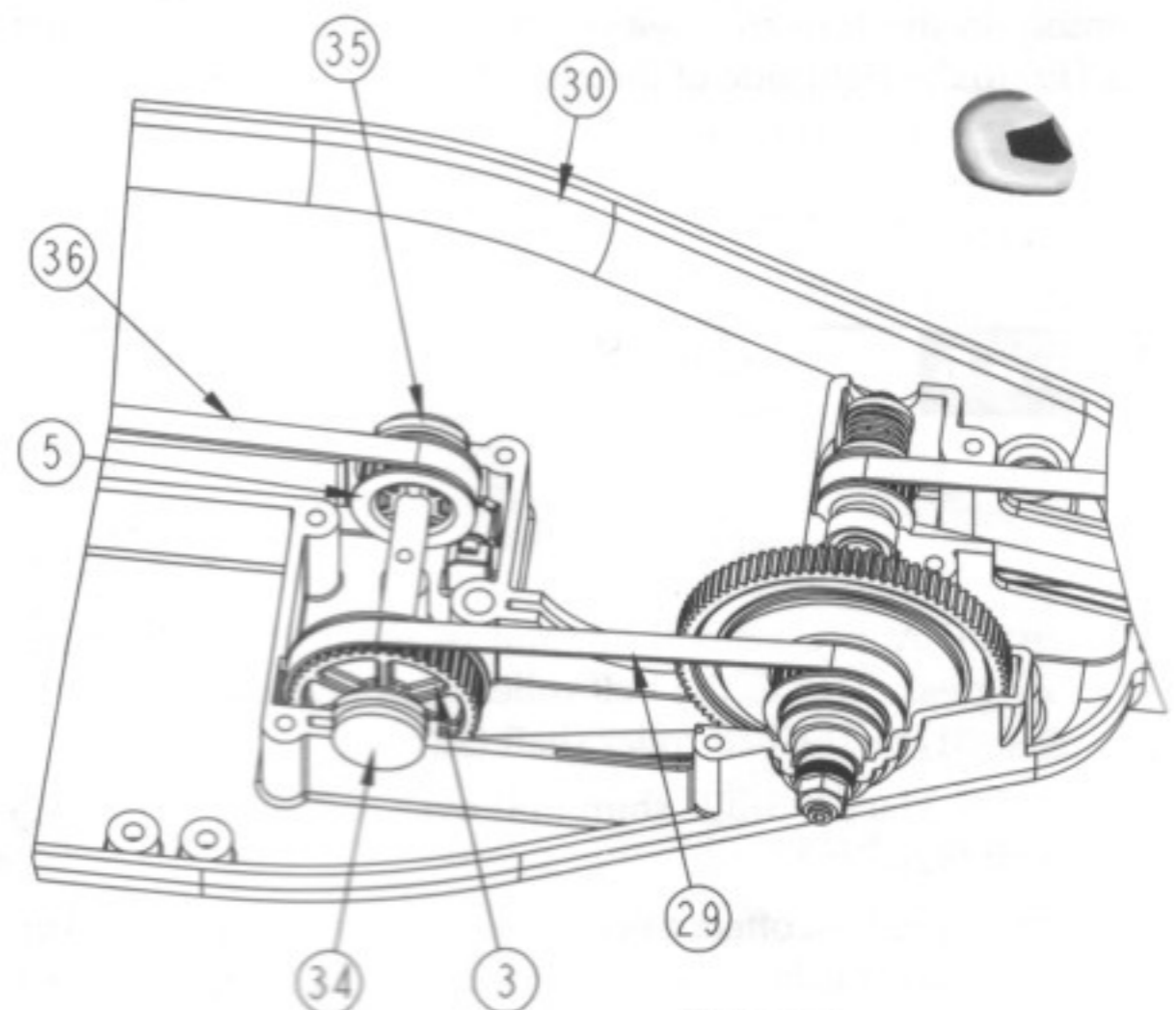


Figure 9

# BAG B

**Figure 10**



- ❑ Step 1. Insert a 4-40 mini lock nut (28) into the hex area of the diff nut carrier (37). The thread-locking portion of the nut (28) should face the outside.

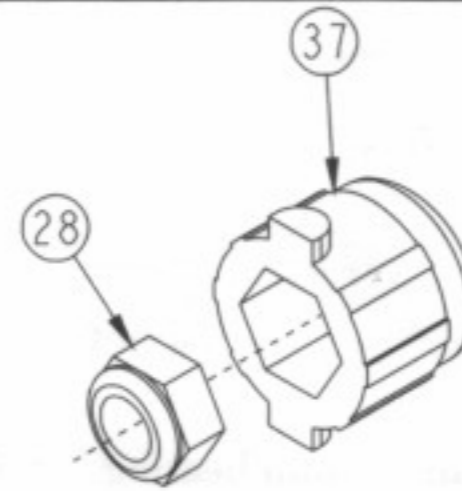


Figure 10

**Figure 11**



- ❑ Step 2. Locate the 5/64" Allen wrench (9) supplied with the kit. Place the diff nut carrier (37), nut side first, over the Allen wrench.
- ❑ Step 3. Stack the six 1/8" Belleville washers (22) over the wrench, next to the diff nut carrier (37). The washers (22) should all point the same direction and open away from the nut carrier (37) as shown in Figure 11A.
- ❑ Step 4. Place the diff tube (38) over the wrench, big side first, so that the tube (38) rests against the Belleville washers (22).

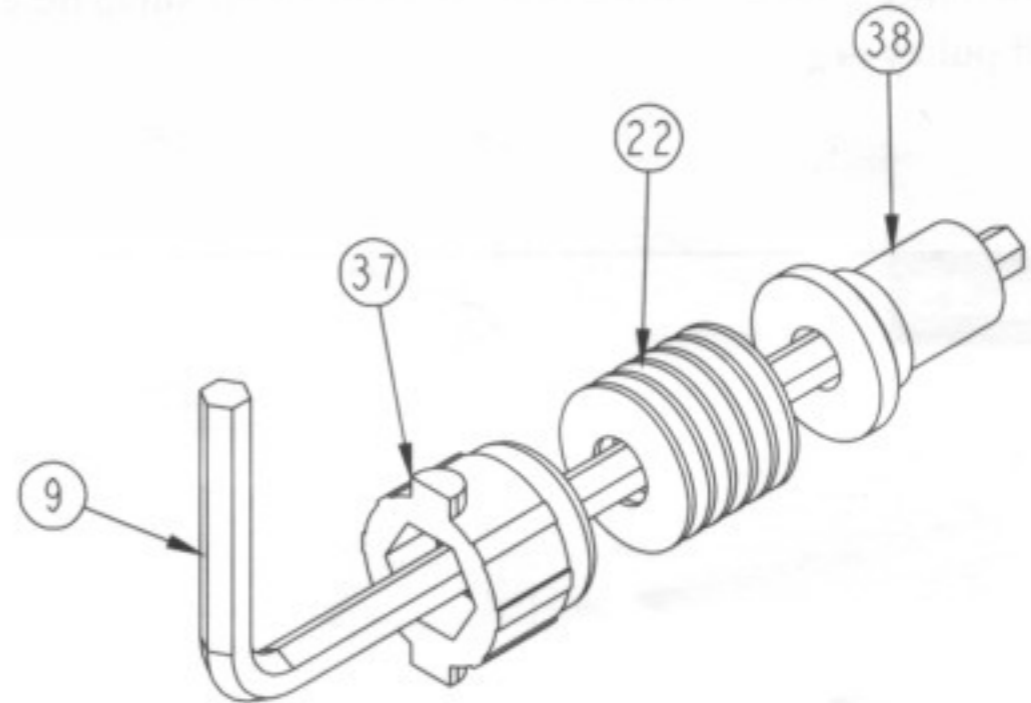
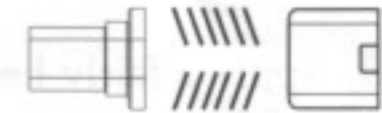


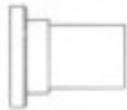
Figure 11



Belleville washers should face this direction

Figure 11A

**Figure 12**



- ❑ Step 5. Insert all of the parts that are stacked on the wrench into one of the steel outdrive/diff halves (39). Line up the tabs on the diff nut carrier (37) with the slots in the outdrive (39). Make certain that the diff tube (38) is pressed all the way into the outdrive/diff half (39), and that the tube (38) is straight. There is a small shoulder on the diff tube (38) that should be flush with the outer surface of the outdrive (39).

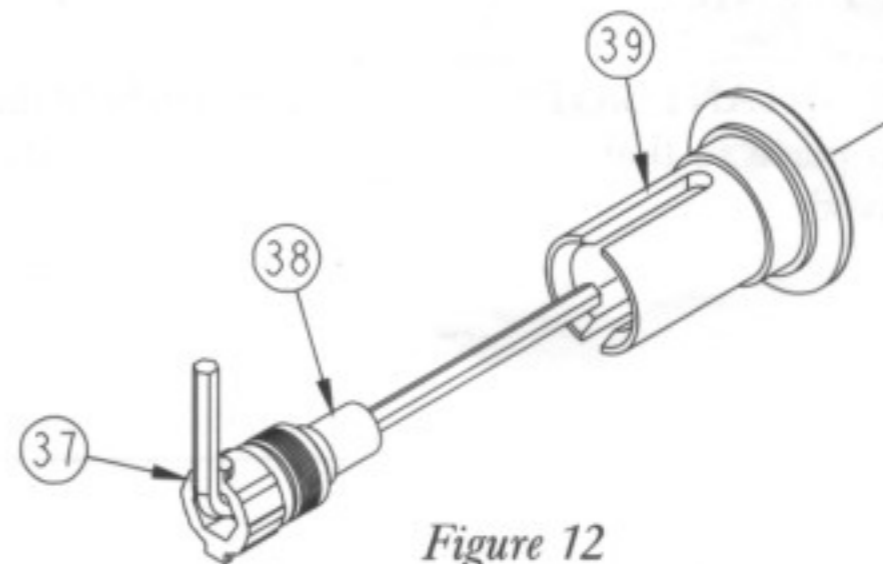


Figure 12

**Figure 13**



- ❑ Step 6. Apply a small amount of diff grease (40) (clear) to the outside ring of the outdrive (39). Attach a diff drive ring (41) to the outdrive (39) by lining up the slot in the ring (41) with the slot in the outdrive (39).

*\*NOTE: The diff grease is the clear grease— not the white colored grease. Only a small amount of grease is needed. It is only there to hold the drive ring in place.*

**! IMPORTANT NOTE:** Do not glue the drive rings to the outdrive/diff halves. Doing so may not allow the washers to mount flat.

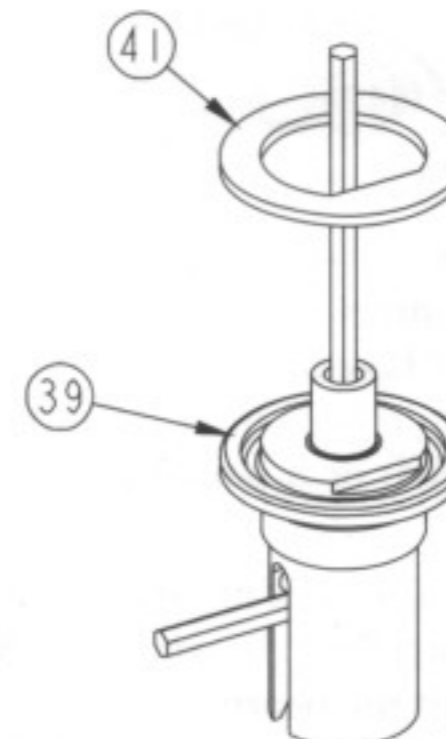
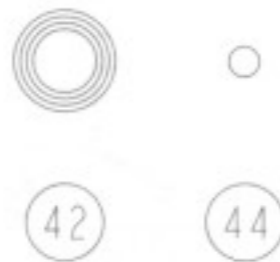


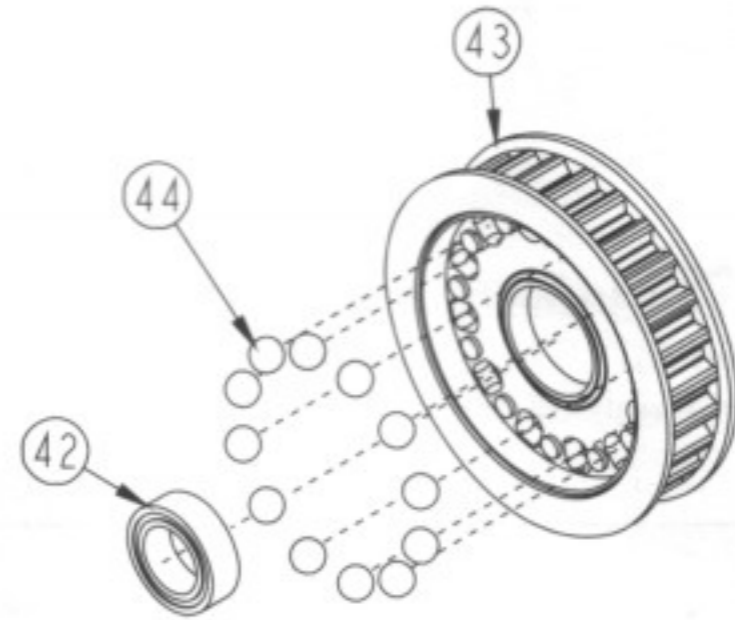
Figure 13

# BAG B (Continued)

**Figure 14**



- ❑ Step 7. Insert a 5mm x 8mm bearing (42) into the center of the rear diff pulley (43).
- ❑ Step 8. Press a 3/32" diff ball (44) into each of the small holes in the diff pulley (43).

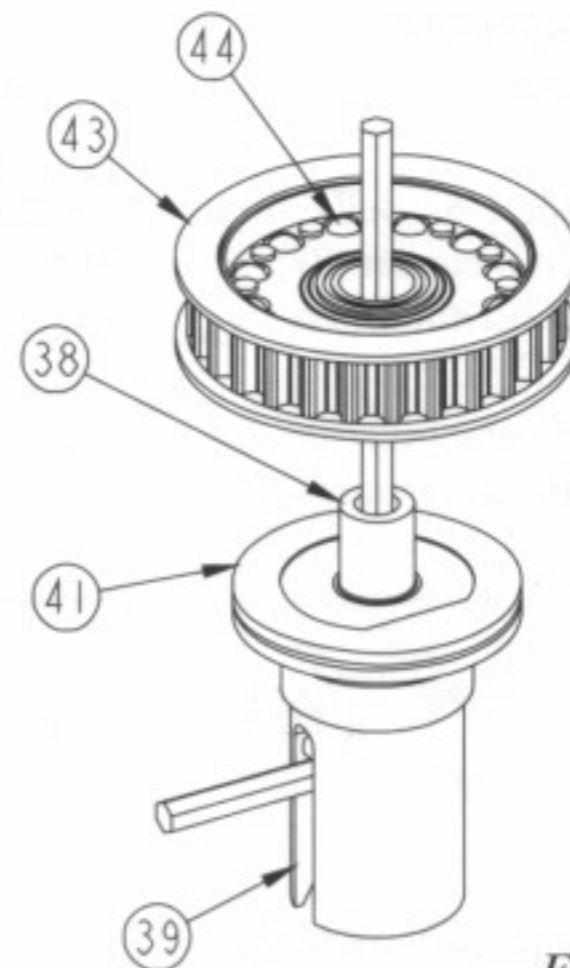


*Figure 14*

**Figure 15**

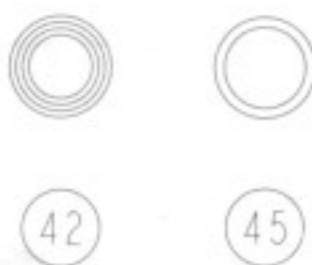
- ❑ Step 9. Apply a fairly heavy coat of diff grease (40) to the exposed side of the drive ring (41) that is already attached to the outdrive (39).
- ❑ Step 10. Carefully place the diff pulley (43) over the diff tube (38) so that the diff balls (44) and diff pulley (43) rest against the greased drive ring (41).

**⚠ IMPORTANT NOTE:** It is a good idea to hold the diff nut carrier in place so that when installing the pulley, the diff tube isn't moved.



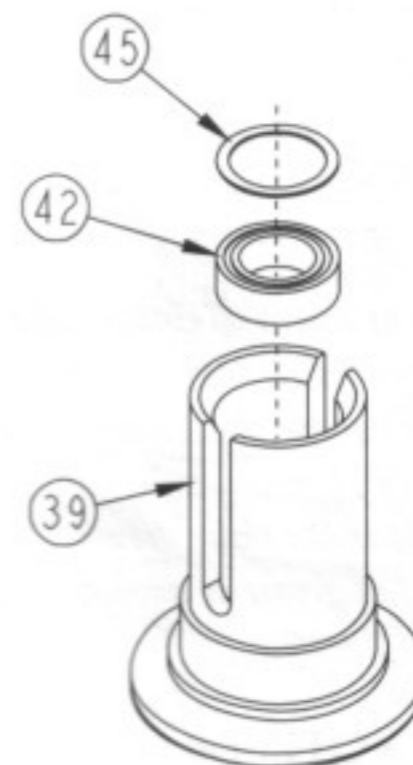
*Figure 15*

**Figure 16**



- ❑ Step 11. Insert a 5mm x 8mm bearing (42) into the second outdrive/diff half (39). Make sure that the bearing (42) is pushed all the way into the outdrive (39). The handle of a hobby knife (with the blade removed) or a pencil can be used to push the bearing (42) into place.
- ❑ Step 12. Drop the 1/4" x 5/16" shim (45) into the outdrive (39), on top of the 5mm x 8mm bearing (42). Make sure that the shim (45) sits flat against the bearing (42).

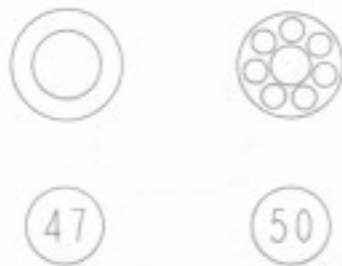
*\*NOTE: Be extra careful not to bend the shim!*



*Figure 16*

# BAG B (Continued)

**Figure 17**



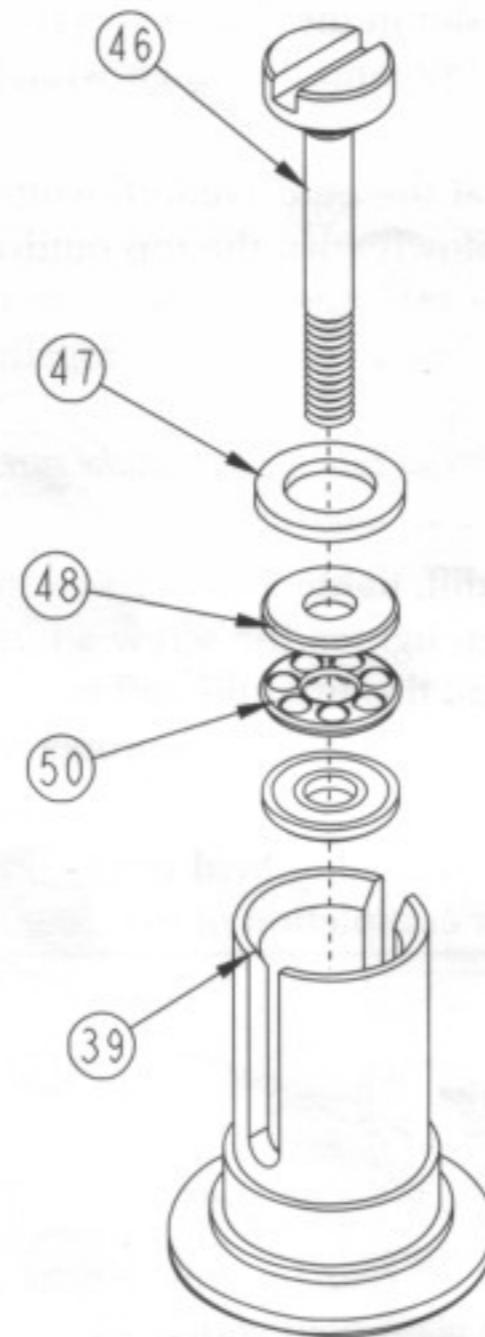
❑ Step 13. Locate the diff adjusting screw (46) and place the foam thrust bearing seal (47) over the shoulder of the screw (46).

❑ Step 14. Place one of the 3mm x 8mm raced thrust bearing washers (48) over the diff screw (46) so that the groove in the washer (48) faces up.

❑ Step 15. Using the white thrust bearing/assembly grease (49), liberally grease the thrust washer (48) and place the 3mm x 8mm thrust bearing (50) over the screw (46), and next to the washer (48). Apply white thrust bearing/assembly grease (49) to the exposed side of the thrust bearing (50) and place the second thrust bearing washer (48) over the screw (46), against the thrust bearing (50). This time, the groove in the thrust washer (48) should face down.

*\*NOTE: The thrust bearing/assembly grease is the white colored grease – not the clear grease.*

❑ Step 16. Very carefully insert the diff screw (46), with the thrust bearing assembly installed, into the outdrive (39). Be extremely careful not to bend or pinch the shim (45) while inserting the diff screw (46). Pull the threaded end of the diff screw (46) until the thrust bearing assembly rests against the shim (45), next to the bearing (42) inside the outdrive (39).



*Figure 17*

**Figure 18**



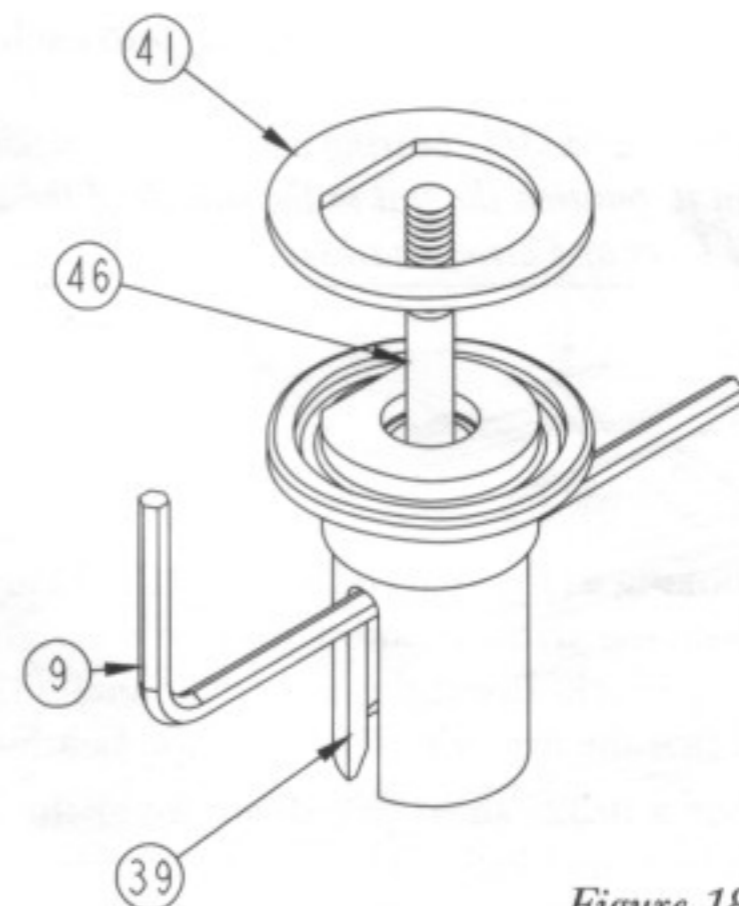
❑ Step 17. Locate the smallest of the supplied Allen wrenches (9) and place it in the slot in the outdrive (39) containing the diff screw (46). Slide the wrench all the way into the slot in the outdrive (39) against the screw (46). Handling the outdrive (39) with the wrench inserted, will hold the diff screw (46) in place while finishing assembly of the diff.

❑ Step 18. Apply a small amount of clear diff grease (40) to the outer ring of the outdrive (39). Install the second drive ring (41), again aligning the slots in the outdrive (39) and the drive ring (41).

*\*NOTE: The diff grease is the clear grease – not the white colored grease. Only a small amount of grease is needed. It is only there to hold the drive ring in place.*

❑ Step 19. Apply a fairly heavy coat of clear diff grease (40) to the exposed side of the drive ring (41).

🔑 For best results, clean the drive rings with rubbing alcohol or motor spray before applying the grease to the exposed side.



*Figure 18*

# BAG B (Continued)

## Figure 19

- ❑ Step 20. While holding the outdrive (39) with the Allen wrench inserted, carefully assemble it to the other outdrive/diff half (39).
- ❑ Step 21. Make sure that the slot in the diff screw (46) is lined up with the slot in the outdrive (39) and the Allen wrench is inserted in the diff screw (46).
- ❑ Step 22. Hold the diff so that the outdrive (39) with the diff nut carrier (37) is pointing up. Slowly turn the top outdrive (39) clockwise to thread the diff screw (46) into the 4-40 mini nut (28) in the diff nut carrier (37). Thread the two outdrives together until the screw (46) just starts to snug up.

*\*NOTE: If the screw will not thread into the nut, make sure that the nut carrier is pushed all the way into the outdrive.*

🔑 When tightening the diff, tighten the screw a little and then "work" the diff a little. Then tighten the screw a little more and work the diff again. Continue this until the diff is tight. This will ensure that all the parts in the diff assembly are properly seated.

- ❑ Step 23. Tighten the diff until the pulley (43) cannot be turned while both of the outdrives (39) are being held firmly. Final diff adjustment should be made after completion of the car.

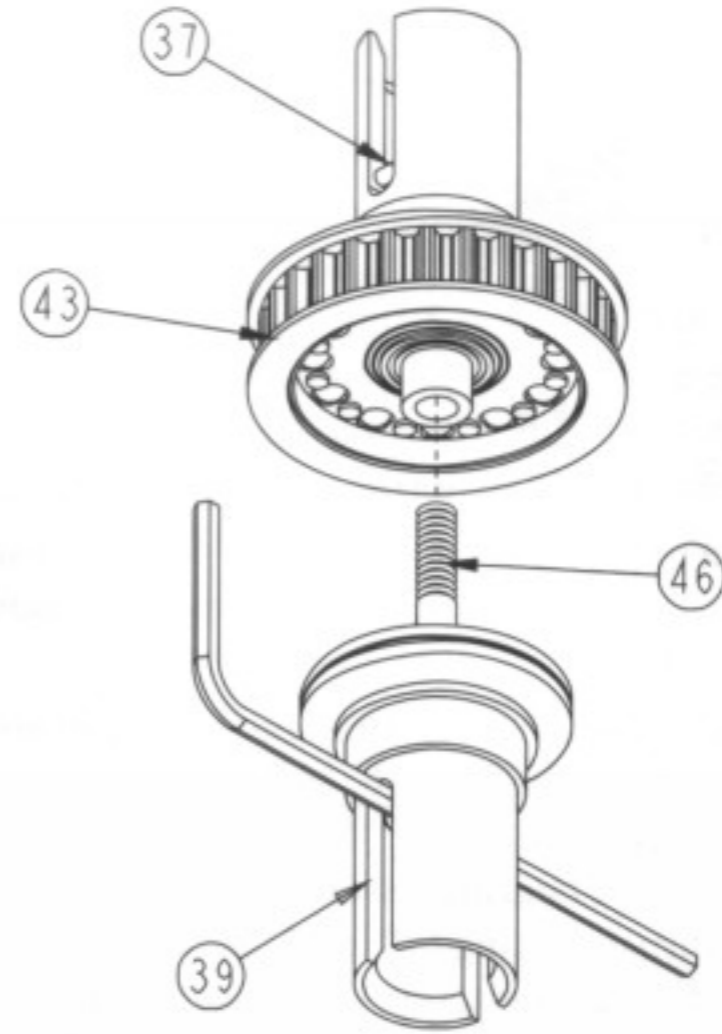


Figure 19

## Figure 20



- ❑ Step 24. There are two sets of rear bearing blocks (51) included in your XX-4 kit. One set is marked with the letter 'A', the other set with the letter 'B'. These two sets of bearing blocks allow for rear belt tension adjustment. The two sets of blocks can each be oriented two different ways to allow for four different tension settings. Look for more about rear belt tension adjustment in the tips section of the manual.

Locate the set of blocks marked 'B'. This is the set that will be used to assemble the car. You will want to keep the 'A' set in your spare parts.

- ❑ Step 25. Press a 1/2" x 3/4" bearing (52) into each of the rear bearing blocks (51) marked 'B'.

*\*NOTE: If the 1/2" x 3/4" bearing only has one Teflon™ seal (tan, woven looking) in it, position the seal to the outside of the bearing block (the side with the letter and arrow markings).*

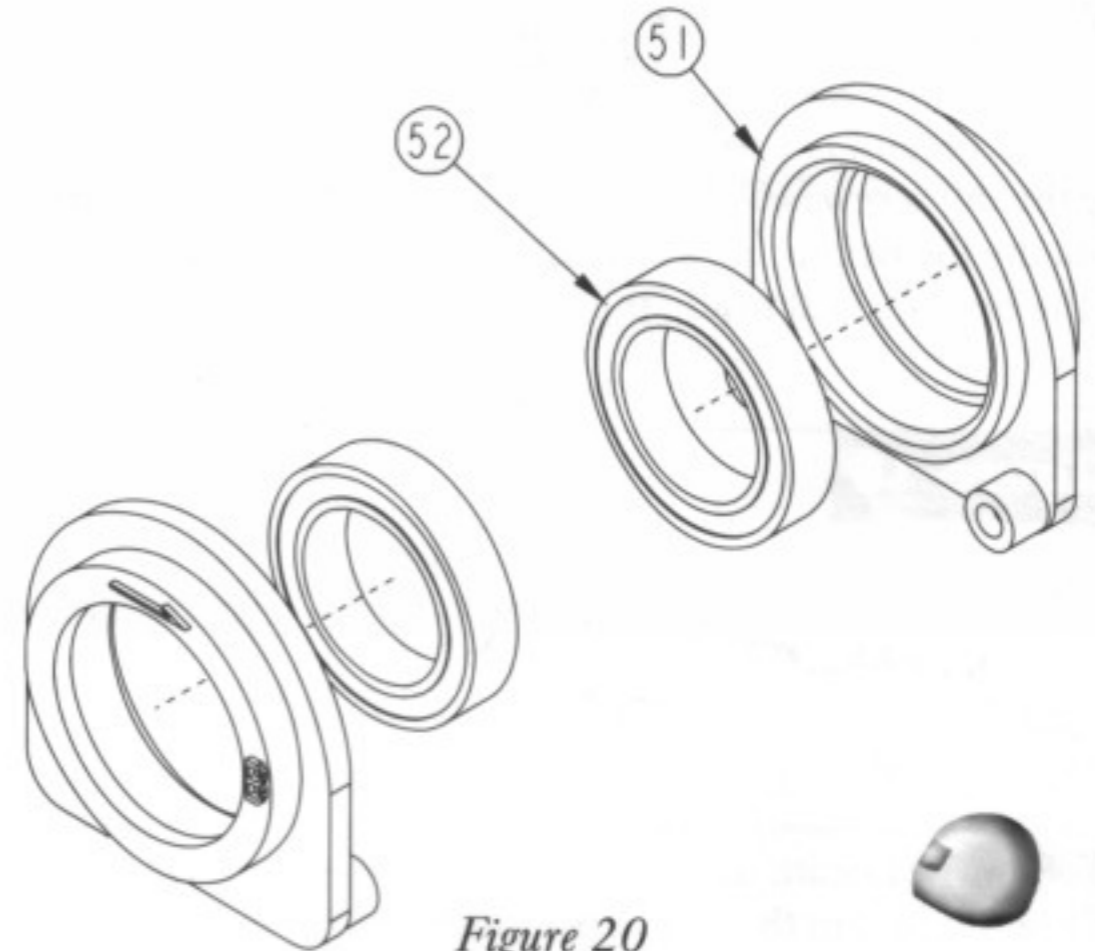


Figure 20

## Figure 21



- ❑ Step 26. Looking at the marked sides of the bearing blocks, locate the one with the arrow pointing from left-to-right. This will be the left bearing block. Insert the belt roller shaft (32) into hole in the rear (end that the arrow points to) of the bearing block.

- ❑ Step 27. Slide a 3/32" shim (33) down, over the roller shaft (32), next to the bearing block (51).

- ❑ Step 28. Apply a small amount of white thrust bearing/assembly grease (49) to the shaft (32) and position the belt roller (31) on the shaft (32), next to the shim (33), followed by the second shim (33).

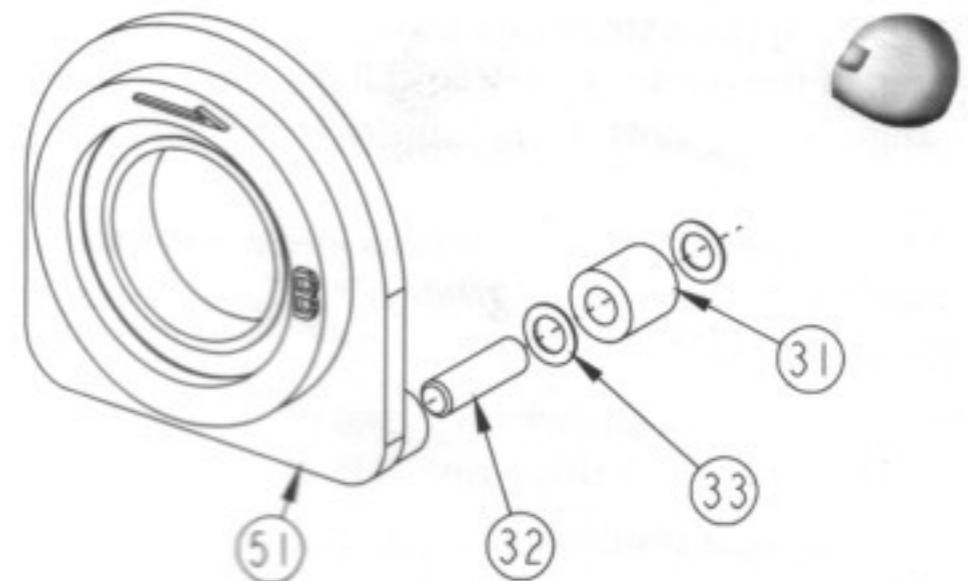


Figure 21

# BAG B (Continued)

## Figure 22

- ❑ Step 29. Position the rear differential in the center of the rear drive belt (36) so that the slot in the diff adjusting screw (46) faces to the left.
- ❑ Step 30. Pull the rear diff back so that the rear belt (36) wraps around the rear diff pulley (43). Ensure that the teeth on the belt (36) engage with the teeth on the pulley (43).
- ❑ Step 31. While holding the rear belt (36) around the rear diff pulley (43), carefully place the left rear bearing block assembly over the left side of the differential. The flat side of the rear bearing block (51) should be on the bottom (closest to the chassis) and the belt (36) should be positioned between the pulley (43) and the belt roller (31).
- ❑ Step 32. Place the right bearing block (51) over the other side of the differential. Align the hole in the rear of the block (51) with the roller shaft (32) and carefully slide the bearing block (51) over the outdrive (39) until the roller shaft (32) is inserted in the hole in the bearing block (51).

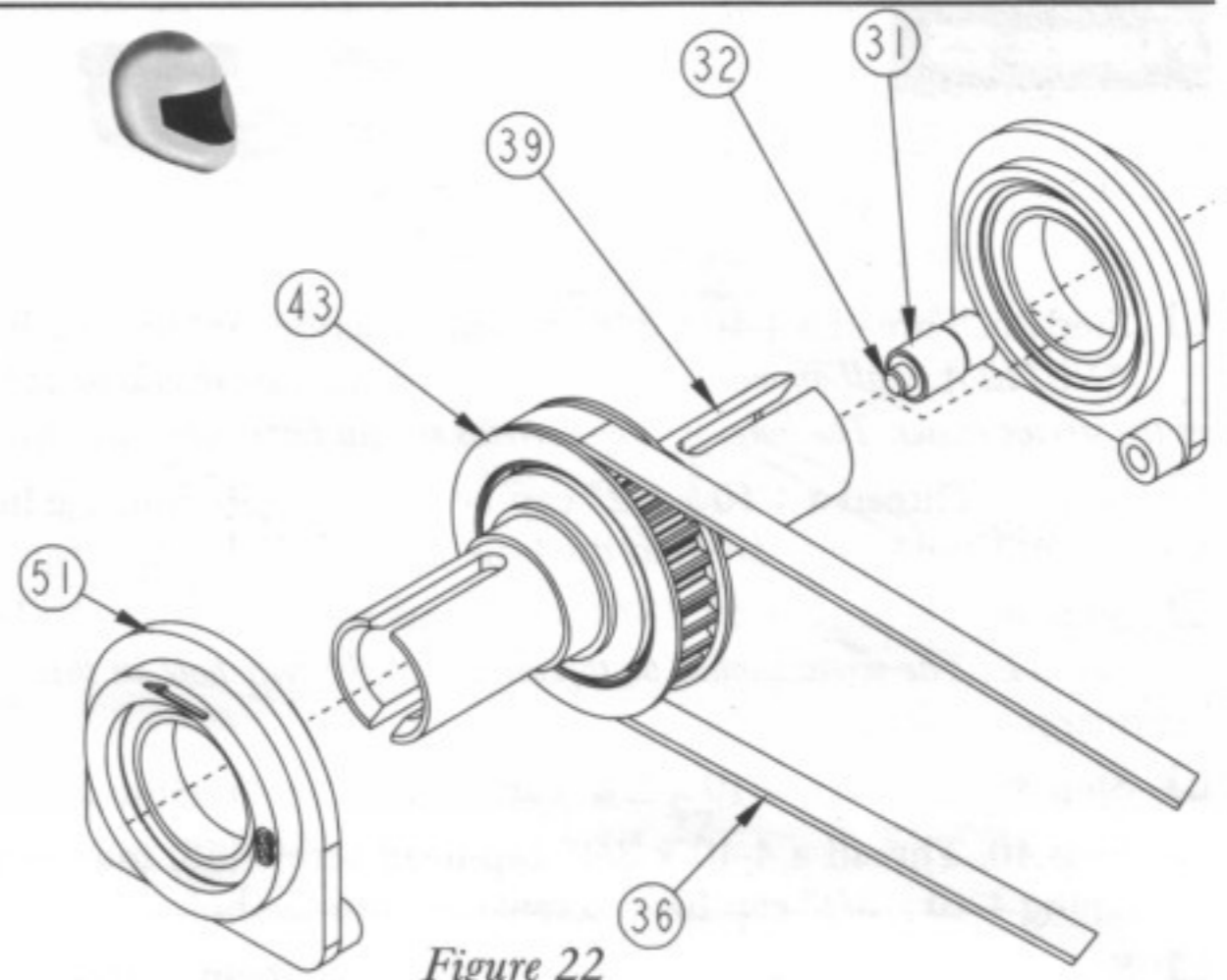


Figure 22

## Figure 23

- ❑ Step 33. With the flat side of the bearing blocks (51) to the bottom (closest to the chassis) and the roller to the rear, install the rear diff/bearing block assembly, with the arrows pointing rearward, in the rear portion of the chassis. Press the assembly all the way down into the chassis.

**⚠ IMPORTANT NOTE:** At this time you should check the belt tension. Due to production tolerances, belts vary slightly in length. To check the belt tension, hold the pulley on the idler shaft firmly in place. While holding the idler shaft pulley, rotate the rear diff pulley toward the idler pulley as much as you can, creating slack at the top of the belt. If the belt is adjusted correctly, there should be about 1/8"-1/4" of slack at the top of the belt. If the belt appears to be either too loose or too tight, refer to table 23 to find the desired tension and change the blocks accordingly. **Make sure that the belt roller is in place!**

Bearing Block & Direction	Adjustment
'A' - arrow pointing back	Tightest
'B' - arrow pointing back	Tight
'B' - arrow pointing forward	Loose
'A' - arrow pointing forward	Loosest

Table 23

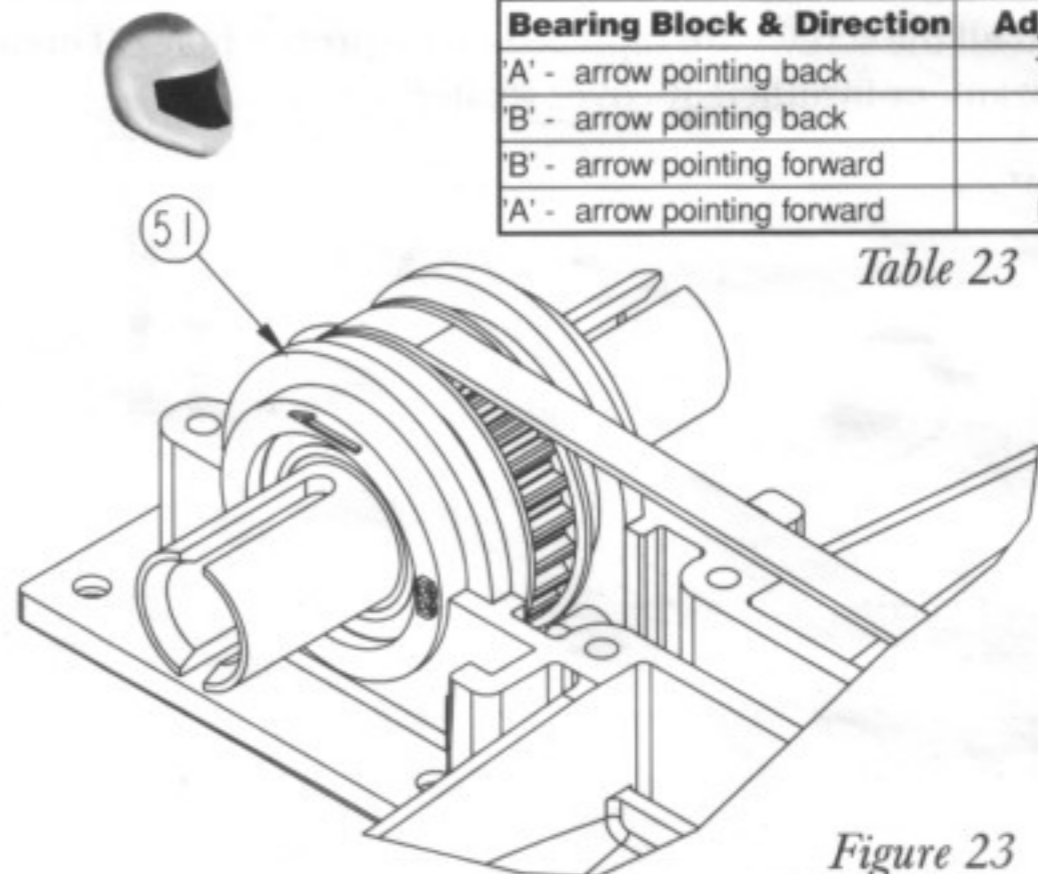
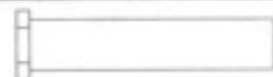


Figure 23

## Figure 24



(54)

⚙ Before continuing to step 34, locate the 4-40 thread-forming screw packed in the Allen wrench bag. Use this self-tapping screw to form threads in all of the holes in the top side of the chassis (11 total). This is accomplished by threading the screw all the way into the hole, and then removing the screw from the hole. Threading these holes before continuing to step 34 will make assembly much easier. It is recommended that you apply a small amount of white assembly grease to the self-tapping screws before threading them into the holes.

- ❑ Step 34. Place the main chassis cover (53) on the chassis (30) as shown. Ensure that the cover (53) is all the way down, and flush against the chassis (30).

- ❑ Step 35. Insert the two long threaded inserts (54) into the two holes, with hexes at the top, in the forward area of the cover (53) as shown. While lining up the hexes on the inserts (54) with the hex area in the cover (53), press the inserts (54) down, into the hex area of the cover (53).

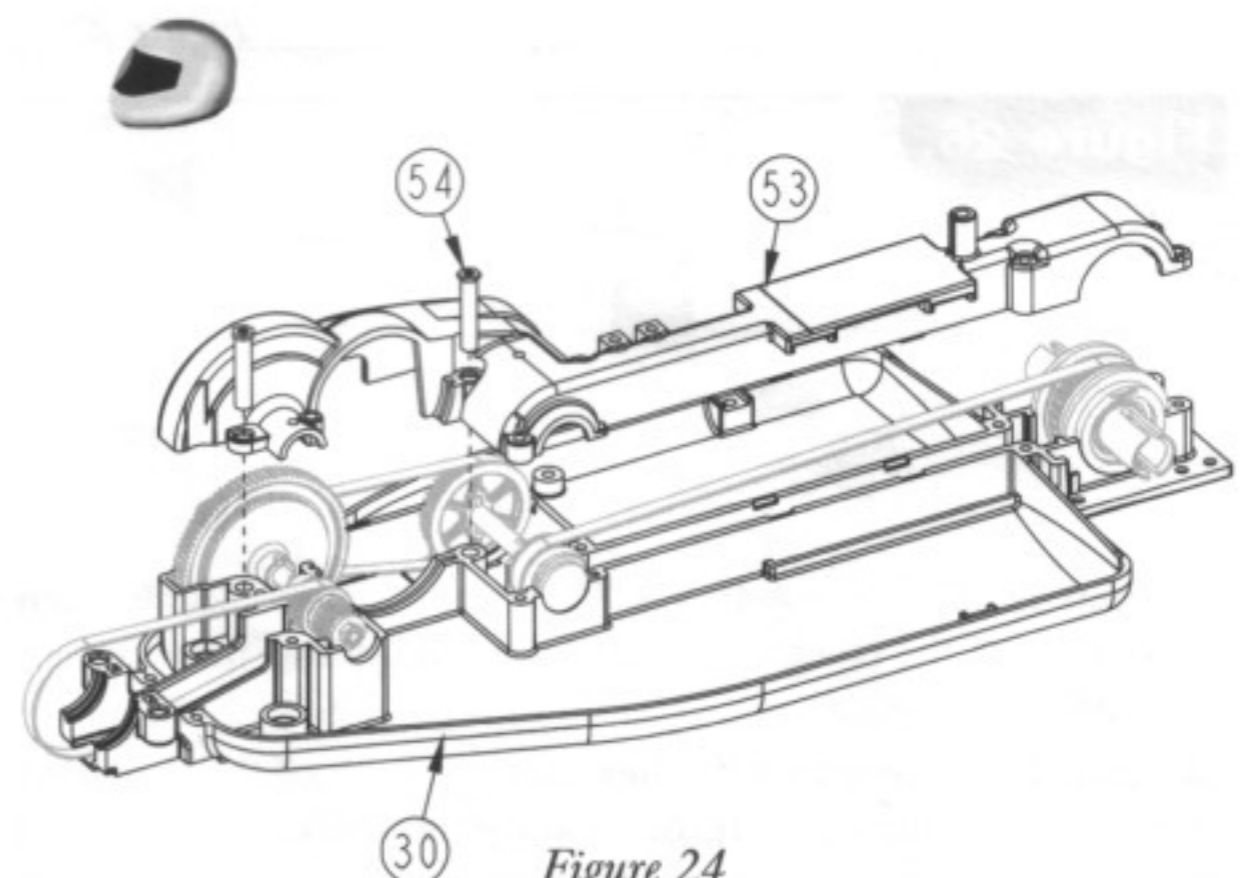
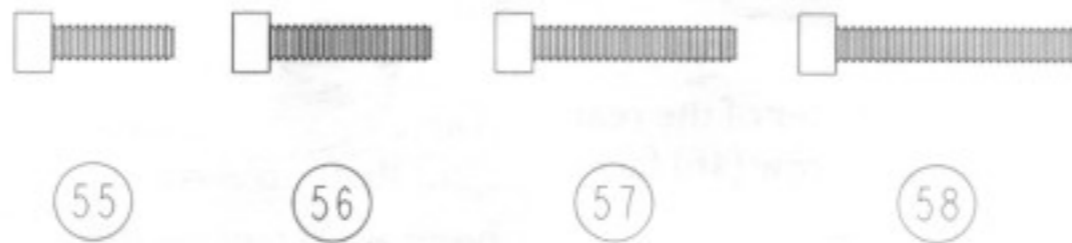


Figure 24

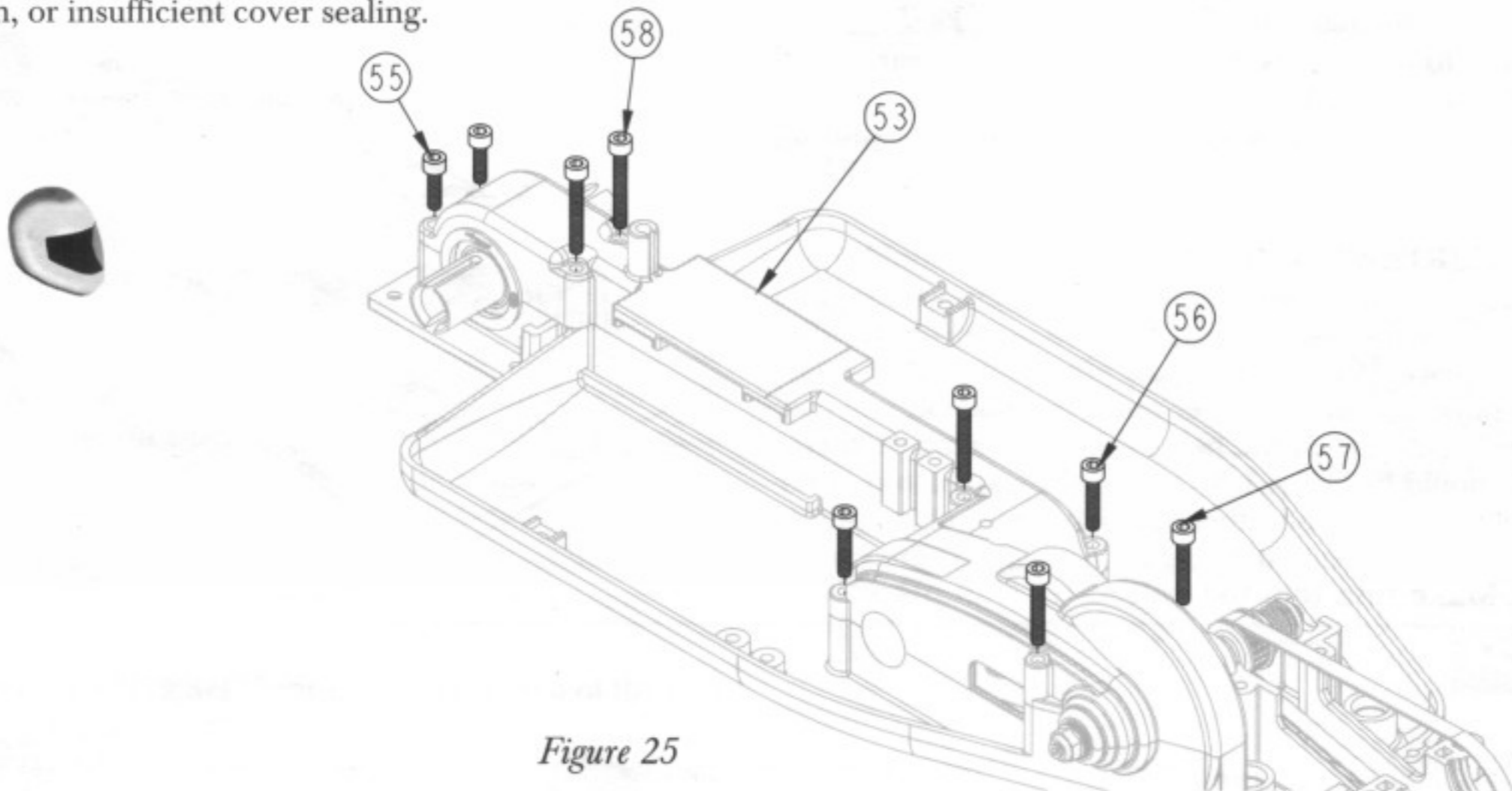
# BAG B (Continued)

**Figure 25.**



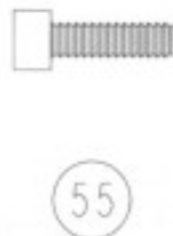
- ❑ Step 36. Thread a 4-40 x 3/8" cap-head screw (55) into each of the two rear-most holes in the cover (53).  
*\*NOTE: A small amount of the white assembly grease should be applied to the threads of all the screws in Figure 25. This will make installation of the screws easier. The holes for these screws should have been threaded with the thread-forming screw as indicated prior to step 34.*
- ❑ Step 37. Thread a 4-40 x 1/2" cap-head screw (56) into the hole to the left of the rear threaded insert (54). Thread a second 4-40 x 1/2" cap-head screw (56) into the hole behind, and to the right of, the rear threaded insert (54).
- ❑ Step 38. Thread a 4-40 x 5/8" cap-head screw (57) into the hole to the right of the one-way/clicker pulley (24).  
*\*NOTE: The screw should be threaded into the rear hole in this area. The forward of the two holes will be used for differential and slipper adjustment at a later time.*
- ❑ Step 39. Thread a 4-40 x 5/8" cap-head screw (57) into the hole just behind the slipper adjustment nut (23).
- ❑ Step 40. Thread a 4-40 x 3/4" cap-head screw (58) into each of the two holes just in front of the rear differential. Thread the remaining 4-40 x 3/4" cap-head screw (58) into the hole in the corner of the cover (53) just behind the layshaft area.
- ❑ Step 41. Tighten all nine screws in Figure 25, being careful not to overtighten any of them.

🔑 When removing the main cover from the chassis, try to keep the screws for the cover in their respective holes. This will ensure that all the screws are replaced in the proper holes. Threading a screw that is too long into a hole may cause interference with the drive train, or insufficient cover sealing.

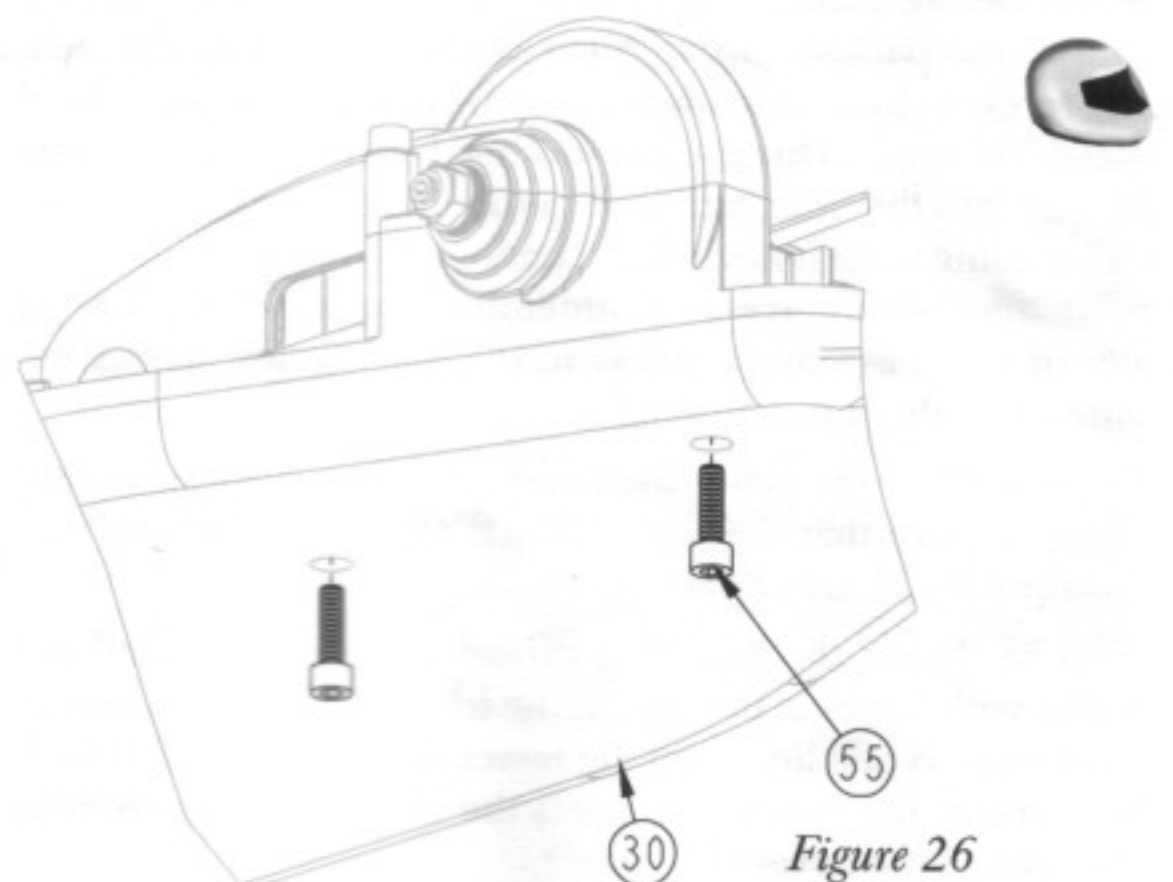


*Figure 25*

**Figure 26.**



- ❑ Step 42. Thread a 4-40 x 3/8" cap-head screw (55) through the bottom of the chassis (30), into each of the two threaded inserts (54).
- ❑ Step 43. Ensure that the hex area on both of the threaded inserts (54) is aligned with the hex area in the cover (53), and tighten both screws (55). Once the screws (55) are tight, the top of the hex on each of the threaded inserts (54) should be flush with the cover (53).



*Figure 26*

# BAG C

## Figure 27

- ❑ Step 1. Install the steering tunnel (59), tall end forward, in the front portion of the chassis (30) as shown. The top of the tunnel (59), when installed correctly, should be parallel to the chassis (30); and both the front and rear edges of the tunnel (59) should be vertical.
- ❑ Step 2. Press the tunnel (59) all the way down into position.

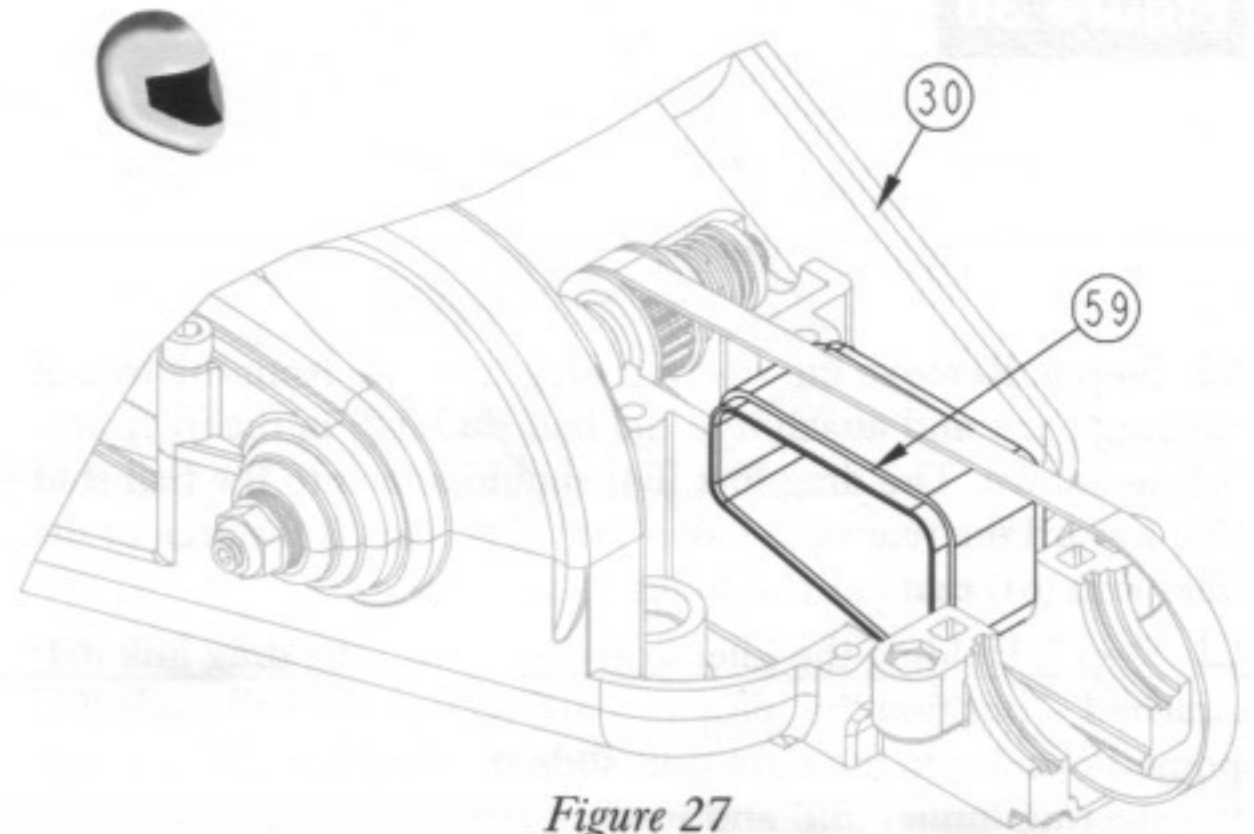


Figure 27

## Figure 28

- ❑ Step 3. Remove two 3/16" x 5/16" plastic steering bushings (60) from the steering parts tree. Press a bushing (60) into each of the two recessed areas at the front of the chassis (30).

**⚠ IMPORTANT NOTE:** Trim all flashing off of the bushings. If there is flashing present on the bushings when they are installed, the steering movement may be tight when assembly is complete.

🔑 Team Losi offers a sealed steering bearing set (A-6914).

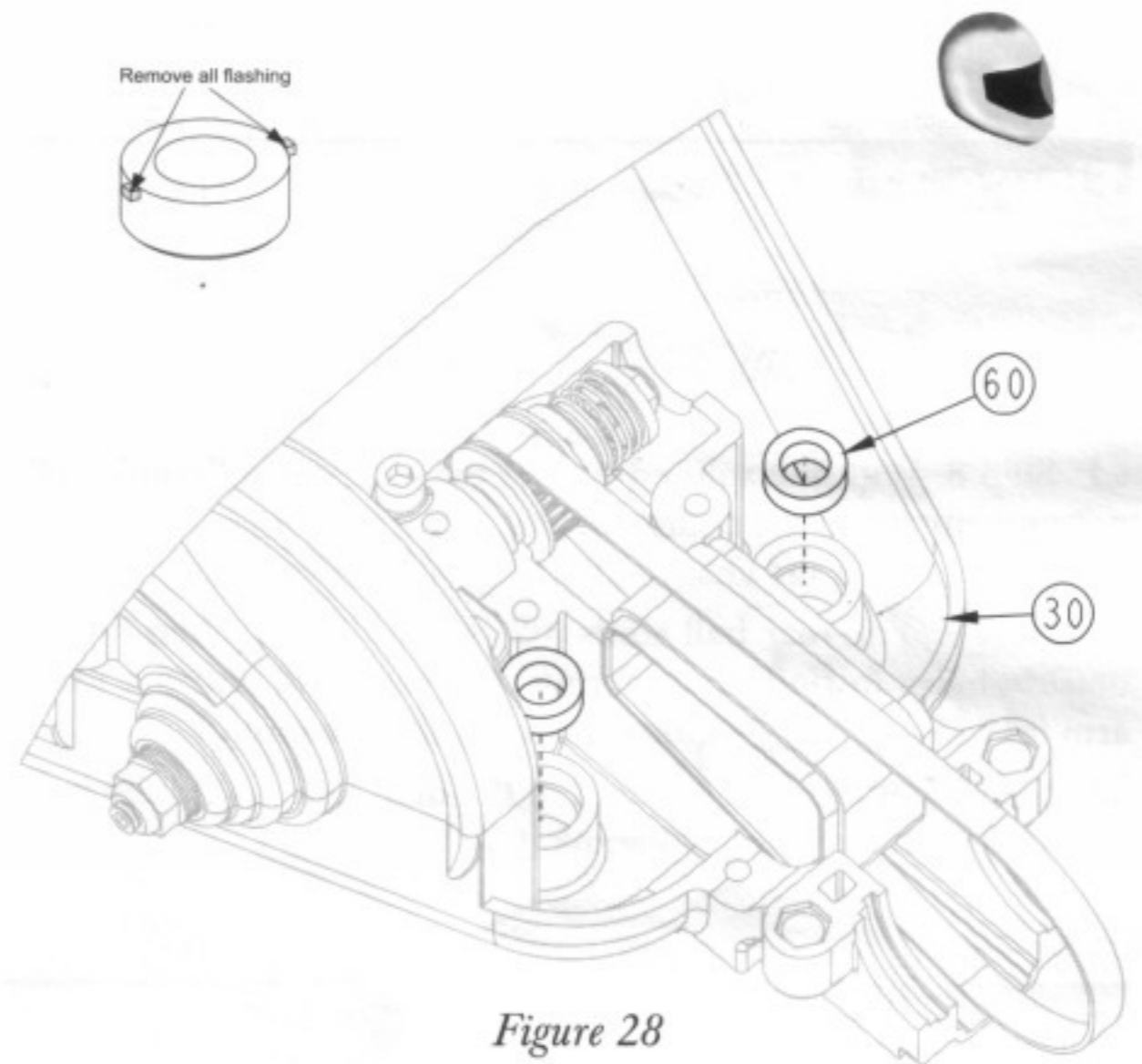
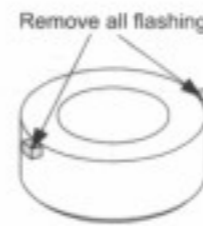


Figure 28

## Figure 29

- ❑ Step 4. Insert a 4-40 mini locknut (28) into the hex areas in the steering idler arm (61) as shown. Thread a 3/16" ball stud (62) into each nut (28), from the opposite side of the idler arm (61), and tighten.

*\*NOTE: The idler arm has no splines on the end of the shaft. The splines are on the steering bellcrank, used in step 5.*

- ❑ Step 5. Insert a 4-40 mini locknut (28) into the hex areas in the steering bellcrank (63) as shown. Thread a 3/16" ball stud (62) into each nut (28), from the opposite side of the bellcrank (63), and tighten.

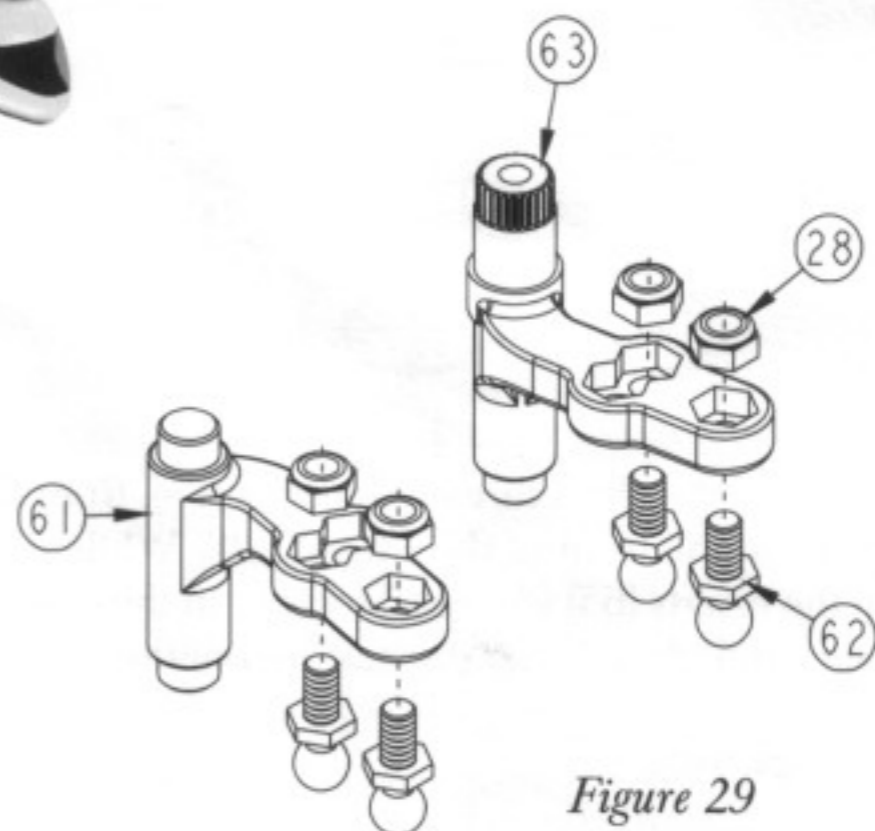


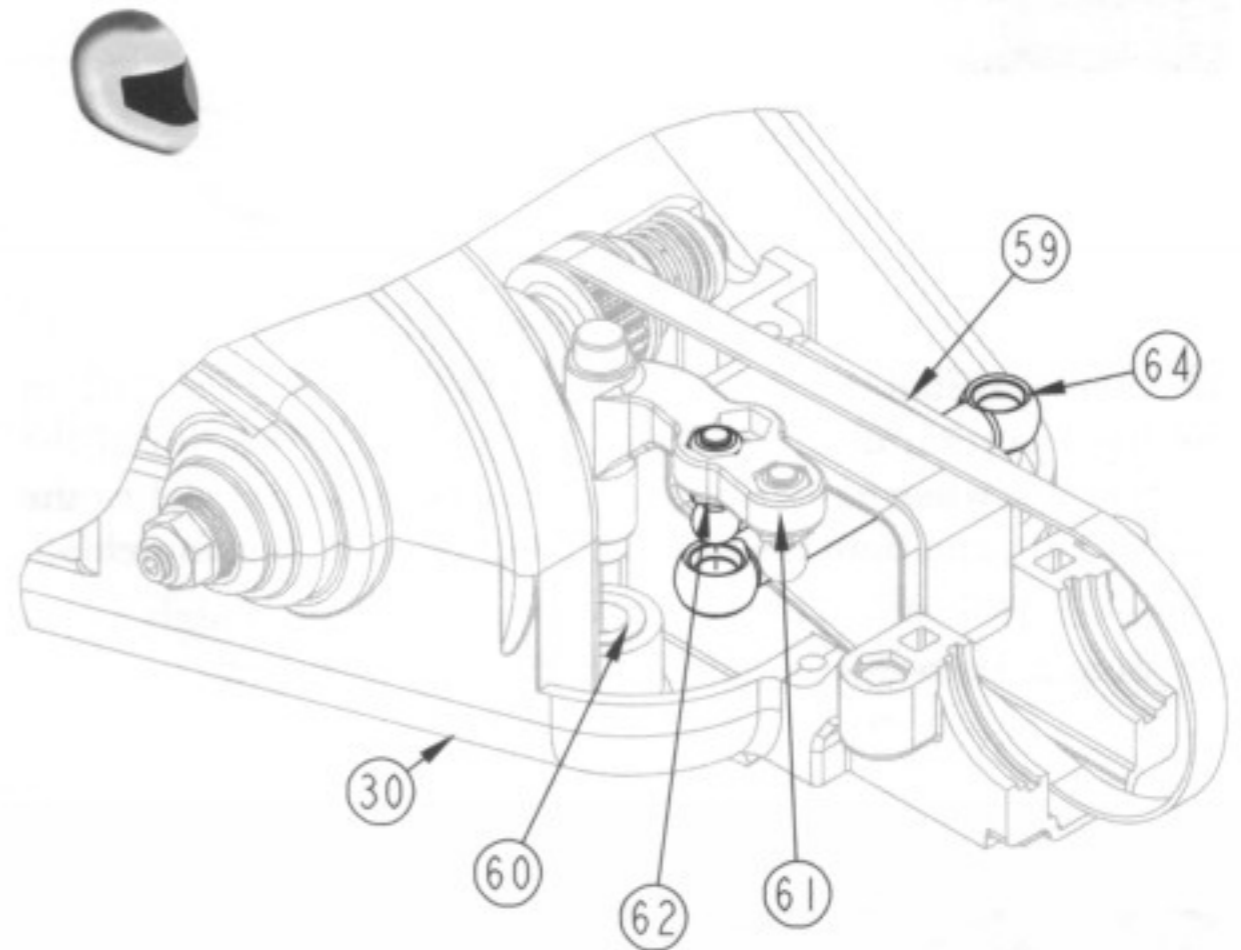
Figure 29

# BAG C (Continued)

**Figure 30**

❑ Step 6. Remove the steering drag link (64) from the tree of steering parts and attach it to the ball stud (62) in the idler arm (61) as shown. The drag link (64) should attach to the ball stud (62) toward the rear of the idler arm (61). This is the area of the idler arm (61) that has two holes.

❑ Step 7. Holding the idler arm (61) – with the drag link (64) attached – position the idler arm (61) so that the ball studs (62) point down. From the right side, slide the drag link (64) through the steering tunnel (59) and insert the bottom of the idler arm (61) in the steering bushing (60) on the right side of the chassis (30).



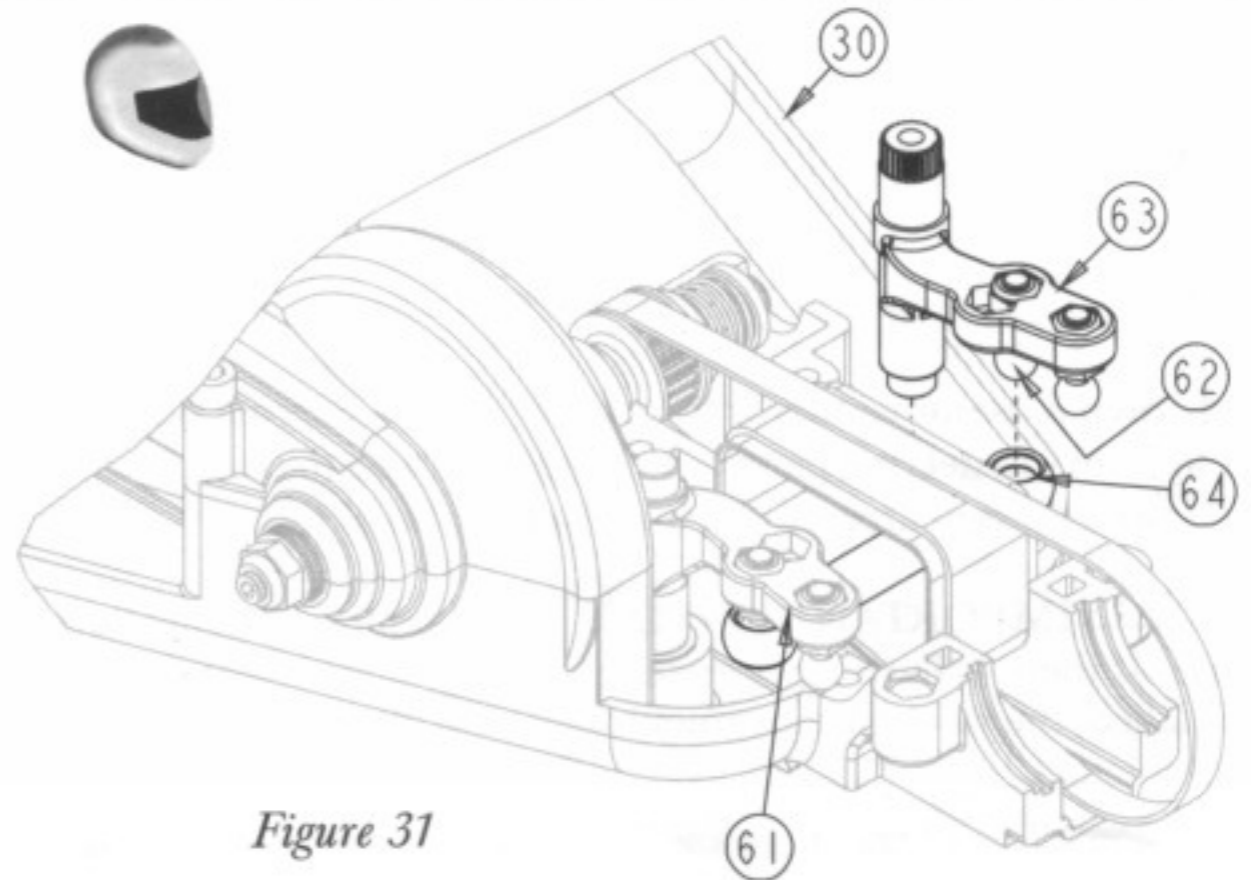
*Figure 30*

**Figure 31**

❑ Step 8. With the splined side of the steering bellcrank (63) pointing up, insert the bellcrank (63) in the steering bushing (60) on the left side of the chassis (30).

❑ Step 9. The rear ball studs (62) should be installed in the outside holes in both the steering bellcrank (63) and the idler arm (61). If they are not, move them to this location.

❑ Step 10. Attach the free end of the drag link (64) to the ball stud (62) in the steering bellcrank (63).

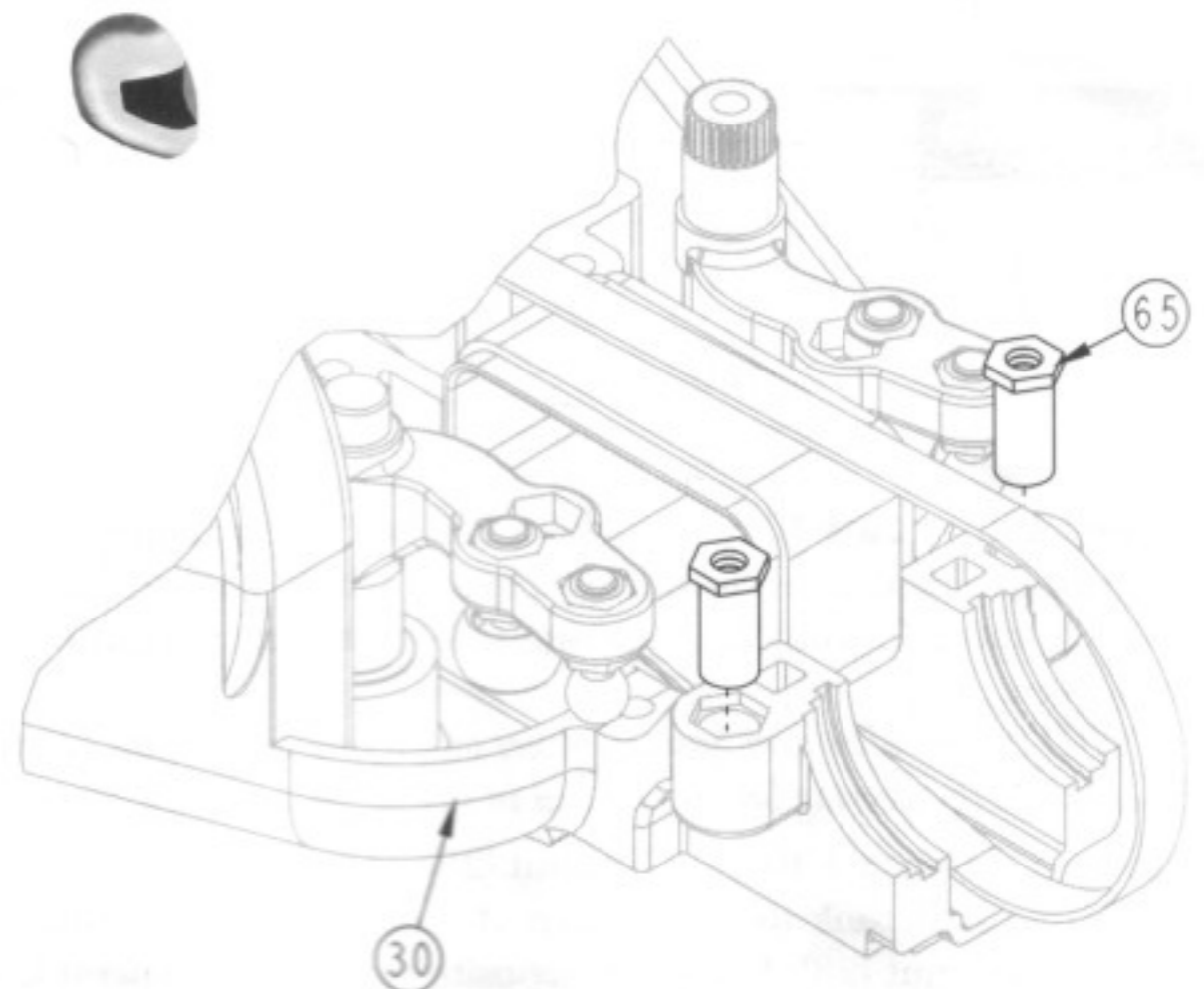


*Figure 31*

**Figure 32**



❑ Step 11. Install the short threaded inserts (65), from the top, in the two holes at the front of the chassis (30). While lining up the hexes on the inserts (65) with the hex area in the chassis (30), press the inserts (65) down, into the hex area of the chassis (30).



*Figure 32*

# BAG C (Continued)

**Figure 33**



- ❑ Step 12. Insert a 4-40 mini lock nut (28) into the hex area of the diff nut carrier (37). The thread-locking portion of the nut (28) should face the outside.

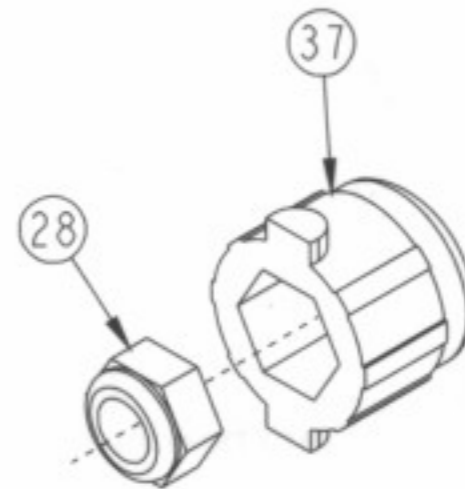


Figure 33

**Figure 34**



- ❑ Step 13. Locate the 5/64" Allen wrench (9) supplied with the kit. Place the diff nut carrier (37), nut side first, over the Allen wrench.
- ❑ Step 14. Stack the six 1/8" Belleville washers (22) over the wrench, next to the diff nut carrier (37). The washers (22) should all point the same direction and open away from the nut carrier (37) as shown in Figure 34A.

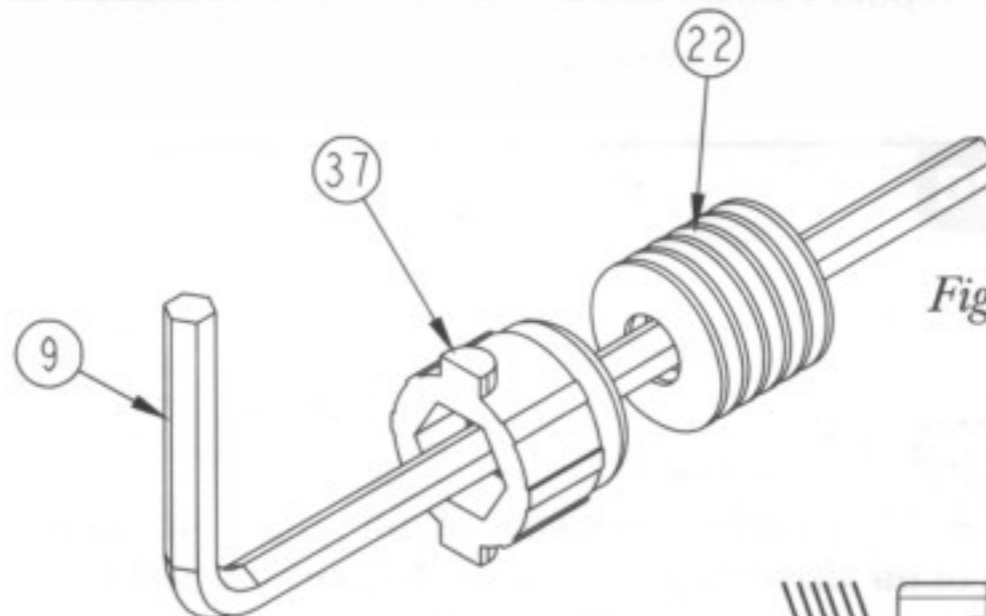


Figure 34



Belleville washers should face this direction

Figure 34A

**Figure 35**

- ❑ Step 15. Insert all of the parts that are stacked on the wrench into the right outdrive/diff half (66) (the one with the post). Line up the tabs on the diff nut carrier (37) with the slots in the outdrive (66). Press the parts all the way into the outdrive (66).

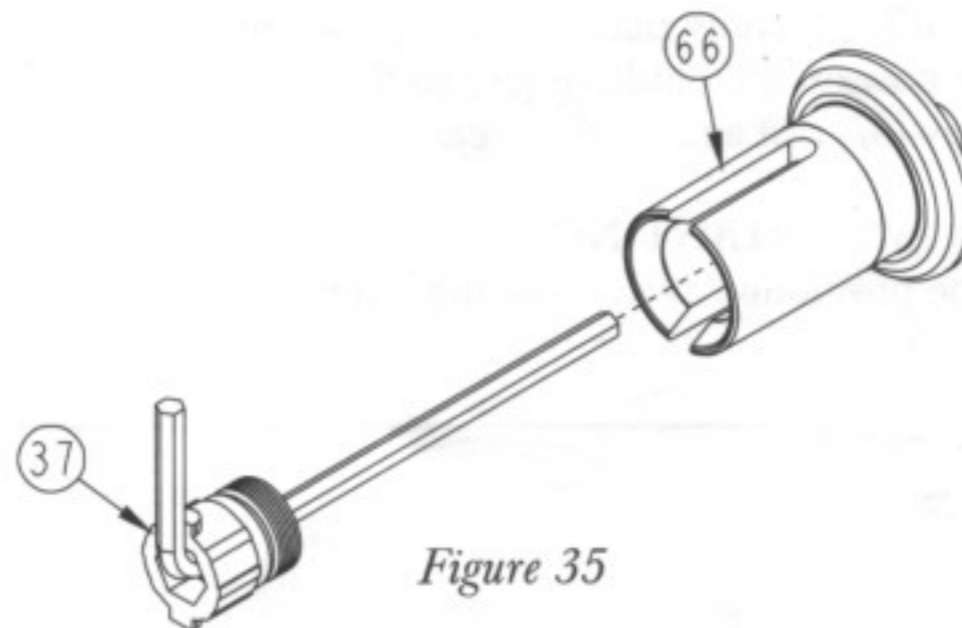


Figure 35

**Figure 36**



- ❑ Step 16. Apply a small amount of clear diff grease (40) to the outside ring of the right outdrive (66). Attach a diff drive ring (41) to the outdrive (66) by lining up the slot in the ring (41) with the slot in the outdrive (66).

*\*NOTE: Only a small amount of grease is needed. It is only there to hold the drive ring in place.*

**⚠ IMPORTANT NOTE:** Do not glue the drive rings to the outdrive/diff halves. Doing so may not allow the washers to mount flat.

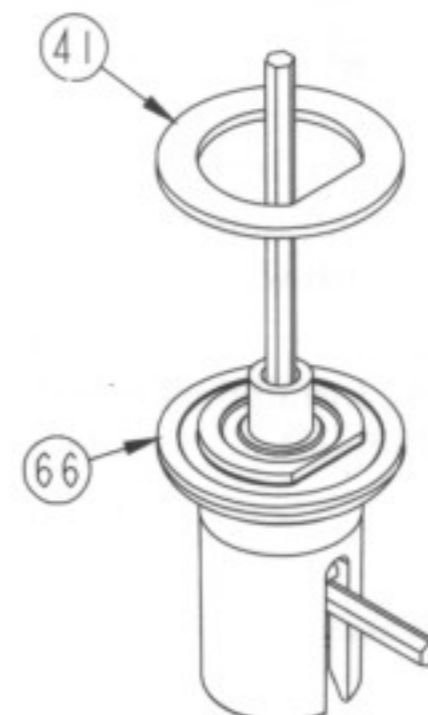


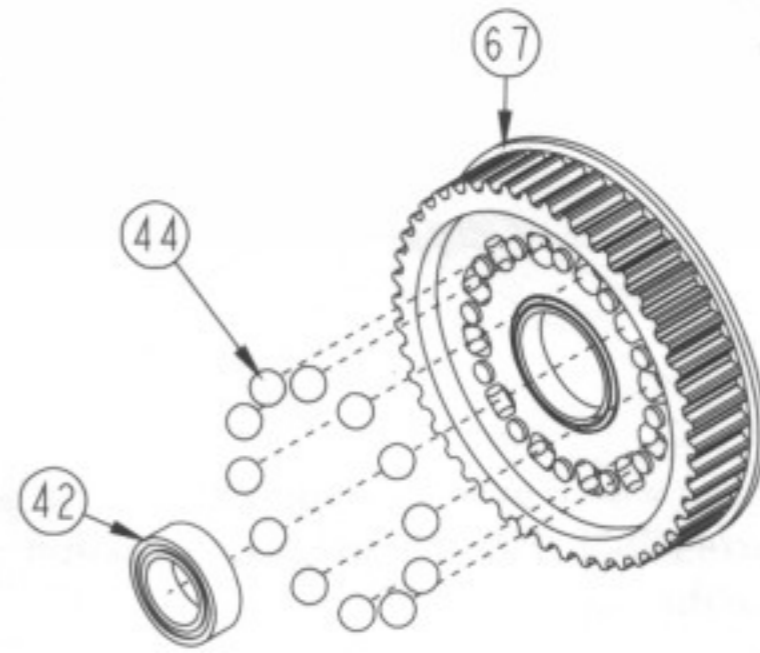
Figure 36

# BAG C (Continued)

**Figure 37**



- ❑ Step 17. Insert a 5mm x 8mm bearing (42) into the center of the front diff pulley (67).
- ❑ Step 18. Press a 3/32" diff ball (44) into each of the small holes in the diff pulley (67).



*Figure 37*

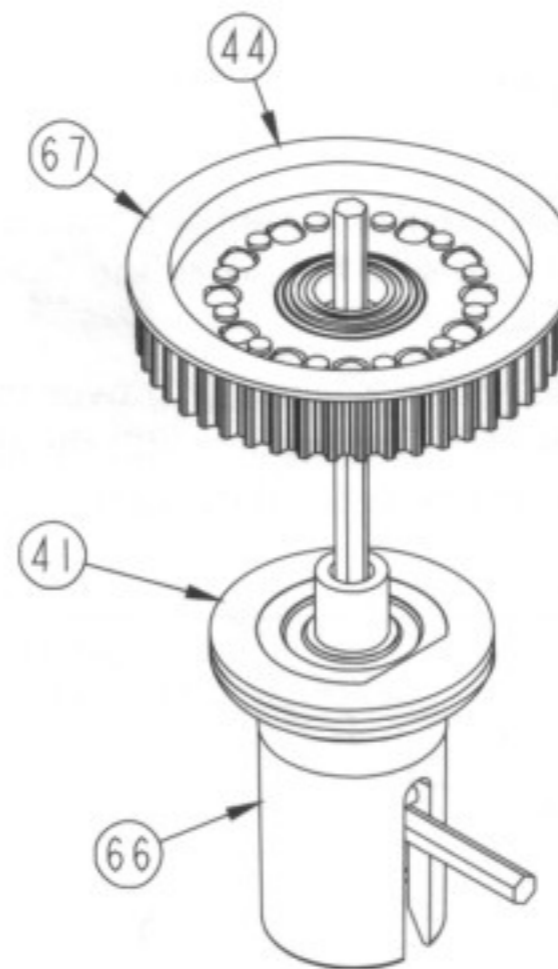
**Figure 38**

- ❑ Step 19. Apply a fairly heavy coat of diff grease (40) to the exposed side of the drive ring (41) that is already attached to the outdrive (66).

🔑 For best results, clean the drive rings with rubbing alcohol or motor spray before applying grease to the exposed side.

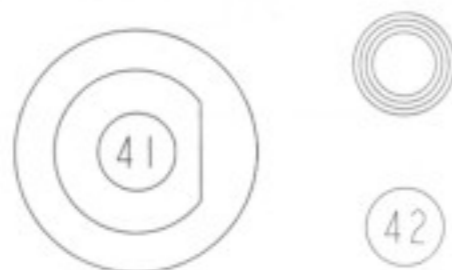
- ❑ Step 20. Carefully place the diff pulley (67), flange side up, over the post on the outdrive (66) so that the diff balls (44) and diff pulley (67) rest against the greased drive ring (41).

**⚠ IMPORTANT NOTE:** The flange on the diff pulley should be positioned away from the diff half.

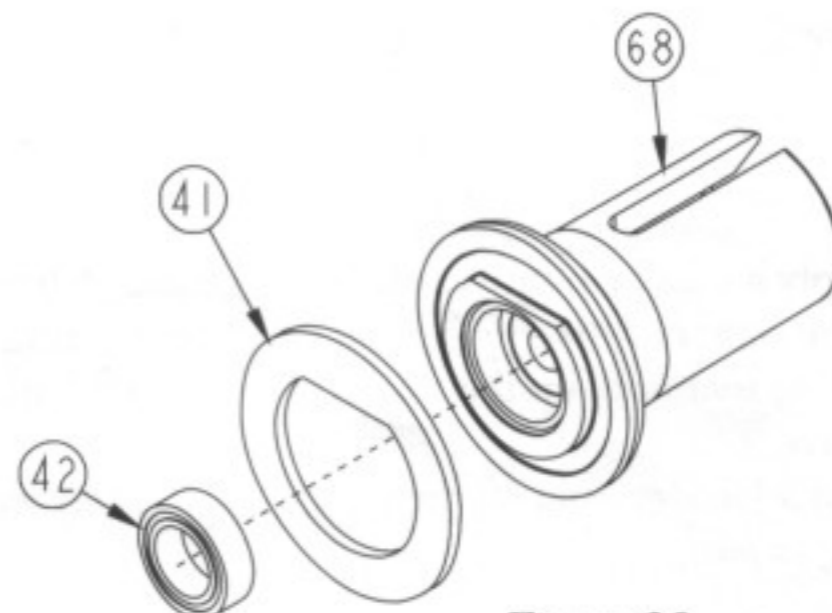


*Figure 38*

**Figure 39**



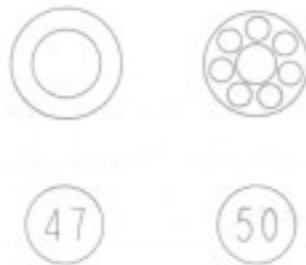
- ❑ Step 21. Press a 5mm x 8mm bearing (42) into the center area of the left plastic outdrive/diff half (68) as shown. The edge of the bearing (42) should be flush with the outdrive (68).
- ❑ Step 22. Apply a small amount of clear diff grease (40) to the outer ring of the outdrive (68). Install the second drive ring (41), again aligning the slots in the outdrive (68) and the drive ring (41).



*Figure 39*

# BAG C (Continued)

**Figure 40**



- ❑ Step 23. Place the foam thrust bearing seal (47) over the shoulder of the diff adjusting screw (46).
- ❑ Step 24. Place one of the 3mm x 8mm raced thrust bearing washers (48) over the diff screw (46) so that the groove in the washer (48) faces up.
- ❑ Step 25. Using the white thrust bearing/assembly grease (49), apply a fairly heavy coat of grease to the thrust washer (48) and place the 3mm x 8mm thrust bearing (50) over the screw (46), and next to the washer (48). Apply white thrust bearing/assembly grease (49) to the exposed side of the thrust bearing (50) and place the second thrust bearing washer (48) over the screw (46), against the thrust bearing (50). This time, the groove in the thrust washer (48) faces down.
- ❑ Step 26. Insert the diff screw (46), with the thrust bearing assembly installed, into the left plastic outdrive/diff half (68). Pull the threaded end of the diff screw (46) until the thrust bearing assembly rests against the inside of the outdrive (68).

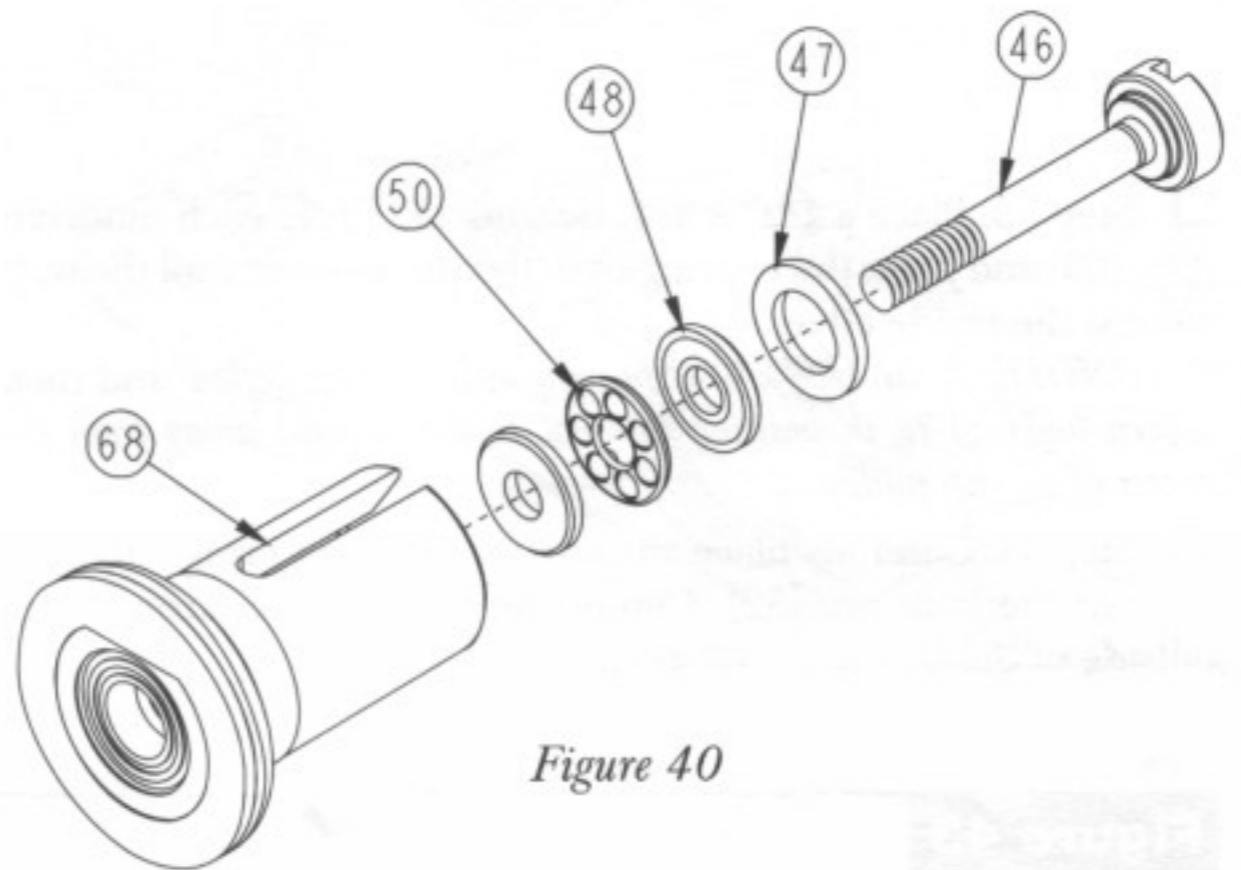


Figure 40

**Figure 41**

- ❑ Step 27. Locate the smallest of the supplied Allen wrenches (9) and place it in the slot in the outdrive (68) containing the diff screw (46). Slide the wrench all the way into the slot in the outdrive (68) against the screw (46). Handling the outdrive (68) with the wrench inserted, will hold the diff screw (46) in place while finishing assembly of the front diff.
- ❑ Step 28. Apply a fairly heavy coat of clear diff grease (40) to the exposed side of the drive ring (41).
- ❑ Step 29. While holding the left outdrive (68) with the Allen wrench inserted, carefully assemble it to the right outdrive/diff half (66).
- ❑ Step 30. Make sure that the slot in the diff screw (46) is lined up with the slot in the outdrive (68) and the Allen wrench is inserted in the diff screw (46).
- ❑ Step 31. Hold the diff so that the right outdrive (66) – with the diff nut carrier (37) – is pointing up. Slowly turn the right outdrive (66) clockwise to thread the diff screw (46) into the 4-40 mini nut (28) in the diff nut carrier (37). Thread the two outdrives together until the screw (46) just starts to snug up.

*\*NOTE: If the screw will not thread into the nut, make sure that the nut carrier is pushed all the way into the outdrive.*

🔑 When tightening the diff, tighten the screw a little and then “work” the diff a little. Then tighten the screw a little more and work the diff again. Continue this until the diff is tight. This will ensure that all the parts in the diff assembly are properly seated.

- ❑ Step 32. Tighten the diff until the pulley (67) cannot be turned while both of the outdrives (66), (68) are being held firmly. Final diff adjustment should be made after completion of the car.

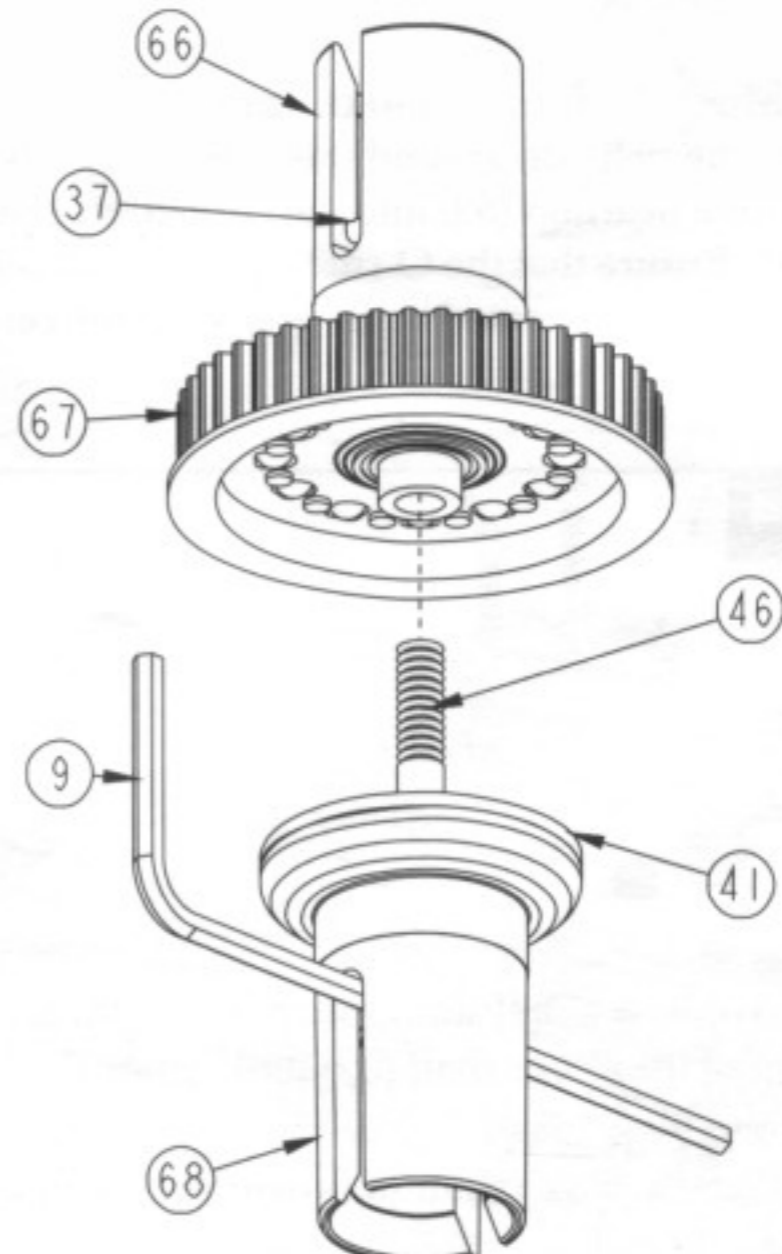
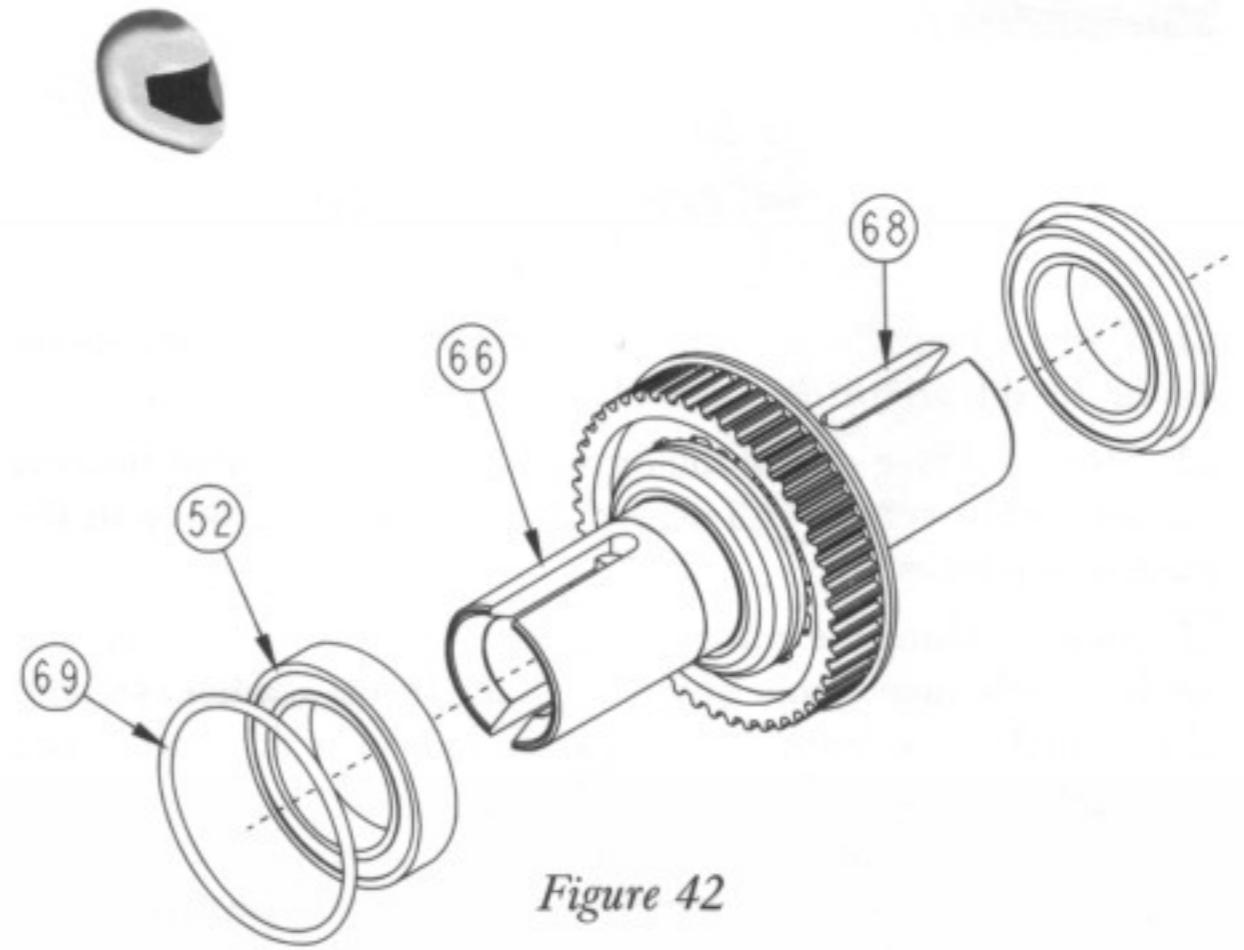
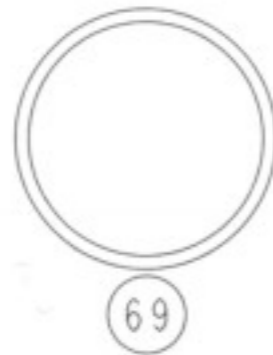


Figure 41

# BAG C (Continued)

**Figure 42**



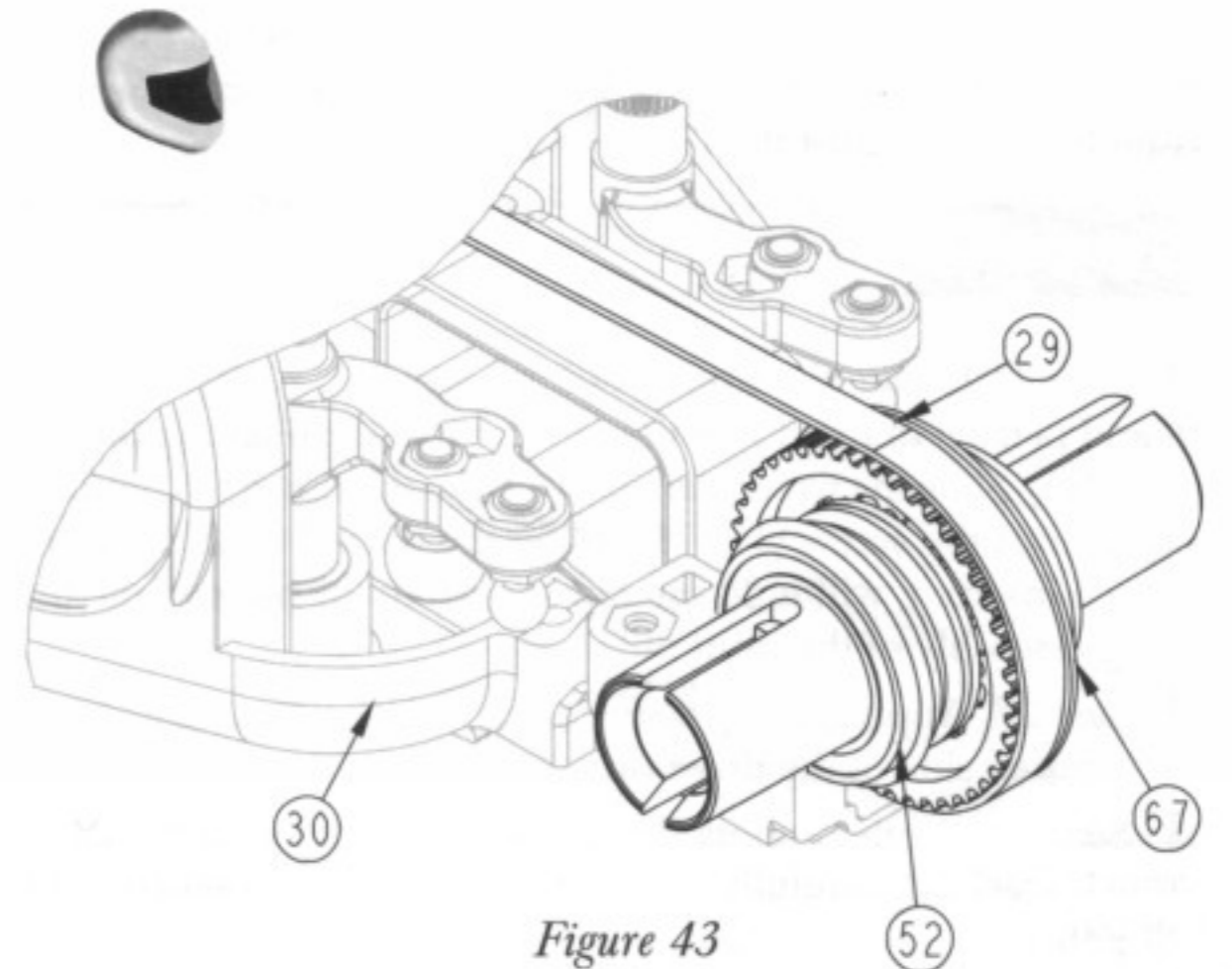
❑ Step 33. Place a 1/2" x 3/4" bearing (52) over each outdrive (66), (68) and press the bearing over the stepped area, all the way against the inside edge.

*\*NOTE: If the 1/2" x 3/4" bearing only has one Teflon™ seal (tan, woven looking) in it, position the seal to the outside, away from the center of the diff pulley.*

❑ Step 34. Carefully place an outdrive bearing O-ring (69) over each of the bearings (52). Center the O-rings (69) around the outside of the bearings (52) as shown.

Figure 42

**Figure 43**



❑ Step 35. With the flange on the front diff pulley (67) to the left side of the chassis (30), position the front diff in the center of the front belt (29).

❑ Step 36. Move the front diff to the front edge of the chassis (30), wrapping the belt (29) around the pulley (67) as you do so. Place the outdrive bearings (52) into the curved, recessed area of the chassis (30). Ensure that the O-rings (69) are still centered on the bearings (52) and are seated in the groove in the center of the recessed area.

Figure 43

**Figure 44**



❑ Step 37. Apply a small amount of white thrust bearing/assembly grease (49) to the shaft (32) and center the belt roller (31) on the shaft (32).

❑ Step 38. Place a 3/32" shim (33) over each end of the belt roller shaft (32).

❑ Step 39. Make two of these belt roller assemblies.

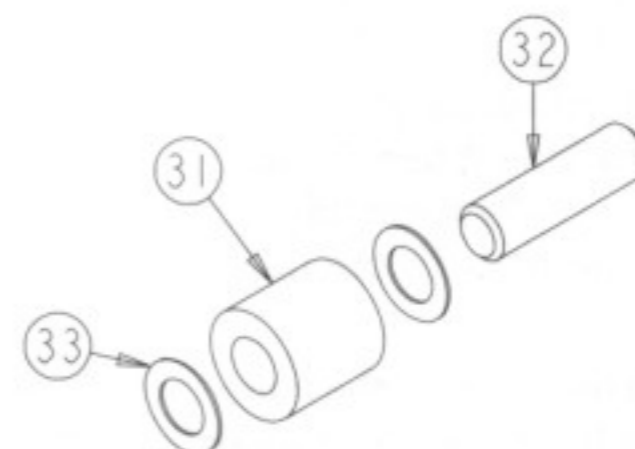


Figure 44

# BAG C (Continued)

## Figure 45

❑ Step 40. Carefully pick up one of the belt roller assemblies using a pair of tweezers or small needle-nose pliers. Hold the assembly by the shims (33) on either end as shown. Position the assembly above the area for the shaft (32) in the rear of the front belt cover (70).

🔑 If a small amount of white assembly grease is applied to the cover, in the area for the shaft prior to installation, the roller shaft will be held in place better – making installation easier.

❑ Step 41. Once the assembly is in position, press the shaft (32) into place.

*\*NOTE: Be careful not to bend or damage the shims. The roller should rotate freely once in position.*

❑ Step 42. Repeat steps 40 and 41 for the second belt roller assembly. This time the roller assembly is mounted in the front of the belt cover (70).

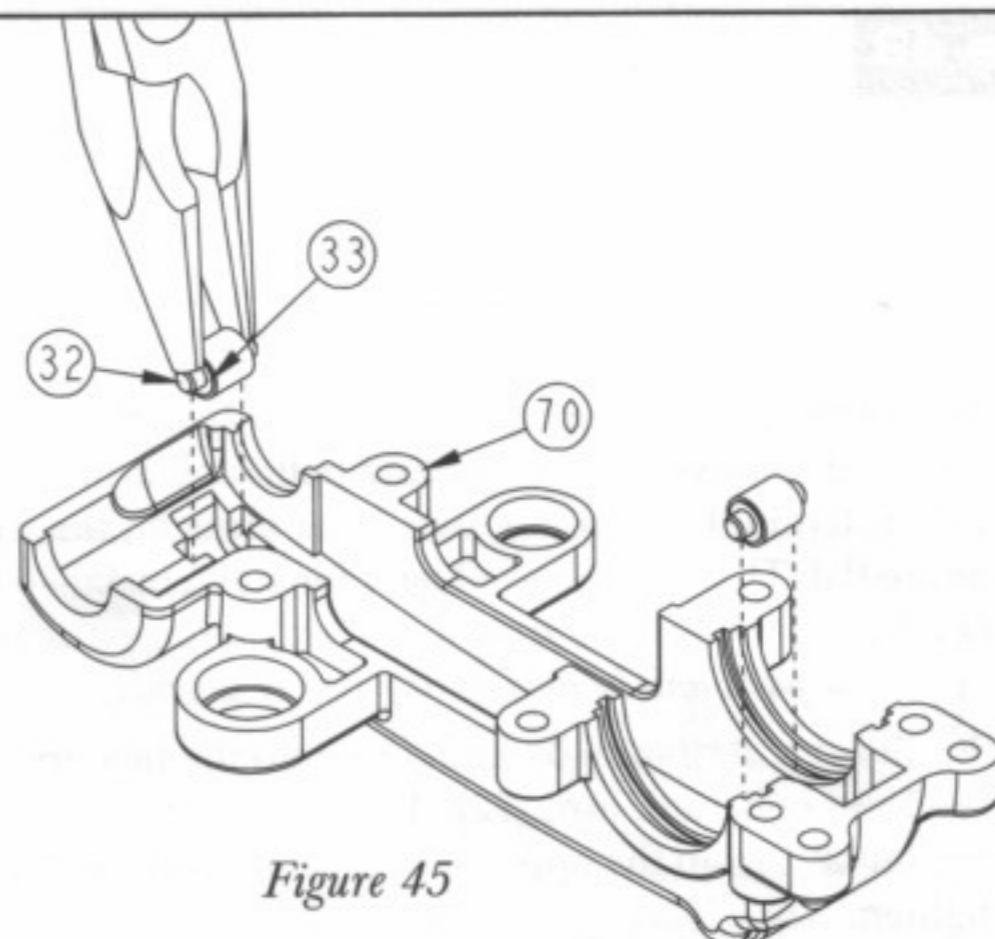


Figure 45

## Figure 46



❑ Step 43. Remove the remaining 3/16" x 5/16" plastic steering bushing (60) from the steering parts tree. Press a bushing (60) into the recessed area in the front belt cover (70). This bushing goes in the area that does not have a hole all the way through the cover (70).

❑ Step 44. Remove the 1/4" x 3/8" plastic steering bushing (71) from the steering parts tree. Press the bushing (71) into the recessed area around the hole that passes all the way through the cover (70).

**⚠ IMPORTANT NOTE:** Trim all flashing off of the bushings. If there is flashing present on the bushings when they are installed, the steering movement may be tight when assembly is complete.

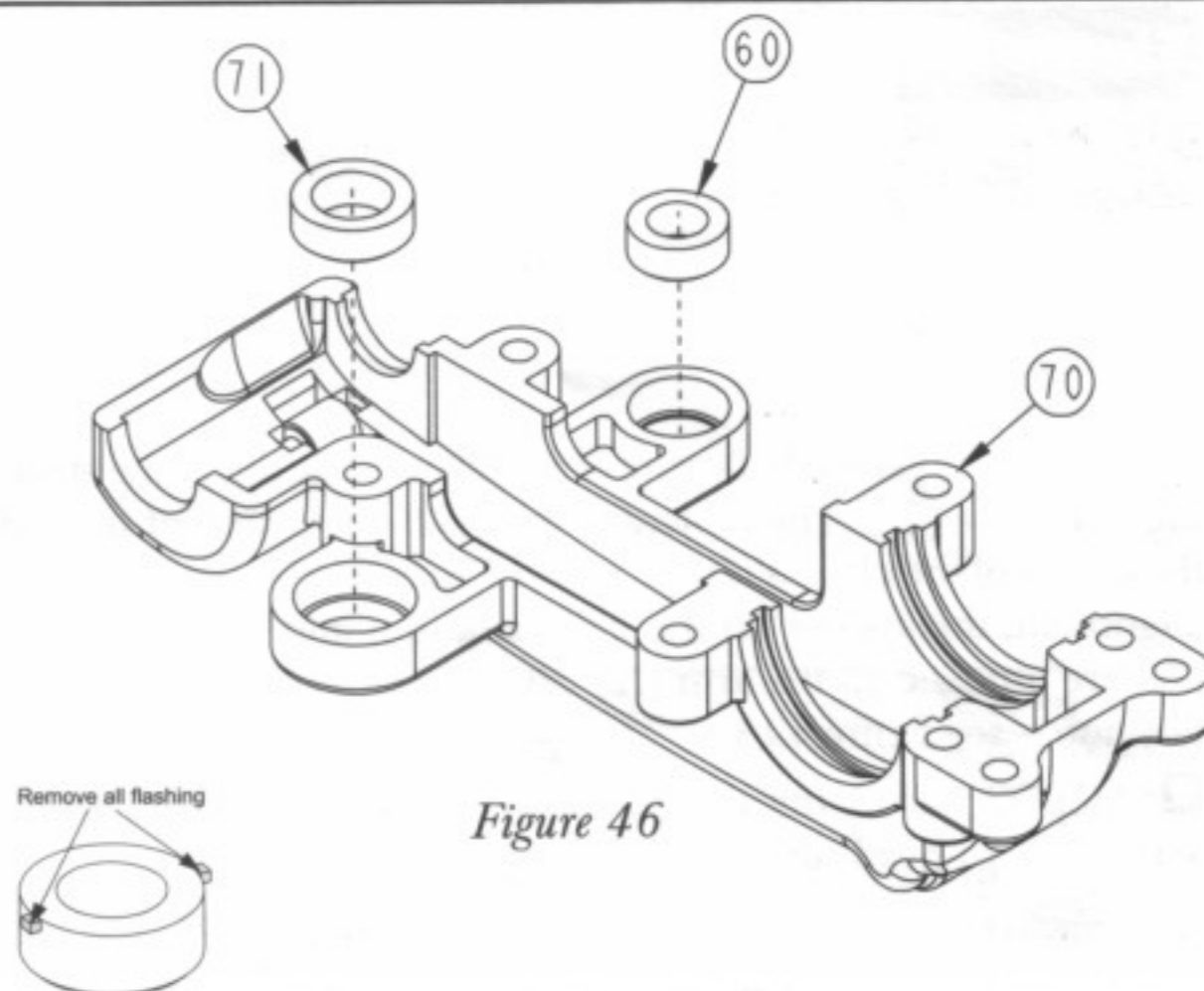


Figure 46

## Figure 47



(57)

❑ Step 45. Ensure that the hexes of the two threaded inserts (65) are still in the hex areas at the front of the chassis (30).

❑ Step 46. Attach the front belt cover (70) – with belt rollers and steering bushings installed – to the front of the chassis (30). Carefully align the tops of the steering bellcrank (63) and steering idler arm (61) so that they fit into the bushings (60), (71).

❑ Step 47. Press the cover (70) all the way down, into position. Check to be sure that the outdrive bearing O-rings (69) are in the center groove of the cover (70), and not pinched between the chassis (30) and the cover (70).

❑ Step 48. Secure the cover (70) to the chassis (30) with two 4-40 x 5/8" cap-head screws (57). Thread the screws (57) through the two rear holes in the cover (70), into the chassis (30), and tighten.

*\*NOTE: Apply a small amount of the white assembly grease to the threads of the screws.*

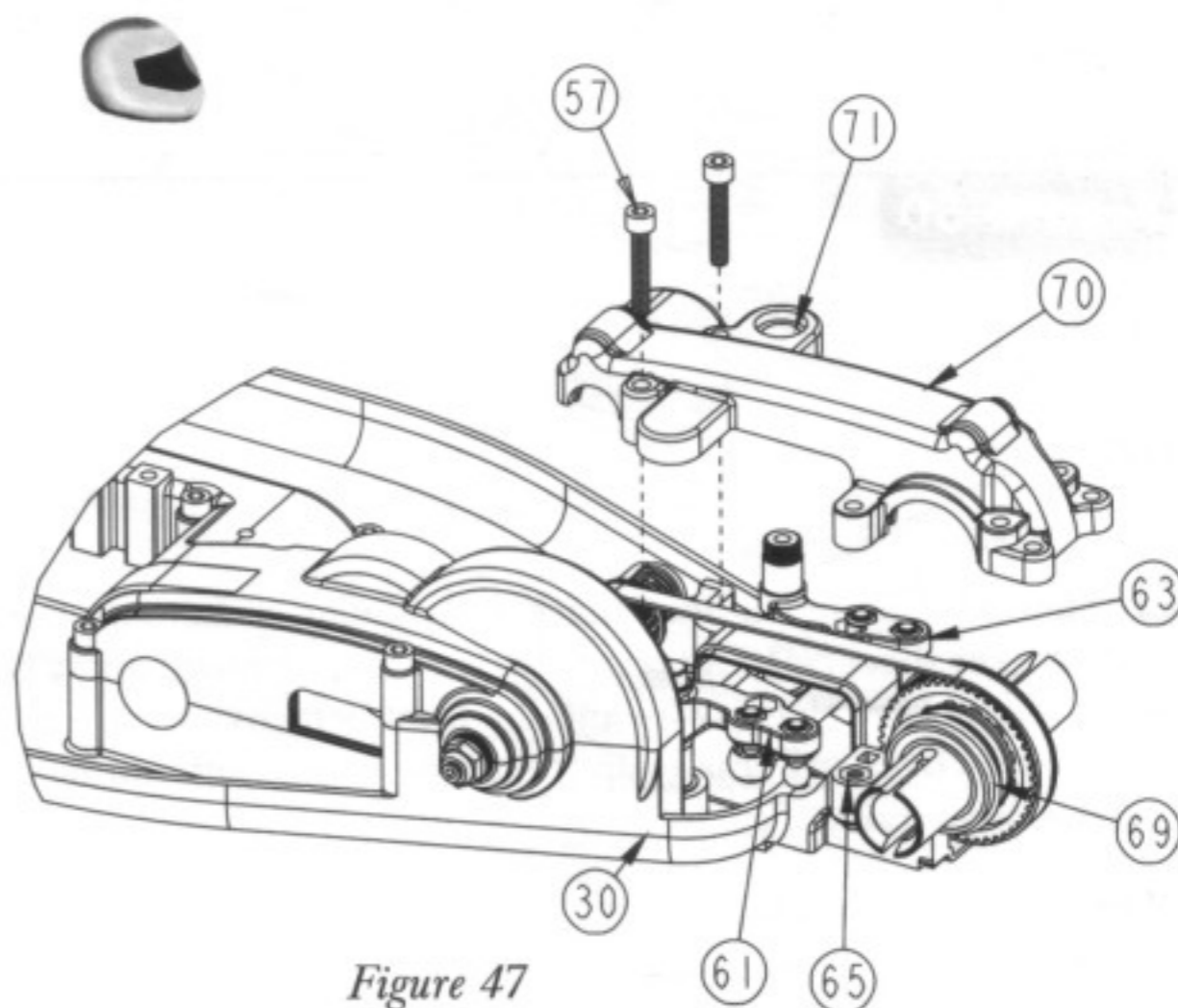


Figure 47

# BAG C (Continued)

**Figure 48**



❑ Step 49. Locate the steering bellcrank arm (72) on the tree of steering parts and remove it. The steering bellcrank arm (72) is the arm with a step in it. There are two other arms on the tree. These arms are flat. They will be used later for servo installation.

*\*NOTE: Set the tree with the remaining three steering parts on it aside for now. These parts will be used during Bag H assembly.*

❑ Step 50. Insert a 4-40 mini locknut (28) into the hex area to the outside of the bellcrank arm (72). Thread a 3/16" ball stud (62) into the nut (28), from the opposite side of the bellcrank arm (72), and tighten.

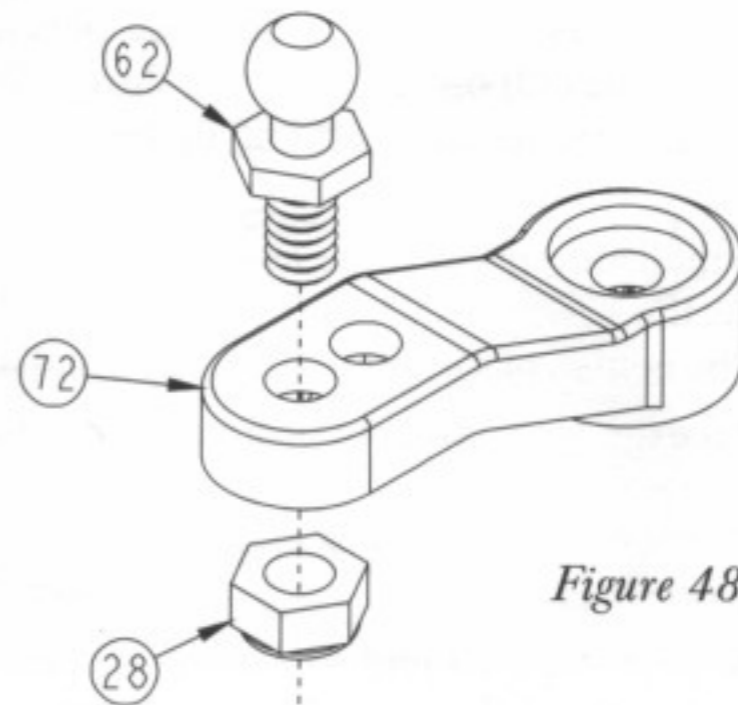


Figure 48

**Figure 49**



❑ Step 51. Press the bellcrank arm (72) onto the top of the steering bellcrank (63). The bellcrank arm (72) should point toward the center of the chassis (30) as shown. To ensure proper steering alignment, the splines on the bellcrank (63) and bellcrank arm (72) are indexed so the arm (72) can only be pressed on in one position – see figure 49A.

❑ Step 52. Secure the arm (72) to the bellcrank (63) with a 4-40 x 1/4" button-head screw (73).

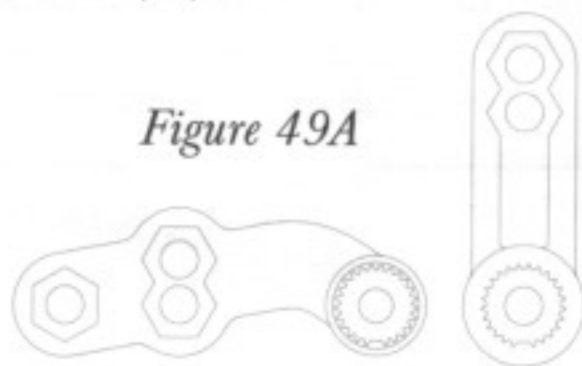


Figure 49A

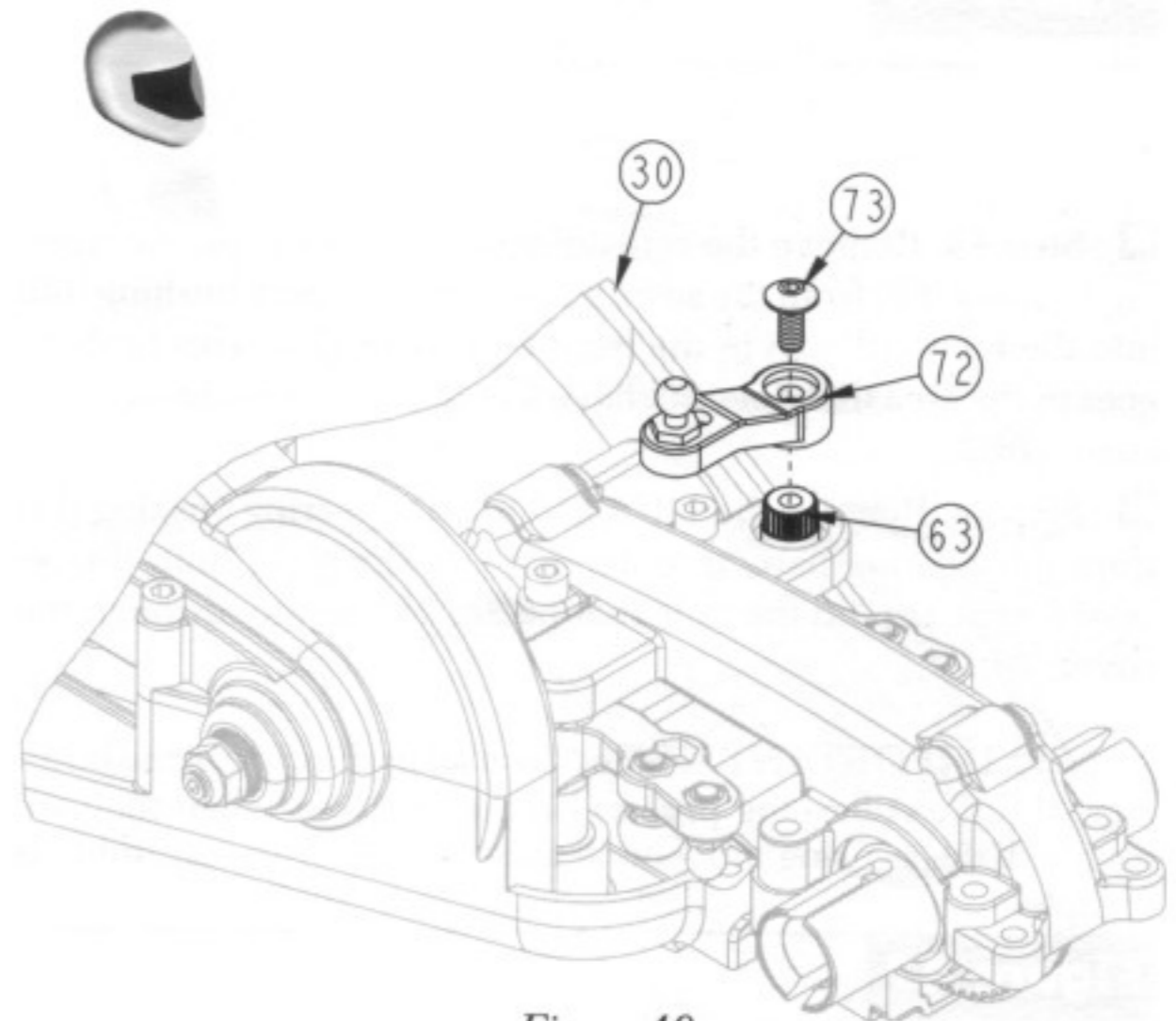


Figure 49

**Figure 50**

❑ Step 53. Locate the four black rectangular stickers on the XX-4 sticker sheet (74). Cut one of these stickers out and apply it to the seam of the chassis (30) and the front belt cover (70). The sticker will cover any small gaps that may be present and help seal the drive train.

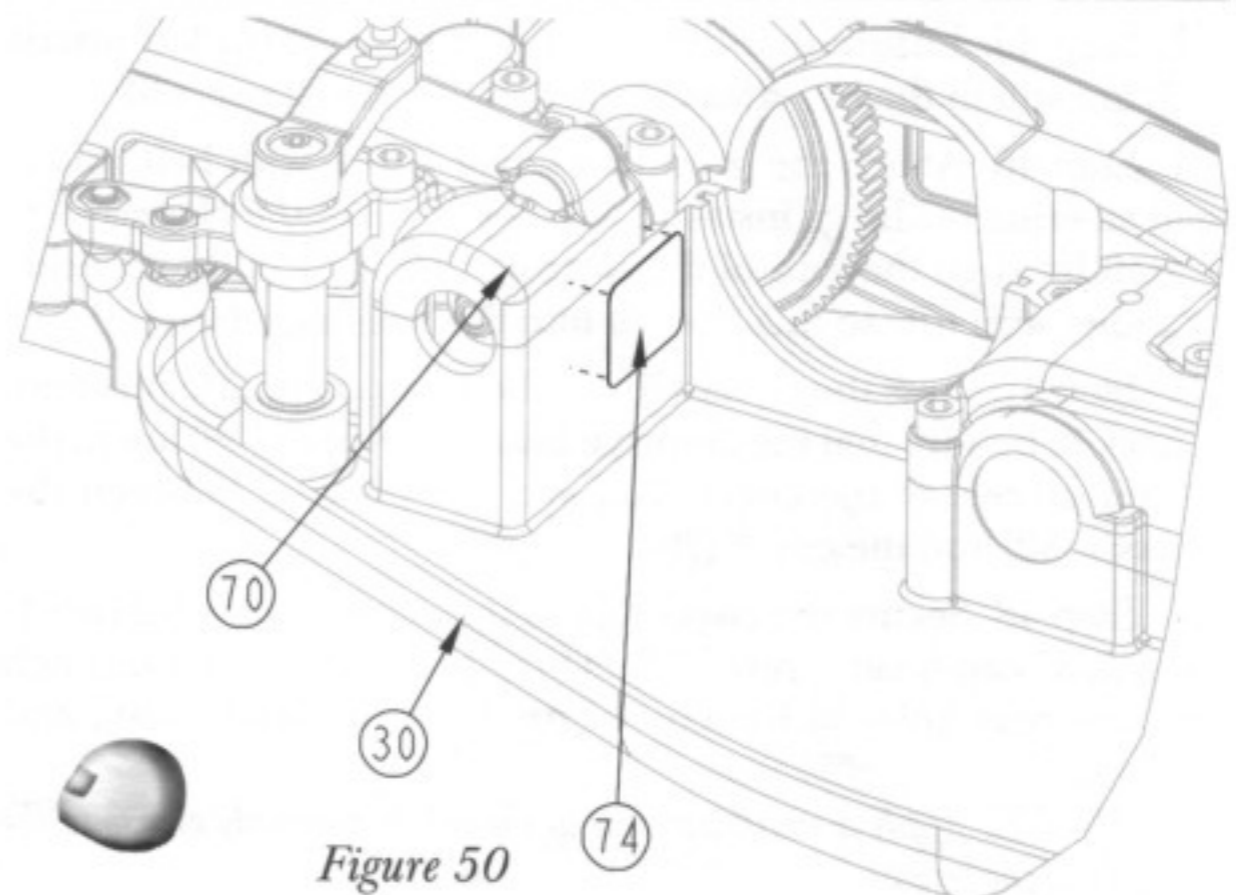


Figure 50

# BAG D

**Figure 51**



❑ Step 1. Place a 1/8" stainless washer (75) in the recessed area at the rear of the front bulkhead (76).

❑ Step 2. Position a front suspension arm (77) over the right side of the front bulkhead (76). Line up the holes in the arm (77) with the holes in the bulkhead (76) and attach them by inserting an inner front hinge pin (78) all the way through both parts until the pin (78) extends evenly out both sides of the suspension arm (77).

**⚠ IMPORTANT NOTE:** Make sure that the front suspension arm is attached correctly. The shock mounting holes should be facing forward as shown.

❑ Step 3. Secure the hinge pin (78) with two 1/8" E-clips (79). Ensure that the hinge pin (78) is centered, and the E-clips (79) are not rubbing the suspension arm (77).

❑ Step 4. Thread a 5-40 x 1/8" set screw (80) into the hole in the bottom of the front bulkhead (76), near the front, next to the hinge pin (77).

*\*NOTE: The set screw will hold the pin in place should the E-clips come off while running. The set screw needs to be removed in order to remove the front hinge pin.*

❑ Step 5. Repeat steps 1-4 for the left side.

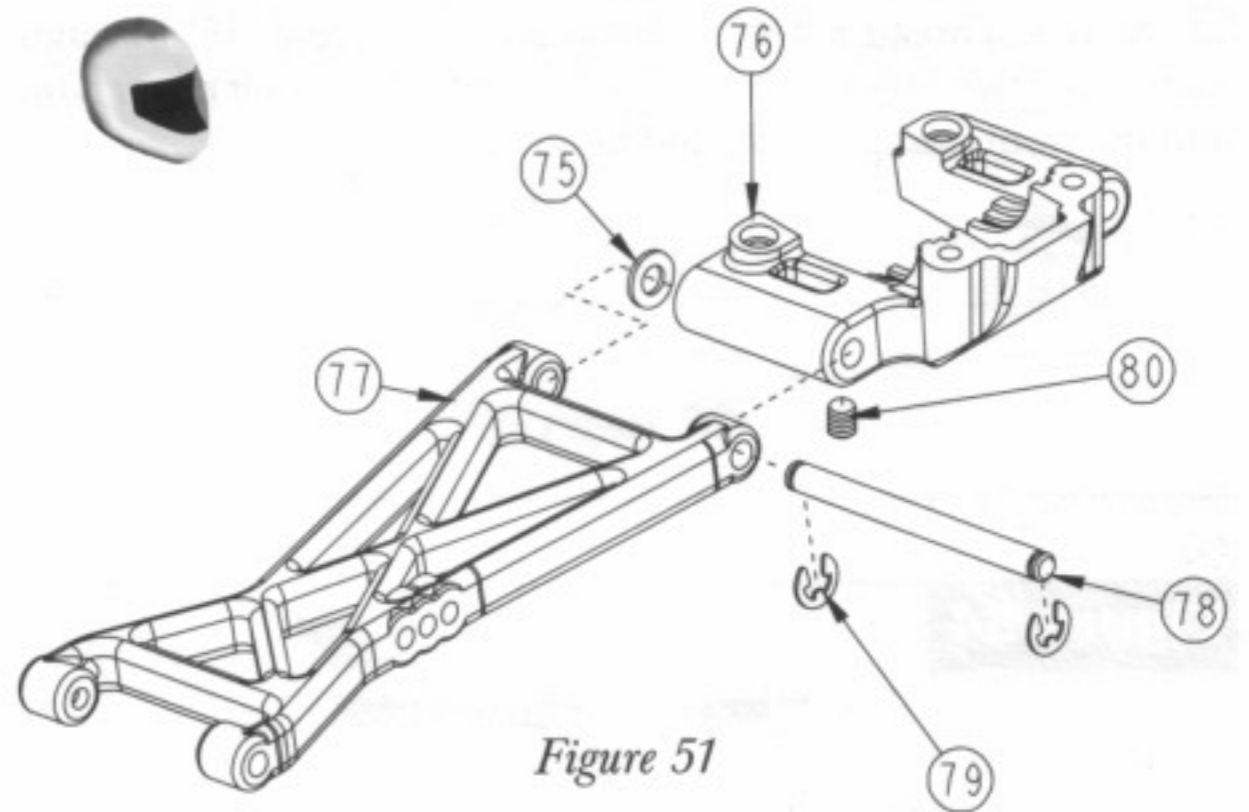
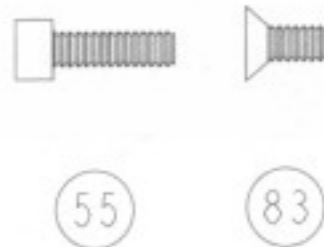


Figure 51

**Figure 52**



❑ Step 6. Ensure that the O-rings (69) are still centered on the outdrive bearings (52) and attach the front bulkhead (76) to the bottom of the chassis (30).

*\*NOTE: The suspension arms should be swung all the way down. If they arms are in the upward position, they may interfere with the outdrives, keeping the bulkhead from being correctly positioned.*

❑ Step 7. Thread a 4-40 x 3/8" cap-head screw (55) through each of the two holes in the rear of the bulkhead (76) and into the threaded inserts (65).

❑ Step 8. Attach the front bumper (81) to the bottom of the chassis, aligning the holes in the center of the bumper (81) with the heads of the screws (55). Secure the bumper (81) by threading a 4-40 x 1/4" flat-head screw (83) through each of the two holes in the back of the bumper (81), and into the chassis (30).

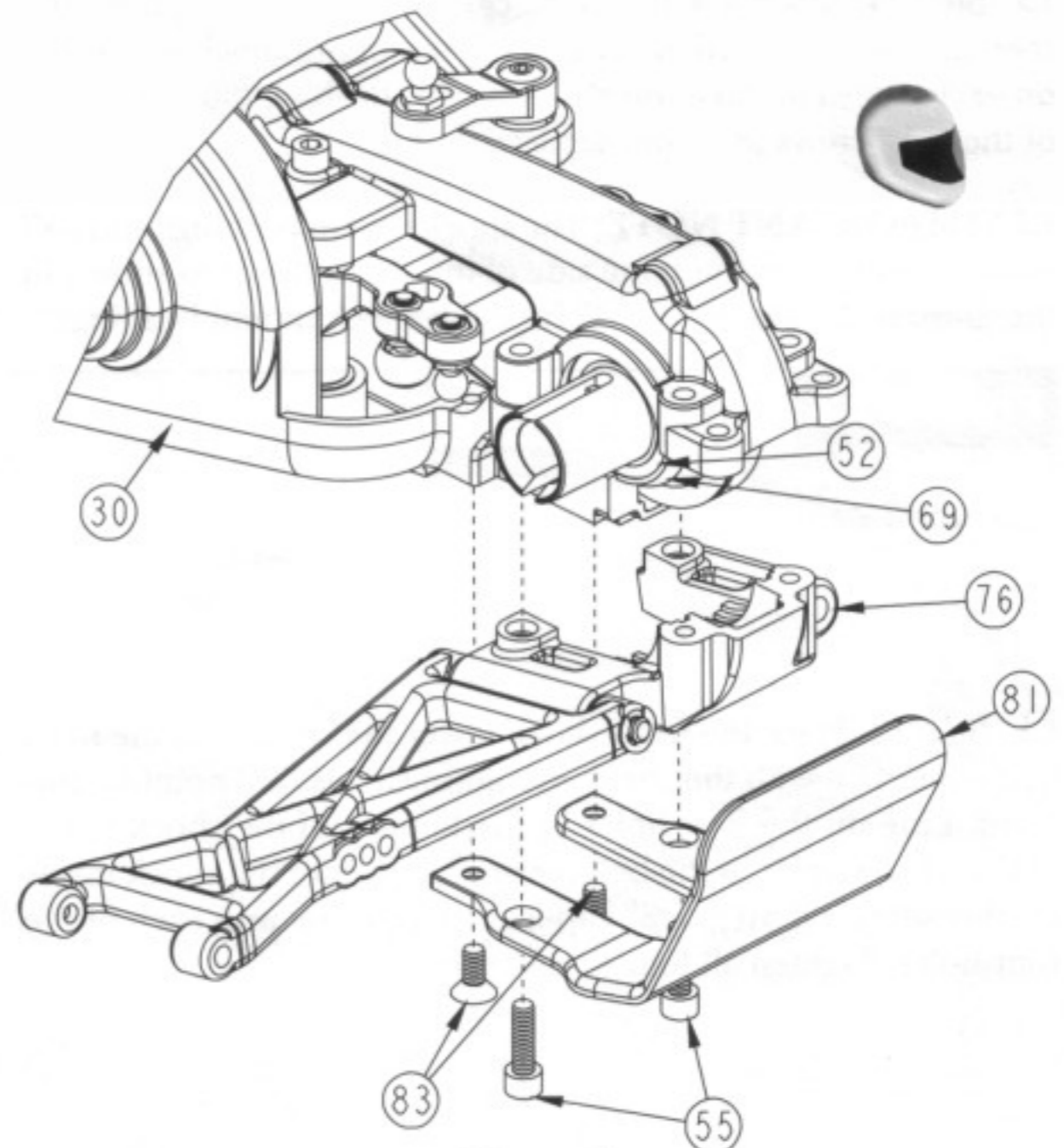


Figure 52

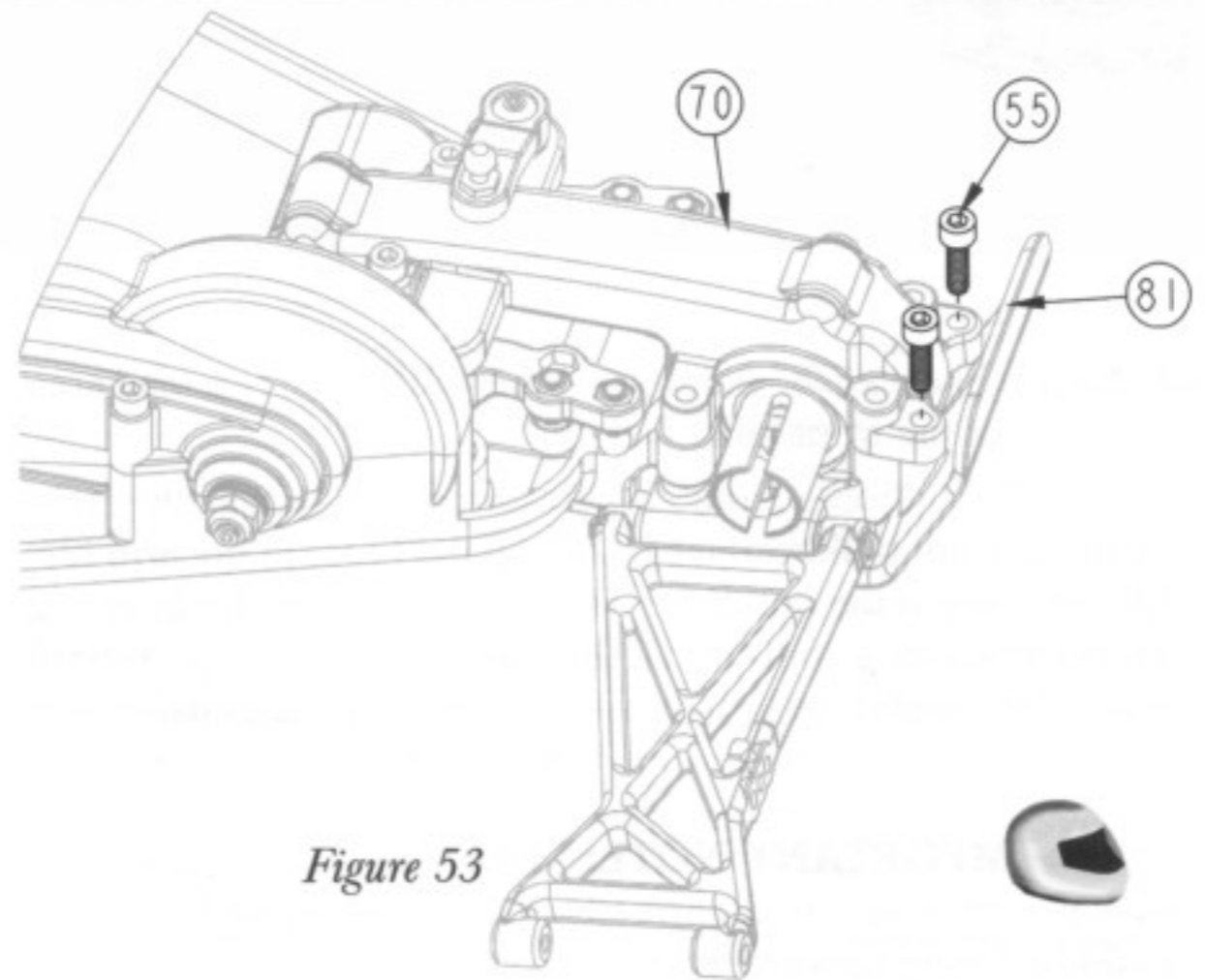
# BAG D (Continued)

**Figure 53**



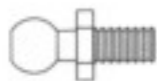
(55)

❑ Step 9. Thread a 4-40 x 3/8" cap-head screw (55) through each of the two holes at the very front of the front belt cover (70), into the front bumper (81), and tighten.



*Figure 53*

**Figure 54**



(62)

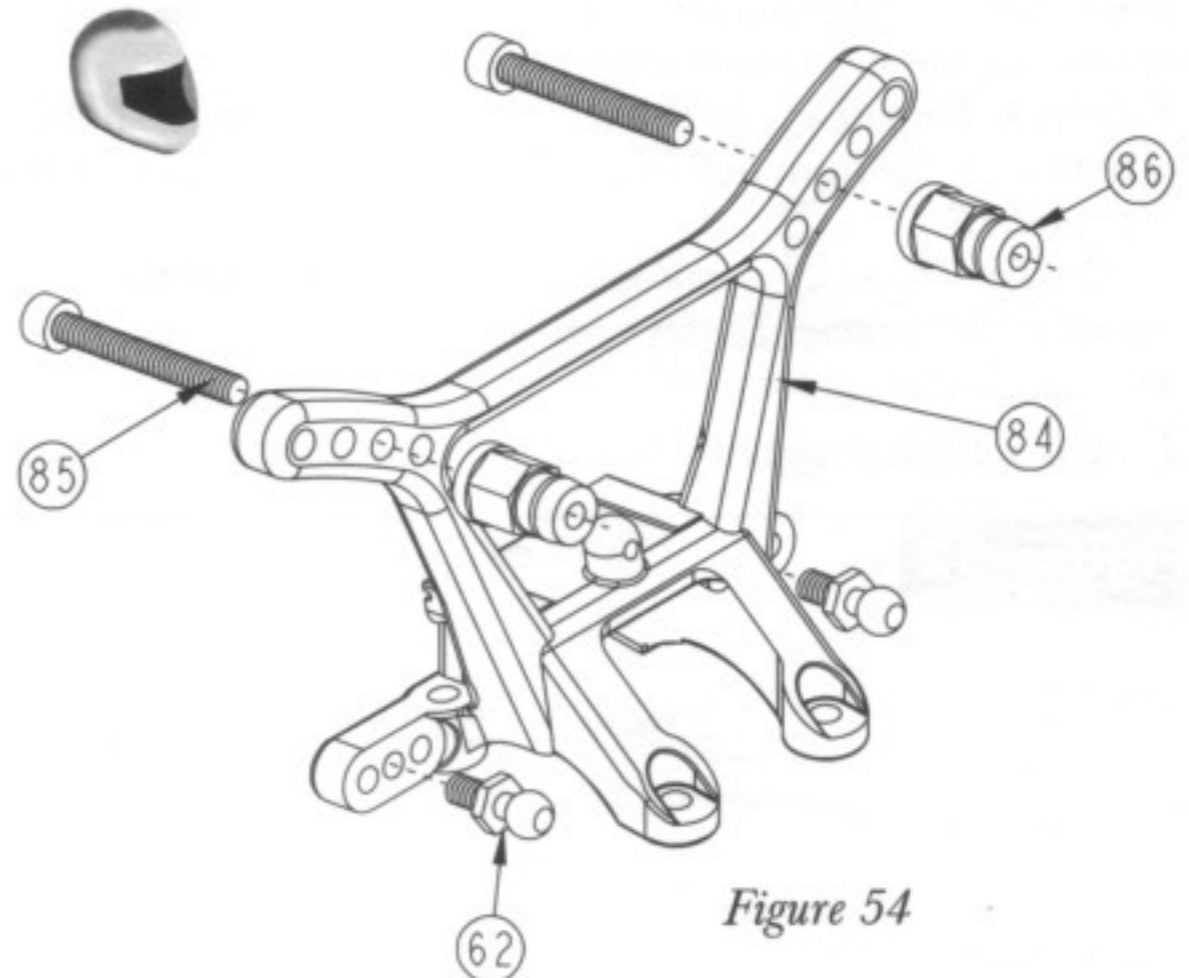


(85)

❑ Step 10. Thread a 3/16" ball stud (62) into each of the middle holes on the bottom of the front shock tower (84). Mount the ball studs (62) from the front as shown.

❑ Step 11. Insert a 4-40 x 7/8" cap-head screw (85), from the rear, through the third hole in on the top of the shock tower (84) on each side. Thread a top shock mount bushing (86) onto each of the two screws (85), and tighten.

**⚠ IMPORTANT NOTE:** The shock mount bushings and ball studs should be on the same side of the shock tower as shown in the illustration. Do not overtighten the shock mount bushings.



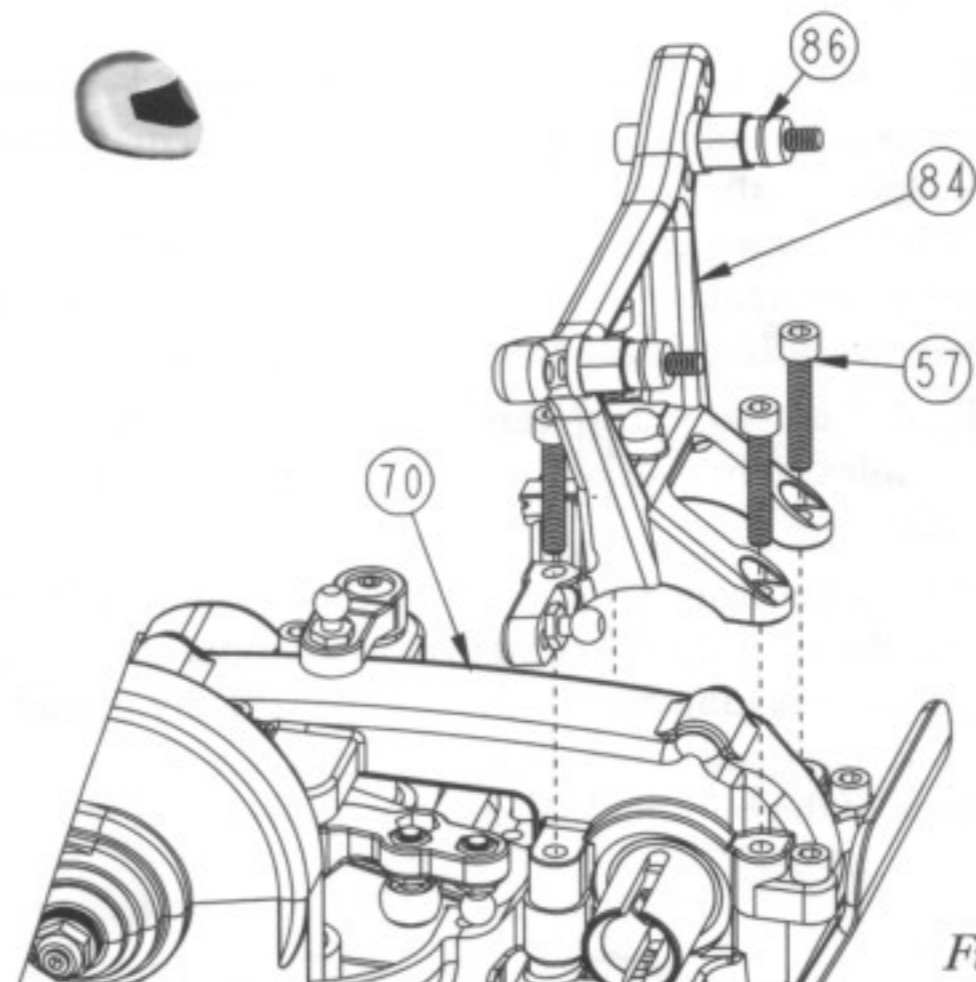
*Figure 54*

**Figure 55**



(57)

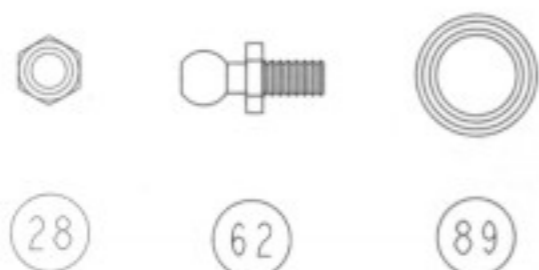
❑ Step 12. Place the front shock tower (84) on top of the front belt cover (70) with the shock mount bushings (86) pointing forward. Line up the four holes in the bottom of the shock tower (84) with the holes in the belt cover (70). Secure the shock tower by threading a 4-40 x 5/8" cap-head screw (57) into each of the four holes. Tighten all four screws (57).



*Figure 55*

# BAG D (Continued)

**Figure 56**



❑ Step 13. Insert a 4-40 mini locknut (28) into the hex area in the bottom of the right spindle (88). Thread a 3/16" ball stud (62) into the nut (28), from the opposite side of the spindle arm, and tighten.

❑ Step 14. Install a 1/4" x 3/8" bearing (89) in each side of the spindle (88).

*\*NOTE: If the bearings only have one Teflon™ seal (tan, woven looking) in them, position the Teflon™ seal to the outside.*

❑ Step 15. Repeat steps 13 and 14 for the left spindle (87).

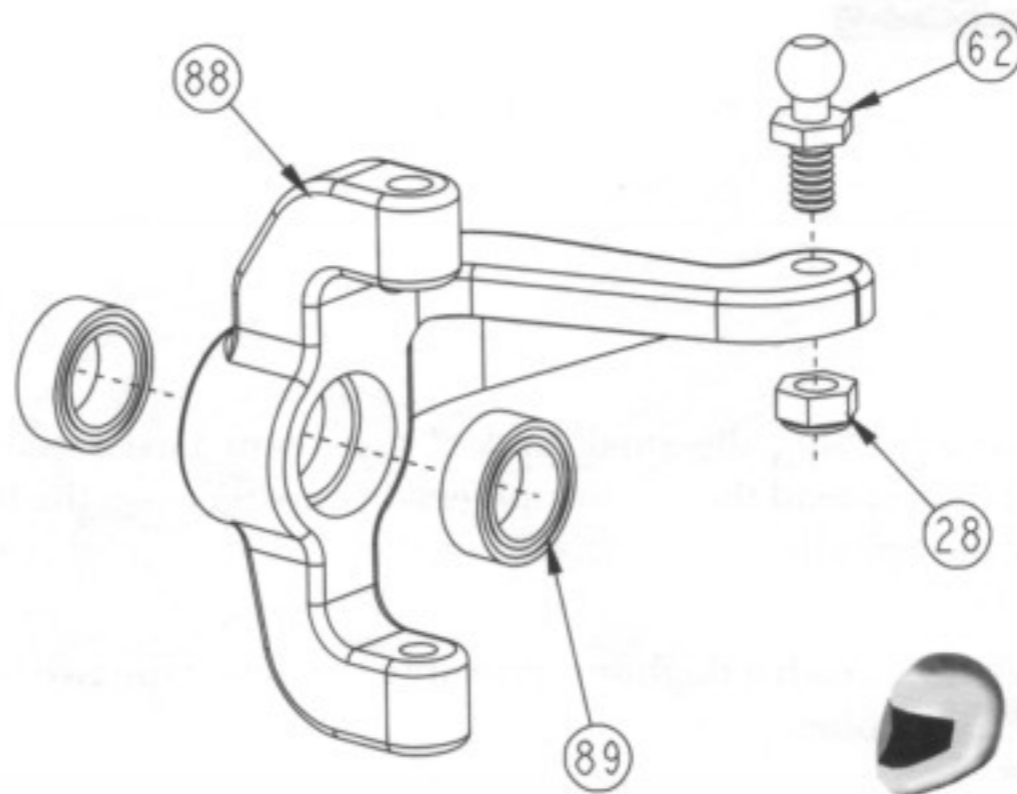


Figure 56

**Figure 57**



❑ Step 16. Insert a front stub axle (90) into the bearings (89) in the right spindle (88), from the outside as shown.

❑ Step 17. Lining up the slot on the axle (90) with the slot in the front universal yoke (91), attach the universal yoke (91) to the back of the stub axle (90) by pressing the yoke (91) through the bearing (89) on the back side of the spindle (88). Secure the yoke (91) to the axle (90) with a 2-56 x 1/4" cap-head screw (92).

❑ Step 18. Repeat steps 16 and 17 for the left spindle (87).

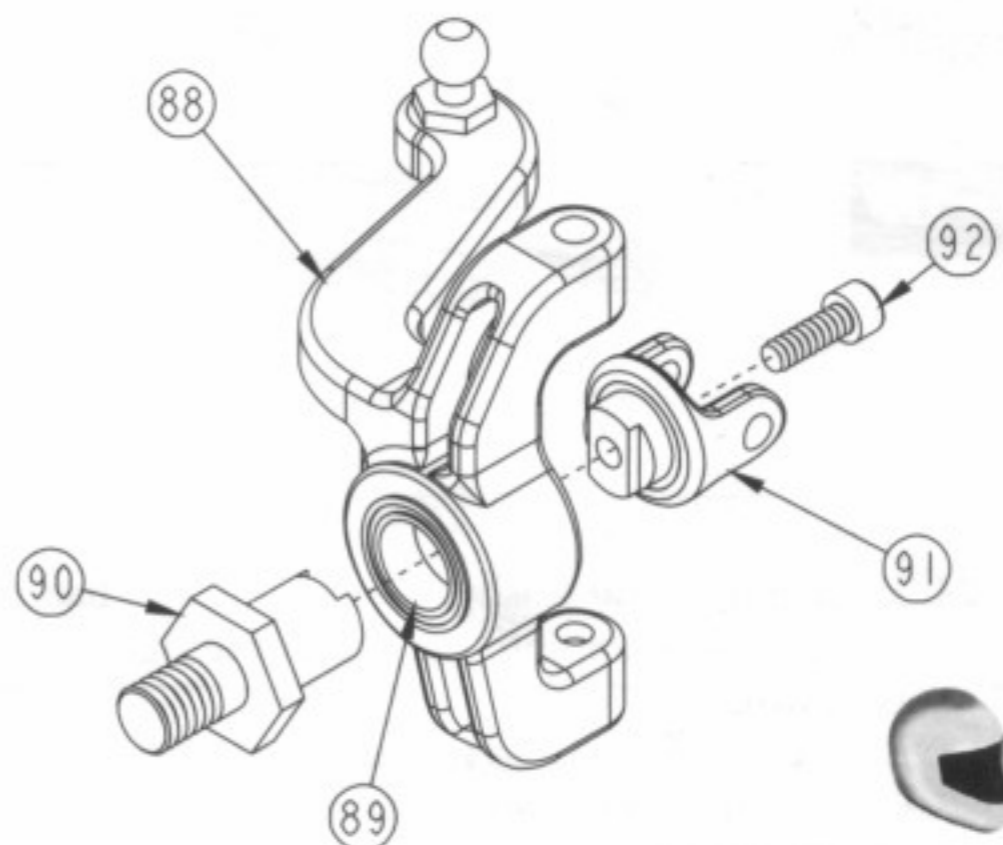


Figure 57

**Figure 58**



❑ Step 19. Position the front universal pivot (93) in the front dogbone (94) so that the holes in both parts are aligned.

❑ Step 20. Using pliers, carefully push a 1/16" x 3/8" spirol pin (95) through the dogbone (94) and universal pivot (93) until the pin (95) extends evenly out both sides of the dogbone (94).

*\*NOTE: Care should be taken not to "mushroom" the ends of the pins while pushing them in. Once the pin is in place, the dogbone should rotate freely around the universal pivot.*

❑ Step 21. Make two of the front dogbone assemblies.

*\* NOTE: Dogbone assemblies in some kits may have been pre-assembled at the factory.*

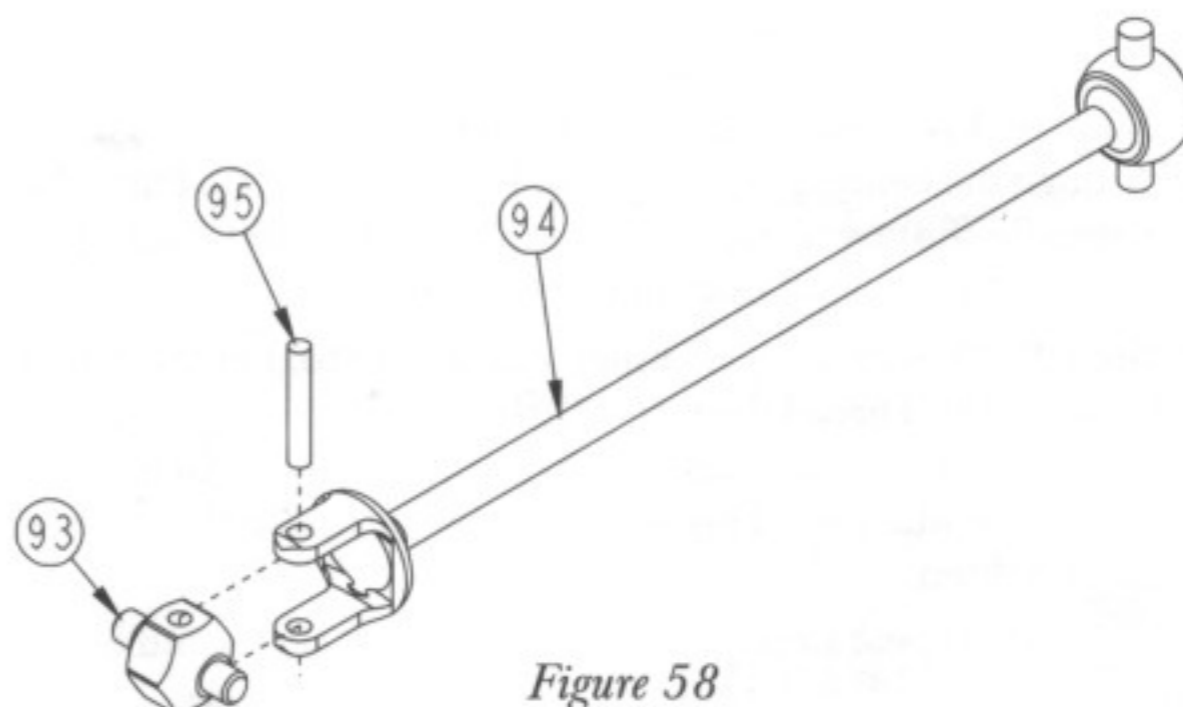


Figure 58

# BAG D (Continued)

## Figure 59

- ❑ Step 22. Using the small end of the Team Losi assembly wrench (96), spread the plastic universal yoke (91) – on the back side of the spindle (87), (88) – over the pins on the universal pivot (93).
- ❑ Step 23. Attach a dogbone assembly to each of the two front spindle assemblies.

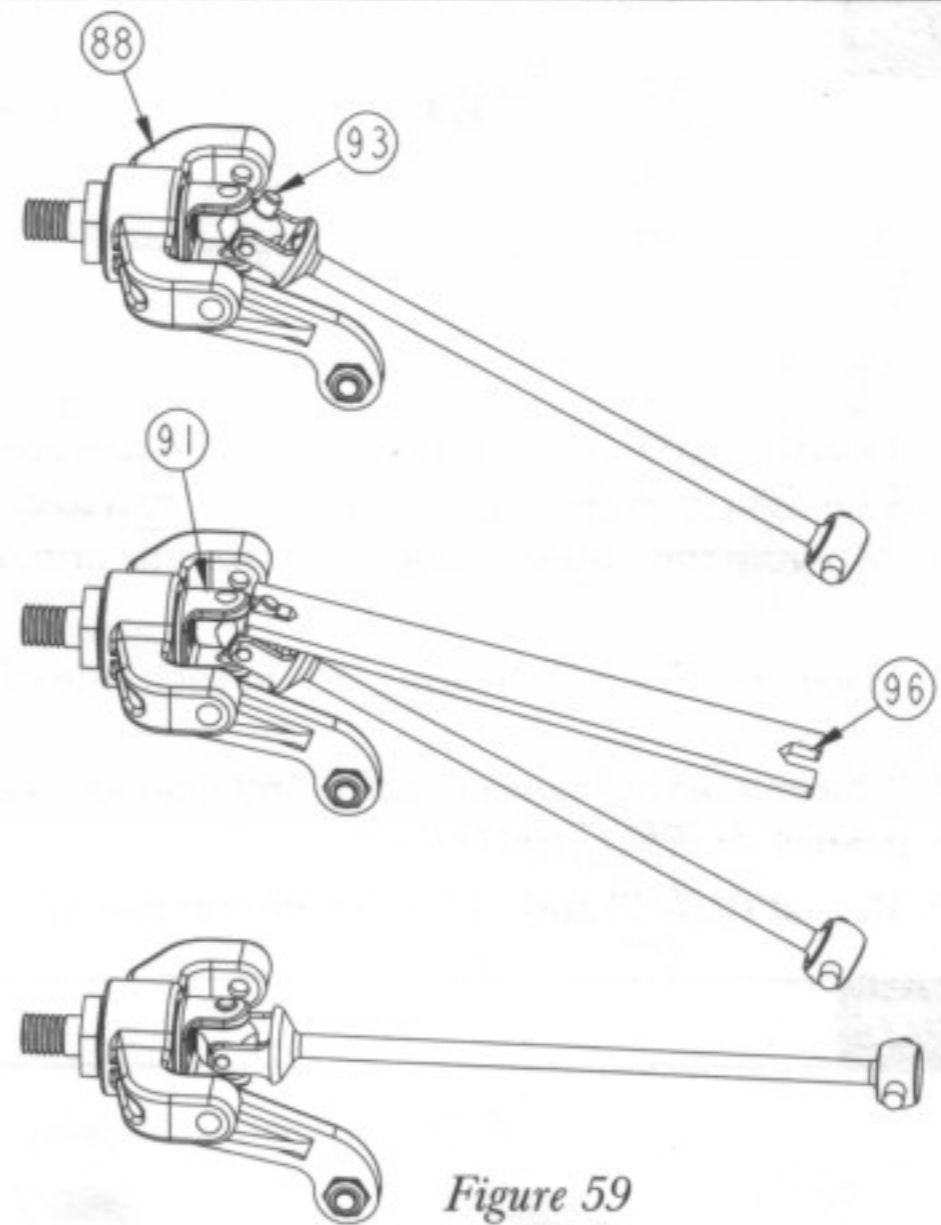
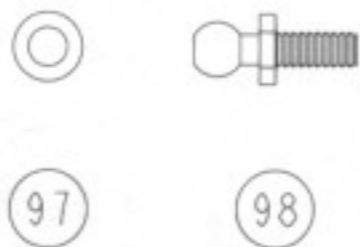


Figure 59

## Figure 60



- ❑ Step 24. Place a ball stud washer (97) over a 1/4" ball stud (98). Thread the ball stud (98) into the top of the right spindle carrier (100) as shown.

*\*NOTE: Be sure that the ball stud is threaded into the correct hole. The ball stud should be threaded into the hole with the raised area around it as shown in the illustration.*

- ❑ Step 25. Repeat step 24 for the left spindle carrier (99).

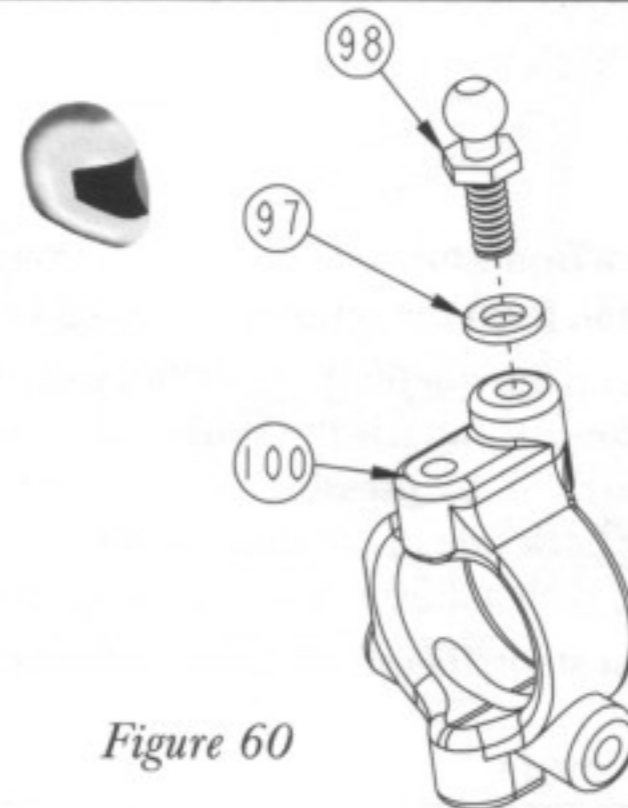
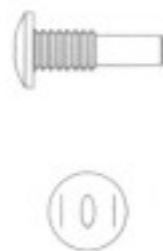


Figure 60

## Figure 61



- ❑ Step 26. Insert the dogbone (94) on the right spindle assembly through the center of the right spindle carrier (100). Place the right spindle (88) over the right spindle carrier (100) and align the holes in the top and bottom of the two parts.

- ❑ Step 27. Insert a kingpin/hinge pin screw (101) in the top of the spindle (88). Thread the screw (101) into the spindle (88), and tighten. Insert a second kingpin/hinge pin screw (101) in the bottom of the spindle (88). Thread the screw (101) into the spindle (88), and tighten.

- ❑ Step 28. Repeat steps 26 and 27 for the left side spindle (87) and carrier (99).

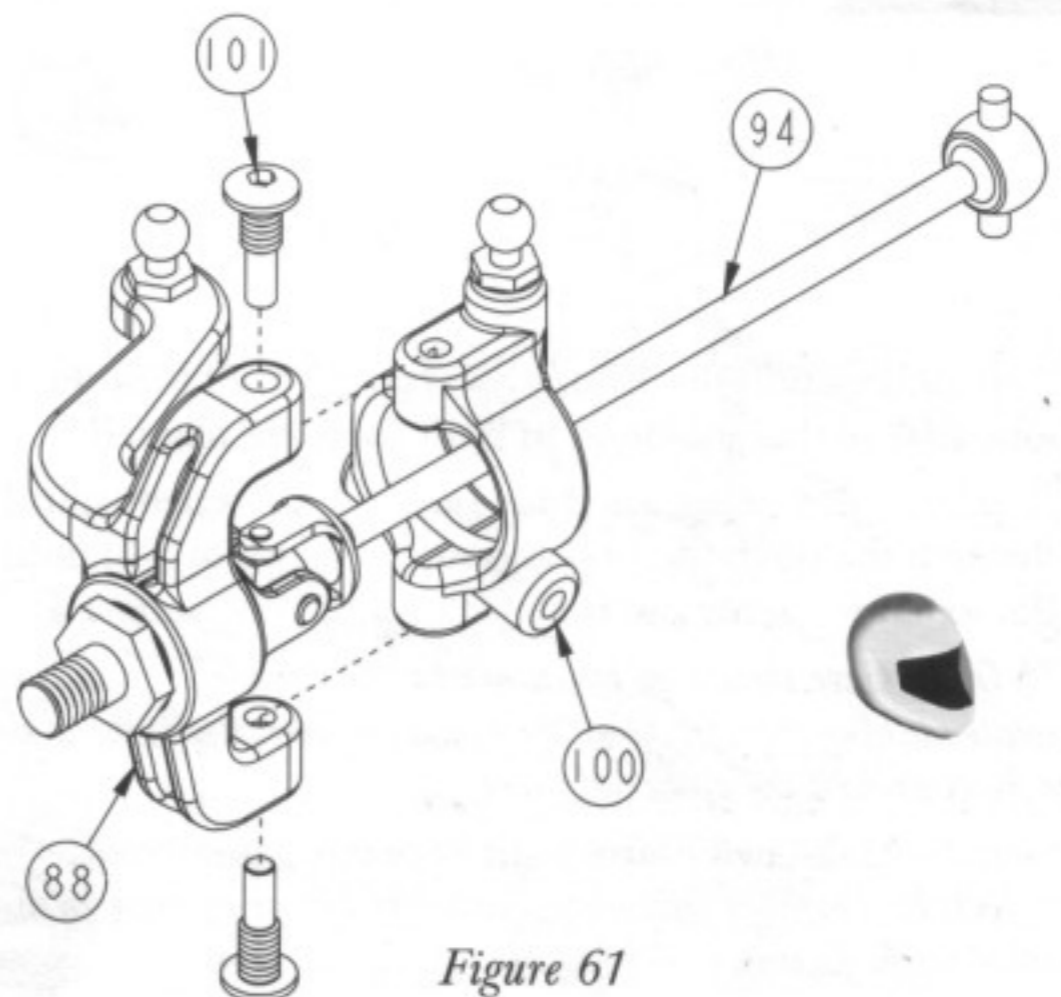
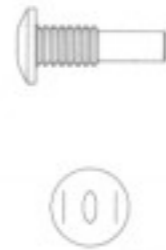


Figure 61

# BAG D (Continued)

## Figure 62



- ❑ Step 29. Place the right spindle carrier (100) in the right suspension arm (77) as shown. Line up the holes in the spindle carrier (100) with the holes in the suspension arm (77). Secure the spindle carrier (100) to the suspension arm (77) by threading a kingpin/hinge pin screw (101) into the front and back of the suspension arm (77).
- ❑ Step 30. Repeat step 29 for the left side of the car.

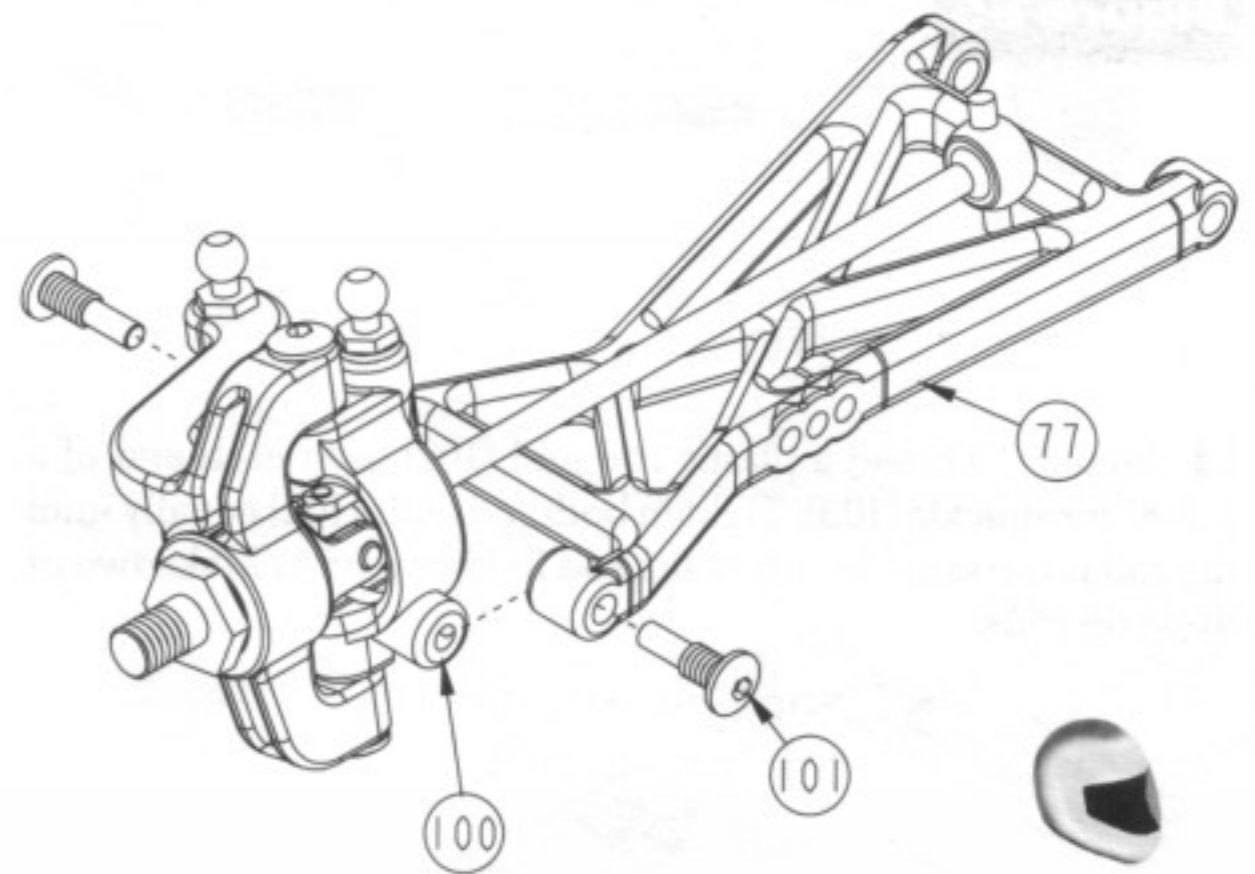


Figure 62

## Figure 63



- ❑ Step 31. Thread a plastic rod end (102) onto each end of a 1-5/8" turnbuckle (103). Tighten both rod ends (102) equally until the rod is the same length as the rod in Figure 63A. Make two of these camber links.

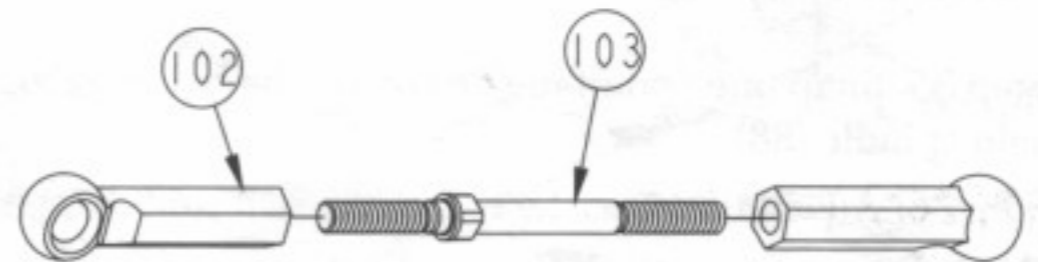


Figure 63



Figure 63A

## Figure 64



- ❑ Step 32. Place a foam ring (foam thing) (104) over each of the ball studs (62), (98) on the front shock tower (84) and the front spindle carriers (99), (100).
- ❑ Step 33. Attach one end of a camber link assembly to the ball stud (62) on the shock tower (84). Rotate the spindle carrier (99), (100) inward and insert the dogbone (94) into the front diff, lining up the pins on the dogbone (94) with the slots in the front diff. With the dogbone (94) in place, attach the other end of the camber link to the ball stud (98) on the spindle carrier (99), (100). Attach a camber link to both the left and right side of the car.

🔑 Try to mount all of the camber links so that the threads adjust in the same direction (e.g. forward makes the rod shorter). This will help to make adjustments easier once the car is assembled.

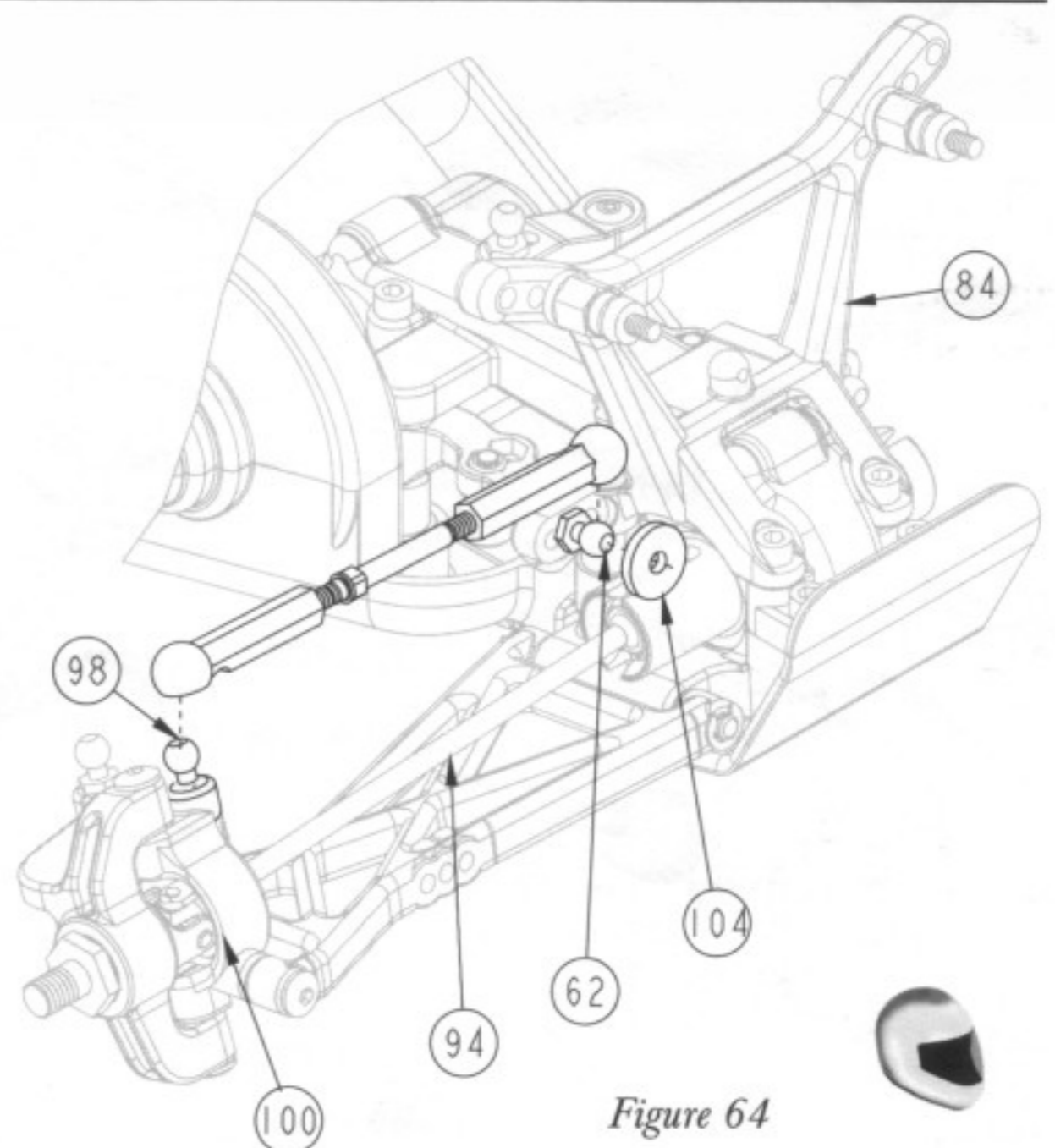


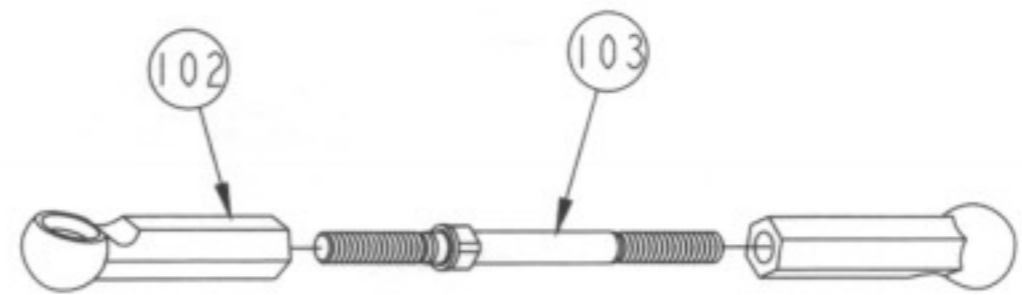
Figure 64

# BAG D (Continued)

**Figure 65**



103



*Figure 65*

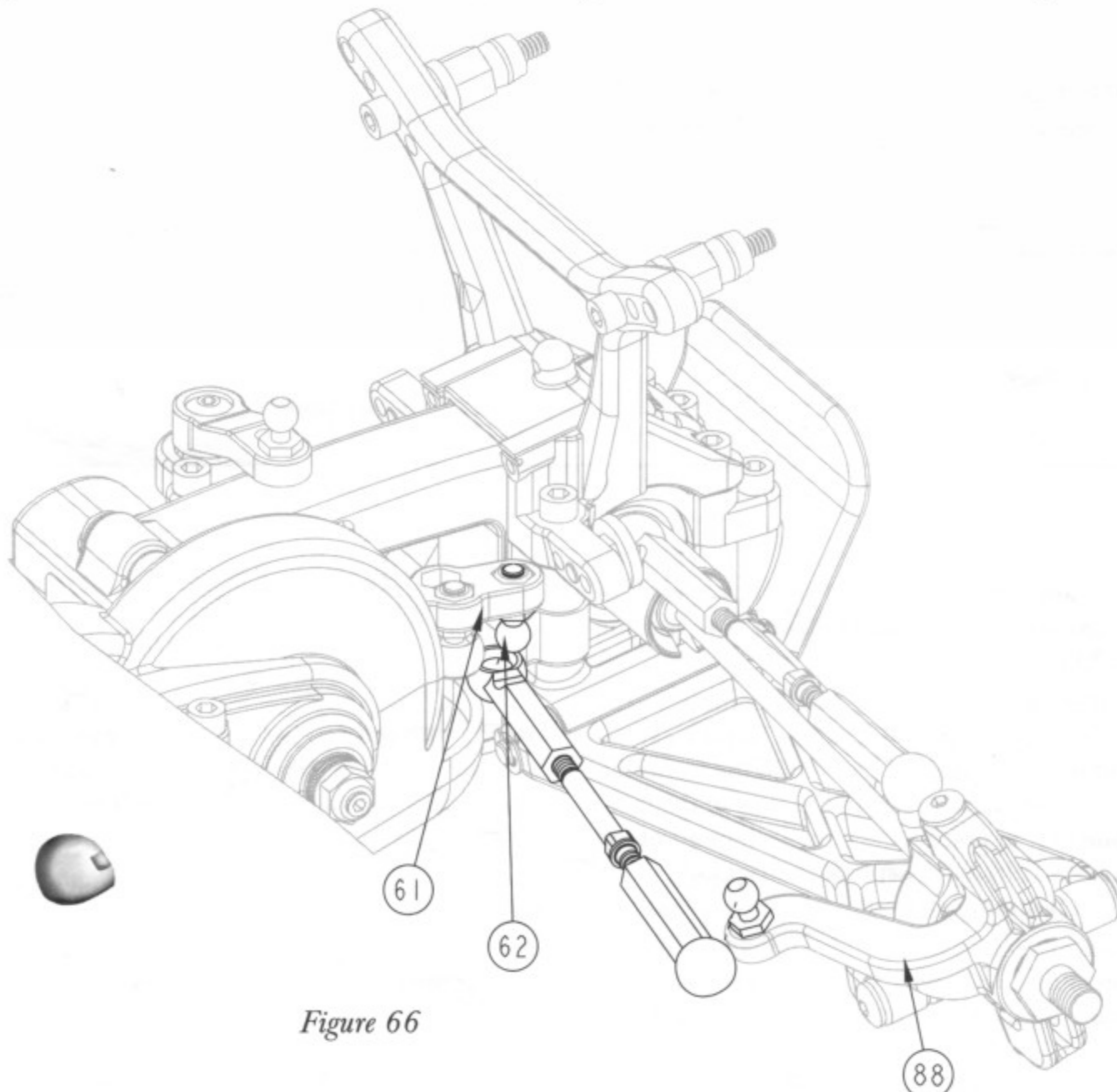
- ❑ Step 34. Thread a plastic rod end (102) onto each end of a 1-5/8" turnbuckle (103). Tighten both rod ends (102) equally until the rod is the same length as the rod in Figure 65A. Make two of these tie rods.



*Figure 65A*

**Figure 66**

- ❑ Step 35. Snap one end of the tie rod on the ball stud (62) in the steering idler arm (61). Snap the other end to the ball stud (62) in the right spindle (88).
- ❑ Step 36. Attach the other tie rod to the ball studs (62) in the steering bellcrank (63) and the left spindle (87).
  - 🔑 Once again, attach the turnbuckles so that the threads adjust in the same direction for easier adjustments.



*Figure 66*

# BAG E

**Figure 67**



- ❑ Step 1. Insert a 1/8" stainless washer (75) into the recessed area at the rear of the right rear suspension pivot (108).
- ❑ Step 2. Place the right rear suspension arm (109) – **marked 'L'** – over the right rear suspension pivot (108). Line up the holes in the arm (109) with the holes in the suspension pivot (108) and attach the two parts by inserting an inner rear hinge pin (107) all the way through both parts.

**! IMPORTANT NOTE:** Check that the suspension pivot is installed correctly. The washer should be to the rear (opposite side of the arm that the letter is on), and the side of the pivot with the raised area around the screws should be on top.

- ❑ Step 3. Repeat steps 1 and 2 for the left suspension pivot (105) and left suspension arm (106) – **marked 'R'**.

**! IMPORTANT NOTE:** The letters on the rear suspension arms are marked backwards. This was not a mistake! The arms are used in the other configuration on other cars. In order to optimize the overall layout of the XX-4, the suspension arms were reversed. Be sure that the arm marked 'L' is on the right side, and the arm marked 'R' is on the left side.

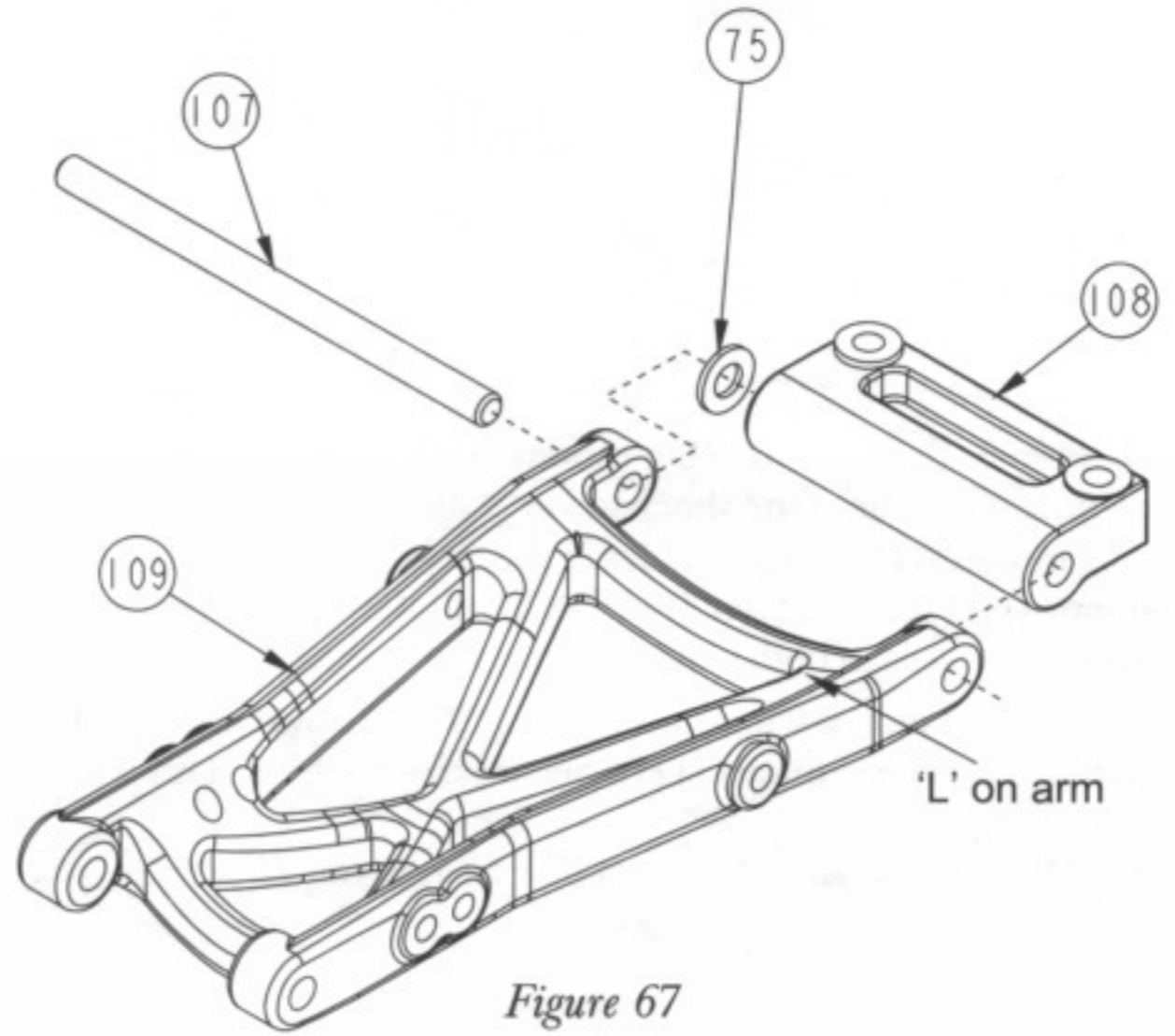
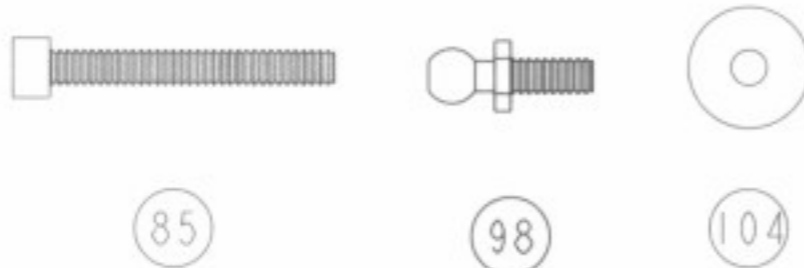


Figure 67

**Figure 68**



- ❑ Step 4. Thread a 1/4" ball stud (98) into each of the #2 holes on the bottom of the rear shock tower (110). Mount the ball studs (98) from the rear as shown. Place a foam thing (104) over the two ball studs (98).

- ❑ Step 5. Insert a 4-40 x 7/8" cap-head screw (85), from the front, through the third hole in, on the top of the shock tower (110) on each side. Thread a top shock mount bushing (86) onto each of the two screws (85), and tighten.

**! IMPORTANT NOTE:** The shock mount bushings and ball studs should be on the same side of the shock tower as shown in the illustration. Do not overtighten the shock mount bushings.

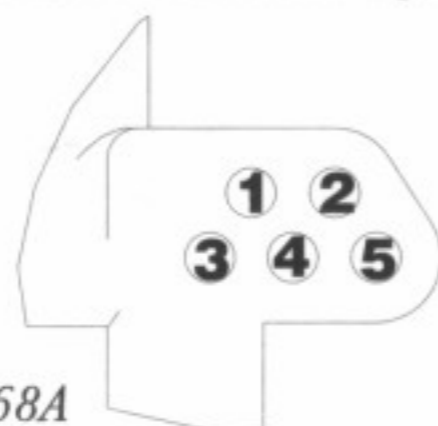


Figure 68A

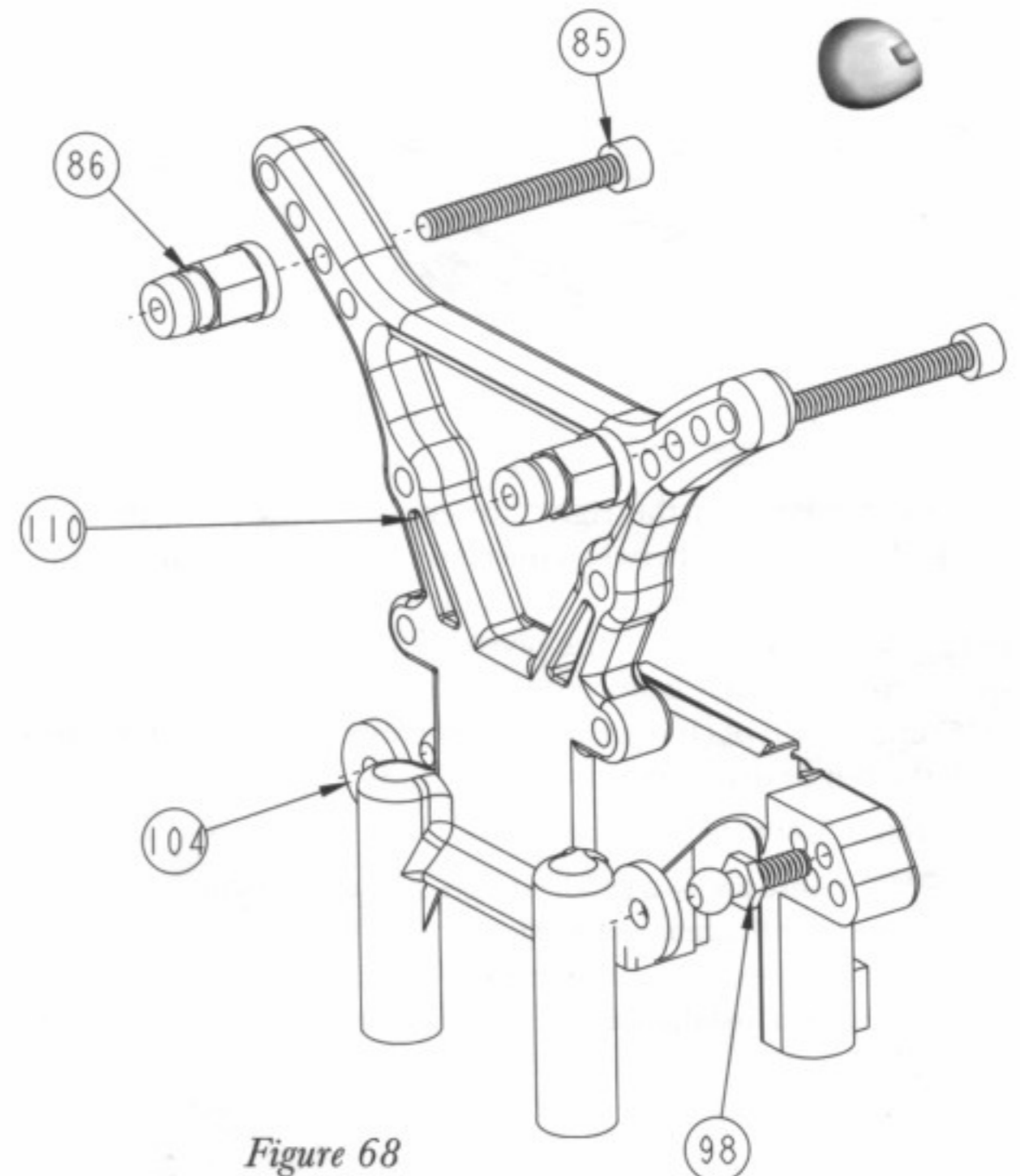
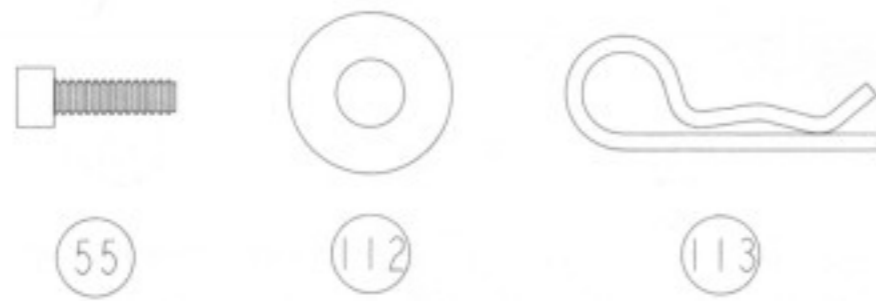


Figure 68

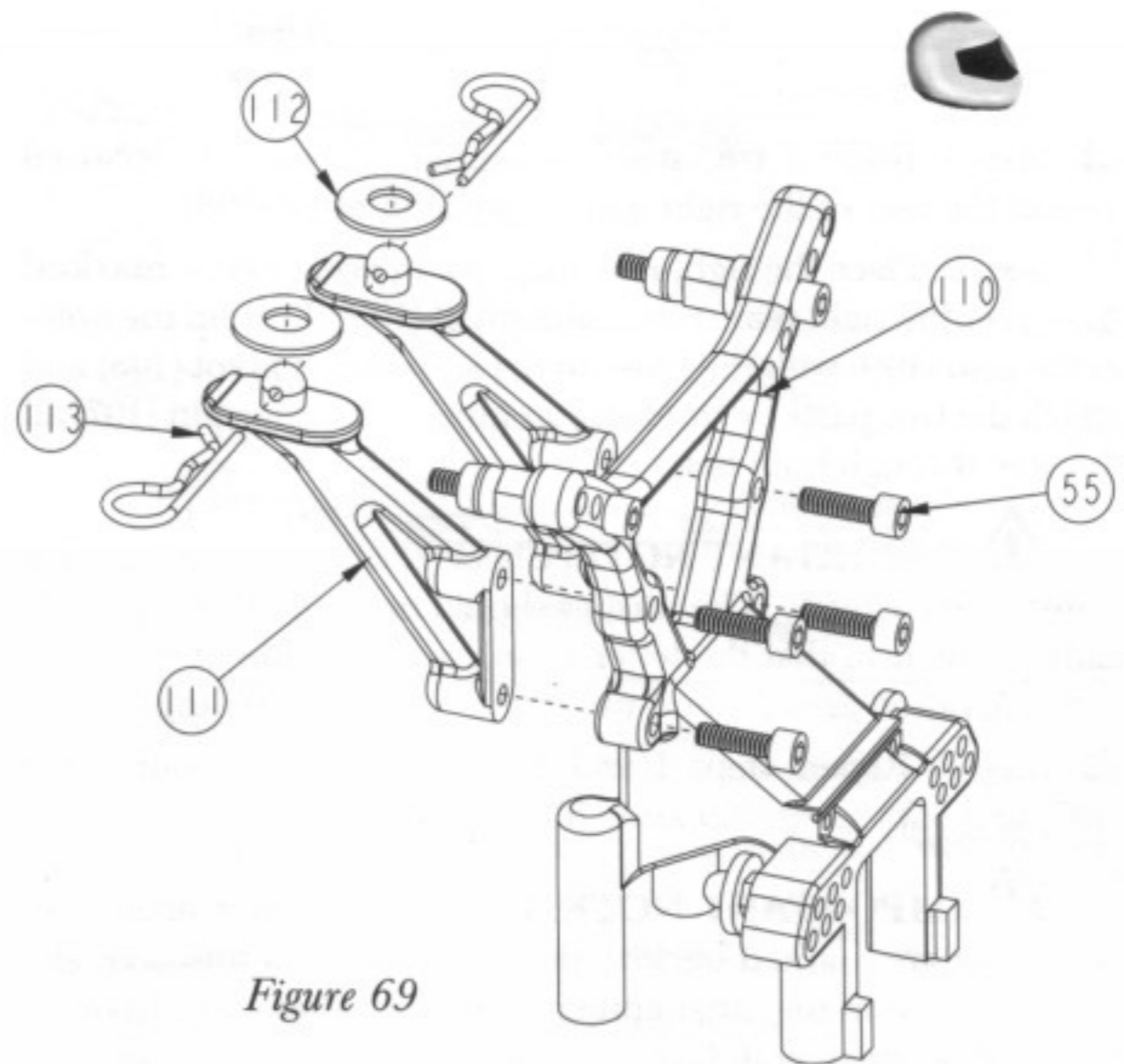
# BAG E (Continued)

**Figure 69**



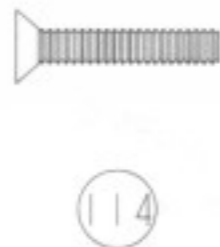
- ❑ Step 6. Position the wing mount (111), with the posts pointing up, at the rear of the shock tower (110). Align the holes in the wing mount (111) with the holes in the tower (110) and secure the mount (111) to the tower (110) with two 4-40 x 3/8" cap-head screws (55). Attach both wing mounts (111) to the rear tower (110).
- ❑ Step 7. Place a wing mount washer (112) over the post on each of the wing mounts (111). Secure the washers (112) with a body clip (113).

*\*NOTE: The wing will be attached later, in Bag H.*



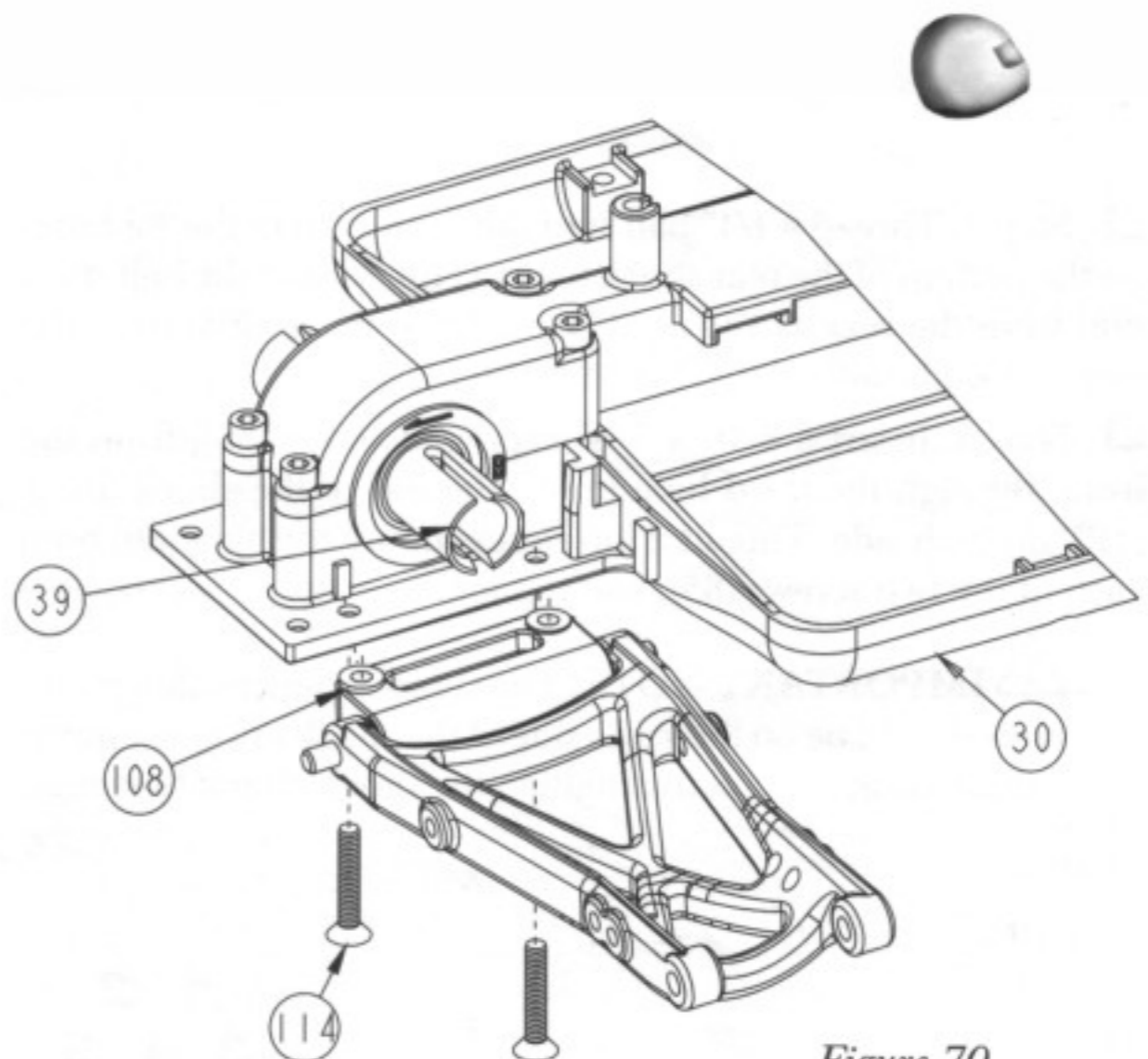
*Figure 69*

**Figure 70**



- ❑ Step 8. Position the right suspension pivot (with the arm marked 'L' attached) between the chassis (30) and the differential outdrive (39). Line up the holes in the pivot (108) with the holes in the chassis (30). Secure the pivot (108) to the chassis (30) with two 4-40 x 5/8" flat-head screws (114). Thread the two screws (114) into the pivot (108) until the end of each screw (114) is flush with the top of the suspension pivot (108).
- ❑ Step 9. Repeat step 8 for the left suspension pivot (105).

🔑 There are two small wedges included in your kit. These pieces fit under the rear suspension pivots to adjust the anti-squat. Put these wedges in your spare parts box for now. Anti-squat adjustment and installation of the wedges will be discussed in the tip section.



*Figure 70*

# BAG E (Continued)

## Figure 71

🔑 Before proceeding to step 10, locate the 4-40 thread-forming screw used prior to step 34 in Bag B and thread the four holes in the bottom of the rear shock tower. Apply a small amount of white assembly grease to the screws before threading them into the holes.

❑ Step 10. Place the rear shock tower (110) over the back of the main chassis cover (53), on top of the rear suspension pivots (105), (108) with the wing mounts (111) pointing back. Insert the tab on the front of the shock tower (110) into the indexed area on the chassis (30) and line up the four holes in the bottom of the shock tower (110) with the four screws (114) already installed in the suspension pivots (105), (108). Thread the four 4-40 x 5/8" flat-head screws (114) into the holes in the shock tower (110) evenly until all four screws (114) are tight.

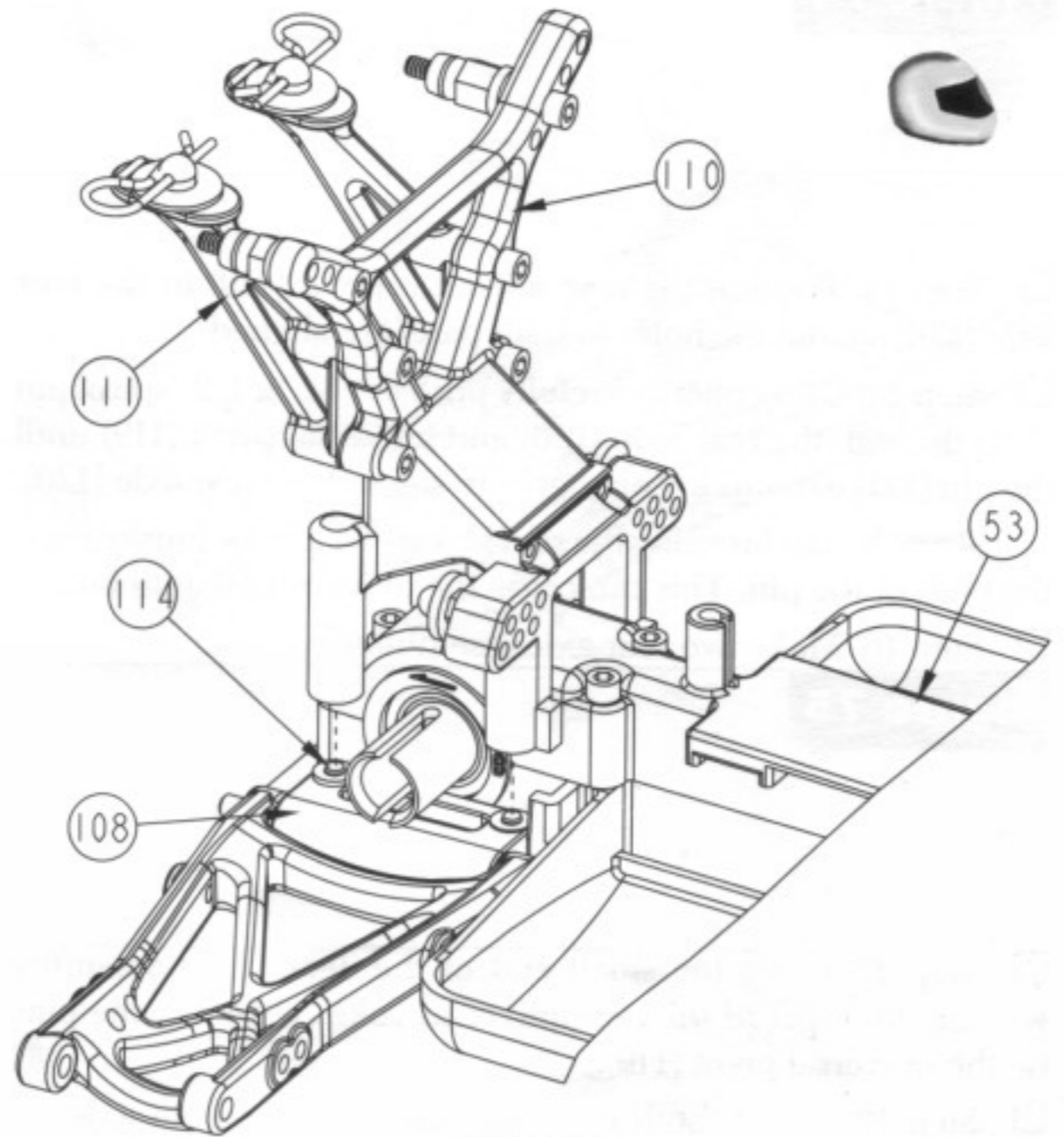


Figure 71

## Figure 72

❑ Step 11. Position the rear hinge pin brace (177) over the end of each inner rear hinge pin (107) as shown.

❑ Step 12. Attach the rear bumper (115) to the back of the chassis (30) by threading two 4-40 x 3/8" flat-head screws (116) through the chassis (30) and into the holes in the bumper (115).

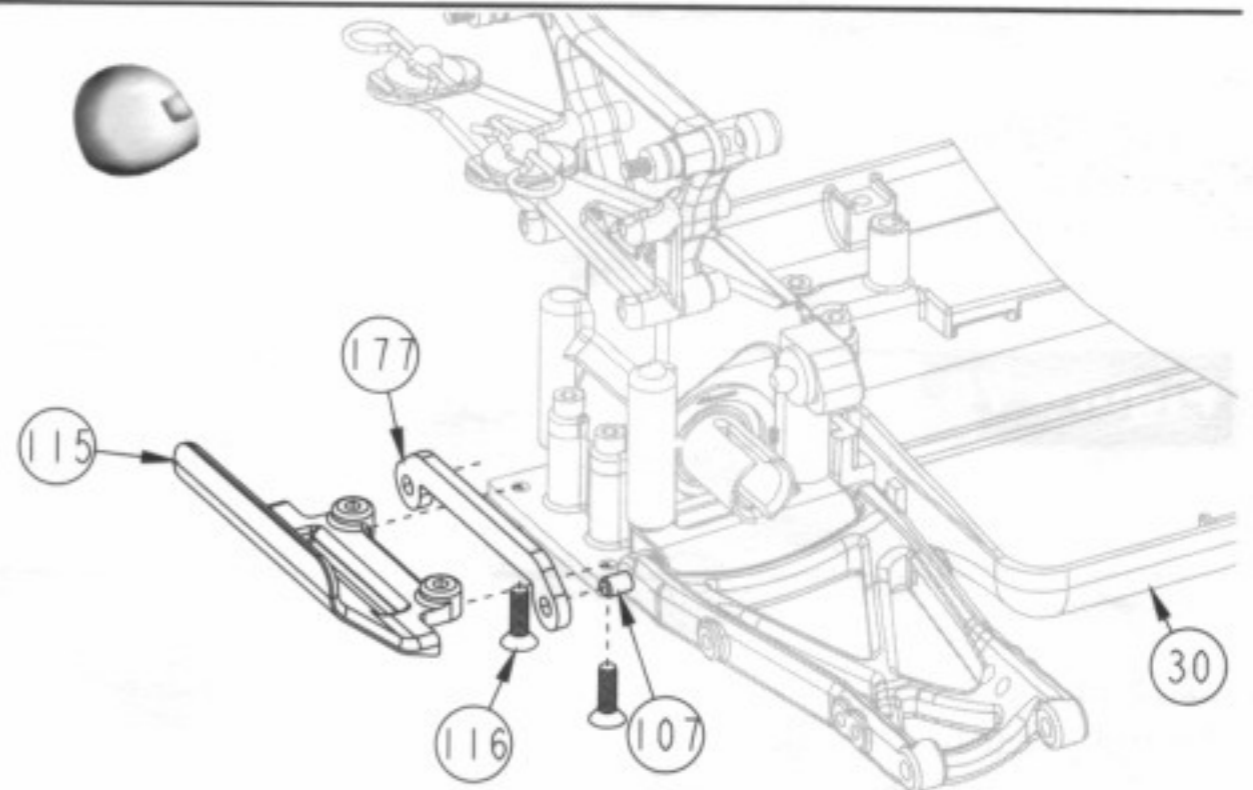


Figure 72

## Figure 73

❑ Step 13. Attach the rear dogbone (117) to the rear universal yoke (118) by lining up the slot on the dogbone (117) with the groove in the universal yoke (118). Secure the two pieces with a 4-40 x 3/8" cap-head screw (55). Make two rear dogbone assemblies.

🔑 A small amount of liquid thread-lock on the threads of the screw will hold the screw securely in place, keeping the yoke from coming loose.

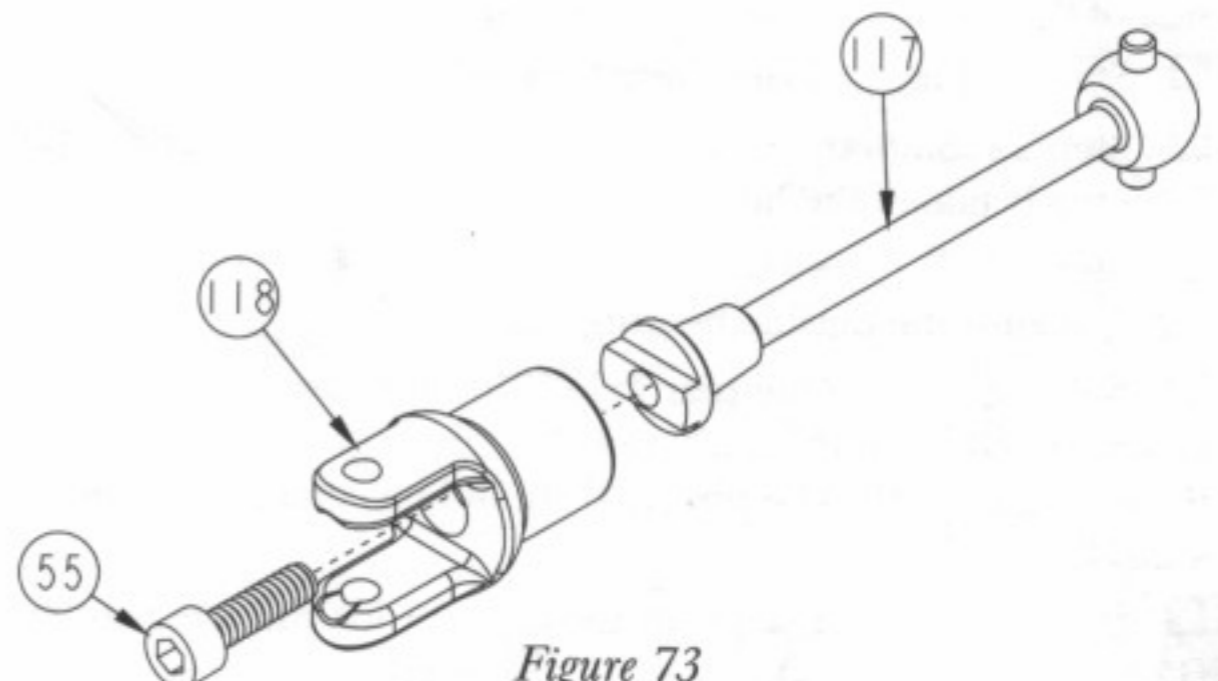
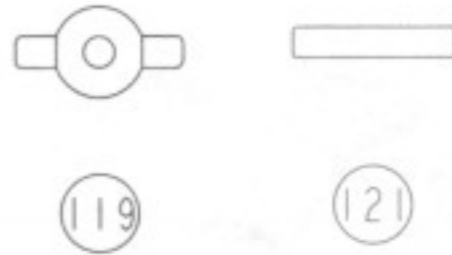


Figure 73

# BAG E (Continued)

**Figure 74**



❑ Step 14. Position the rear universal pivot (119) in the rear axle (120) so that the holes in both parts are aligned.

❑ Step 15. Using pliers, carefully push a 3/32" x 1/2" spirol pin (121) through the rear axle (120) and universal pivot (119) until the pin (121) extends evenly out both sides of the rear axle (120).

⚠ When inserting the pin, be careful not to "mushroom" the ends of the pin. This can cause the universal pivot to bind.

❑ Step 16. Make two rear axle assemblies.

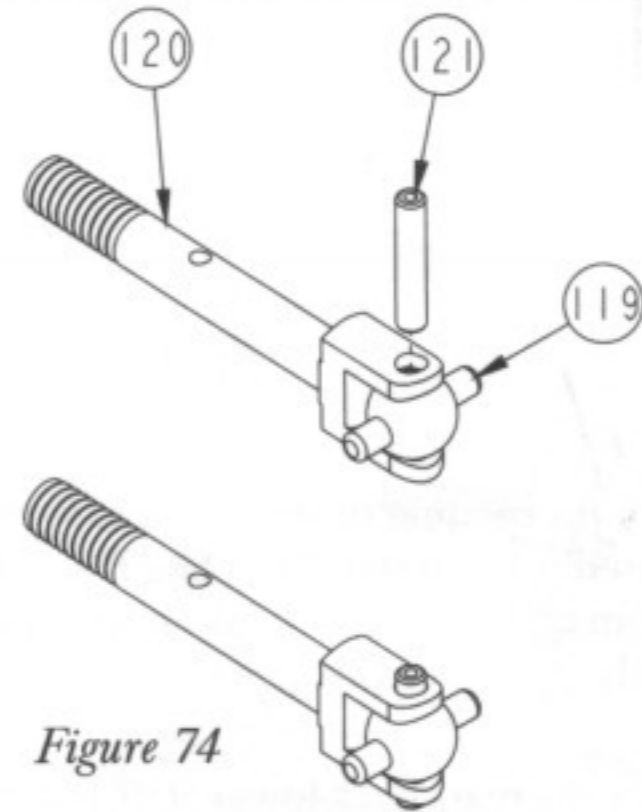


Figure 74

**Figure 75**

❑ Step 17. Using the small end of the Team Losi assembly wrench (96), spread the rear universal yoke (118) over the pins on the universal pivot (119).

❑ Step 18. Attach both dogbone assemblies to both axle assemblies.

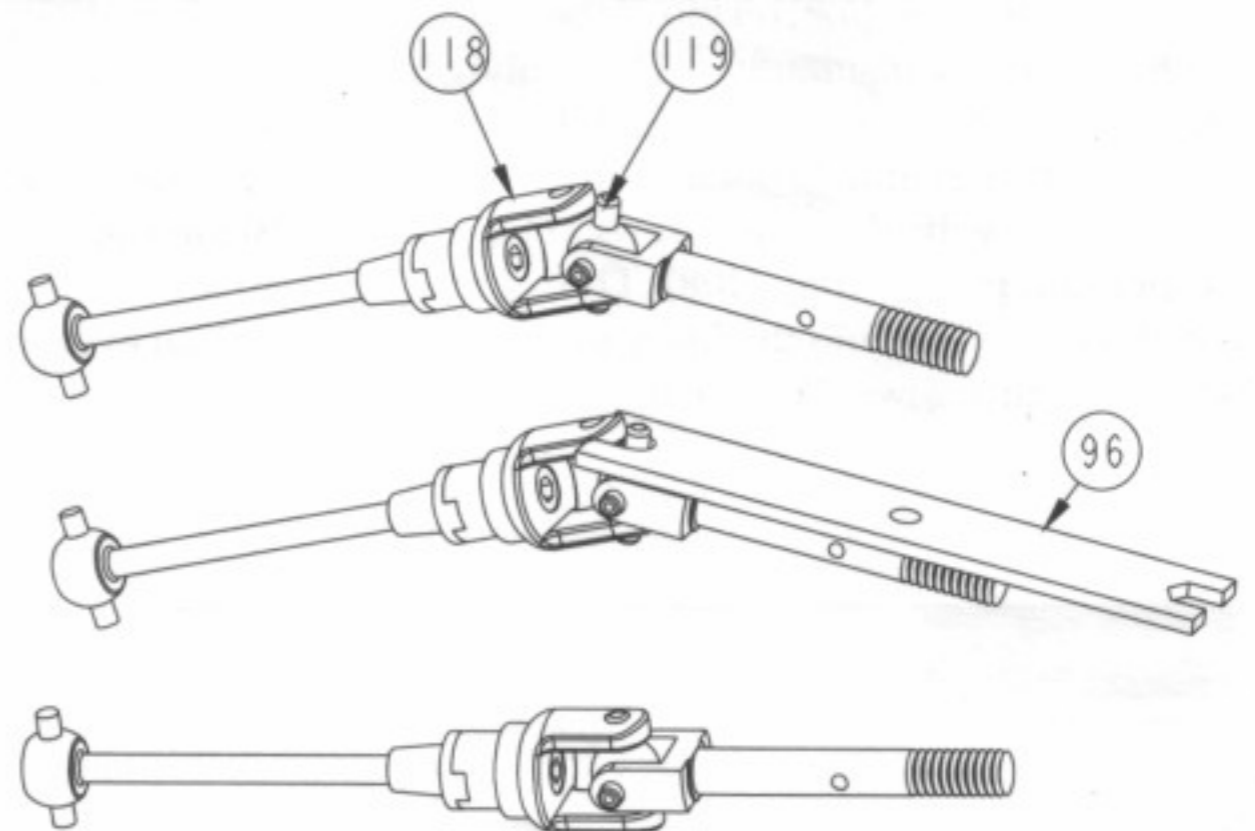


Figure 75

**Figure 76**



❑ Step 19. Press a 3/16" x 3/8" bearing (20) into each side of the right rear hub (125).

*NOTE: If the bearings only have one Teflon™ seal (tan, woven looking) in them, position the Teflon™ seal to the outside.*

❑ Step 20. Thread a 1/4" ball stud (98) into the #2 hole in the rear hub (125). The ball stud (98) should be threaded into the side of the hub (125) with the recessed area and the letter 'R'.

❑ Step 21. Place a foam thing (104) over the ball stud (98).

❑ Step 22. Slide the rear axle (120) through the bearings (20) from the inside of the hub (125).

❑ Step 23. Place a rear axle spacer (123) over the rear axle (120), against the outside bearing (20).

❑ Step 24. Secure the rear axle (120) and spacer (123) by inserting a 1/16" x 7/16" spirol pin (124) through the small hole in the rear axle (120). The pin (124) should be centered in the rear axle (120).

❑ Step 25. Repeat steps 19 through 25 for the left rear hub (122).

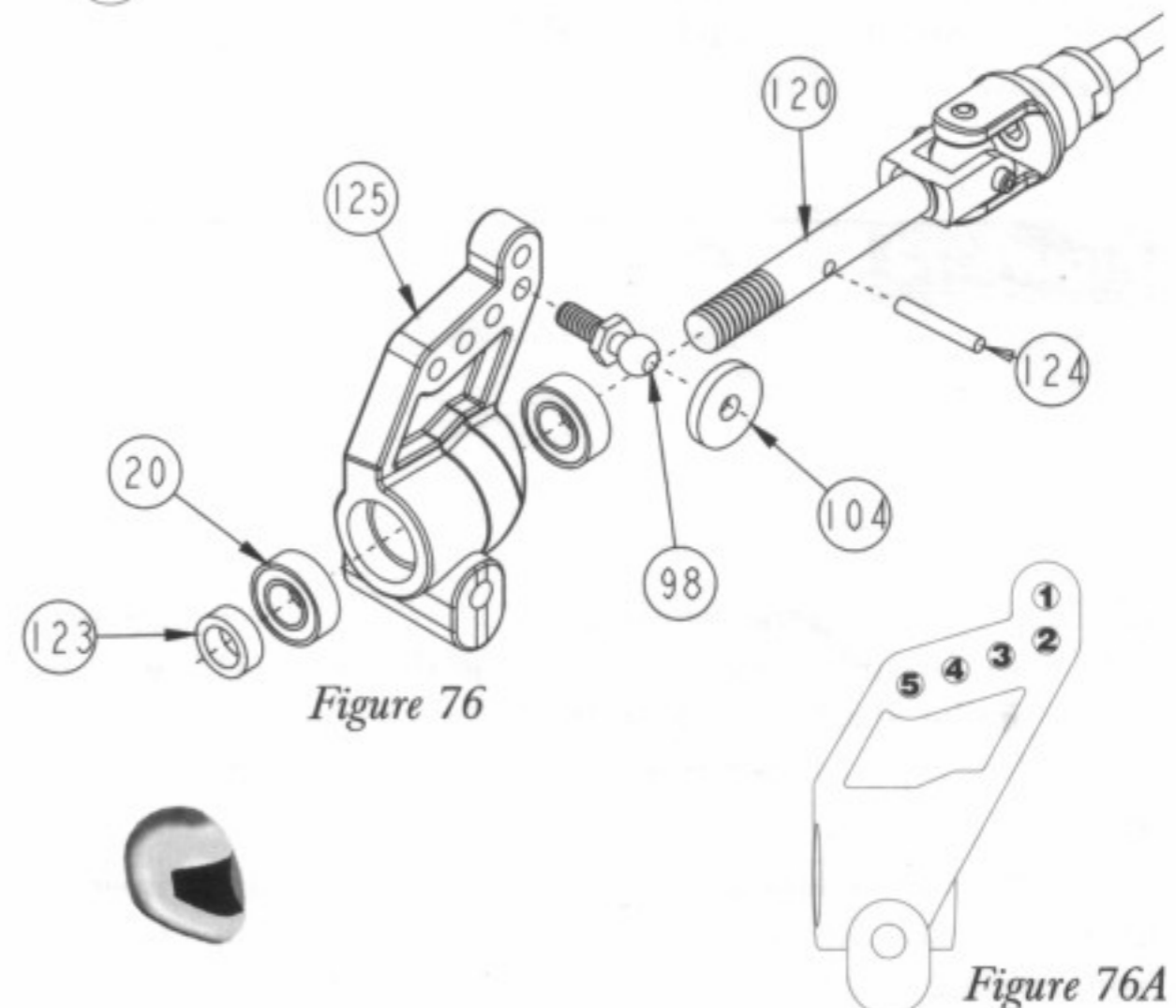
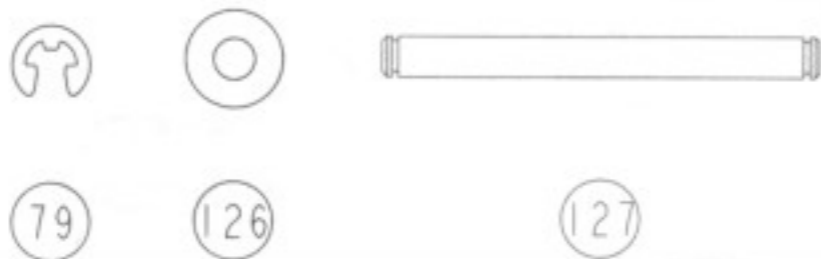


Figure 76

Figure 76A

# BAG E (Continued)

**Figure 77**



❑ Step 26. Place the right rear hub (125) between the outer rails of the right rear suspension arm (marked 'L')(109). Be sure that the ball stud (98) is towards the front of the car. Position a rear hub spacer (126) between the hub (125) and suspension arm (109) on both the front and rear side of the hub (125).

*\*NOTE: If there is a reinforcement brace attached to the outside of the arm, remove it before installing the rear hub.*

❑ Step 27. Insert an outer rear hinge pin (127) into the suspension arm (109), through each of the two spacers (126), and the rear hub (125). Secure the hinge pin (127) with two 1/8" E-clips (79).

❑ Step 28. Repeat steps 26 and 27 for the right rear suspension arm (marked 'R') (106).

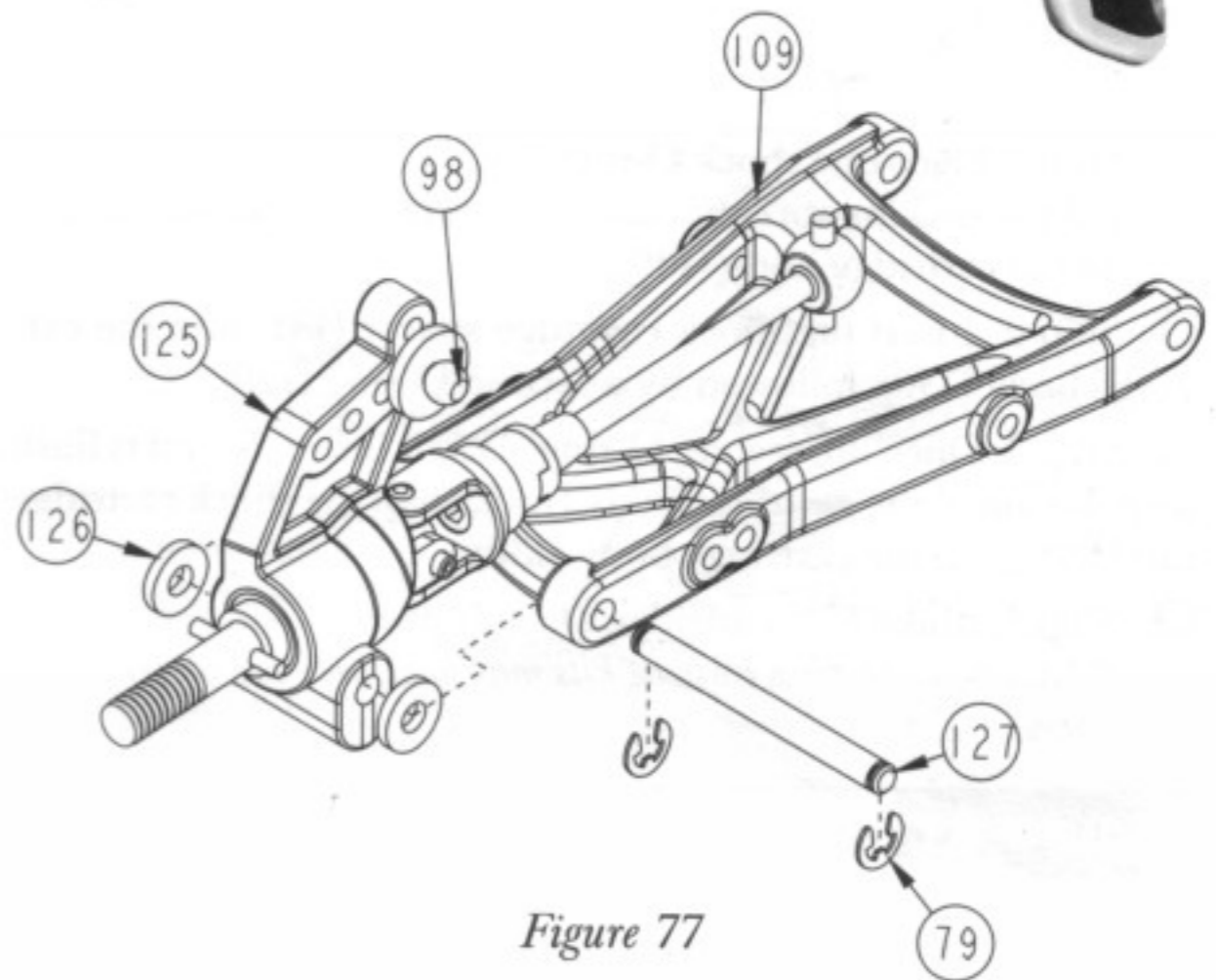


Figure 77

**Figure 78**



❑ Step 29. Thread a plastic rod end (102) onto each end of a 1-3/8" turnbuckle (128). Tighten both rod ends (102) equally until the rod is the same length as the rod in Figure 78A. Make two of these camber link assemblies.

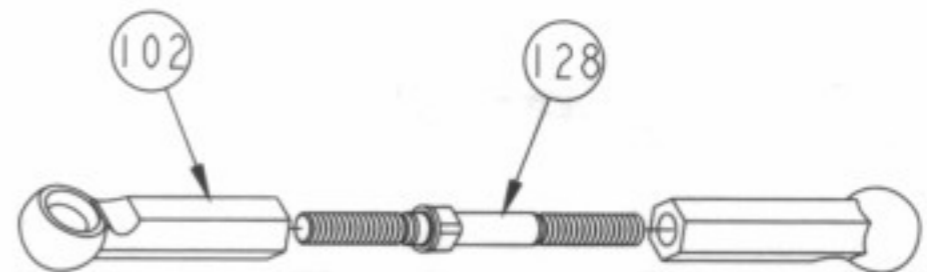


Figure 78



Figure 78A

**Figure 79**

❑ Step 30. Attach one end of a camber link assembly to the ball stud (98) on the rear shock tower (110). Rotate the rear hub (122), (125) inward and insert the dogbone (117) into the rear diff, lining up the pins on the dogbone (117) with the slots in the rear diff. With the dogbone (117) in place, attach the other end of the camber link to the ball stud (98) on the rear hub (122), (125). Attach a camber link to both the left and right side of the car.

🔑 Try to mount all of the camber links so that the threads adjust in the same direction (e.g. forward makes the rod shorter). This will help to make adjustments easier once the car is assembled.

*\*NOTE: Try to leave your car sitting on a flat surface until the shocks are assembled. This will keep the dogbones correctly inserted in the differentials until the shocks can be installed.*

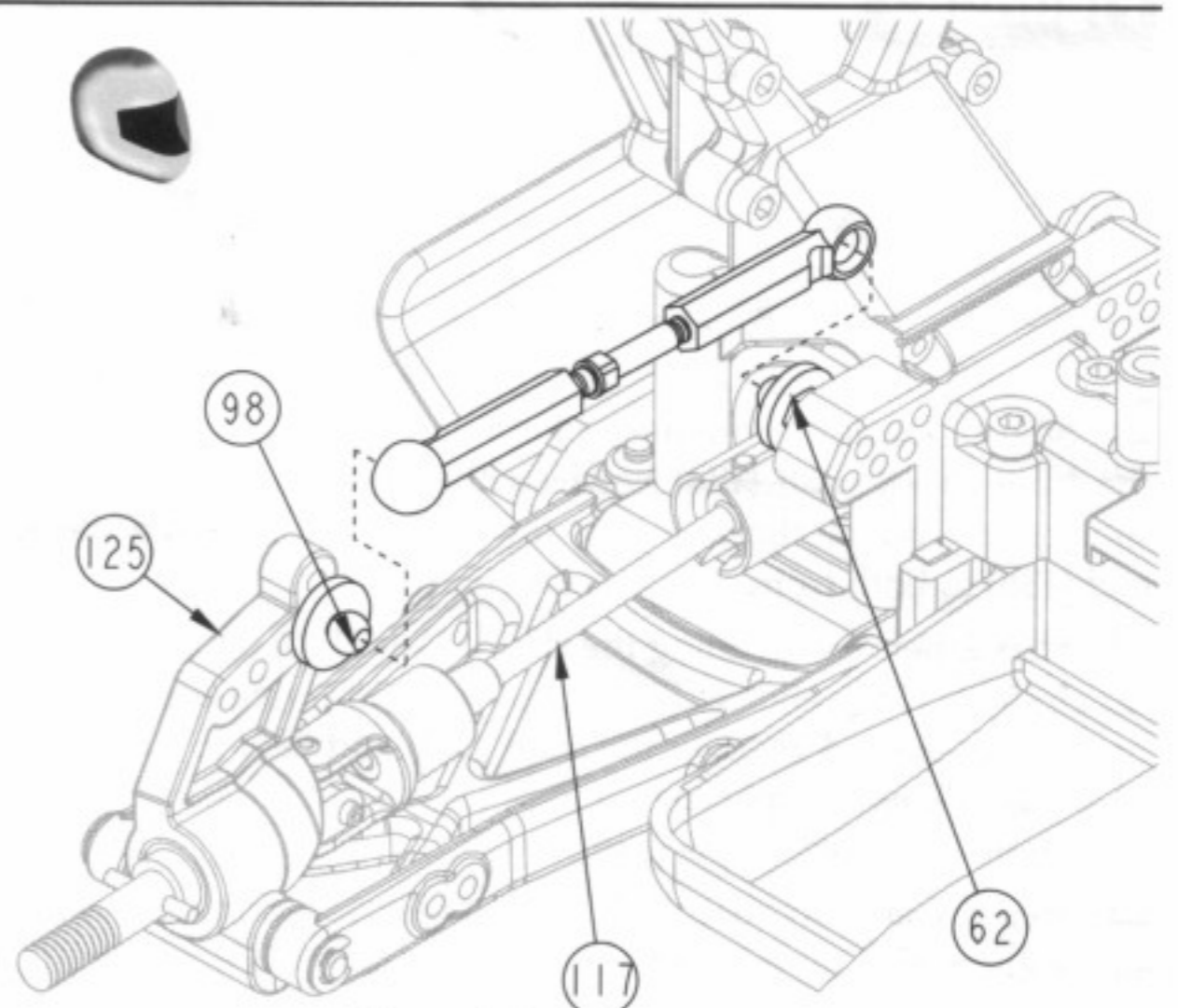


Figure 79

# BAG F

## Figure 80

- ❑ Step 1. Place one shock O-ring (129) into the shock cartridge body (130), making sure that the O-ring (129) sits flat on the bottom of the cartridge body (130).
- ❑ Step 2. Insert the shock cartridge spacer (131) into the cartridge body (130), followed by a second O-ring (129).
- ❑ Step 3. Once the second O-ring (129) is inserted, and is flush with the top of the cartridge body (130), snap the shock cartridge cap (132) onto the cartridge body (130).
- ❑ Step 4. Make four cartridge assemblies.

\* NOTE: Cartridges in some kits may have been pre-assembled at the factory.

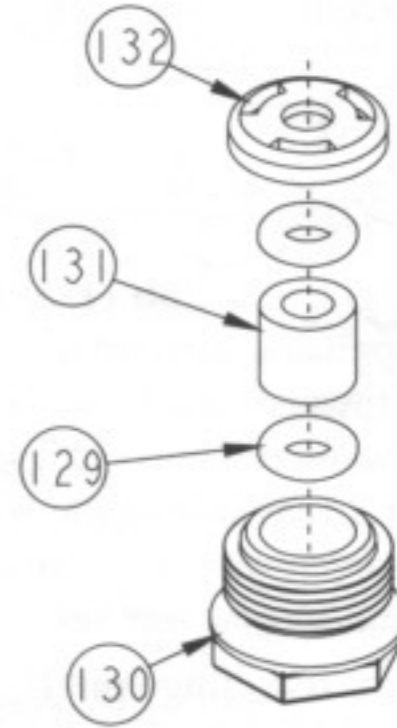
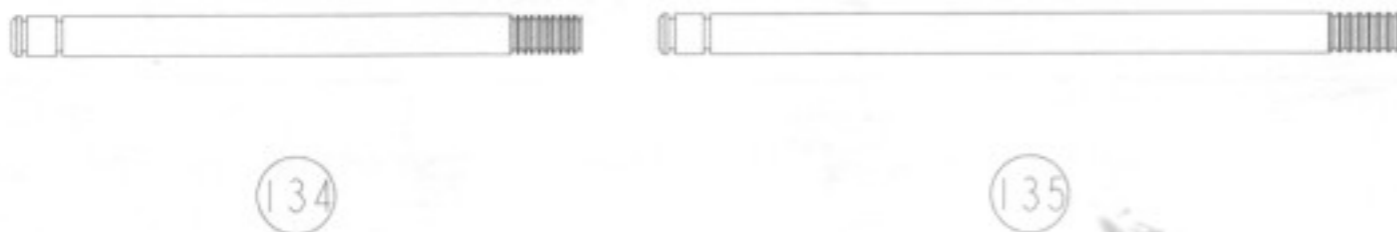


Figure 80

## Figure 81



- ❑ Step 5. Place a drop of shock fluid (133) on the grooved end of each shock shaft [front (134), rear (135)] and slide a cartridge, hex end first, down the shock shaft (134), (135) toward the threads.

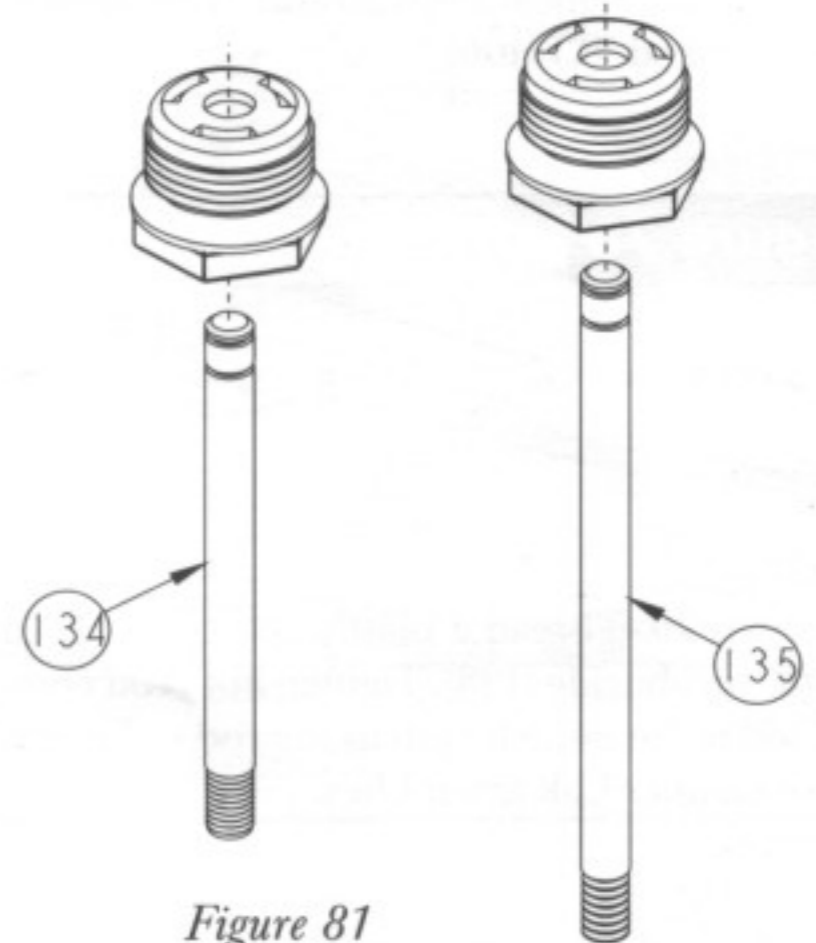


Figure 81

## Figure 82



- ❑ Step 6. Using needle-nose pliers or small vise grips, grasp the front shock shaft (134) between the grooves, and thread a shock end (136) all the way onto the shaft (134). Attach a shock end (136) to both front shock shafts (134).
- ❑ Step 7. Before threading the shock ends (136) onto the rear shock shafts (135), slide a 'B' shock spacer (138) (the larger of the two spacers, marked 'B') over the shaft (135) and next to the cartridge. Once the spacers are in place, thread the shock ends (136) onto the shock shafts (135).
- ❑ Step 8. Carefully snap a 1/4" swivel ball (137) into each of the shock ends (136) on the four shock shafts (134), (135).

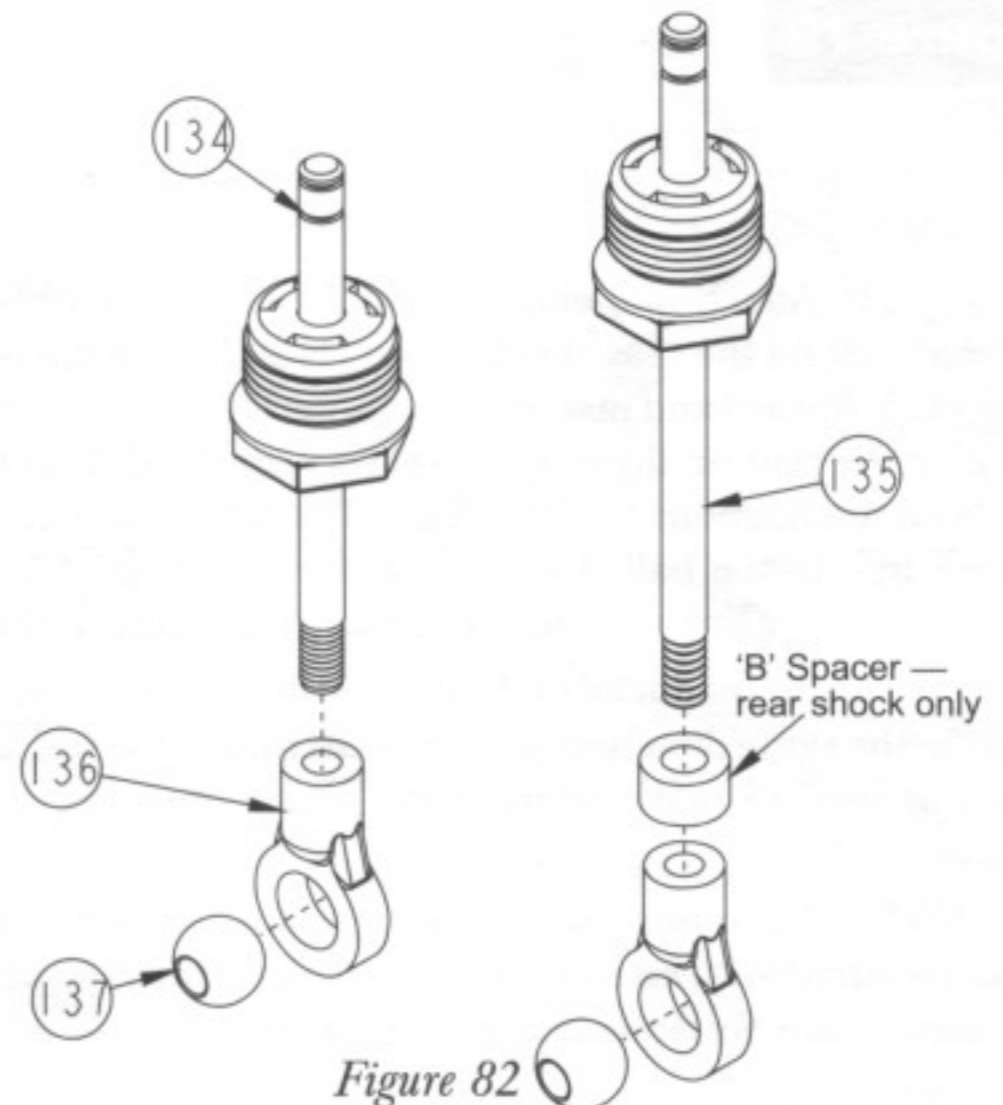
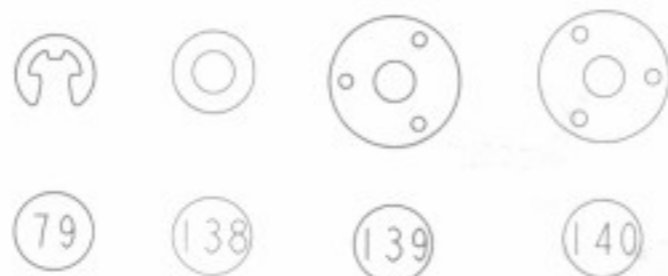


Figure 82

# BAG F (Continued)

**Figure 83**



❑ Step 9. Snap a 1/8" E-clip (79) into the groove closest to the cartridge on both front shock shafts (134).

❑ Step 10. Before attaching the E-clip to the rear shock shafts (135), slide an 'A' shock spacer (138) (the smaller of the two spacers, marked 'A') over the shaft (134) and next to the cartridge. Once the spacers are in place, snap a 1/8" E-clip (79) into the groove closest to the cartridge on both front shock shafts (134).

\*NOTE: Shock spacers are only used on the rear shock shafts in this step.

❑ Step 11. Slide a black, #57 shock piston (139) onto each of the two front shock shafts (134) until the piston rests against the E-clip (79). Secure the pistons (139) to the shafts (134) with a second E-clip (79).

\*NOTE: Be sure to attach the black, #57 pistons to the short shock shafts. The long shock shafts are for the rear.

❑ Step 12. Slide a red, #56 shock piston (140) onto each of the two rear shock shafts (135) until the piston rests against the E-clip (79). Secure the pistons (140) to the shafts (135) with a second E-clip (79).

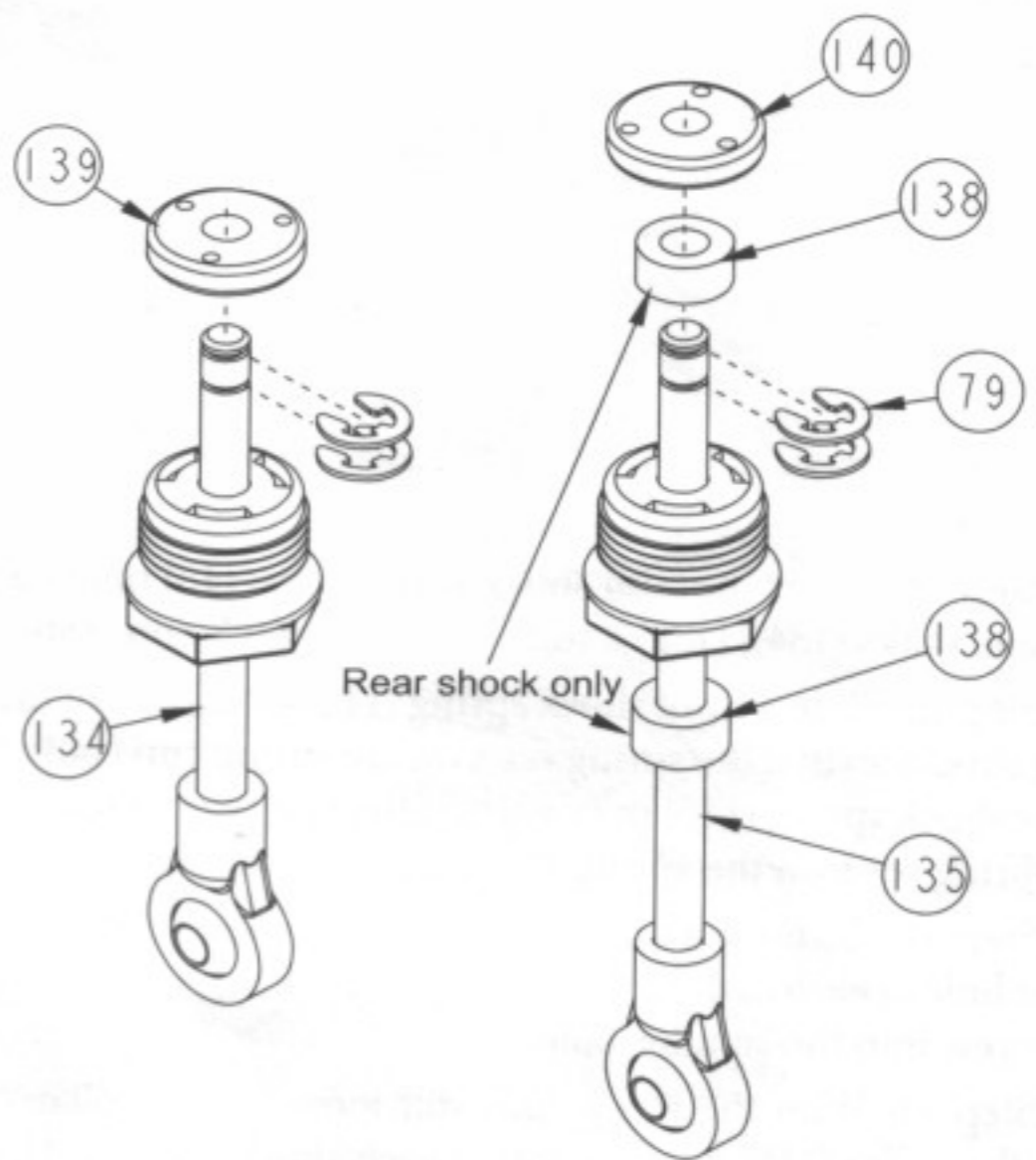


Figure 83

**Figure 84**

❑ Step 13. Match the short, front shock bodies (141) to the short, front shafts (134); and the long, rear shock bodies (142) to the long, rear shafts (135).

❑ Step 14. Fill the shock body (141), (142) with shock fluid (133) up to the bottom of the threads.

❑ Step 15. Insert the shaft assembly into the shock body (141), (142) with the cartridge against the shock piston (139), (140). Slowly tighten the cartridge approximately two full turns. With the cartridge still slightly loose, slowly push the shock shaft (134), (135) into the shock body (141), (142). This will bleed the excess fluid out of the shock. Once the shaft (134), (135) is all the way in, tighten the shock cartridge the rest of the way by hand.

\*NOTE: Be sure to match the short, front shock shafts with the short, front shock bodies.

❑ Step 16. With the shaft (134), (135) still all the way in, secure the cartridge by tightening it with pliers approximately an additional 1/8 turn. There should be no air in the shock as you push the shaft (134), (135) in and out. If there is, the shock needs more fluid. If the shock does not compress all the way, the shock has too much fluid.

\*NOTE: If leaking persists around the outside of the cartridge, tighten the cartridge more.

❑ Step 17. Repeat steps 14 through 16 for all four shocks.

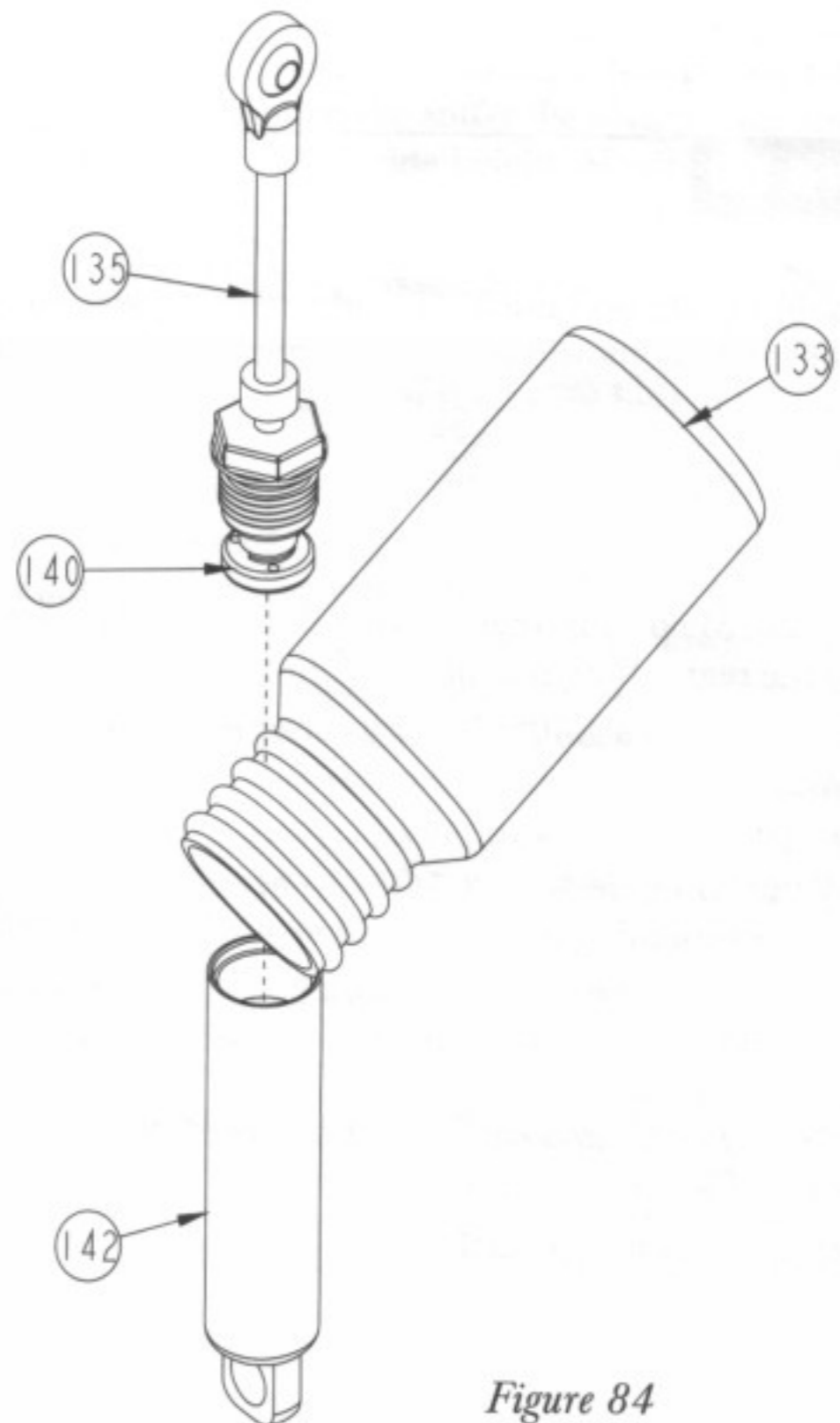
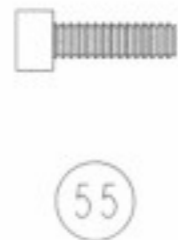


Figure 84

# BAG F (Continued)

**Figure 85**



- ❑ Step 18. Snap a bottom shock spring cup (143) onto each of the four shafts (134), (135) and around the shock end (136).
- ❑ Step 19. Slide a front shock spring (144) over each of the two front shocks so that the spring rests on the spring cup (143). Slide a rear shock spring (145) over each of the two rear shocks so that the spring rests on the spring cup (143).
- ❑ Step 20. Insert a 4-40 x 3/8" cap-head screw (55) into the larger hole of each of the four shock spring collars (146) and thread the screw into the smaller hole.
- ❑ Step 21. With the screw (55) still loose in the collar (146), slide the collar (146) over the top of each shock body (141), (142) and against the spring (144), (145). Tighten the screw (55) in the collar (146) to hold it in place. *Do not over tighten!*

*\*NOTE: Final adjustment will be made later in the ride height section in the tip section of the manual.*

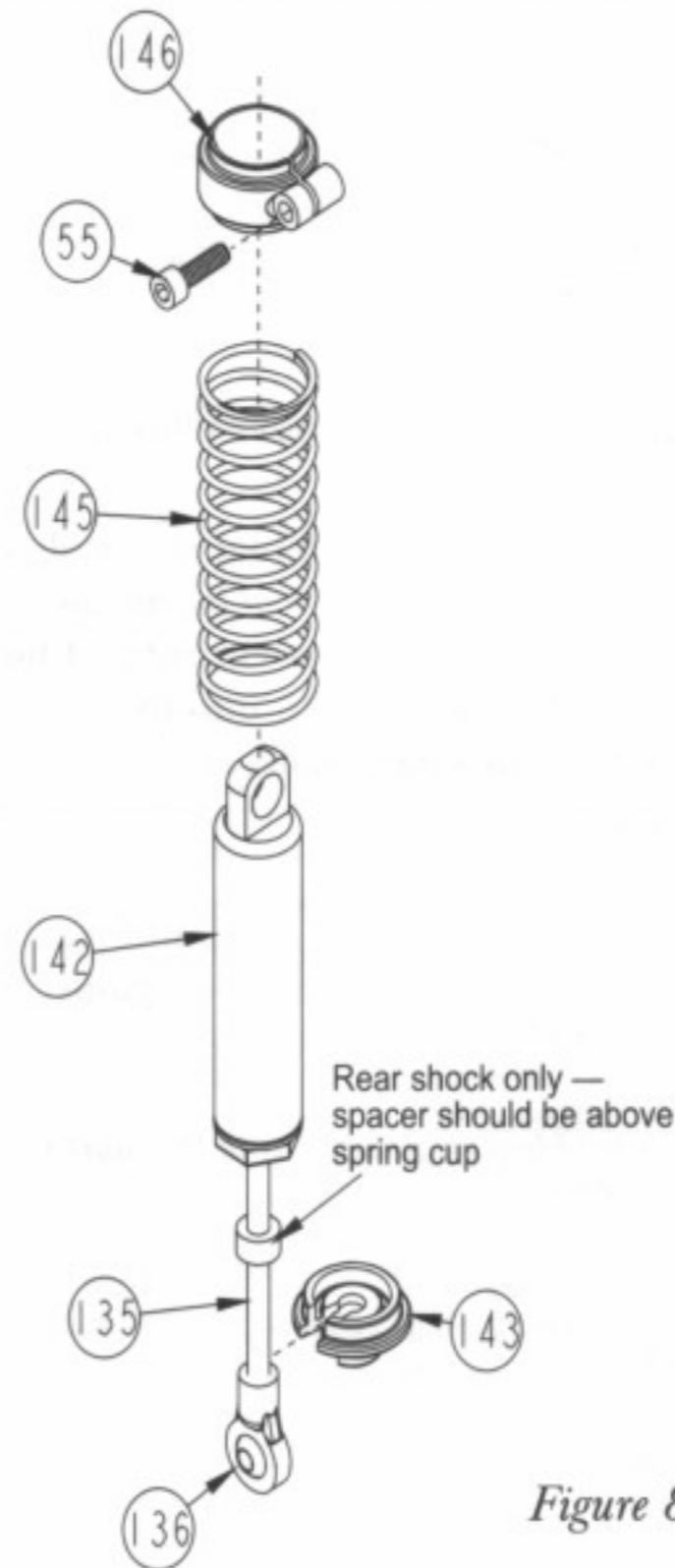
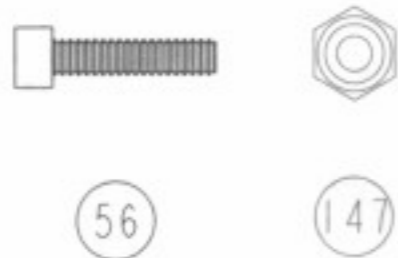


Figure 85

**Figure 86**



- ❑ Step 22. Make sure that the rear dogbones (117) are still in place in the rear differential before continuing.
- ❑ Step 23. Insert a 4-40 x 1/2" cap-head screw (56) in the hole in the swivel ball (137) in the rear shock.
- ❑ Step 24. Attach the bottom of the shock to the rear arm (106), (109) by threading the 4-40 x 1/2" cap-head screw (56) into the inside shock mounting hole on the arm (106), (109).
- ❑ Step 25. Place the top of the shock body (142) over the shock mount bushing (86) on the rear shock tower (110) and secure it with a 4-40 locknut (147).

*\*NOTE: Before attaching the top of the shock, make sure that the dogbone is in place in the outdrive.*

- ❑ Step 26. Repeat steps 23 through 25 for the second rear shock.

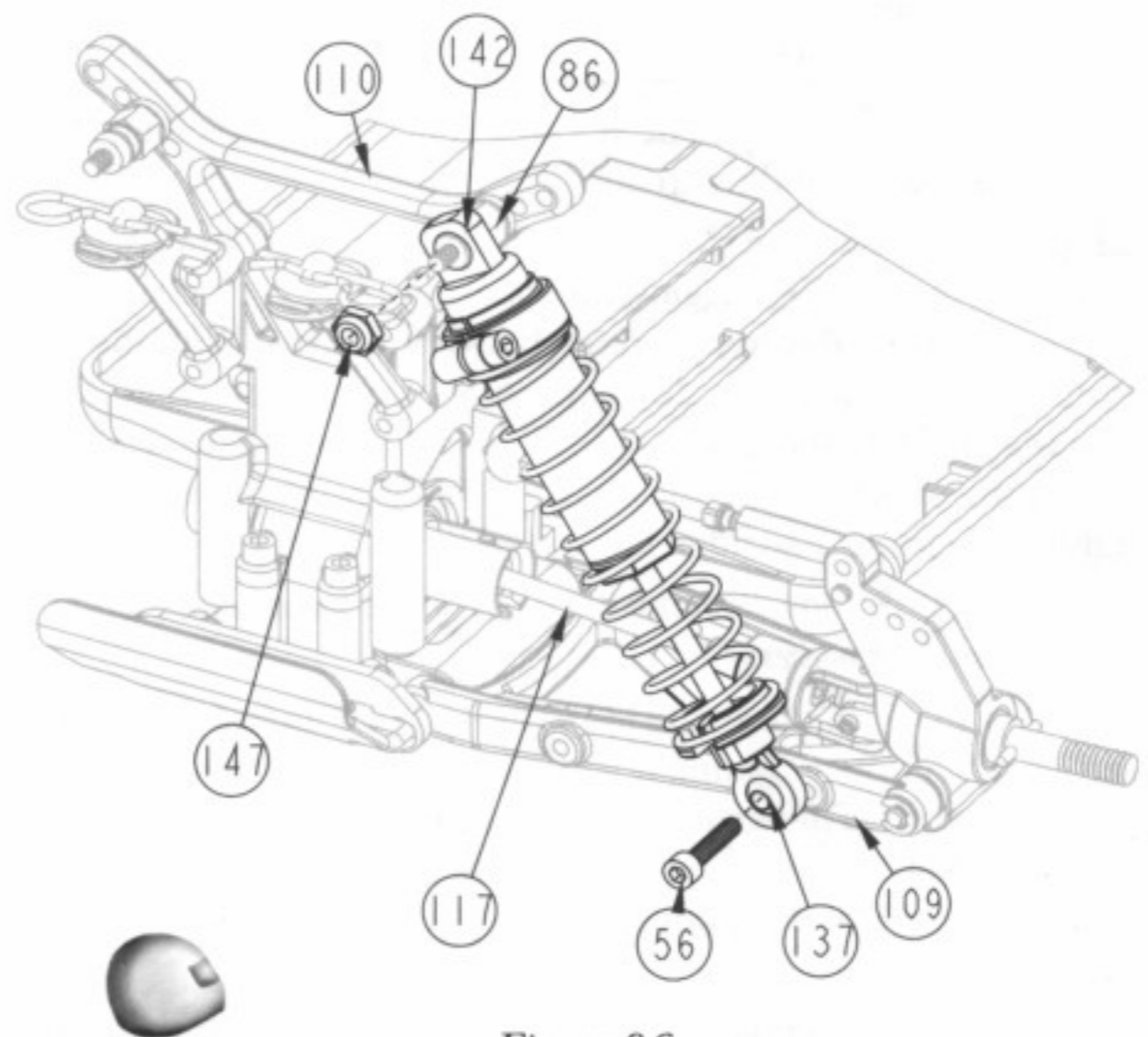


Figure 86

# BAG F (Continued)

**Figure 87**

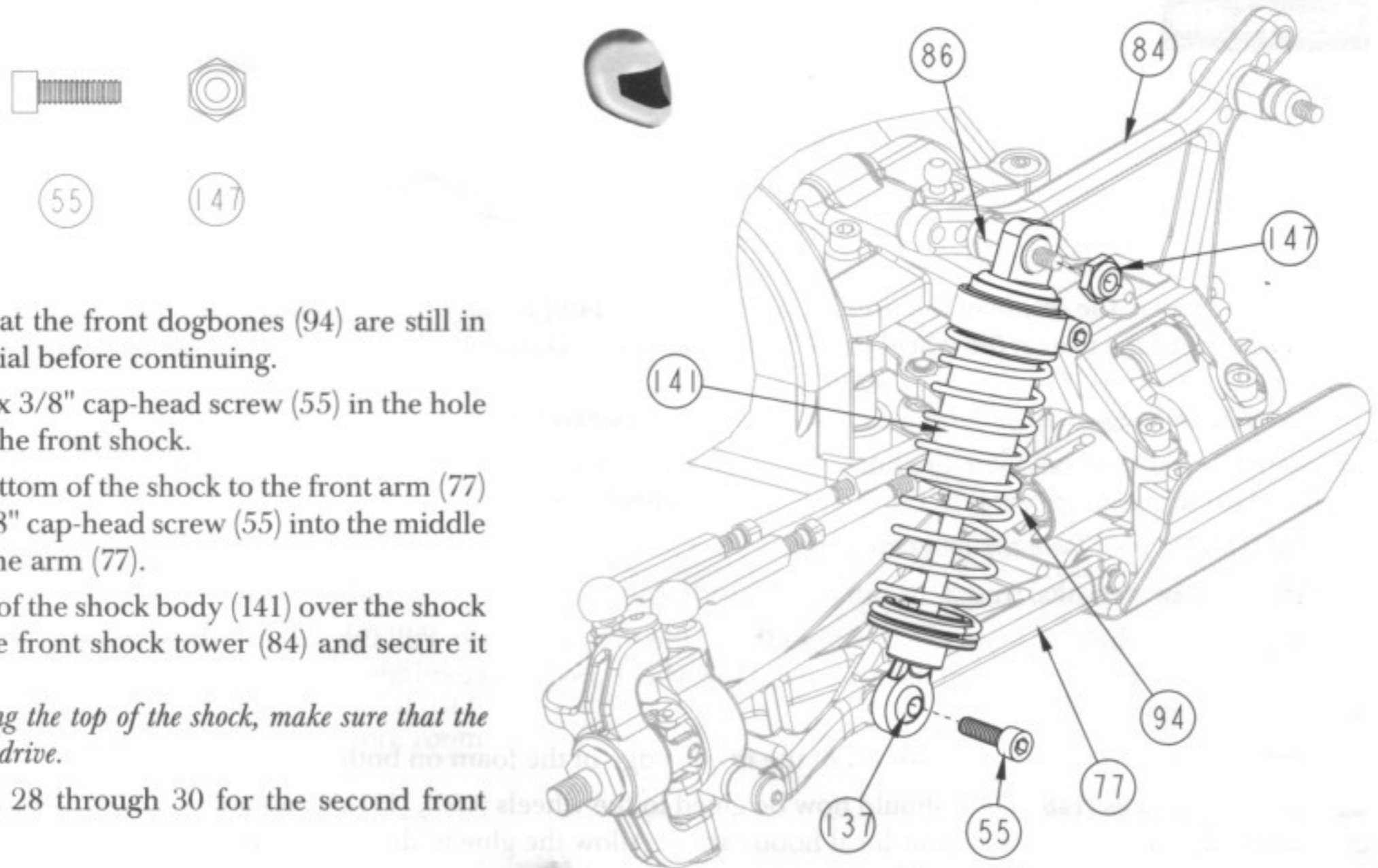


Figure 87

- ❑ Step 27. Make sure that the front dogbones (94) are still in place in the front differential before continuing.
- ❑ Step 28. Insert a 4-40 x 3/8" cap-head screw (55) in the hole in the swivel ball (137) in the front shock.
- ❑ Step 29. Attach the bottom of the shock to the front arm (77) by threading the 4-40 x 3/8" cap-head screw (55) into the middle shock mounting hole on the arm (77).
- ❑ Step 30. Place the top of the shock body (141) over the shock mount bushing (86) on the front shock tower (84) and secure it with a 4-40 locknut (147).

*\*NOTE: Before attaching the top of the shock, make sure that the dogbone is in place in the outdrive.*

- ❑ Step 31. Repeat steps 28 through 30 for the second front shock.

## Understanding shock adjustments

There are endless combinations in which the shocks can be adjusted. You have the ability to change the springs, oil, and pistons. They can be changed independently, or all at once.

The springs are the simplest to understand. This is especially true since all Team Losi springs are labeled with a pound rating so that you know exactly how soft or firm a particular spring is. Basically, the higher the number, the stiffer the spring. One thing to keep in mind when working with springs is that the spring collars should only be used to adjust ride height. Moving the spring collar down, resulting in more pre-load on the spring, is not the correct way to stiffen the spring. If a stiffer spring is desired, then a stiffer spring should be installed.

The oil is also easy to understand since the different viscosities (weights) are labeled on the bottles. Team Losi also produces different sizes of shock pistons. The piston sizes are not quite as easy to understand. Although Team Losi pistons are labeled as to what size they are, what exactly does this mean? This is not one of the easiest things to explain, but I'll do my best to help you understand what happens to the damping of the shock when the piston size is changed.

Let me start by giving you a couple of examples. I'm sure you've experienced the "bubble" test before. This is where you turn a bottle or jar upside down to see how fast or slow the air bubble will travel to the other end. The thicker the fluid, the slower the bubble travels. This is an example of how viscosity works. The thicker fluid has a higher viscosity, which makes the bubble move through it slower. Just the same as a higher viscosity shock fluid makes the piston travel through the shock body slower.

Piston size is a little trickier to explain. I'll give it a shot though. Picture a bathtub full of water. If you were to take a one-foot square sheet of plastic and move it quickly from one end of the tub to the other it wouldn't be easy. This is because the surface of the sheet of plastic would be pushing all of the water around it. If you were to take that same sheet of plastic and drill several large holes in it, the surface area would be greatly reduced. The sheet of plastic could then be moved from one end of the tub to the other much quicker, and with less effort. This is because the water can now pass through the holes as well as around the edges of the sheet. This is an example of something called "pack". Pack is a term used to describe how much resistance there is when a shock sees a quick, sharp movement – such as landing off a jump or hitting a large rut.

Pistons with smaller holes\* in them have more pack, while pistons with larger holes have less pack. Another term you should be familiar with is "static damping". Static damping is the amount of resistance when the shock is moved slowly up and down. Static damping generally affects the handling of the vehicle when entering and exiting corners and in the small "footprint" type holes in a track's surface. Static damping can be adjusted by changing the oil in the shock – regardless of the piston size. Changing to heavier oil will not only increase the static damping, but also increases the pack in the shock. Achieving the right combination of pack and static damping can be tricky. The main advantage of being able to change the size of the piston is the ability to achieve the correct balance of pack and static damping.

*\*Team Losi pistons are packaged as 55, 56, etc. This number designates the drill-bit size of the holes in the piston. Keep in mind that a larger number designates a smaller hole, and a smaller number designates a larger hole.*

# BAG G

Figure 88



154

❑ Step 1. Inspect the inside of the tires [front (148), rear (149)] for any excess material. If present, trim excess rubber to ensure proper seating of the tire on the wheel [front (150), rear (151)]. During tire assembly, make sure that all lettering faces to the outside of the wheel.

*\*NOTE: Do not set tires on furniture as they may leave permanent stains.*

❑ Step 2. Insert the front foam tire liners (152) into the front tires (148). Pull the front tire (148) over the front wheel (150) and squeeze the tire (148) to properly seat it in the grooves of the wheel (150).

*\*NOTE: The front foam tire liners are narrower than the rear tire liners.*

🔧 For best results, trim 3/16" off of the inside edge of the foam on both sides at a 45° angle.

❑ Step 3. Insert the rear foam tire liners (153) into the rear tires (149). Pull the rear tire (149) over the rear wheel (151) and squeeze the tire (149) to properly seat it in the grooves of the wheel (151). Make certain that the foam liners (153) are not pinched between the tires (149) and the wheels (151).

🔧 For best results, trim 3/16" off of the inside edge of the foam on both sides at a 45° angle.

❑ Step 4. The tires (148), (149) should now be glued to the wheels (150), (151). This can be done by using a fast curing superglue or cyanoacrylate glue available at your local hobby shop. Allow the glue to dry thoroughly before continuing.

⚠ **IMPORTANT NOTE:** Read and follow the manufacturers safety warnings regarding the use of any adhesives.

❑ Step 5. Attach the front wheel (150) to the front stub axle (90) by lining up the hex in the wheel (150) with the hex on the axle (90).

❑ Step 6. Apply a small amount of white thrust bearing/assembly grease (49) to the exposed portion of the front axle. Secure the front wheel (150) by threading a 10-32 locknut (154) onto the front stub axle (90), and tightening.

❑ Step 7. Attach the rear wheel (151) to the rear axle (120) by lining up the pin (121) in the rear axle (120) with the groove in the rear wheel (151) and pushing the wheel (151) all the way onto the axle (120).

❑ Step 8. Secure the rear wheel (151) by threading a 10-32 locknut (154) onto the rear axle (120), and tightening.

🔧 Don't overtighten the rear wheels. Doing so may result in a slight bind in the rear axle. Team Losi offers a bearing spacer/wheel washer set (A-9941) that, when installed, allows the rear wheel nuts to be fully tightened.

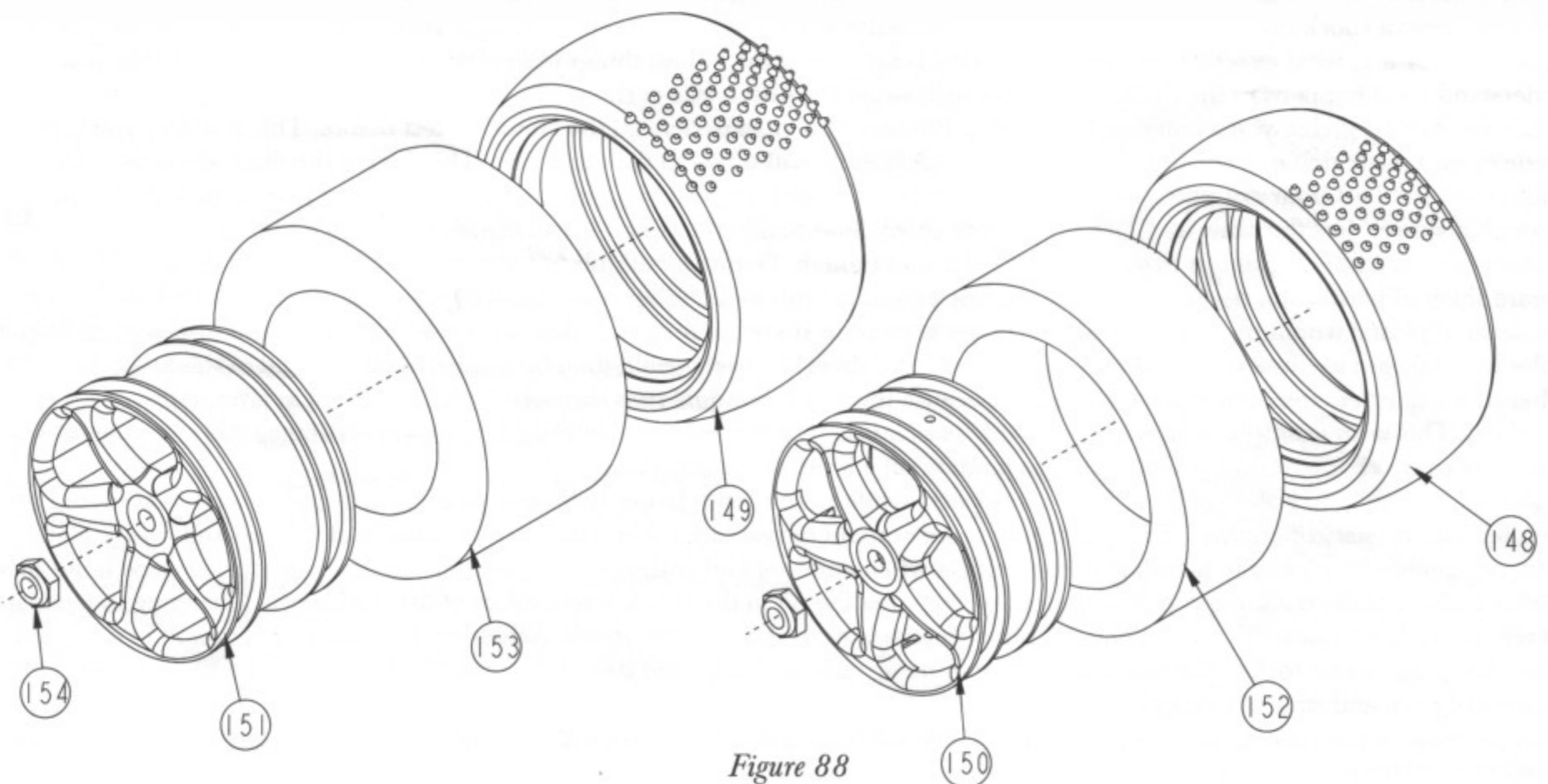
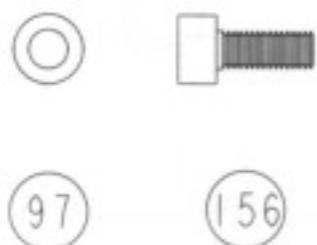


Figure 88

# BAG H

**Figure 89**

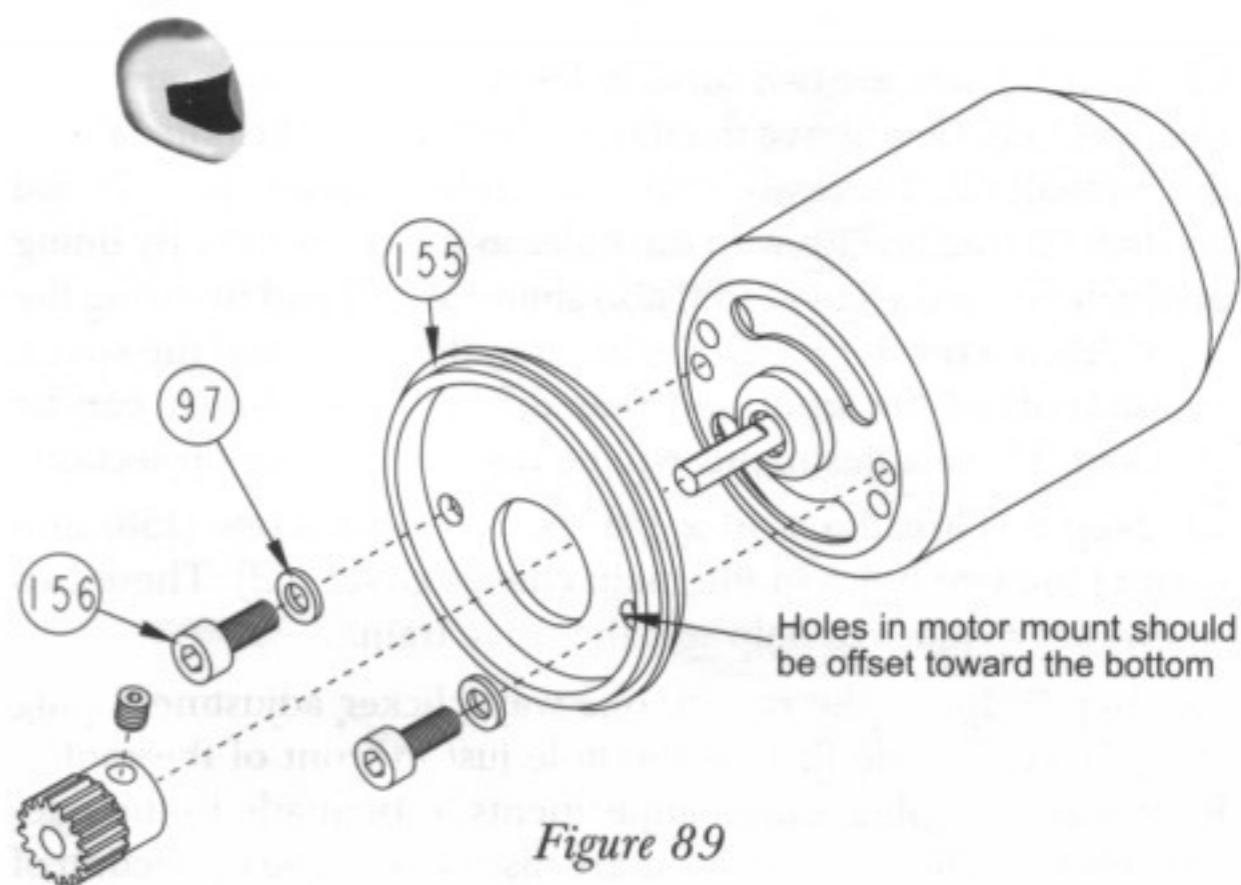


❑ Step 1. Place the motor mount (155) against the motor (*not included*) so that the shaft on the motor is centered in the large hole in the motor mount (155) and the flat surface of the motor mount rests against the motor as shown. Align the holes in the motor mount (155) with the holes in the motor.

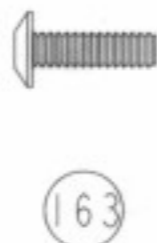
❑ Step 2. Place a ball stud washer (97) over each of the two 3mm x 8mm motor screws (156) and secure the motor mount (155) to the motor by threading the screws (156) through the two holes in the motor mount (155), and tightening.

🔑 If there are two sets of mounting holes in the motor, thread the screws into the set of holes that will allow the motor to be rotated clockwise the farthest (when looking at the motor from the same side as the motor mount). This will allow more room for the motor wires once the motor is installed.

❑ Step 3. Attach the pinion gear (*not included*) to the motor shaft with the tooth section of the gear away from the motor as shown.



**Figure 90**

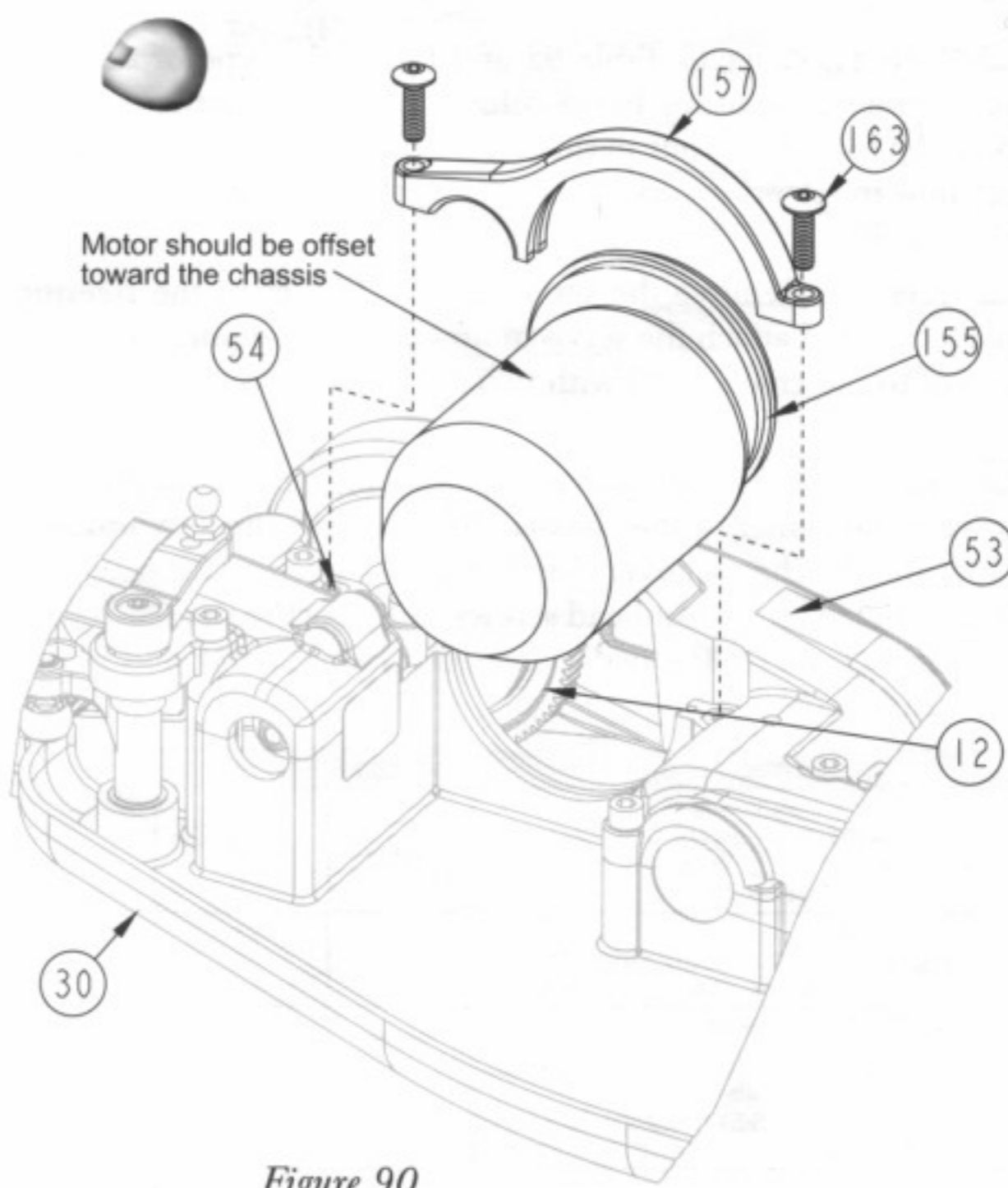


❑ Step 4. Install the motor mount (155), with the motor attached, in the groove in the chassis (30). Check alignment of the pinion gear with the spur gear (12). If the two gears don't align properly, remove the motor and adjust the position of the pinion gear. Check again for proper alignment.

❑ Step 5. Once the pinion gear is properly aligned with the spur gear (12), place the motor mount clamp (157) over the motor mount as shown. Thread a 4-40 x 3/8" button-head screw (163) through the forward hole in the clamp (157), into the threaded insert (54) in the chassis (30), and tighten.

❑ Step 6. Thread a 4-40 x 3/8" button-head screw (163) through the rear hole in the clamp (157) into the threaded insert (54), but **don't tighten** the screw (163) yet. Check the gear mesh through the opening in the side of the cover (53). To adjust the gear mesh, rotate the motor – forward to loosen the gear mesh; and backward to tighten the gear mesh. Once the gear mesh has been adjusted, tighten the rear screw (163).

*\*NOTE: The gears need a small amount of backlash in order to function properly.*



# BAG H (Continued)

**Figure 91**



(158)

❑ Step 7. There are two small holes in the top of the main chassis cover (53): One above the slipper shaft (7) and the other above the layshaft (2). There are also holes in the slipper shaft (7) and layshaft (2) that line up with the holes in the cover (53). By lining up the holes in the cover (53) and shafts (2), (7) and inserting the 1/16" Allen wrench (9) into the holes in the shafts and the cover, adjustments of the front and rear diff, and the slipper can be checked. These adjustments will be discussed in the tip section.

❑ Step 8. Thread a 4-40 x 1/8" button-head screw (158) into each of the two holes in the main chassis cover (53). These two screws act as plugs to help seal the drive train.

❑ Step 9. Insert the round, one-way/clicker adjustment plug (159), bevelled side first, in the hole just in front of the motor. Removing this plug allows adjustments to be made to the one-way/clicker. These adjustments are discussed in the tip section of the manual.

❑ Step 10. Insert the rectangular, gear mesh access plug (160), bevelled side first, in the opening behind the slipper adjustment nut.

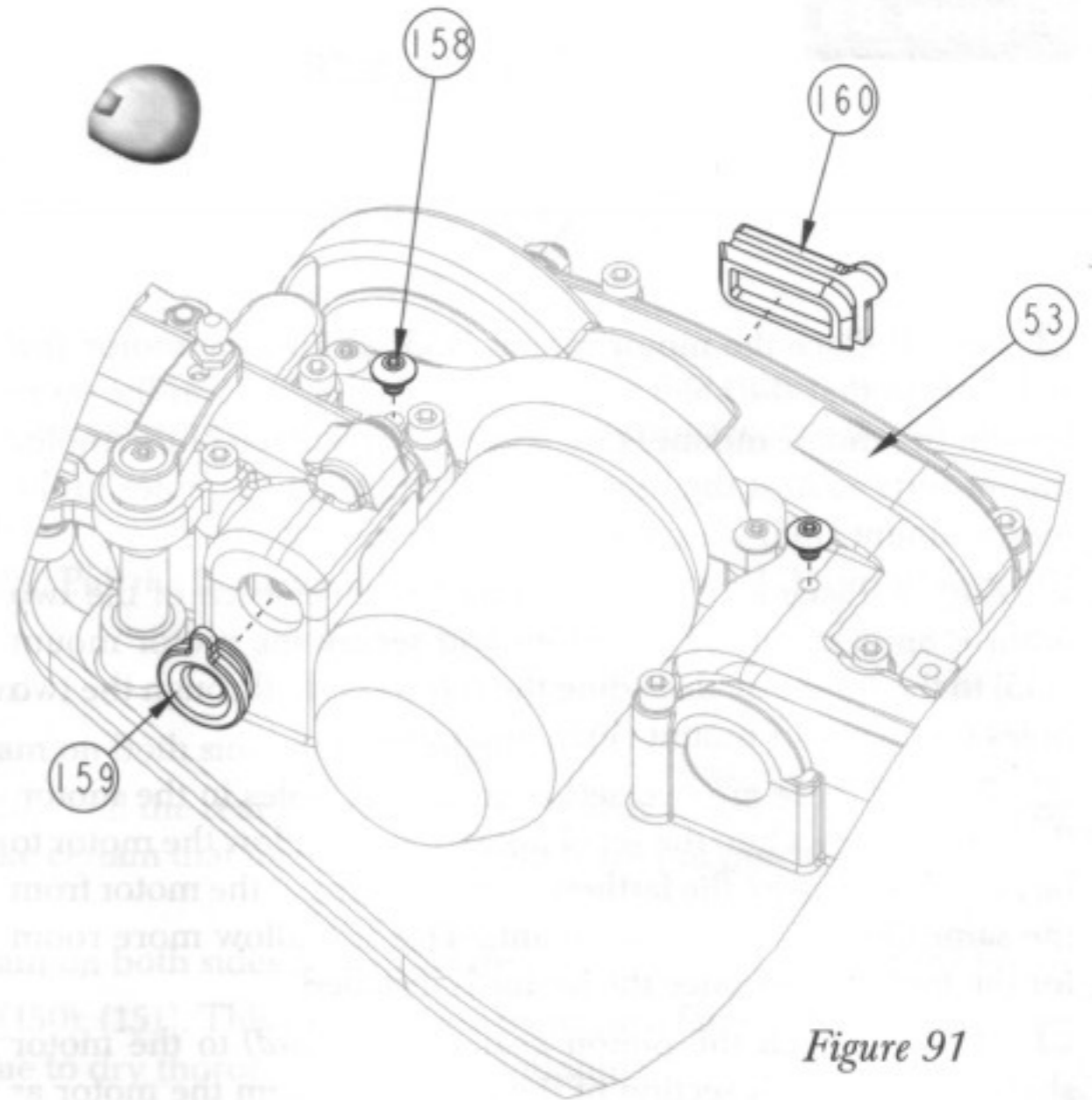
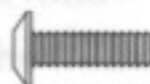


Figure 91

**Figure 92**



(55)

(162)

(163)

❑ Step 11. Refer to Table 92 and locate the type of steering servo you will be using. In the column marked "mount position", note the listing for your particular servo. Refer to Figure 92A to see how the steering servo mount (161) should be attached to the chassis (30).

❑ Step 12. Remove the servo mount (161) from the steering parts tree and attach the servo mount (161) (as required by your servo) to the chassis (30) with two 4-40 x 3/8" cap-head screws (55).

❑ Step 13. Position the servo (*not included*), with the output shaft toward the center of the chassis (30), between the servo mount (161) and the chassis cover (53). Place a #4 washer (162) over the four 4-40 x 3/8" button-head screws (163). Secure the servo with the four screws (163) – two in the servo mount (161); and two in the chassis cover (53).

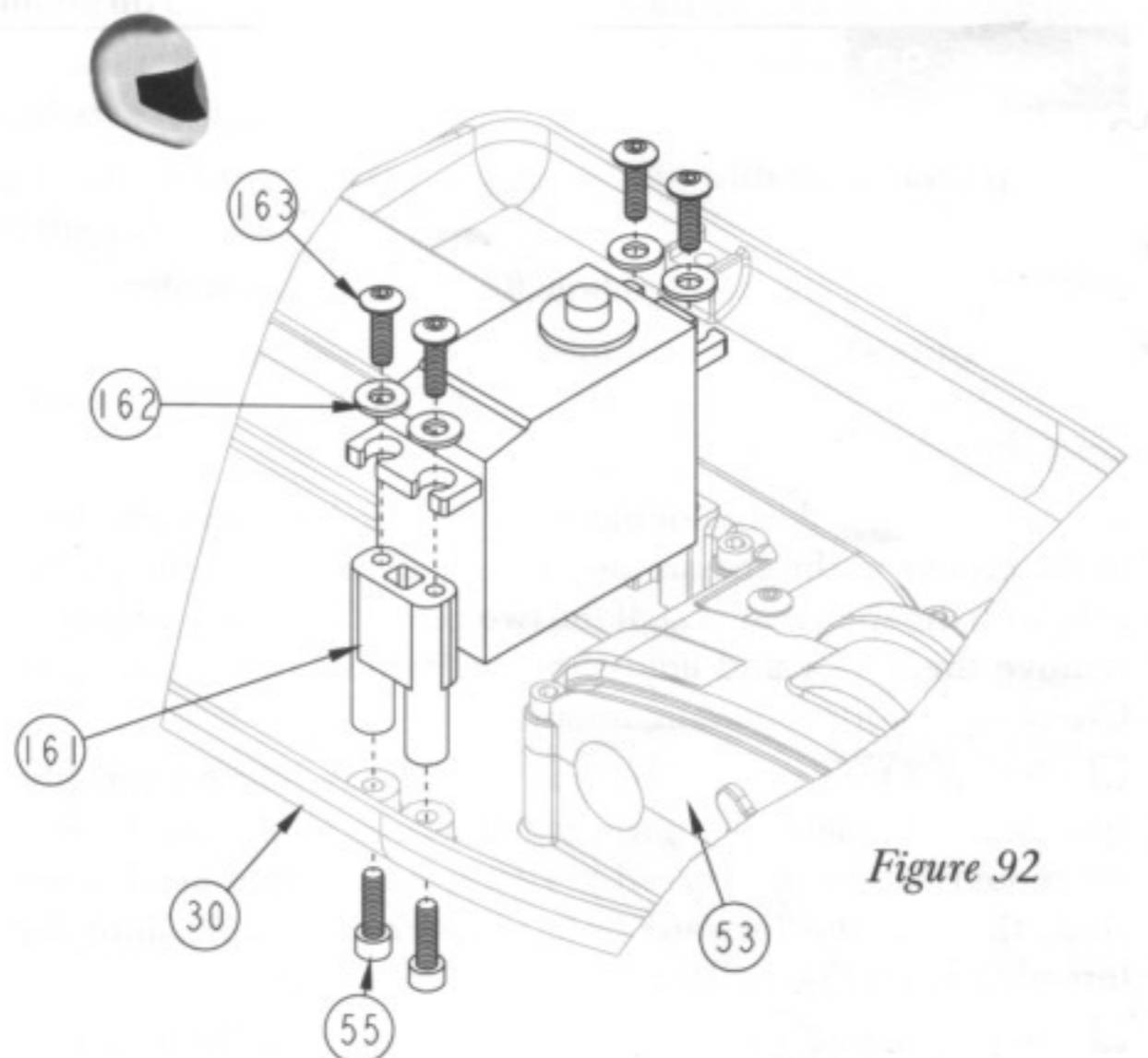


Figure 92

SERVO TYPE	OFFSET	SERVO ARM
Airtronics 94102, 94103, 94141, 94145, 94151, 94152, 94155, 94156, 94322, 94732, 94735, 94737, 94738, 94741	Narrow	23
Futaba S131S, S131SH, S3001, S5101, S9101, S9201, S9301, S9303, S9304, S9401, S9402, S9403	Wide	25
Futaba S132H	Narrow	25
JR NES-507, NES-513, NES-517, NES-901, NES-4000, NES-4131, NES-4721, NES-4735, NES-9021	Wide	23
KO PS-702, PS-703, PS-1001, PS-1003	Wide	23
KO PS-901BH, PS-902	Narrow	23

Table 92

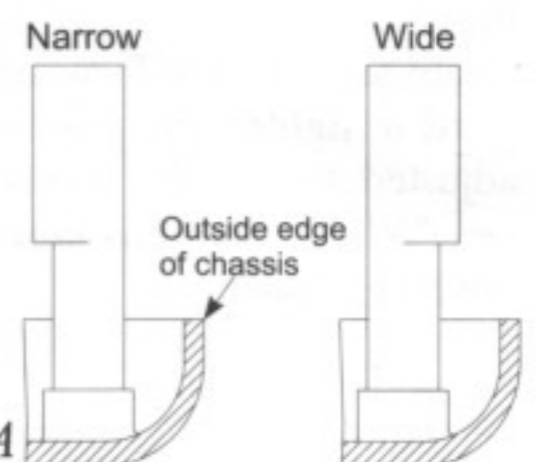


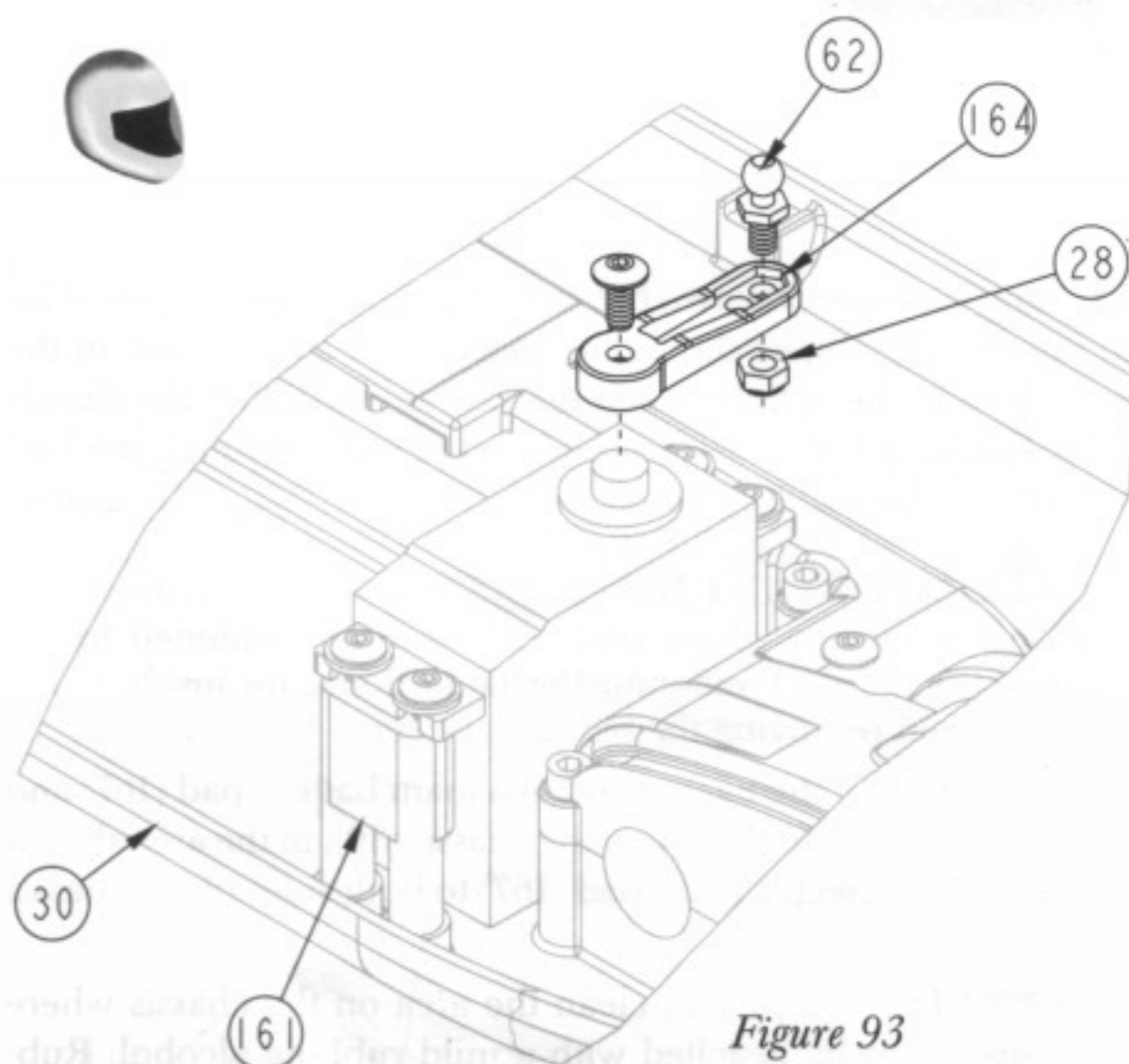
Figure 92A

# BAG H (Continued)

**Figure 93**

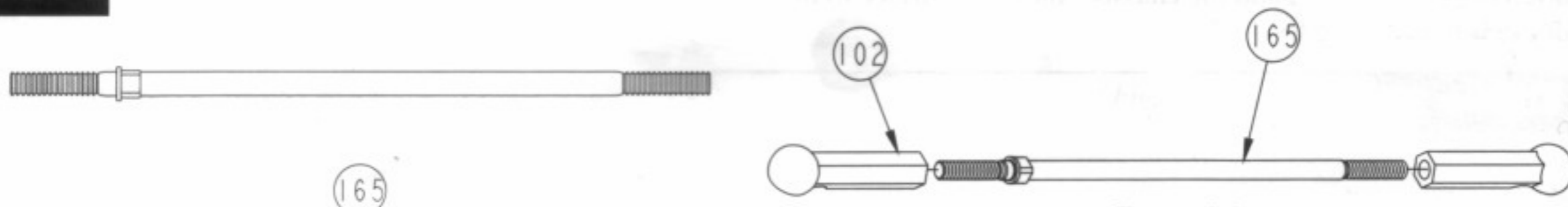


- ❑ Step 14. Refer back to Table 92 to find out which servo arm (164) should be used with your particular servo.
- ❑ Step 15. Remove the servo arm (164), required for your servo, from the steering parts tree. Insert a 3/16" ball stud (62) through the outside hole in the arm (164) and position the hex on the ball stud (62) in the hex area of the arm (164). Thread a 4-40 mini locknut (28) onto the ball stud (62), and tighten.
- ❑ Step 16. Plug the servo into your radio system's receiver. Switch the transmitter on, followed by the receiver. Check to see that the steering trim setting on the transmitter is set to the middle position. With the radio system still turned on, attach the servo arm (164) to the servo so that the arm (164) points straight to the left side of the chassis (30) – away from the servo mount (161). Secure the servo arm (164) to the servo with the servo arm screw supplied with your servo.



*Figure 93*

**Figure 94**



*Figure 94*

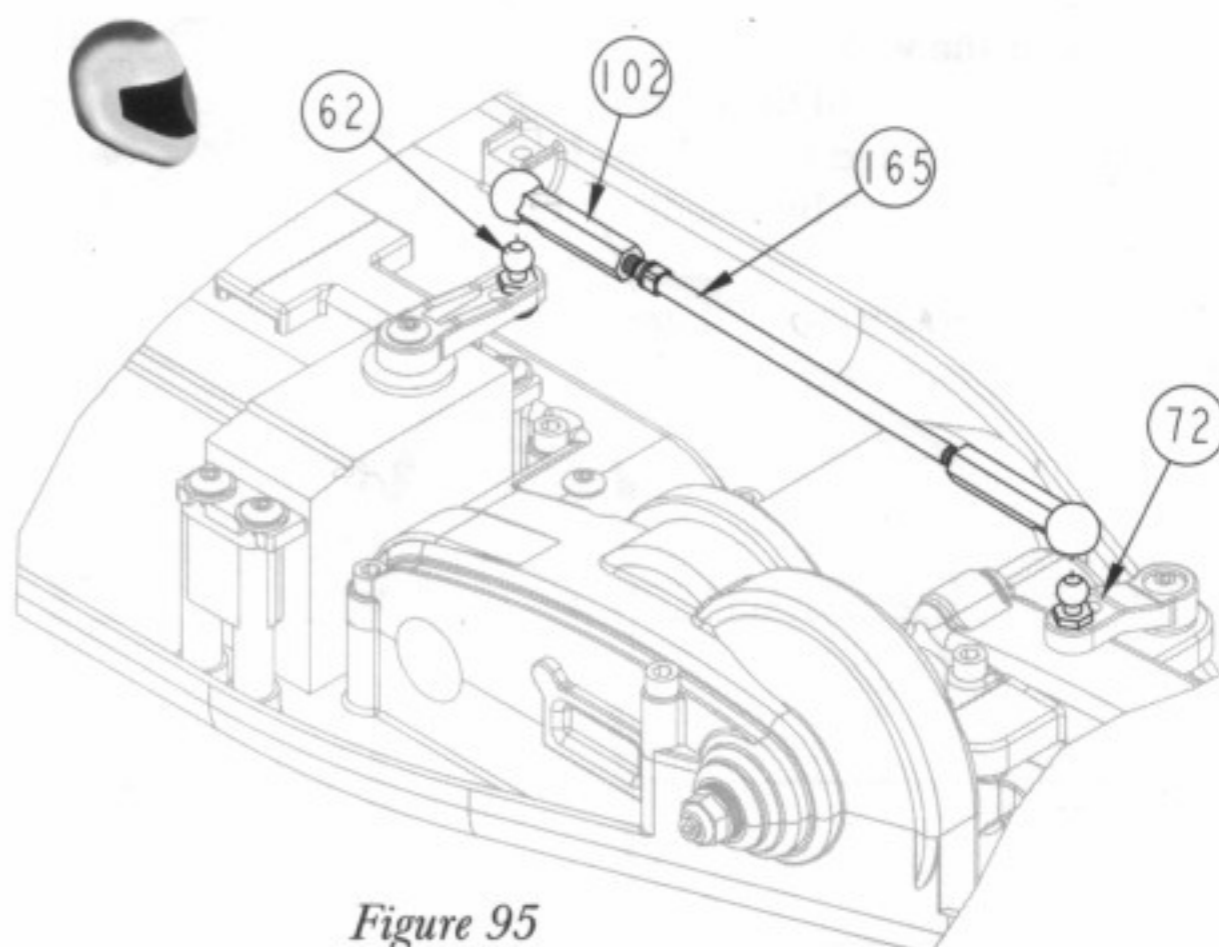
- ❑ Step 17. Thread a plastic rod end (102) onto each end of the steering rod (165). Tighten both rod ends (102) equally until the rod is the same length as the rod in Figure 94A.



*Figure 94A*

**Figure 95**

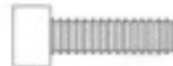
- ❑ Step 18. Attach the rod end (102) at one end of the steering rod (165) to the ball stud (62) in the servo arm (164). Attach the other rod end (102) to the ball stud (62) in the steering bellcrank arm (72).



*Figure 95*

# BAG H (Continued)

**Figure 96**



(55)

❑ Step 19. Attach the two battery strap/body mount posts (166) to the chassis (30), as shown, by placing the square base of the post (166) in the area between the ribs at the side of the chassis (30). Thread a 4-40 x 3/8" cap-head screw (55) through the bottom of the chassis (30), into each of the posts (166), and tighten.

**⚠ IMPORTANT NOTE:** The flat section – on the round platform at the top of the post – should be positioned to the inside of the chassis. Positioning the flat section to the inside makes installing and removing the batteries easier.

❑ Step 20. Peel the backing off of a foam battery pad (167) and stick the pad (167) to the top of the chassis (30), in the area shown in Figure 95. Attach a foam pad (167) to both sides of the chassis (30).

🔧 For best results, clean the area on the chassis where the pads are to be installed with a mild rubbing alcohol. Rubbing alcohol does a very good job of cleaning the area without leaving any lubricants behind. This will ensure a good, strong bond between the pad and the chassis. Allow the surface to fully dry before installing the pad.

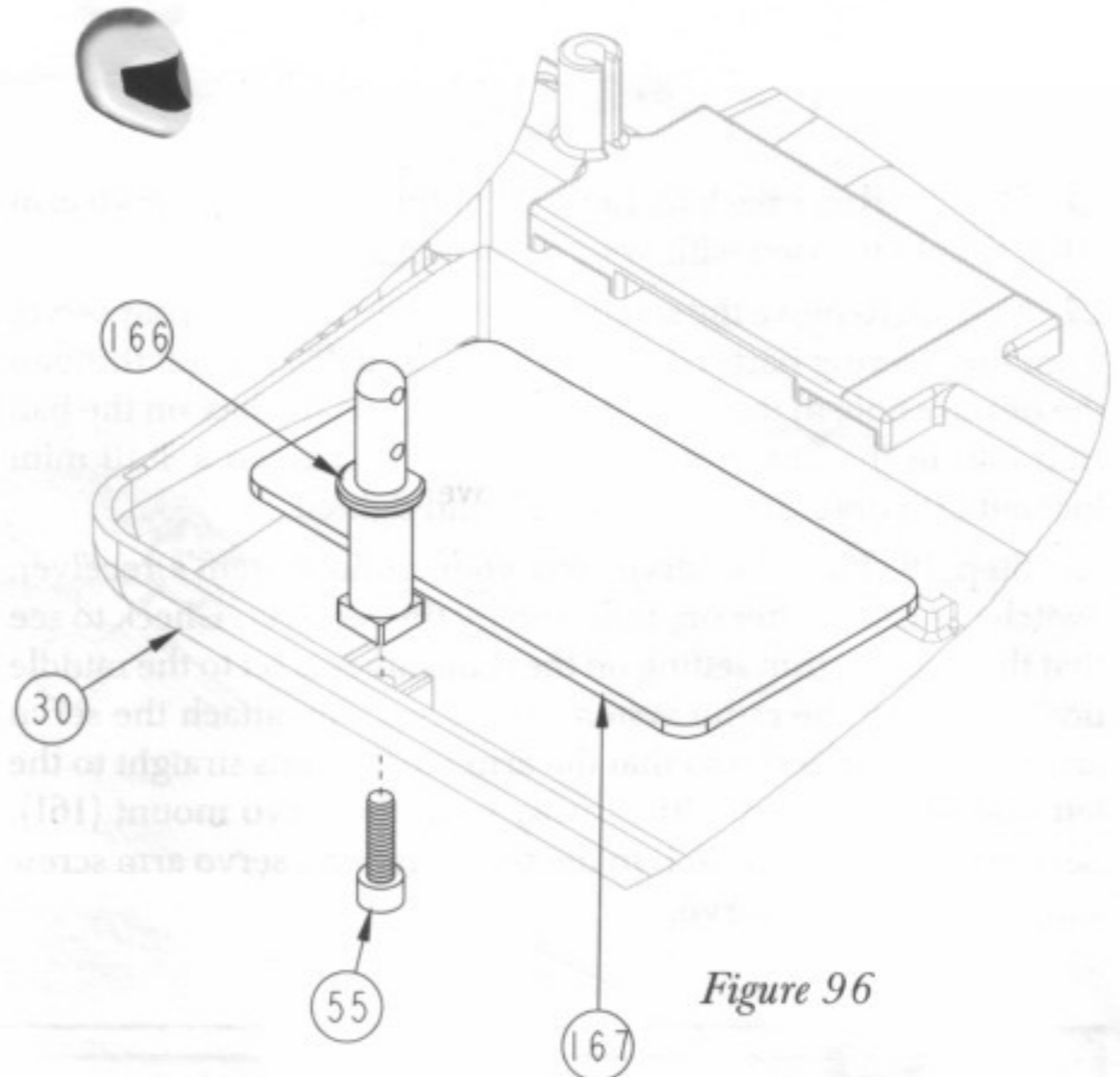


Figure 96

**Figure 97**



(113)

❑ Step 21. Install the battery pack (*not included*) in the chassis (30) as shown. The jumper wire between the two blocks of cells should run over the chassis cover (53), in front of the wide, flat surface as shown.

*\*NOTE: Running the jumper wire to the rear, behind the antenna post will surround the receiver with battery wires which may cause radio interference.*

❑ Step 22. Place the two tabs on the battery hold-down strap (168) under the wide area on top of the chassis cover (53). With the tabs in place, pull the outside of the strap (168) down so the post (166) is inserted through the hole in the strap (168). Secure the strap to the post by installing a body clip (113) in the lower hole in the post (166).

*\*NOTE: See Figures 97A and 97B for a diagram showing battery pack assembly and jumper wire length.*

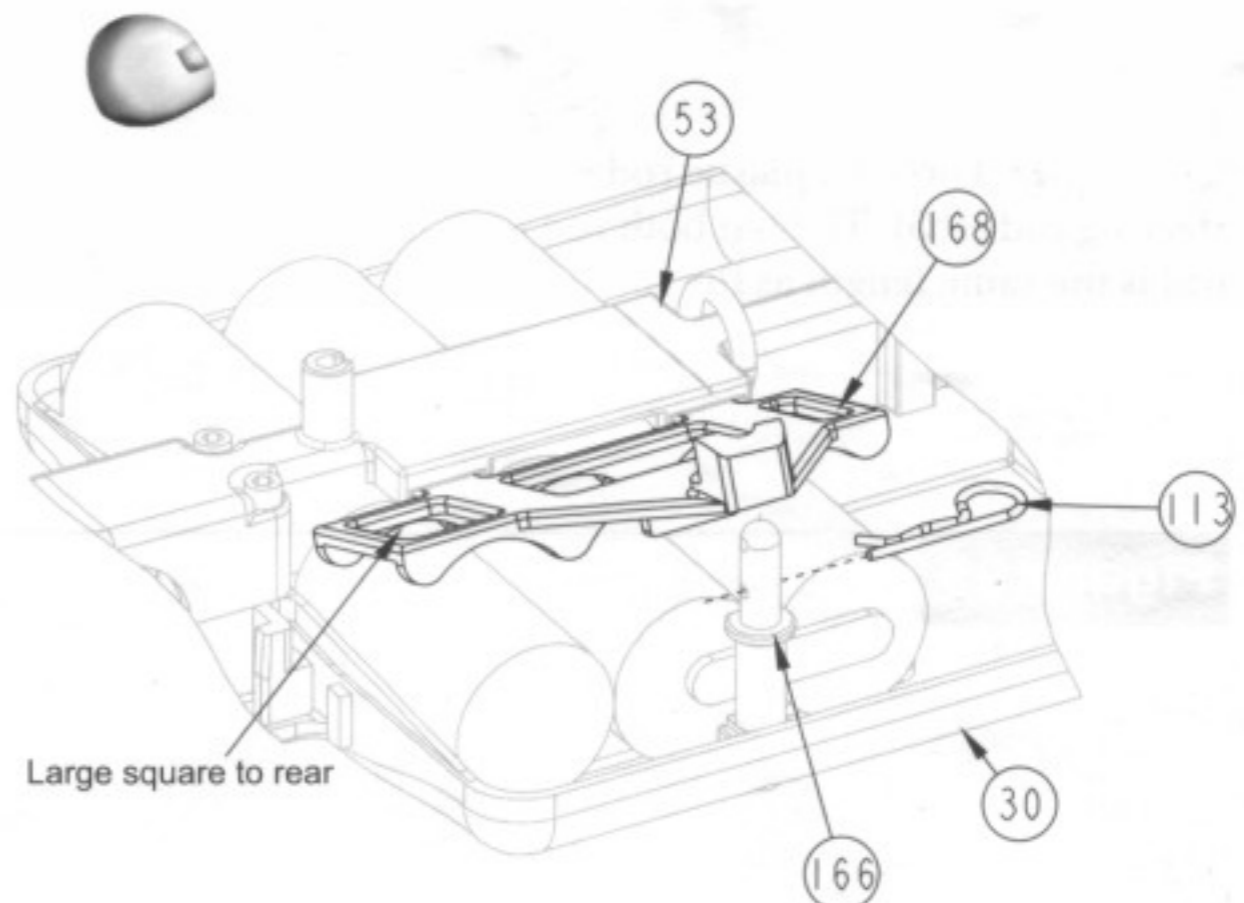


Figure 97

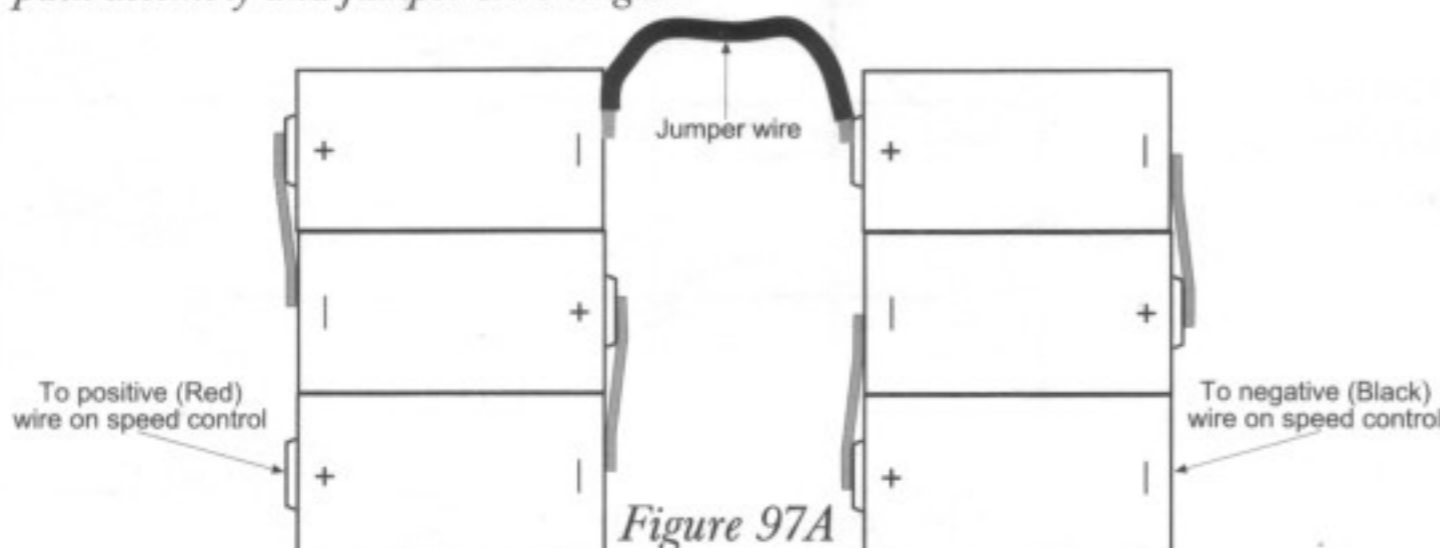


Figure 97A

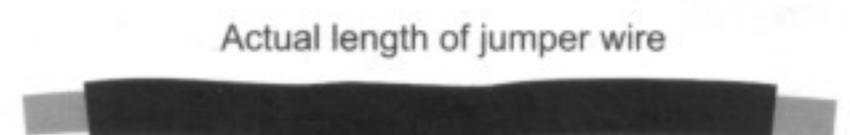


Figure 97B

# BAG H (Continued)

## Figure 98

❑ Step 23. Cut a piece of thick two-sided tape (169) to the same size as the bottom of the receiver (*not included*). Remove the backing from one side of the tape (169) and attach the tape (169) to the bottom of the receiver.

🔑 For best results, clean the surfaces that the two-sided tape will be attached to with a mild rubbing alcohol. This will ensure a good, strong bond. Allow the surface to fully dry before attaching the tape.

❑ Step 24. Remove the backing from the other side of the two-sided tape (169) and attach the receiver to the top of the chassis cover (53) on the wide, flat area between the batteries.

❑ Step 25. Slide the antenna wire, extending from the receiver, through the antenna tube (170) so that the wire comes out the opposite end of the tube (170).

*\*NOTE: A small drop of oil placed in the tube will make the wire slide through the tube easily.*

❑ Step 26. While pulling the wire through the antenna tube (170), press the tube (170) down into the center of the post on top of the chassis cover (53). The wire should be positioned in the slot at the front of the post.

❑ Step 27. Fold the excess wire at the top of the tube (170) down over the tube (170), and place the antenna cap (171) over the tube (170) and wire.

*\*NOTE: If the antenna wire is shorter than the tube, remove the wire from the tube and cut the tube so the wire will extend about 3/4" past the end of the tube.*

❑ Step 28. Using thin two-sided tape (176), attach the speed control (*not included*) to the left side of the chassis (30), between the motor and the battery pack.

*\*NOTE: The drive system of the XX-4 has been optimized for operation in the forward direction. It is recommended that speed controls with reverse not be used.*

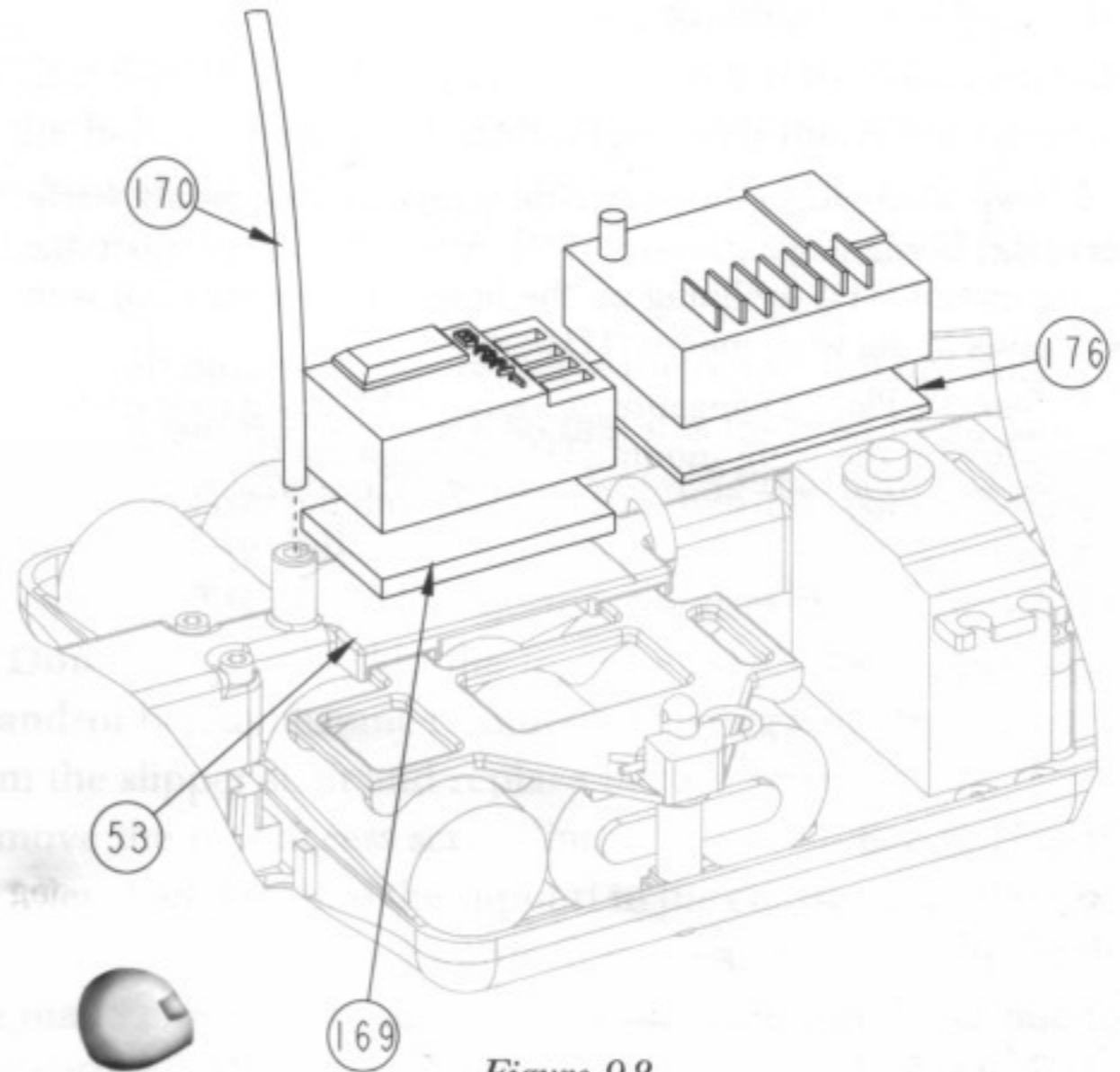


Figure 98

## Figure 99



(113)

❑ Step 29. Trim the body (172) and wing (173) along the trim lines as shown.

❑ Step 30. Make four 3/16"-diameter holes in the areas on the hood, sides, and roof of the body (172) that are marked with dimples or small circles.

*\*NOTE: If the holes are a little tight when installing the body, enlarge them slightly with a hobby knife or round file.*

❑ Step 31. Make two 3/16"-diameter holes in the areas on the wing (173) that are marked with dimples or small circles.

*\*NOTE: If the holes are a little tight when installing the wing, enlarge them slightly with a hobby knife.*

❑ Step 32. Attach the body (172) to the rolling chassis and secure the body with three body clips (113): One through the post on the front shock tower (84); and one through each post (166) at the sides of the chassis (30).

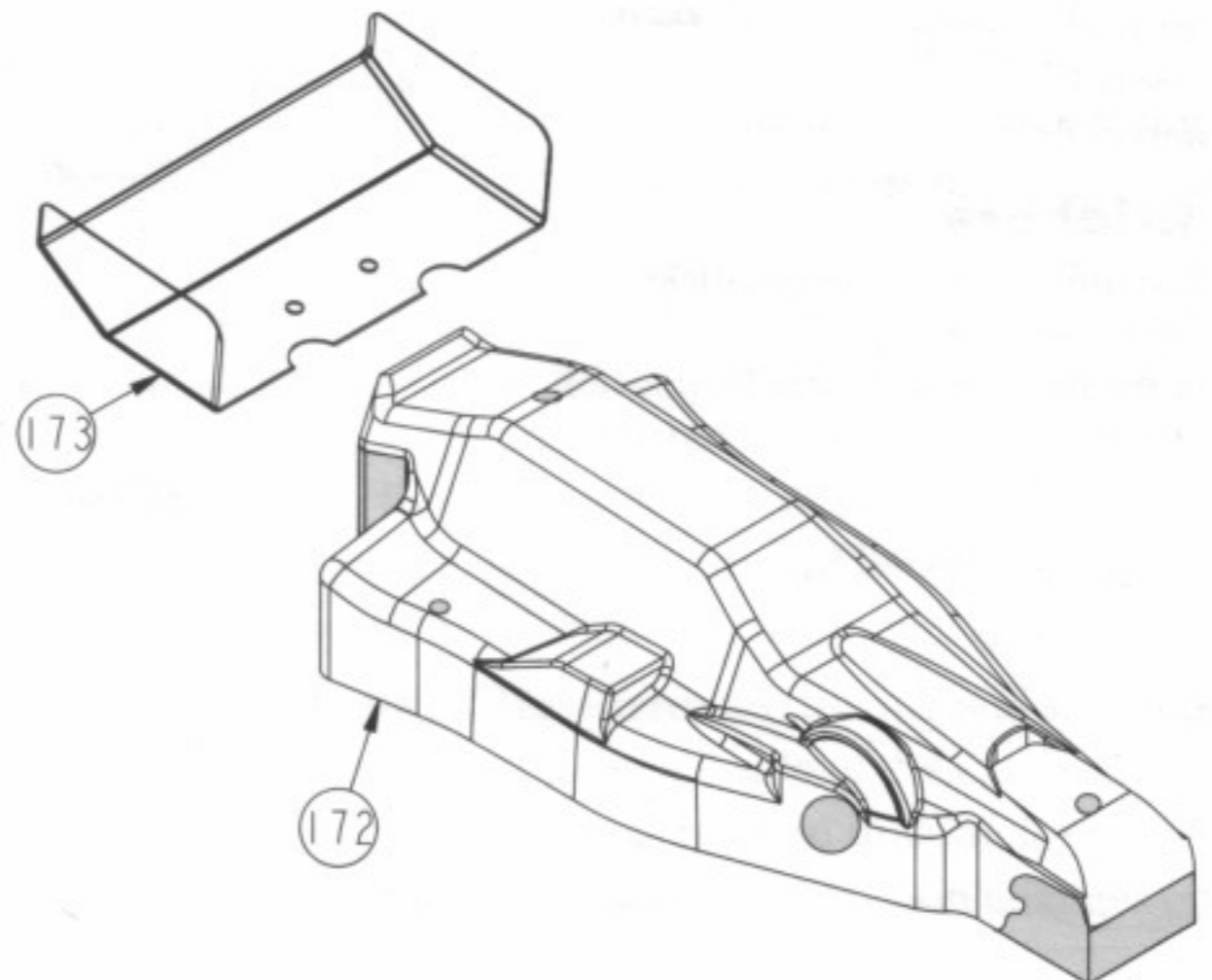
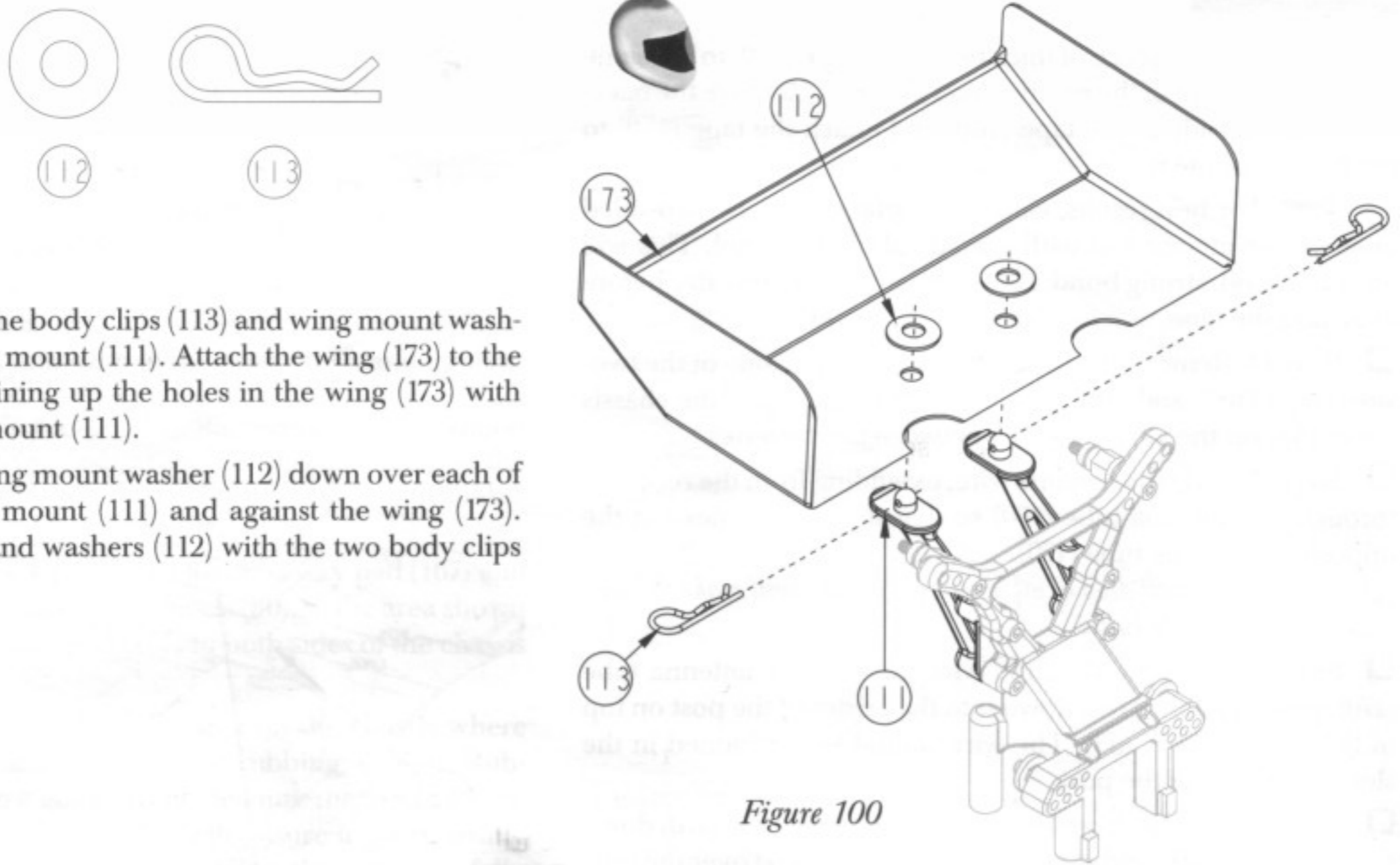


Figure 99

# BAG H (Continued)

**Figure 100**



❑ Step 33. Remove the body clips (113) and wing mount washers (112) from the wing mount (111). Attach the wing (173) to the wing mount (111) by lining up the holes in the wing (173) with the posts in the wing mount (111).

❑ Step 34. Place a wing mount washer (112) down over each of the posts on the wing mount (111) and against the wing (173). Secure the wing (173) and washers (112) with the two body clips (113).

*Figure 100*

## Body and Wing Painting

Prepare the body shell for painting by washing it thoroughly with warm water and a small amount of liquid detergent. Dry the body with a clean, soft cloth. Use the window masks (174), supplied with the kit, to cover the window areas *from the inside*. A high-grade masking tape should be used on the inside of the body to mask off any stripes, panels, or designs that you wish to paint on the body or wing. Use acrylic lacquer, acrylic enamel, or any other Lexan (Polycarbonate) recommended paints. Apply paint to the inside of the body. Remove the tape for the area that you wish to apply the next color to and continue with the next color. Try to use the darker colors first. If you use a light color before a dark color, apply a thin coat of white over the lighter color before continuing with the darker color.

## Stickers

Cut the stickers from the sticker sheet (74) that you wish to use. Before removing the protective backing, find the desired location for the sticker. Remove the backing completely and reattach an edge of the sticker to the shiny side of the backing paper. Using the rest of the backing as a handle, position the sticker over the desired location and press it firmly into place to complete its application.



# TIPS FROM THE TEAM

**ADJUSTING THE DIFFERENTIALS** The differentials should be adjusted before trying to adjust the slipper. To adjust the front differential, remove the forward access screw (installed in step 8, bag H) and insert a 1/16" Allen wrench in the hole. Slowly rotate the front wheels backwards until the hole in the slipper shaft aligns with the Allen wrench. Once the shaft is aligned, insert the Allen wrench all the way through the shaft and into the support in the chassis. With the wrench in place the slipper shaft cannot be turned. Hold both front tires and try to rotate them backwards. If the tires can be rotated easily, the diff is too loose.

To tighten the diff, insert the second 1/16" Allen wrench in the left outdrive. Slowly rotate the right front tire until the slot in the diff screw is aligned with the slot in the outdrive. Position the Allen wrench so that it is inserted in the slot in both the outdrive and the diff screw. Slowly rotate the right tire clockwise about 1/8 turn. Rotating the right tire clockwise with the diff screw held in place by the Allen wrench will tighten the diff.

Check the diff adjustment again as described above. When the diff is properly adjusted, the tires should be VERY difficult to turn. You may actually hear the front belt skip. **Don't** repeatedly skip the front belt with the slipper shaft locked in place. Doing so may cause the teeth on the pulleys and/or belt to become rounded, reducing belt life. Once the front diff is properly adjusted, remove the Allen wrench from the slipper shaft and replace the access screw.

The rear differential is adjusted in a similar fashion. Remove the rear access screw (installed in step 8, bag H) and insert the Allen wrench into the hole, through the hole in the idler shaft, and into the support in the chassis. Turn the rear tires slowly backwards. When checking the rear diff, the tires must be turned backwards or the rear belt will skip while trying to check adjustment. Adjustments to the rear diff are made exactly the same way as the front diff. Continue to tighten the rear diff until the rear tires are very difficult to turn with the Allen wrench inserted in the idler shaft. Once the rear diff is properly adjusted, remove the Allen wrench from the idler shaft and replace the access screw.

**SLIPPER ADJUSTMENTS** should be made only after both the front and rear diffs are properly adjusted. The slipper adjustment that this manual recommended during assembly should be fairly close. The slipper is designed with a separate pad for the front and rear wheels. The slipper adjustment can be checked in a similar way to checking the diff adjustment. When the Allen wrench is inserted in the slipper shaft (forward hole), the rear slipper can be checked. Again, only rotate the rear tire backwards when the Allen wrench is inserted in the slipper shaft. There should be resistance, but you should be able to rotate the rear tires. The resistance you feel is the slipper. The tighter the slipper adjustment, the more resistance.

The front slipper adjustment can be checked by inserting an Allen wrench in the idler shaft (rear shaft) and rotating the front tires. Again, the resistance you feel is the slipper. You should always be able to rotate the tires when checking the slipper adjustment. The slipper needs to be able to absorb the jolts that the drive train encounters due to bumps and jumps on the track.

As a final check of the slipper adjustment, place your car, with a fully-charged battery, on a carpeted area. Give the car full throttle from a stopped position. The slipper should slip slightly (about 1-2 feet). If the slipper does not slip, loosen the slipper nut 1/8 turn and check again. It is important that the slipper not be adjusted too tight! If the slipper does not slip when the car encounters bumps and ruts, extra wear-and-tear to the drive train will result.

The slipper pads will seat and break in after 3-4 runs. This usually results in the slipper adjustment becoming tighter. At this point the slipper adjustment should be checked again. Loosen the slipper as necessary so that it will slip slightly.

**THE ONE-WAY/CLICKER** allows the front wheels to free-wheel when off power. This increases steering and smooths the car's handling under braking. The clicker can be adjusted through the access plug on the left side of the car. Tightening the nut will reduce the amount of free-wheeling. A tighter adjustment will result in an increase in braking force, but usually a slight loss in steering. The one-way/clicker adjustment can be very useful as the amount of traction changes on a track.

**THE BELTS** on the XX-4 are a result of extensive research and testing. They are made from the best materials to optimize both efficiency and life-expectancy. It is very important that you do not allow motor spray to come into contact with the belts on the XX-4. If the belts are exposed to motor spray, the materials will break down – resulting in damage to the belt.

**TIRES**, as always, play an important part in the way the car handles. Naturally, the more traction a tire has, the easier the car is to drive. Be careful! It is possible to have too much front traction with a 4WD car. If the front tire has too much traction, the car will become very "darty" and hard to drive. In extreme cases the car may even traction-roll.

With 2WD cars, front and rear tires can be used in any combination. With 4WD cars this isn't always true. You should always try to use a similar tires on both the front and rear. More importantly, the front and rear tires should be the same diameter. If the front and rear tires are different diameters, the front and rear drive ratios will differ. Having different drive ratios in the front and rear can make the car handle unpredictably. To further explain, if the front tires are larger than the rear tires, the front-wheel-drive will have less acceleration and more top-end speed than the rear-wheel-drive. If the front tires are smaller than the rear tires, the front-wheel-drive will have more acceleration and less top-end speed than the rear-wheel-drive.

**THE BATTERY PACK** in the XX-4 can be mounted in two locations. The standard mounting location (referred to in the manual) is to the rear of the chassis. By simply rotating the battery straps, the battery can be mounted farther forward in the chassis. Mounting the battery farther forward can increase steering at the cost of a slight reduction in rear traction. This can be a useful adjustment on certain track surfaces.

**THE CHASSIS** of the XX-4 is made of Team Losi's exclusive Stiffezel material. This material is very stiff and relatively lightweight. The high fiber content of the chassis makes it slightly conductive to electricity. It is very important that the heat-shrink on the battery cells be checked periodically. If an exposed portion of the cell makes contact with the chassis, the battery pack may short out or radio interference may result. The battery pads on the chassis should also be replaced from time-to-time to reduce the risk of the battery pack shorting out on the chassis. It's also a good idea to apply a piece of electrical tape to the sides of the chassis and chassis cover in the area where the jumper wire and battery bars may touch.

Due to the very low motor placement in the XX-4, care should also be taken not to allow any capacitors or motor tabs to touch the chassis. Radio interference may again be the result of contact here. A piece of electrical tape under the area where the motor mounts is a good insurance policy.

**REAR ANTI-SQUAT** on the XX-4 is adjustable. Anti-squat adjustments can be made by installing the small wedges (referred to in figure 70) under the rear suspension mounts. Installing the wedge under the front portion of the suspension mount will increase anti-squat. Installing the wedge under the rear portion of the suspension mount will decrease anti-squat. The rear suspension mounts have two degrees of anti-squat built into them. Installing a wedge under the front portion of the mount will increase the anti-squat to four degrees and installing the wedge under the rear portion will result in zero degrees of anti-squat.

Typically, a higher degree of anti-squat will result in quicker acceleration and a loss of on-power steering. A lower degree of anti-squat will have more on-power steering, but will accelerate slightly slower. More anti-squat will help the car go through bumps better when already at full speed. Less anti-squat will accelerate through bumps better.

**CAMBER** in the front end of the car is not really adjusted much. In the front, run between one and two degrees of negative camber at ride height. A general rule of thumb is that more negative camber will help the car go through bumps in turns a little more consistently. Less negative camber can make the car respond quicker on some tracks with hard-packed surfaces.

Rear camber is used to help the car drive through bumps in corners a little better. Generally, run between one and three degrees of negative camber at ride height. More negative camber will make the car drive through bumps better, but you will usually lose a little straight-line rear traction.

**FRONT TOE-IN and TOE-OUT** are fully adjustable by changing the length of the tie rods. When adjusting toe-in, be sure to adjust both tie rods equally so that the steering balance from left to right will remain the same. Toe-in makes the car a little easier to drive, and will make the car more neutral feeling. Too much toe-in can make the car feel "wandery" when exiting corners. Toe-out will make the car turn into the corner faster, but can cause oversteer. It is recommended that you run the front toe-in/toe-out as close to straight as possible.

**FRONT RIDE HEIGHT** is an adjustment that can change the way a car jumps, turns, and goes through bumps. This is an adjustment that can vary from track to track. You should try raising and lowering the front ride height to get a feel for what it does to the handling of the car. The front ride height should initially be set so that the dogbones are level at ride height. To set the ride height, drop the front of the car onto a table from about 2-3 inches above the table. Lightly "work" the front suspension up and down. This will "settle" the front suspension at its natural ride height. Working the suspension becomes important as the parts start to get dirty and worn from running. Once the suspension has settled, the dogbones should be level. If the front end is either too high, or too low, adjust the spring collars accordingly and check the ride height again as described above. Continue this procedure until the front ride height is adjusted to the desired location.

**REAR RIDE HEIGHT** can change the way a car turns, the amount of traction a car has, and the way a car goes through the bumps. Again, it is a good idea to play with this adjustment and get a feel for it. For most conditions, the rear ride height should be set so that the dogbones are level with the ground. Adjust the rear ride height in the same way as described in the front ride height section.

**CAMBER LOCATIONS** on the XX-4 are very adjustable. Although there are many holes to choose from, it is suggested that the locations in the manual be used. We have done extensive testing with all of these locations both on the track, and on special computer programs, and have found the locations in the manual to be *very consistent* from track to track. These locations should produce the best all-around setup and work under most conditions.

**THE WING** is marked with scribe lines that will allow it to clear the rear shocks in their standard mounting position. If you move the rear shocks to a different location, make sure that the wing is trimmed so that the rear shocks will clear it.

**MAINTENANCE** on the XX-4 is quite simple. We have found certain sequences that make accessing different parts of the XX-4 very easy. If the front differential needs to be removed, start by removing the front bumper. Take the two screws out of the bottom and the two screws out of the top. Disconnect the bottoms of the shocks from the front arms. Disconnect the outside of the tie rods and camber links. Remove the front two screws from the front shock tower that go down into the front bulkhead. Turn the car over and remove the two screws holding the front bulkhead in place. Remove the front bulkhead with the suspension arms attached. The front diff should now be accessible.

To get to the rear diff, rear belt, spur gear, or idler shaft, first remove the rear bumper. Remove the four screws from the bottom of the rear suspension. With the screws removed, the rear suspension can be removed – shock tower, arms, and all. Remove the motor from the car. Turn the chassis over and remove the two screws at the front and rear of the motor mount area. Remove the two screws in the bottom of the servo mount. Turn the chassis right-side-up and remove all the screws from the main chassis cover (nine total). Unplug the speed control from the receiver and remove the gear mesh plug. Remove the chassis cover with the receiver and servo still attached.

To access the front belt or slipper shaft, follow the same sequence just mentioned and continue by removing the front shock tower. Once the front shock tower is removed, take out the clicker access plug and remove the front belt cover. To remove the front belt, the steering tunnel must also be removed.

When reassembling the car **don't forget** to put the screws back into the threaded inserts from the bottom of the chassis. If these screws are not installed, the motor may move while running the car, resulting in a damaged spur gear. Also, don't forget about the rubber access plugs and allow them to fall in the enclosed part of the chassis. If one of these plugs gets into the belts while running – well, do I even need to tell you what will happen?

Good luck with your new XX-4. We're sure you will be pleased with its superb performance.

# SPARE PARTS LIST

KEY #	KIT/PART DESCRIPTION	PART NO.	SPARE PARTS DESCRIPTION
1	.078" x 3/8" spirol pin	A-3225	Layshaft with Hardware (4WD)
2	Layshaft	A-3225	Layshaft with Hardware (4WD)
3	Large (42T) 2mm belt pulley	A-3210	Drive and Differential Pulley Set (4WD)
4	3/16" C-clip	A-6102	C-Clips 3/16"
5	Small (17T) 3mm belt pulley	A-3210	Drive and Differential Pulley Set (4WD)
6	.078" x 5/16" spirol pin	A-6403	.078" x 5/16" Pins - Slipper Shaft (XX-4)
7	Slipper shaft	A-3221	Slipper Shaft Assembly with Hardware (XX-4)
8	5-40 x 5/8" set screw	A-3221	Slipper Shaft Assembly with Hardware (XX-4)
9	Allen wrenches	N/A	N/A
10	Front slipper back plate	A-3222	Slipper Back Plate - Front (XX-4)
11	Front slipper pad (yellow)	A-3123	Slipper Pad
12	Spur gear	A-3930	84-Tooth, 48-Pitch Spur Gear (XX-4)
13	Rear slipper pad (dark-colored)	A-3224	Slipper Pad Rear (XX-4)
14	29-tooth 2mm belt pulley	A-3210	Drive and Differential Pulley Set (4WD)
15	Rear slipper back plate	A-3223	Slipper Back Plate - Rear (XX-4)
16	Pulley flange	A-3210	Drive and Differential Pulley Set (4WD)
17	Slipper thrust washer	A-3125	1/4" x 9/16" Thrust Bearing Assembly
18	Slipper thrust bearing	A-3125	1/4" x 9/16" Thrust Bearing Assembly
19	Thrust bearing spacer	A-3217	Bearing Inserts and O-Rings (4WD)
20	3/16" x 3/8" bearing	A-6903	3/16" x 3/8" Bearings
21	Small plastic bearing washer	A-2127	'CR' Rear Hub Spacers .060"
22	1/8" Belleville washers	A-3242	Slipper Belleville Spring Washer Set (XX-4)
23	5-40 locknut	A-6302	5-40 Steel Locking Nuts
24	One-way/clicker pulley	A-3214	One-Way/Clicker, Spring, & Belt Roller Set (4WD)
25	One-way/clicker plate	A-3214	One-Way/Clicker, Spring, & Belt Roller Set (4WD)
26	One-way adjustment spring	A-3214	One-Way/Clicker, Spring, & Belt Roller Set (4WD)
27	Adjustment spring washer	A-3214	One-Way/Clicker, Spring, & Belt Roller Set (4WD)
28	4-40 mini locknut	A-6306	4-40 Aluminum Mini Nuts
29	Short 2mm drive belt	A-3206	Front/Side Drive Belt 196mm (4WD)
30	Chassis	A-4201	Main Chassis - Stiffezel (XX-4)
31	Belt roller	A-3214	One-Way/Clicker, Spring, & Belt Roller Set (4WD)
32	Belt roller shaft	A-3240	Belt Roller Shafts and Shims (4WD)
33	3/32" shim	A-3240	Belt Roller Shafts and Shims (4WD)
34	Right layshaft bearing insert	A-3217	Bearing Inserts and O-Rings (4WD)
35	Left layshaft bearing insert	A-3217	Bearing Inserts and O-Rings (4WD)
36	Rear drive belt	A-3201	Rear Drive Belt 366mm (XX-4)
37	Diff nut carrier	A-3078	Differential Screw, Hardware, and Seal
38	Diff tube	A-3072	Differential Tube
39	Steel outdrive/diff half	A-3073	Outdrive Cup
40	Diff grease (clear)	A-3065	Silicone Differential Compound
41	Diff drive ring	A-3070	Differential Drive Rings
42	5mm x 8mm bearing	A-6907	5mm x 8mm Bearings
43	Rear diff pulley	A-3210	Drive and Differential Pulley Set (4WD)
44	3/32" diff ball	A-6951	3/32" Carbide Balls
45	1/4" x 5/16" shim	A-6230	Shim Assortment - 3/32", 3/16", 1/4", 1/2"
46	Diff adjusting screw	A-3078	Differential Screw, Hardware, and Seal
47	Foam thrust bearing seal	A-3078	Differential Screw, Hardware, and Seal
48	3mm x 8mm raced thrust bearing washers	A-3071	Differential Thrust Bearing Assembly
49	White thrust bearing/assembly grease	A-3066	Teflon™ Assembly Grease
50	3mm x 8mm thrust bearing	A-3071	Differential Thrust Bearing Assembly
51	Rear bearing blocks	A-3217	Bearing Inserts and O-Rings (4WD)
52	1/2" x 3/4" bearing	A-6908	1/2" x 3/4" Bearings w/Teflon™ Seal
53	Main chassis cover	A-4208	Chassis Cover Set (XX-4)
54	Long threaded inserts	A-4224	Threaded Chassis Inserts - Short & Long (4WD)
55	4-40 x 3/8" cap-head screw	A-6206	4-40 x 3/8" Cap-Head Screws
56	4-40 x 1/2" cap-head screw	A-6204	4-40 x 1/2" Cap-Head Screws

# SPARE PARTS LIST

KEY #	KIT/PART DESCRIPTION	PART NO.	SPARE PARTS DESCRIPTION
57	4-40 x 5/8" cap-head screw	A-6221	4-40 x 5/8" Cap-Head Screws
58	4-40 x 3/4" cap-head screw	A-6211	4-40 x 3/4" Cap-Head Screws
59	Steering tunnel	A-4208	Chassis Cover Set (XX-4)
60	3/16" x 5/16" plastic steering bushing	A-1550	Steering Linkage/Bellcrank Set (4WD)
61	Steering idler arm	A-1550	Steering Linkage/Bellcrank Set (4WD)
62	3/16" ball stud	A-6001	Studded Balls w/Rod Ends 4-40 x 3/16"
63	Steering bellcrank	A-1550	Steering Linkage/Bellcrank Set (4WD)
64	Steering drag link	A-1550	Steering Linkage/Bellcrank Set (4WD)
65	Short threaded inserts	A-4224	Threaded Chassis Inserts - Short & Long (4WD)
66	Right plastic outdrive/diff half	A-3097	Molded Front Outdrive Set (Dogbone) (4WD)
67	Front diff pulley	A-3210	Drive and Differential Pulley Set (4WD)
68	Left plastic outdrive/diff half	A-3097	Molded Front Outdrive Set (Dogbone) (4WD)
69	Outdrive bearing O-ring	A-3218	O-rings for Outdrive Bearing (4WD)
70	Front belt cover	A-4208	Chassis Cover Set (XX-4)
71	1/4" x 3/8" plastic steering bushing	A-1550	Steering Linkage/Bellcrank Set (4WD)
72	Steering bellcrank arm	A-1550	Steering Linkage/Bellcrank Set (4WD)
73	4-40 x 1/4" button-head screw	A-6234	4-40 x 1/4" Button-Head Screws
74	XX-4 sticker sheet	A-8319	XX-4 Sticker Sheet
75	1/8" stainless washer	A-6350	Washer Assortment (Pivot Ball, #4, 1/8")
76	Front bulkhead	A-1201	Front Bulkhead (4WD)
77	Front suspension arm	A-1210	Front Suspension Arms (XX-4)
78	Inner front hinge pin	A-2007	Hinge Pin 1.42"
79	1/8" E-clip	A-6100	E-Clips 1/8"
80	5-40 x 1/8" set screw	A-6228	5-40 x 1/8" Hardened Set Screws
81	Front bumper	A-4217	Front and Rear Bumper Set (XX-4)
82	4-40 x 1/2" flat-head screw	A-6220	4-40 x 1/2" Flat-Head Screws
83	4-40 x 1/4" flat-head screw	A-6213	4-40 x 1/4" Flat-Head Screws
84	Front shock tower	A-1204	Front Shock Tower (XX-4)
85	4-40 x 7/8" cap-head screw	A-6216	4-40 x 7/8" Cap-Head Screws
86	Top shock mount bushing	A-5008	Upper Shock Mount Bushing
87	Left spindle	A-1216	Front Spindles and Carriers (4WD)
88	Right spindle	A-1216	Front Spindles and Carriers (4WD)
89	1/4" x 3/8" bearing	A-6913	1/4" x 3/8" Ball Bearing w/Teflon™ Seals
90	Front stub axle	A-1219	Front Stub Axle and Hardware (4WD)
91	Front universal yoke	A-3236	Front Drive Yokes and Screws (4WD)
92	2-56 x 1/4" cap-head screw	A-6232	2-56 x 1/4" Cap-Head Screws
93	Front universal pivot	A-1221	Front Universal Pivots (4WD)
94	Front dogbone	A-3230	Front Dogbone/Driveshaft (XX-4)
95	1/16" x 3/8" spirol pin	A-6402	1/16" x 3/8" Pins - Front U-Joint (4WD)
96	Team Losi assembly wrench	A-6030	Assembly Wrench (version 2)
97	Ball stud washer	A-6350	Washer Assortment (Ball Stud, #4, 1/8")
98	1/4" ball stud	A-6006	Studded Ball w/Ends 4-40 x 1/4"
99	Left spindle carrier	A-1216	Front Spindles and Carriers (4WD)
100	Right spindle carrier	A-1216	Front Spindles and Carriers (4WD)
101	Kingpin/hinge pin screw	A-6235	Kingpin/Hinge Pin Screws (4WD)
102	Plastic rod end	A-6005	H.D. 30° Plastic Rod Ends
103	1-5/8" turnbuckle	A-6035	Adjustable Threaded L/R Rod Set w/ends 1.625"
104	Foam thing	A-6003	Foam Things (Linkage Ring)
105	Left rear suspension pivot	A-2210	Rear Pivot Blocks and Anti-Squat Shims
106	Left rear suspension arm (marked 'R')	A-2131	'CR' Rear Suspension Arms
107	Inner rear hinge pin	A-2161	Inner Rear Hinge Pins
108	Right rear suspension pivot	A-2210	Rear Pivot Blocks and Anti-Squat Shims
109	Right rear suspension arm (marked 'L')	A-2131	'CR' Rear Suspension Arms
110	Rear shock tower	A-2204	Rear Shock Tower (XX-4)
111	Wing mount	A-4222	Wing Mount Set (XX-4)
112	Wing mount washer	A-4222	Wing Mount Set (XX-4)

# SPARE PARTS LIST

KEY #	KIT/PART DESCRIPTION	PART NO.	SPARE PARTS DESCRIPTION
113	Body clip	A-8200	Body Clips
114	4-40 x 5/8" flat-head screw	A-6233	4-40 x 5/8" Flat-Head Screws
115	Rear bumper	A-4217	Front and Rear Bumper Set (XX-4)
116	4-40 x 3/8" flat-head screw	A-6210	4-40 x 3/8" Flat-Head Screws
117	Rear dogbone	A-3081	Buggy Dogbone/Drive Shaft w/Yoke
118	Rear universal yoke	A-3083	Yoke and Screw for Dogbone/Drive Shaft
119	Rear universal pivot	A-3014	Universal Pivots
120	Rear axle	A-3015	Rear Axle, Spacer, and Pin
121	3/32" x 1/2" spirol pin	A-6400	3/32" Pins for U-Joint
122	Left rear hub	A-2125	Rear Hub Set
123	Rear axle spacer	A-3016	Rear Axle Spacers
124	1/16" x 7/16" spirol pin	A-6401	1/16" Pins for Wheels and Gear
125	Right rear hub	A-2125	Rear Hub Set
126	Rear hub spacer	A-2216	Rear Hub Spacers .050" (4WD)
127	Outer rear hinge pin	A-2164	Outer Rear Hinge Pins
128	1-3/8" turnbuckle	A-6034	Adjustable Threaded L/R Rod Set w/Ends 1.375"
129	Shock O-ring	A-5015	Double O-ring Shock Cartridge
130	Shock cartridge body	A-5015	Double O-ring Shock Cartridge
131	Shock cartridge spacer	A-5015	Double O-ring Shock Cartridge
132	Shock cartridge cap	A-5015	Double O-ring Shock Cartridge
133	Shock fluid	A-5224	SILATECH Competition Shock Fluid 350/30wt
134	Front shock shaft	A-5004	Shock Shaft .6"
135	Rear shock shaft	A-5022	Shock Shaft 1.2"
136	Shock end	A-5023	Spring Clamps and Cups
137	1/4" swivel ball	A-2006	Swivel Suspension Balls .250"
138	Shock spacer	A-5015	Double O-ring Shock Cartridge
139	Black, #57 shock piston	A-5045	Teflon™ Shock Pistons #57 (Black)
140	Red, #56 shock piston	A-5046	Teflon™ Shock Pistons #56 (Red)
141	Short, front shock body	A-5029	.6" Shock Body Hard Anodized
142	Long, rear shock body	A-5031	1.2" Shock Body Hard Anodized
143	Bottom shock spring cup	A-5023	Spring Clamps and Cups
144	Front shock spring	A-5132	2" Spring 3.5 Rate (Green)
145	Rear shock spring	A-5150	2.5" Spring 2.3 Rate (Pink)
146	Shock spring collar	A-5023	Spring Clamps and Cups
147	4-40 locknut	A-6305	4-40 Locking Nuts - Low Profile
148	Front tire	A-7281S	4WD Front IFMAR PIN (Silver) w/Foam Liners
149	Rear tire	A-7367S	2.2" Rear IFMAR PIN (Silver) w/Foam Liners
150	Front wheel	A-7045	XX-4 Front 5-Spoke Wheels (Yellow)
151	Rear wheel	A-7141	5-Spoke Rear Wheel (Yellow)
152	Front foam tire liners	A-7299	Buggy Front CLOUDS Foam Liners
153	Rear foam tire liners	A-7399	Buggy Rear CLOUDS Foam Liners
154	10-32 locknut	A-6303	10-32 Nylon Locking Nuts (4ea. Nylon & Steel)
155	Motor mount	A-3219	Motor Mount and Screws (4WD)
156	3mm x 8mm motor screw	A-6201	3mm x 8mm Cap-Head Screws w/Washers (Motor)
157	Motor mount clamp	A-4215	Motor Mount Clamp (4WD)
158	4-40 x 1/8" button-head screw	A-6212	4-40 x 1/8" Button-Head Screws
159	Round, one-way/clicker adjustment plug	A-3244	Access Plugs (4WD)
160	Rectangular, gear mesh access plug	A-3244	Access Plugs (4WD)
161	Steering servo mount	A-1550	Steering Linkage/Bellcrank Set (4WD)
162	#4 washer	A-6350	Washer Assortment (Ball Stud, #4, 1/8")
163	4-40 x 3/8" button-head screw	A-6229	4-40 x 3/8" Button-Head Screws
164	Servo arm	A-1550	Steering Linkage/Bellcrank Set (4WD)
165	Steering rod	A-6042	Steering Rod and Ball Cups - 3.25" (4WD)
166	Battery strap/body mount post	A-4220	Battery Post/Hold-Down Straps (4WD)
167	Foam battery pad	A-4226	Foam Battery Pads (4WD)
168	Battery hold-down strap	A-4220	Battery Post/Hold-Down Straps (4WD)

# SPARE PARTS LIST

KEY #	KIT/PART DESCRIPTION	PART NO.	SPARE PARTS DESCRIPTION
169	Thick two-sided tape	A-4004	Servo Tape
170	Antenna tube	A-4002	Antenna Kit
171	Antenna cap	A-4003	Antenna Caps
172	Body	A-8044	XX-4 Body w/Window masks
173	Wing	A-8108	XX-4 Maxi-Wing
174	Window mask	A-8044	XX-4 Body w/Window masks
175	One-way/clicker pulley flange	A-3214	One-Way/Clicker, Spring, & Belt Roller Set (4WD)
176	Thin two-sided tape	A-4004	Servo Tape
177	Rear Hinge Pine Brace	A-2209	Rear Hinge Pin Support Bracket (4WD)

## GLOSSARY of R/C TERMS

<b>Ackerman</b>	The degree of difference in the steering angle between the inside and outside wheel when the car is turning.
<b>Anti-squat</b>	The angle, from horizontal, of the inner rear hinge pin in relationship to the chassis. Anti-squat helps to keep the rear suspension from squatting under acceleration.
<b>C.G. (center of gravity)</b>	The point on the chassis at which the car balances with all components installed.
<b>Camber</b>	The angle, from vertical, of the wheels. Negative camber is when the top of the tire is closer to the center of the car than the bottom of the tire. Negative camber is commonly used to add stability in bumps. Positive camber is when the bottom of the tire is closer to the center of the car than the top of the tire. Positive camber is <u>not</u> commonly used.
<b>Camber link</b>	The rod assembly used to connect the rear hub to the rear bulkhead and the front spindle carrier to the front shock tower.
<b>Caster</b>	The angle, from vertical, of the king pin in relationship to the ground.
<b>Glitch</b>	The most dreaded term ever to be heard around radio controlled vehicles. This is a term used to describe when the car does something different than what you tell it to do because of radio interference. This can happen for several reasons. The most common are: 1) someone turning on a radio that is on a frequency too close to your own, and 2) Electric components may be touching the chassis without insulation.
<b>Kick-up</b>	The angle of the entire front suspension, from horizontal, in relationship to the rest of the chassis.
<b>Oversteer</b>	A situation in which the front tires have more traction than the rear tires. This causes the rear tires to lose traction in corners.
<b>Ride height</b>	The point at which the car naturally rides.
<b>Tie rod</b>	The rod assembly used to connect the steering bellcrank and the steering idler arm to the spindle arms.
<b>Toe-in</b>	The front edge of both tires are closer together than the rear edge of both tires.
<b>Toe-out</b>	The front edge of both tires are farther apart than the rear edge of both tires.
<b>Understeer</b>	A situation in which the rear tires have more traction than the front tires. This causes the car to have inadequate steering.

