

Schumacher

COUGAR



INSTRUCTION MANUAL

- * FULLY DETAILED CONSTRUCTION DIAGRAMS
- * TRACK SETTINGS AND RACE TUNING TIPS

DESIGNED AND MANUFACTURED BY:

 **Schumacher**

Hanson Business Park, 71-73 Tenter Road,
Moulton Park, Northampton. NN3 1AX,
England

THE COUGAR SHARPENS ITS CLAWS

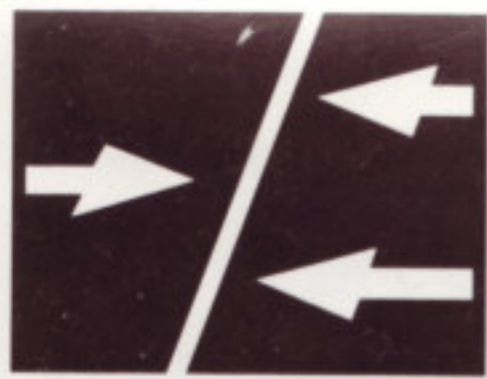

Schumacher

1/10 SCALE ELECTRIC R/C HIGH PERFORMANCE MODELS

911 turbo SE

Stunning 2WD rear motor racer.
Fully independent suspension, tough alloy chassis, realistic road tread tyres, fantastic speed and incredibly tough. Racing in the street, or over dirt or just burning rubber. DO IT WITH STYLE.

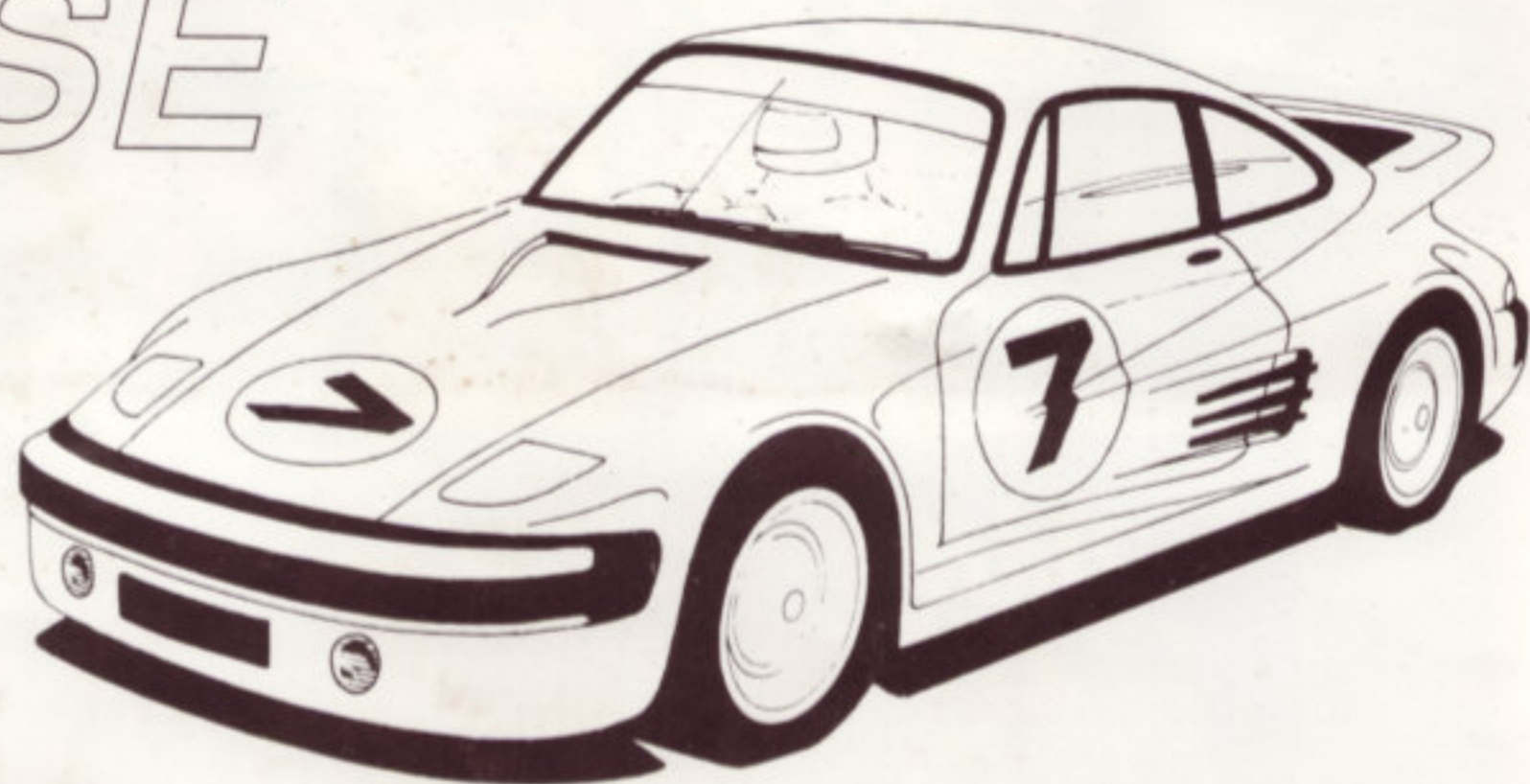

PRO-CAT

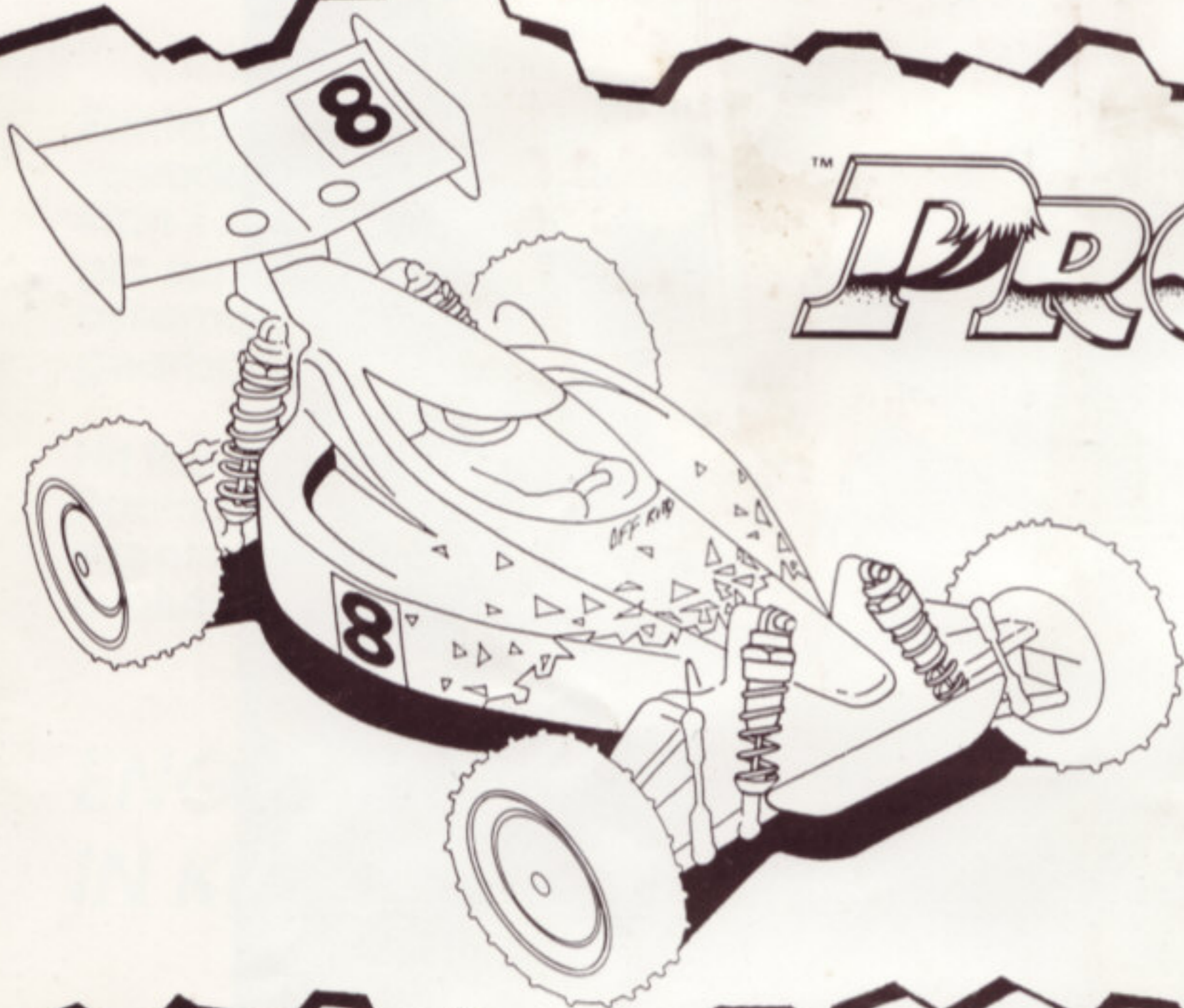

The PROCAT is fully specified for competition use and is race proven with many Championship victories. The sophisticated design features fully ballraced four wheel drive, two ball differentials, one way drive shafts, kevlar drive belts and precision machined alloy shock absorbers.

SHOTGUN

2WD RACING TRUCK

Simple rugged lightweight design with High Torque kevlar drive belt giving experts and beginners alike superb handling and performance straight out of the box.

Earth grabbing tyres and massive ground clearance mean this truck will tear up any terrain. BLAST AWAY THE OPPOSITION!

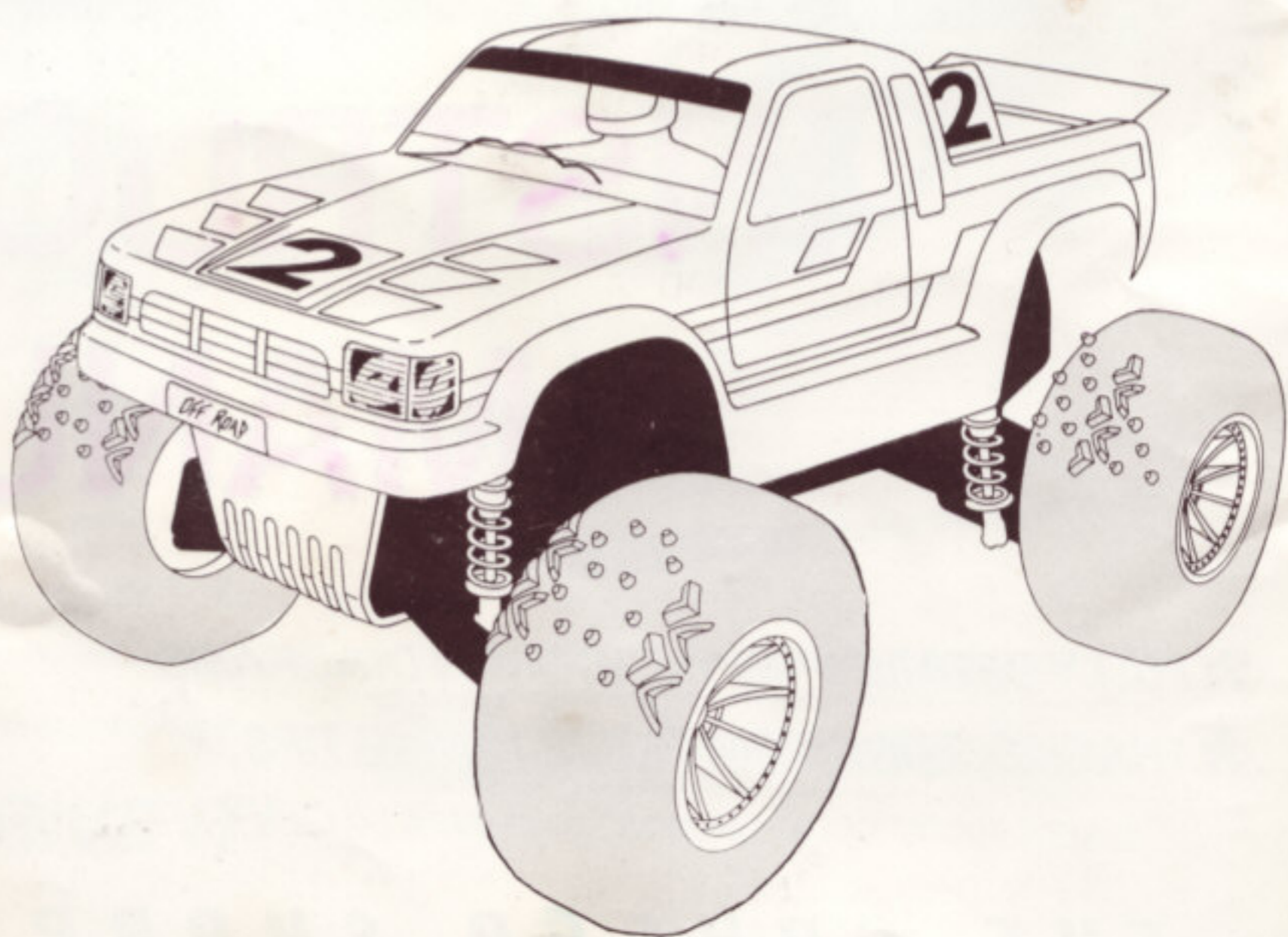



Schumacher

COUGAR 2

Congratulations on choosing a COUGAR 2.
The COUGAR 2 is a true competition bred off road racer designed so that adjustments can be made to suit different track conditions and driving styles. Extensive development of new materials and the complete re-design of many new parts, together with straight forward modular construction and clear concise instructions will give experts and beginners alike superb reliability and performance.

Have fun, enjoy your racing.

Cecil Schumacher

CONTENTS

	PAGE
TRANSMISSION ASSEMBLY	2-5
ROLLER DRIVE SHAFTS	3
BELT TENSION ADJUSTMENT	5
SLIPPER CLUTCH	6
REAR SUSPENSION	7-8
FRONT SUSPENSION	9-12
BALL-RACED STEERING LEVERS	11
SHOCK ABSORBERS	13-15
FITTING ELECTRICS	16-17
WHEELS & TYRES	18
BODYSHELL & WING MOUNT	19-20
TRACK SETTINGS	21-23

In line with our policy of continuous development the exact specification of the kit may vary.

MISSING OR DEFECTIVE PARTS

In the unlikely event of problems with your new kit you should contact the model shop where purchased, quoting part number, bag number and batch number for both the bag and the kit.

SCHUMACHER RACING PRODUCTS

HANSON BUSINESS PARK · 71-73 TENTER ROAD · MOULTON PARK · NORTHAMPTON · NN3 1AX

ISSUE 3

IMPORTANT SAFETY NOTES

1. Select an area for assembly that is away from reach of small children. The parts are small and can be swallowed by children causing choking and possible internal injuries.
2. Shock fluids, grease and adhesives should be kept out of childrens reach. They are not toxic, but were not intended for human consumption.
3. Exercise care when using any hand tools, sharp instruments and power tools during construction.
4. Carefully read all manufacturers warnings and cautions for any glues or paints that may be used for assembly purposes.

THREAD LOCK

Places to put threadlock. (It will prevent the screws and nuts vibrating loose.)

GREASE

Points where silicone grease (MS 1 or equivalent) should be applied. (It will reduce friction and assure smooth movement.)

OIL

Points where oil should be applied (Light machine oil, 3 in 1 or similar.)

Do not use excessive force when tightening the self-tapping screws, or you may strip the thread in the plastic. It is recommended to stop tightening it when the threaded part on the screw goes into the plastic part and you feel some resistance from the tightening.

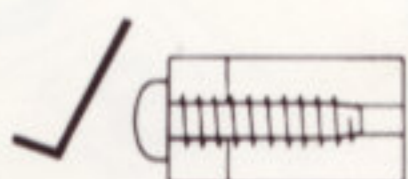

Good

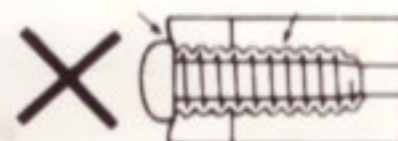

Over tighten and may strip the thread in the plastic

ADDITIONAL ITEMS REQUIRED

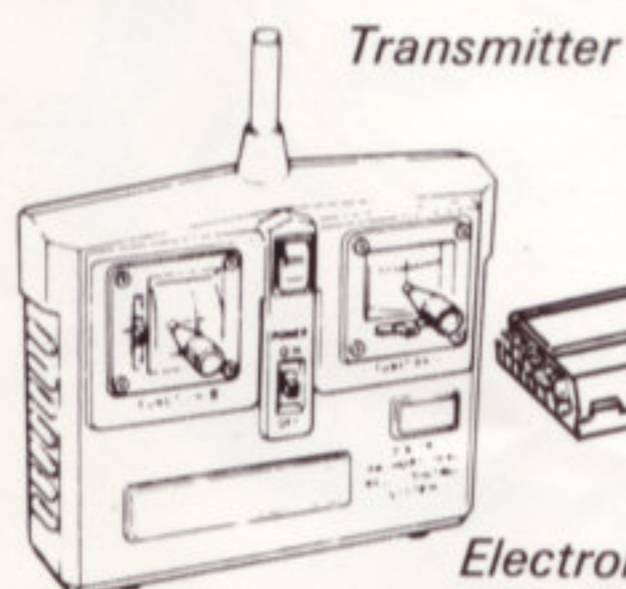

Servo



Receiver



(Battery for Radio system)

AA Size Battery
(For Transmitter
.... 8 pcs.)



Electronic speed controller

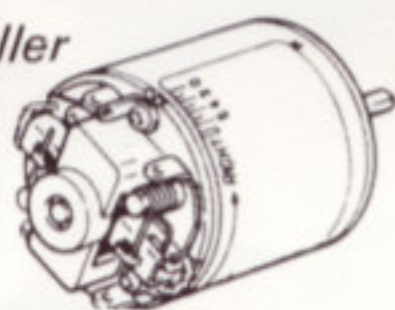

540
Type
Motor



7.2V
racing battery

FOR BEST PERFORMANCE, IT IS VERY IMPORTANT THAT GREAT CARE IS TAKEN TO ENSURE THE FREE MOVEMENT OF ALL PARTS. REMOVE ANY EXCESS FLASH FROM MOULDED PARTS.

TOOLS REQUIRED FOR ASSEMBLY

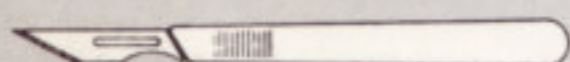
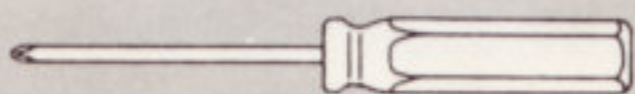
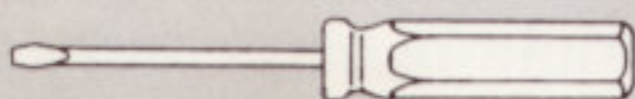
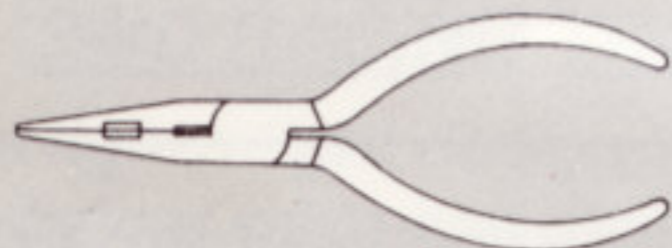
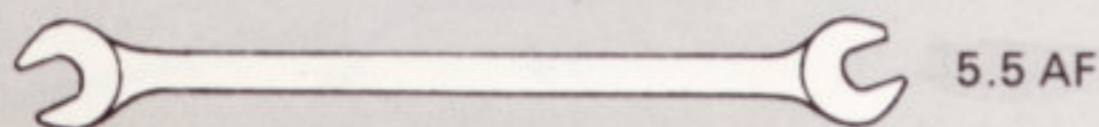

MATERIALS REQUIRED

Threadlock
Light oil for shock absorbers
Polycarbonate paint for bodyshell
Grease



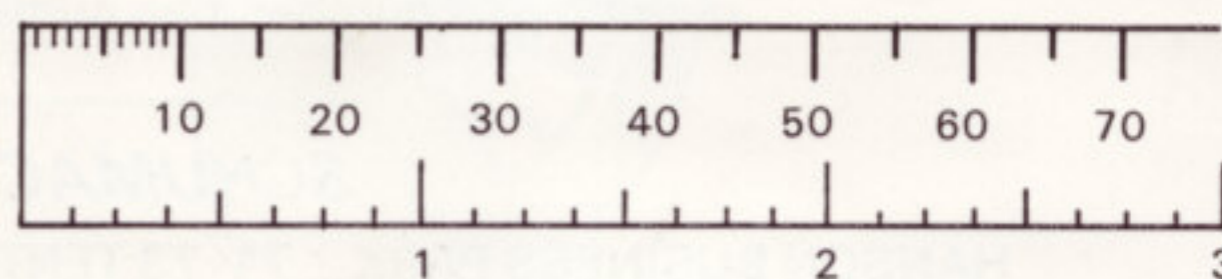

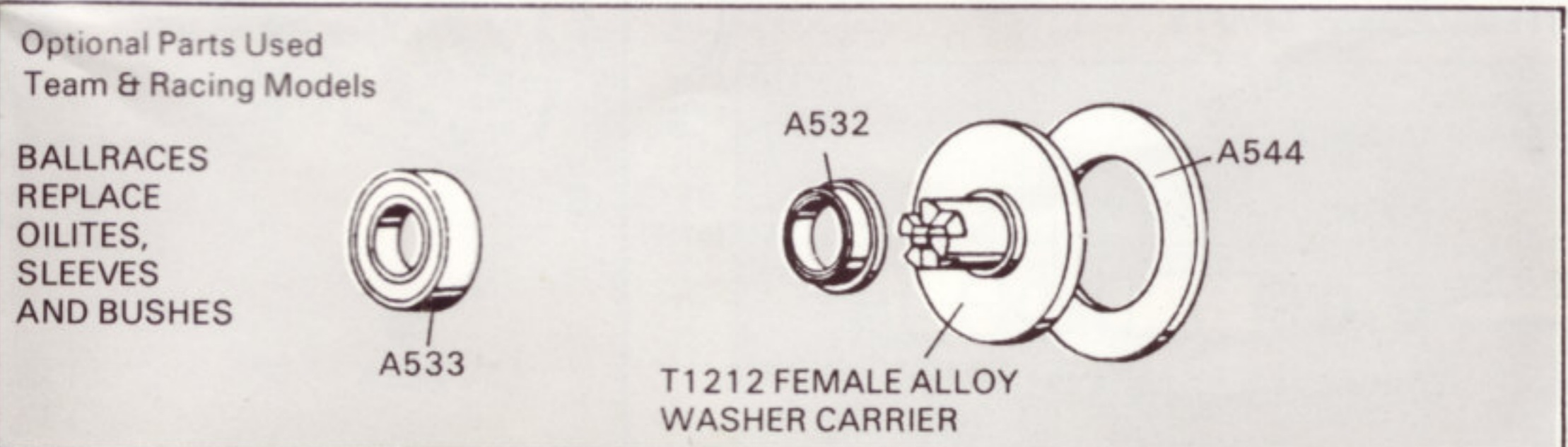
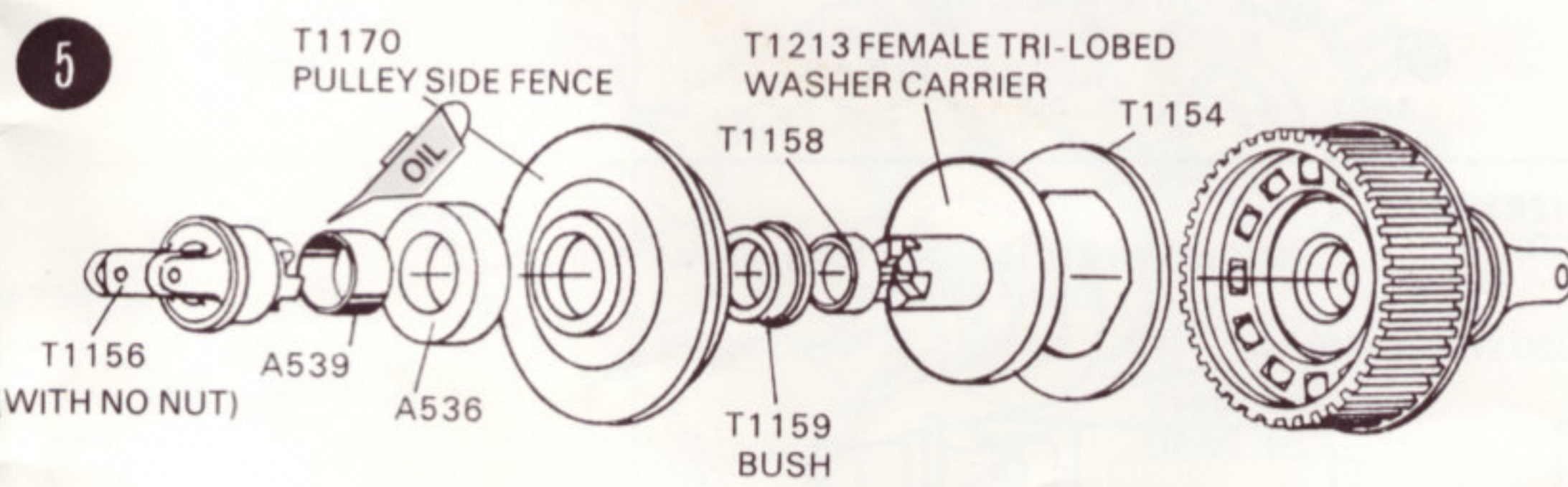
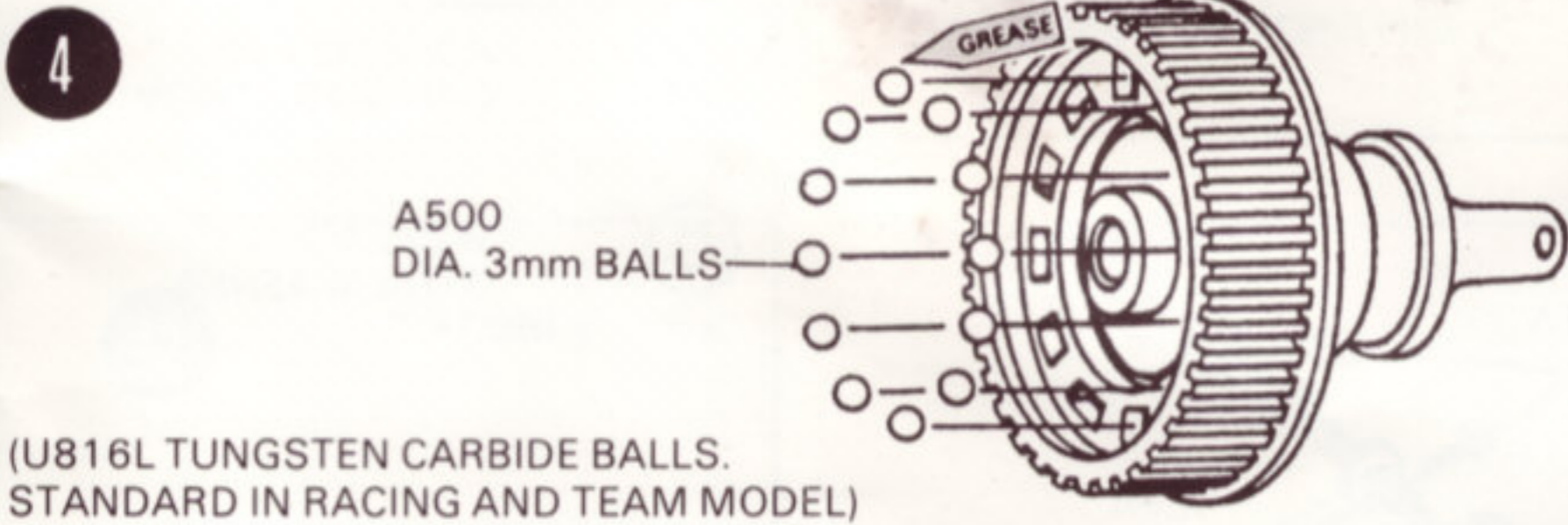
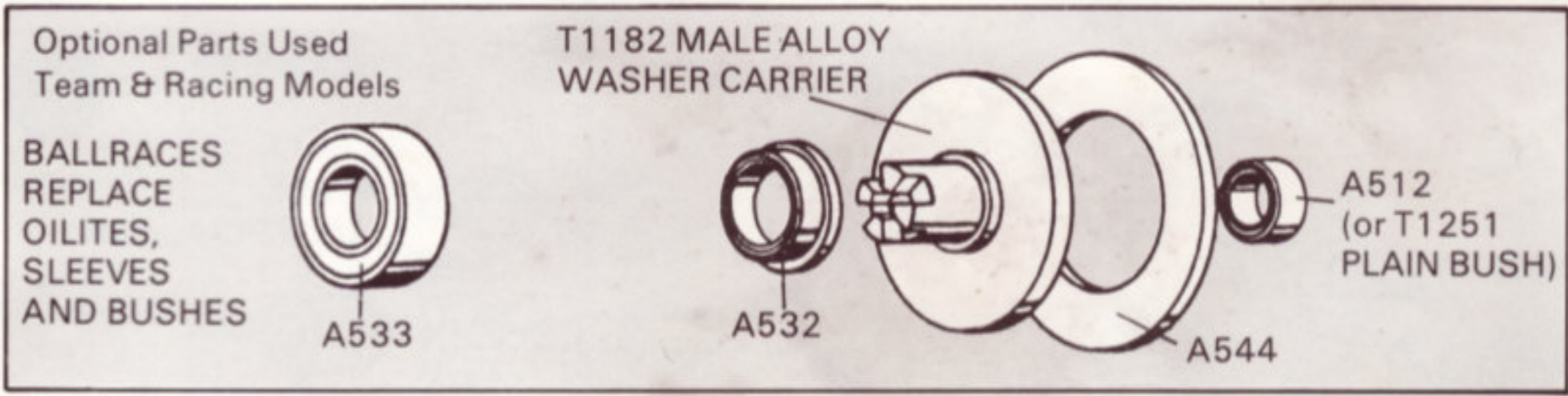
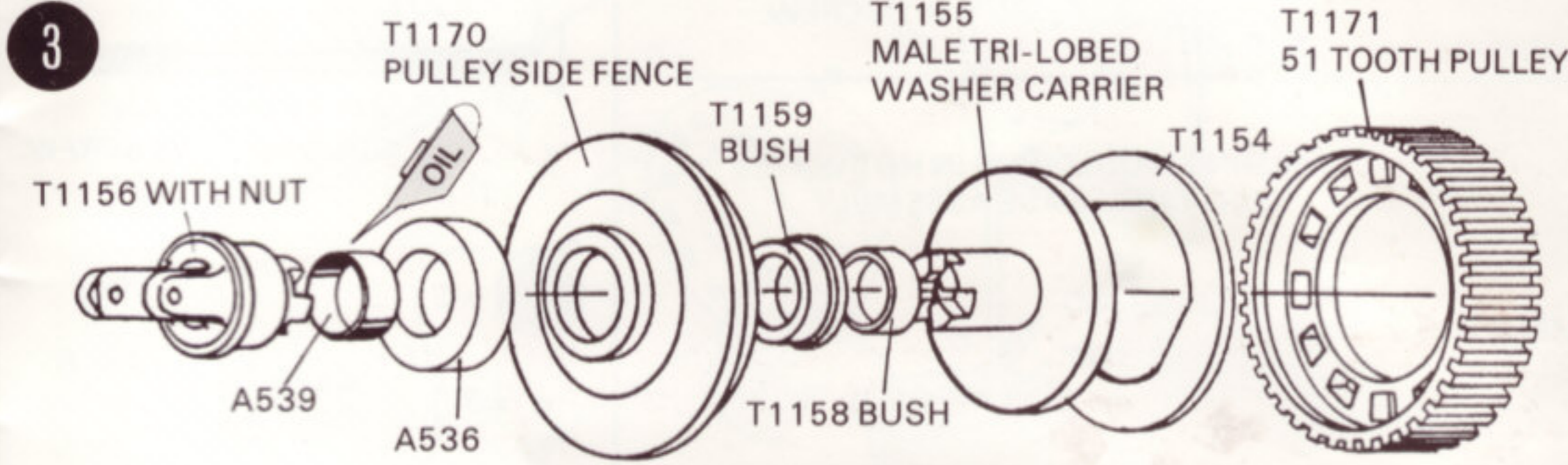
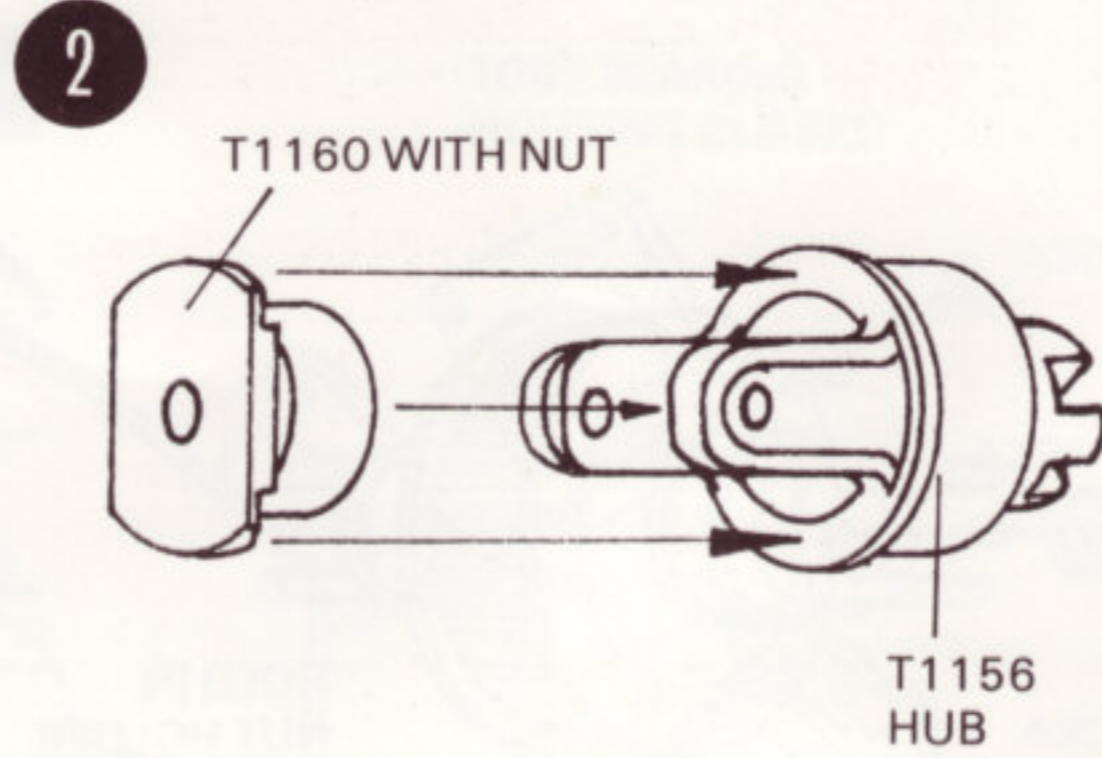
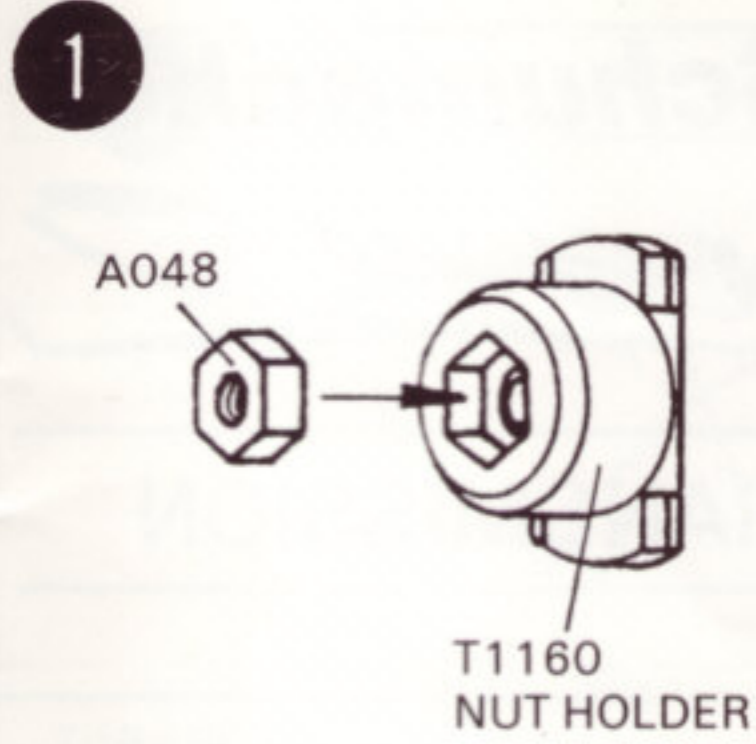

Ruler INCHES & MILLIMETRES



TRANSMISSION

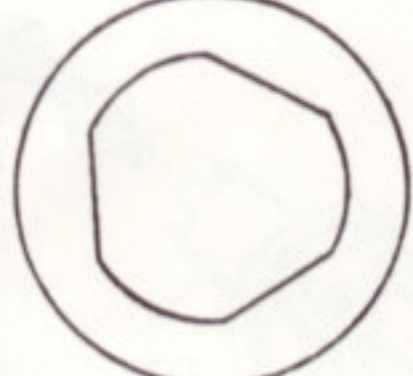

HARDWARE

-  A048 M3 NUT
x 1
-  A539 BEARING SLEEVE
x 2
-  A536 OILITE BEARING
x 2
-  T1158 BUSH
x 2
-  T1159 BUSH
x 2
-  A500 3mm DIA. BALL
x 12
-  T1154 TRI-LOBED WASHER
x 2

PART No.	SPARES No.
A533	U724X
A532	U762J
A512	U1028I
T1182/1212	U1245S
A544	U1243Q

6

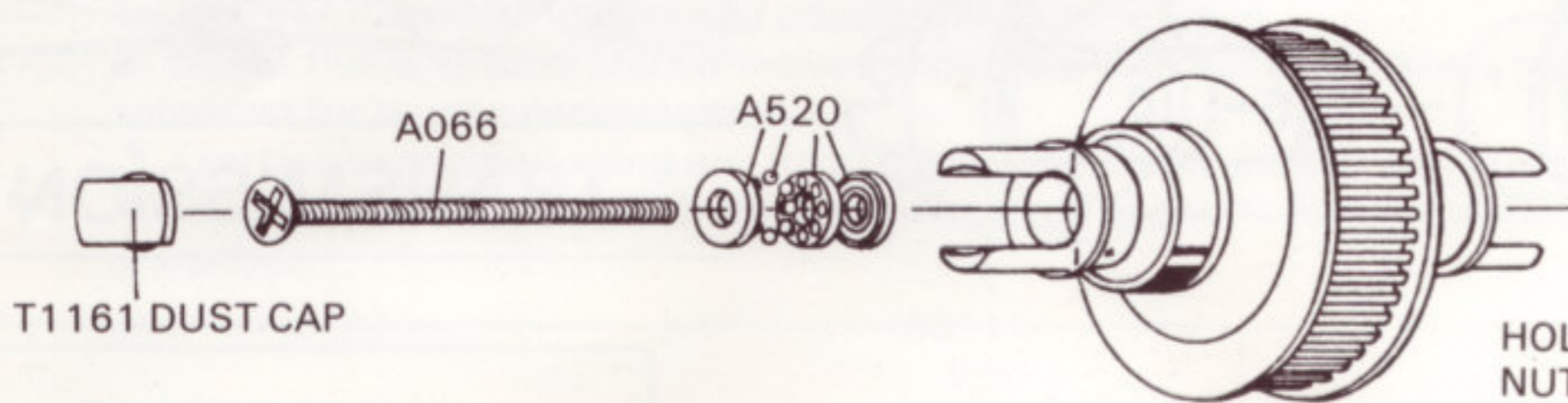

T1161 DUST CAP

HOLD IN
NUT HOLDER
WHILE
TIGHTENING
SCREW.

Schumacher

COUGAR 2

TRANSMISSION

7

UNIVERSAL JOINTS

WARMING MOULDINGS IN HOT WATER
FIRST WILL EASE ASSEMBLYFULLY LOCATE
LOWER PIN

ASSEMBLY TOOL

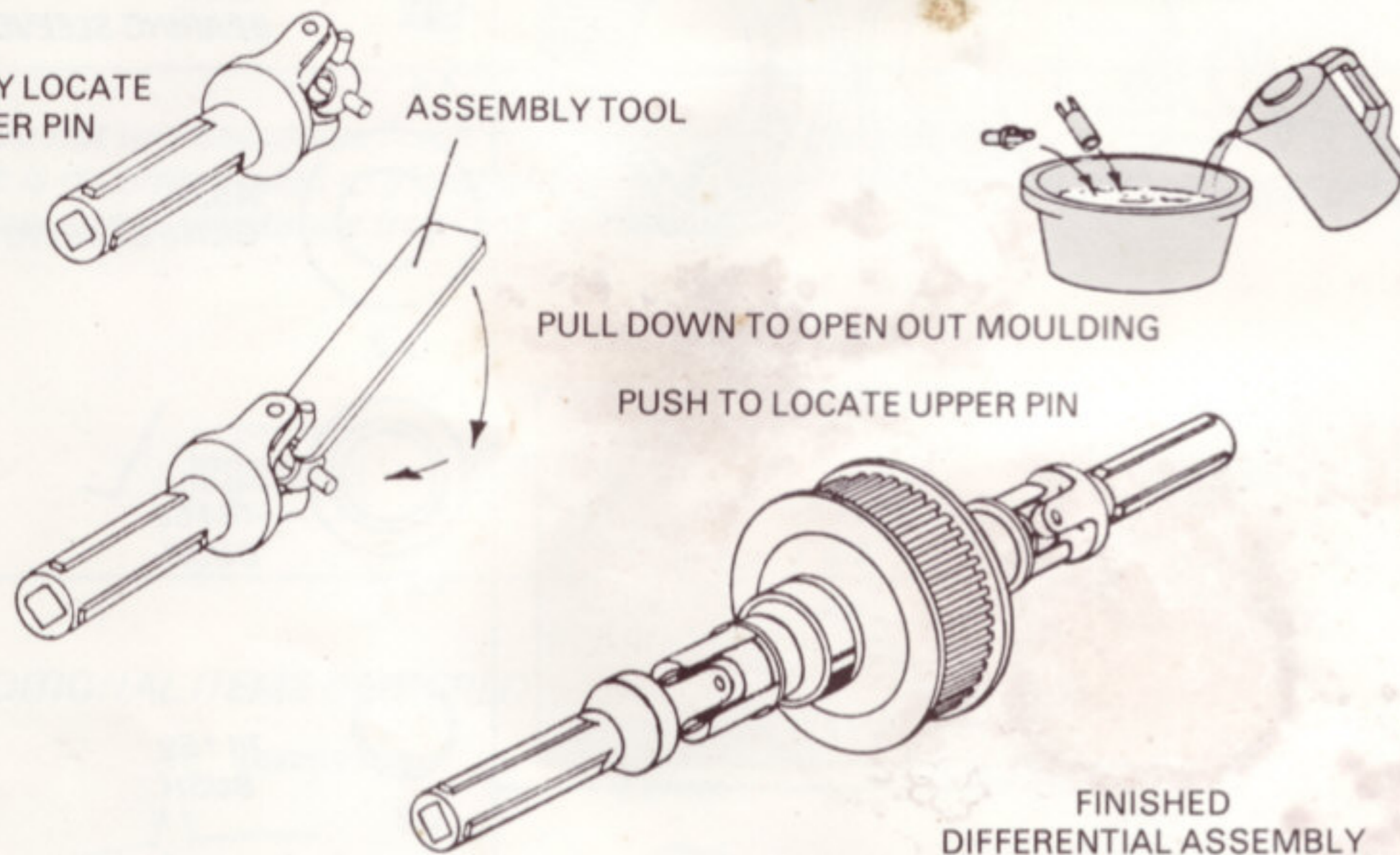

PULL DOWN TO OPEN OUT MOULDING

PUSH TO LOCATE UPPER PIN

FINISHED
DIFFERENTIAL ASSEMBLY

HARDWARE



x 1

A066 M3 x 45mm
COUNTERSUNK SCREW

x 2

x 8

A520 THRUST
RACE ASSEMBLY

x 1

T108
UNIVERSAL JOINT

x 4



x 1

A040 M3 x 20
CAPHEAD SCREW

x 1

A225 M3
STEEL WASHER

x 1

A048
M3 NUT

8

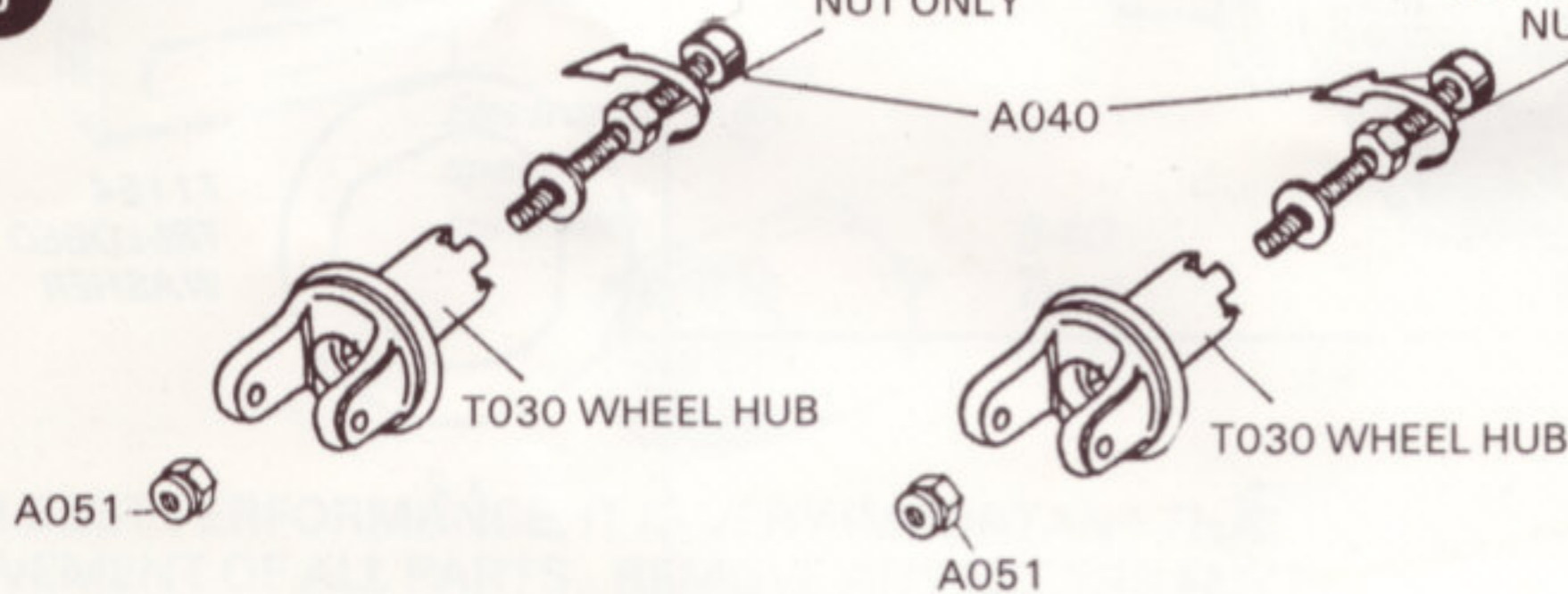
USE TO FIT NYLOC
NUT ONLYUSE TO FIT NYLOC
NUT ONLY

A040

T030 WHEEL HUB

T030 WHEEL HUB

A051

A051

9

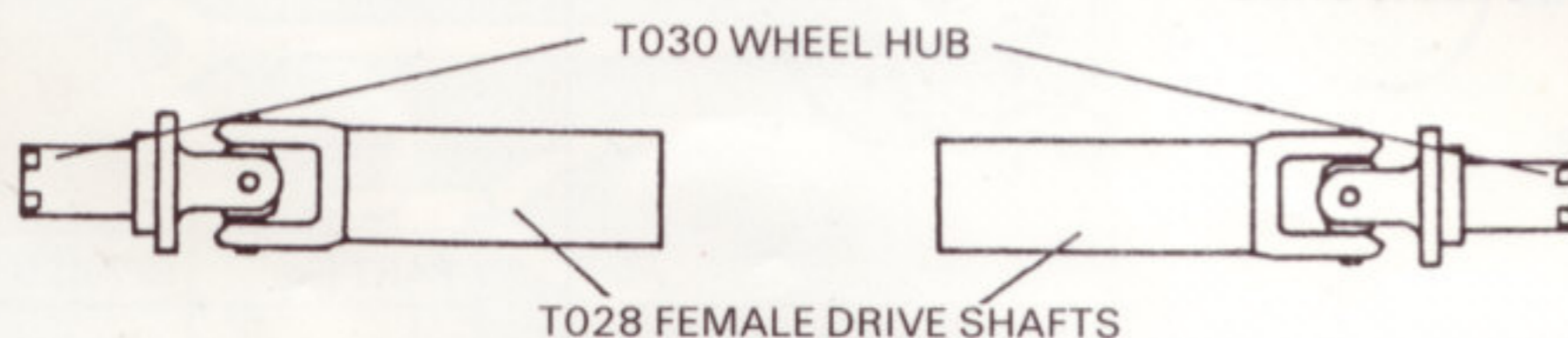
FIT UNIVERSAL JOINTS AS IN STEP 7 TO
T028 FEMALE DRIVE SHAFTSFIT T030 WHEEL HUBS TO T028 FEMALE
DRIVE SHAFTS

T030 WHEEL HUB

T028 FEMALE DRIVE SHAFTS

Optional Parts Used (Team Model)

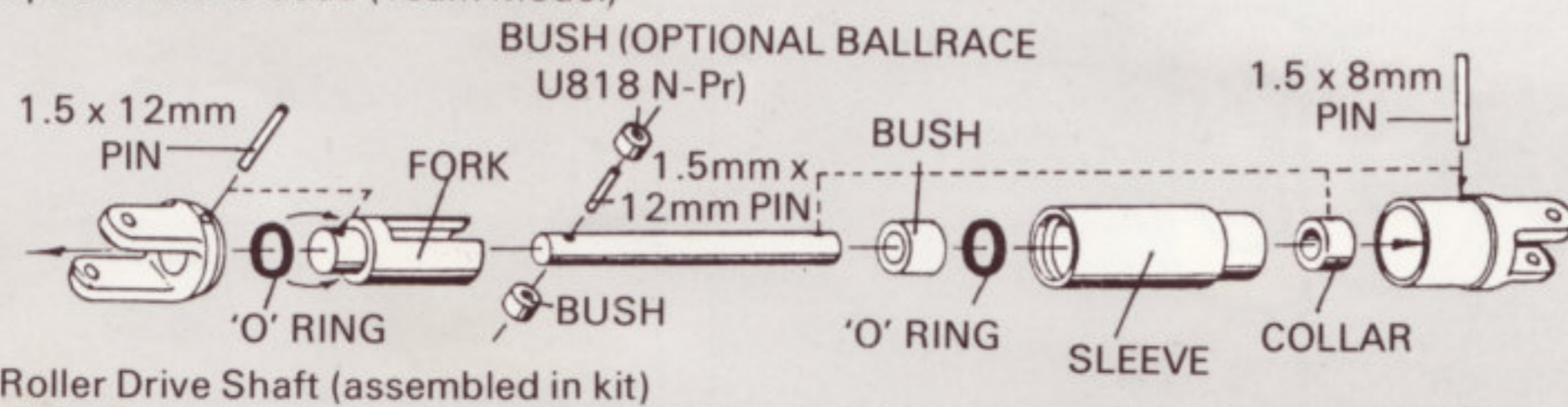

Roller Drive Shaft (assembled in kit)

10

T083 BEARING HOUSING CLOSED

Schumacher

COVER 2

TRANSMISSION

T180 MOTOR PLATE

T082 BEARING HOUSING OPEN

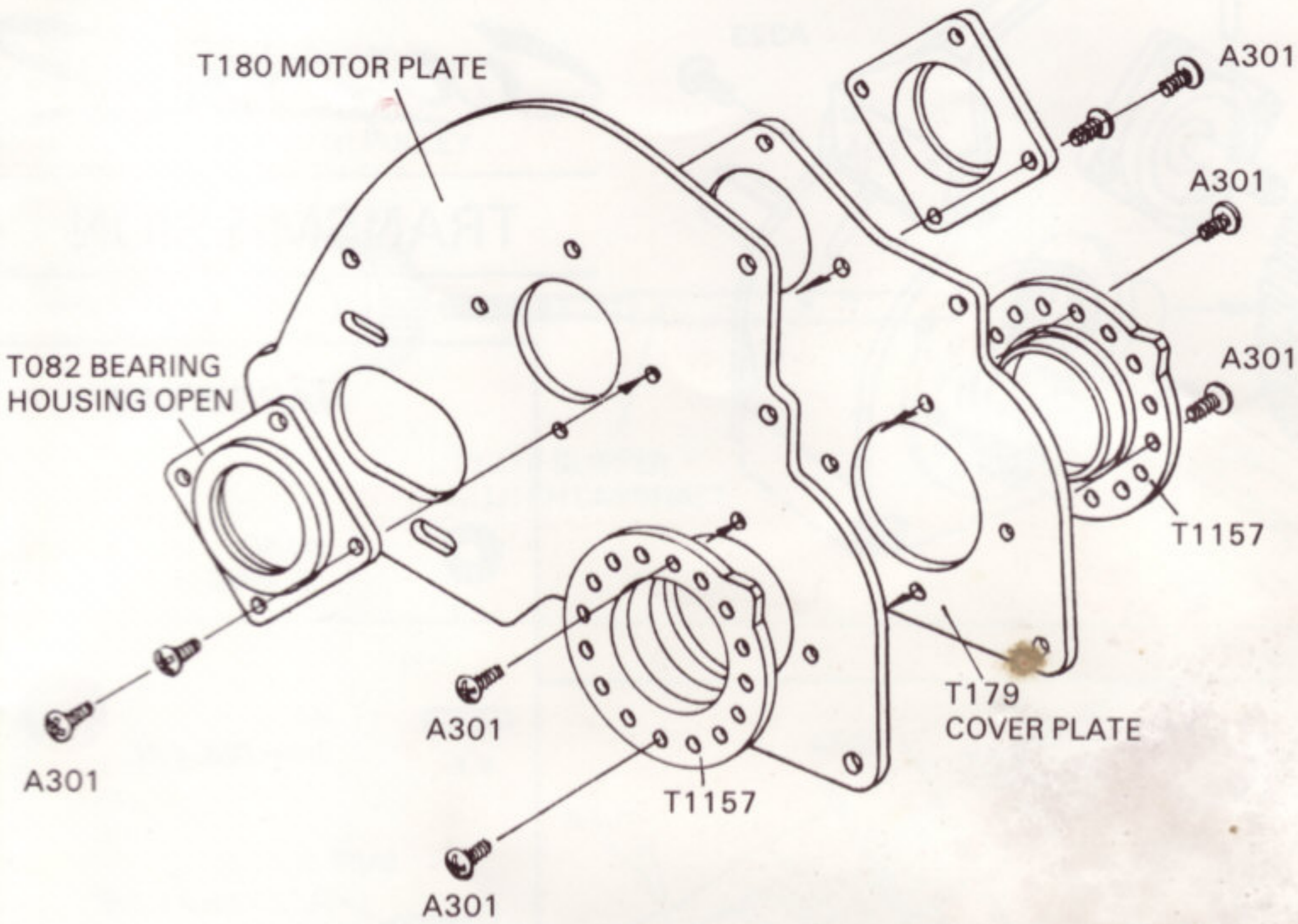

HARDWARE

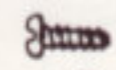
 **A301 No.2 x 3/16" PANHEAD SCREW**
x 8

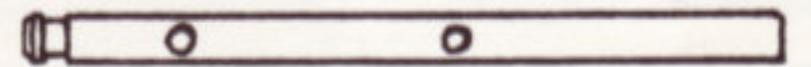

x 1 **T227 2WD LAYSHAFT**



x 1 **A401 1.5mm DIA. PIN**



A537 OILITE BEARING

x 2

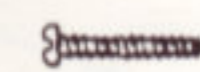

A304 No.2 x 3/8" SELFTAP PANHEAD SCREW

x 4

11

SPORT ONLY

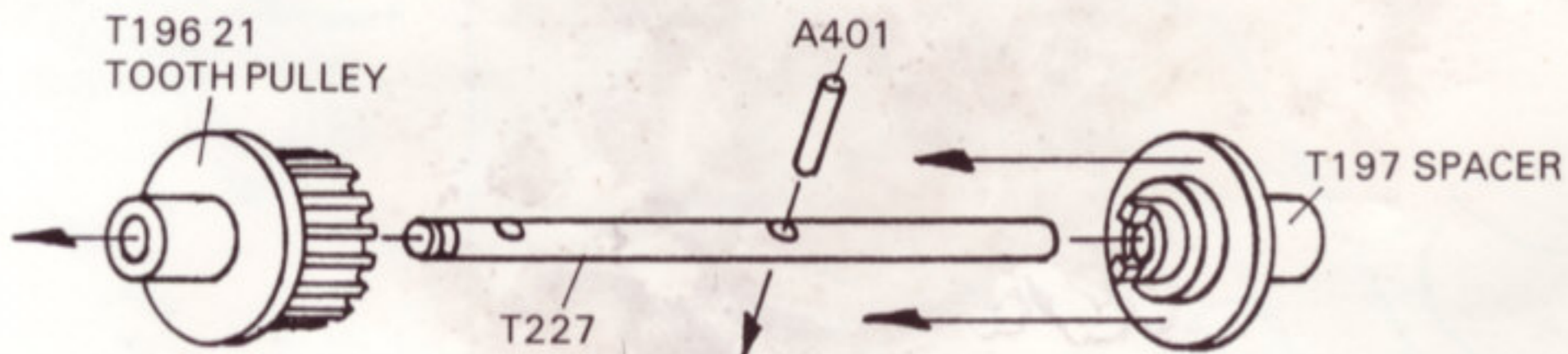

12

SPORT ONLY

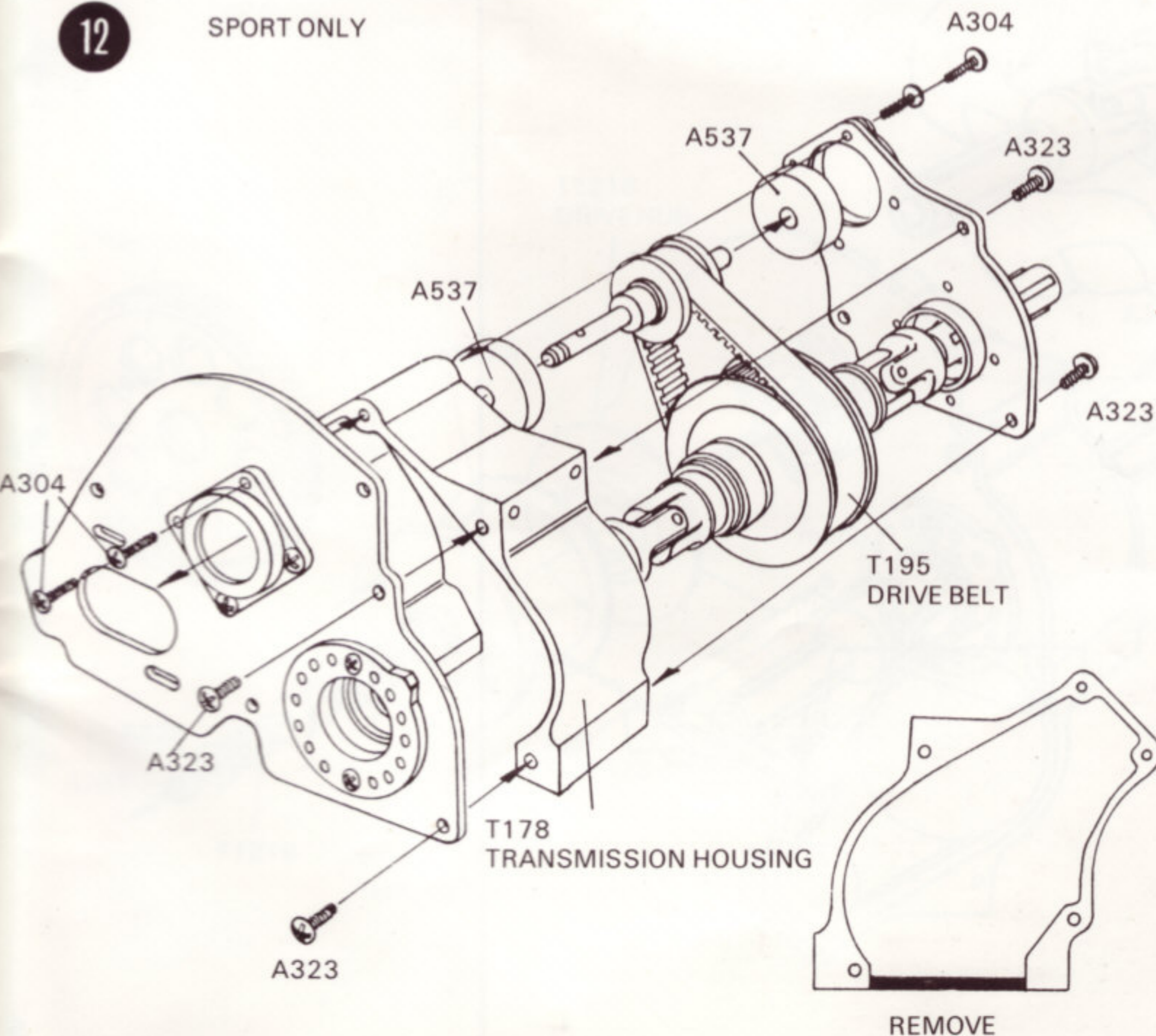

REMOVE

13

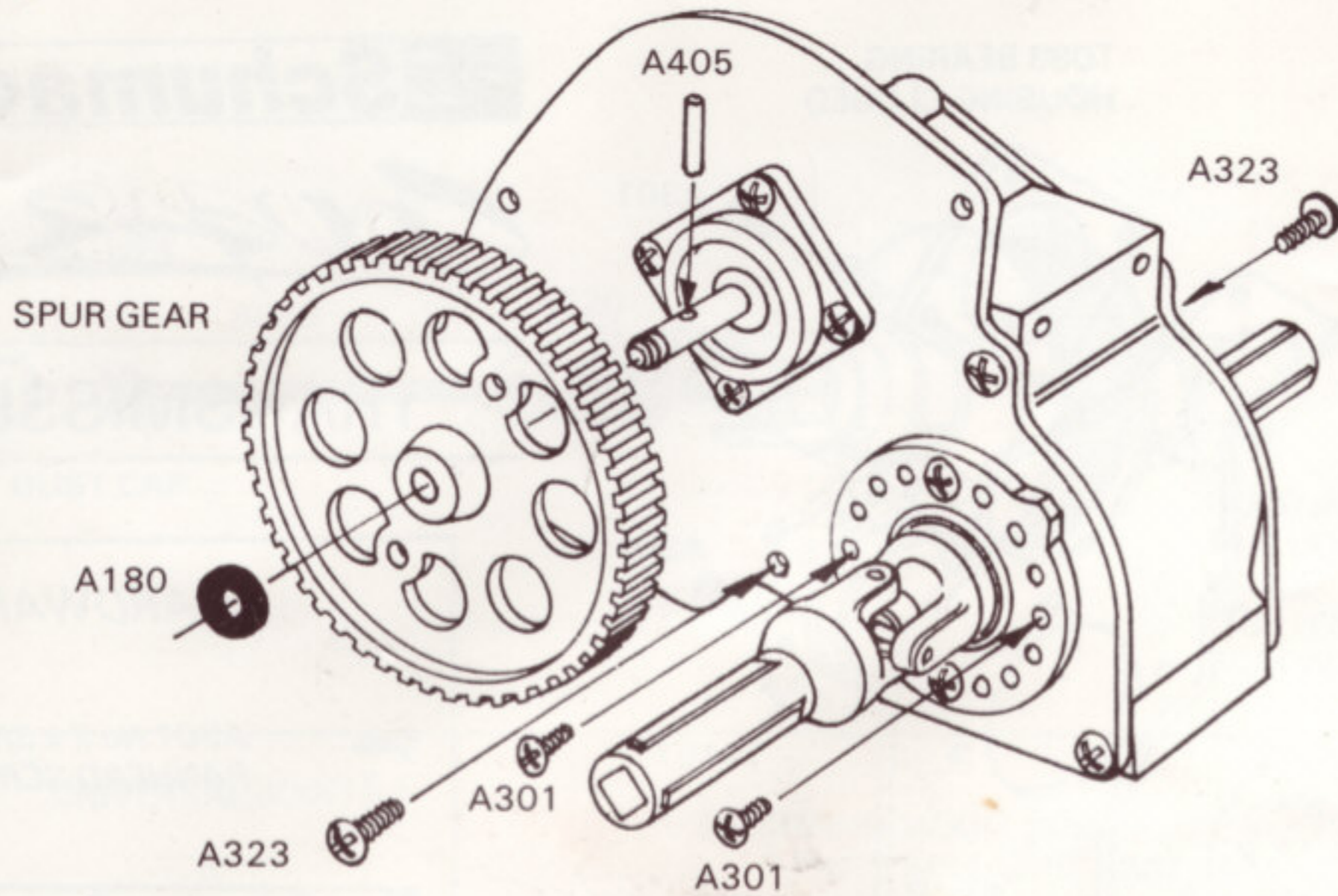

TRANSMISSION

HARDWARE



A180
'O' RING

x 1



A405
2mm DIA. PIN

x 1

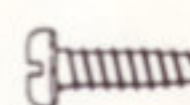

A323 No.4 x 3/8"
SELFTAP
PANHEAD SCREW

x 2

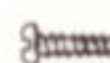

A301 No.2 x 3/16"
SELFTAP
PANHEAD SCREW

x 4

14

BELT TENSION ADJUSTMENT

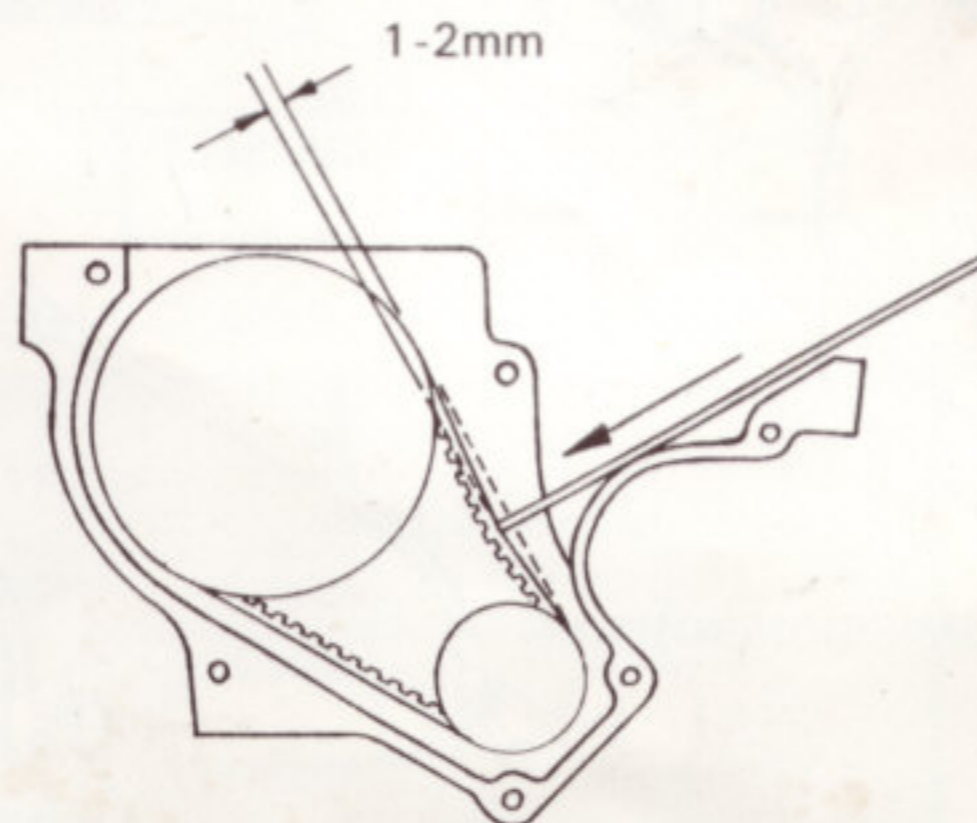
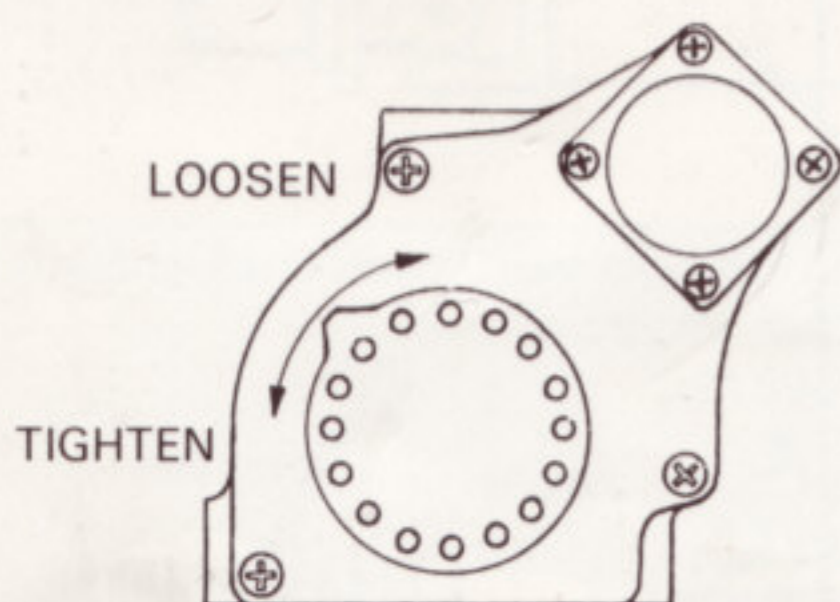
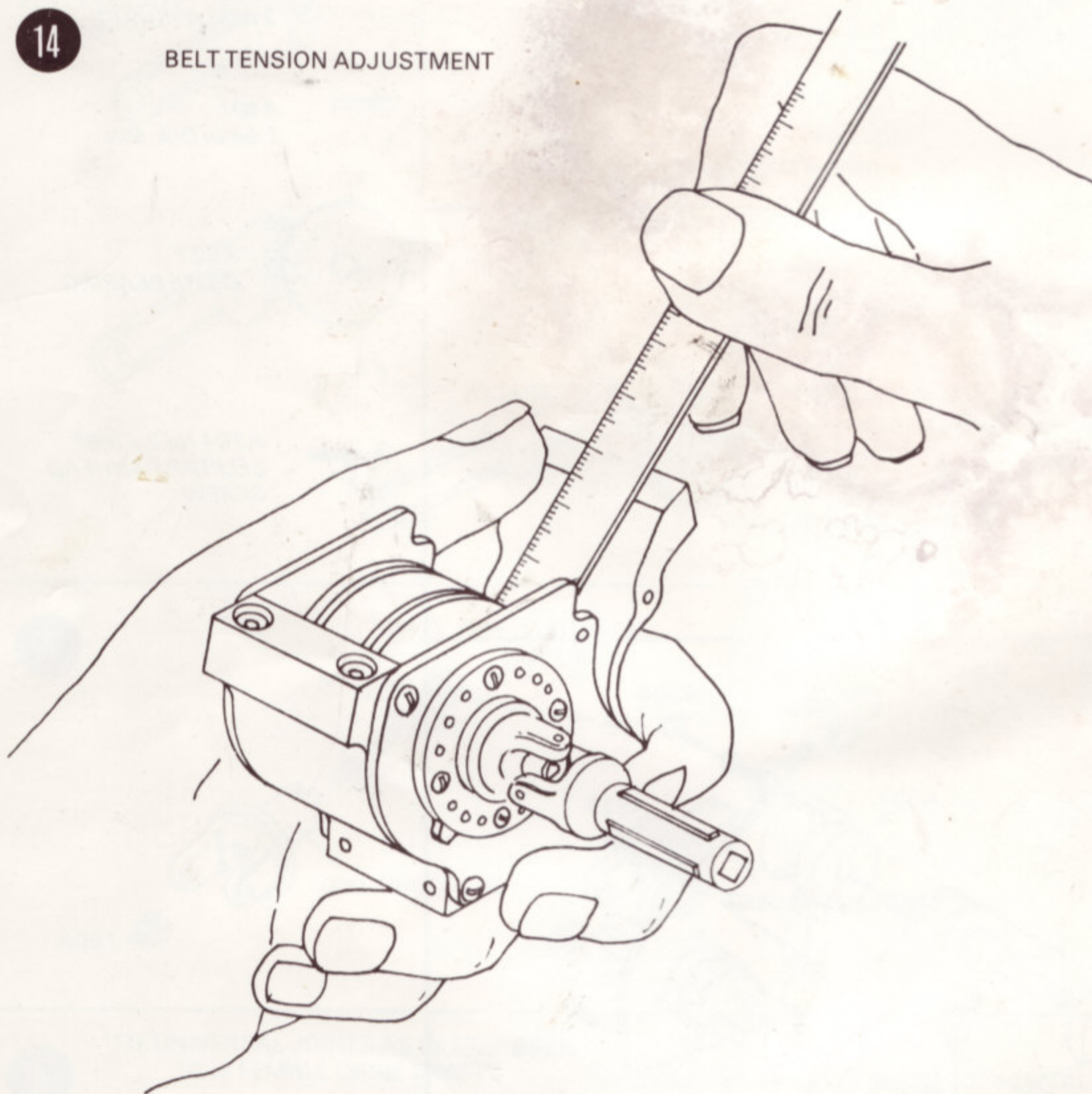

BELT TENSION ADJUSTMENT

SLIPPER CLUTCH

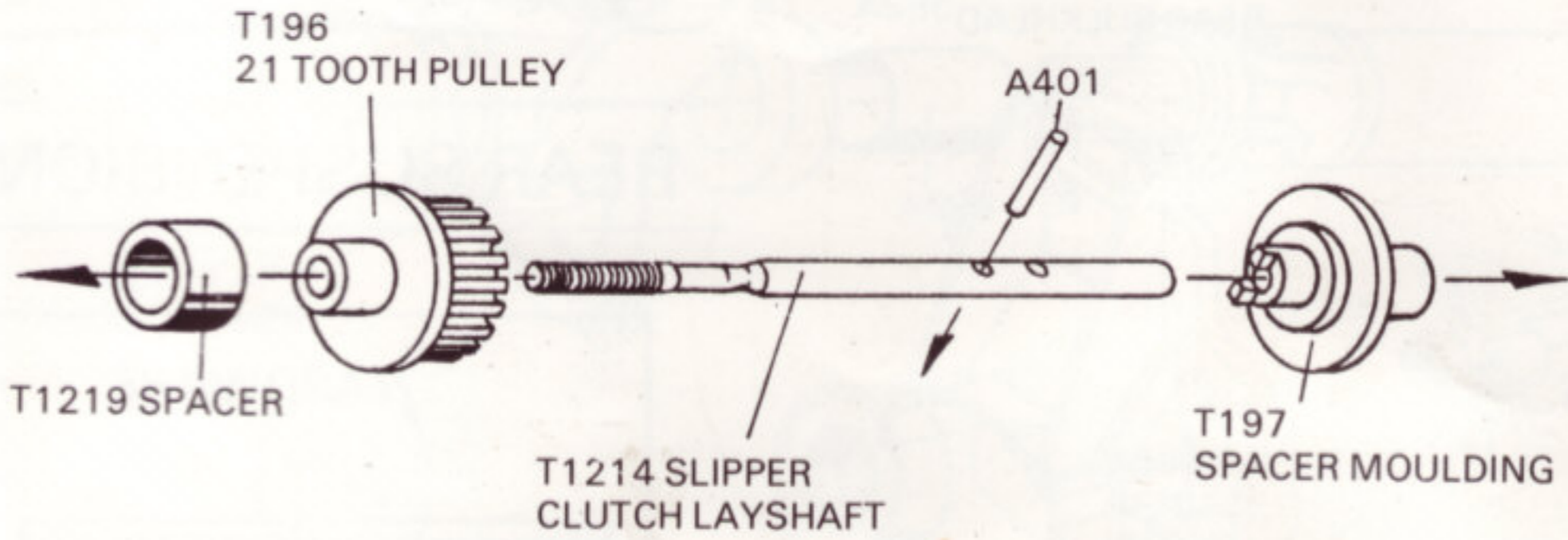

HARDWARE

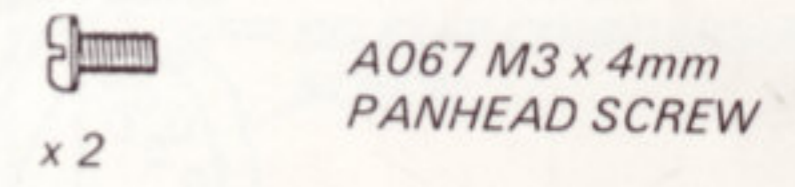
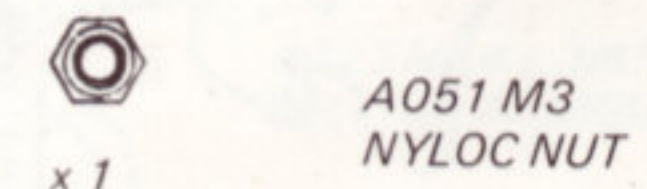
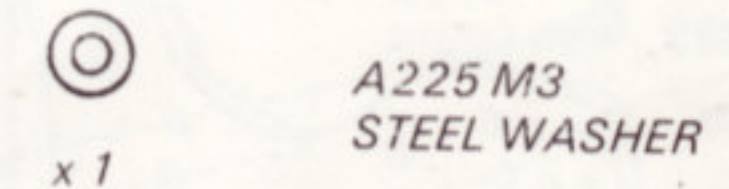
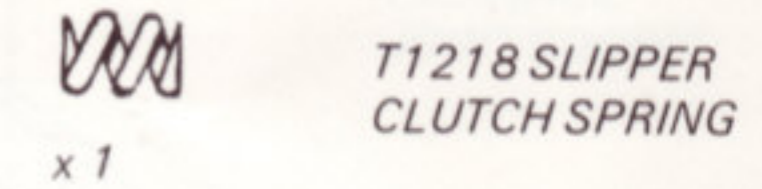
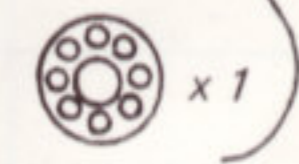
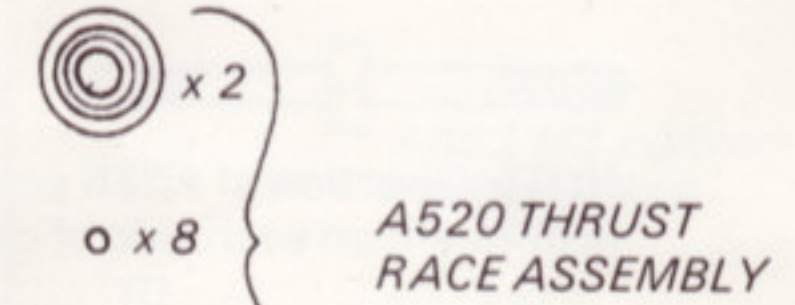
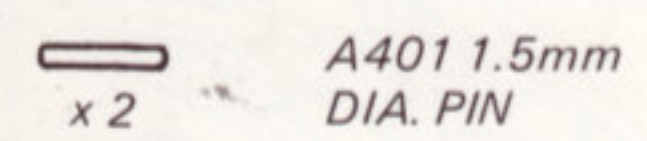
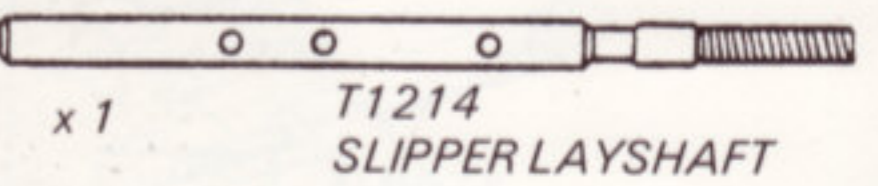
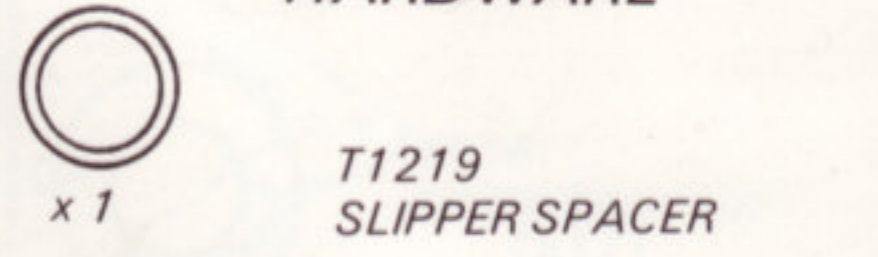

2

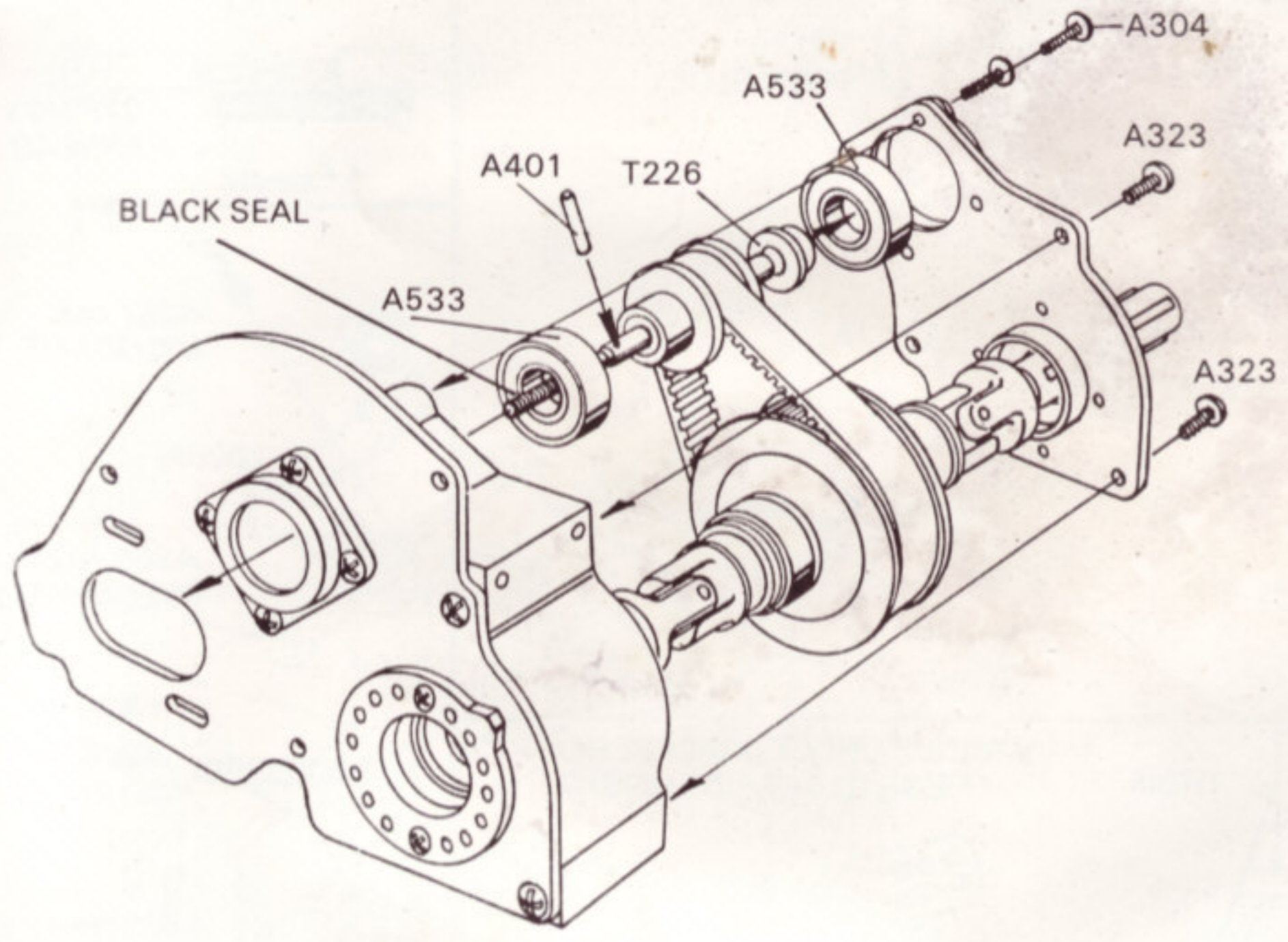

3

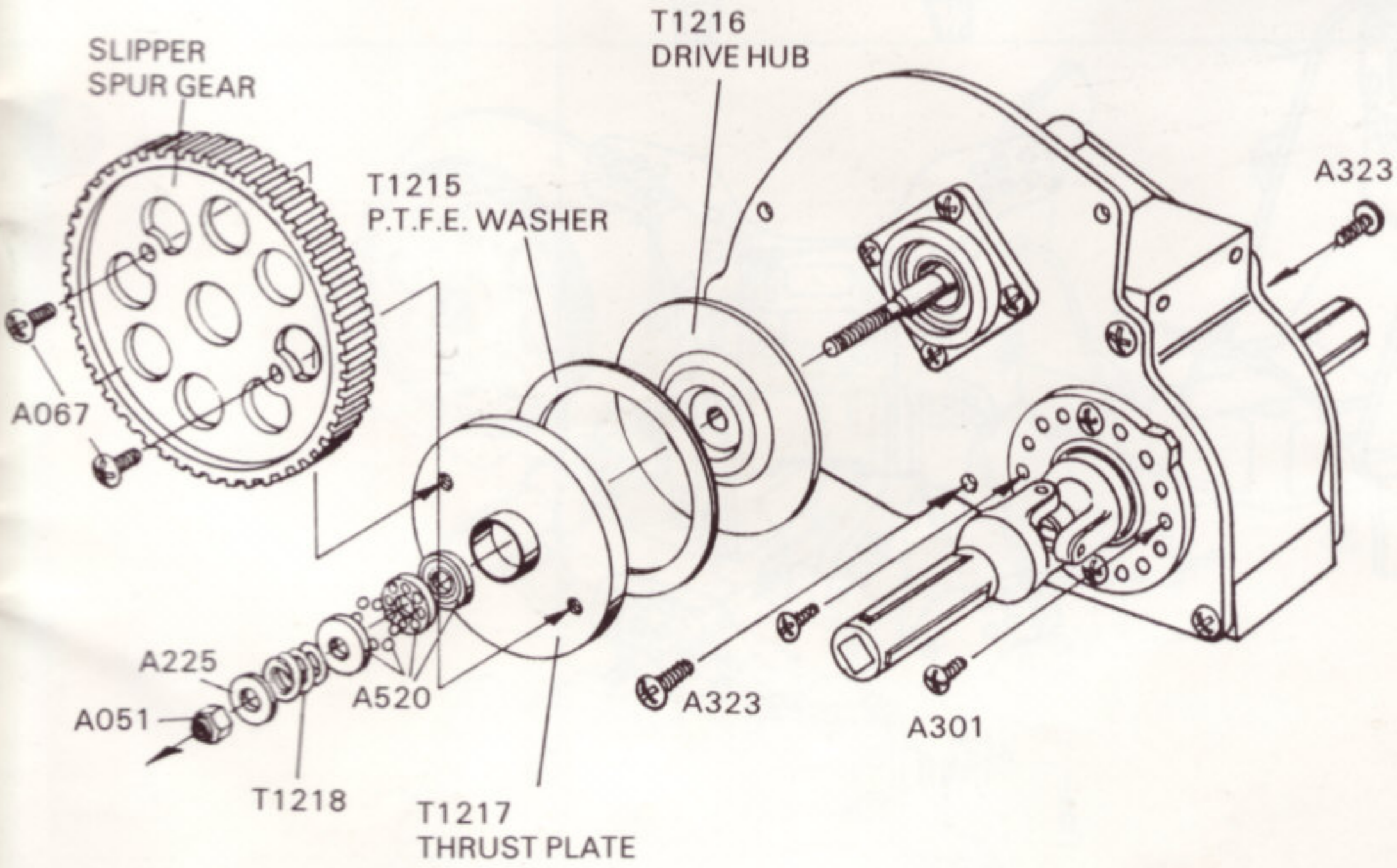

PART No.	SPARES No.
T1214	U1214N
A401	U856Z
T1219	U856Z
T1218	U856Z
A225	U856Z
A051	U856Z
A067	U856Z
A533	U724X
A520	U730D
T1216	U855Y
T1217	U855Y
T1215	U856Z

1

REAR SUSPENSION

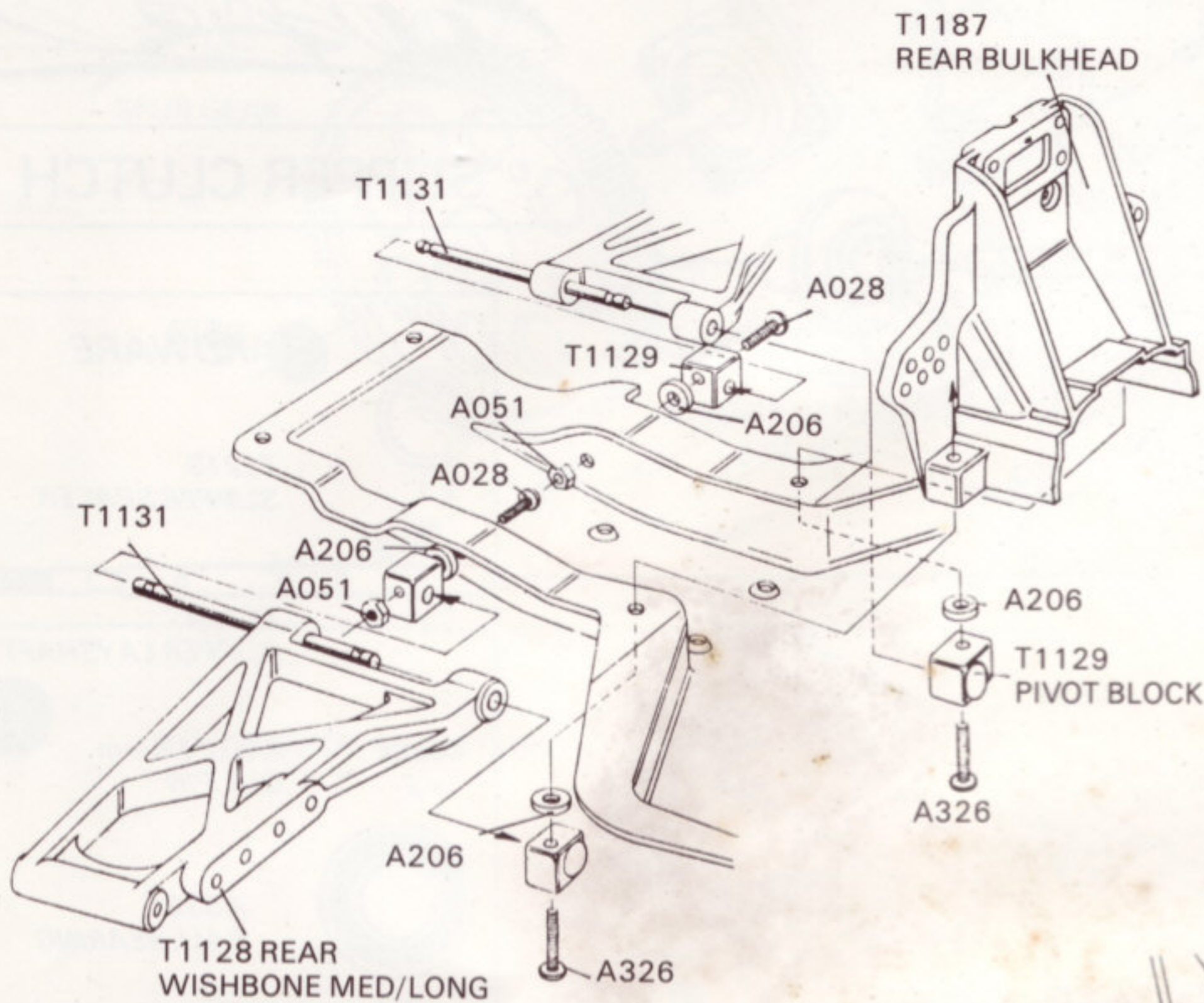

NOTE: Direction of A028 screws in chassis is different on each side of car.

HARDWARE

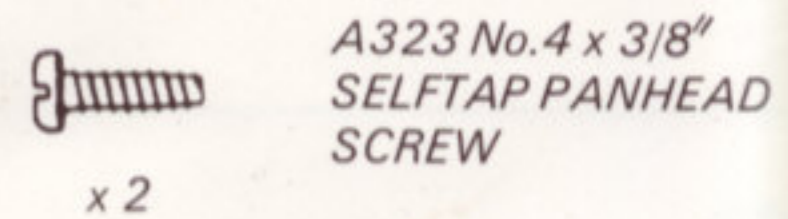
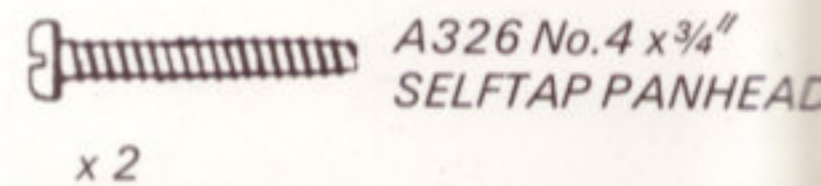
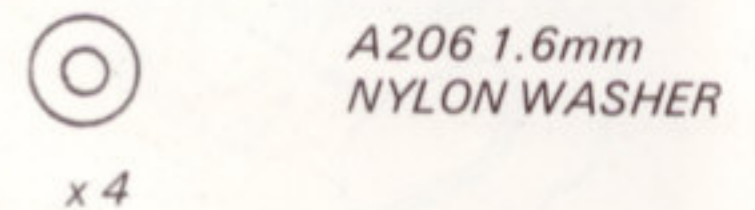
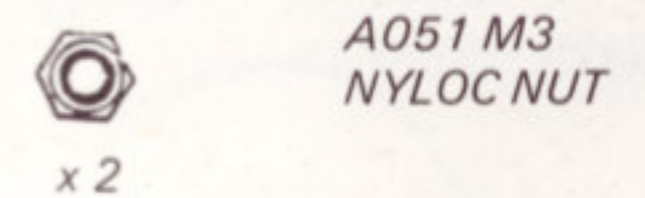
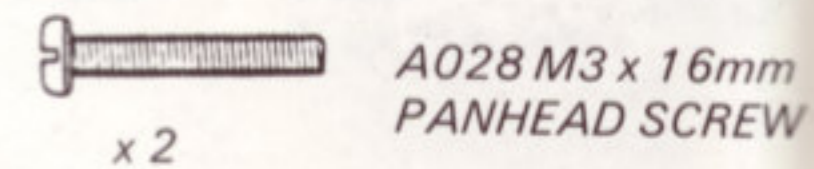
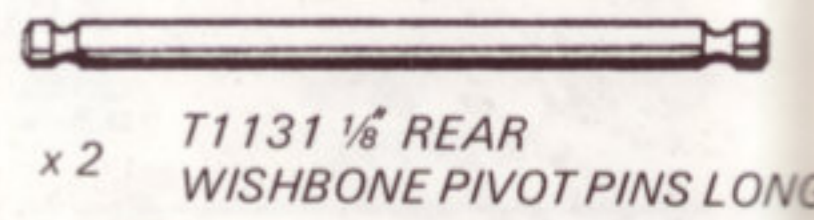

VARIOUS SHOCK BRACKET HEIGHTS USE TO SET RIDE HEIGHT

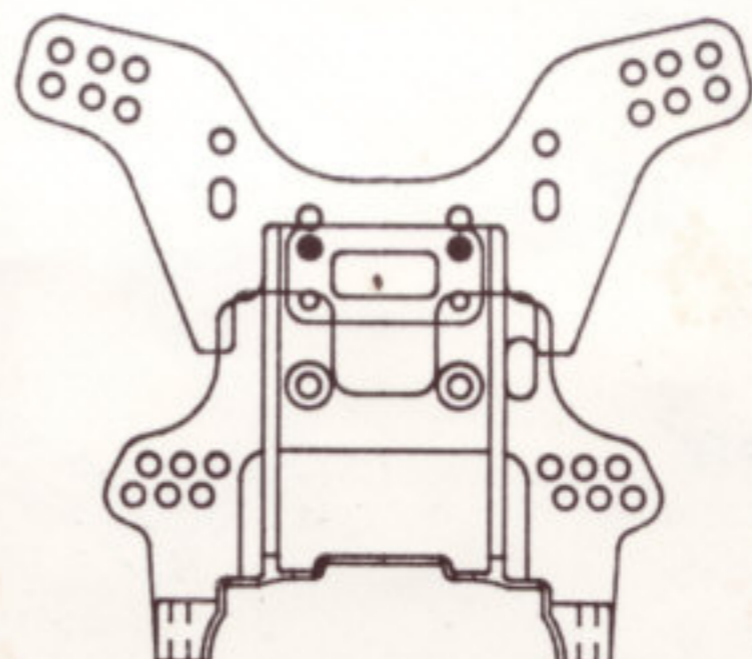
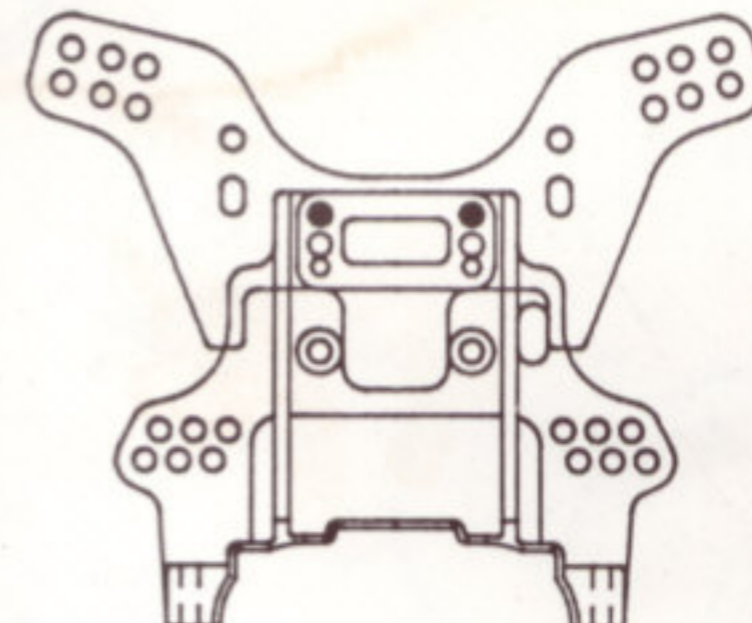
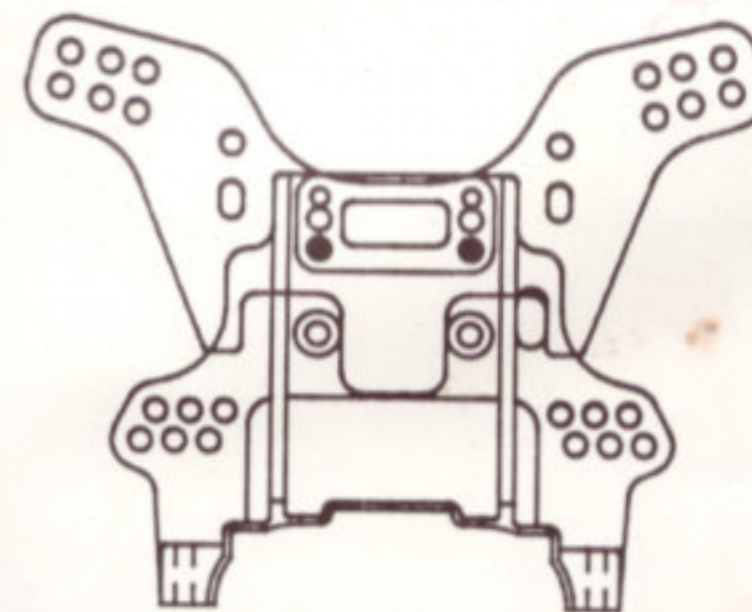
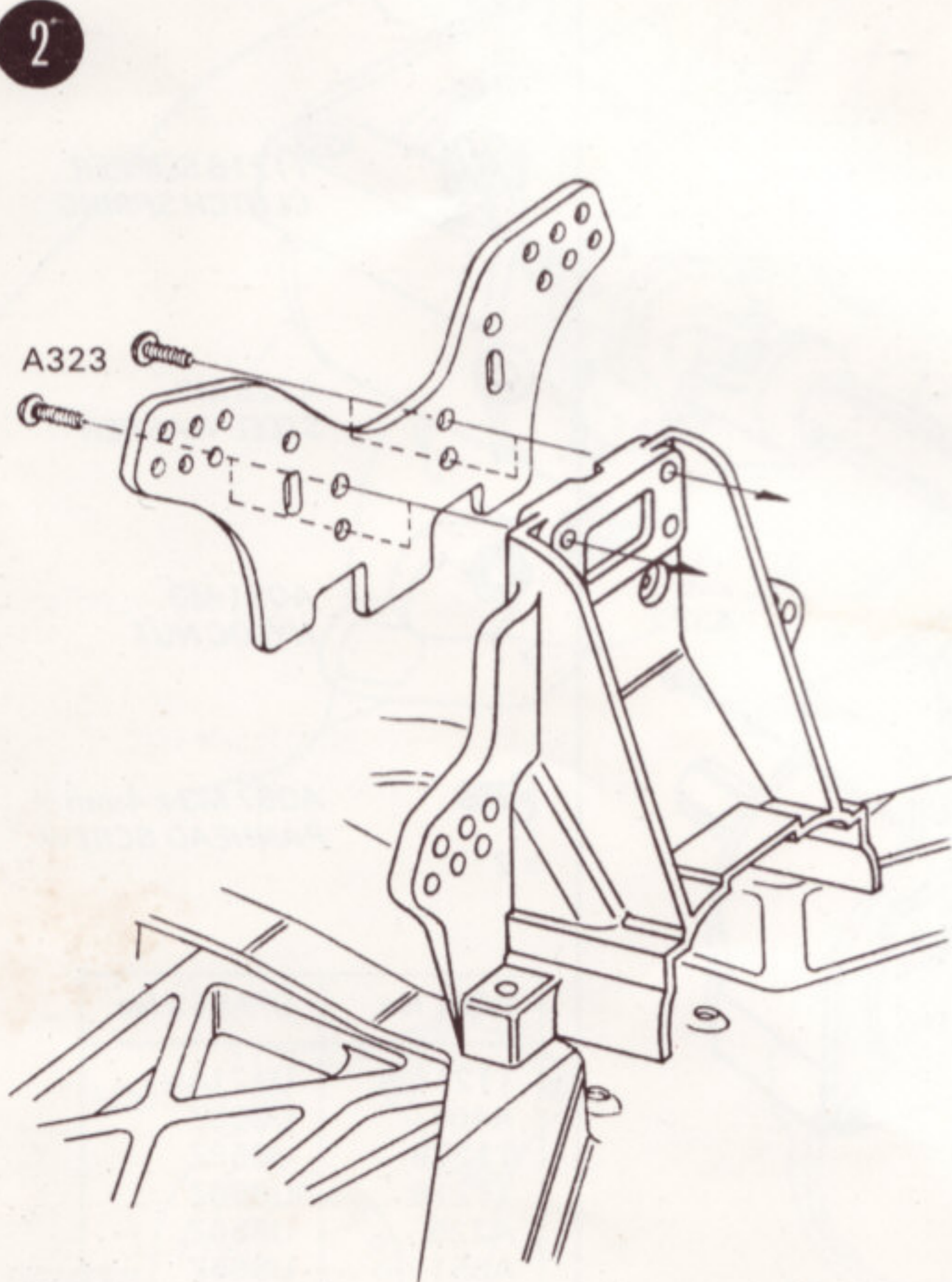

3

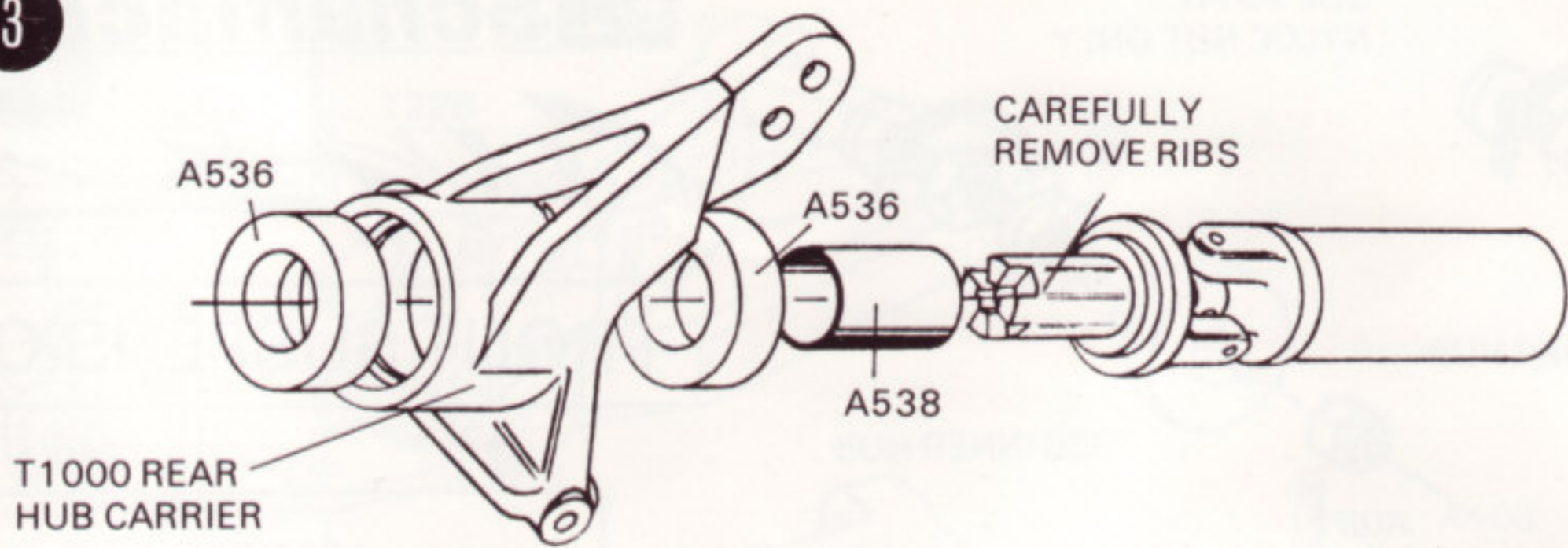

T1000 REAR HUB CARRIER

A536

A536

CAREFULLY REMOVE RIBS

A538



A533



A533

A533 BALLBEARINGS REPLACE OILITES + SLEEVES IN TEAM + RACING KITS.

REAR SUSPENSION

HARDWARE



A536 OILITE BEARING

x 4



A538 BEARING SLEEVE

x 4



A051 M3 NYLOC NUT

x 4



T1206 BALL STUD LONG

x 2

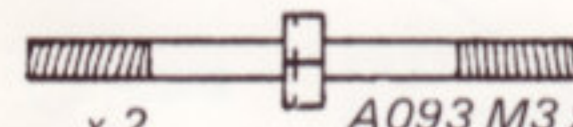

A093 M3 x 35mm TURNBUCKLE

x 2



A077 M3 GRUB SCREW

x 2

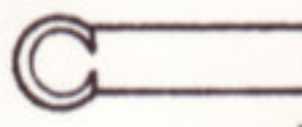

T320 BALL JOINT SOCKET

x 4

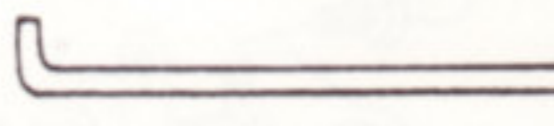

A417 PIVOT PIN

x 2

4

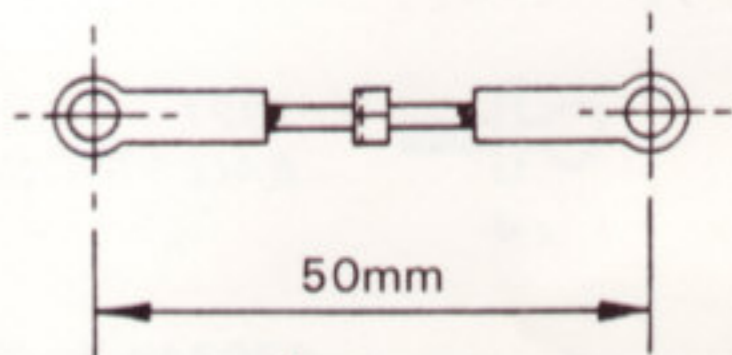

50mm

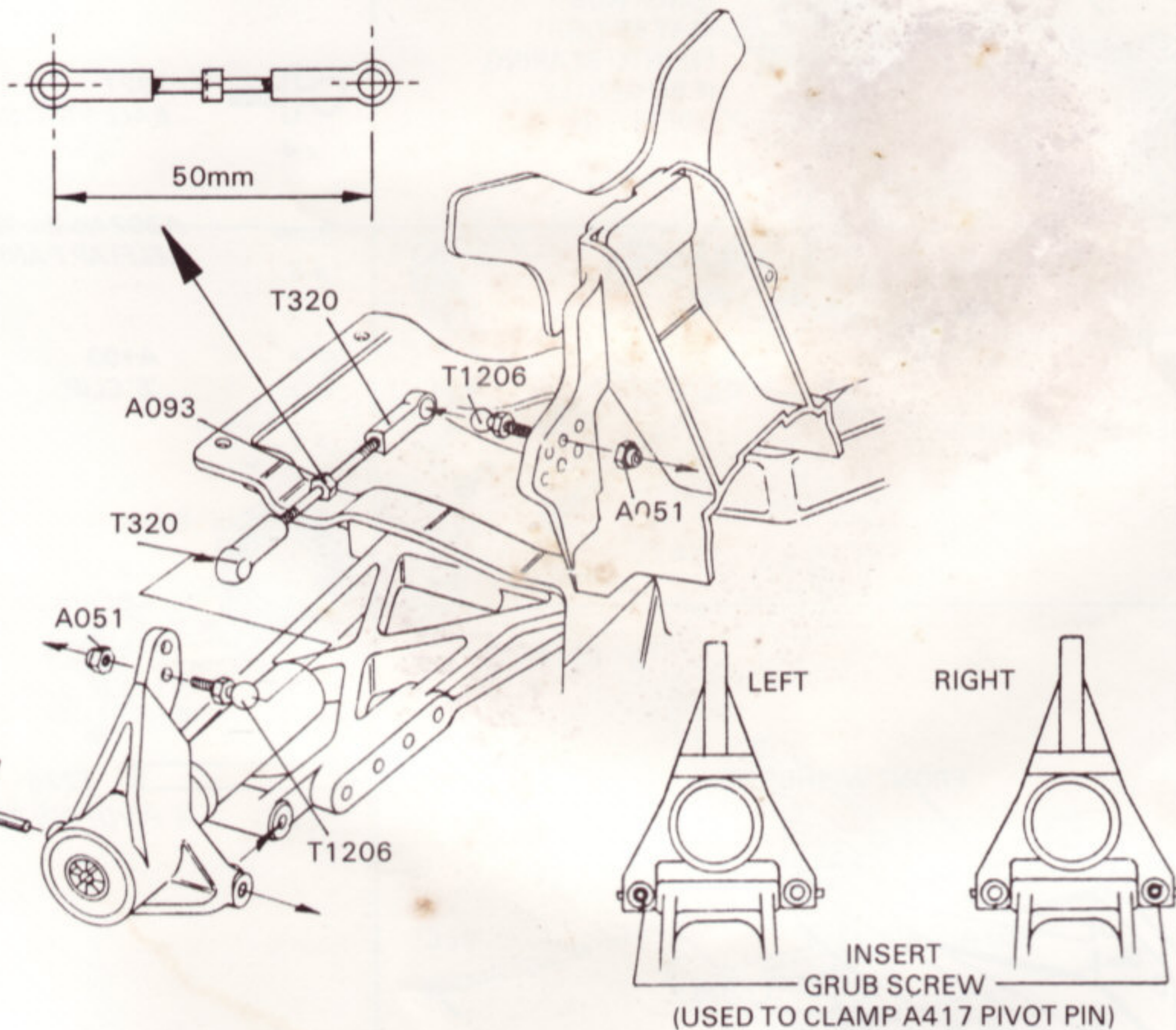

INSERT GRUB SCREW (USED TO CLAMP A417 PIVOT PIN)

5

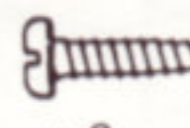
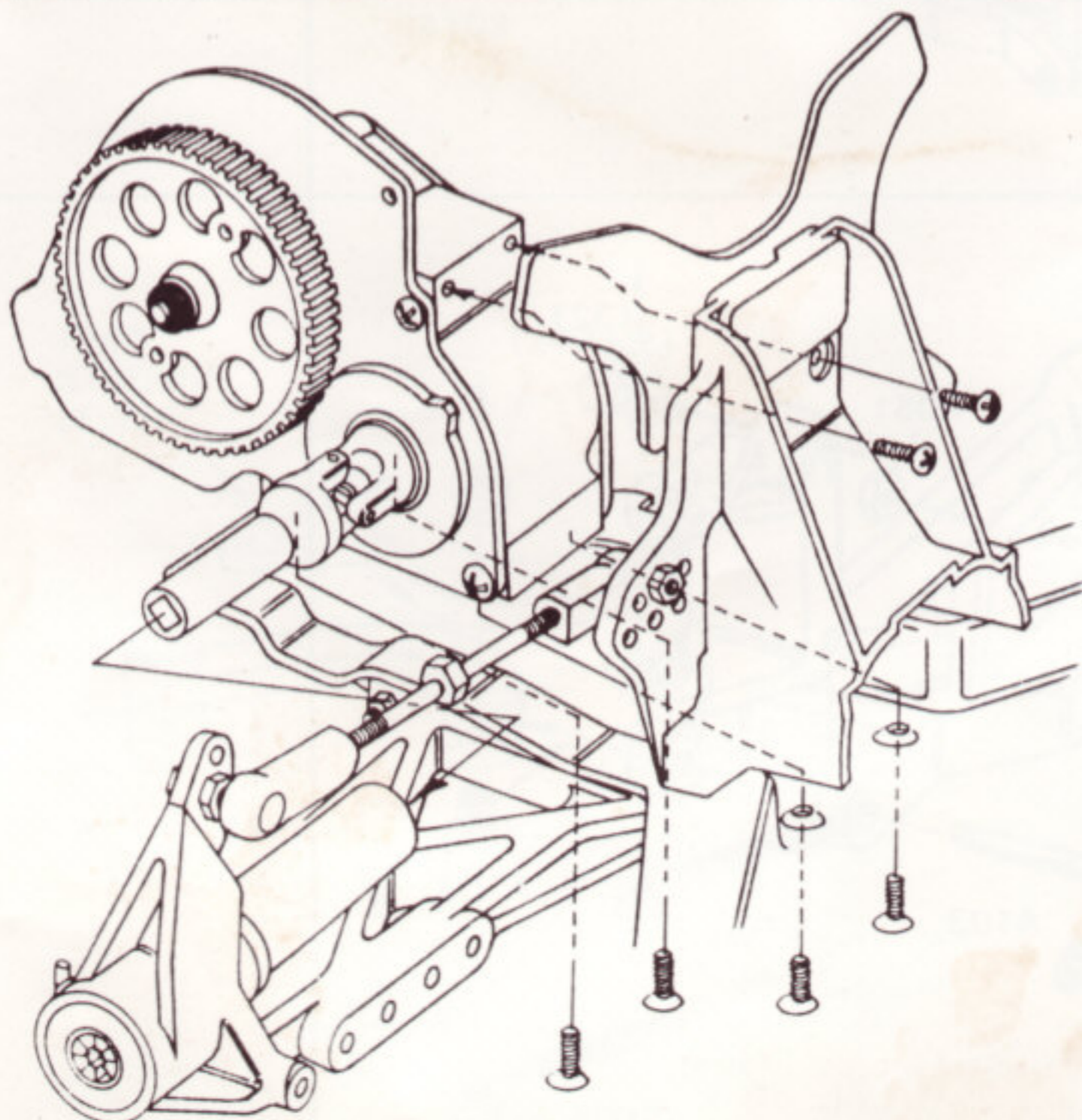

A323 No.4 x 3/8" SELFTAP PANHEAD SCREW

x 2



A333 No.4 x 3/8" SELFTAP COUNTERSUNK SCREW

x 4

PART No.	SPARES No.
A533	U724X

1

USE TO FIT
NYLOC NUT ONLY

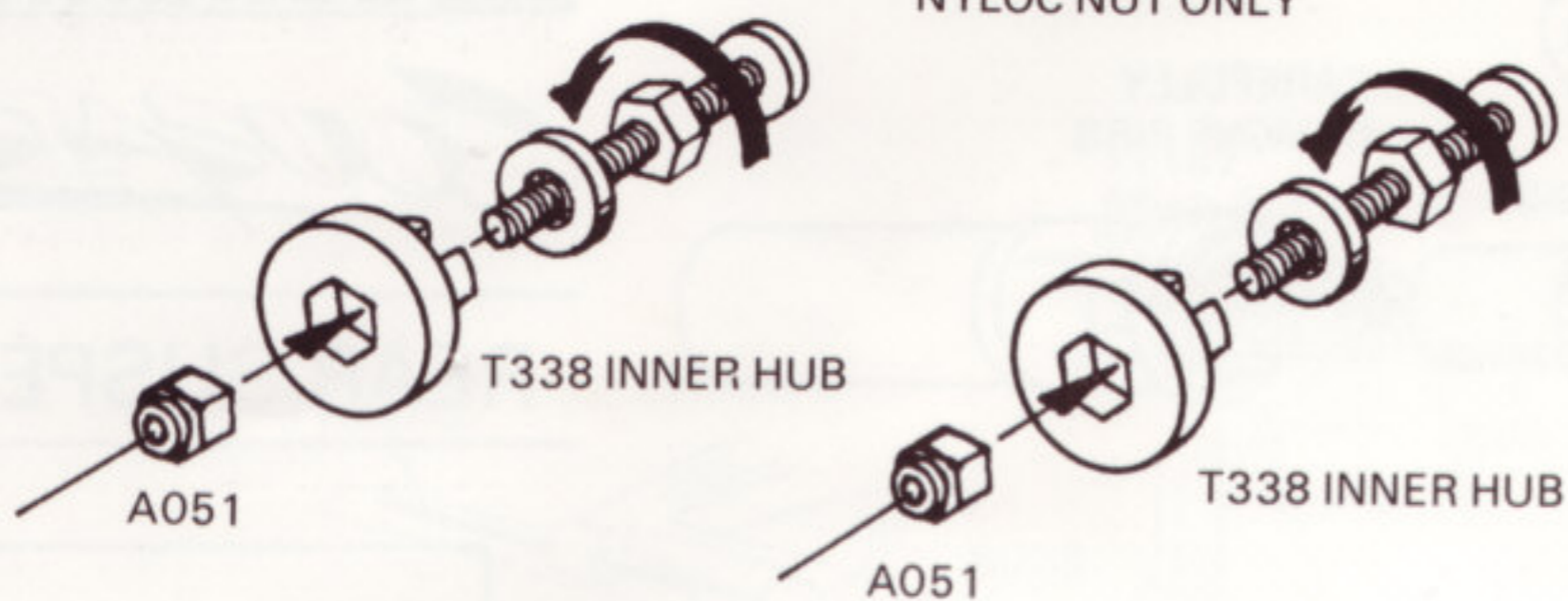

FRONT SUSPENSION

HARDWARE



A051 M3
NYLOC NUT

x 2



T321
BALL STUD SHORT

x 4

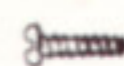

A302 No.2 x 1/4"
SELFTAP PANHEAD

x 8



A103
'E' CLIP

x 4



A533
BEARING

x 2

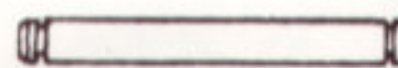

T228

x 2

1/8" PIVOT PIN SHORT

2

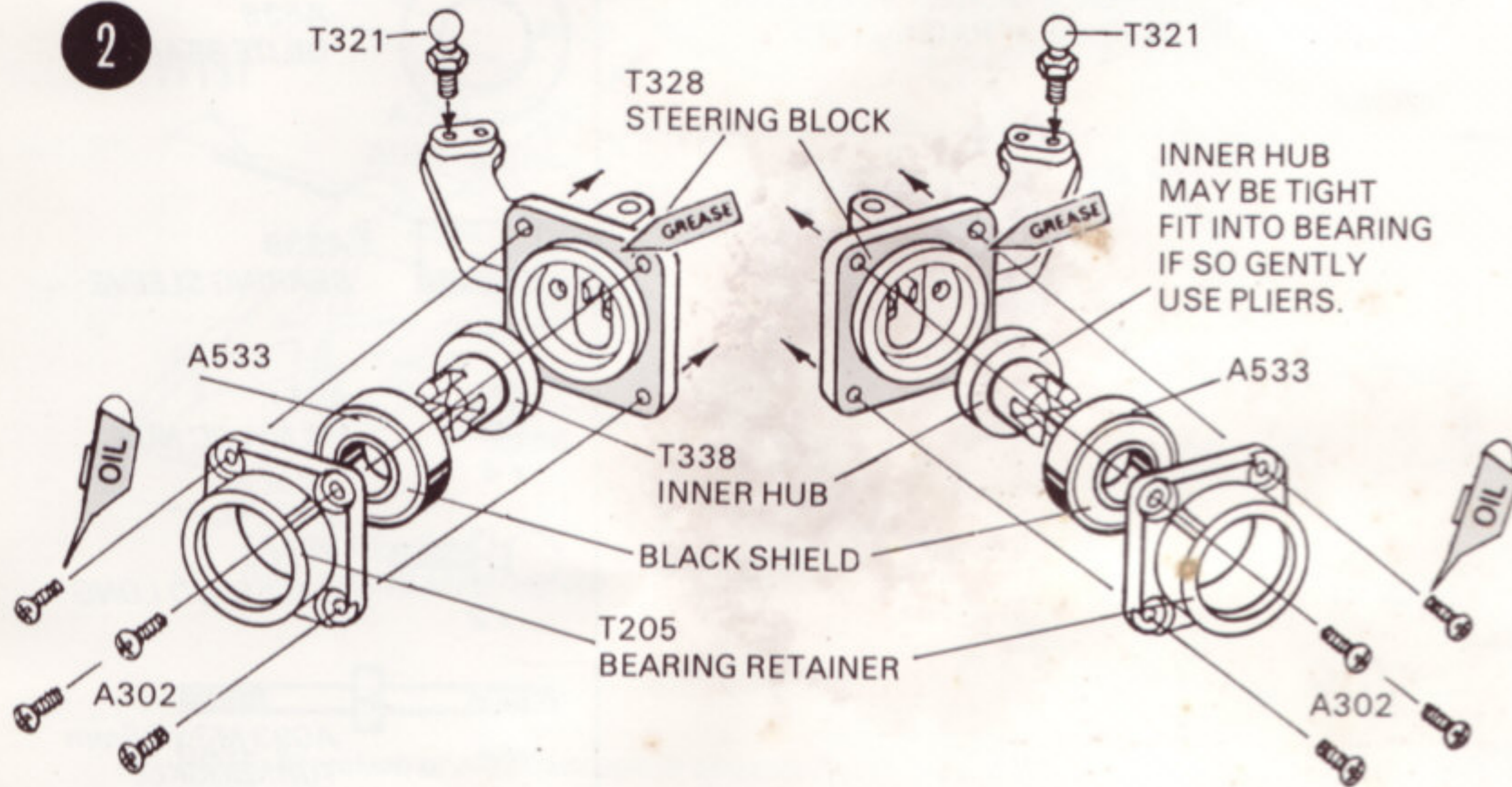

INNER HUB
MAY BE TIGHT
FIT INTO BEARING
IF SO GENTLY
USE PLIERS.

3

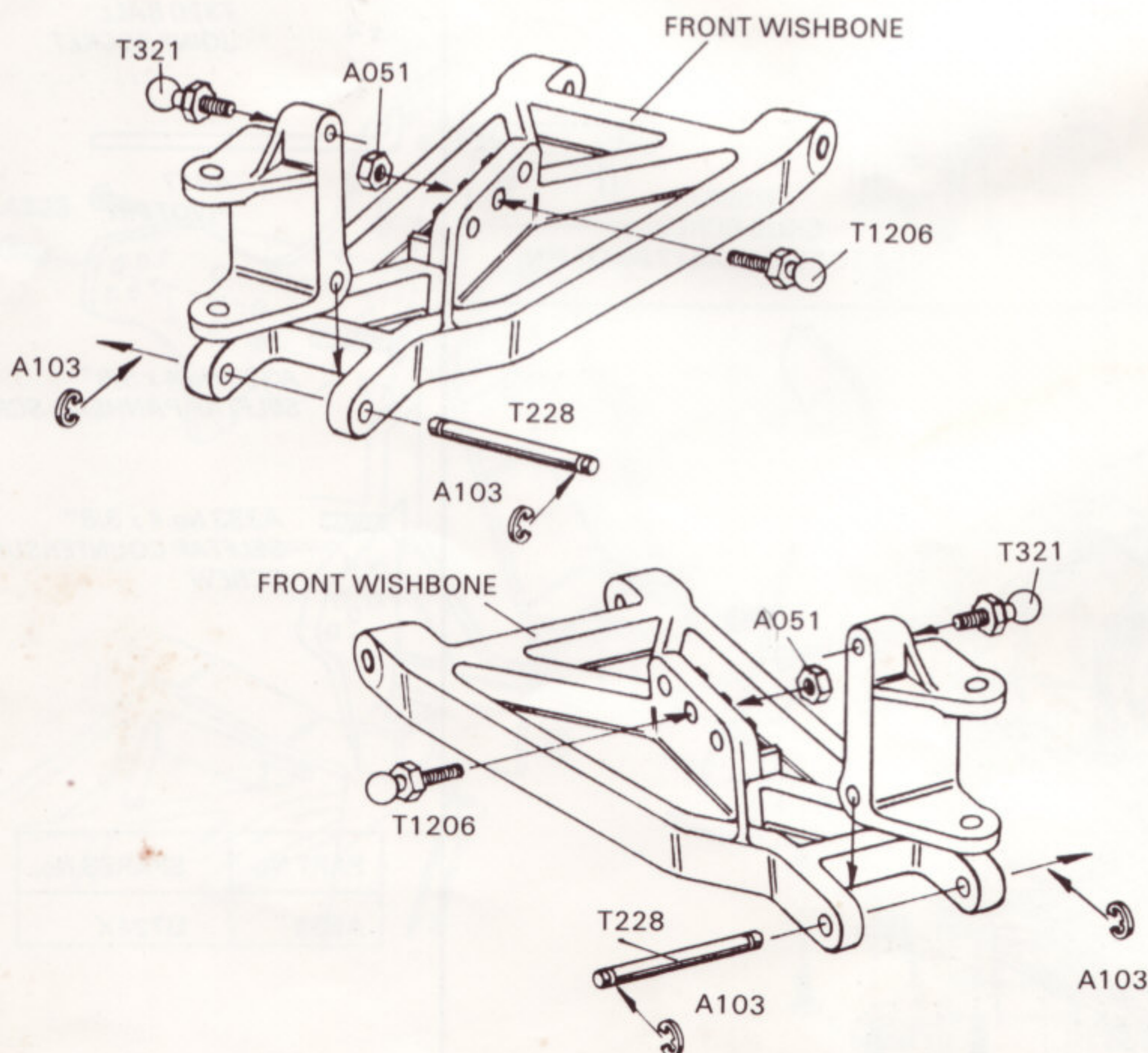

FRONT SUSPENSION

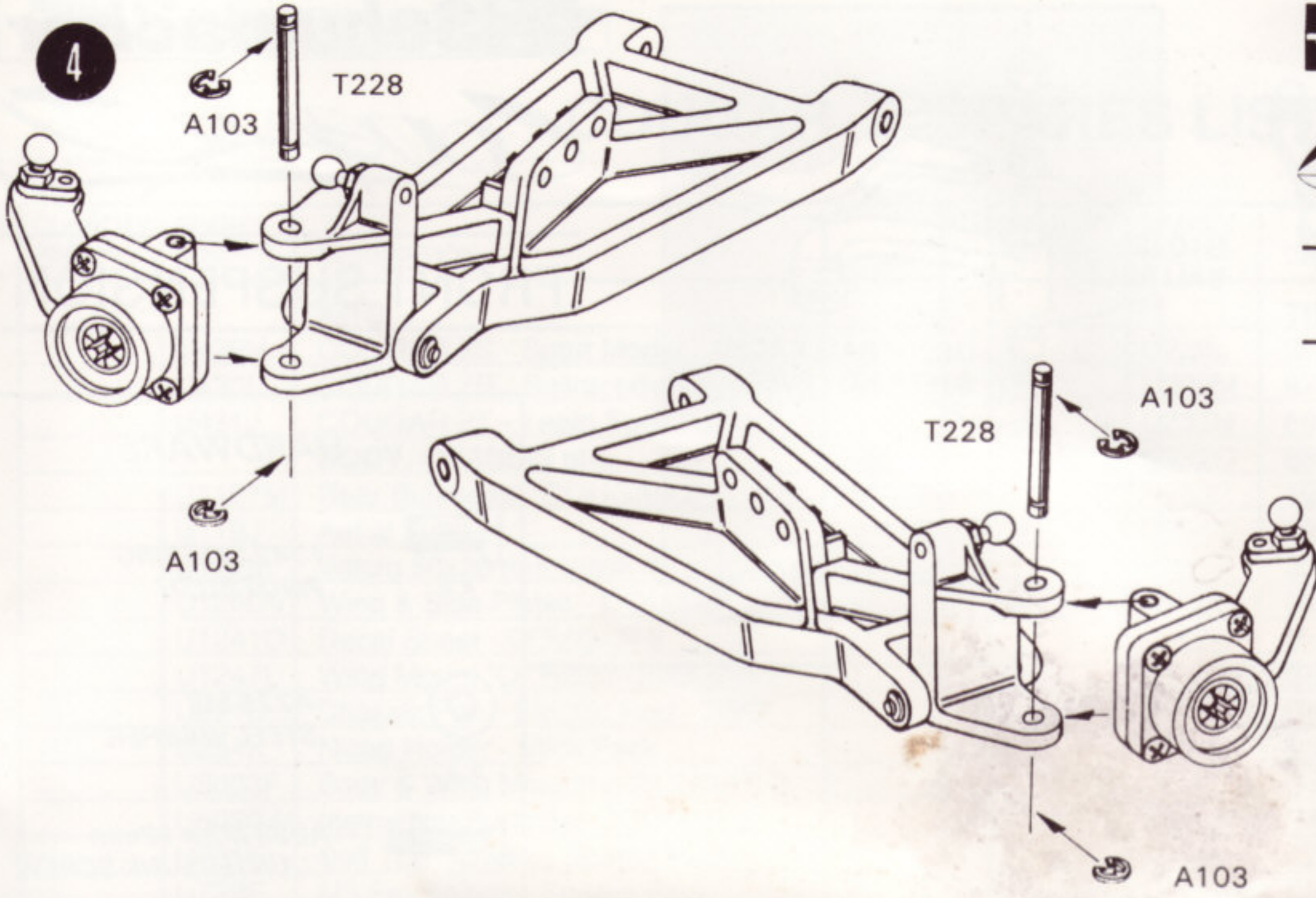

HARDWARE

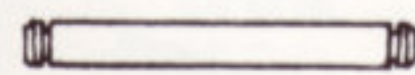
 T228 1/8" PIVOT PIN SHORT
x 2

 A103 'E' CLIP
x 8

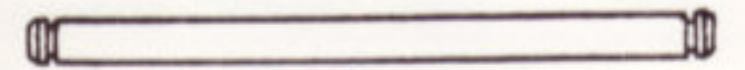
 T339 1/8" PIVOT PIN LONG
x 2

 T242 STEERING PIVOT
x 2

 T321 BALL STUD
x 2

 A225 M3 STEEL WASHER
x 2

 A032 M3 x 6mm CHEESEHEAD SCREW
x 2

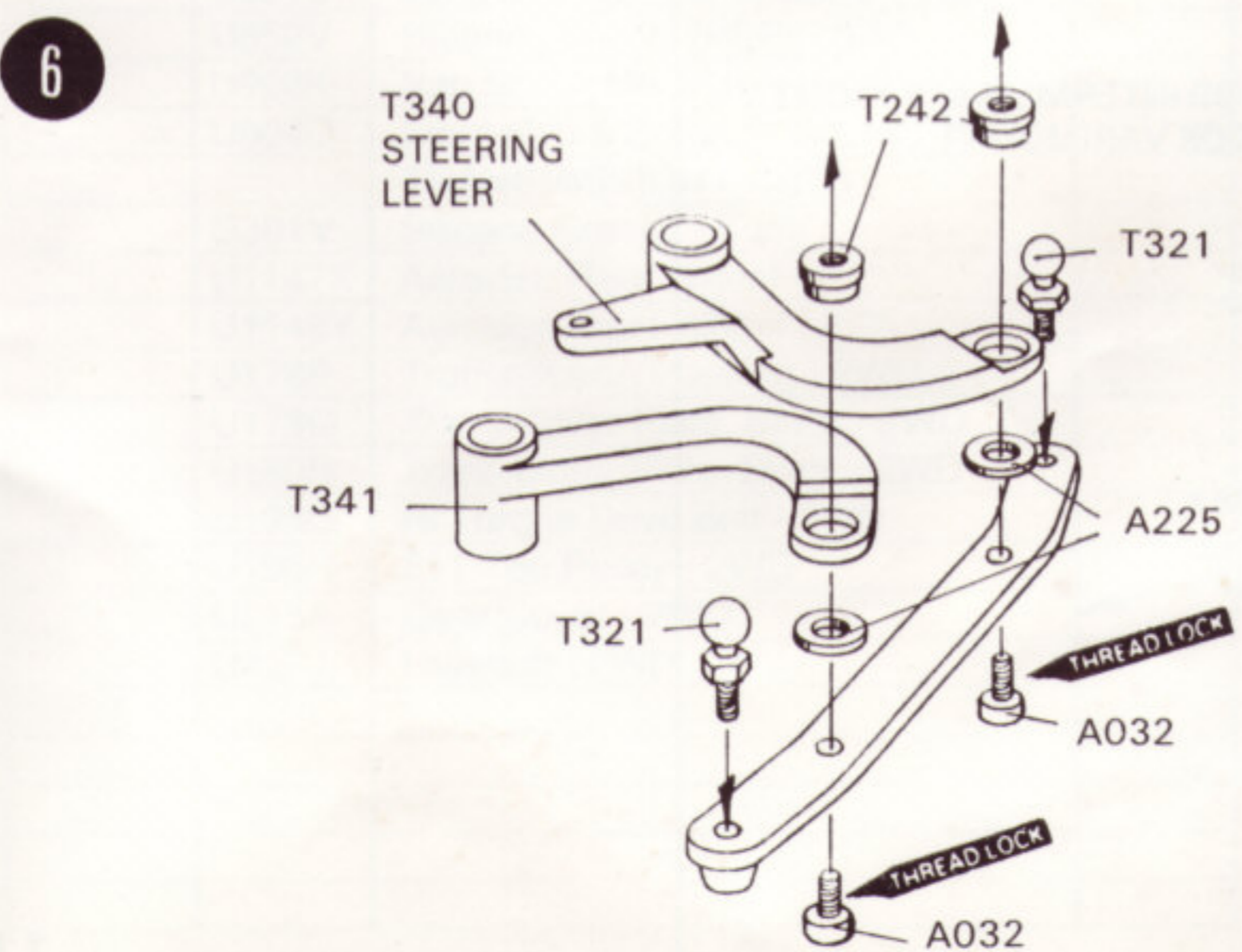
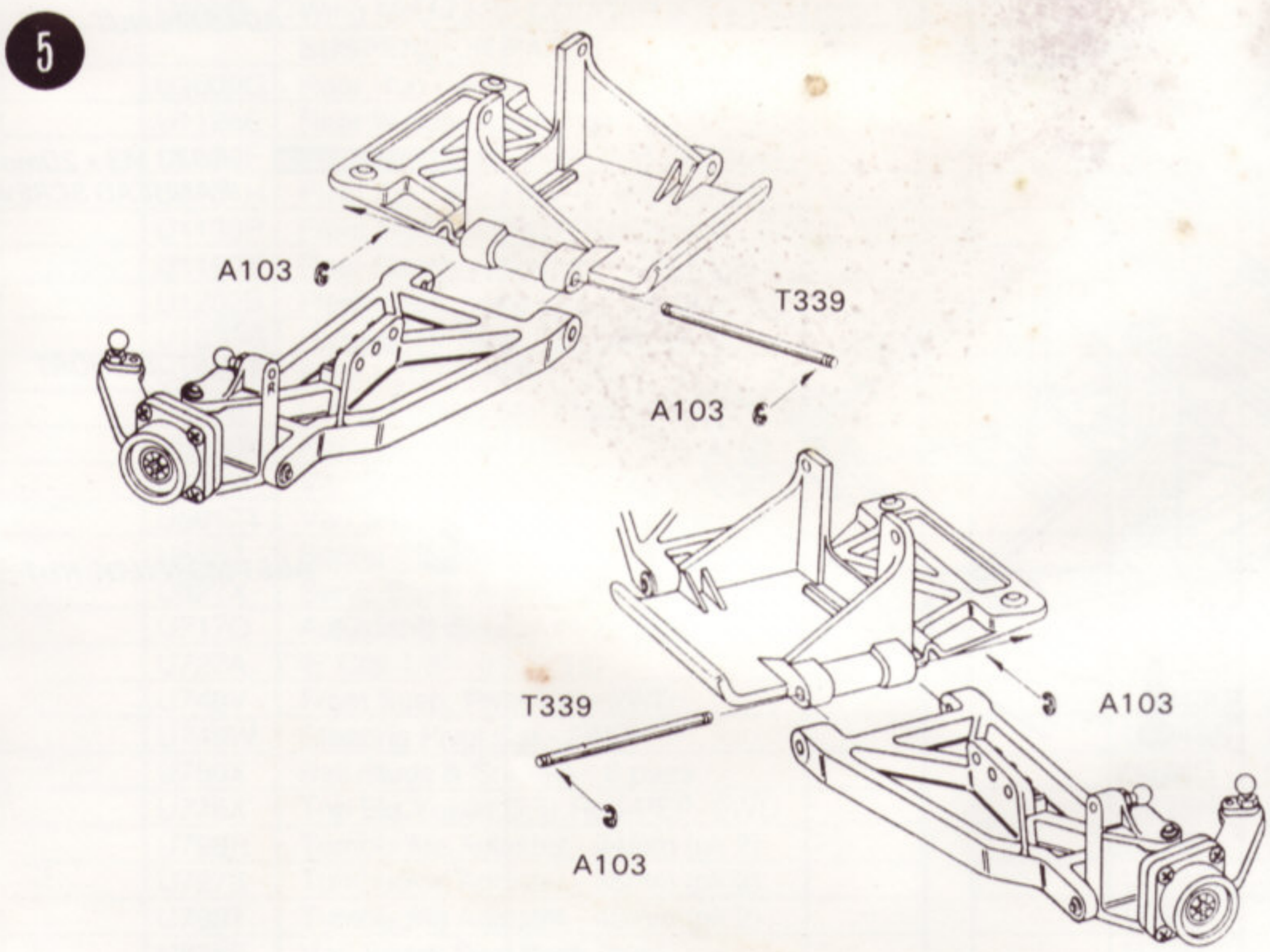





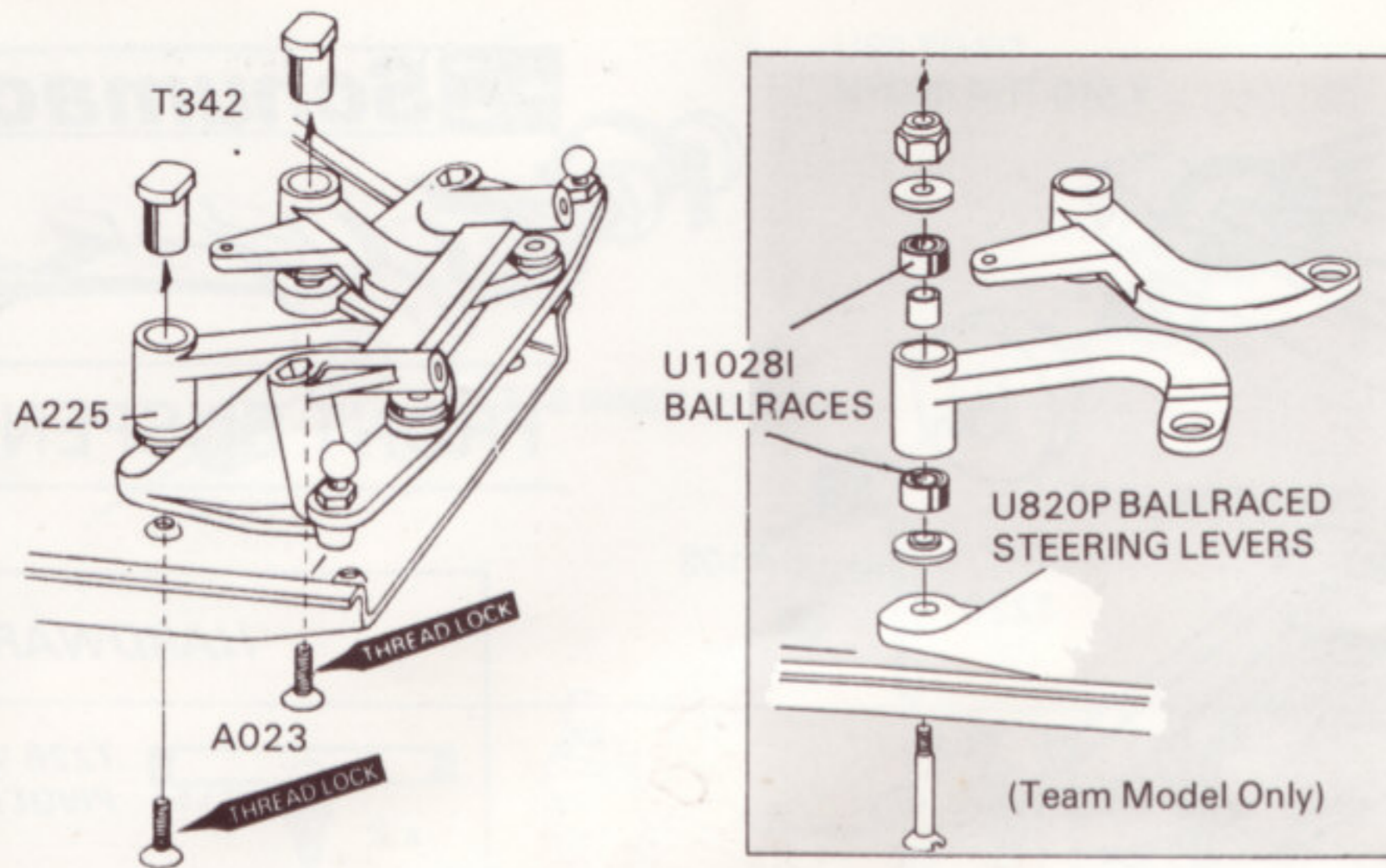

FRONT SUSPENSION

7



HARDWARE

-  x 2 **T342 STEERING PIVOT BUSH**
-  x 2 **A225 M3 STEEL WASHER**
-  **A023 M3 x 12mm COUNTERSUNK SCREW**
-  x 2 **A048 M3 NUT**
-  x 2 **A033 M3 x 20mm PANHEAD SCREW**
-  x 2 **T321 BALL STUD SHORT**
-  x 2 **A051 M3 NYLOC NUT**

8

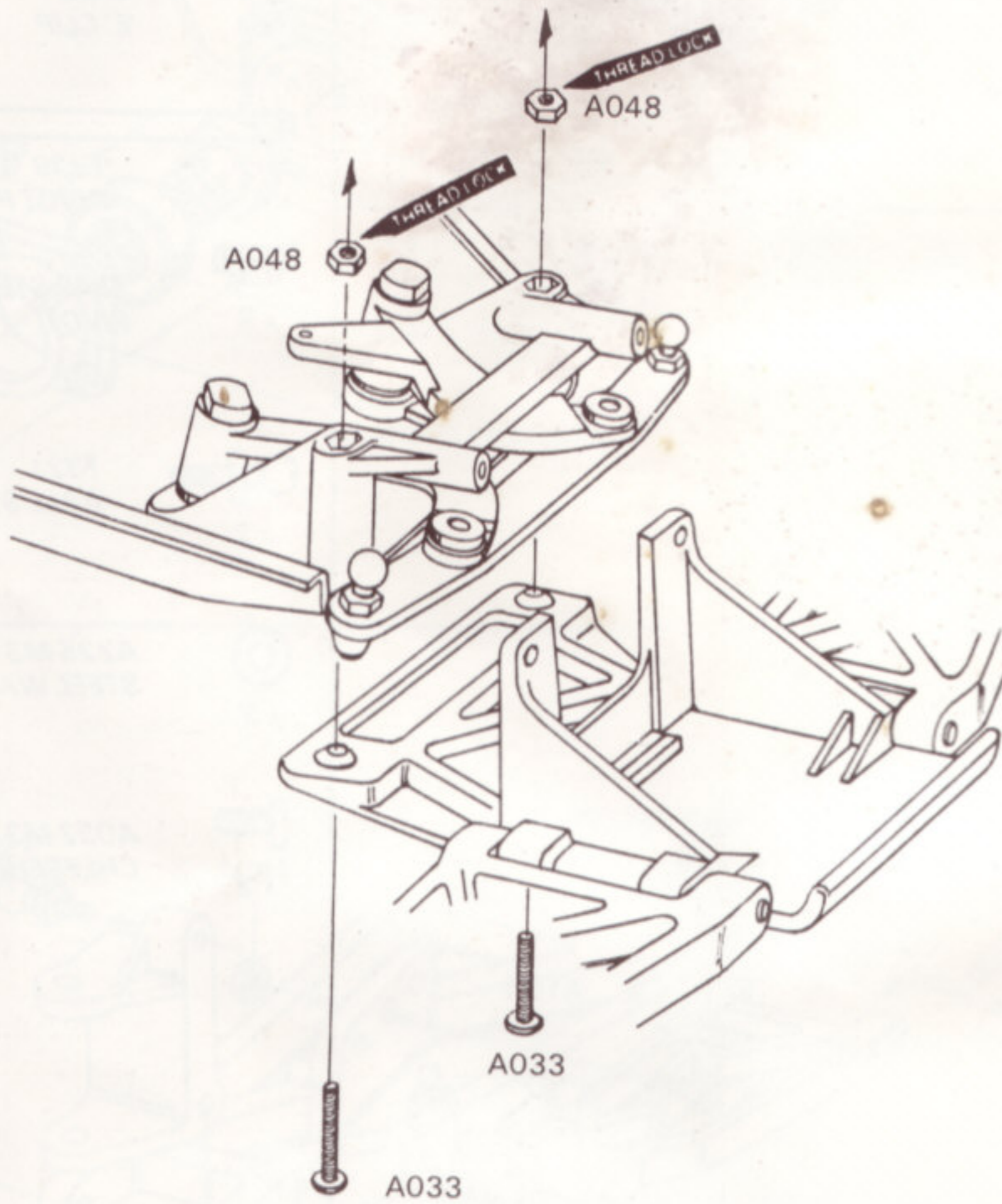

9

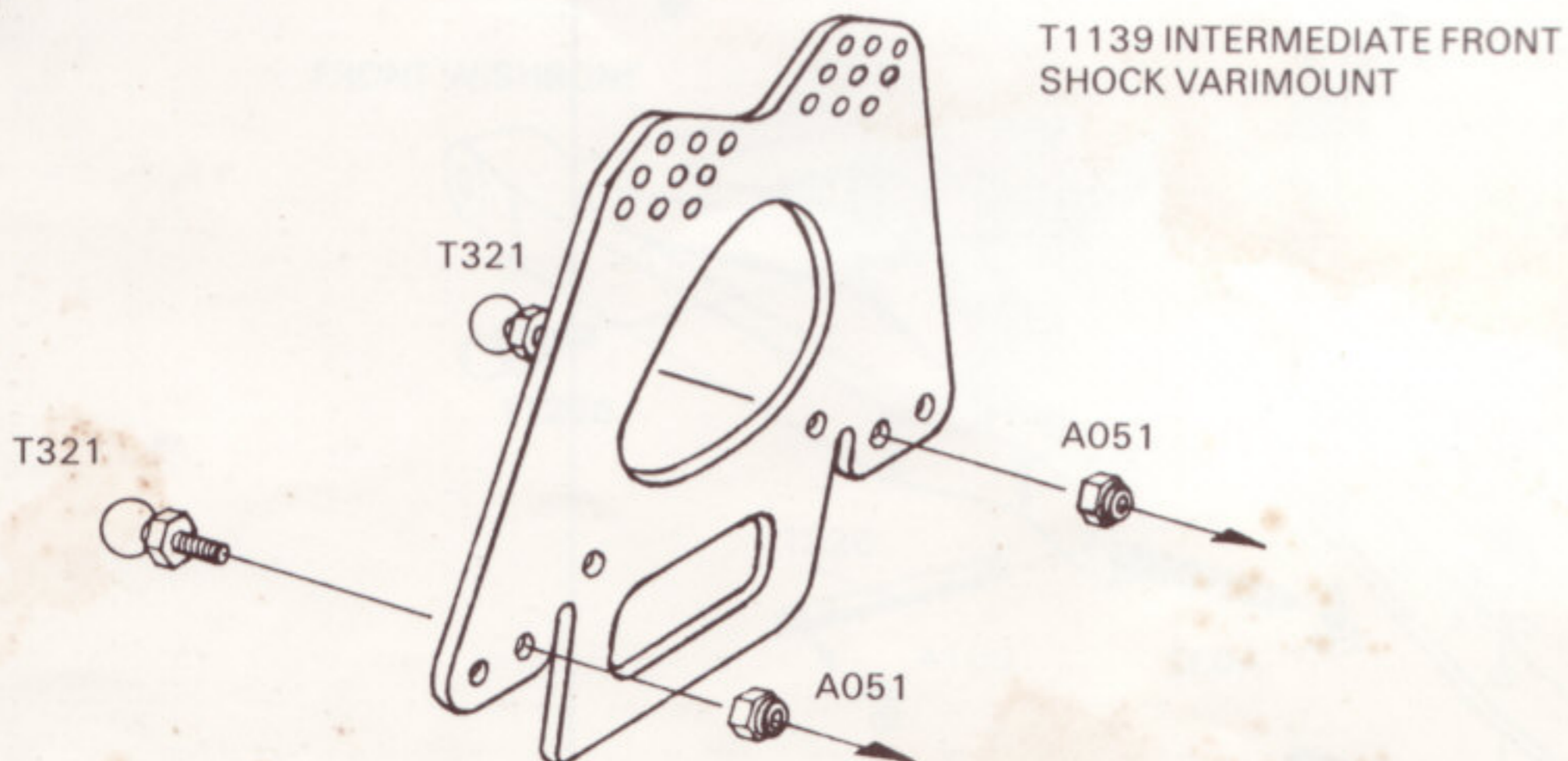

COUGAR 2 SPARES LIST.

QUANTITY REQUIRED	SPARES NUMBER	DESCRIPTION
		KIT'S
	U429H	COUGAR 2S - Sport Model
	U430I	COUGAR 2R - Ballraced+Slipper
	U431J	COUGAR 2T - Team Specification
		BODY, CHASSIS etc.
	U1187M	Rear Bulkhead - COUGAR 2
	U119J	Aerial Tube
	U122M	Velcro 50x20 mm (pack 4)
	U1240N	Wing & Side Plates - COUGAR 2
	U1241O	Decal Sheet - COUGAR 2
	U1247U	Wing Mount "O" Rings-COUGAR 2
	U221D	Chassis Pan - Electric Red - 2WD
	U254K	Nicad Holder - Stick Pack
	U5003F	Body & Wing Moulding-COUGAR 2
	U5020W	Instruction Book Set-COUGAR 2
	U731E	Self Tap Screws - Spares Pack
	U732F	M3 Fastenings - Spares Pack
	U779A	Servo Tape - 1 Metre Roll
	U832B	Wing Mount Kit - COUGAR 2
		SUSPENSION PARTS
	U1000G	Rear Hub Carrier - Adj. 2&4WD (pr)
	U1128E	Rear W'bone-Med/LngW/B-1/8"Pin(pr)
	U1129F	Pivot Block 1/8" Rear W/B 2WD(pk4)
	U1131H	Pivot Pin 1/8" - Rear Wishbone(pr)
	U1139P	Front Medium Shock Vari Mount - C2
	U1199Y	Rear Shock Varimount - COUGAR 2
	U1202B	Piston Rod. Long - Vari Shock (pr)
	U1233G	Piston Rod. Med - Vari Shock (pr)
	U1246T	Rear Hub Pivot Pin - 2mm (pr)
	U322E	Lower Front Susp. Plate - 2WD
	U5008K	Front Suspension Set - COUGAR 2
	U5013P	Vari Shock Absorbers - Medium (pr)
	U5017T	Vari Shock Absorbers - Long (pr)
	U613J	Spring Stop & Spacer Moulding
	U627X	Servo Saver Assembly
	U717Q	Adjustable Servo Link (2 sets)
	U727A	'E' Clip 1/8" - (pack 10)
	U748V	Front Susp. Pivot Set - 2WD
	U749W	Steering Pivot Set - 2WD
	U750X	Ball Studs & Sockets - 8 pairs
	U776X	Top Bkt.Yokes.C.Tr.Rod-PEP- 2WD
	U796R	Turnbuckle.Adjuster - 24mm (pk 2)
	U797S	Turnbuckle Adjuster - 35mm (pk 2)
	U798T	Turnbuckle Adjuster - 45mm (pk 2)
	U835E	Vari Shock Seal Pack (pair)
	U847Q	Front Wishbones -PEP- COUGAR 2
	U851U	Long Ball Studs & Sockets - 8 prs
	U852V	Steering Levers (PEP) - 2WD
	U900K	Vari Shock Mouldings (pr)
	U904O	Front Hub & Steering Blocks - PEP
		TRANSMISSION PARTS
	G301V	Silicone Grease - Tube
	U1147X	Aerodisc Rear Wheel - 2.2"
	U1148Y	Aerodisc Front Wheel - 2.2"
	U178P	Transmission Housing - 2WD
	U179Q	Trans Cover Plate. Black - 2WD
	U180R	Trans Motor Plate. Black - 2WD
	U195G	Hi Torque Drive Belt - 2WD
	U196H	21T Top Pulley - 2WD
	U215A	Gear Cover - 2WD
	U227J	Layshaft - 2WD

QUANTITY REQUIRED	SPARES NUMBER	DESCRIPTION
		TRANSMISSION (cont)
	U229L	95T Whisper GEAR - 48 D.P.
	U230M	92T Whisper GEAR - 48 D.P.
	U231N	89T Whisper GEAR - 48 D.P.
	U232O	86T Whisper GEAR - 48 D.P.
	U233P	19T PINION - 48 D.P.
	U234Q	22T PINION - 48 D.P.
	U235R	25T PINION - 48 D.P.
	U236S	28T PINION - 48 D.P.
	U255L	Motor Guard - 2WD
	U517R	Bearing Housing Moulding
	U631B	Universal Joints Bag - (4 pcs)
	U704D	D/Shaft & Sealed Hub Set - 2WD
	U720T	Oilite Bearings-Trans - 2WD (set 4)
	U721U	Oilite Bearings - Wheel (pair)
	U722V	'O' Ring 1/8" - (pack 10)
	U729C	Chrome Steel Balls 3mm (pk 30)
	U730D	Thrust Race 1/8" x 5/16"
	U849S	23mm Diff Pulley 51T - 2WD
	U850T	23mm Diff - Plain Bearings
	U857A	Screw,Locknut,Cover: 23mm Diff
		SPEED SECRETS 'CHASSIS'
	U1068W	Saddle Pack Strap - In Line F/G
	U355L	Graphite Chassis - COUGAR
	U743Q	Q.C. Saddle Pack Tray & Strap (pr)
	U744R	Q.C. Saddle Pack Strap (pk 2)
		SPEED SECRETS 'SUSPENSION'
	U1133J	Rear Wishbone-Med w/b-1/8"pin(pr)
	U1134K	Rear Wishbone-long w/b-1/8"pin(pr)
	U1248V	Ballbearing 1/8" x 1/4" (pk 2)
	U767O	Front Spring Tuning Set (4 prs)
	U768P	Rear Spring Tuning Set (5 prs)
	U820P	Ballraced Steering Lvr - 2WD
		SPEED SECRETS 'TRANSMISSION'
	U1028I	Ball Bearing 1/4" x 3/8" NF
	U1214N	Layshaft - New Slipper
	U1228B	Narrow Front Wheel - White (pr)
	U1243Q	23mm Pro-Diff Washers (pk 2)
	U1245S	23mm Pro-Diff Washer Carrier (pr)
	U224G	Front Wheel - Spoked White (pr)
	U225H	Rear Wheel - Spoked White (pr)
	U226I	Bush - Layshaft Bearing (4x8mm)(pr)
	U324G	95T Q.C. Slipper Gear - 48 D.P.
	U325H	92T Q.C. Slipper Gear - 48 D.P.
	U326I	89T Q.C. Slipper Gear - 48 D.P.
	U327J	86T Q.C. Slipper Gear - 48 D.P.
	U724X	Ball Races 8x16x5 - (pack 4)
	U762J	Ball Race 8x12mm FL. (pk 2)
	U780B	Ball Bearing 8x16x5 - (pack 8)
	U816L	Tungsten Carb. 3mm Diff Balls pk14
	U817M	Roller Drive Shaft (one piece)
	U818N	Ball Race Kit - Roller Drive Shaft (pr)
	U819O	Service Kit - Roller Drive Shaft
	U823S	Q.C. Slipper Clutch & Gear Set
	U843M	Ceramic Diff Balls dia 3mm(pk 14)
	U854X	Ballraced Drive Shaft - one piece
	U855Y	Thrust Plate & Drive Hub - Slipper
	U856Z	Repair Kit - New Slipper
	U858B	23mm Pro-Diff. - Team Spec.

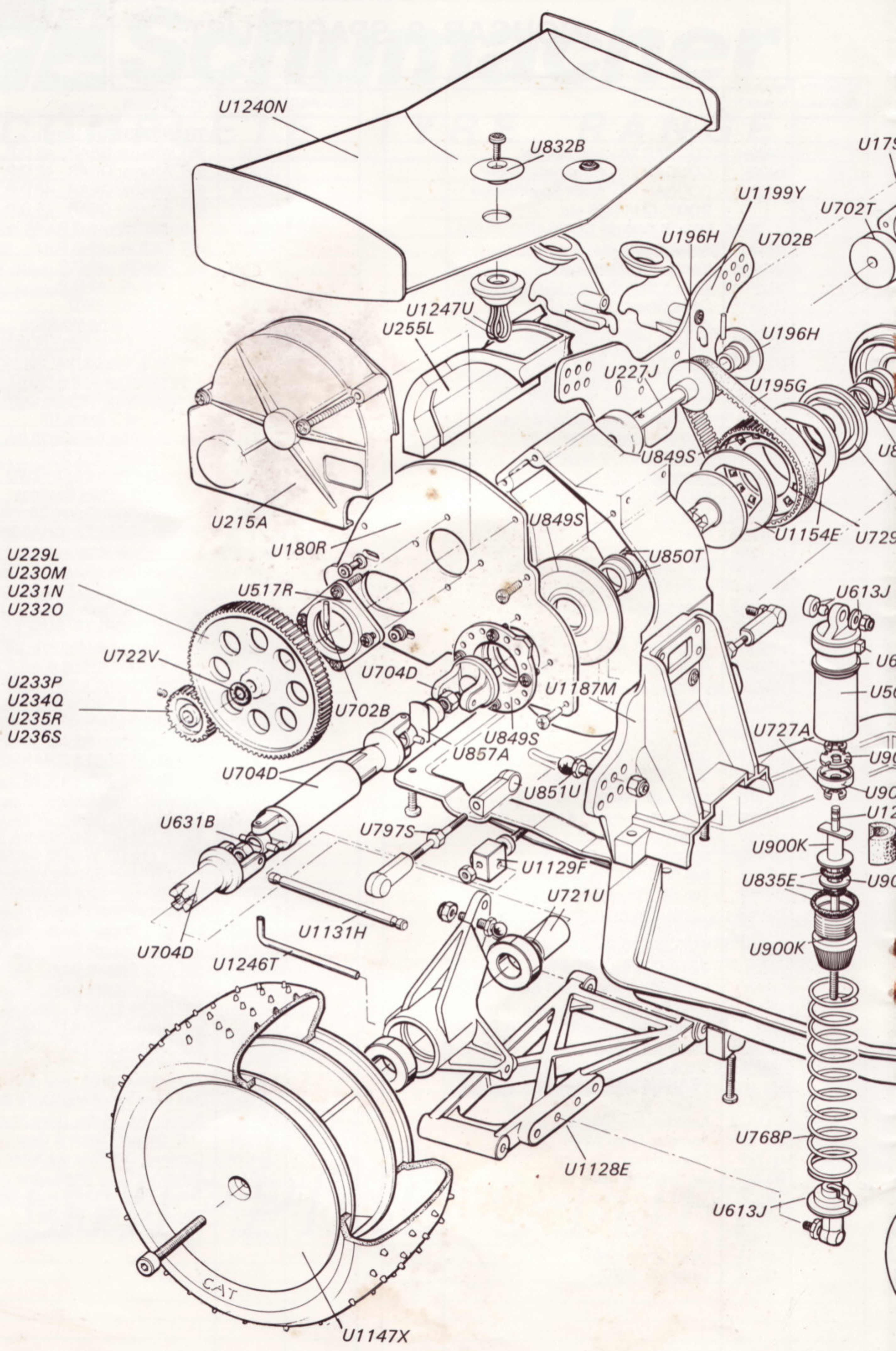

U1240N

U832B

U175

U1199Y

U702T

U196H

U702B

U1247U
U255L

U196H

U227J

U195G

U215A

U849S

U1154E

U729

U229L
U230M
U231N
U232O

U180R

U850T

U517R

U613J

U722V

U704D

U1187M

U233P
U234Q
U235R
U236S

U702B

U849S
U857A

U727A

U704D

U851U

U631B

U797S

U1129F

U900K

U704D

U1131H

U721U

U835E

U1246T

U900K

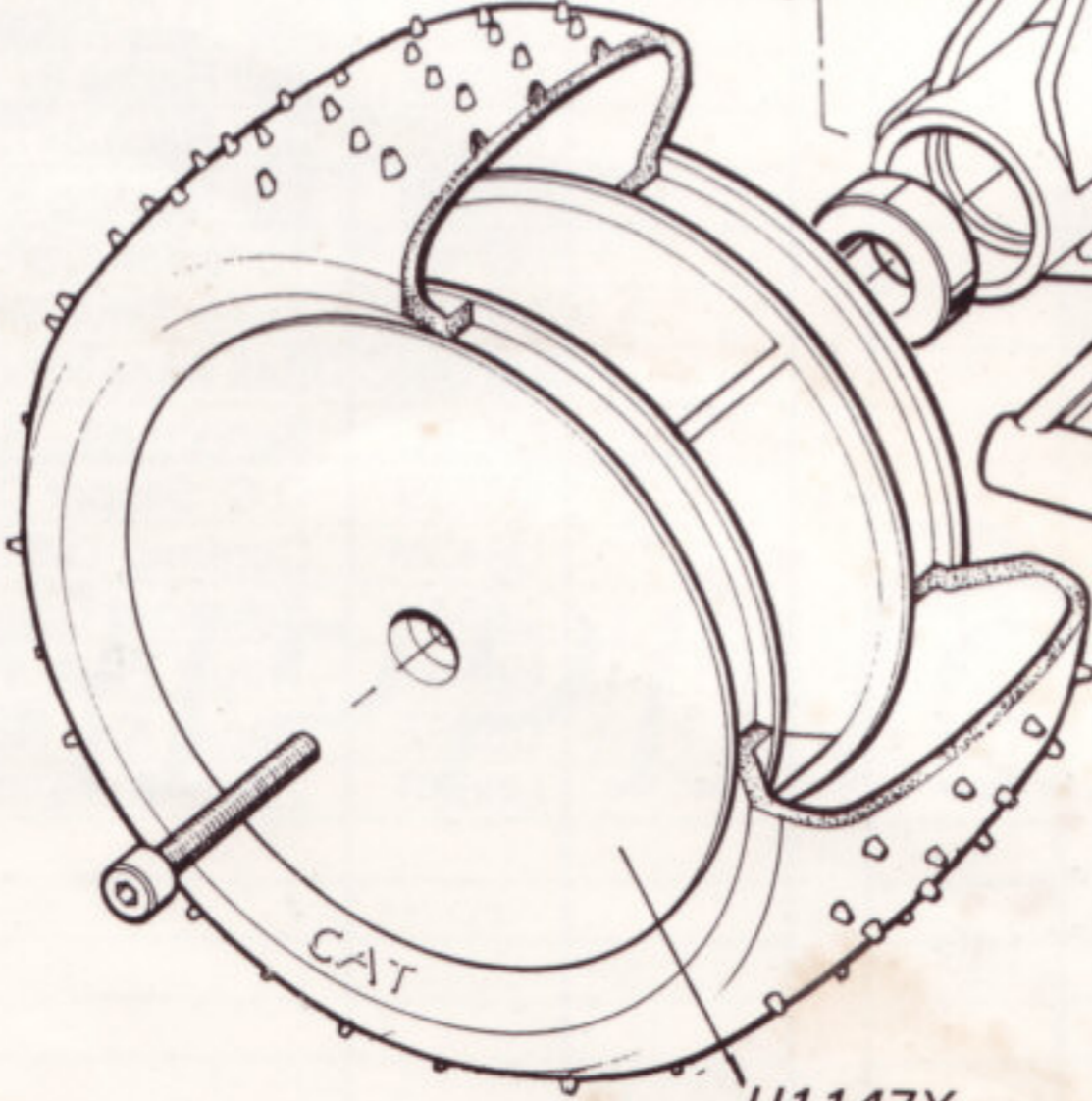

U1147X

U1128E

U768P

U613J

(DIAGRAM SHOWS SPORTS MODEL)

SPARES DIAGRAM

This diagram shows how to order your spares. Alternatives may be found in the spares list.

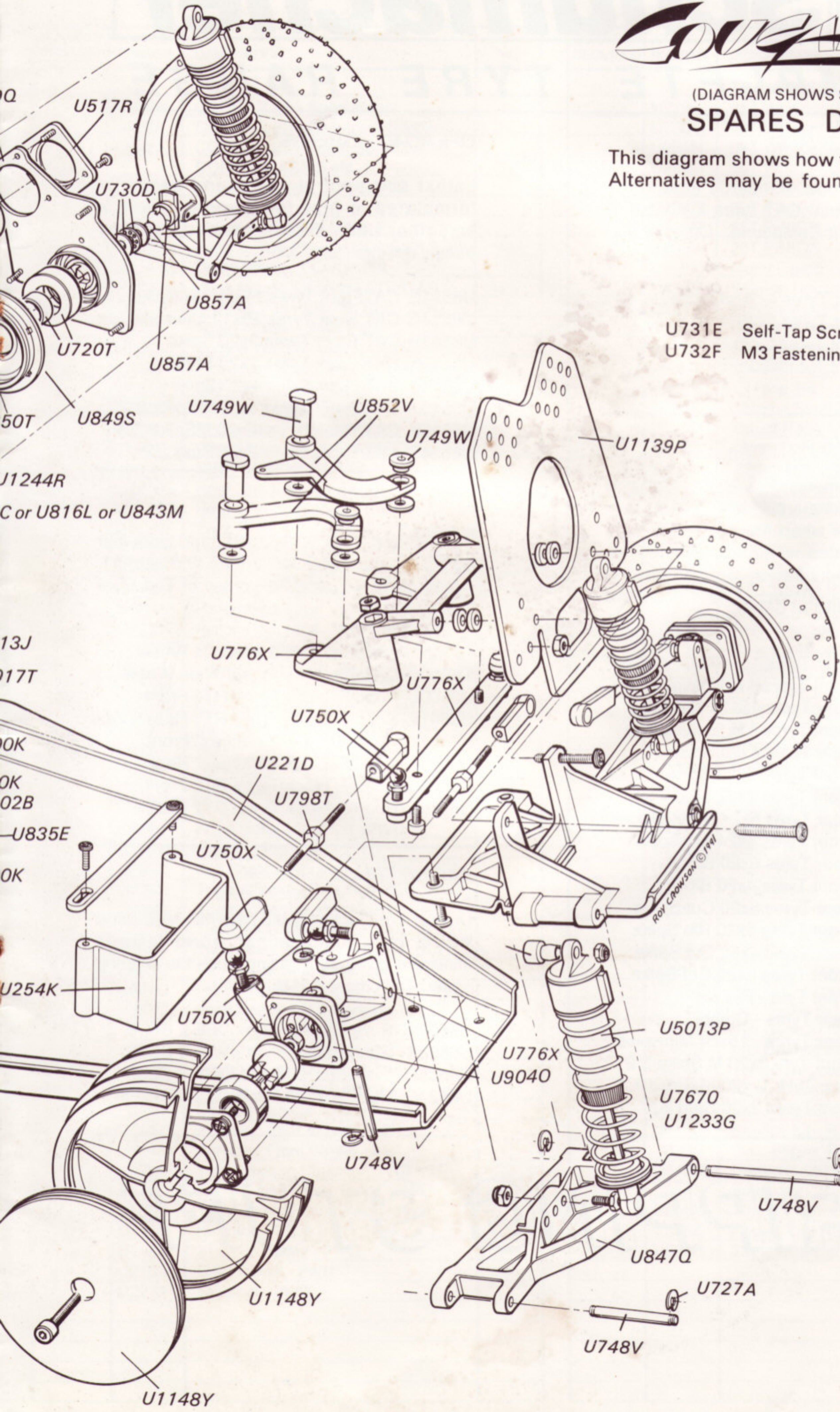

- U731E Self-Tap Screws - Spares Pack
- U732F M3 Fastenings - Spares Pack

Illustration Only
Details May Vary



COMPLETE TYRE RANGE

OFF ROAD "ORIGINALS"

These tyres set new standards around the World. The original CAT tyres available in Hard (Red) or Soft Compound. Often copied never bettered.

T650T CAT Rear Tyres 4x20 Soft Spike
T651U CAT Rear Tyres 4x20 Hard Spike
T652V CAT Front Tyres 3x20 Soft Spike
T653W CAT Front Tyres 3x20 Hard Spike

OFF ROAD - "BLUES"

Natural rubber compound gives very high grip in slippery conditions and is strong enough to give massive bite when the traction is high. Blues are very hard wearing! Minispikes - Use on hard slippery tracks. Spikes - Use on soft dirt and grass. Blocks - Use on hard dirt and tarmac.

T679W CAT Rear Tyres 15x12 Minispike
T681Y CAT Front Tyres 11x12 Minispike
T683A CAT Rear Tyres 15x15 Minispike
T685C CAT Front Tyres 11x15 Minispike
T687E CAT Rear Tyres 4x20 Spike
T688F CAT Front Tyres 3x20 Spike
T689G CAT Front Tyres 2x20 Stud
T690H CAT Rear Tyres 5x24 Minispike
T691I CAT Front Tyres 4x24 Minispike
T692J CAT Rear Tyres 6x20 Block
T693K CAT Front Tyres 4x20 Block
T694L CAT Rear Tyres 6x20 Cut Spike
T695M CAT Front Tyres 1x20 Rib Spike
T696N CAT Rear Tyres 4x20 Cut Spike
T697O CAT Front Tyres 3x20 Cut Spike
T698P CAT Front Tyre - Rib
U6506A CAT Rear Tyres - Combi
U6507B CAT Rear Tyres - 15x24 Minispike
U6517L CAT Front Tyre 8x20 M.Spike 2.2"
U6518M CAT Rear Tyre 12x20 M.Spike 2.2"
U6523R CAT Front Tyres 2x20 Stud 2.2"

OFF ROAD - "GREENS"

Latest soft natural compound specially formulated to give improved grip and a smoother ride. Recommended for hard bumpy dirt circuits.

U6511F CAT Front Tyres 11x12 Minispike
U6512G CAT Rear Tyres 15x12 Minispike
U6513H CAT Front Tyres 3x20 Spike
U6519N CAT Front Tyres 2x20 Stud
U6514 I CAT Rear Tyres 4x20 Spike
U6515J CAT Front Tyres 8x20 MSpike 2.2"
U6516K CAT Rear Tyres 12x20 MSpike 2.2"
U6524S CAT Front Tyres 2x20 Stud 2.2"

ROAD & TRACK

Super realistic low profile road tread tyres and high grip "Sponges" for tarmac and asphalt. Try the RT2 on your Rallycross or Dirt Oval Car.

T670N CAT Front "Sponges" On Wheel
T671O CAT Rear "Sponges" Wide Wheel
U6500U Road & Track Tyre - RT1 Front
U6501V Road & Track Tyre - RT1 Rear
U6504Y Road & Track "Sponges" Front
U6505Z Road & Track "Sponges" Rear
U6509D Road & Track Tyre - RT2 Front
U6510E Road & Track Tyre - RT2 Rear

RACING TRUCK

Unique high traction tread patterns, VEE2 and VEE4, plus Schumacher world famous minispike gives your racing truck the winning edge. To fit most 2.2" truck rims.

U6502W Truck Racing Tyre - VEE 2 BLUE
U6503X Truck Racing Tyre - VEE 4 BLUE
U6508C Truck 20x15 Minispike 2.2" BLUE
U6520O Truck 20x15 M.Spike 2.2" GREEN

GRIPPING STUFF

FRONT SUSPENSION

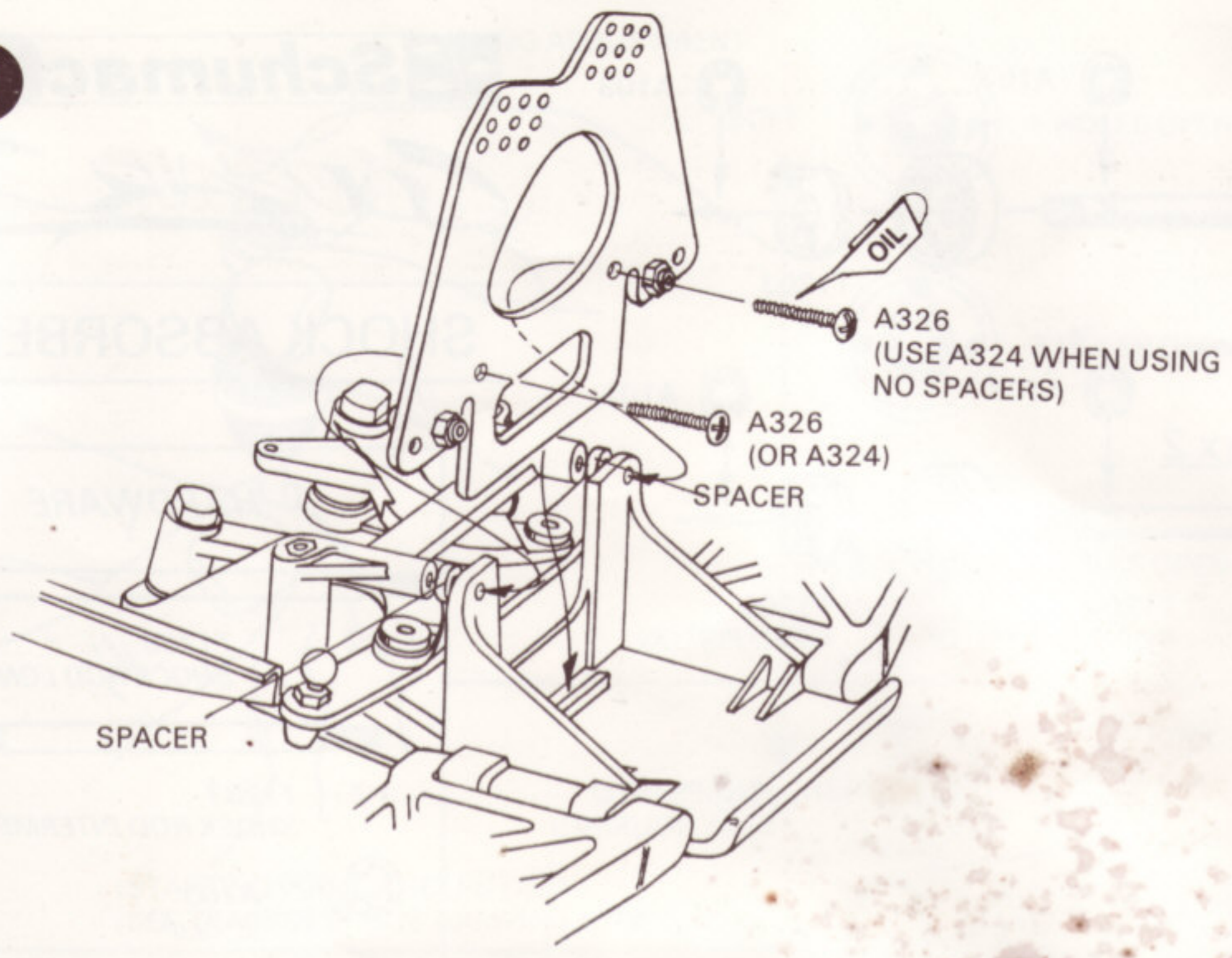

RAKE ANGLE ADJUSTMENT

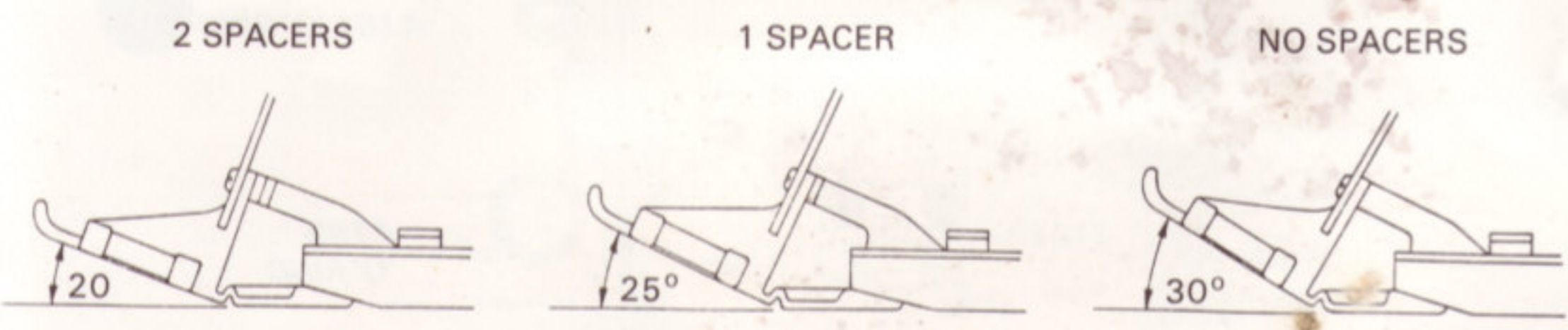

HARDWARE

 A326 No.4 x 3/4"
SELFTAP PANHEAD
x 2

 A095 45mm
TURNBUCKLE
x 4

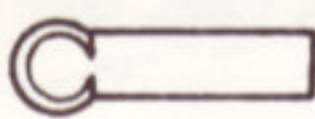
 T320
BALL SOCKET
x 8

 SPACER
(ON MOULDING
WITH T328
STEERING BLOCK)

 A324
No.4 x 1/2"
SELFTAP PANHEAD
x 2

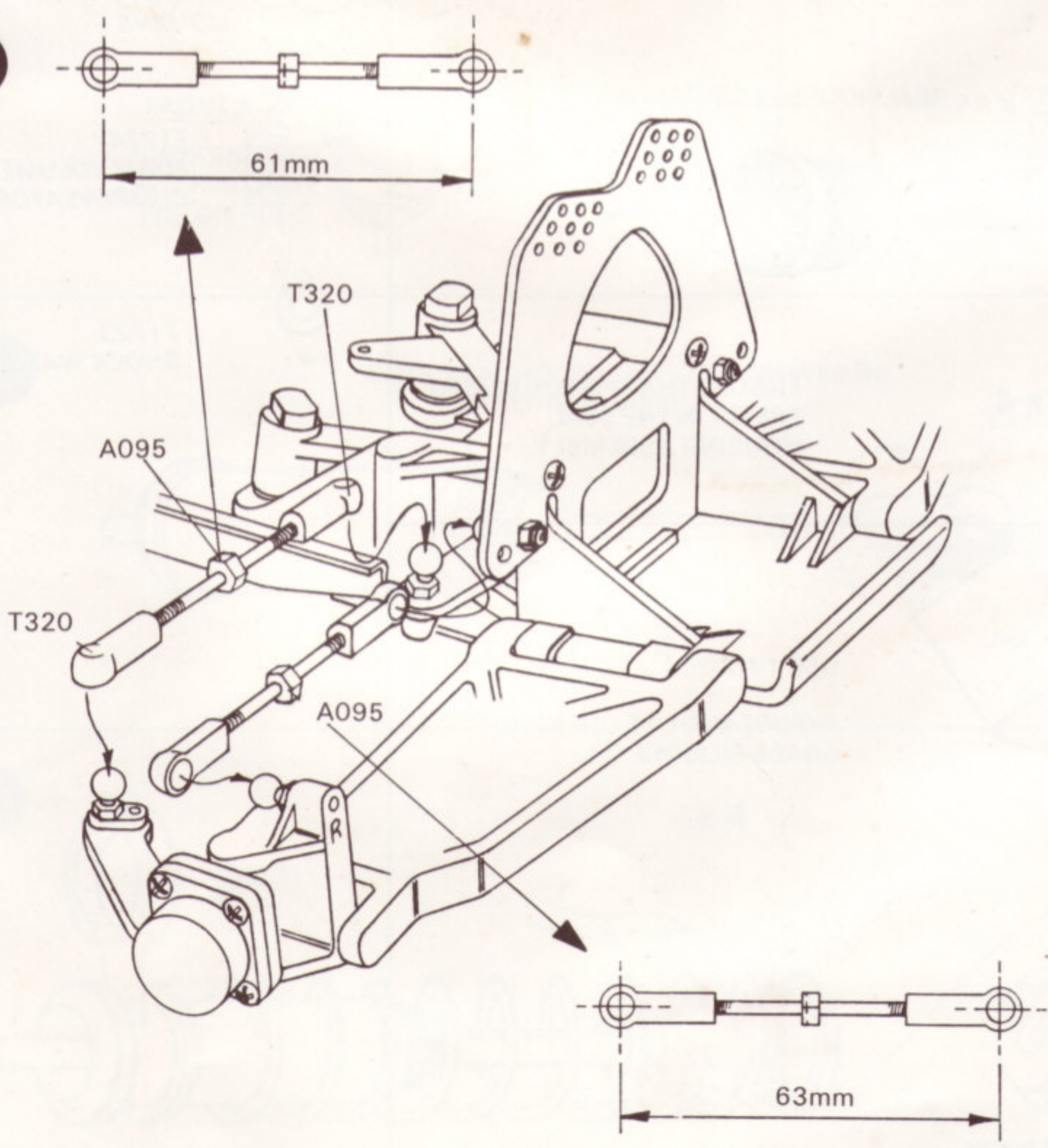

SHOCK ABSORBERS

1

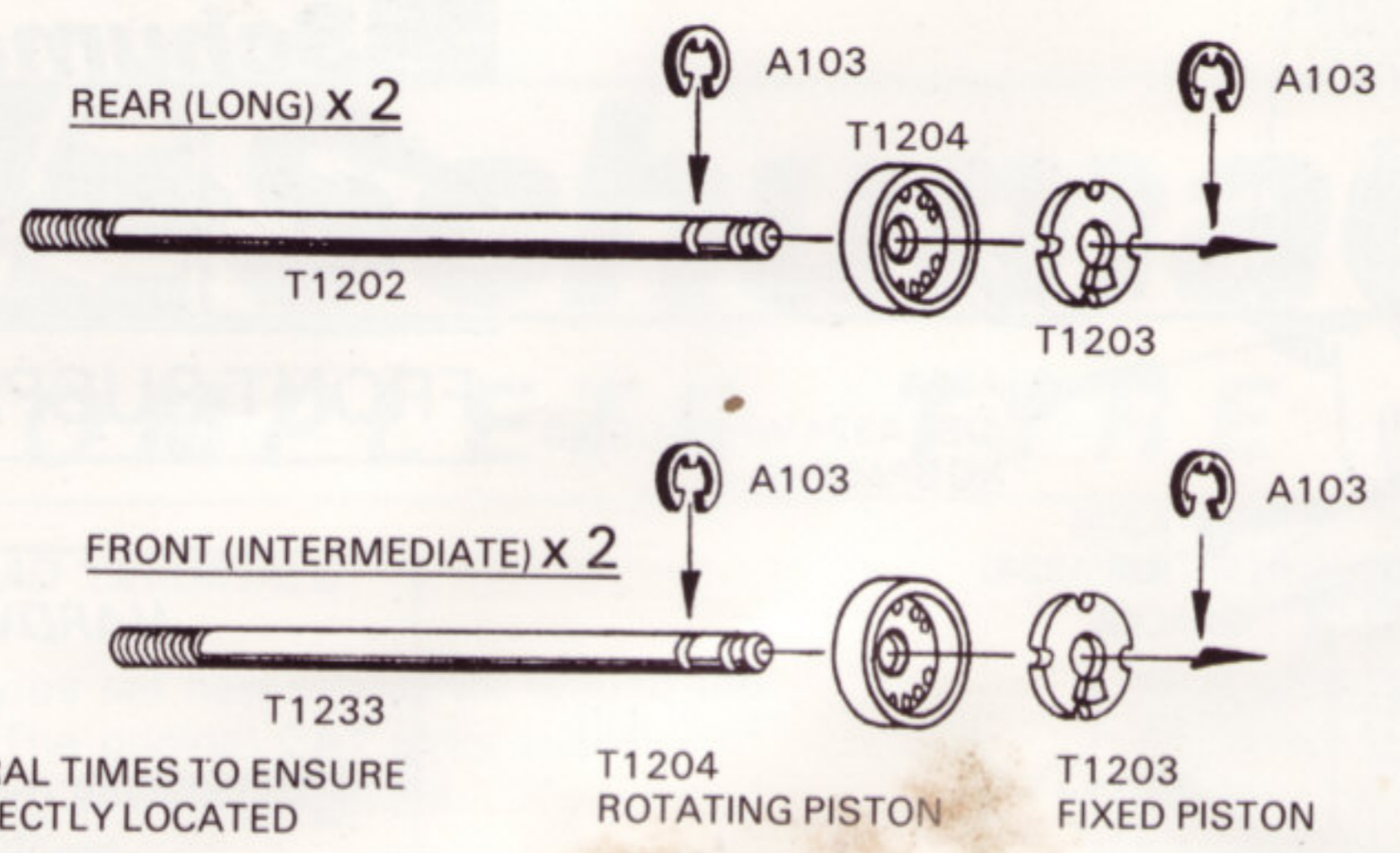

ROTATE SEVERAL TIMES TO ENSURE 'E' CLIPS CORRECTLY LOCATED

2

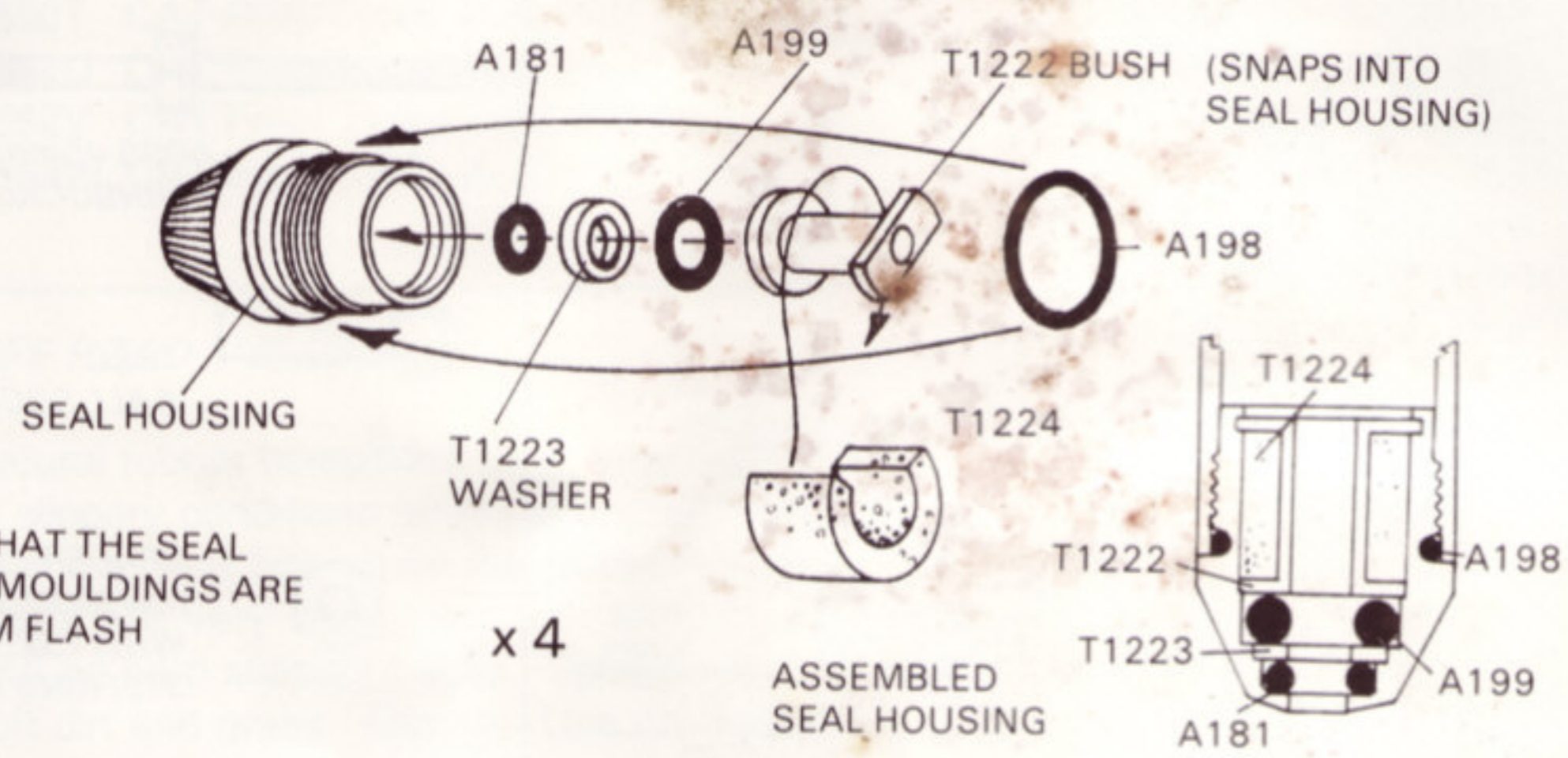

ENSURE THAT THE SEAL HOUSING MOULDINGS ARE FREE FROM FLASH



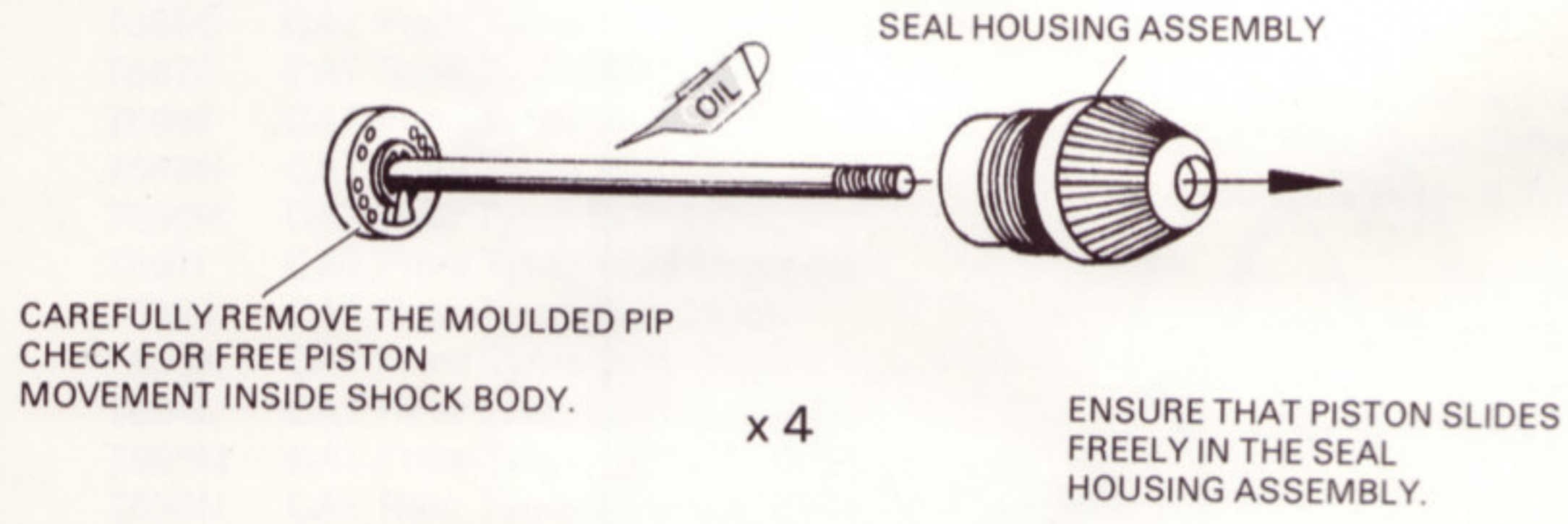



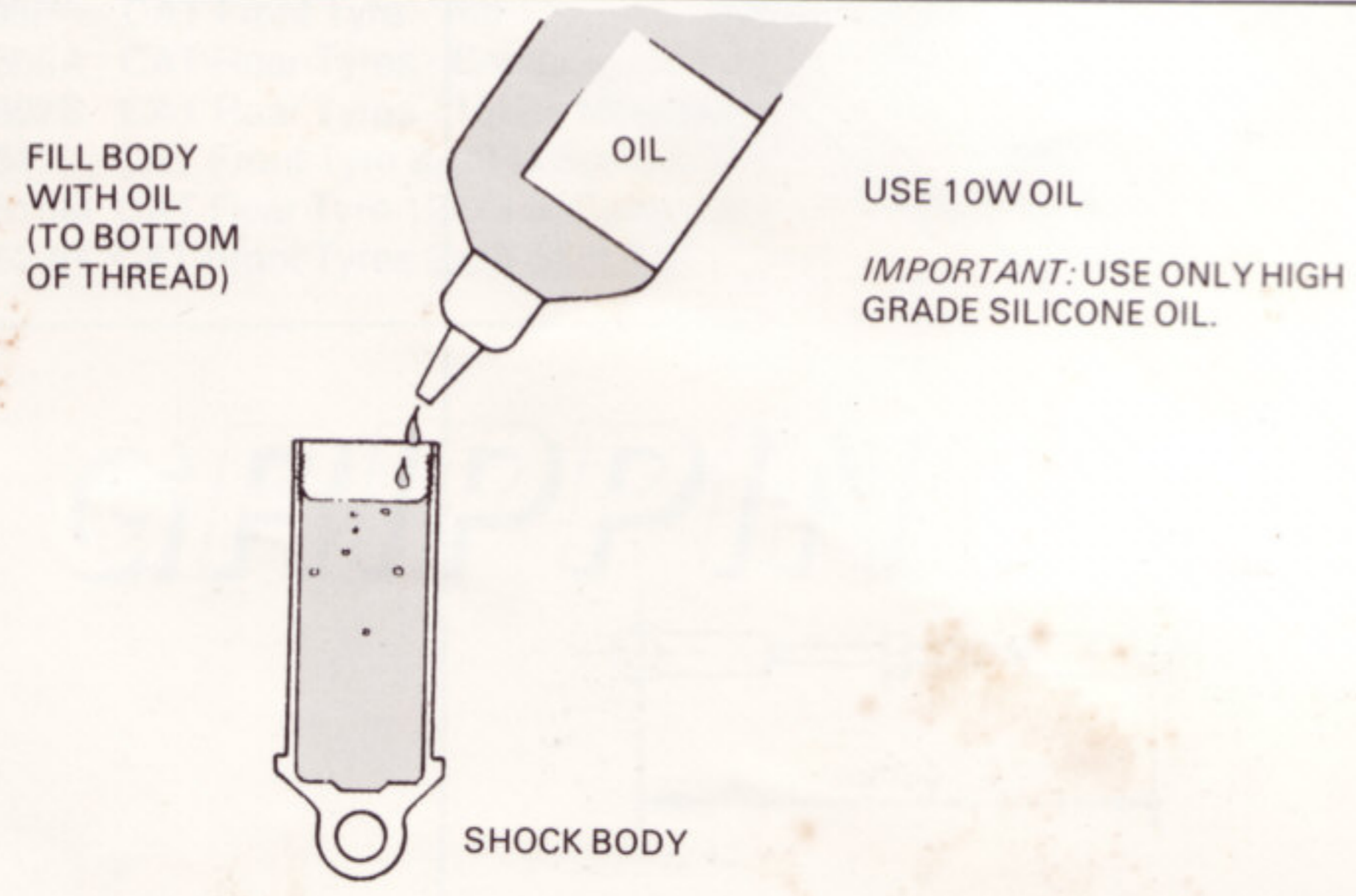

3

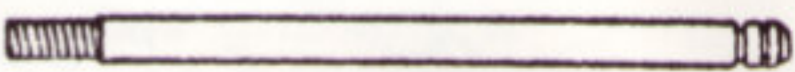

4



HARDWARE

-  x 2 T1233 SHOCK ROD LONG
-  x 2 T1233 SHOCK ROD INTERMEDIATE
-  x 4 A103 'E' CLIP
-  x 4 A181 'O' RING
-  x 4 A199 'O' RING
-  x 4 A198 'O' RING
-  x 4 T1224 FOAM VOLUME COMPENSATOR
-  x 4 T1223 SHOCK WASHER

5

DAMPING ADJUSTMENT

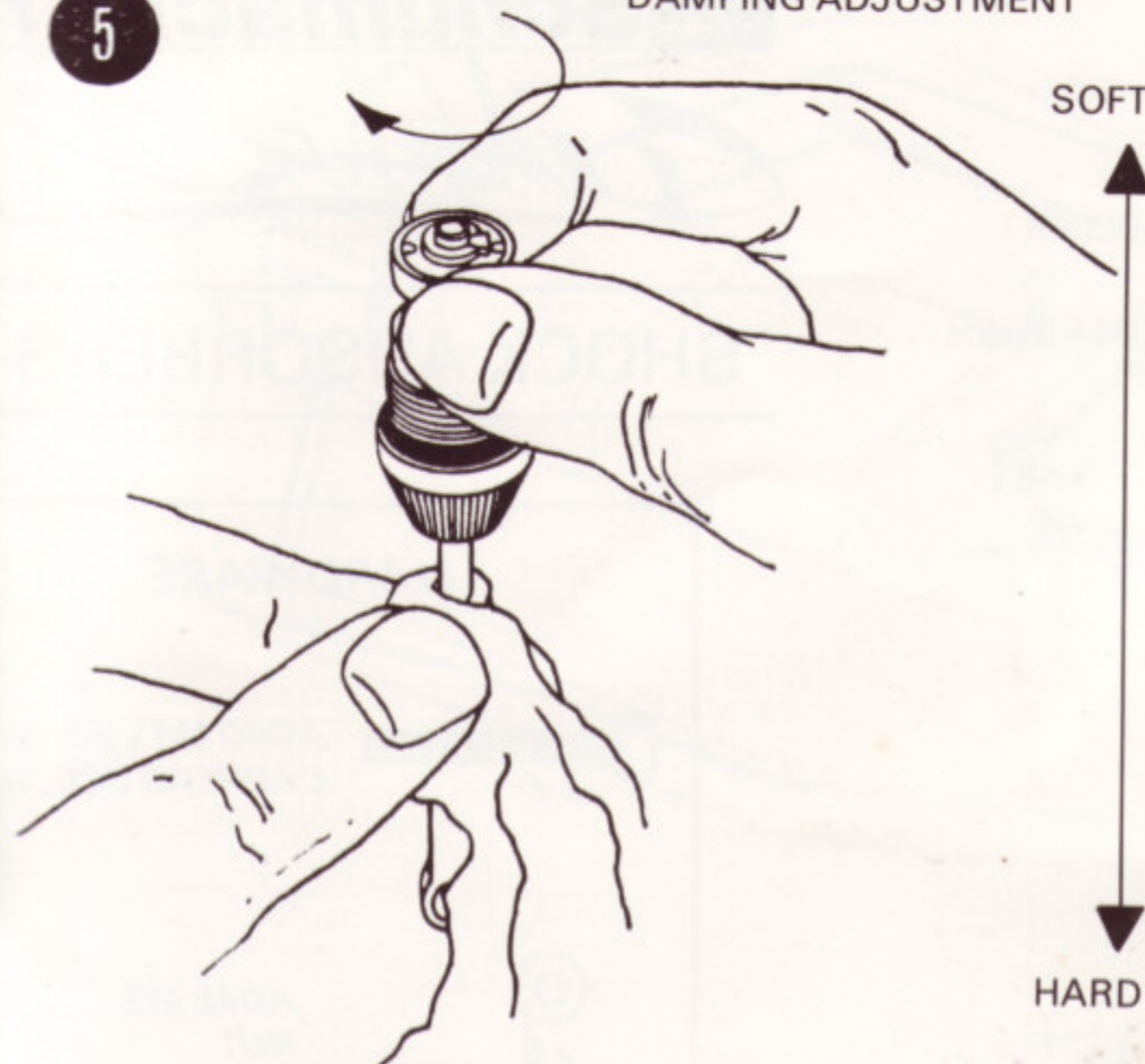

SOFT

HARD

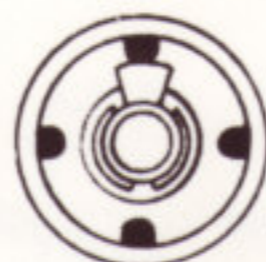

4 HOLES OPEN



3 HOLES OPEN



2 HOLES OPEN



1 HOLE OPEN

(STARTING POINT 2 HOLES OPEN)
(SEE TRACKSETTINGS DAMPING STEP 7)

SHOCK ABSORBERS

HARDWARE

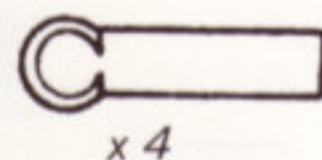

T320
BALL JOINT SOCKET

x 4

6

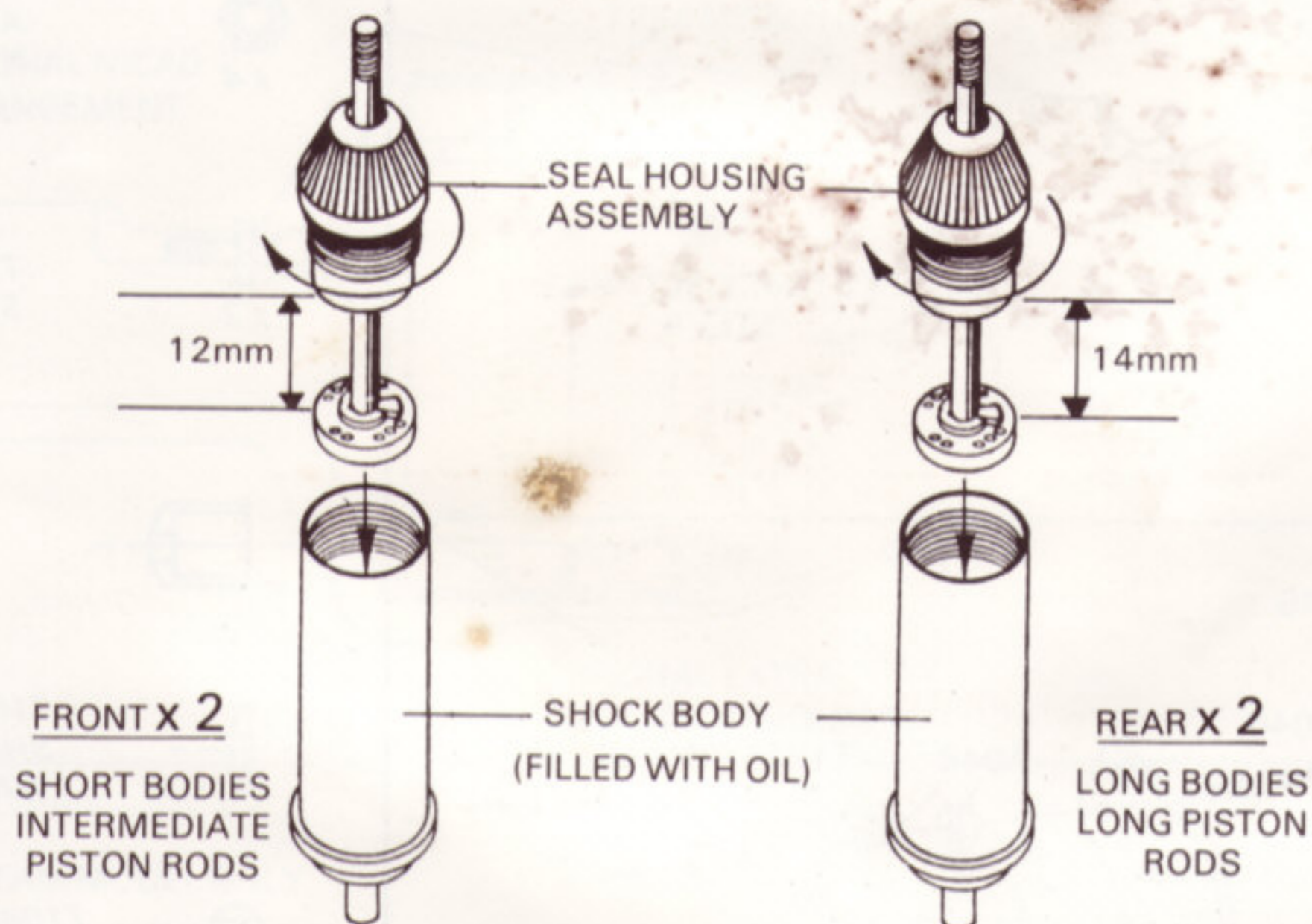

7

NOTE: SEAL HOUSING FULLY SCREWED IN
- NO 'O' RING VISIBLE.

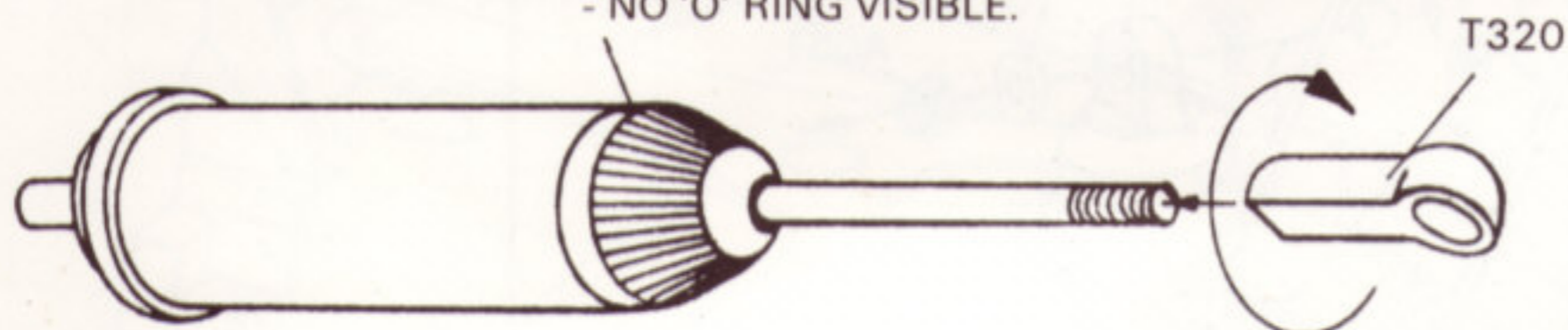

x 4

8

x 4

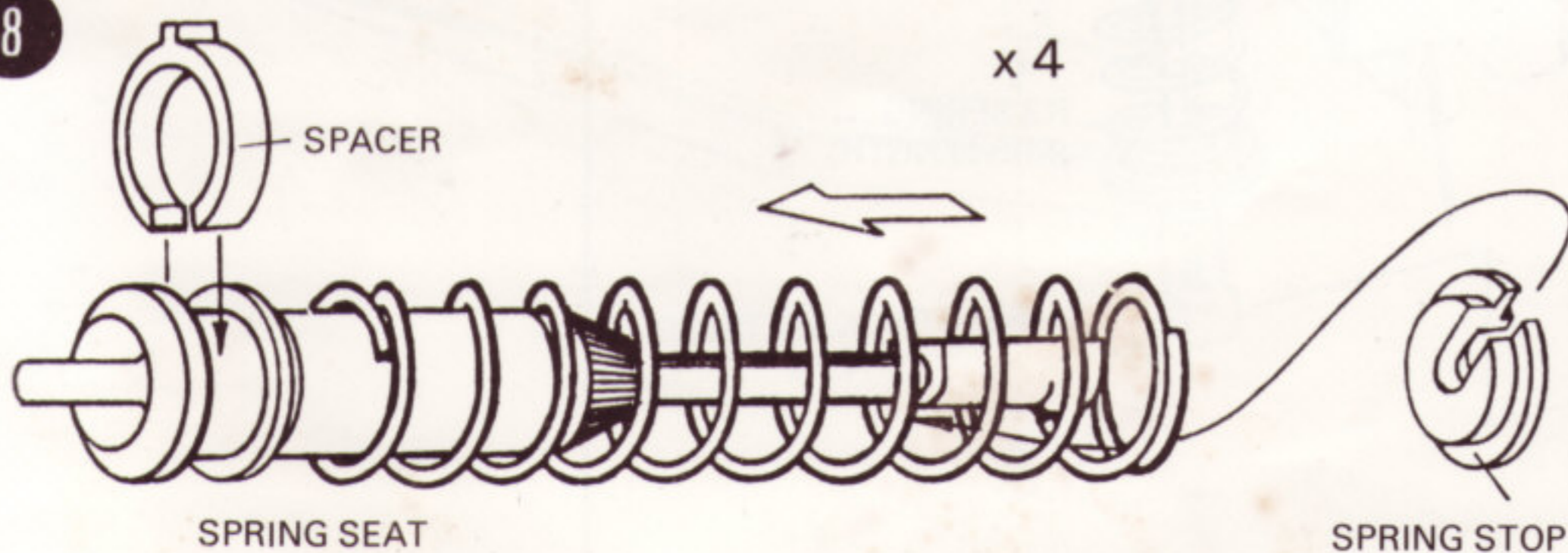

SPRING SEAT

SPRING STOP

SHOCK ABSORBERS

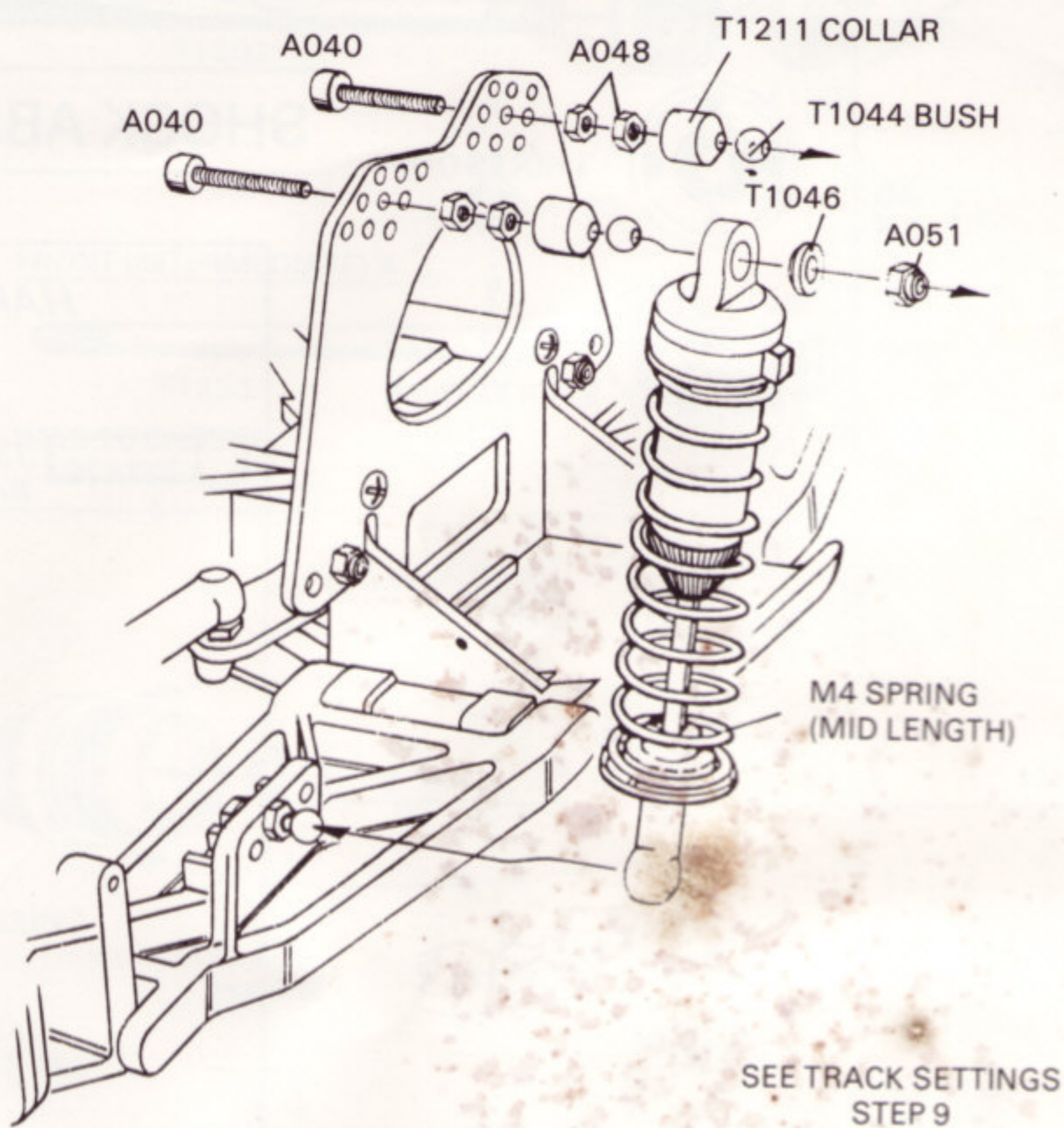



HARDWARE

 A040 M3 x 20mm
CAPHEAD SCREW
x 4

 A048 M3
NUT
x 8

 A051 M3
NYLOC NUT
x 4

 T321 BALL
STUD SHORT
x 2

 T1211
COLLAR

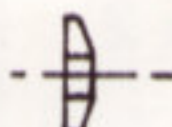
 T1046
SHOCK MOUNT
WASHER

 T1044
SPHERICAL BUSH

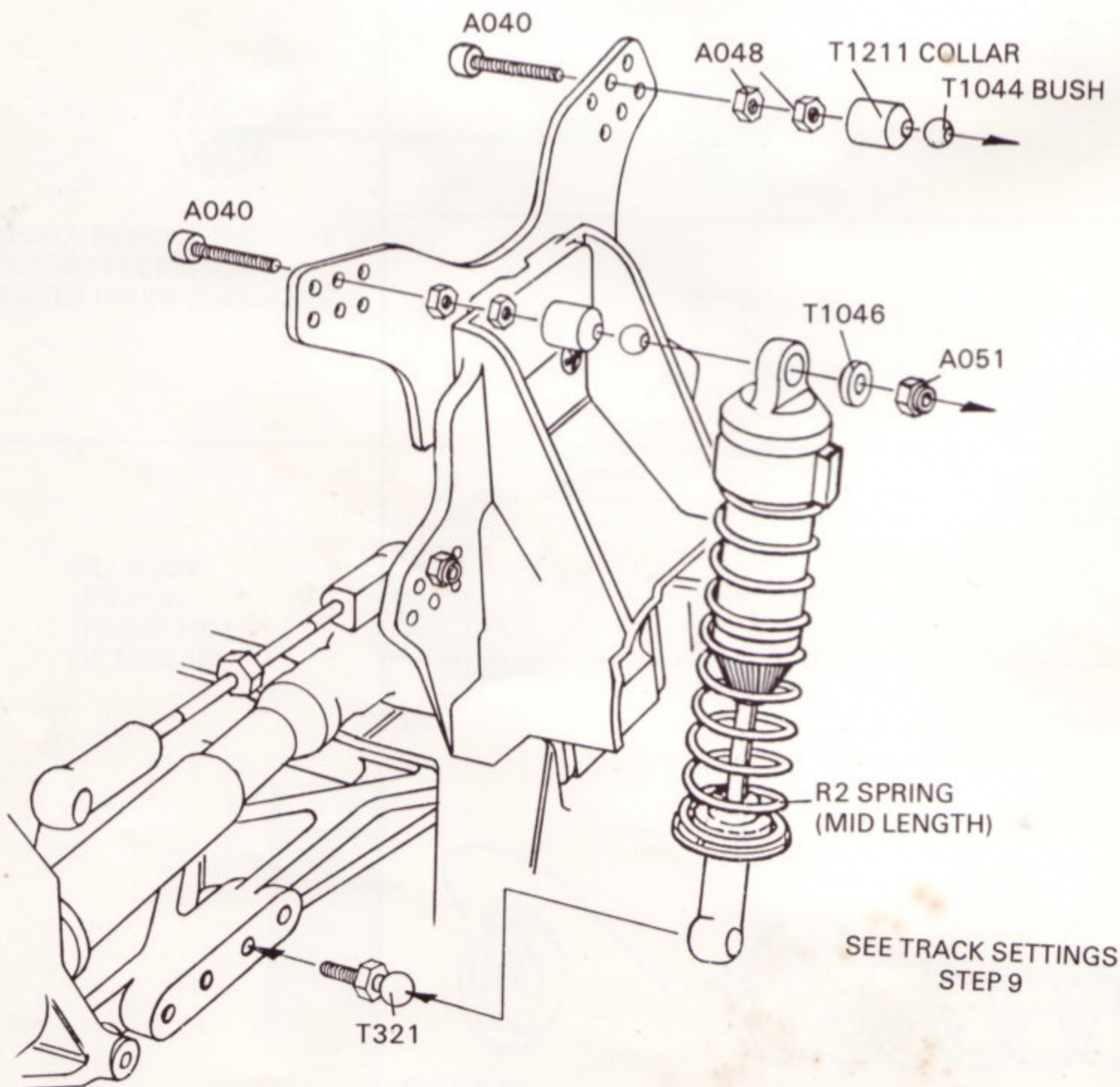

1

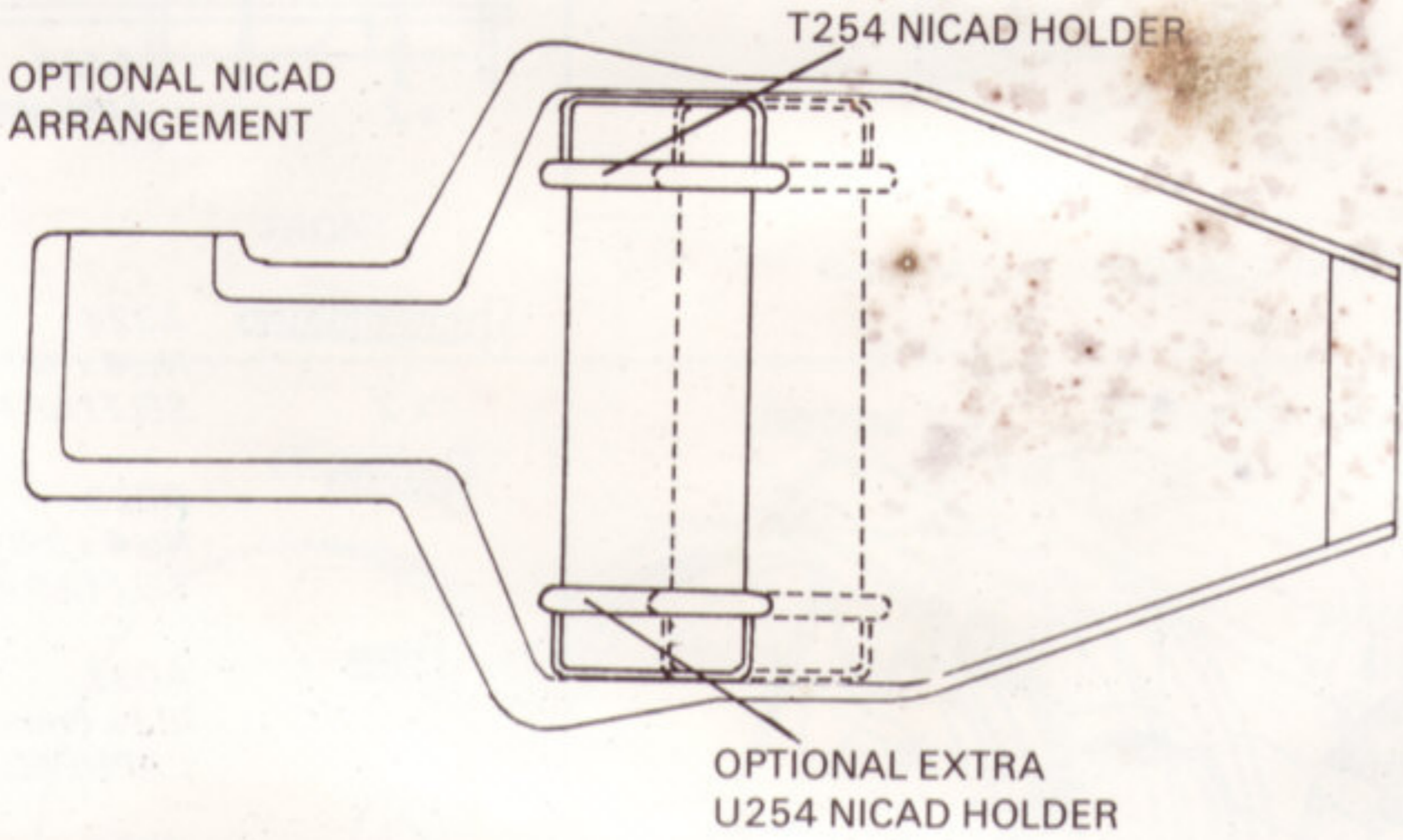
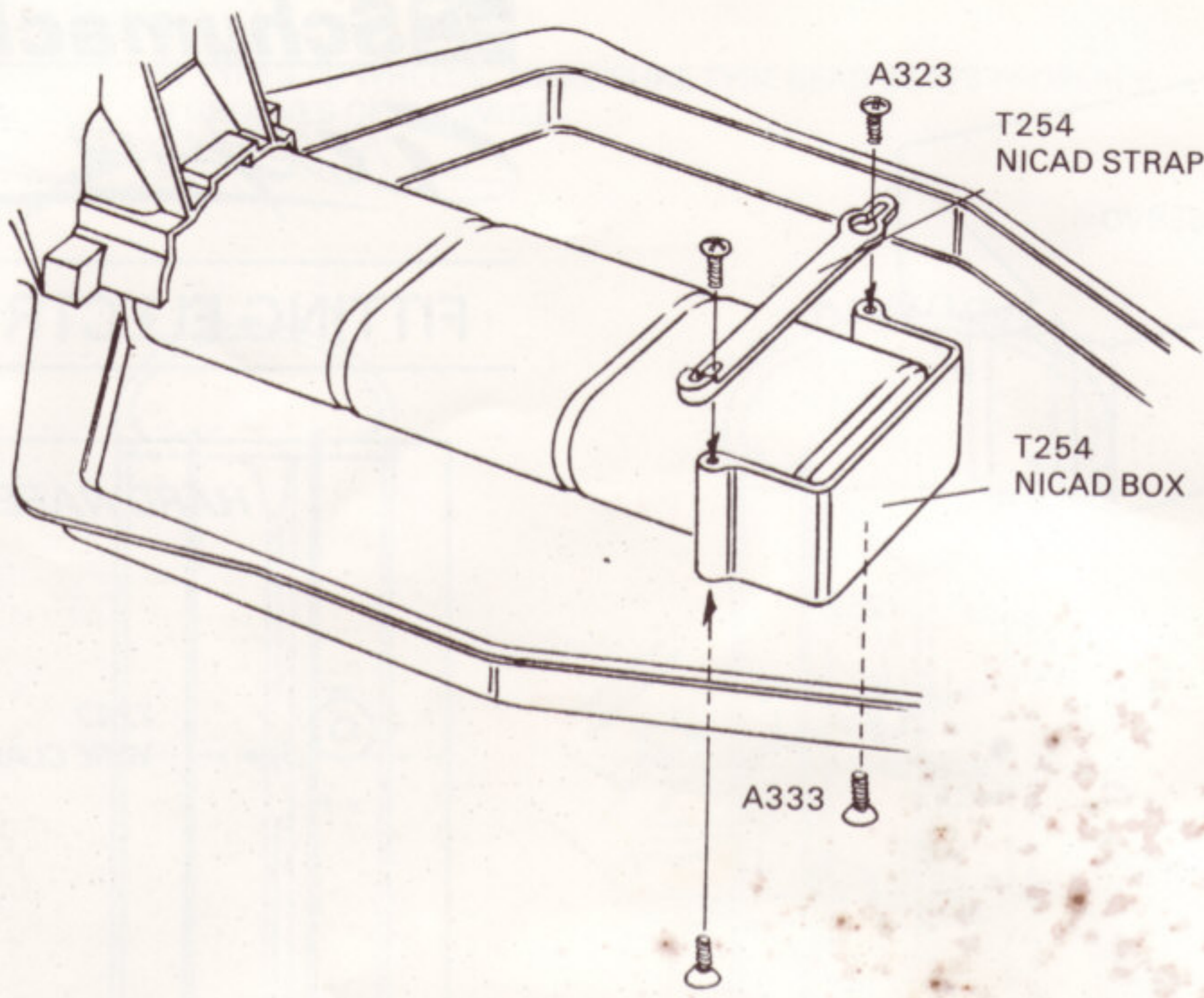

NICAD INSTALLATION

HARDWARE

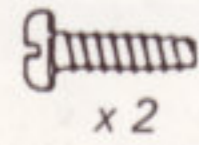

A323 No. 4 x 3/8"
SELFTAP SCREW

x 2



A333 No. 4 x 3/8"
COUNTERSUNK
SELFTAP SCREW

x 2

2

TEAM MODEL ONLY

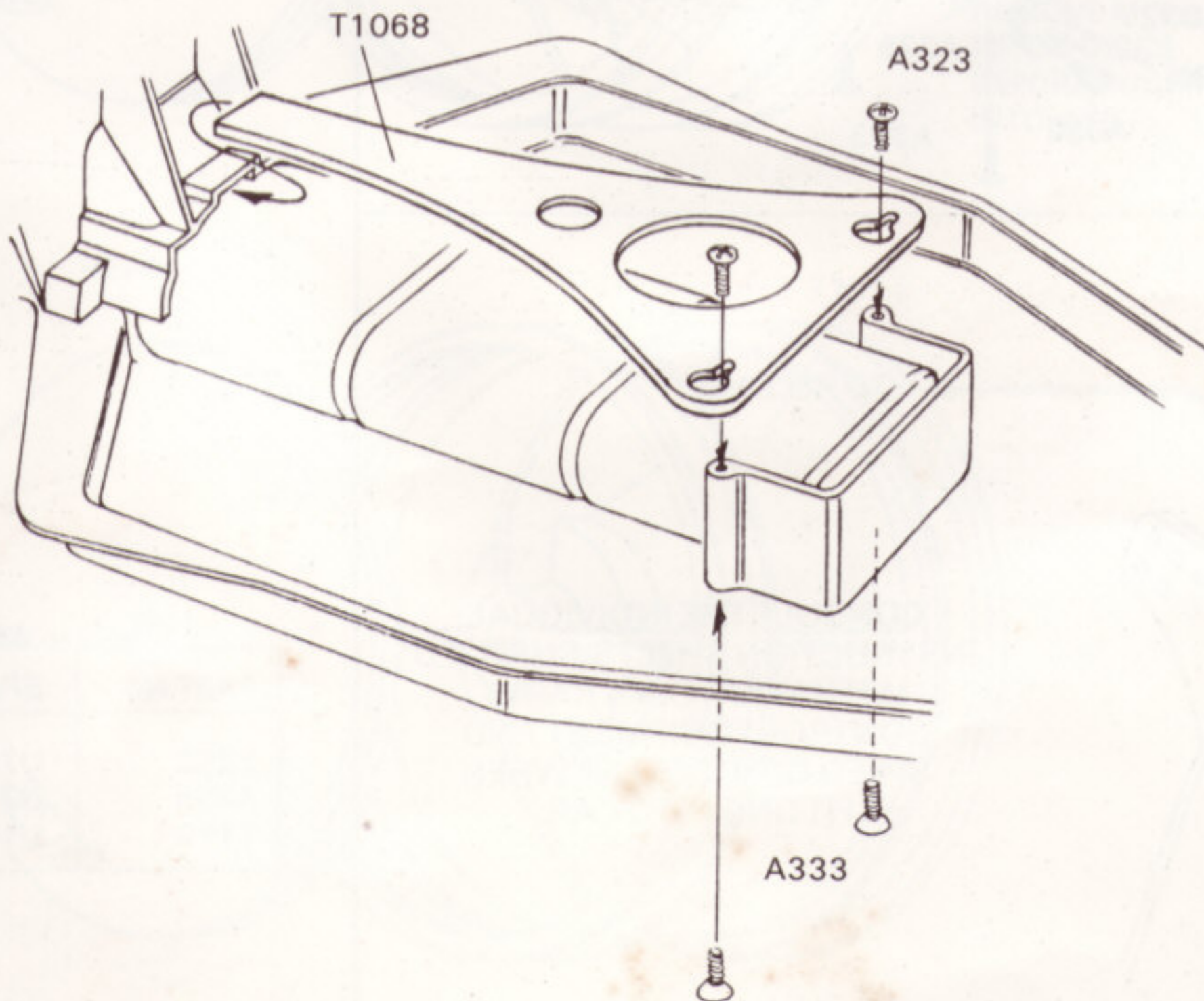

PART No.	SPARES No.
T254	U254K
T1068	U1068W

1

SERVO SAVER ASSEMBLY

FITTING ELECTRICS

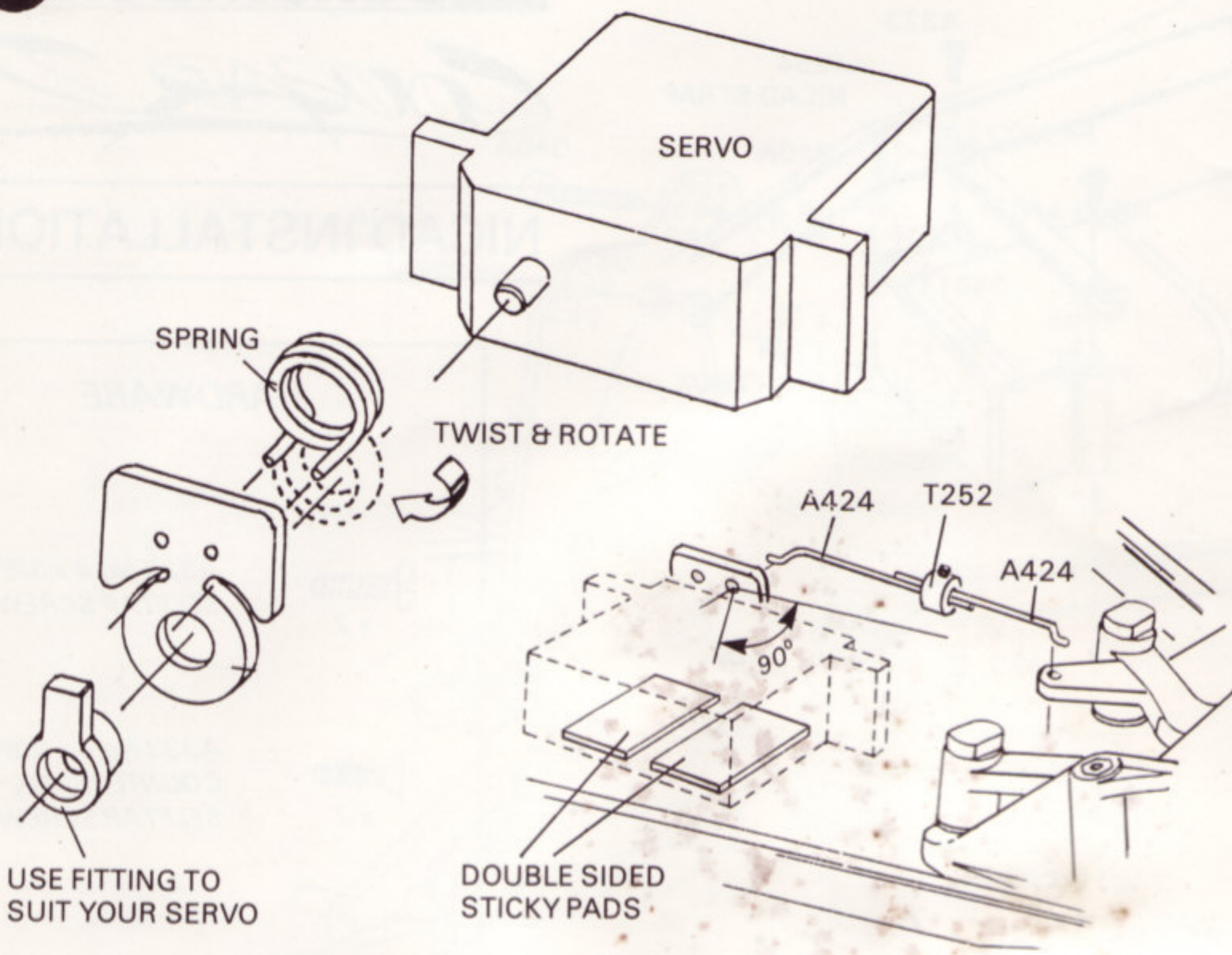

HARDWARE



T252
WIRE CLAMP

x 1

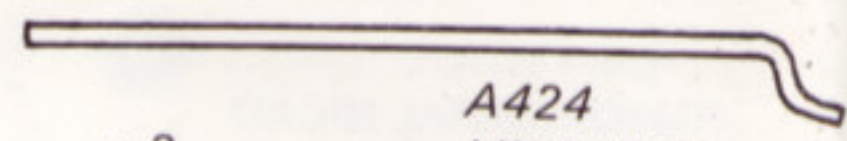

A424
LINK WIRE

x 2



A326
No.4 x 3/4"
SELFTAP PANHEAD

x 2

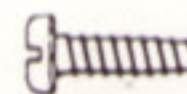

A323
No.4 x 3/8"
SELFTAP PANHEAD

x 2



A032
M3 x 6mm
CAPHEAD SCREW

x 2



A225
STEEL WASHER

x 2

2

MOTOR & MOTOR GUARD INSTALLATIONS

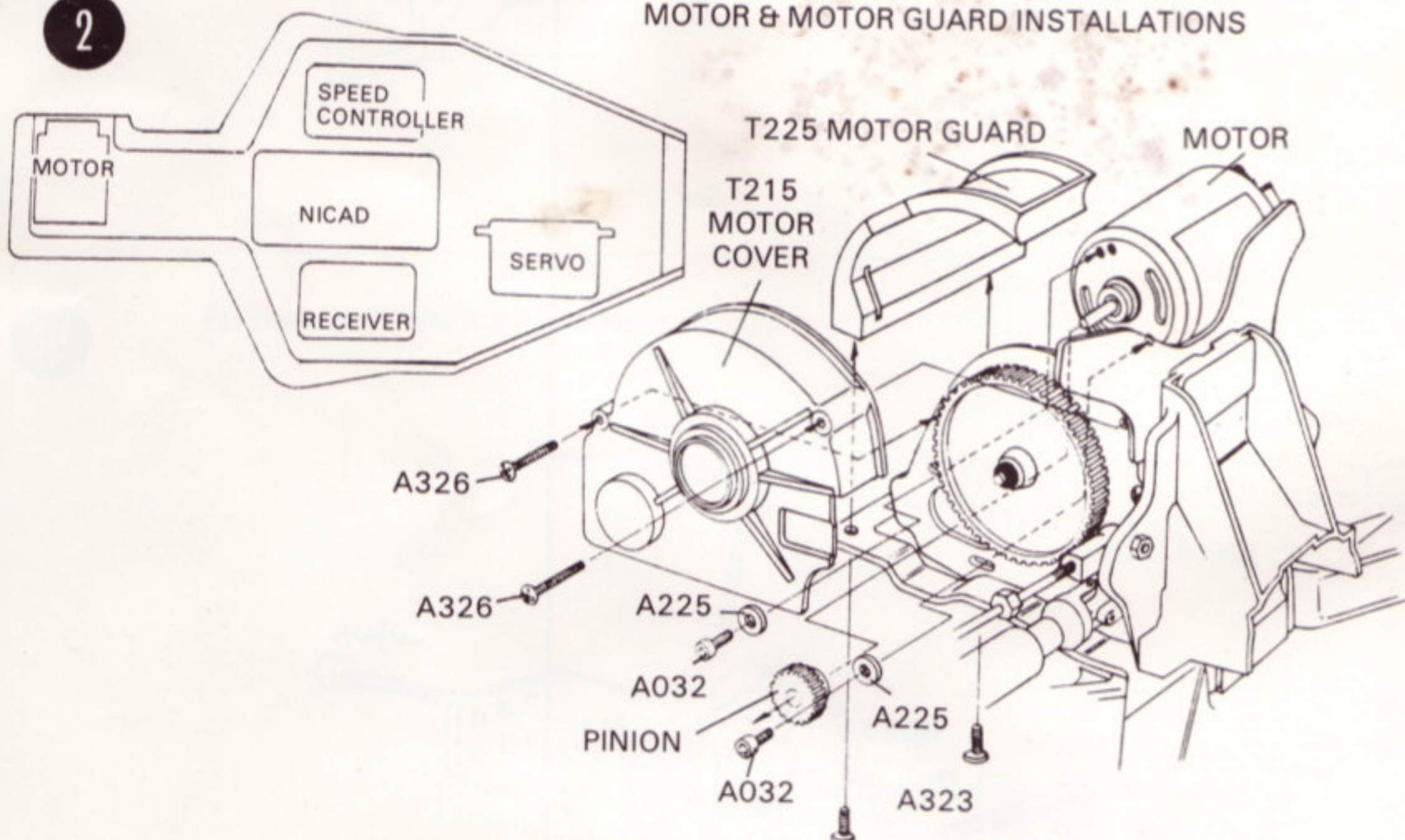

3

FITTING ARIEL

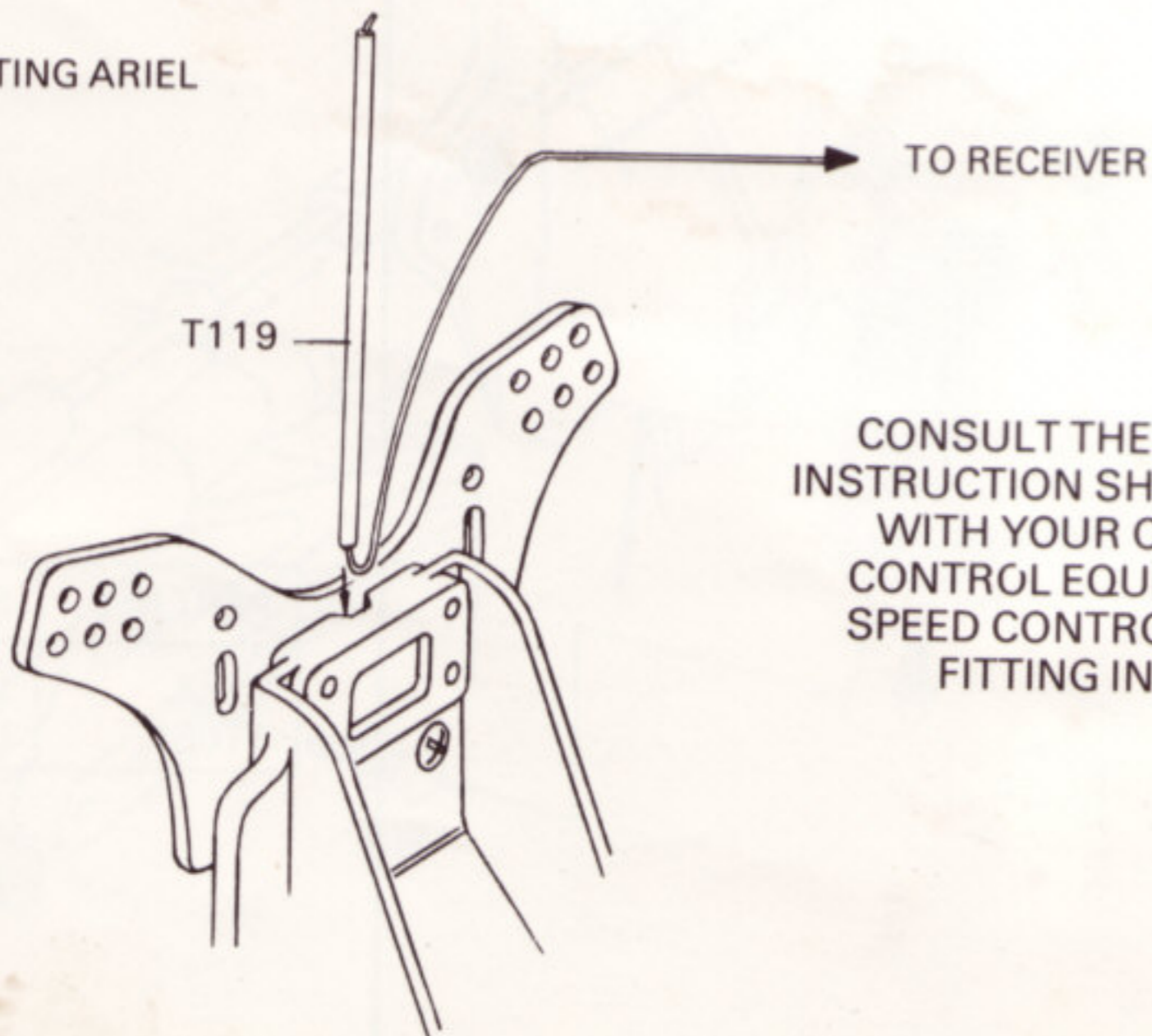

CONSULT THE INDIVIDUAL INSTRUCTION SHEETS SUPPLIED WITH YOUR OWN RADIO CONTROL EQUIPMENT AND SPEED CONTROLLER WHEN FITTING INTO CAR.

PART No.	SPARES No.
T252	U717Q
A424	U717Q
T119	U119J

1

FIT TYRES TO WHEELS. MAKE SURE TYRE BEAD SEATS PROPERLY IN GROOVES OF THE WHEEL.

WHEELS & TYRES

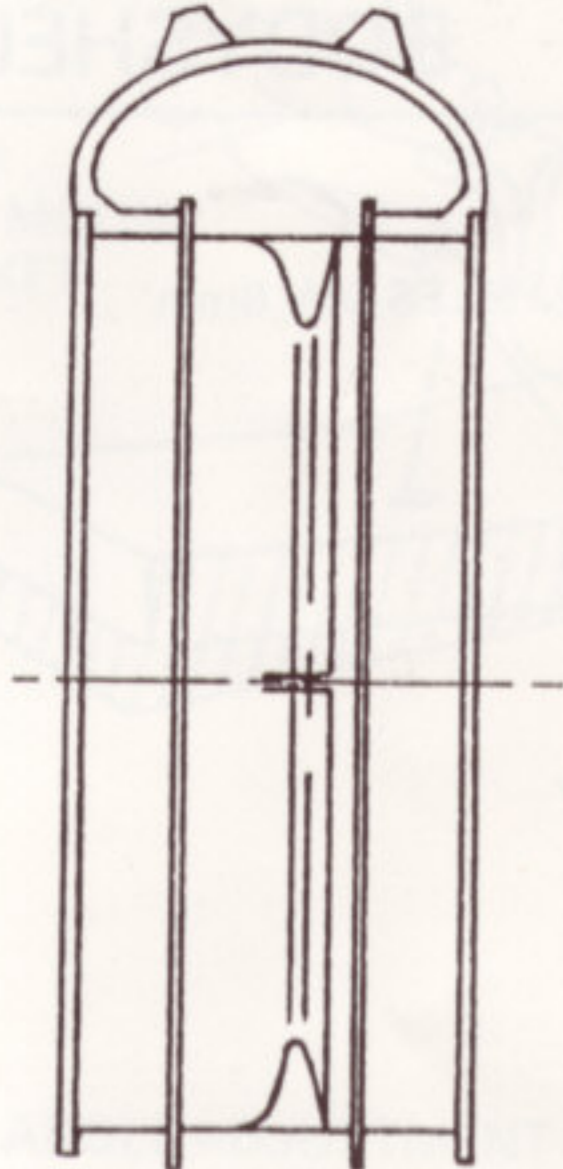

FRONT

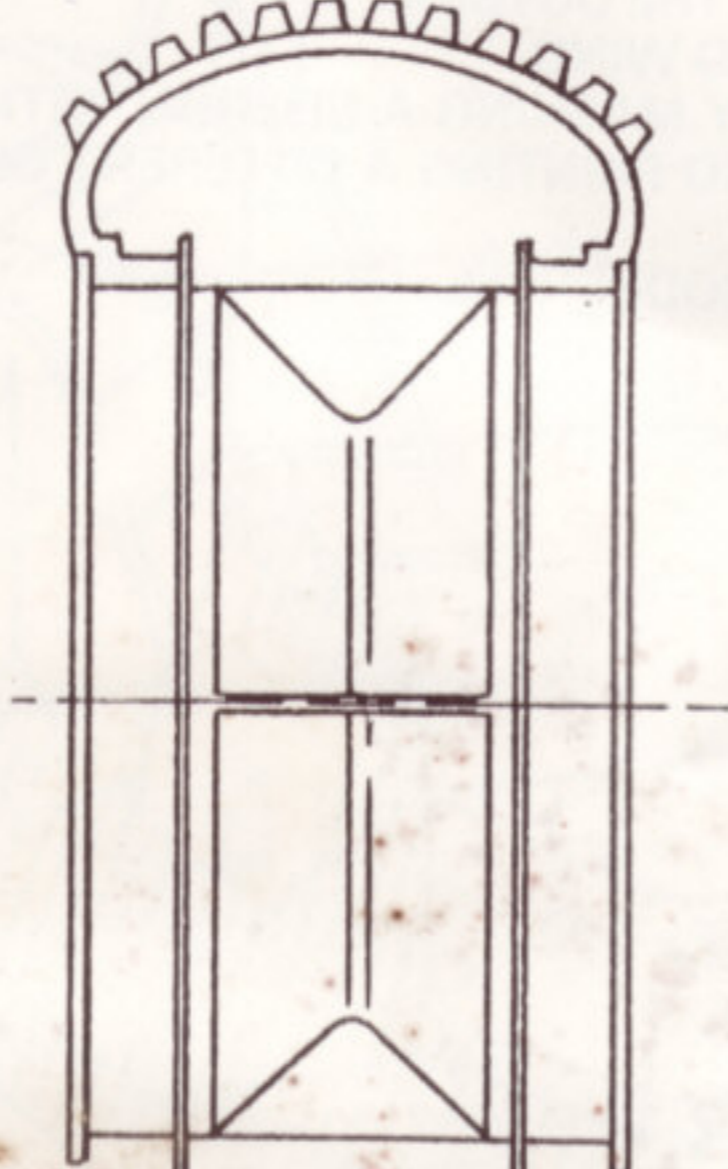

REAR

HARDWARE

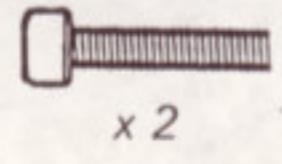

x 2

A038 M3 x 12mm
CAPHEAD SCREW

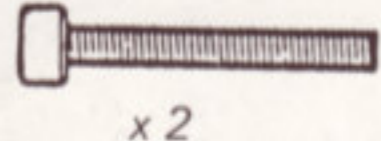

x 2

A040 M3 x 20mm
CAPHEAD SCREW

2

FRONT

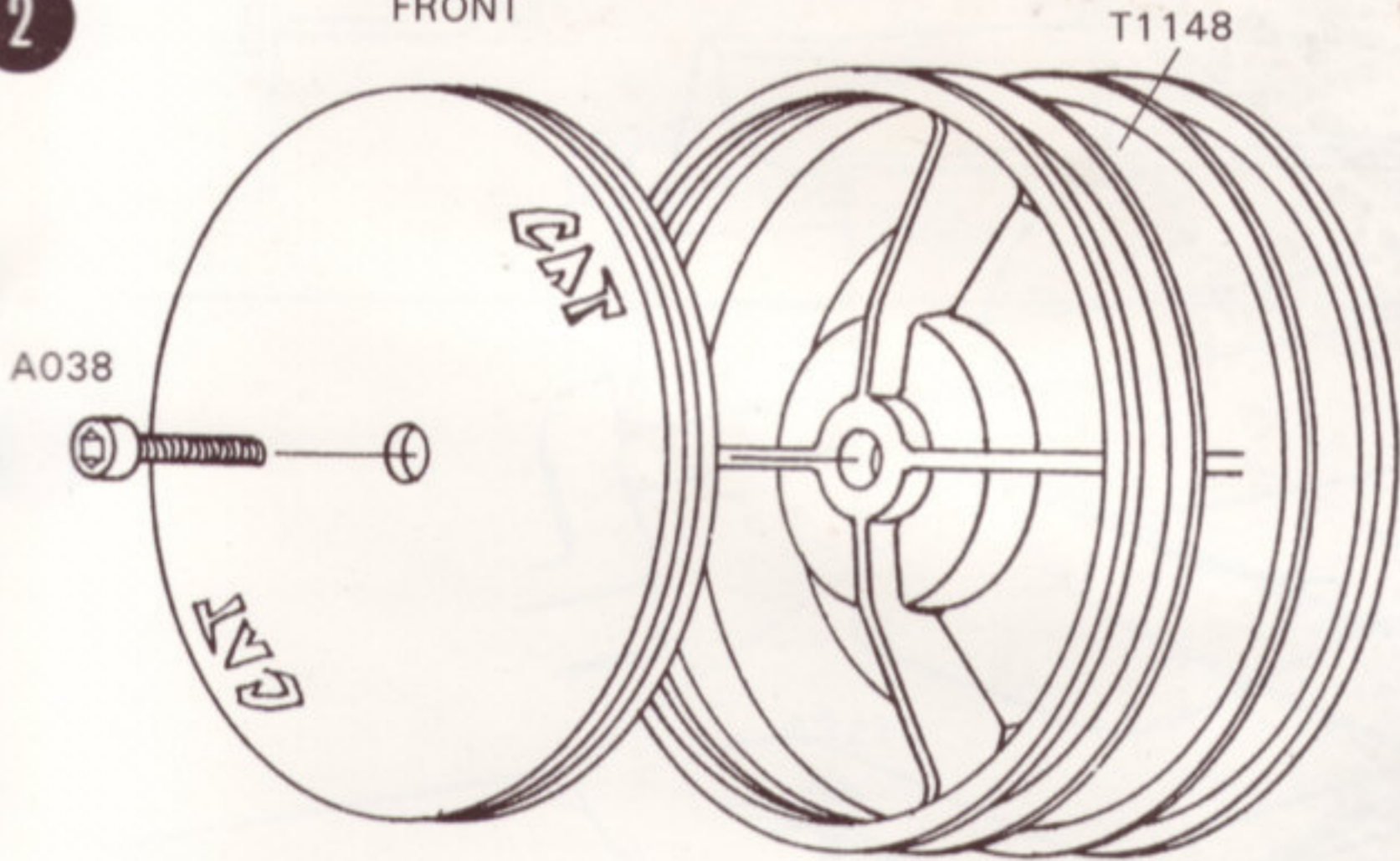

ENSURE WHEEL
ENGAGES WITH
DOGS IN INNER HUB
WHEN TIGHTENING
SCREW.

ENSURE FRONT
WHEELS
SPIN FREELY.

REMOVE MOULDED
PIP ON DISCS
BEFORE PUSHING
INTO WHEEL

REAR

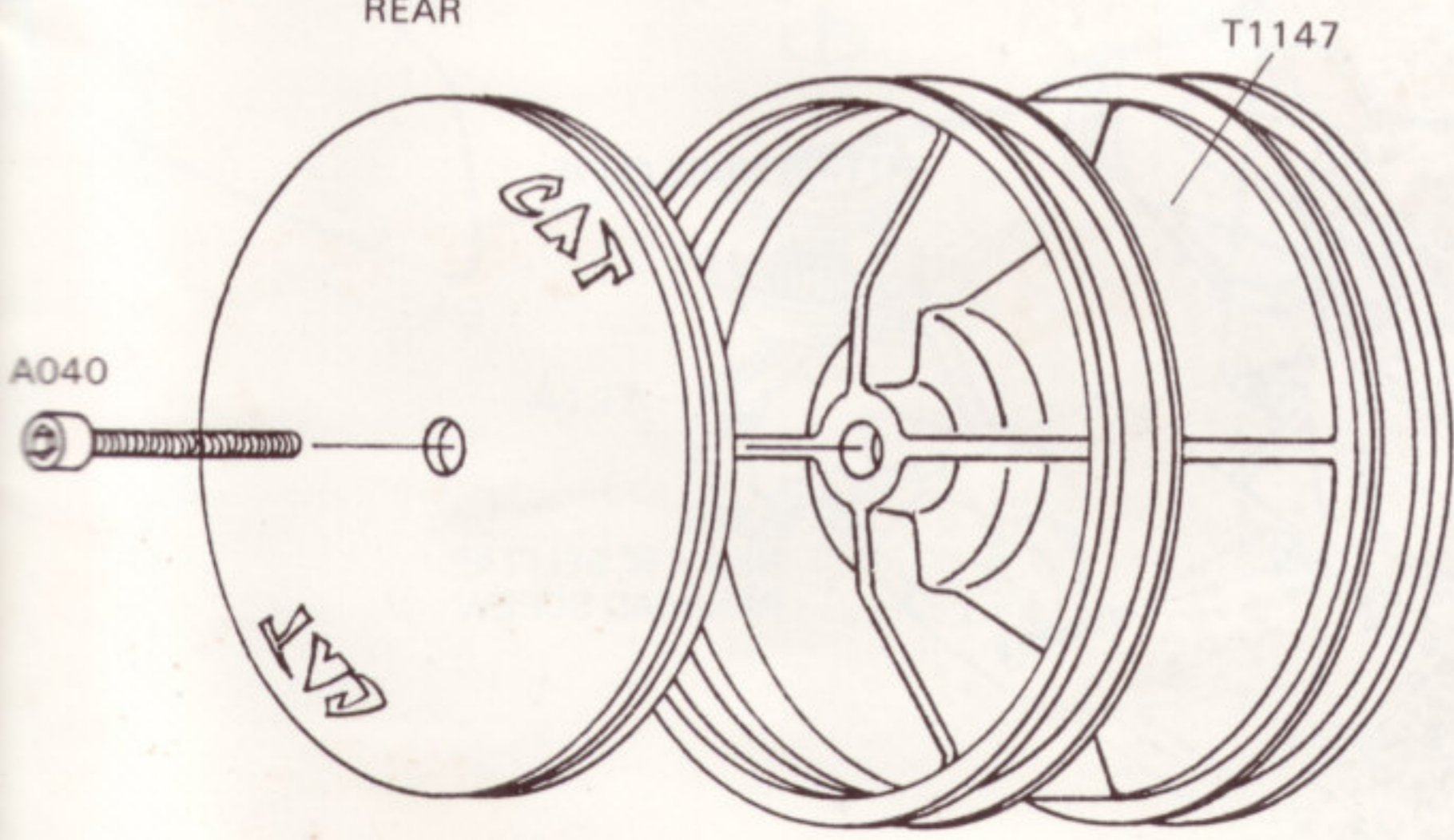

WHEELS CAN BE DYED ANY COLOUR AVAILABLE.

1 CUT AWAY SHADED AREAS.
 USE A FILE OR ABRASIVE PAPER TO SMOOTH THE CUT EDGES.
 ANY RAGGED EDGES OR SCORE LINES MAY CAUSE THE BODYSHELL TO CRACK OR SPLIT WHEN IN USE.
PAINTING: FIRST WASH THE BODYSHELL TO REMOVE ANY OIL OR DIRT. RINSE THOROUGHLY. COVER MOUNTING HOLES WITH TAPE ON OUTSIDE OF BODYSHELL TO PREVENT PAINT GETTING ONTO THE OUTSIDE.
 PAINT THE INSIDE OF THE BODYSHELL AND WING.
 YOU CAN OBTAIN A COLOUR SCHEME BY MASKING A SECTION WITH TAPE, PAINTING THEN REMOVING THE TAPE AND PAINTING A DIFFERENT COLOUR.
 APPLY DARKEST COLOUR FIRST.
 USE DECALS SUPPLIED TO FINISH YOUR BODYSHELL.

BODYSHELL

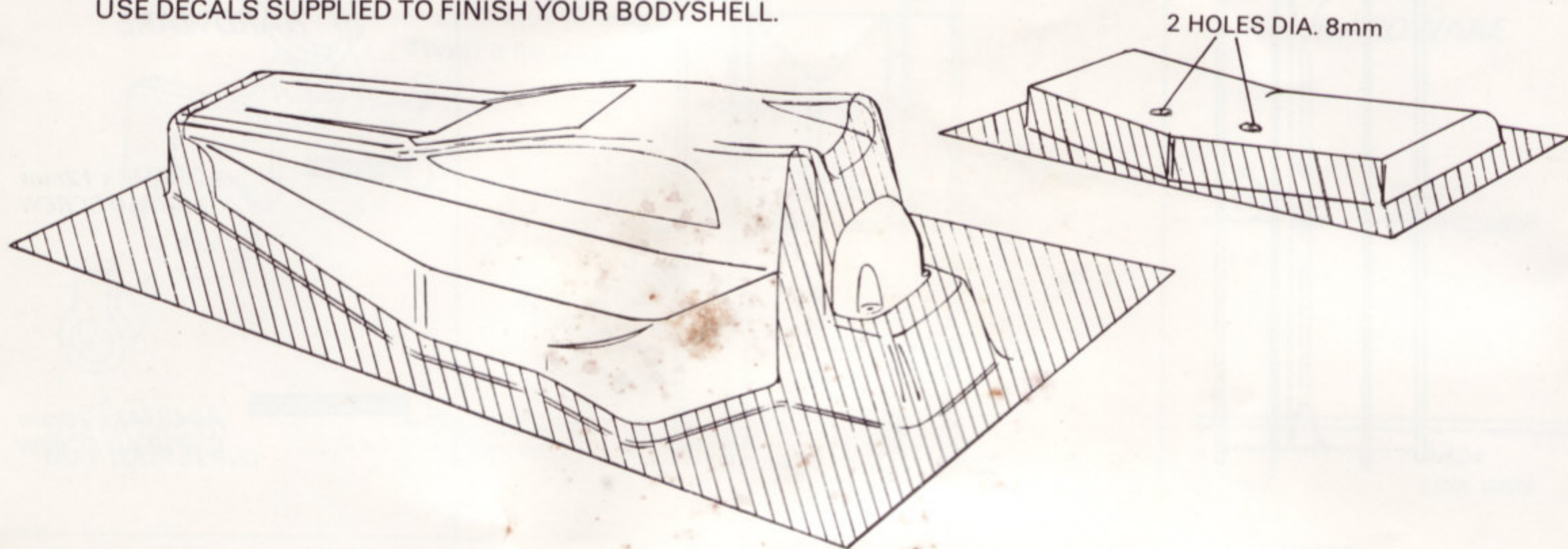

2

FITTING BODYSHELL

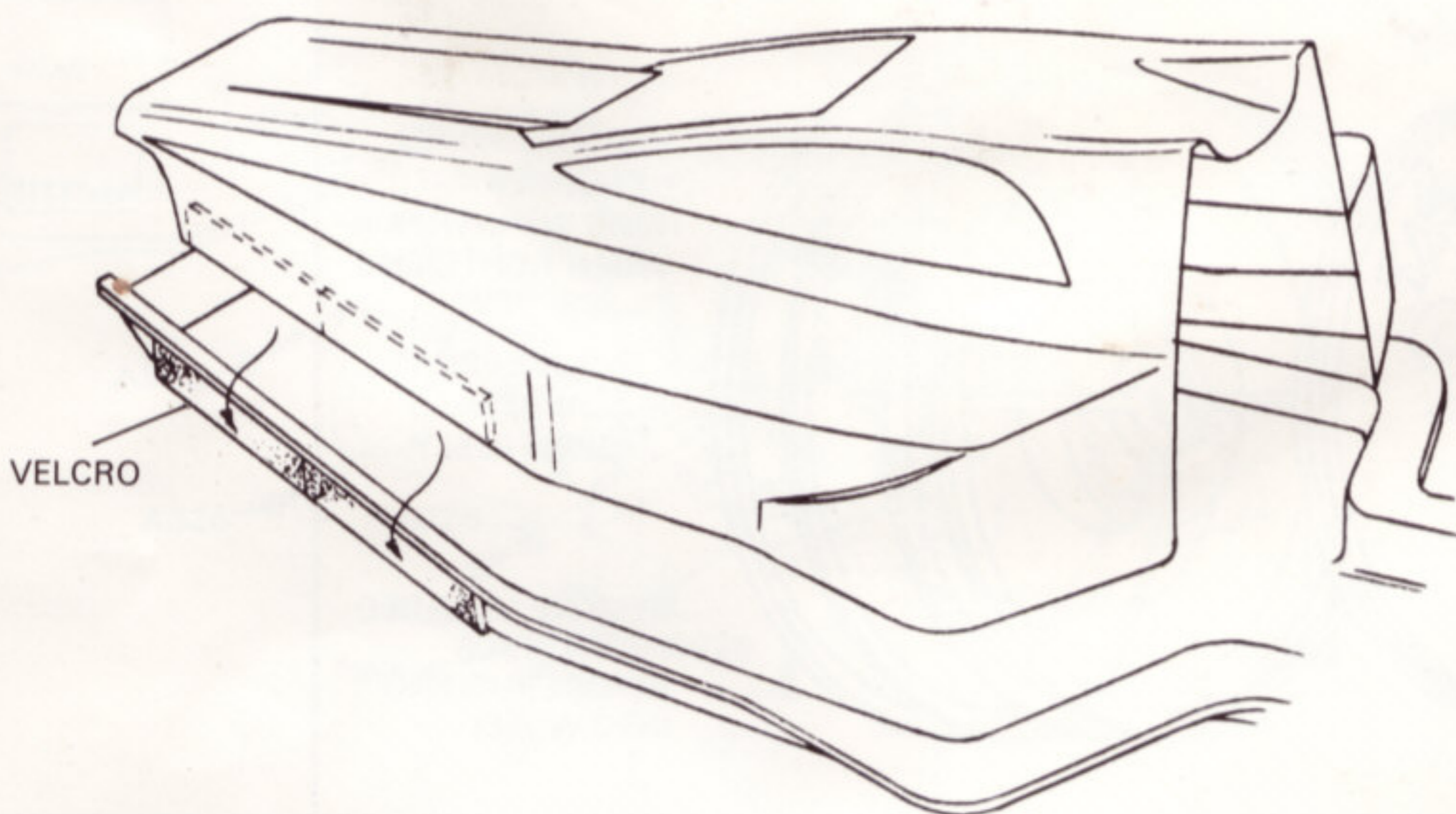

FITTING NOSE CONE

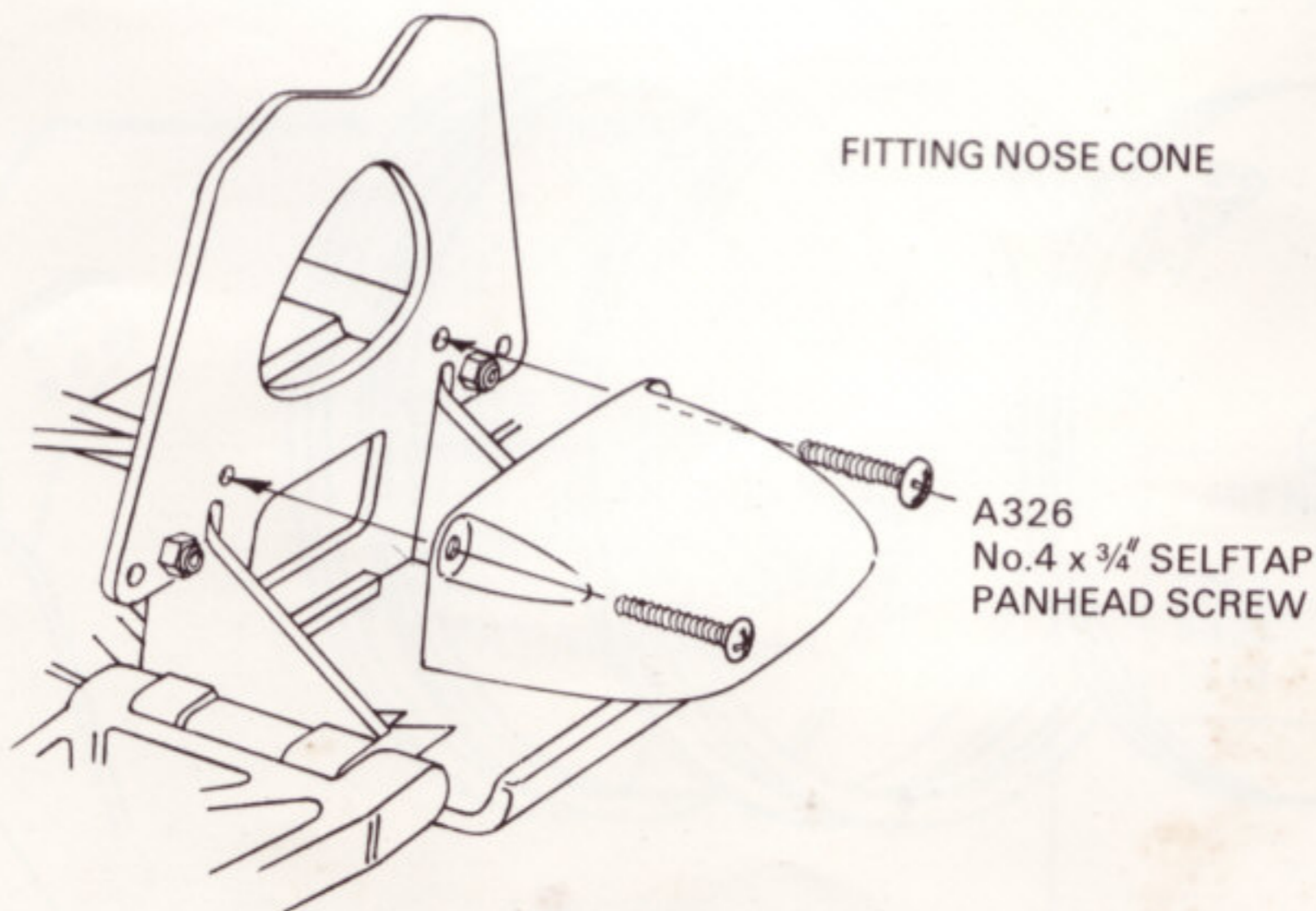

WING MOUNT

1

T1189
WING MOUNT
BRACKET

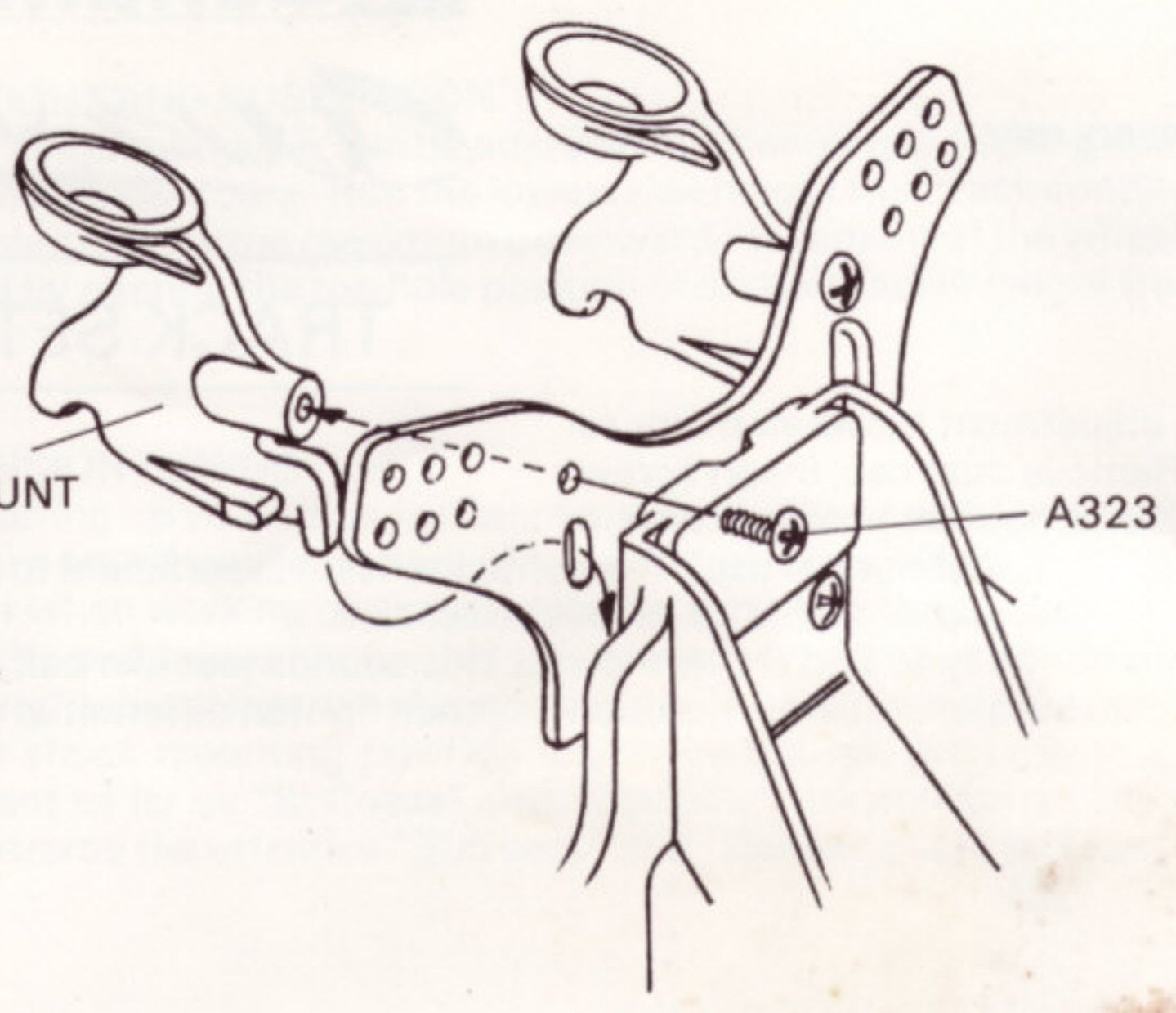

HARDWARE

 A321 No.4 x 1/4"
SELFTAP
PANHEAD SCREW
x 2

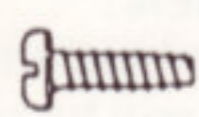
 A323 No.4 x 3/8"
SELFTAP
PANHEAD SCREW
x 2

 A197 WING
MOUNT 'O' RING
x 2

WING ANGLE ADJUSTMENT

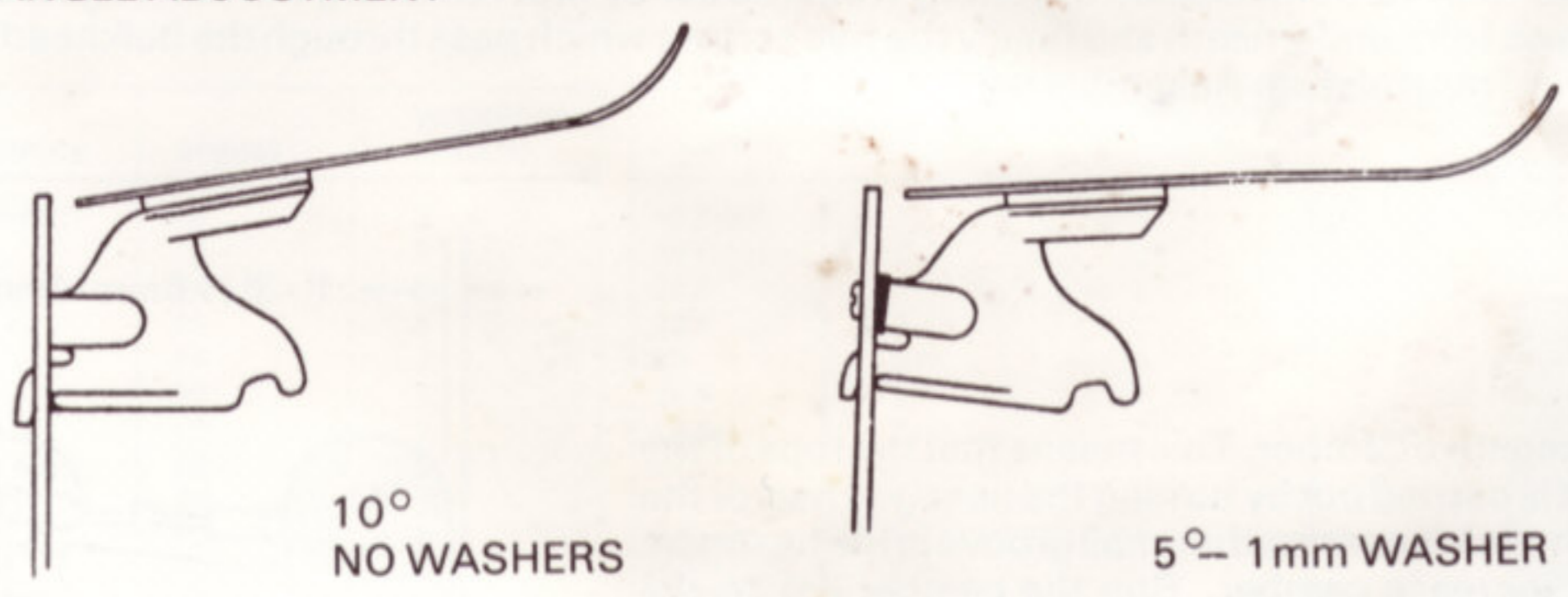

2

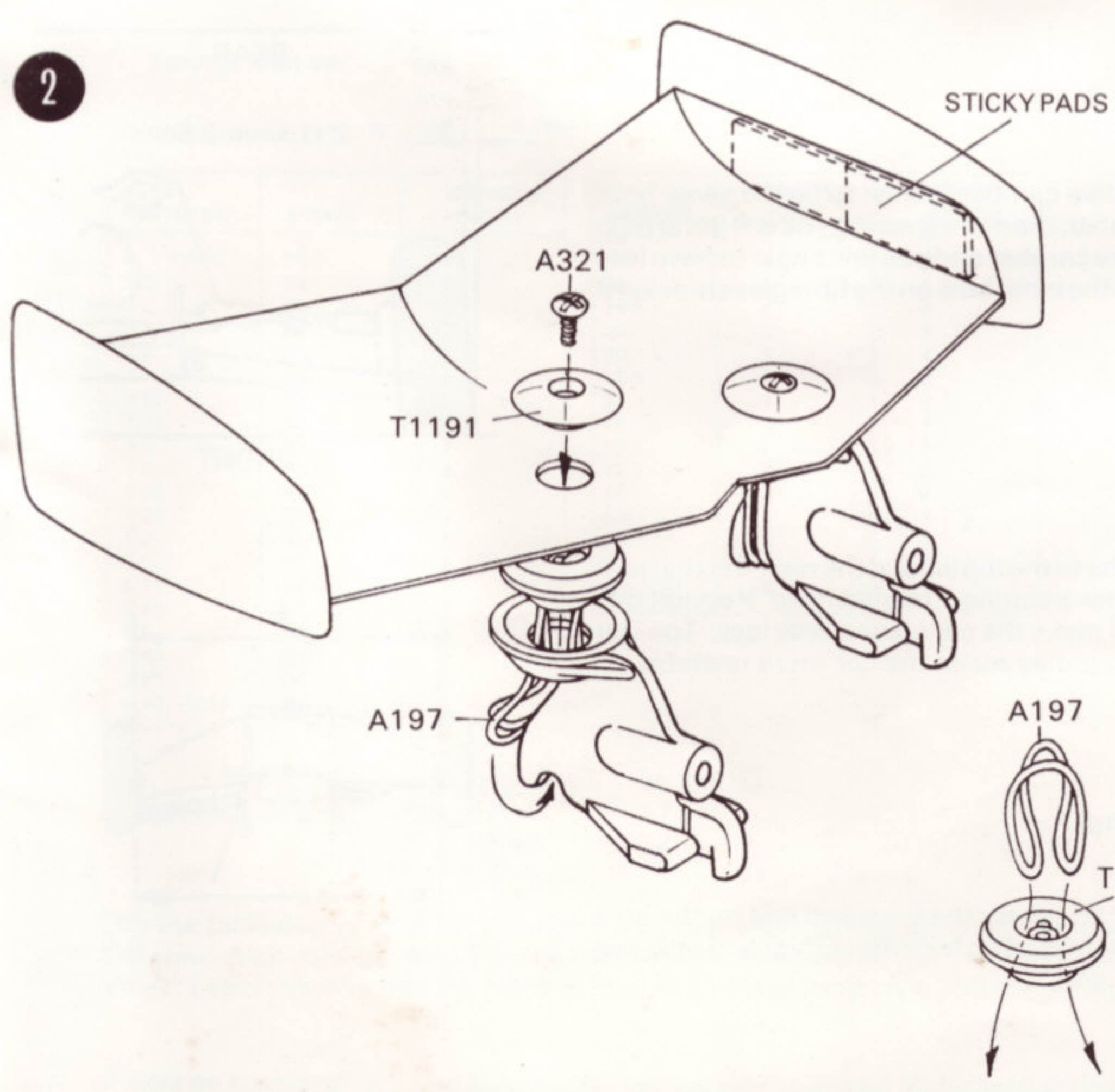

PART No.	SPARES No.
T1189	U832B
T1190	U832B
T1191	U832B
A197	U1247U

TRACK SETTINGS

1 Make sure all screws are tight. Re-check after every race.

2 **DIFFERENTIAL ADJUSTMENT**

In the unlikely event of the differential needing adjustment between major rebuilds, remove universal joint at dust cap end. Remove dust cap, insert screwdriver and rotate opposite rear wheel, clockwise to tighten, anticlockwise to loosen. (45° at a time). The differential should not slip under normal use. The correct tension is sufficient to give enough drive for the prevailing track conditions without slip and without excessive tension. When you first run the car punch the throttle momentarily to find if there is slip, this sounds just like belt slip. If you have correctly adjusted the belt tension (Transmission Assembly section 14) then tighten differential until slip is eliminated.

3 **BELT ADJUSTMENT**

If correctly assembled and adjusted as shown in Transmission Assembly paragraph 14 it is most unlikely that track-side adjustment will be required.

Never run with a slipping belt as both pulleys and belt can be damaged. Belt slip sounds like a tearing noise when the throttle is opened wide. Always recheck differential adjustment first as above because differential slip and belt slip sound very similar. To adjust, remove transmission assembly from the car by first removing the motor guard and then the 4 counter sunk screws from underneath and finally the two screws which pass through the bulkhead. Belt tension is then adjusted as in Transmission Assembly paragraph 14.

4 **REAR-CAMBER**

The rear wheel should be set at negative camber. This means that the tops of the wheel lean inwards. Adjustment is carried out by turning the hexagon part of the top link. The left hand thread of the link is nearest the small groove in the hexagon. Turning this end clockwise will increase camber. Run the camber link to the upper hole of the rear hub carrier if you need more steering.

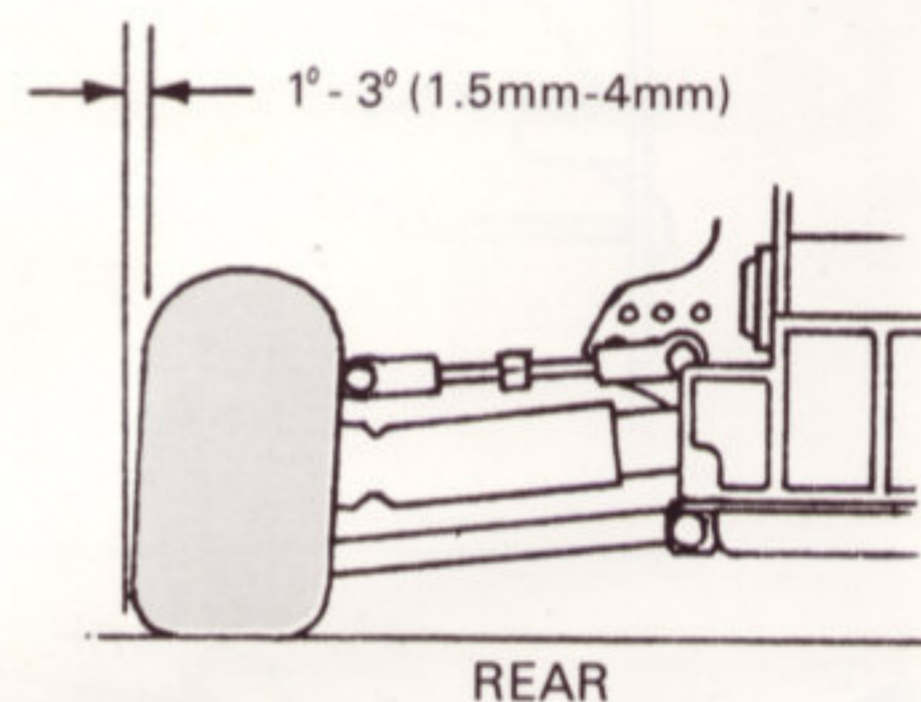

REAR

5 **FRONT-CAMBER**

The front wheels should be set at negative camber (adjust to be the same both sides.) Generally the more negative camber, the more steering you will get at high and medium speeds. Too much negative camber and you will begin to have less steering. Run the camber control link to the inner hole on the fibreglass bracket if you need more steering.

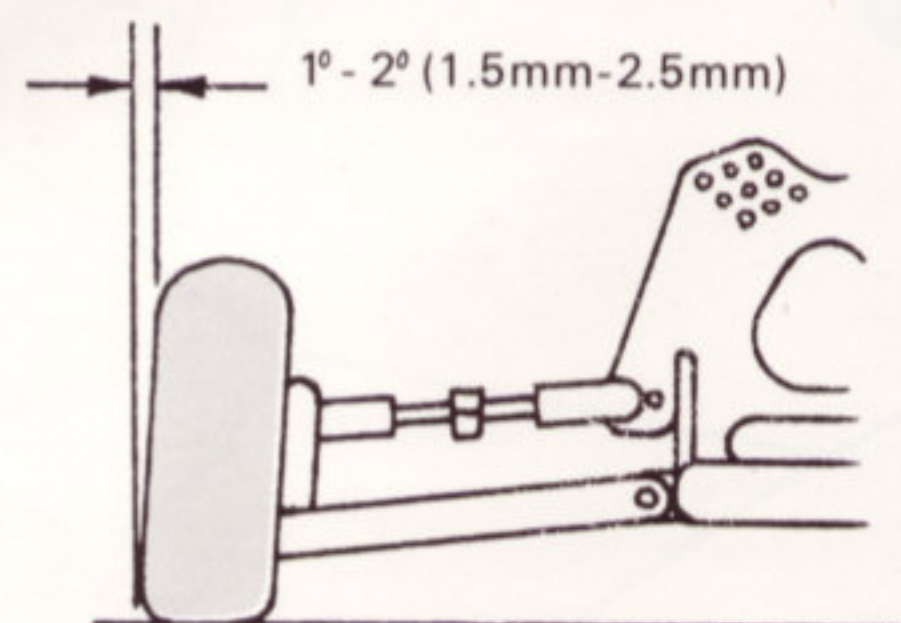

FRONT

6 **TOE IN**

The front track rods are adjustable, similar to the top links at the rear. Set the front wheels up to be parallel to each other when pointing straight ahead. If conditions are slippery add 1-2 deg toe-in this will make the car steer a little less. Toe-out will give more steering at low speed, but may make the car more unstable on corner exit.

A greater than B = toe out.

A less than B = toe in

A equal to B = parallel (standard setting)

ACKERMANN EFFECT

The steering blocks have two holes for attaching the track rod end to, the hole nearest the centre of the car will give increased Ackermann Effect and improve low speed steering and stability on low grip.

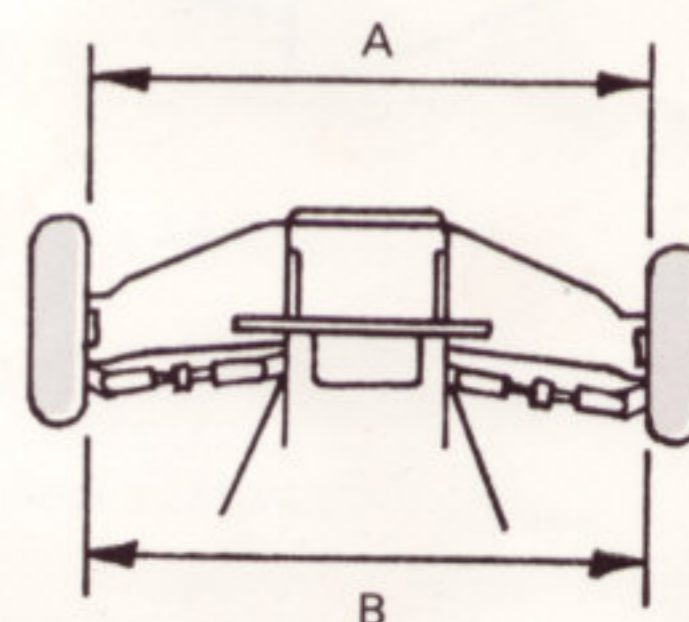

TRACK SETTINGS

7 RIDE HEIGHT AND SUSPENSION

The ride height of the car can be adjusted by changing the spring spacers fitted on the shock absorbers. Run the lowest ride height that track conditions allow. Suspension drop is the maximum downward movement of the wheel. It can be adjusted by altering the top hole position of shock bracket height (rear).

8 SUSPENSION TUNING

When setting up your truck for handling the choice of damping, spring rate and of mounting holes for the shock absorbers are all very important. These factors combine to give you "Stiffness" and "Damping" which you must consider when working on the suspension settings of your truck.

The "Stiffness" tables show what is achieved with various combinations of spring rate and wishbone holes. The "Damping" tables show what is achieved with various combinations of piston holes and wishbone holes.

The top shock mounting position should be chosen primarily to give the required ride height and is not very significant as far as "Stiffness" and "Damping" are concerned. However, as the shock absorber angle becomes more extreme the effective "Stiffness" and "Damping" are reduced slightly.

STIFFNESS	SPRING	WISHBONE HOLE No.	DAMPING	PISTON HOLES	WISHBONE HOLE No.
6 HARD	F6	3	40 STIFF	1	3
4	F6	2	30	2	3
4	F4	3	26.8	1	2
3	F3	3	20.1	2	2
2.7	F4	2	20	3	3
2.5	F6	1	16.8	1	1
2	F3	2	13.4	3	2
2	F2	3	12.6	2	1
1.7	F4	1	10	4	3
1.3	F2	2	8.4	3	1
1.3	F3	1	6.7	4	2
0.8 SOFT	F2	1	4.2 SOFT	4	1

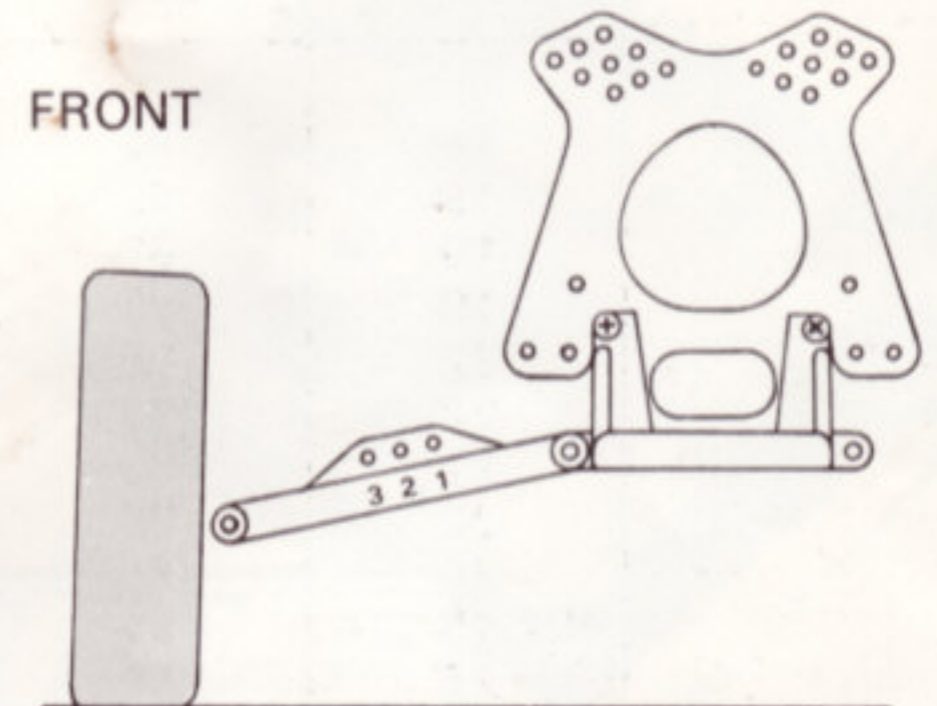

Springs in kit are:

	Free Length	No. Of Coils
M3	54mm	8
M4	48mm	10
M6	44mm	9

STIFFNESS	SPRING	WISHBONE HOLE No.	DAMPING	PISTON HOLES	WISHBONE HOLE No.
4 HARD	R4	4	40 STIFF	1	4
3.2	R4	3	32	1	3
3	R3	4	30	2	4
2.44	R4	2	24.4	1	2
2.4	R3	3	24	2	3
2	R2	4	20	3	4
1.83	R3	2	18.3	2	2
1.76	R4	1	17.6	1	1
1.6	R2	3	16	3	3
1.5	R1.5	4	13.2	2	1
1.32	R3	1	12.2	3	2
1.22	R2	2	10	4	4
1.2	R1.5	3	8.8	3	1
1	R1	4	8	4	3
0.92	R1.5	2	6.1	4	2
0.88	R2	1	4.4 SOFT	4	1
0.8	R1	3			
0.66	R1.5	1			
0.61	R1	2			
0.44 SOFT	R1	1			

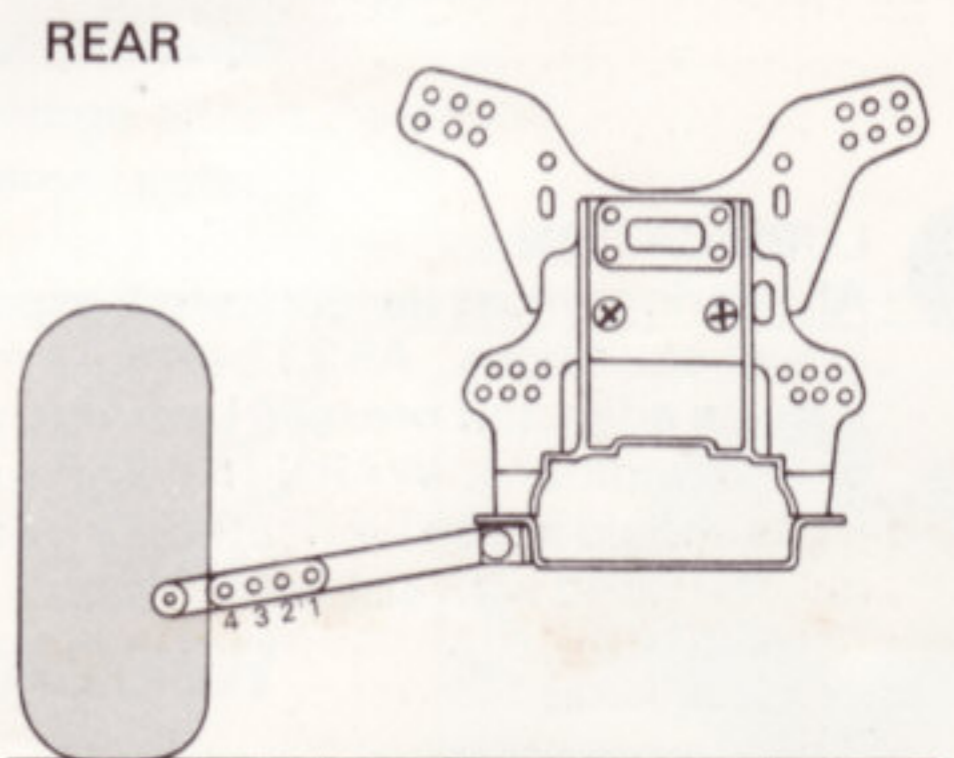

Springs in kit are:

	Free Length	No. Of Coils
R1.5	77mm	12
R2	68mm	12
R4	62mm	11

Use the tables every time you change the suspension settings and record the settings and results for future use. Different wishbone geometry at the front and rear mean that the front and rear tables cannot be related to each other. Experiment to find the settings that suit your driving style and the prevailing track conditions.

A note on spring rates: All Schumacher springs are designated M(medium) or R(rear) and a number which denotes the spring rate as referred to in the charts.

TRACK SETTINGS

- 9 RAKE ANGLE**
 Rake angle, or kick-up in your COUGAR 2 is adjustable, this angle is also the castor angle, less castor will give more turn-in but less steering on corner exit. (see front suspension page.)

- 10 TYRES**
 The front and rear tyres in the kit will give safe predictable handling for normal conditions. However, Schumacher CAT ranges of tyres offer a wide range of options to cover all extremes of operating conditions. The spikes on the tyres may be cut to adjust the handling.

- 11 GEAR RATIOS FOR 5 MINUTE RACE DURATION USING 1700 SCE NICADS.**

Pinion	Gear	Pinion to gear Ratio	Overall Ratio	Approx. Motor Wind	
19	95	5.000	12.14	11T	 <p>Hot Motor</p> <p>Mild Motor</p>
19	92	4.842	11.76		
19	89	4.684	11.38	12T	
19	86	4.526	10.99	13T	
22	95	4.318	10.49		
22	92	4.182	10.16	14T	
22	89	4.045	9.62		
22	86	3.909	9.49	✓	
25	95	3.800	9.23	15T	
25	92	3.68	8.94		
25	89	3.56	8.65	16T	
25	86	3.44	8.35		
28	95	3.393	8.24	17T	
28	92	3.286	7.98		
28	89	3.179	7.72		
28	86	3.071	7.46	19T	

- 12 LUBRICATION**
 All bearings must be lubricated, especially during wet weather. Always remove bearings and clean after running in wet conditions. A533 ballraces may be cleaned by carefully removing the seals with a knife blade under the outside edge and pressed back into place after cleaning. Black contact seals may be removed to reduce drag in clean conditions. **WARNING:** Some aerosol oils and degreasers will expand bearings seals causing drag. Plastic parts should not be lubricated. Drive belts **MUST NOT** be lubricated. Ball differentials and thrust races should only be lubricated with silicone grease.

- 13 GENERAL**
 In general the car should understeer - this means the front wheels slide more than the rear wheels during cornering. You can get this by cutting the spikes of the front tyres down. It helps to have two or three sets of front tyres with different levels of spikes to test for the best option.
 Run the lowest ride height that track conditions will allow - a low car always corners better than a high car. Use the softest damper settings that stops the wheels from bouncing. It is very easy to over damp the car and cause bouncing at speed.

FLASHPOINT



A range of nicads backed by the expertise of Schumacher to offer you a range of quality nicad packs at an affordable price. They are available in SCE1700 or SCR1400, made up into stick or saddle packs and in three colour ranges.

PINK: TEAM SELECTED AND MATCHED

We will only sell these packs if they come up to the standard required by Team Schumacher. If you buy these you will be getting the same quality as the team drivers use. Quantities may be limited but our standards will be very high.

ORANGE: COMPUTER SELECTED AND MATCHED

These packs are carefully selected and matched to Schumacher's own specification to provide high levels of performance and a good tight match for maximum punch, duration and power.

BLUE: COMPUTER MATCHED

These nicads are matched to the same high tolerances as all Flashpoint packs and the quality and performance is what you have come to expect from Sanyo nicads.



TRACO

TRACO - TRACTION CONTROL ESC

- * High frequency FET switching
- * ABS - Antilock Braking System
- * Pushbutton programming of all settings. No screwdrivers.
- * LED indicator for neutral. Full power and interference.
- * Programmable acceleration rates and braking.

PC2

PEAK CHARGER

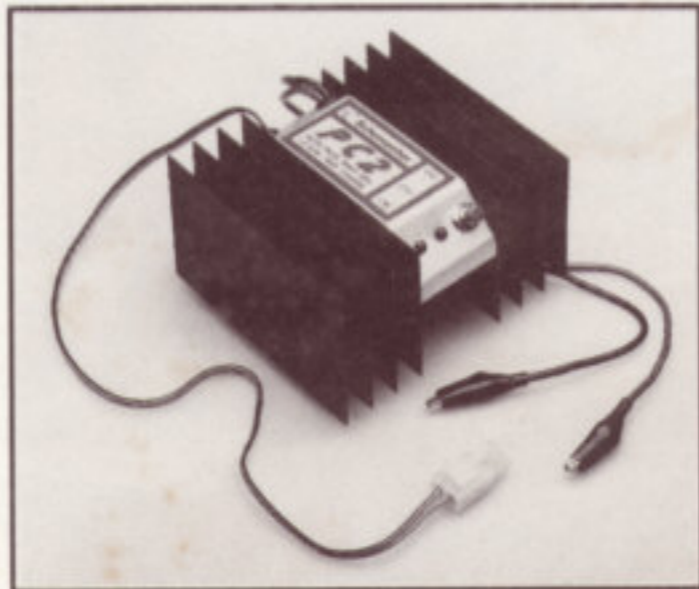

- * Fast 5amp charge nicads from a 12V battery.
- * Auto Cut Off as temperature rises at full charge.
- * Trickle Charge & Full Protection.
- * Simple Internal adjustment of charge current for SCE's.
- * OK Indicator shows connections all correct.

FLASH MOTORS



Modified motor with twin precision ballraces and adjustable timing for seniors competition use.

- NEW - Increased thickness of can for improved magnetic performance
- NEW - Stronger wet magnets for increased power and resistance to heat damage.
- NEW - Machined aluminium end bell for improved heat dissipation.

- FLASH 2 - Designed for maximum RPM
- FLASH 4 - Designed for maximum torque



NIMS

NICAD MANAGEMENT SYSTEM

*** CHARGE - DISCHARGE - CYCLE***

- * Peak and temperature charge 25-60°C
- * Constant current charge 2.5-8.0 amps.
- * Data storage for 9 packs.
- * Constant discharge current 10 amps.
- * Multiple programmed cycles.
- * Soft total discharge.
- * Boost charge after auto cut-off.
- * Overcharge protection.
- * Full short and reverse protection.

PC5

PEAK THERMAL CHARGER

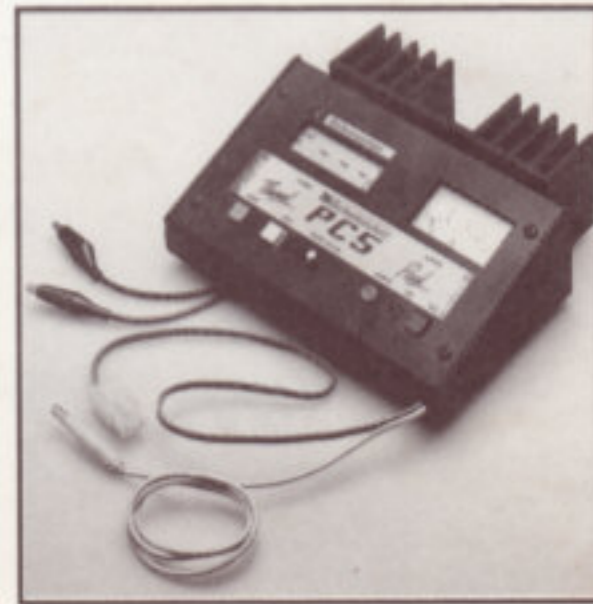

FEATURES:-

- * Peak detect auto cut off
- * Thermal cut off - fully adjustable 0-69C
- * Temperature display in thermal mode
- * Adjustable fast charge rate - 2.5-6 amps
- * Clear ammeter display for full confidence
- * Strong metal case
- * Fully protected against wrong connections
- * May be used from 12v car battery or good quality 12v mains supply.

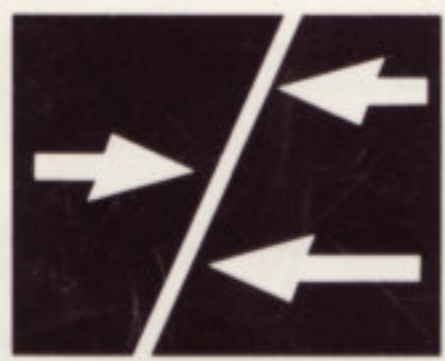

Schumacher

INTRODUCE....

NITRO 10

NITRO 10 - THE NEW SENSATION

Fantastic performance with actual speeds over 40 mph available. Pull start 1.5cu-2.5cc motor with onboard glo supply for easy starting. Pre-assembled motor, clutch and gearbox.

Hit the great outdoors with your Racing Truck or Panther. Cruise the streets with your 911 Sport or 190 Evolution. Have FUN!

**ENGINE INCLUDED
IN KIT.**



ALL YOU NEED IS...



RACING TRUCK



190 EVOLUTION



PANTHER

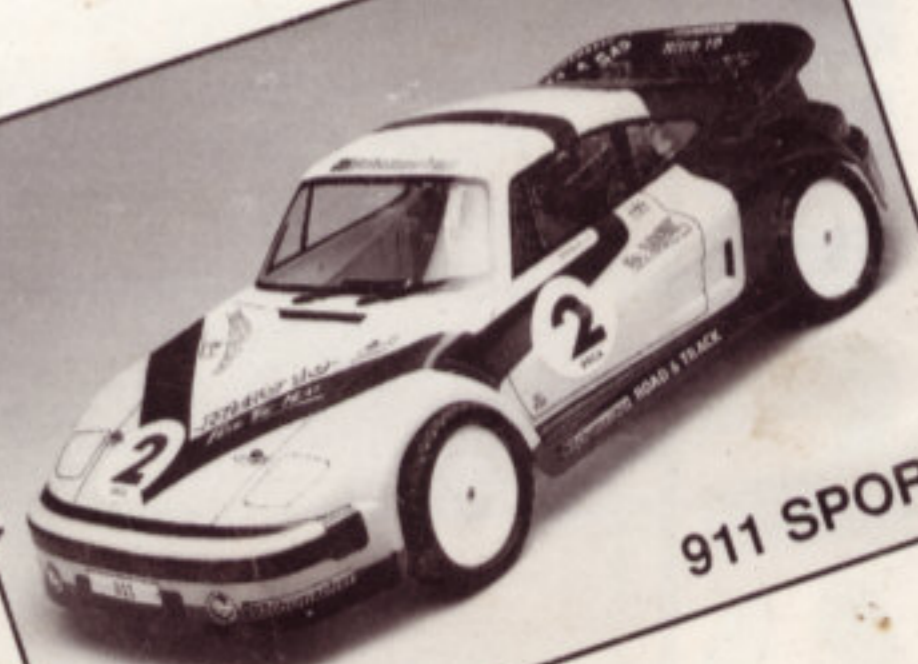

911 SPORT

'IT'S A GAS'

ENGINE: .15 cu-2.5cc IRVINE engine featuring "ABC" piston/liner, ballbearing crankshaft and Schneurle porting to give close to 30,000 rpm. Easy to use recoil pull start.
CHASSIS: Mid engine alloy chassis with fully independent suspension by coil springs and oil filled shock absorbers. Sealed ballbearings are included on all four wheels.
TRANSMISSION: Pre-assembled gearbox with kevlar HTD belt drive and ball differential. Twin ballbearing clutch with PTFE shoes and light alloy flywheel.
INSTRUCTIONS: Detailed step by step instructions covering assembly, maintenance and running.

DESIGNED AND MANUFACTURED BY:



Schumacher

AVAILABLE FROM ALL GOOD MODEL SHOPS

OPEN YOUR MIND, THEN DRIVE IT!