

**TRX**

**ASSEMBLY MANUAL  
TUNING GUIDE**

**MODEL 2701**

**TRAXXAS**

12150 SHILOH RD., DALLAS, TX. 75228

**TRX**  
PERFORMANCE GROUP

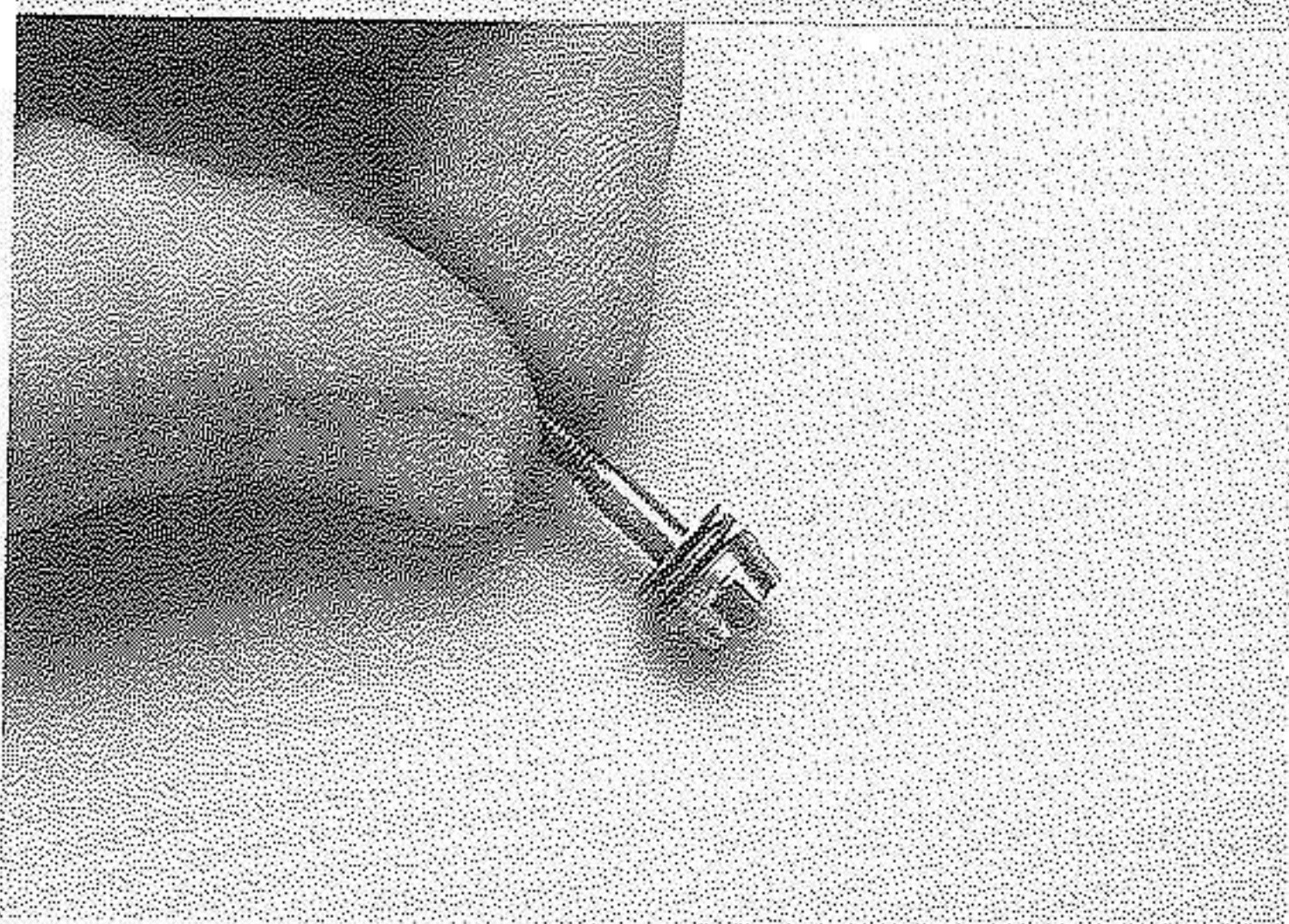
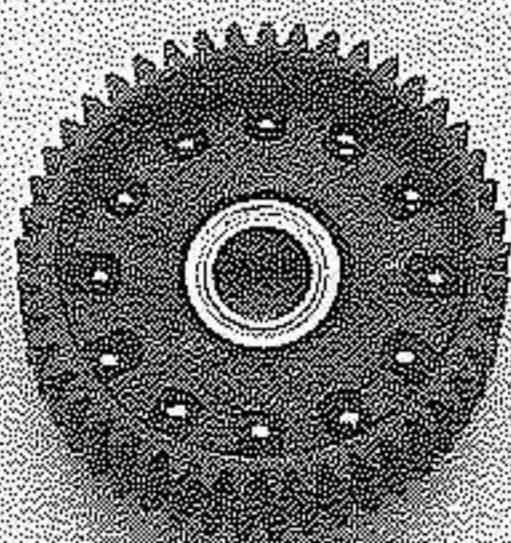
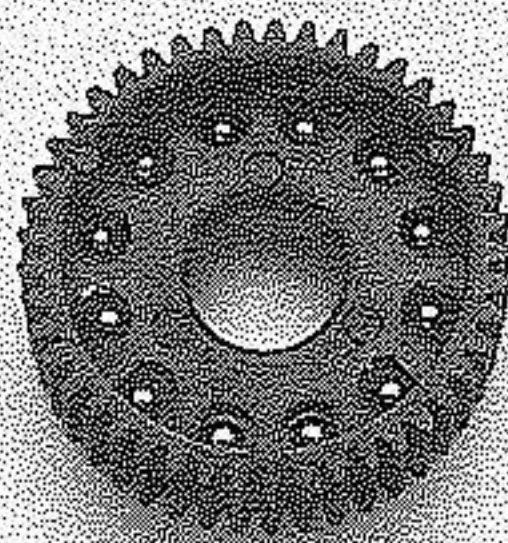
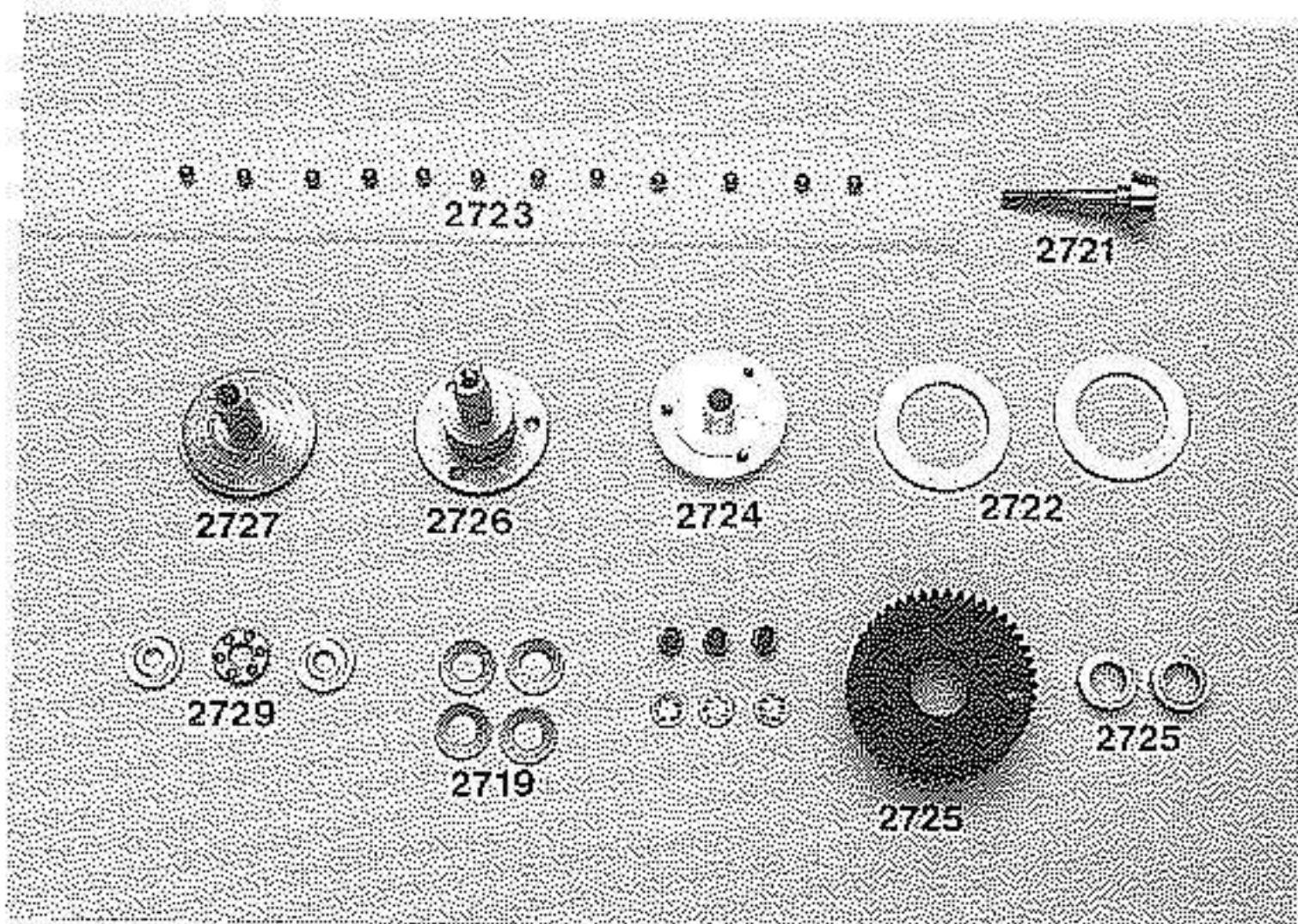
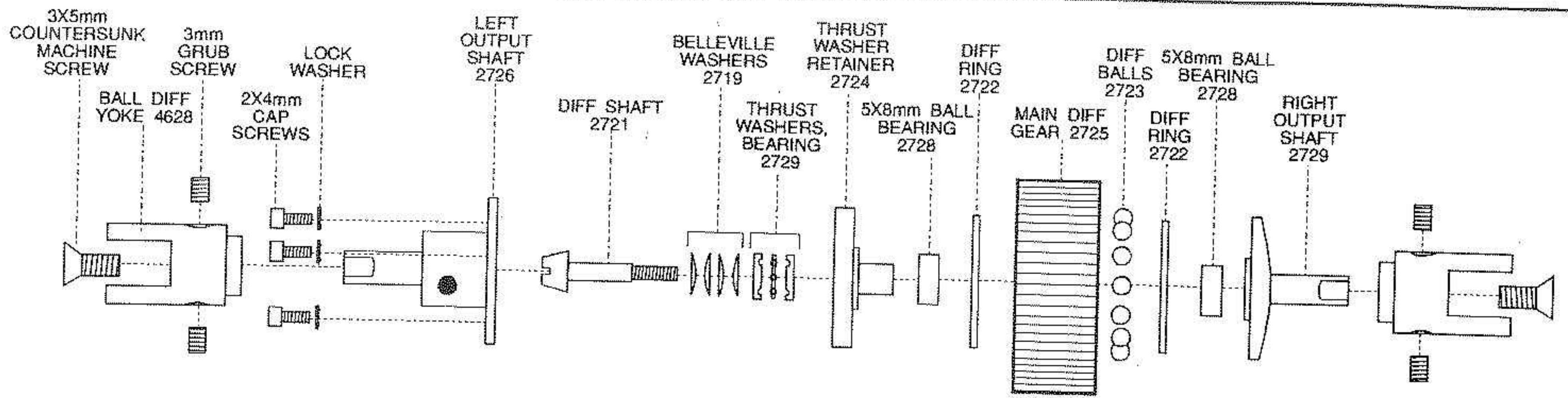

### STEP A-1

This photograph is provided to help you identify the parts of the ball differential by name and part number. In some TRX-1 kits, the ball differential has already been assembled. If yours is assembled, all you need to do is wipe off any excess lubricant which may be on its exterior and move to step A-12. At step A-12 you will want to use the 1.5mm allen wrench and make sure the three 2x4mm cap screws are securely tightened. Keep this manual for reference when it's time to rebuild your differential.

If your differential is unassembled, take a moment now to clean and deburr the metal parts. The metal parts have machining oil on them which needs to be removed with something like motor cleaning spray before assembly.

### STEP A-2

Locate the 45-tooth main diff(differential) gear (2725), the container of diff lube (not pictured), and the (12) 3/32 inch hardened diff balls (2723). Be sure to use a paper plate or a small dish to contain the diff balls during assembly. Begin by packing the tiny holes in the main diff gear with the diff lube. Use your thumb and index finger to squeeze the lube into the holes. Now, snap 1 diff ball into each of the 12 holes in the gear. Use something soft like the end of a pen cap to push the balls into the gear. Finally, on both sides of the gear, place a small dab (about the size of a pinhead) of the diff lube on each ball.

### STEP A-3

Press one of the 5x8mm ball bearings (2728) into the center of the main diff gear. The ball bearing should be centered in the gear so that it protrudes an equal distance from both sides of the gear.

### STEP A-4

Locate the diff shaft (2721), and the four belleville spring washers (2719). Note that one face on each of the belleville spring washers is dished. Place the first washer over the end of the diff shaft with the dished side facing towards the base of the shaft. Place the second spring washer over the diff shaft with the dished side facing away from the head of the diff shaft. Repeat this sequence for the remaining pair of belleville spring washers.

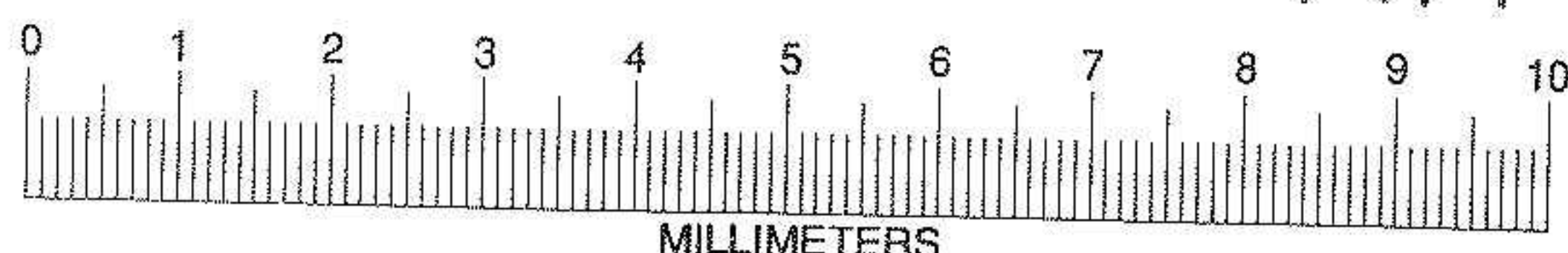
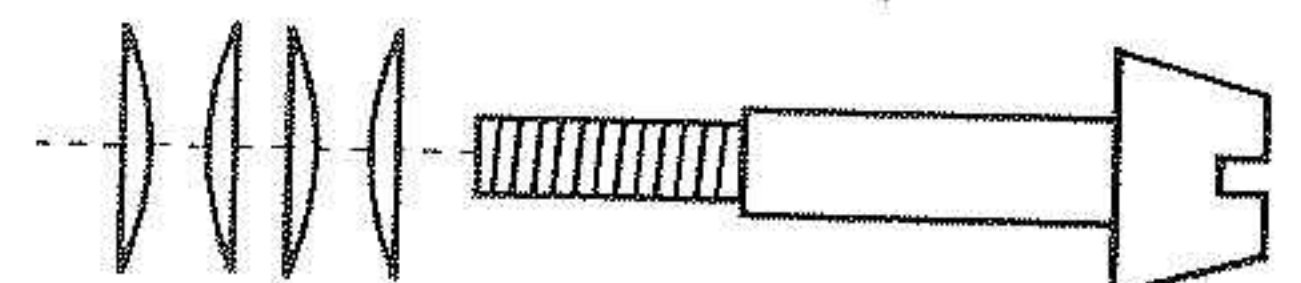

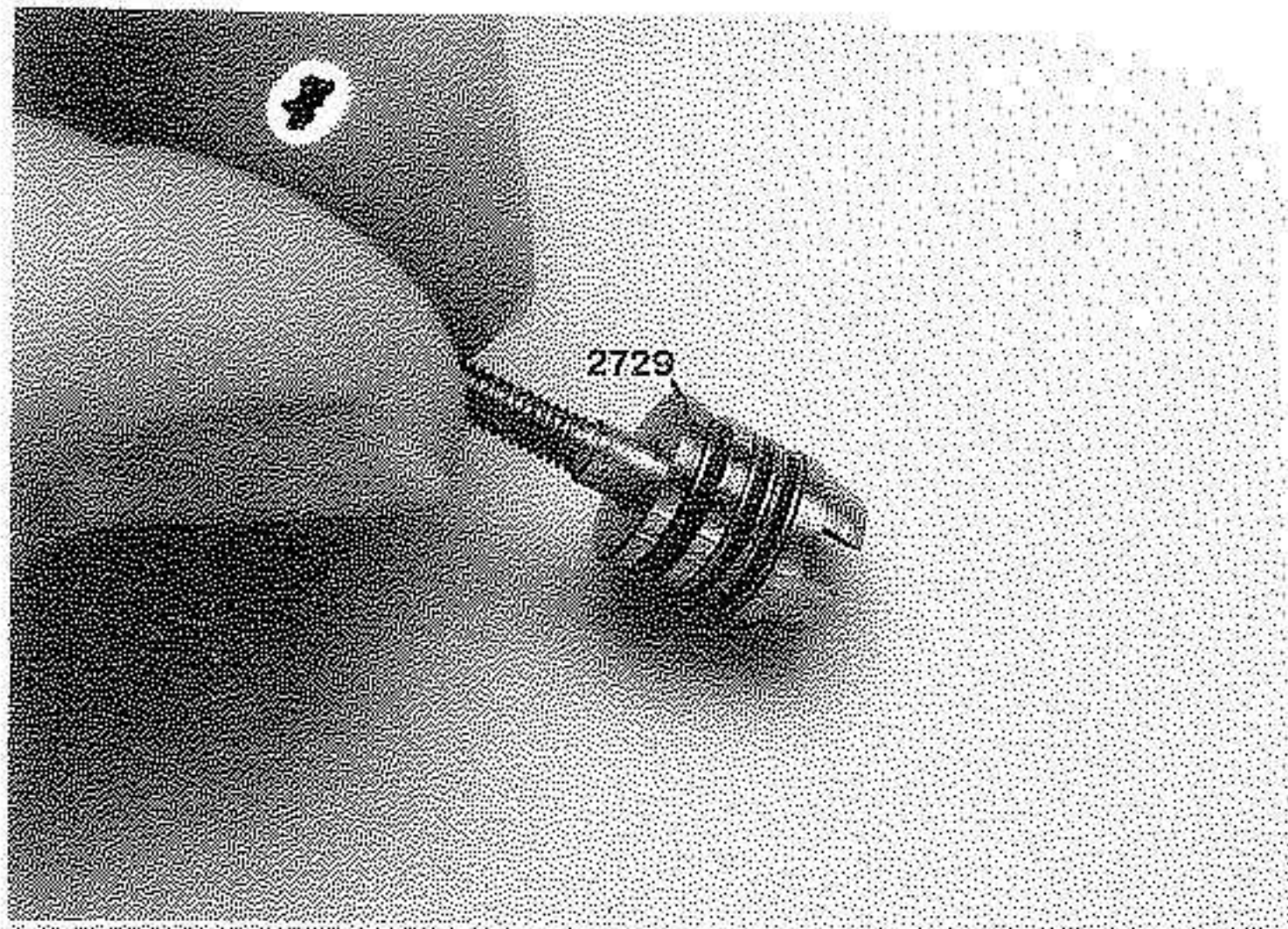

### STEP A-5

Locate the two grooved thrust washers (2729), the 3x7.5mm thrust bearing (2729) and the container of thrust bearing grease. Smooth a thin layer of the thrust bearing grease into the grooves on both of the thrust washers. Place one of the thrust washers onto the diff shaft with the grooved side facing away from the head of the shaft. Place the thrust bearing onto the shaft and seat the balls into the groove of the first thrust washer. Place the remaining thrust washer onto the diff shaft so that the grooved face will seat against the thrust bearing.

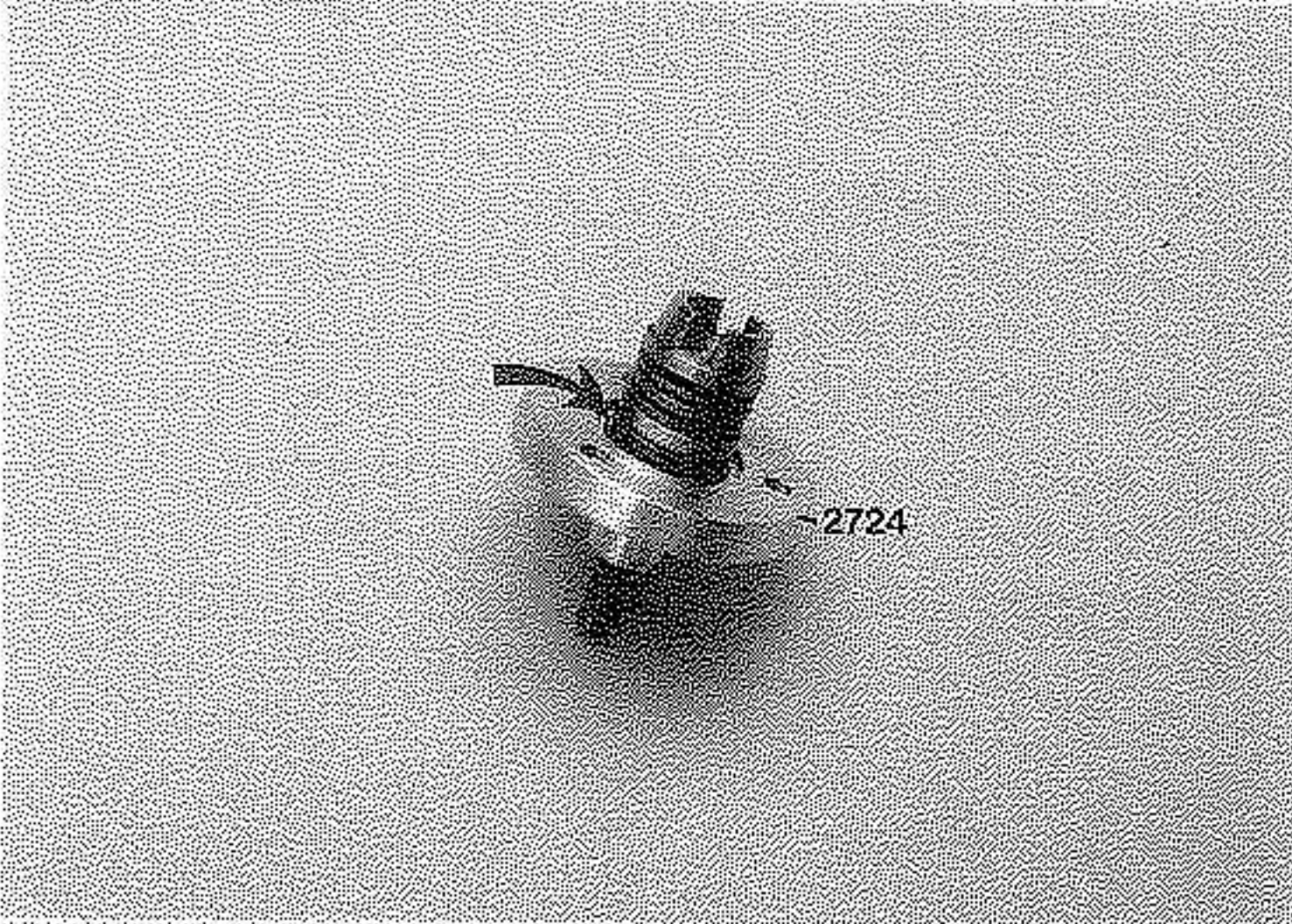
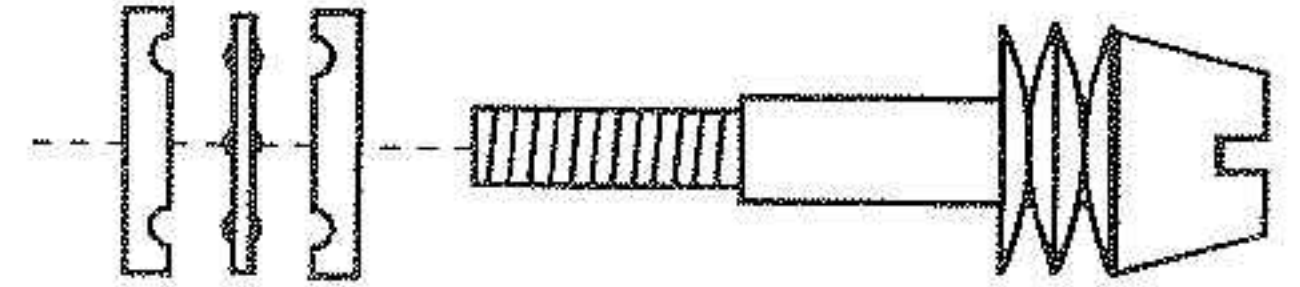

### STEP A-6

Locate the aluminum thrust washer retainer (2724). Insert the threaded end of the diff shaft assembly from Step A-5 through the center of the flat side of the thrust washer retainer. The outermost thrust washer on the diff shaft will seat perfectly into the thrust washer retainer (arrow).

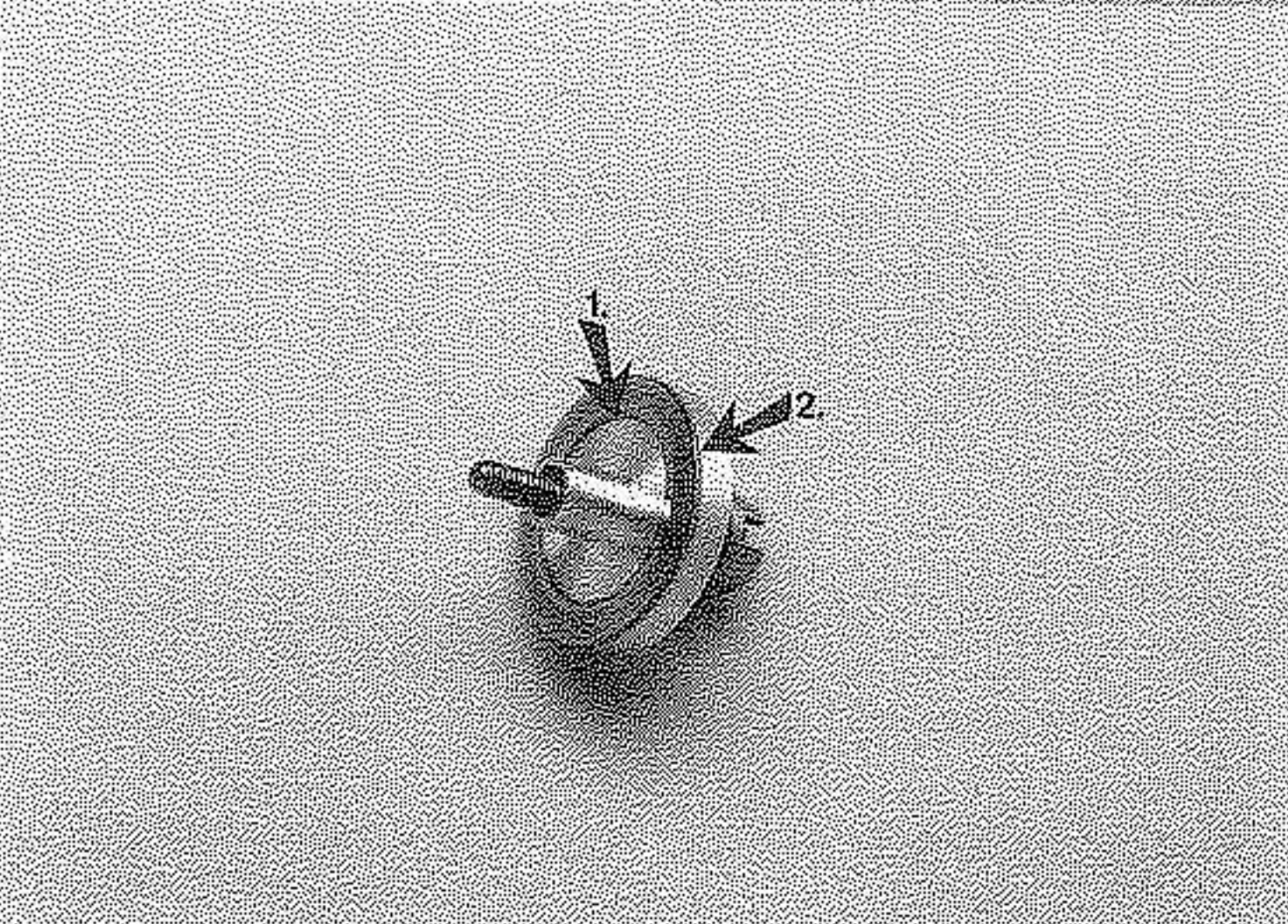

### STEP A-7

Locate one of the 19mm diff rings (2722). Examine it carefully and notice that one edge is slightly rounded while the other is sharp and square (see drawing). Place the diff ring onto the extruded face of the aluminum thrust washer retainer so that the rounded edge of the ring will face the diff gear. The retainer is machined so that the diff ring will fit exactly onto the center section (arrow 1). There should be no gaps between the aluminum retainer and the diff ring (arrow 2).

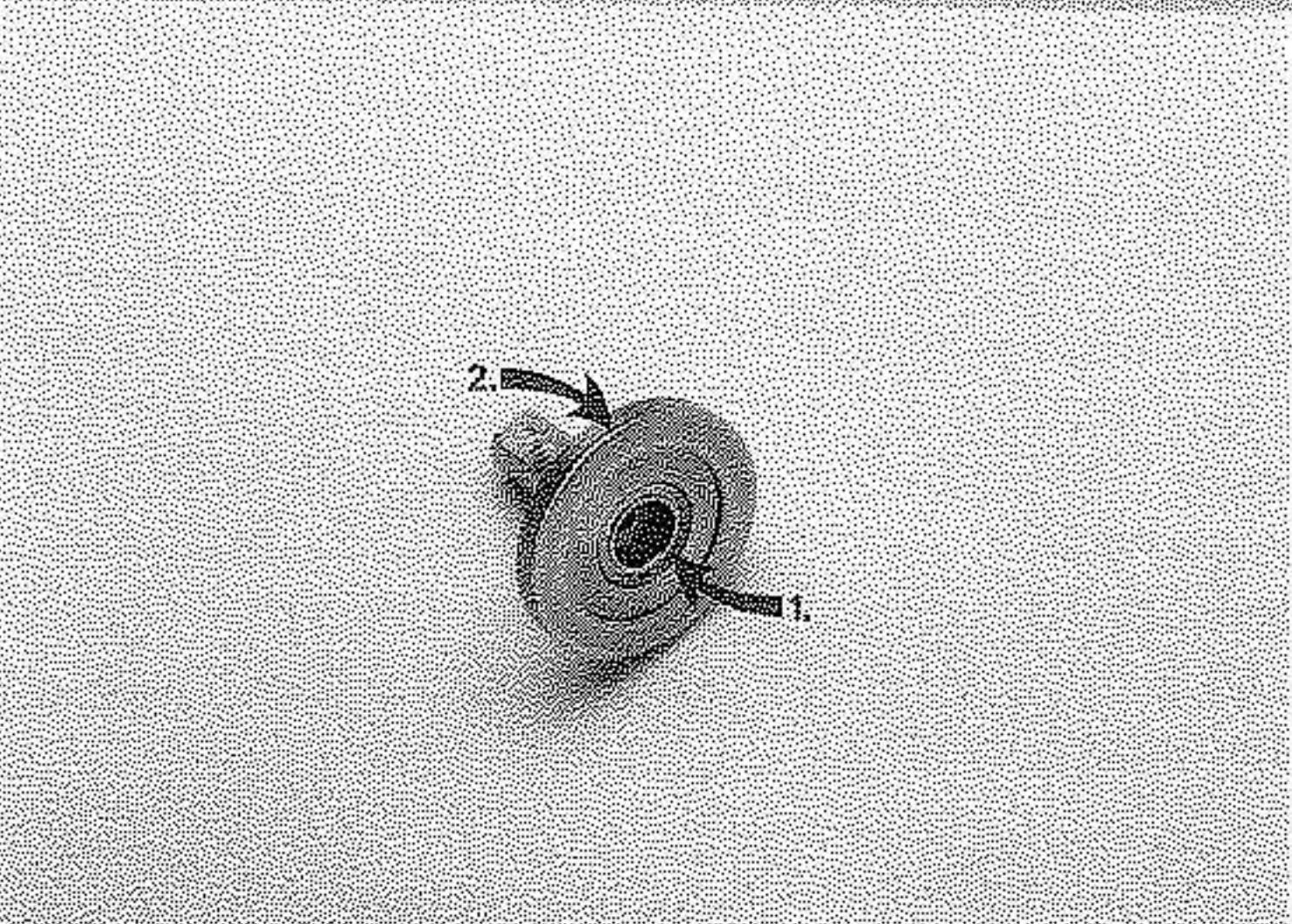

### STEP A-8

Locate the right output shaft (2727), the remaining 5x8mm ball bearing (2728), and the remaining diff ring (2722). Press the ball bearing into the center of the right output shaft as shown (arrow 1). Now press the diff ring onto the face of the shaft so that it fits flush against right output shaft, and the rounded edge will be against the main diff gear. If the ring will not stay fixed to the output shaft on its own, place a small drop of very thin Superglue between the output shaft and the diff ring. Make sure any glue used spreads evenly so that there are no gaps between the output shaft and the ring (arrow 2).

### STEP A-9

Locate the retainer and diff shaft assembly, and the main diff gear assembly. Press the aluminum retainer into the ball bearing and through the center of the main diff gear. Push it in until the diff ring contacts the diff balls.

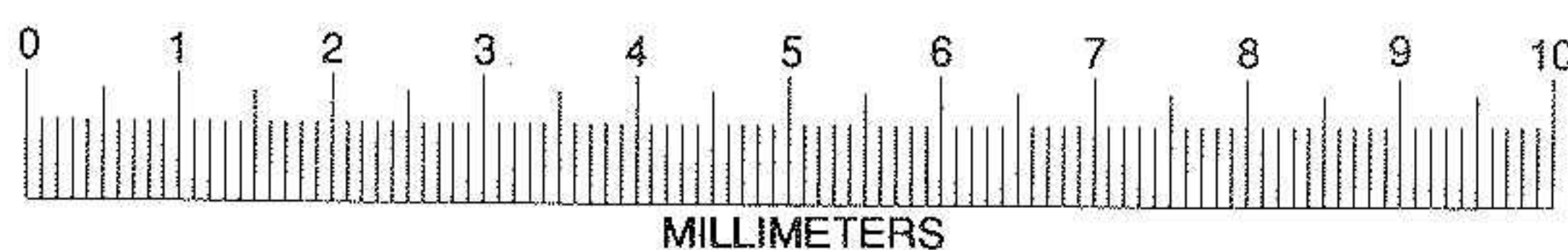
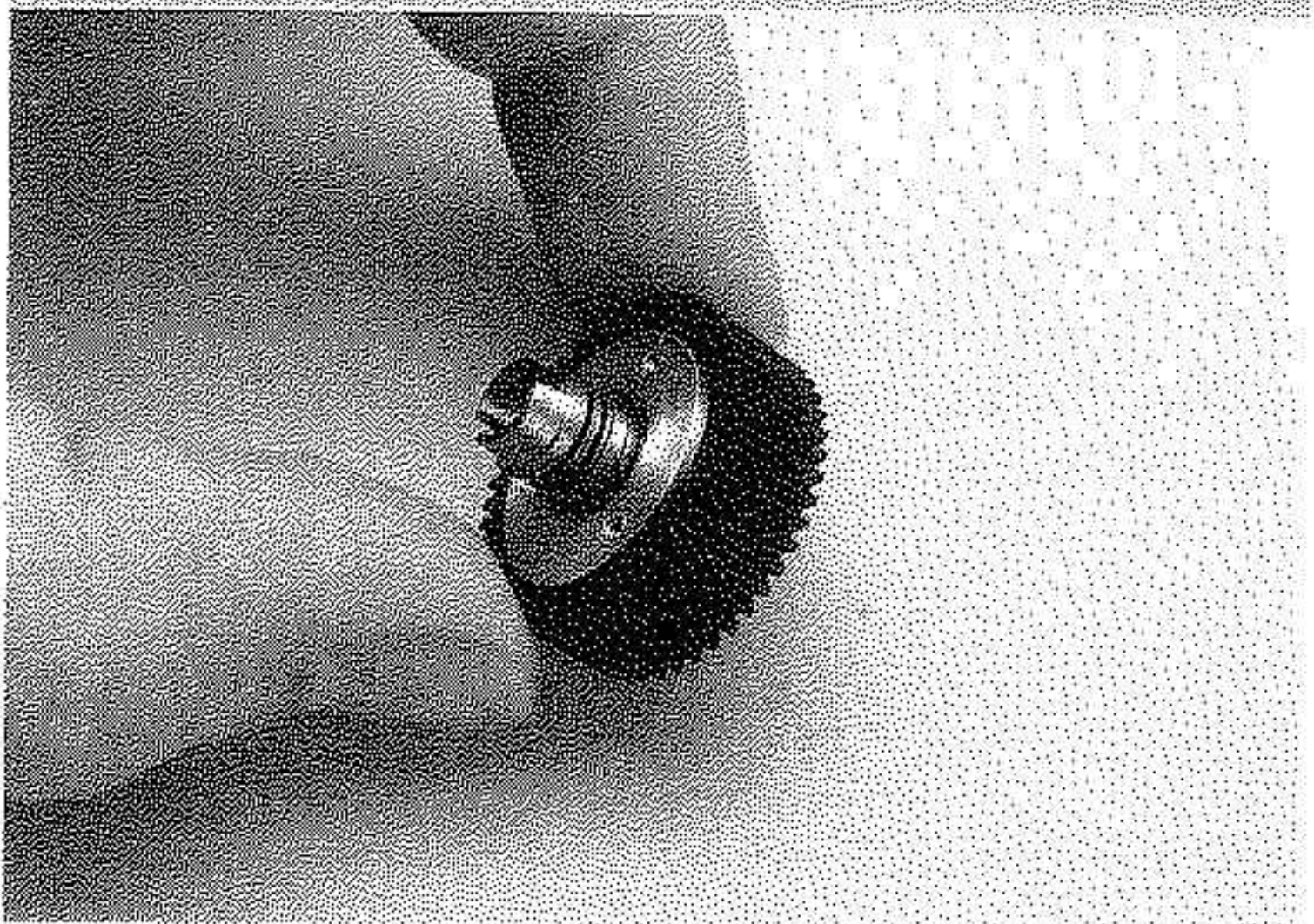

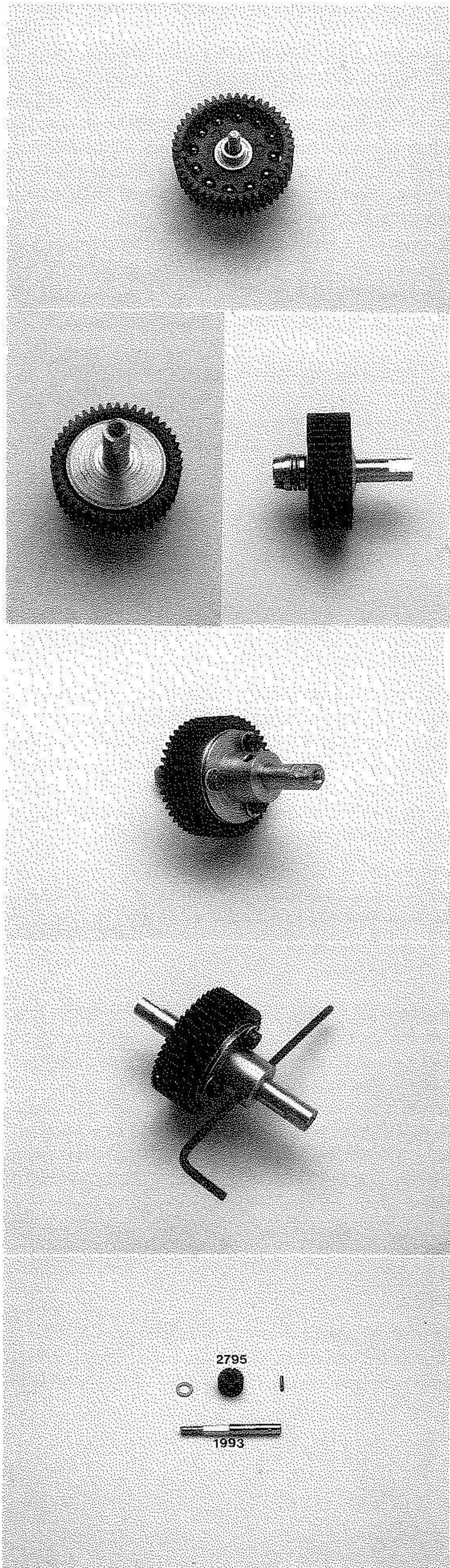

### STEP A-10

Turn the diff assembly over so that it is resting on the head of the diff shaft.

### STEP A-11

Locate the right output shaft assembly from step A-9. Screw it down onto the diff shaft until the diff is very stiff and hard to spin, or until the threads bottom out. As you are screwing it down, pay very close attention to the belleville washers to be sure that they have seated properly against their stop on the diff shaft. Now, back the adjustment off between 1/4 and 1/8 of a turn. This should be very close to the correct adjustment. Final adjustment will have to be made once the car is assembled.

### STEP A-12

Locate the left output shaft (2726), the three 2x4mm cap screws, and the three 2mm star washers. Position the left output shaft onto to the aluminum thrust washer retainer so that the three holes on each line up. Slide one star washer over each of the 2x4mm cap screws, and then place a small drop of thread locking compound on the cap screw threads. Now use the cap screws to fasten the left output shaft to the thrust washer retainer. Tighten them firmly but be careful not to overtighten.

### STEP A-13

The differential is now assembled. Check it at this time for smooth operation. Also, take a moment to study how the external adjusting mechanism works. Focus your attention on one of the small holes in the side of the left output shaft. Hold the left output shaft and spin the gear until a clear pathway can be seen through the hole. Insert the 1.5mm allen wrench that came with your kit into the hole. This locks the diff so that it can be adjusted. To change the adjustment, turn the right output shaft. Once the diff is installed in the car, you will be turning the right rear wheel to make this adjustment.

## BAG B

### STEP B-1

Locate the slipper shaft (1993), the 9.5mm roll pin (1993), the 21-tooth slotted top gear (2795), and a 5x8mm fiber washer.



5X8mm FIBERWASHER

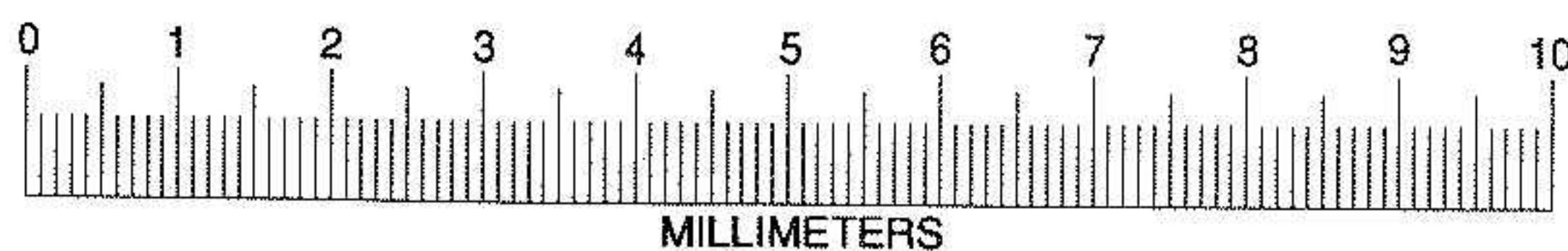

MILLIMETERS

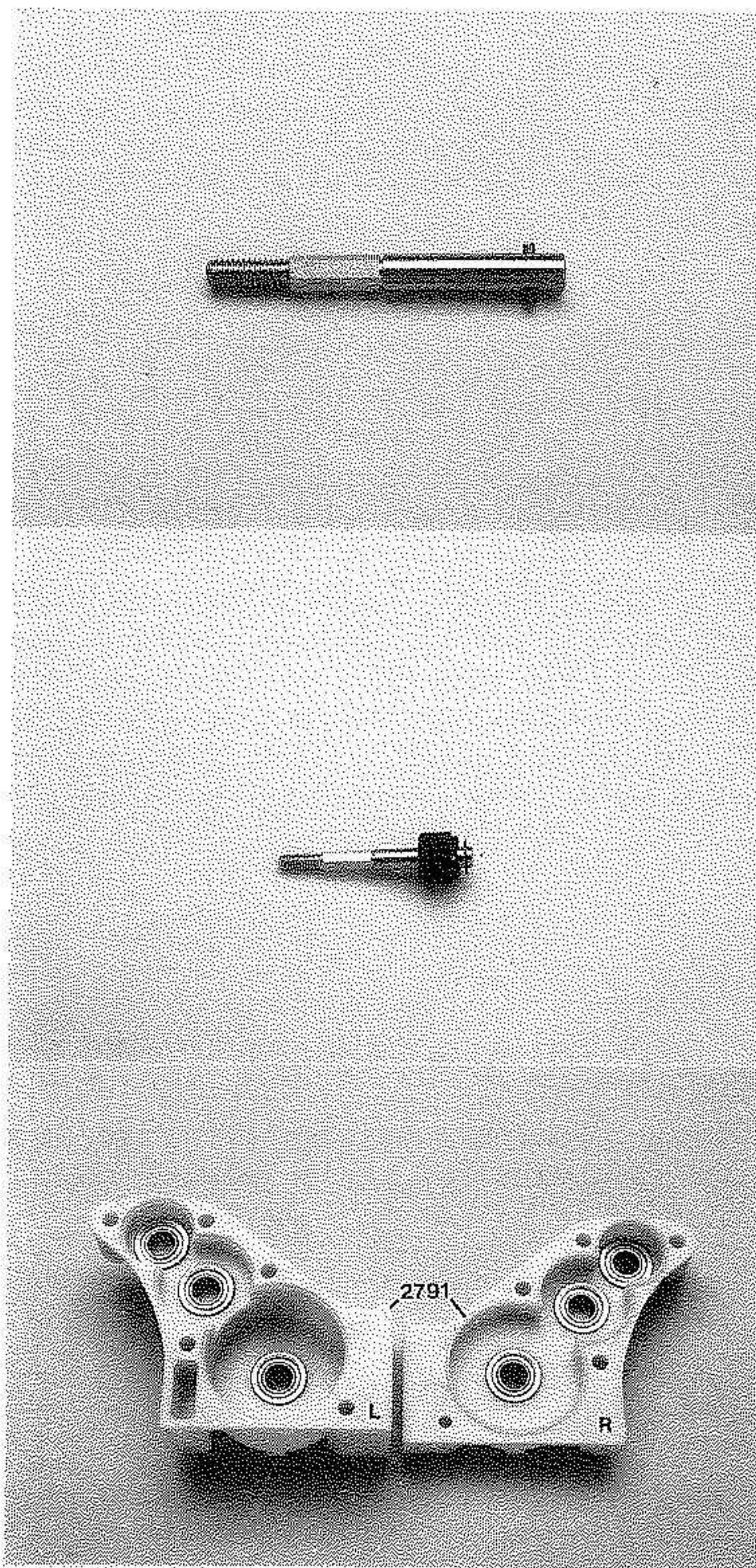

### STEP B-2

Examine the roll pin and note that the ends are beveled. Use the end which appears to be most beveled to start the pin. Support the slipper shaft on a hard surface. If you have a vise available, close the jaws until there is only a 1/16 inch gap between them, and then lay the slipper shaft horizontally in the gap. Start the roll pin into the hole by holding it with a pair of needlenose pliers, and tapping it gently with a small hammer. Tap the pin through until it protrudes an equal distance from both sides of the shaft. Avoid actually clamping the shaft in a vise or locking pliers. Clamping will leave teeth marks on the shaft thus making it unusable.

### STEP B-3

Slide the top gear onto the shaft until the notch in the face of the gear bottoms out on the roll pin. The gear will probably be extremely tight on the shaft. This task is easiest to perform with a vise and the plastic hammer. Open the vise just wide enough that the slipper shaft can be inserted between the jaws without touching. Place the top gear over the open jaws and then use the plastic hammer to tap the shaft through the gear. DO NOT use a metal hammer because it will cause the end of the slipper shaft to "mushroom", making it impossible to get the bearing onto the shaft. Check to be sure that the roll pin does not protrude far enough on either side to interfere with the gear mesh. Place a 5x8mm fiber washer over the end of the slipper shaft, against the roll pin.

### STEP B-4

Locate the left and right gear box halves (2791). Insert three 5X11mm ball bearings (4610) into each half, as shown.

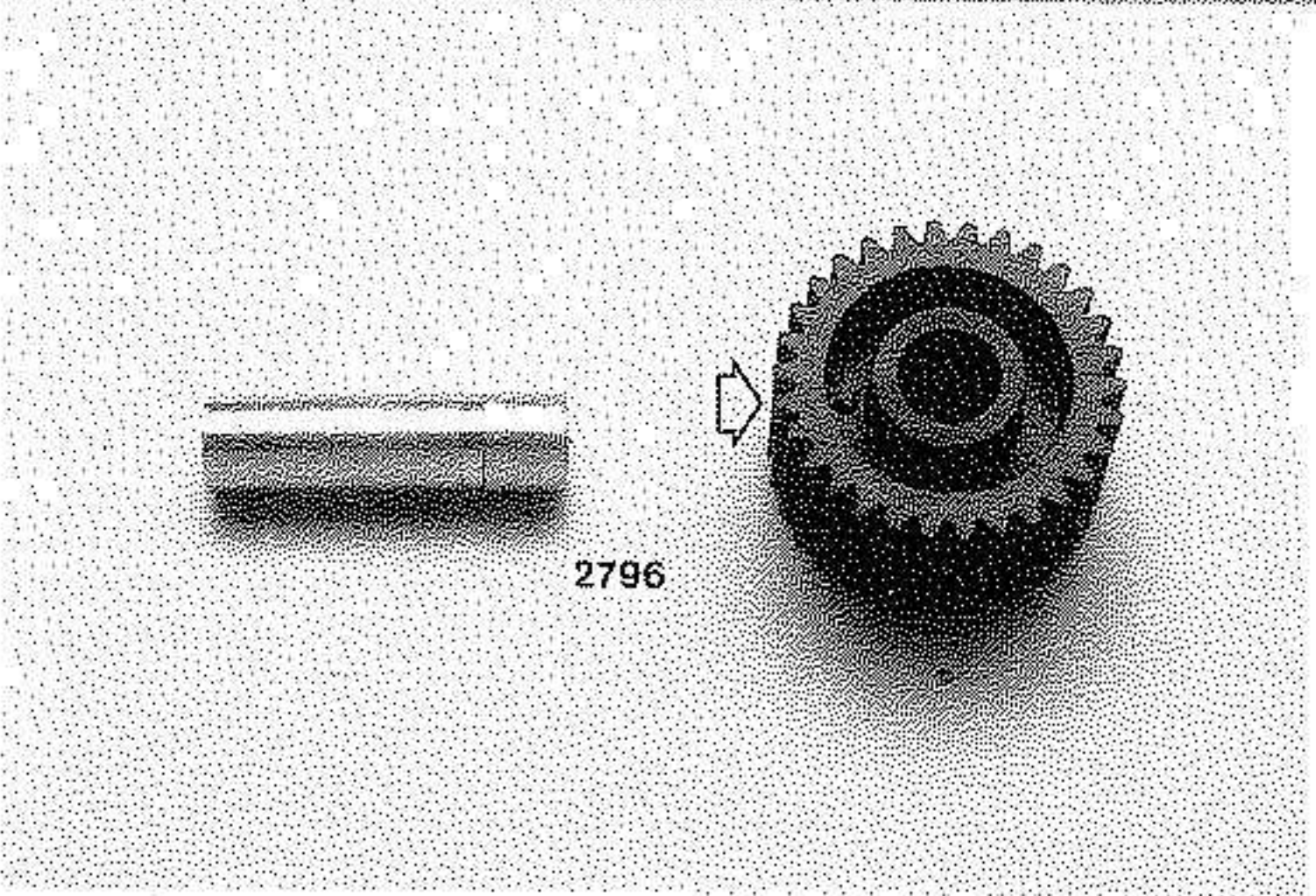

### STEP B-5

Locate the 30-tooth idler gear (2796) and the idler gear shaft (2796). Note that one face of the idler gear has been marked with a small dimple (arrow).

### STEP B-6

Insert the idler gear shaft, grooved end first, into the side of the gear marked with the dimple. Push it in until you feel the groove snap into the boss inside the gear. The gear will be centered on the shaft when the groove is snapped in properly.

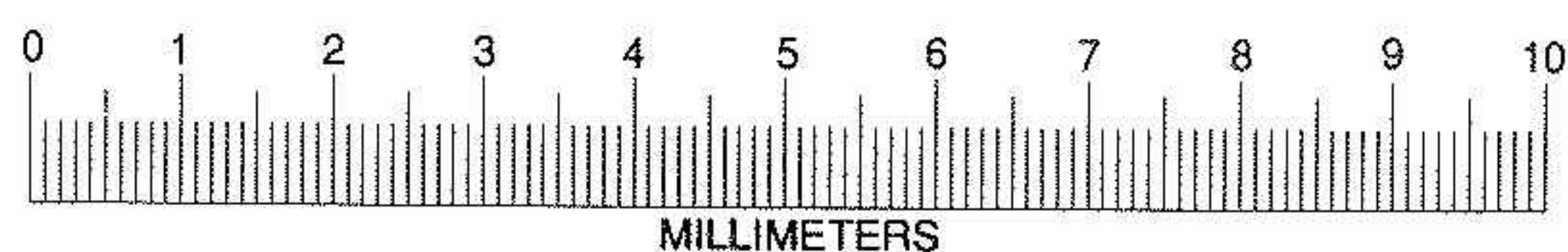
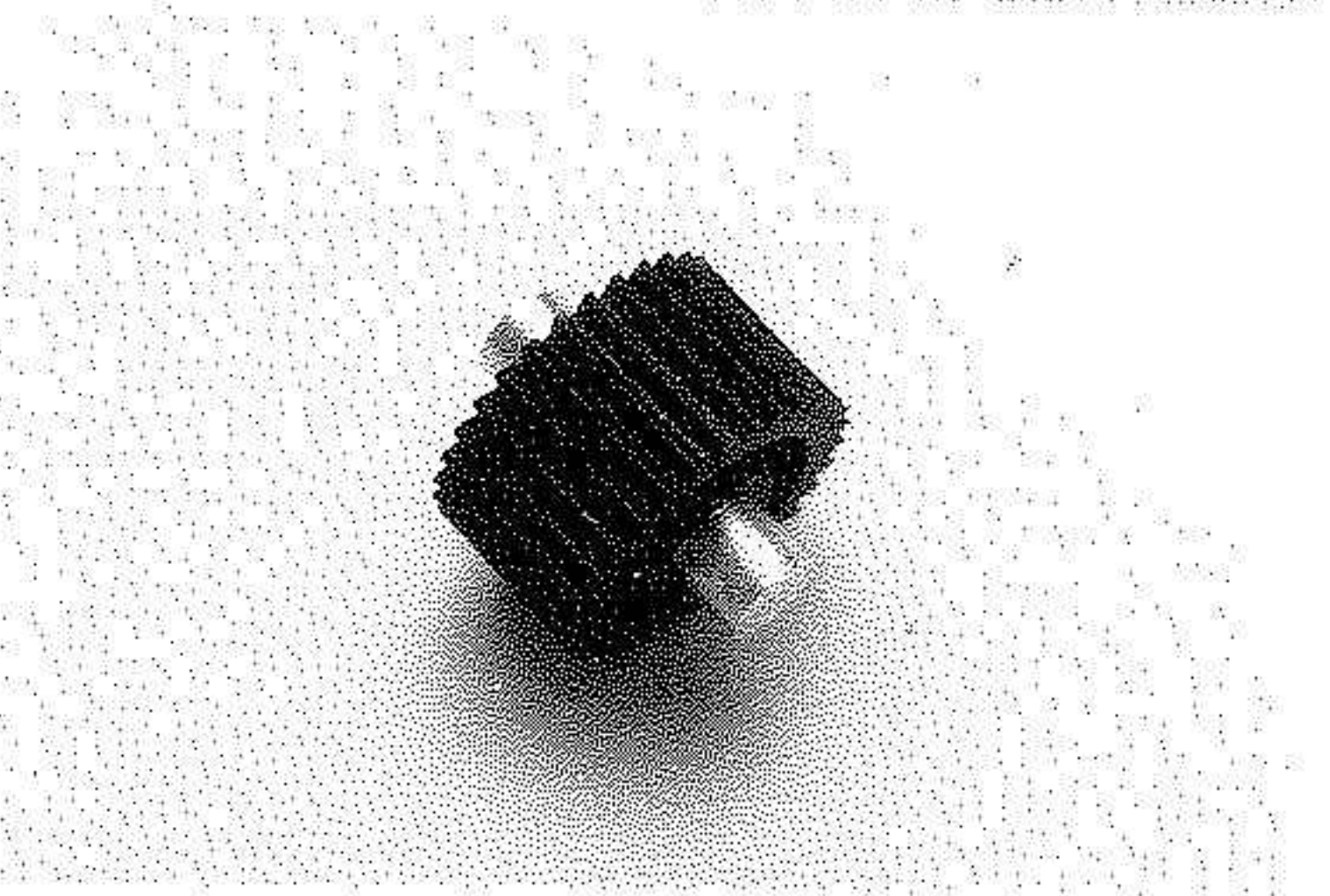

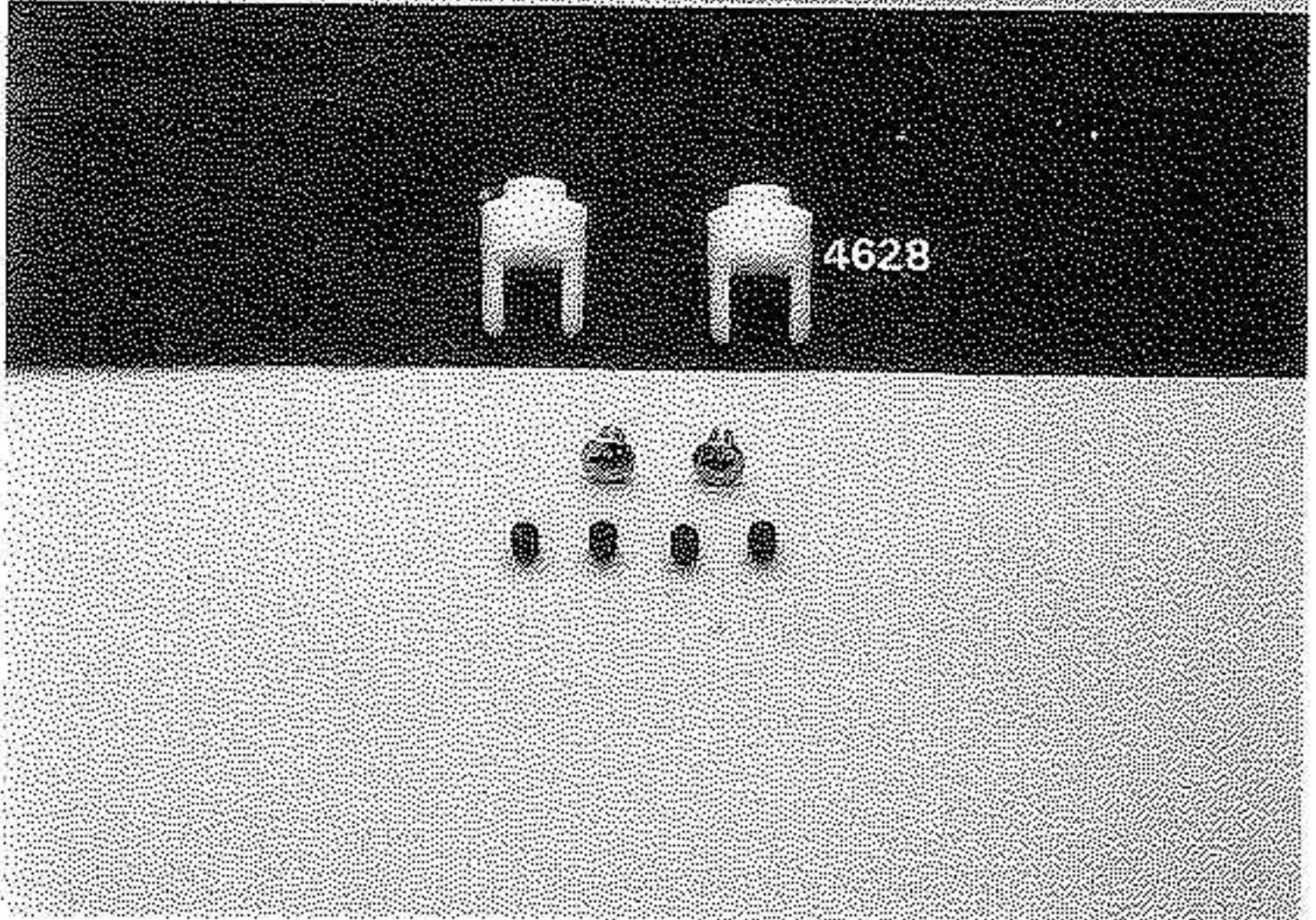
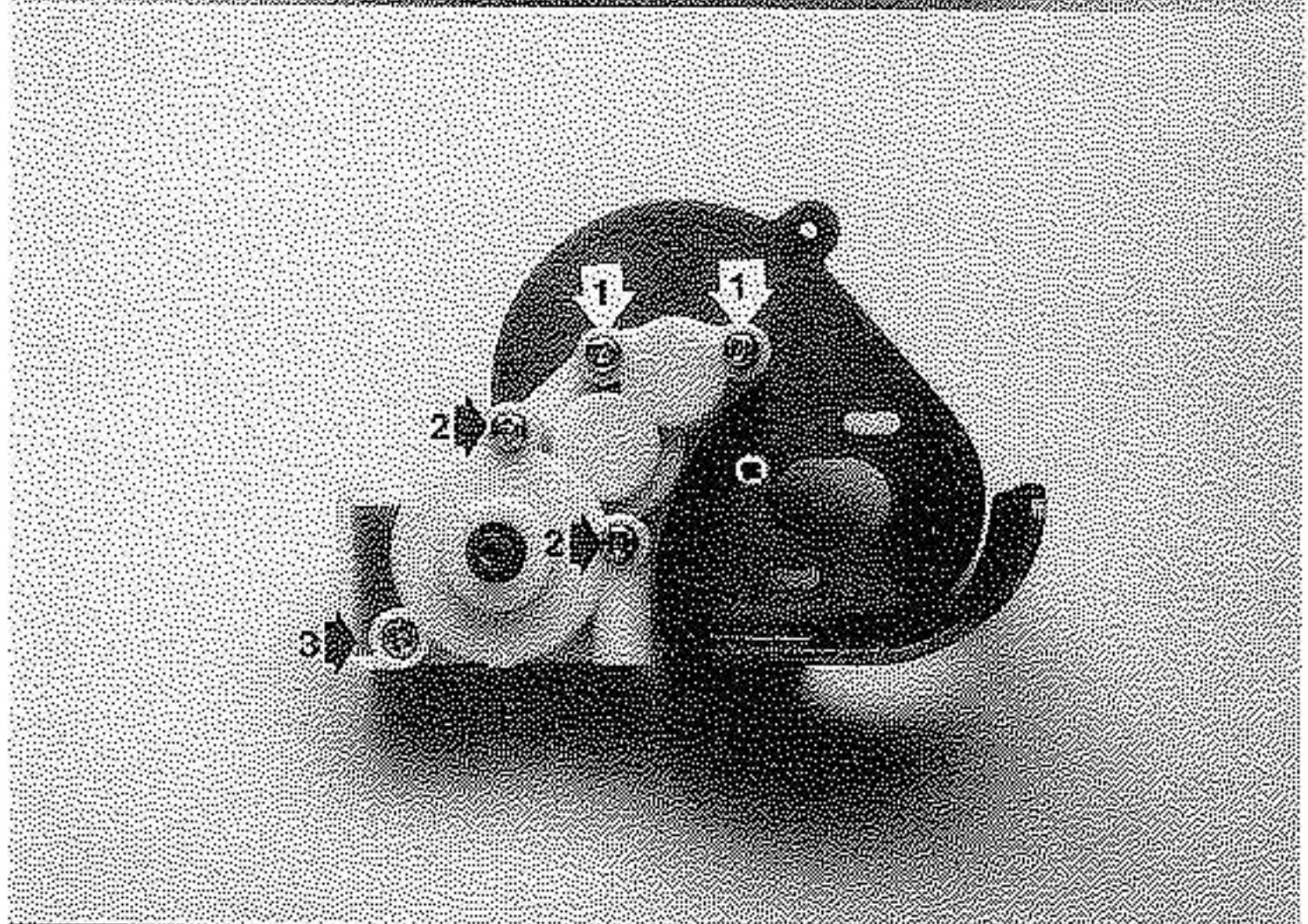
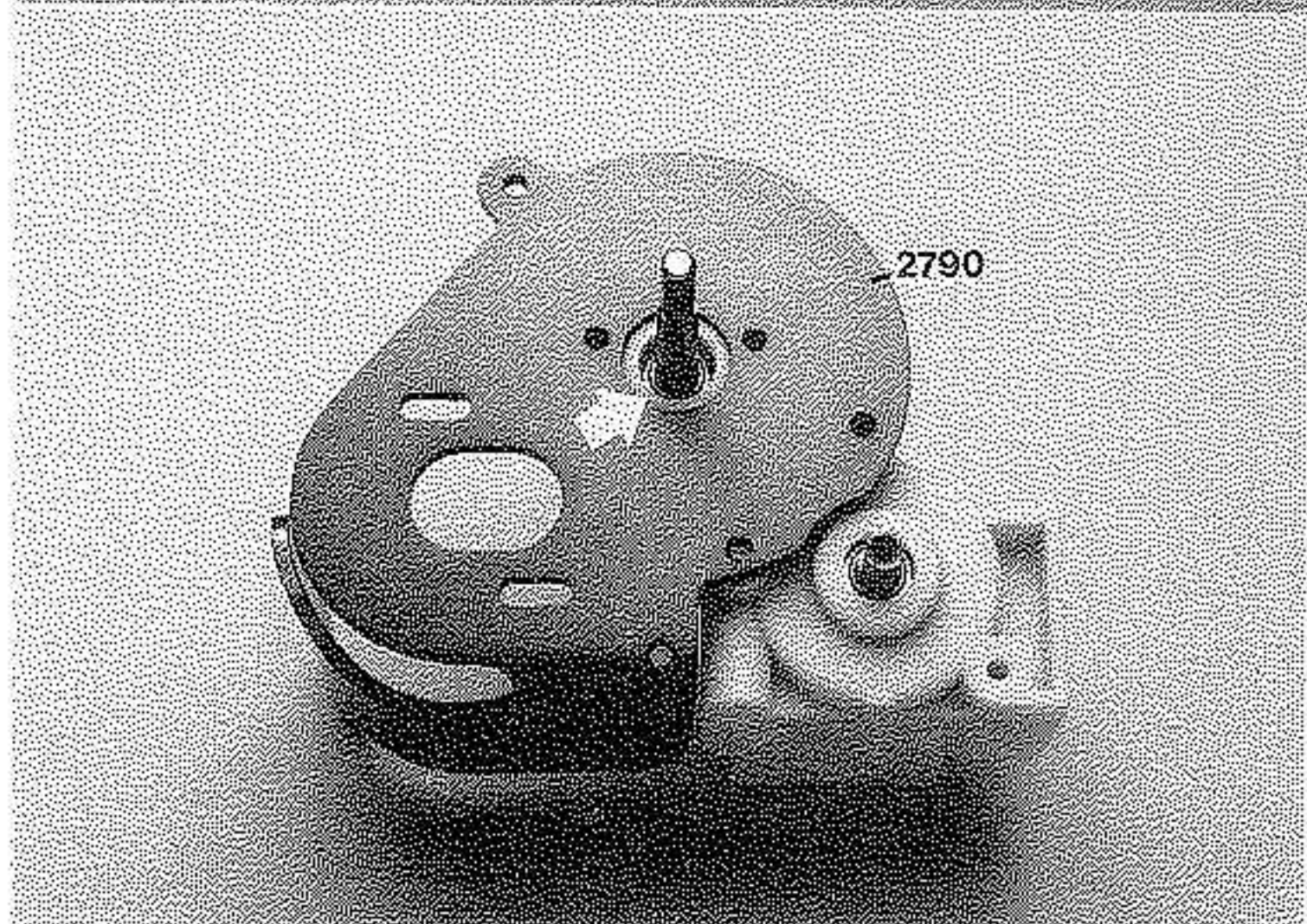
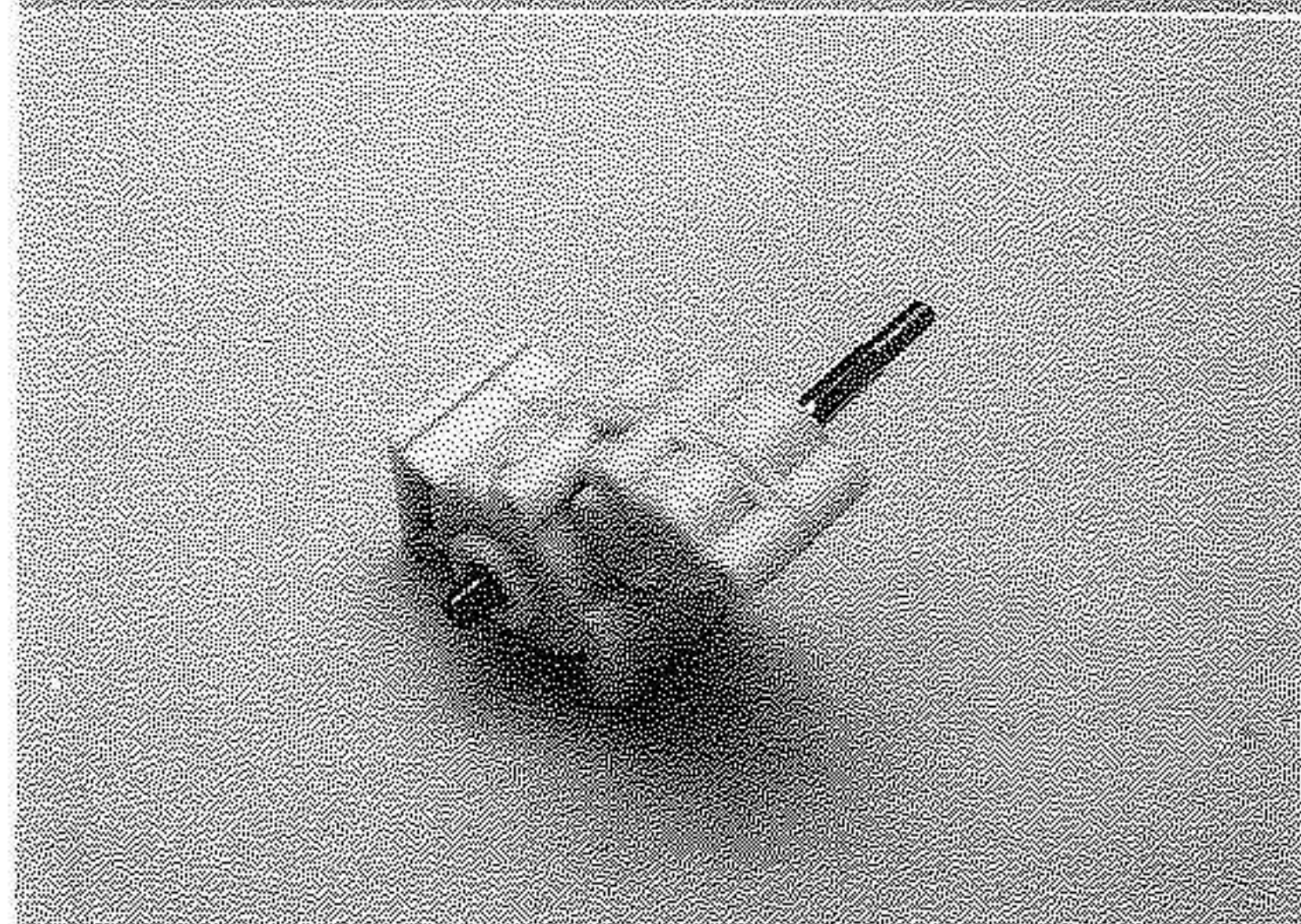
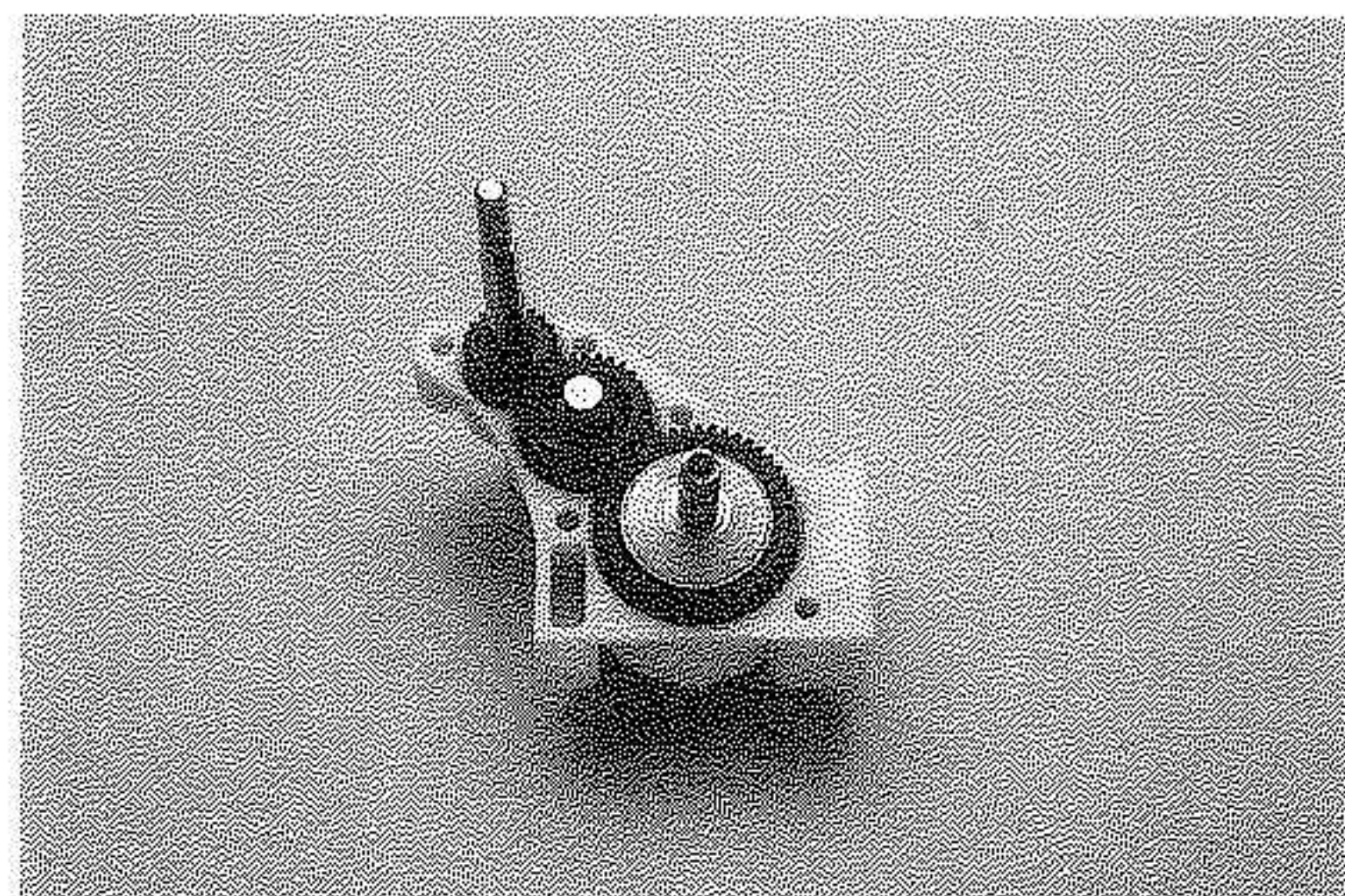

### STEP B-7

Locate the slipper shaft assembly, and insert it into the gearbox with the pinned end going into the left gearbox half. Now, Insert the idler gear assembly into the left gearbox half. Finally, locate your completed ball diff assembly and put it into the gearbox with the left output shaft (adjusting side) inserted into the left gearbox half.

### STEP B-8

Locate the right gearbox half. Carefully guide the gearbox half over the slipper, idler, and ball diff shafts, until it closes flush with the left gearbox half. Holding the gearbox case together tightly with your fingers, spin the slipper shaft to make sure that all of the gears are spinning freely, without binding. If there is a problem, check for dirt or mold flashing which may be hindering the gears. Remove it carefully with an X-acto knife.

### STEP B-9

Install the aluminum motor plate (2790) to the right side of the gear box. The center hole of the plate should snap over the boss around the slipper shaft output (arrow).

### Step B-10

Install a 3x25mm roundhead machine screw in each of the two locations indicated by the #1 arrows in the photo, and a 3x30mm roundhead machine screw into each of the locations indicated by the #2 arrows. Install a 3x20mm roundhead machine screw in the hole indicated by the single #3 arrow. **DO NOT USE A POWERED SCREWDRIVER FOR THE GEAR BOX SCREWS.** By using an electric screwdriver, you risk cross-threading or stripping the threads that are tapped into the aluminum plate. Use care when starting these screws.

### STEP B-11

Locate the two ball diff yokes (4628), two 3X5mm countersunk machine screws, and four 3mm grub screws.

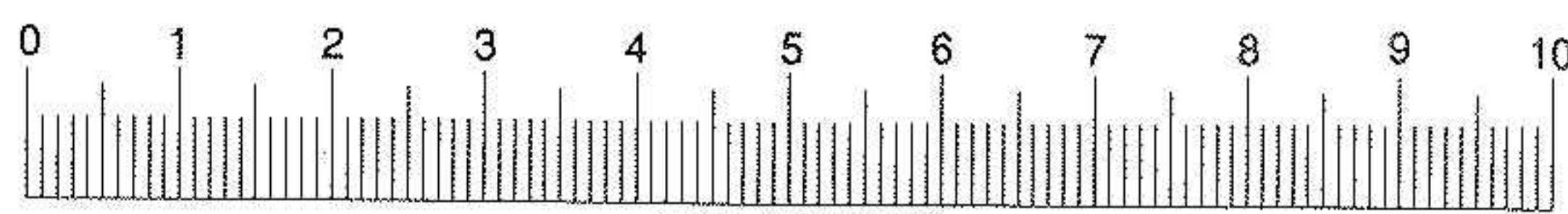

3X5mm COUNTERSUNK MACHINE SCREW

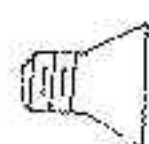

MILLIMETERS

3mm SET (GRUB) SCREW



3 x 20mm ROUNDHEAD MACHINE SCREW

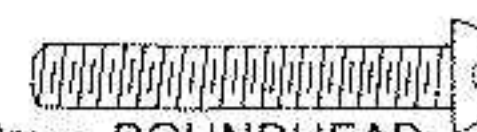

3X25mm ROUNDHEAD MACHINE SCREW

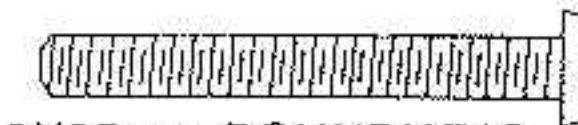

3 x 30mm ROUNDHEAD MACHINE SCREW

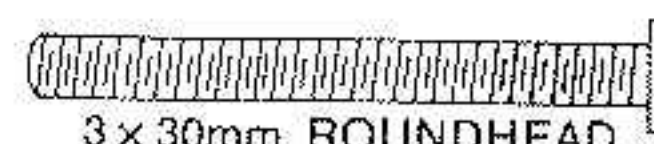

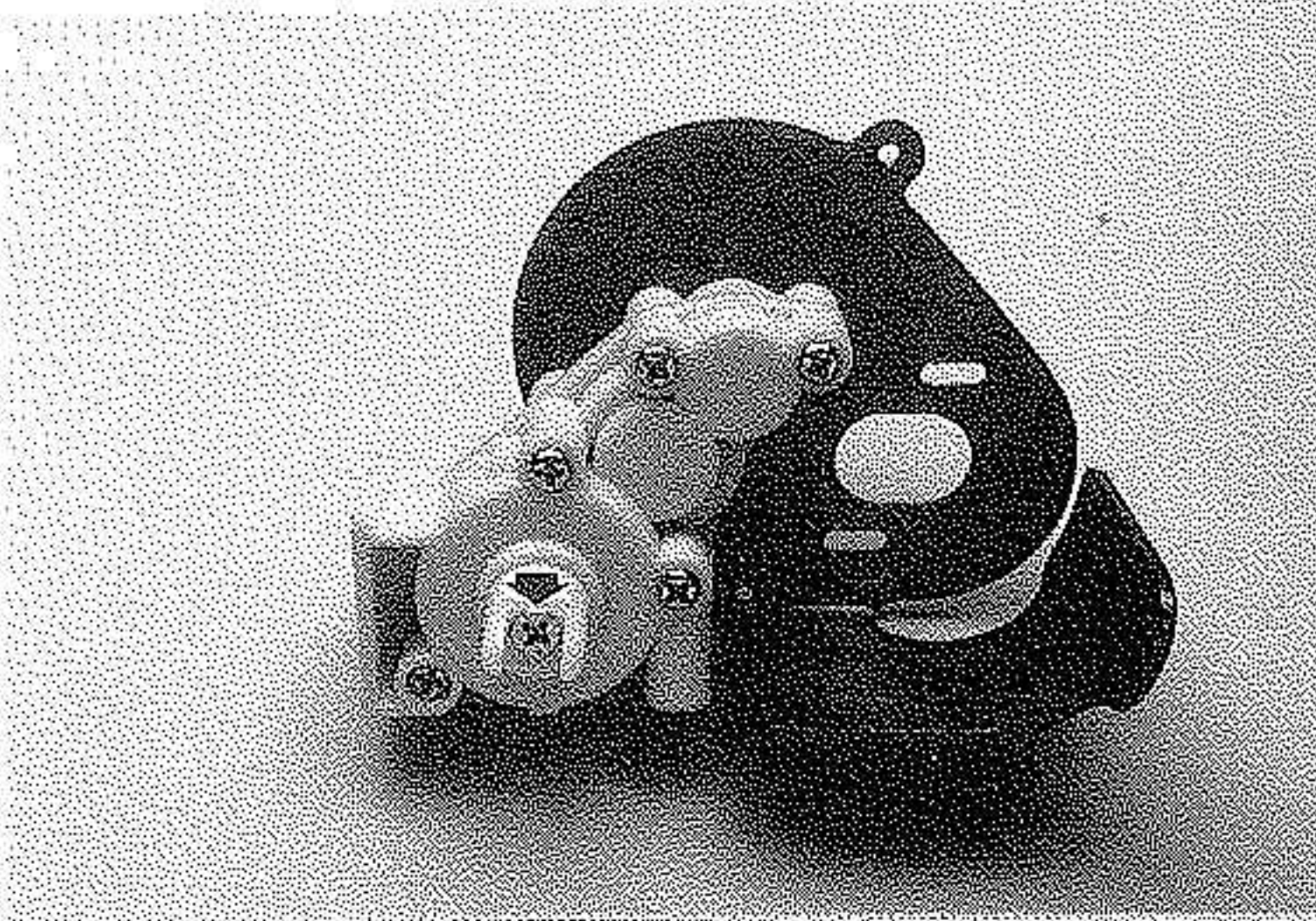

## STEP B-12

Press one of the yokes down completely onto one of the ball diff output shafts. Match the flat areas on the shaft with the flats inside the yoke. Secure it with a 3X5mm countersunk machine screw going through the center of the yoke. Repeat for the opposite side.

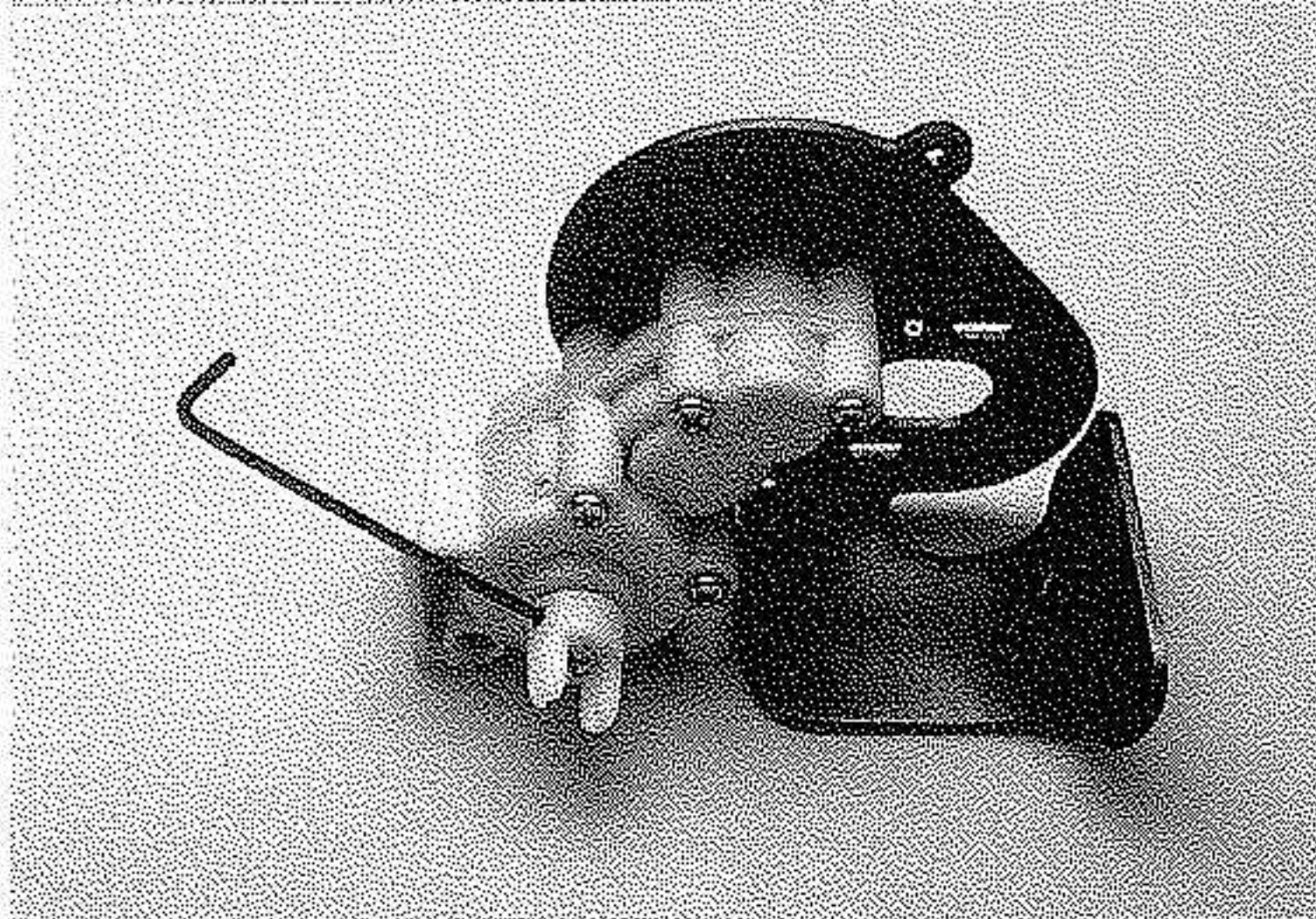

## STEP B-13

Into each yoke, tighten two 3mm grub screws against the flat sides of the ball diff output shafts.

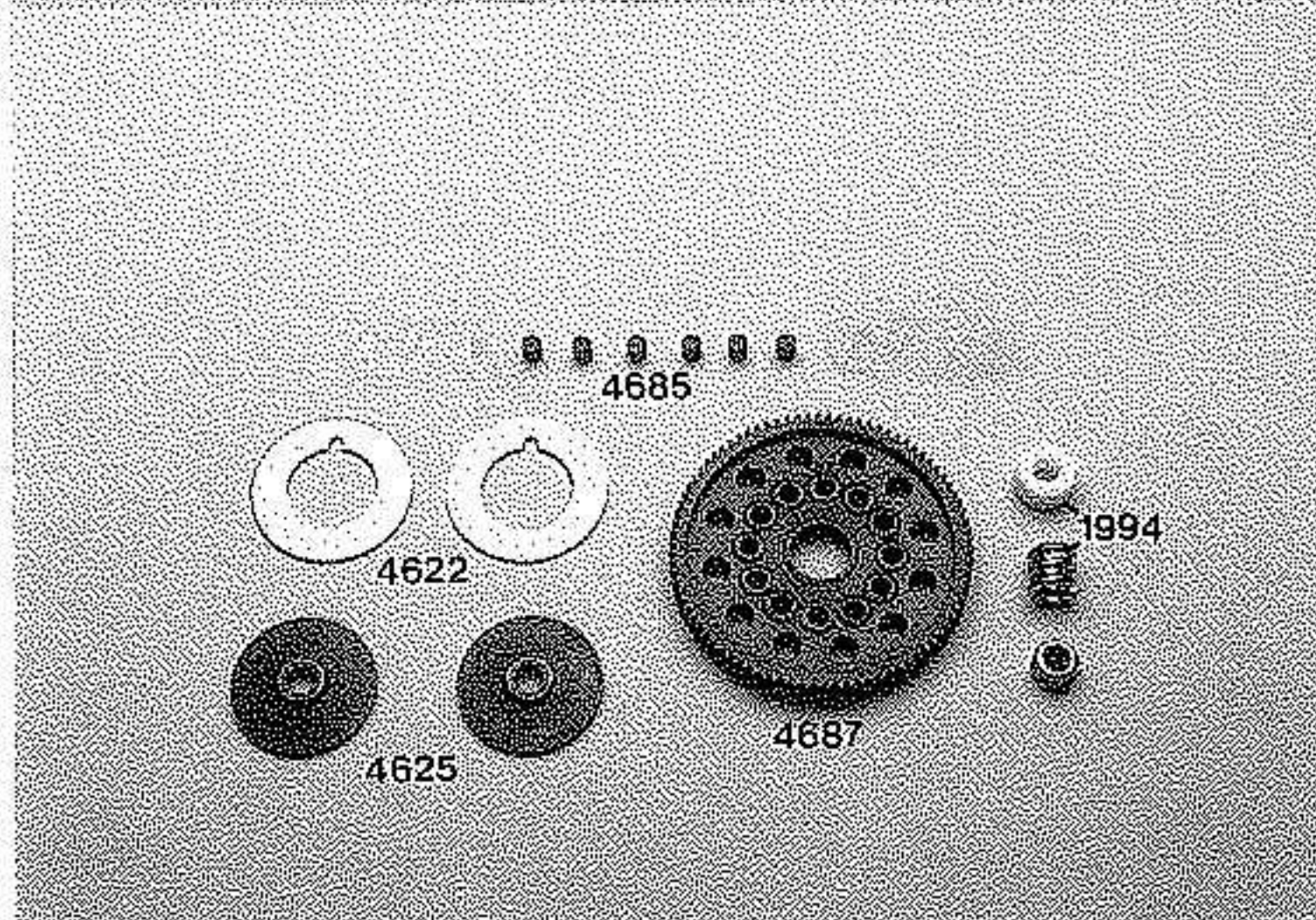

## SLIPPER ASSEMBLY

### STEP B-14

Locate the bag containing the two notched slip rings (4622), the two slipper pressure plates (4625), 6 slipper clutch friction pegs (4685), one teflon spur gear bushing (1994), one coil tension spring (1994), either the 87 or 81-tooth spur gear (4687, 4681), and one 4mm locknut. Refer to the section in the tuning guide about motors and gearing to determine which spur gear you want to use. If there is any machining oil on the metal parts, remove it now with motor spray or solvent.

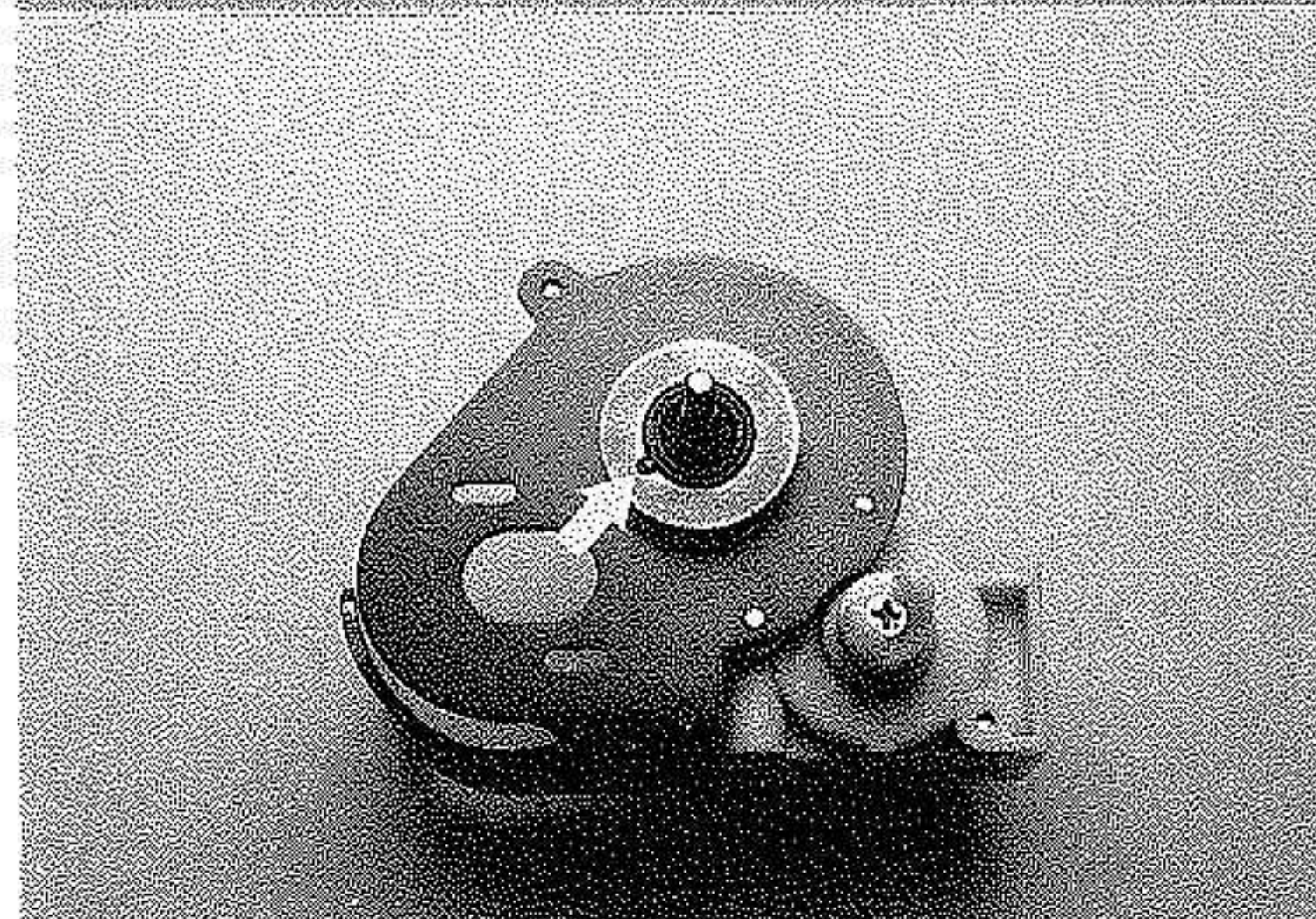

### STEP B-15

Slide one slipper pressure plate (4625) over the slipper shaft, making sure it bottoms against the shoulder on the shaft. Now, place a notched slip ring (4622) on top of the pressure plate, lining the notch up with the boss on the plate (arrow).

**RACER'S TIP:** Place a drop of very thin Super Glue between the pressure plate and the slip ring. This will make assembly and disassembly easier. Make sure that the glue spreads even and flat between the plate and the ring.

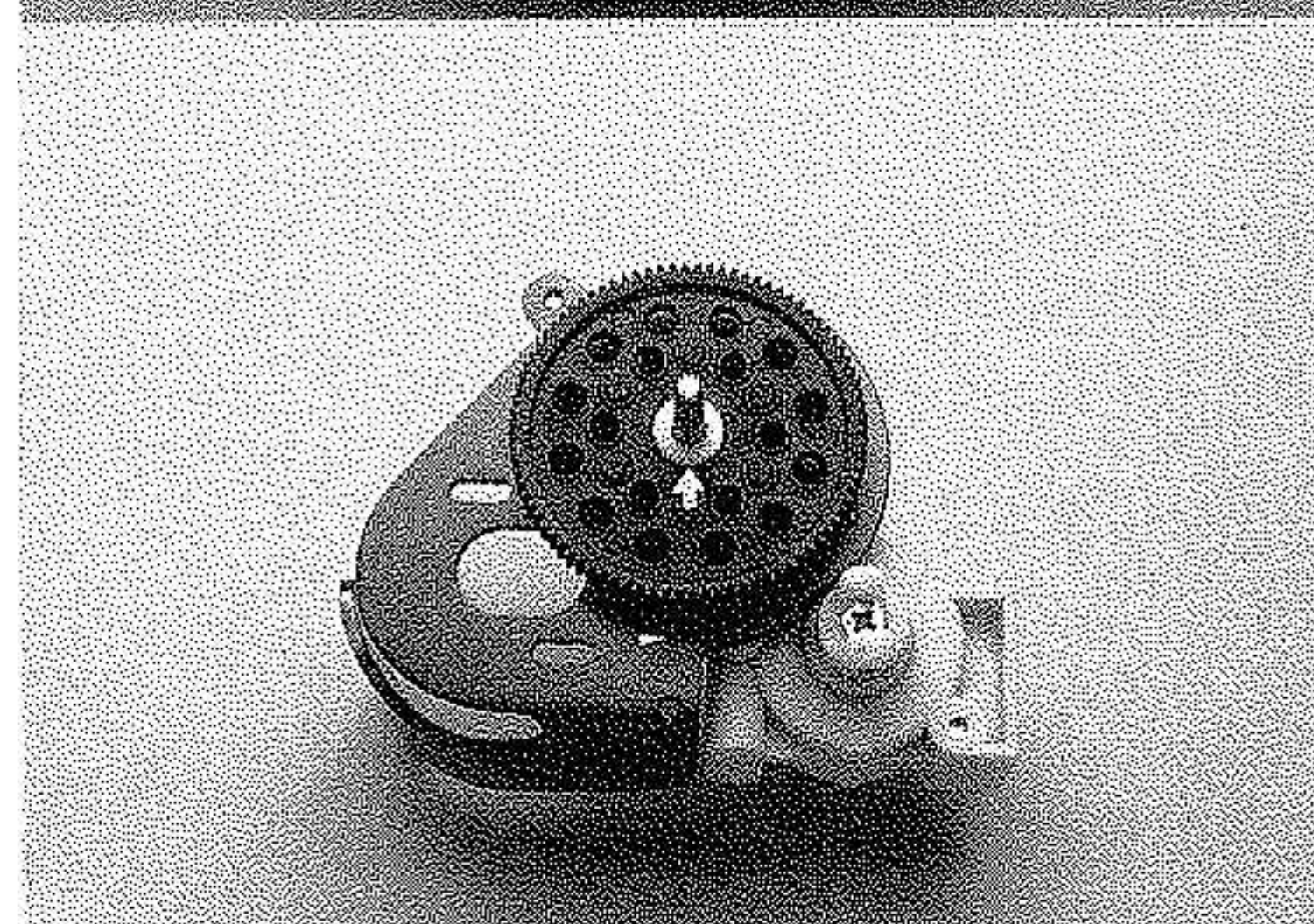

### STEP B-16

Push the teflon bushing (1994) onto the slipper shaft. Push it down until it stops against the pressure plate (arrow). Next, locate the spur gear and install it over the bushing. Now, insert the 6 slipper clutch friction pegs (4685) into the holes in the gear. Keep the transmission up on its side in order to keep the friction pegs from falling out.

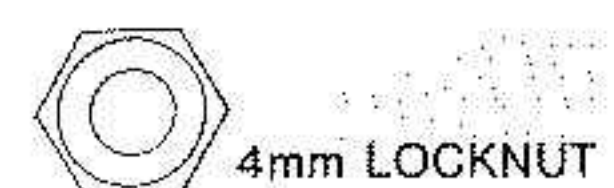
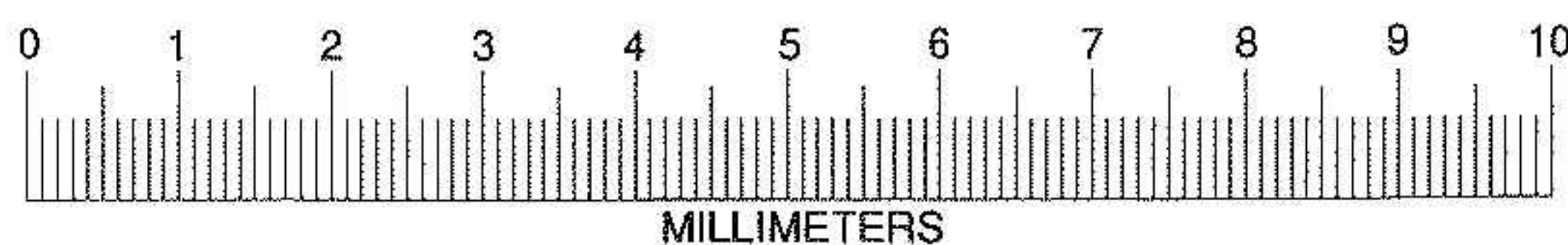

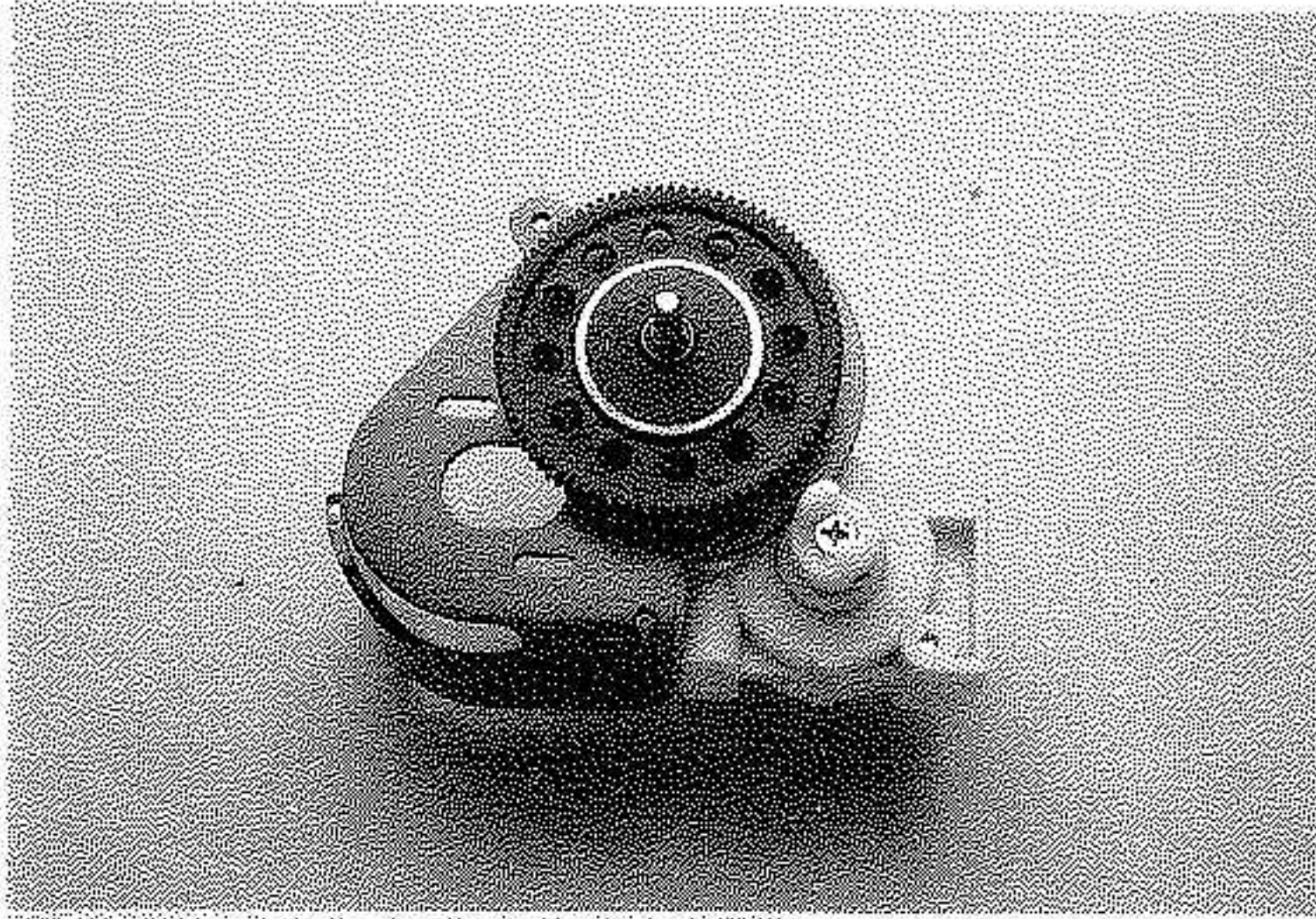

### STEP B-17

Place the remaining notched slip ring over the slipper shaft, followed by the other remaining pressure plate. It is a good idea to glue the slip ring and plate together here, as referenced in step B-15. If they are not glued, it is very difficult to get the ring centered and installed on the slipper.

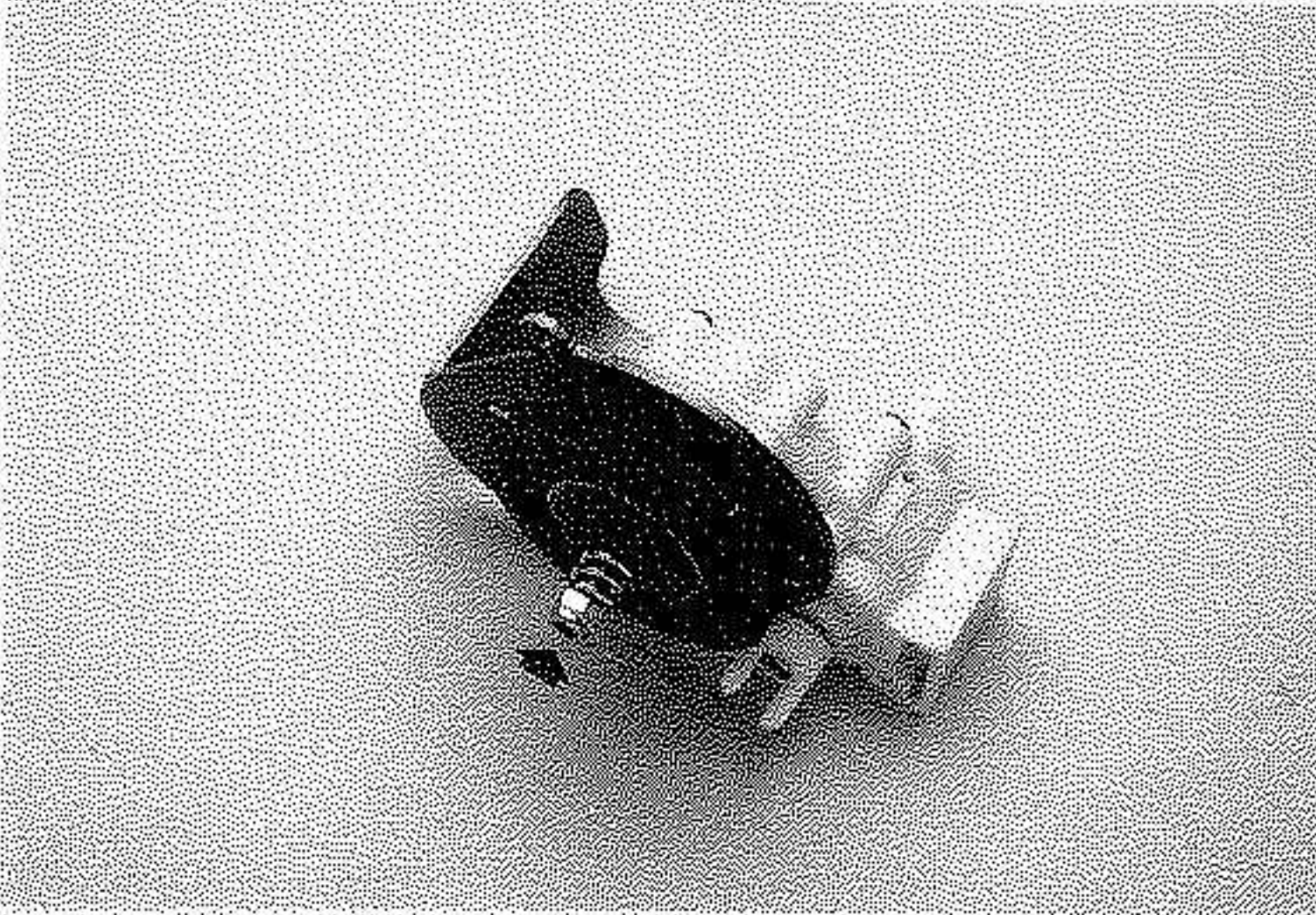

### STEP B-18

Install the coiled tension spring (1994) over the slipper shaft and secure it with the 4mm locknut. Tighten the locknut only enough to barely load the spring. Instructions for adjustment are in the back of this manual. The slipper adjustment cannot be made accurately until the car is fully assembled. Before continuing with the next steps, carefully inspect your transmission at this time to be sure all of the parts rotate freely.

NOTE: It is normal for the spur gear to slide back and forth on the pegs. As the pegs wear, this movement will become decrease. Although the gear may appear "wobbly", centrifugal force will automatically cause it to align against the pinion gear, once the transmission is spinning at normal operating RPMs.

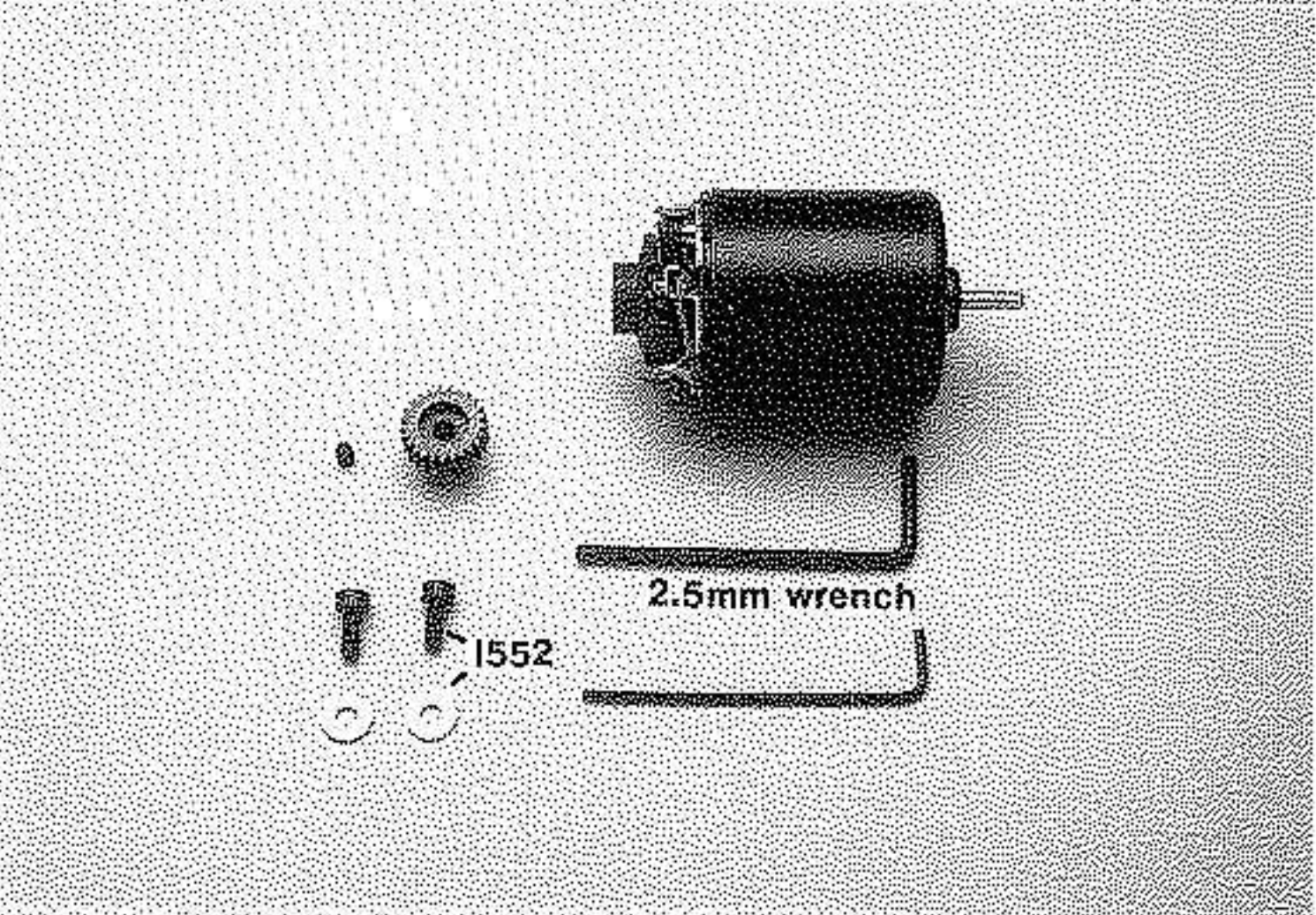

### STEP B-19

Locate your pinion gear and motor (not supplied in the kit), the 2.5mm grub screw wrench, two 3X8mm allen-head cap screws (1552) and two 3x8mm flat metal washers (1552).

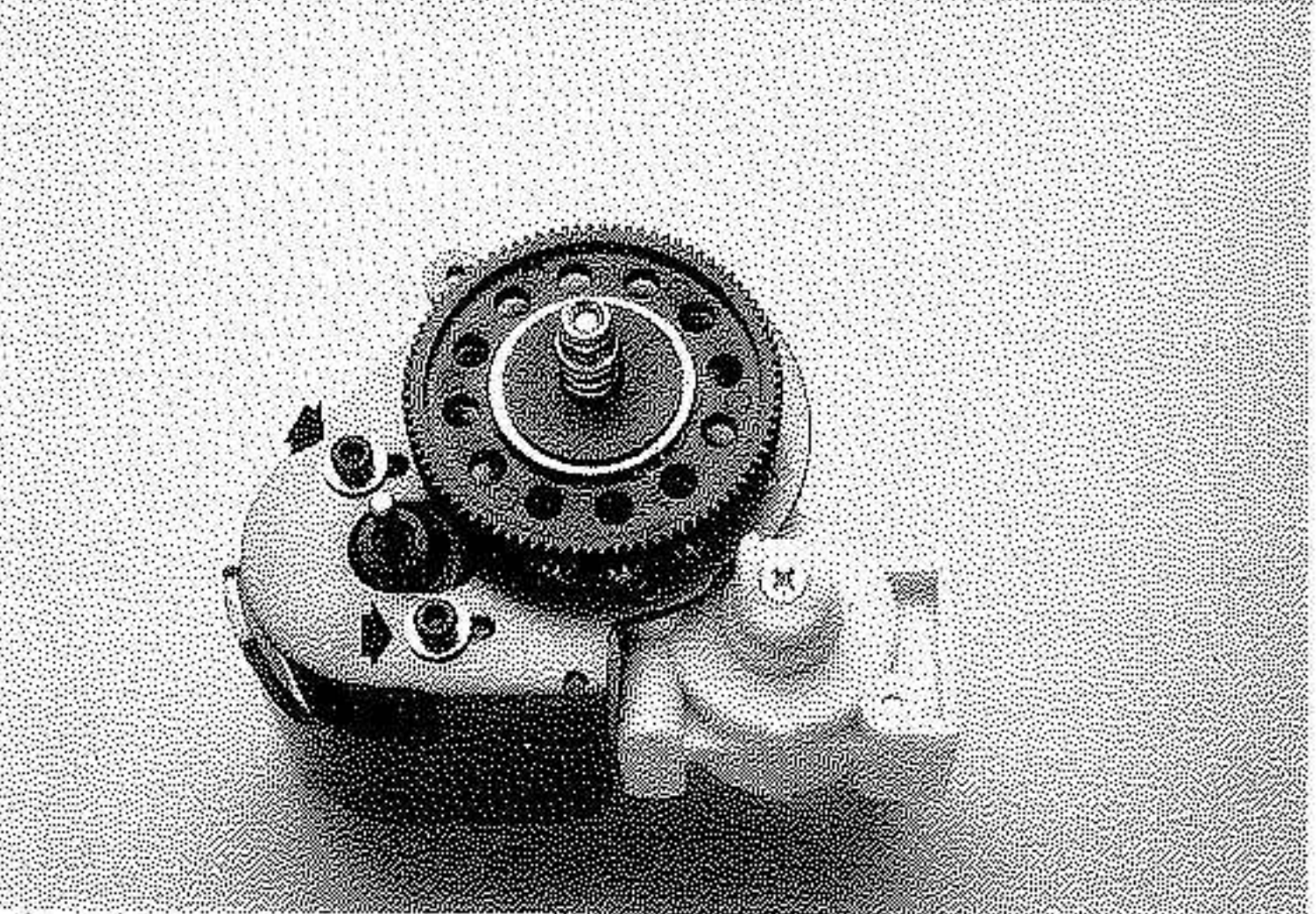

### STEP B-20

Attach the motor to the motor plate with the two 3X8mm cap screws and 3x8mm flat metal washers (arrows). Do not tighten the screws yet.

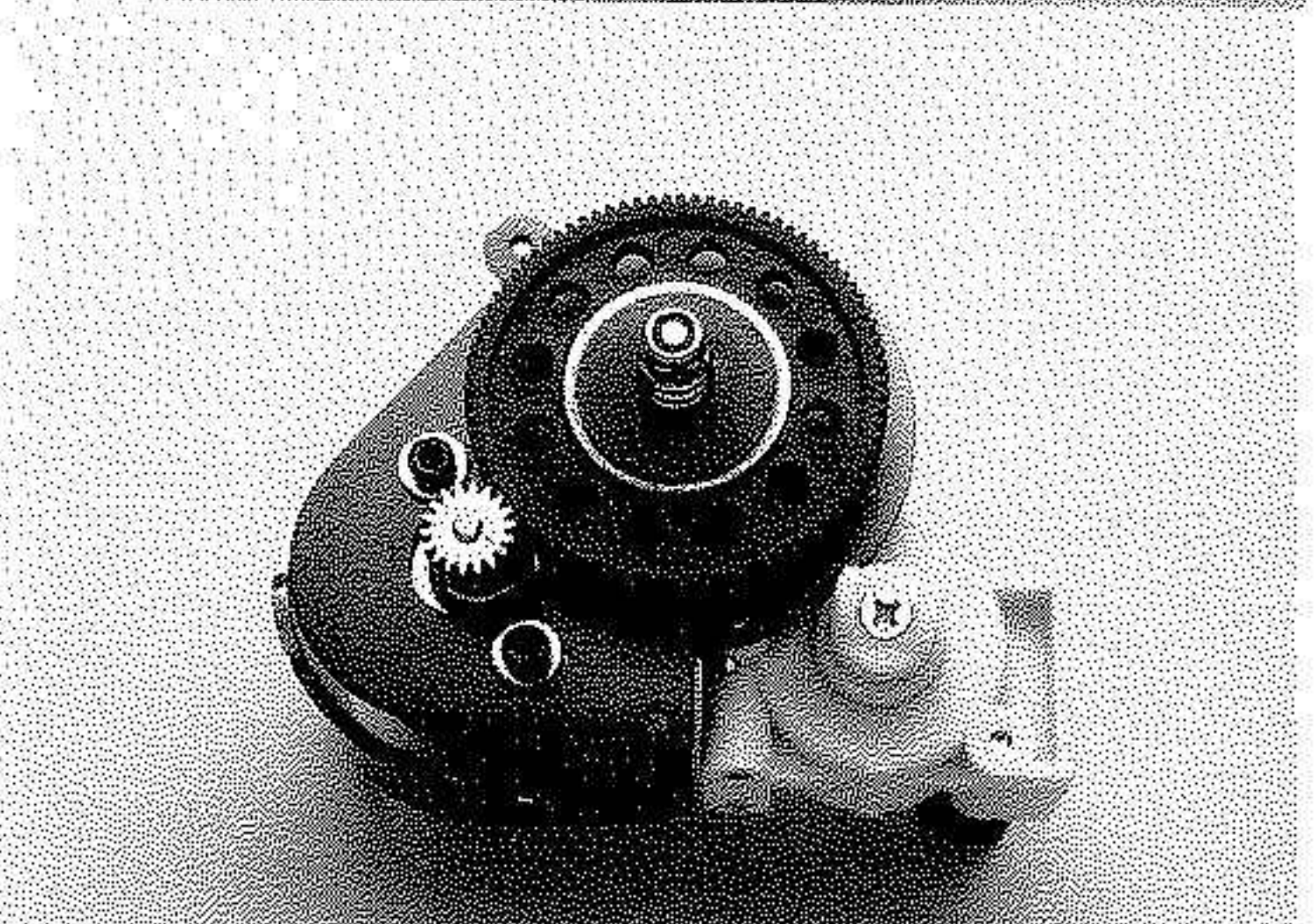

### STEP B-21

Push the pinion gear onto the motor shaft, as shown in the photo. Align the pinion gear with the spur gear and tighten the grub screw against the flat on the motor shaft. Adjust the gear mesh between the spur and pinion gears until there is only the slightest amount of play between the gears. Now, tighten the two motor screws.

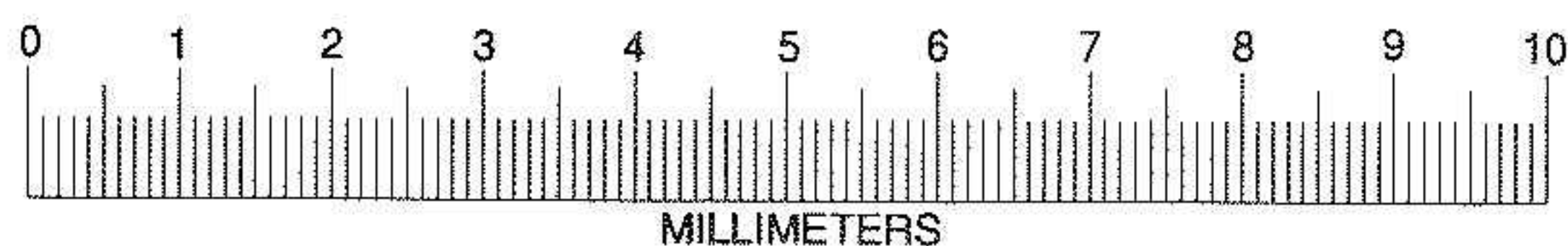

## BAG C: REAR SUSPENSION AND DRIVELINE STEP C-1

Locate the two 38mm turnbuckles (2741), four long rod ends (1942), and four hollow ball connectors (1942). Note that there are both left and right hand threads on the turnbuckles. The side of the turnbuckle nut which has the slight cone shape (arrow) denotes the reverse, left-hand threads. Screw the rod ends on equal numbers of turns so that they have a center-to-center distance of 59mm (as a starting point-you will be fine tuning the alignment later). Snap the metal hollow ball connectors into the rod ends.

**RACER'S TIP:** Put all of the turnbuckles on your car with the cone ends pointing the same direction (to denote left-hand threads). This will make it easier to remember which direction to turn your turnbuckles.

### STEP C-2

Locate the transmission bulkhead (1992). Slide a 3 X 15mm washerhead machine screw through one end of the turnbuckle followed by a 3 X 6.5 X 2.5mm aluminum spacer. Now insert the screw through the inside bottom hole of the bulkhead. Repeat for the opposite side. Do not use an electric screwdriver for this step.

**RACER'S TIP:** Refer to the tuning guide for more detailed information on how the different mounting holes can affect your truck's handling.

### STEP C-3

Locate the two internal-splined half shafts (1651), two metal U-joint balls (1651), and the U-joint assembly wrench (1648).

### STEP C-4

Begin by inserting one of the pins of the metal U-joint ball into the internal-splined half shaft. Assembling the drive shafts is somewhat difficult. Don't be discouraged if it takes several tries to get them to go together. You can do it!

### STEP C-5

Use the wrench, as shown, to seat the opposite pin into the half shaft. In order to spread both of the half shaft tines while pushing the pin into the half shaft, try to exert force down and to the left, as viewed in the photo.

**RACER'S TIP:** It is important that the metal U-joint pins turn freely inside the holes of the yoke sides. This reduces wear and friction, thus increasing the life of the yokes. Place a tiny drop of oil where the metal U-joint ball pins insert into the nylon yokes. If necessary, use a #44 (.086) drill bit to slightly enlarge the holes in the yoke. Perform this task carefully, by hand, and do not use any size other than the #44 drill bit.

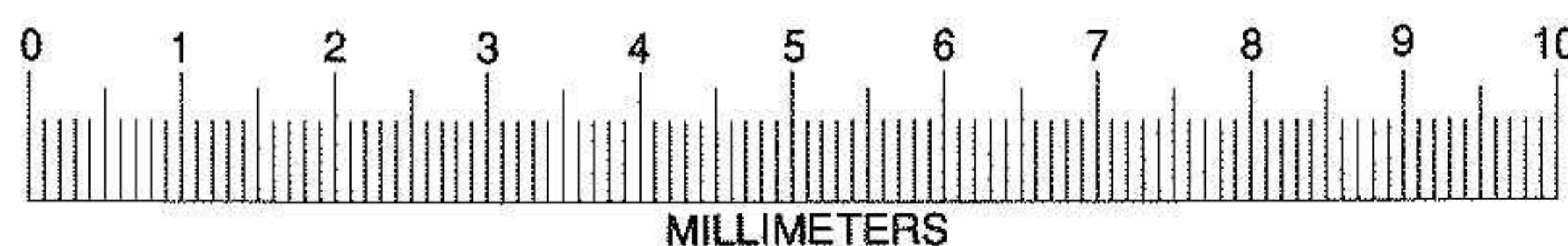
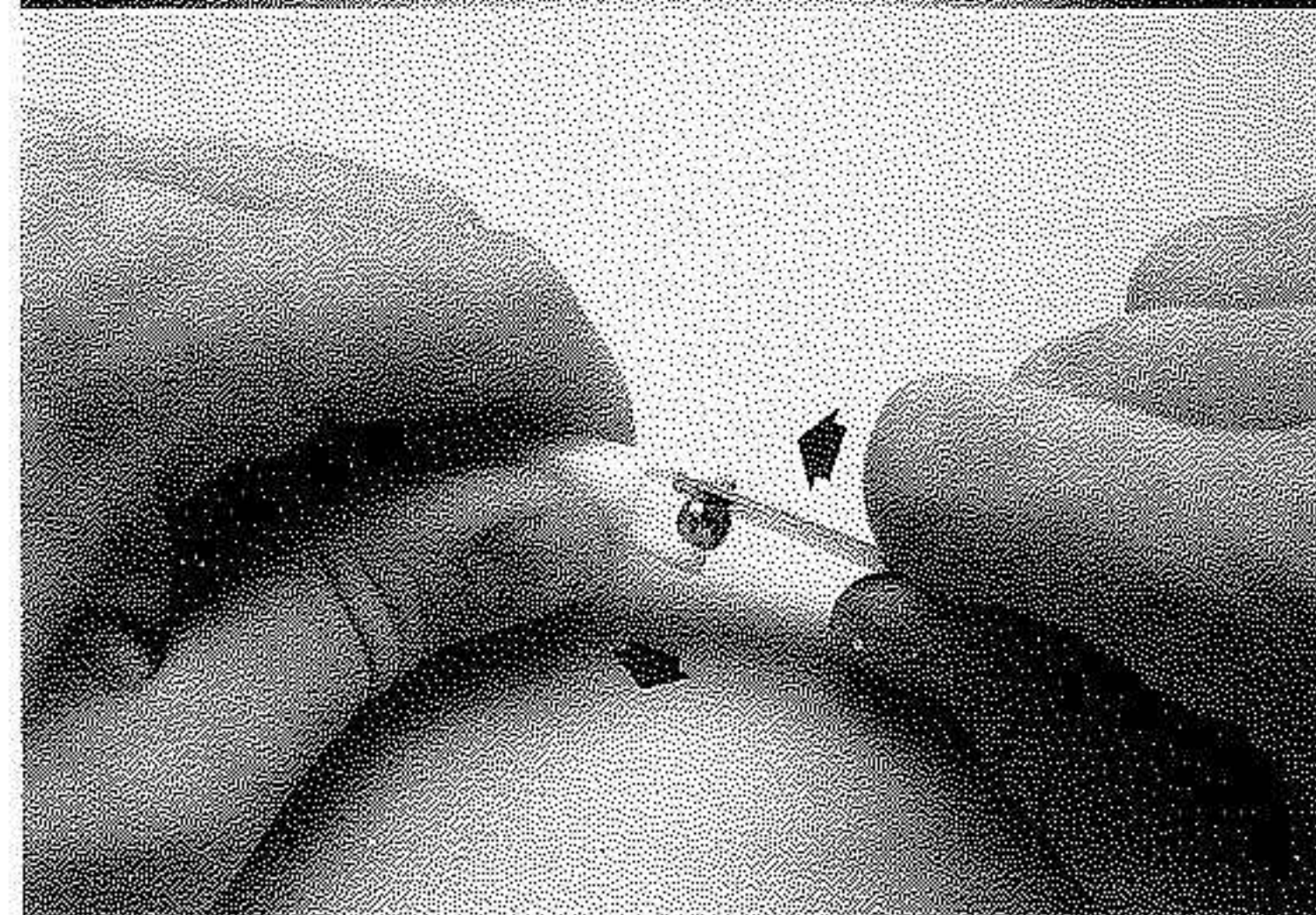
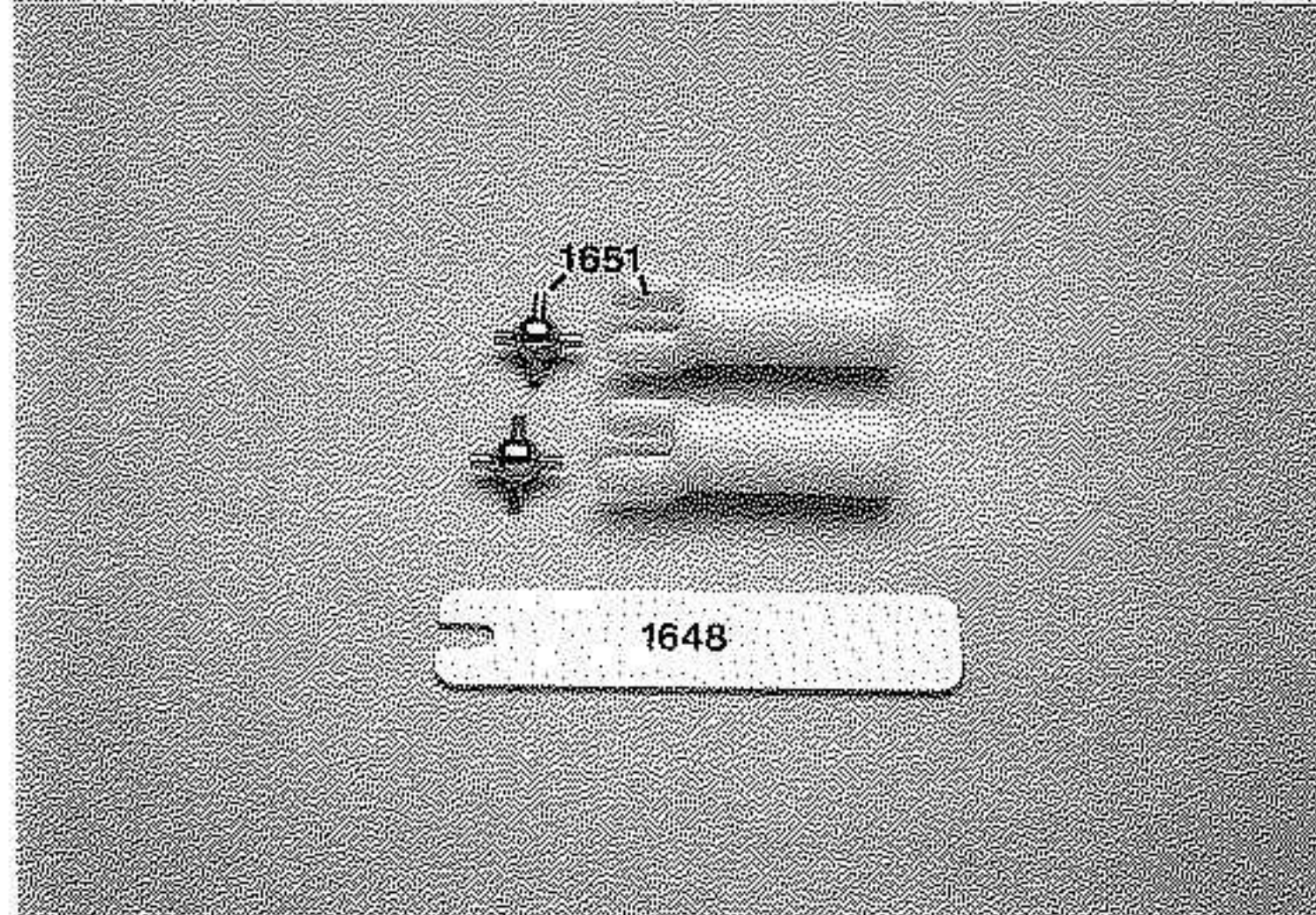
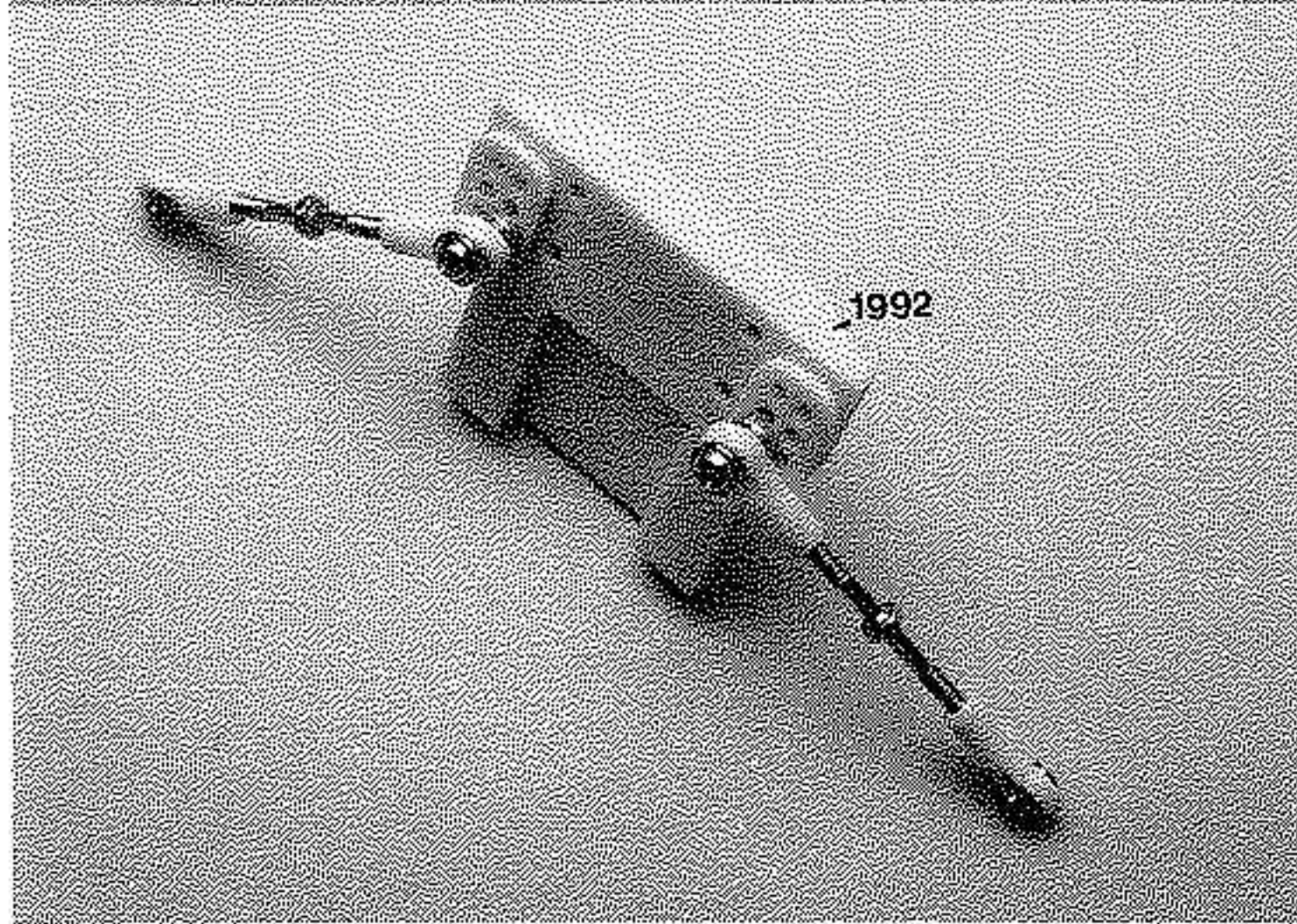
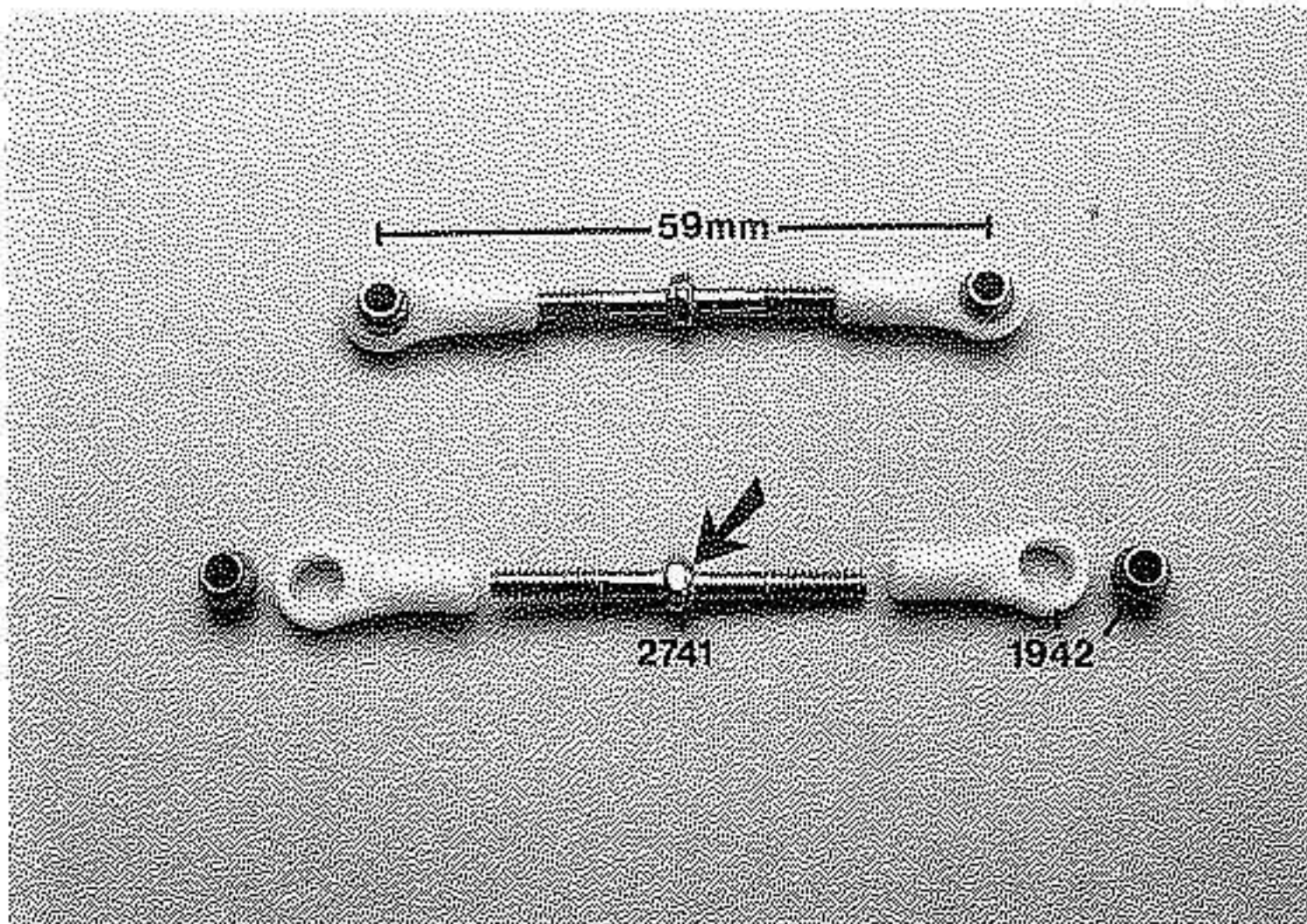

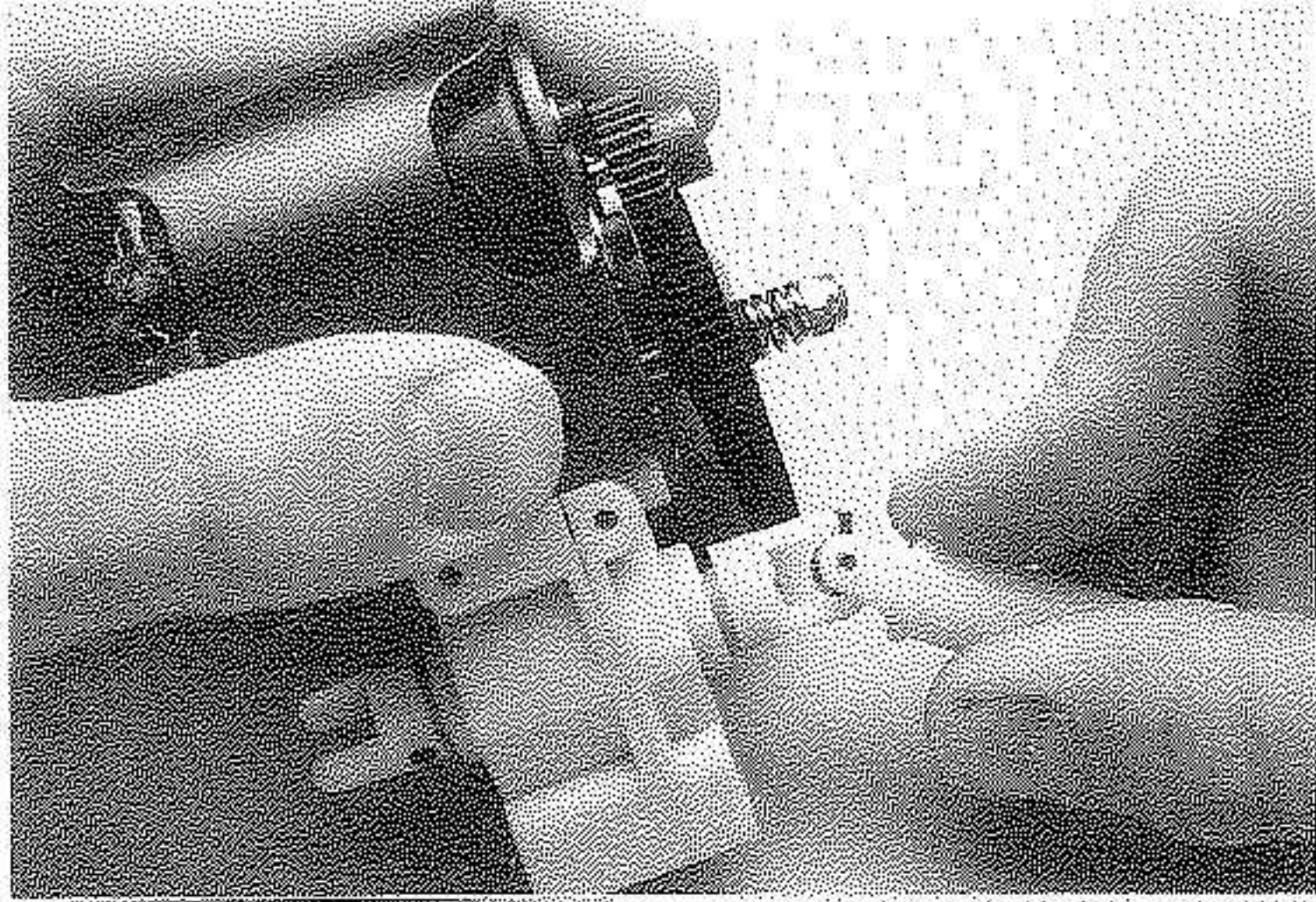

### STEP C-6

Push one of the remaining metal U-joint pins into one of the sides of the ball differential yoke.

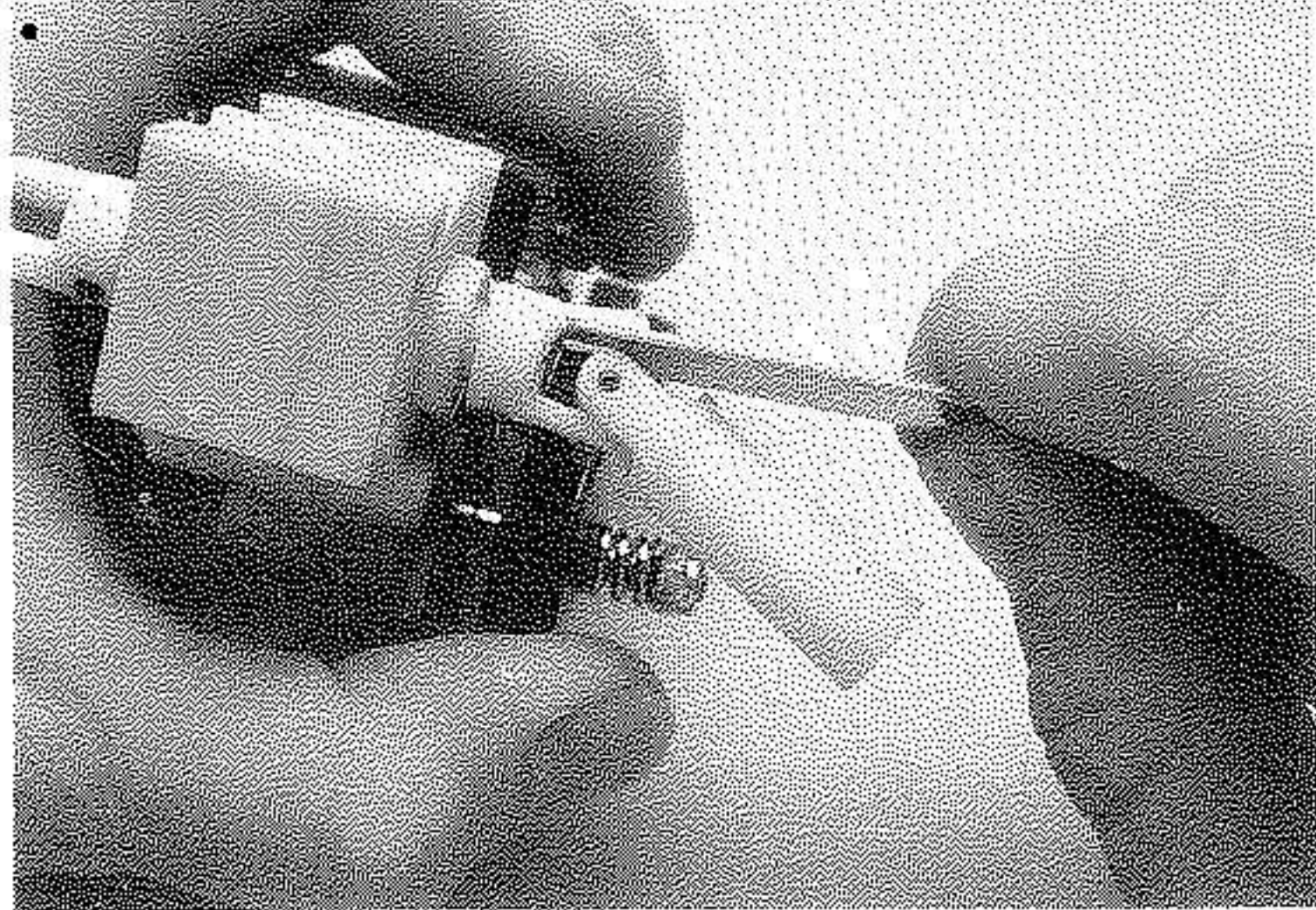

### STEP C-7

Use the U-joint assembly wrench to seat the remaining pin into the ball differential yoke. Again, try to spread both of the sides on the ball differential yoke, while pushing the pin into the hole. Repeat for the other side.

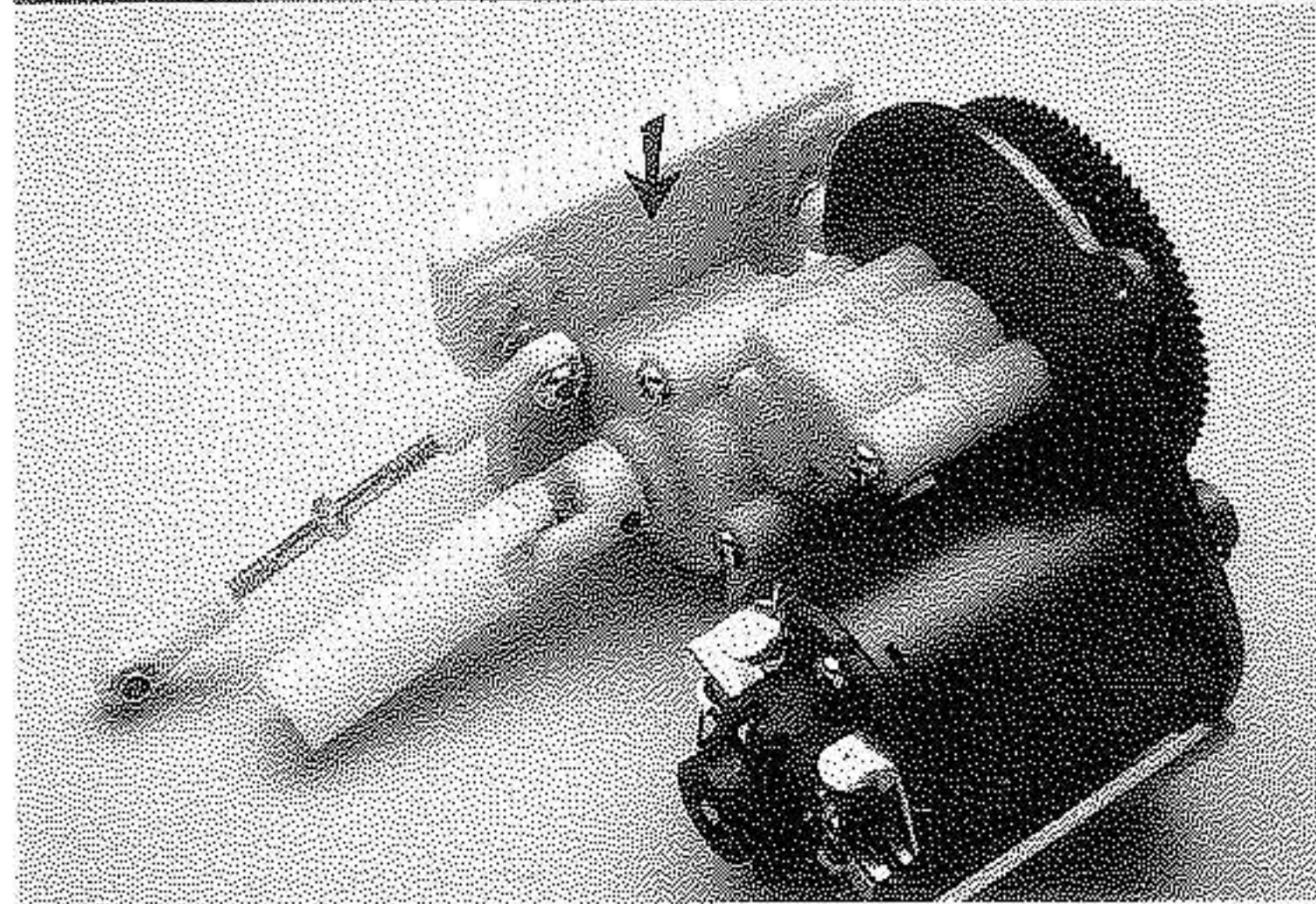

### STEP C-8

Slide the bulkhead onto the front of the transmission until it locks into place. The fit between the bulkhead and the transmission will be extremely tight.

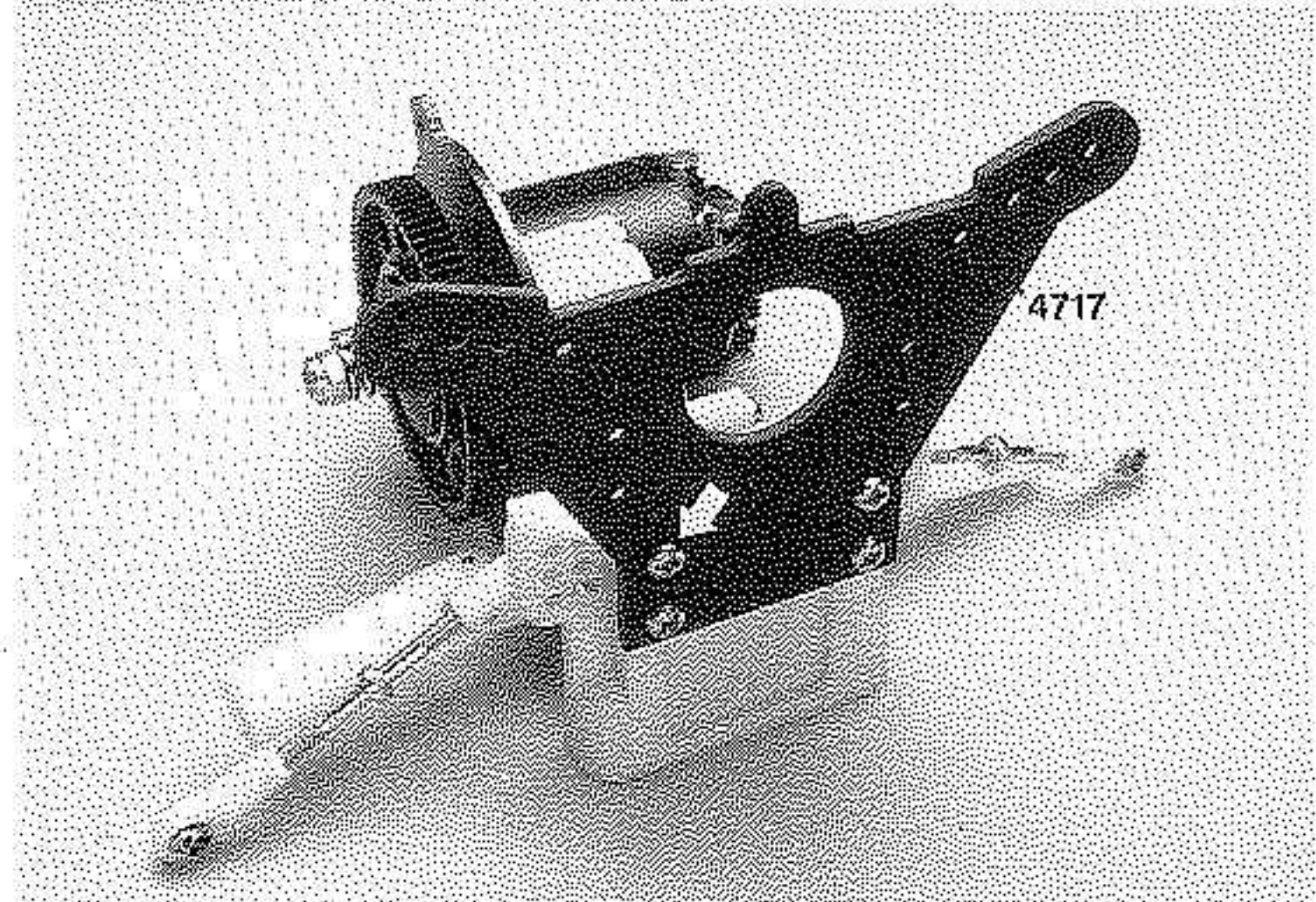

### STEP C-9

Fasten the rear shock tower (4717) to the bulkhead with four 3X10mm roundhead self-tapping screws.

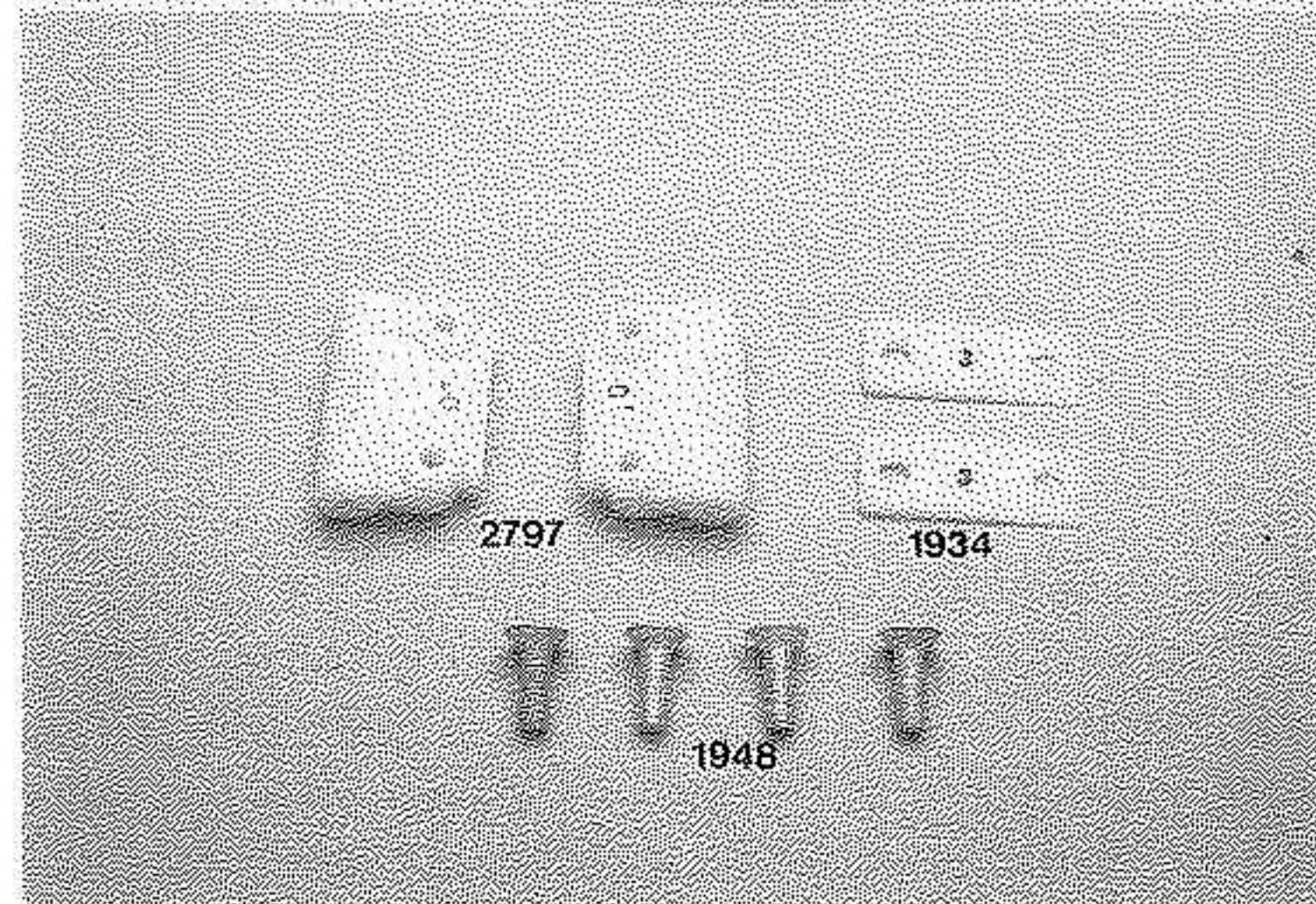

### STEP C-10

Locate the two zero-degree rear suspension arm mounts (2797), four 4X12mm aluminum countersunk machine screws, and the two, three-degree caster wedges (1934). There are two sets of rear suspension arm mounts included in your kit. One set is marked on the top with a plus and a minus, and will add or subtract one degree of toe-in from the rear suspension. The other set is marked with a zero on the top surface and when installed, has no affect on the toe-in. The tuning guide in the back of this manual explains the advantages of each set. For now, use the zero-degree mounts. There are also two pairs of caster wedges included in your kit, labeled 1.5 and 3.0. Usage for the 1.5-degree wedges is also described in the tuning guide.



3X10mm ROUNDHEAD SELF-TAPPING SCREW

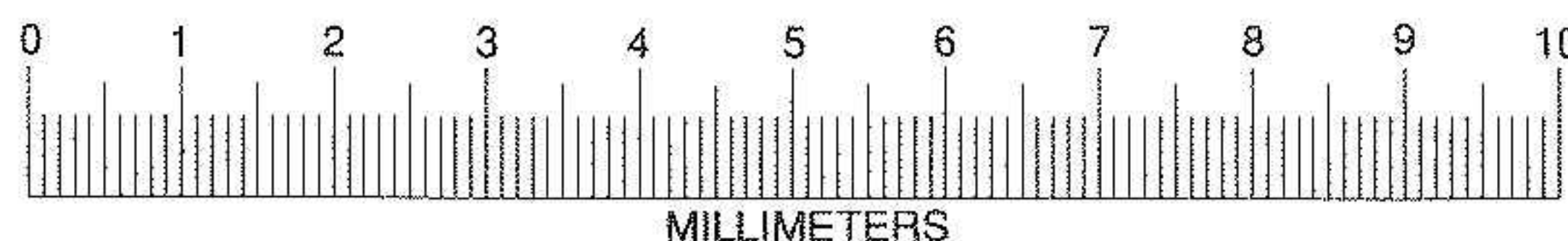

MILLIMETERS

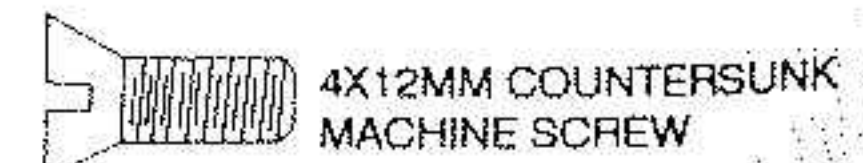

4X12MM COUNTERSUNK MACHINE SCREW



### STEP C-11

Position one of the 3-degree caster wedges underneath one of the rear suspension arm mounts, so that the thicker part of the wedge will be closest to the front of the car (arrow). Fasten this assembly to the chassis with two 4x12mm countersunk machine screws. Use the first and second large holes in the chassis when counting from the rear. Repeat for the opposite side.

**RACER'S TIP:** The aluminum screws are used because of their substantial weight savings, however, they require special handling. When tightening the screws, be sure to use only a #2 Phillips screwdriver which is in good condition. Tighten these screws firmly, but do not over-tighten. This will prevent damage to the head of the screw. Before removing these screws, dig all of the dirt out of the screw head with a sharp object in order to ensure that the screwdriver has a good fit.

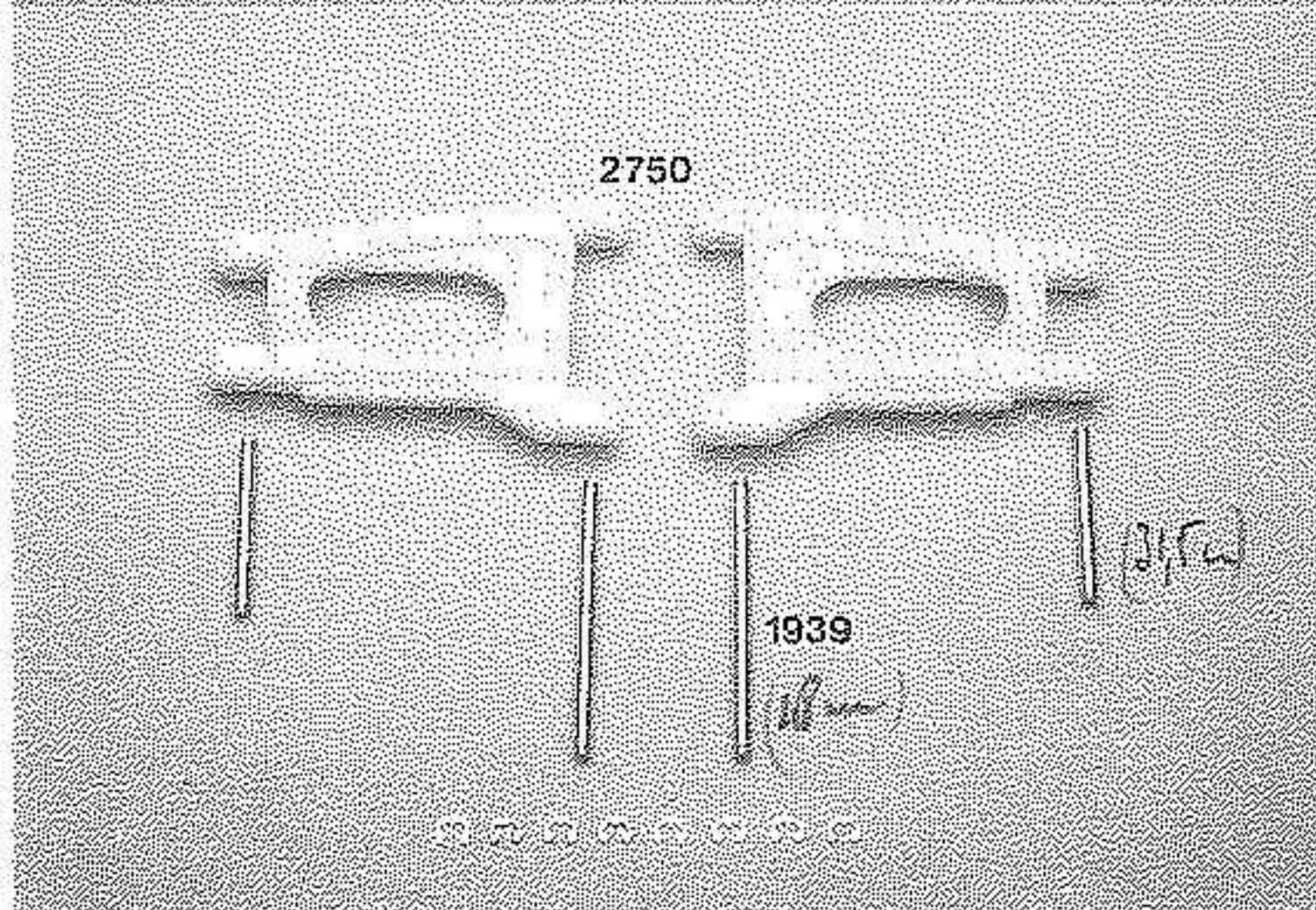

### STEP C-12

Locate the two rear suspension arms (2750), the two longest suspension pins (48mm), two 31.5mm suspension pins, and eight small E-clips (suspension pins and "E" clips are available in replacement Bag #1939).

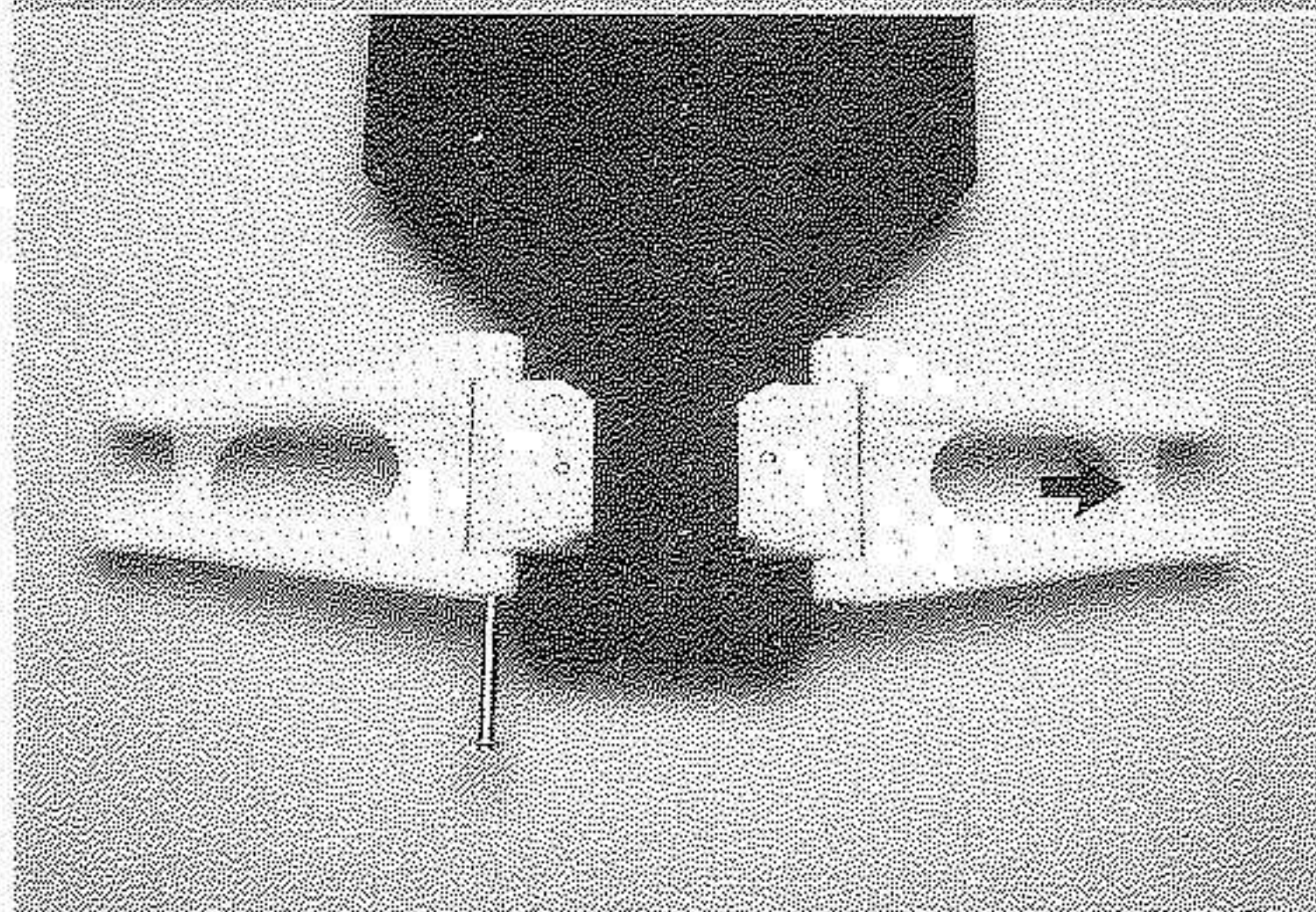

### STEP C-13

Take one of the long suspension pins and snap an E-clip into the groove at one end. There are left and right suspension arms. The dished area (arrow) should be facing you. Mount a suspension arm on the suspension arm mount and insert the suspension pin through the pivot point holes. Repeat for the opposite side. When pushed through, secure the suspension pins with E-clips on the opposite side. A good pair of needle-nose pliers will make easy work of the E-clips. Extras are supplied for the ones that get away.

**RACER'S TIP:** Be sure that all of the suspension arms move up and down freely, without excessive friction or binding. Some material may have to be removed from the inside of the suspension arm pivot points (arrows show location in the Step C-12 photo). Use an X-acto knife or a flat metal file to carefully remove the nylon material. If the suspension pins are binding inside the rear suspension arm mounts, use a smooth, round, 1/8" needle file (such as X-Acto), or a standard oversize 1/8" reamer (.126) to slightly enlarge the holes. Do not oil the pins. The oil will quickly collect dirt and bind the suspension pins.

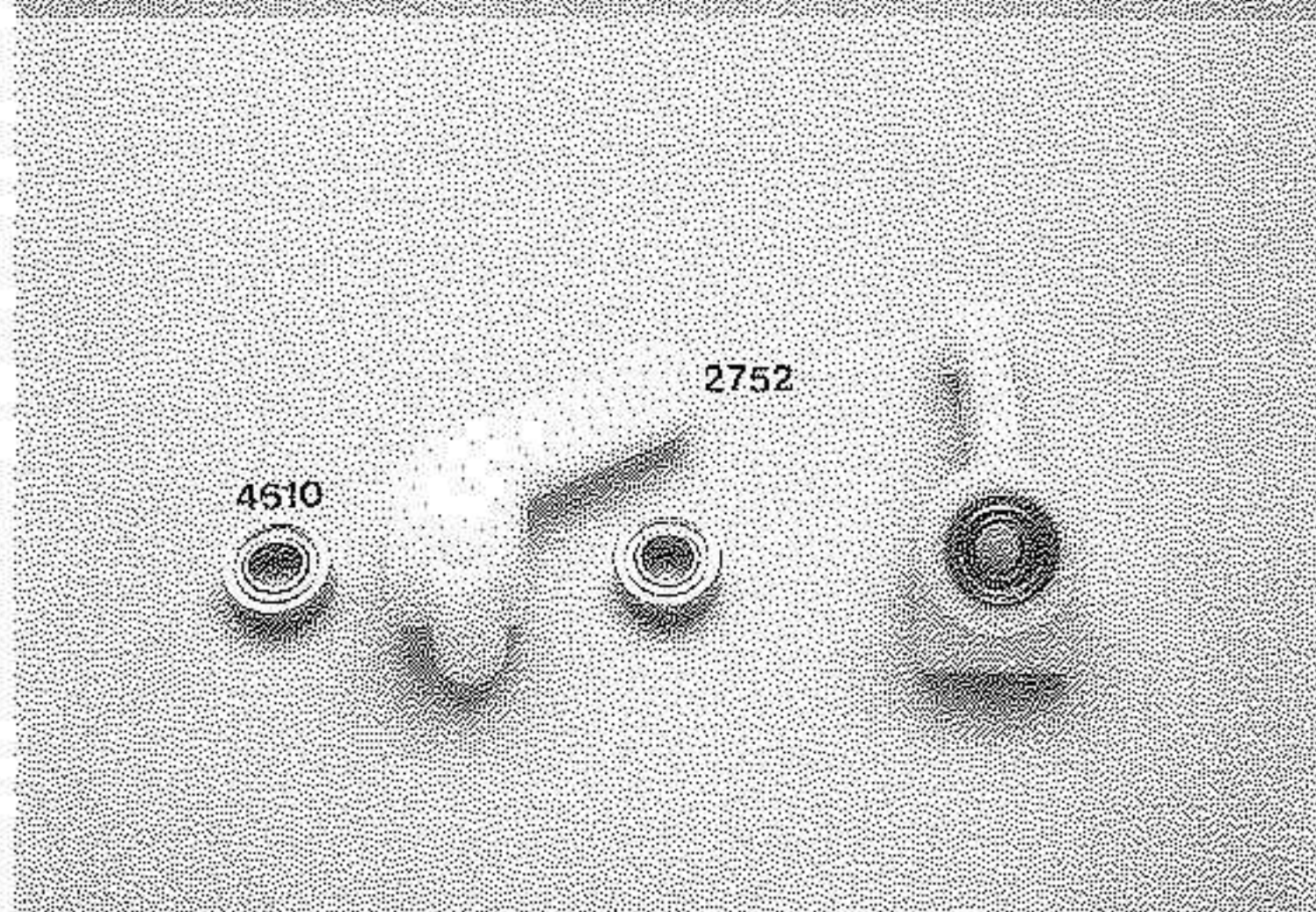

### STEP C-14

Locate the rear stub axle housings (2752) and four 5X11mm ball bearings (4610). Press two bearings into each of the stub axle housings.



### STEP C-15

Position a stub axle housing on each rear suspension arm, as shown. Insert a 31.5mm suspension pin into each pivot point. Use two small E-clips to secure each of the two suspension pins.

**RACER'S TIP:** Refer to the RACER'S TIP in Step C-13 about custom fitting the nylon suspension parts.

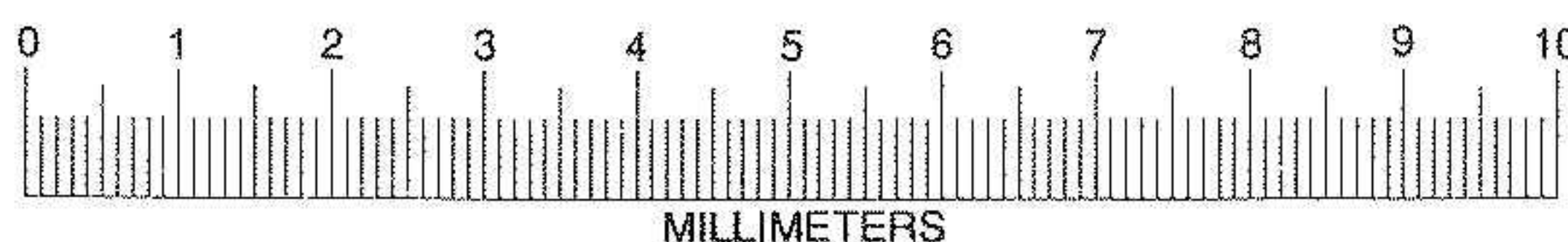

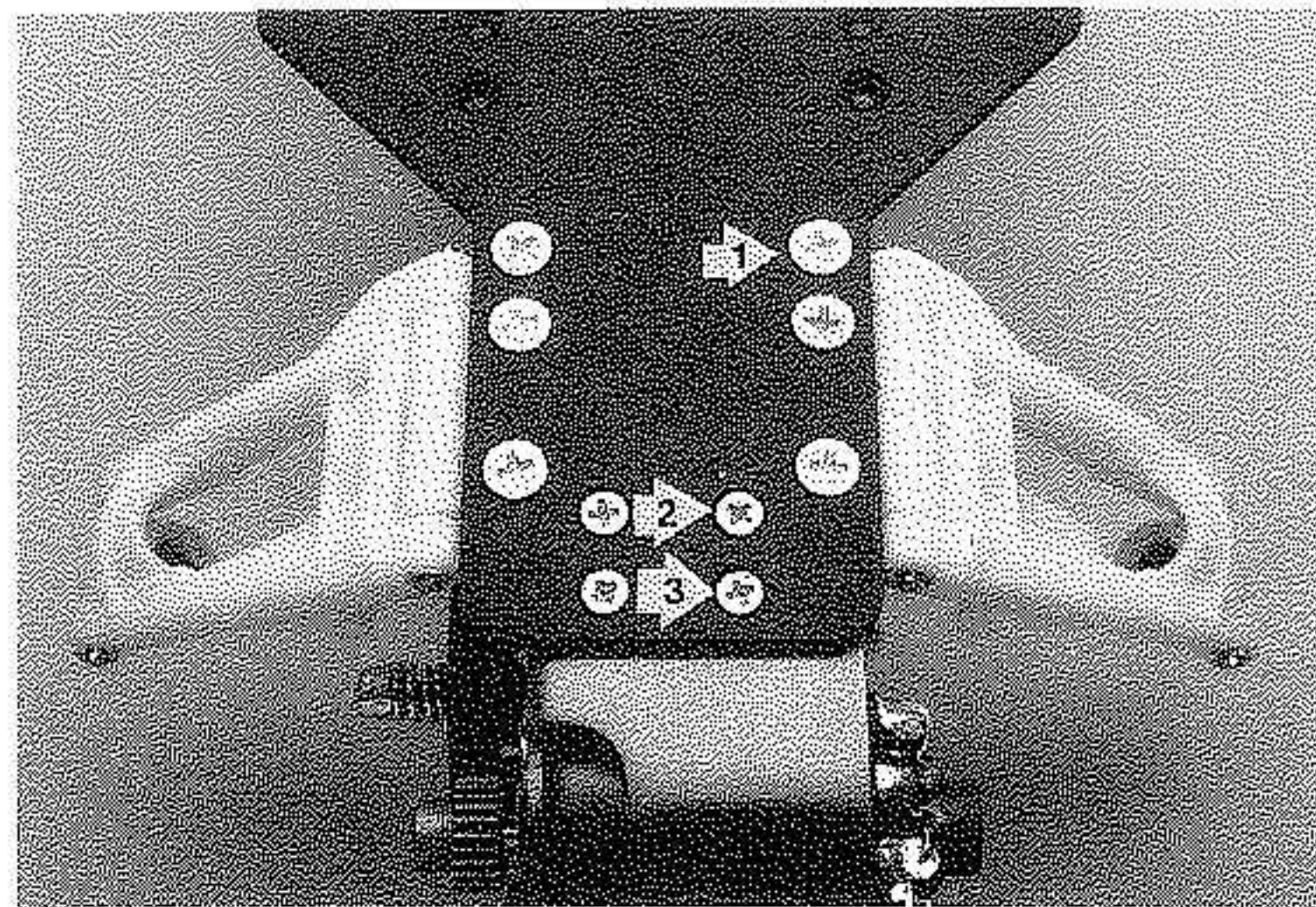

### STEP C-16

Attach the transmission assembly to the chassis with the following screws: Arrow 1, two-4X12mm aluminum countersunk machine screws; Arrow 2, two-3X10mm countersunk machine screws; Arrow 3, two-3X5mm countersunk machine screws. To prevent damaging any of the threads, do not use an electric screwdriver for any of these screws. When securing the rear motor guard with the two 3X5mm screws, you may have to bend the guard slightly to make the holes line up with holes in the chassis.

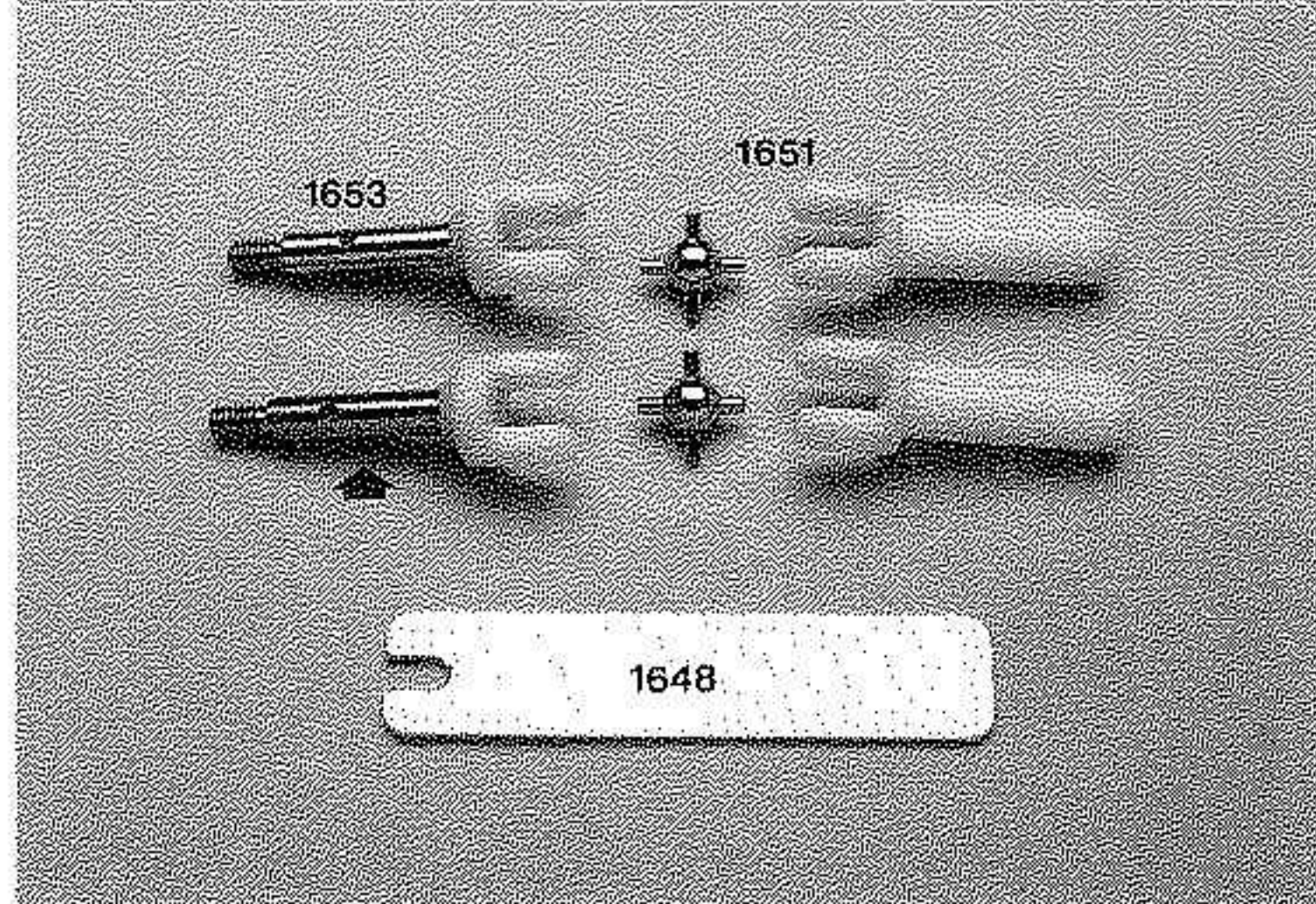

### STEP C-17

Locate the rear stub axles (arrow) (1653), two metal U-joint balls, the external-splined half-shafts (1651), and the U-joint assembly wrench.

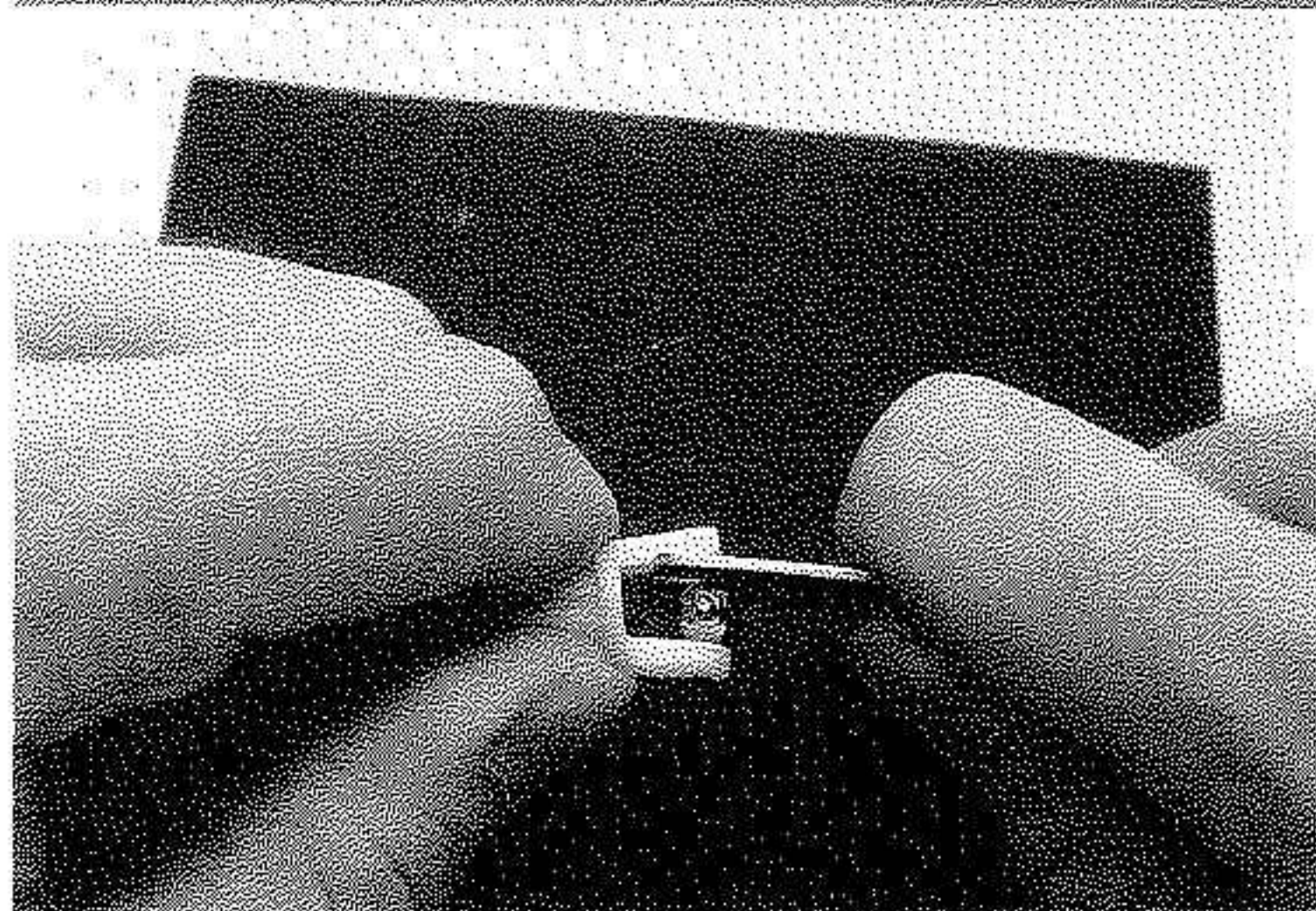

### STEP C-18

Insert one pin of the metal U-joint ball into the external-splined half-shaft. Use the U-joint assembly wrench, as shown, to insert the other pin into the remaining hole. Holding the wrench in your right hand, push down and to the left at the same time (as viewed in the photo).

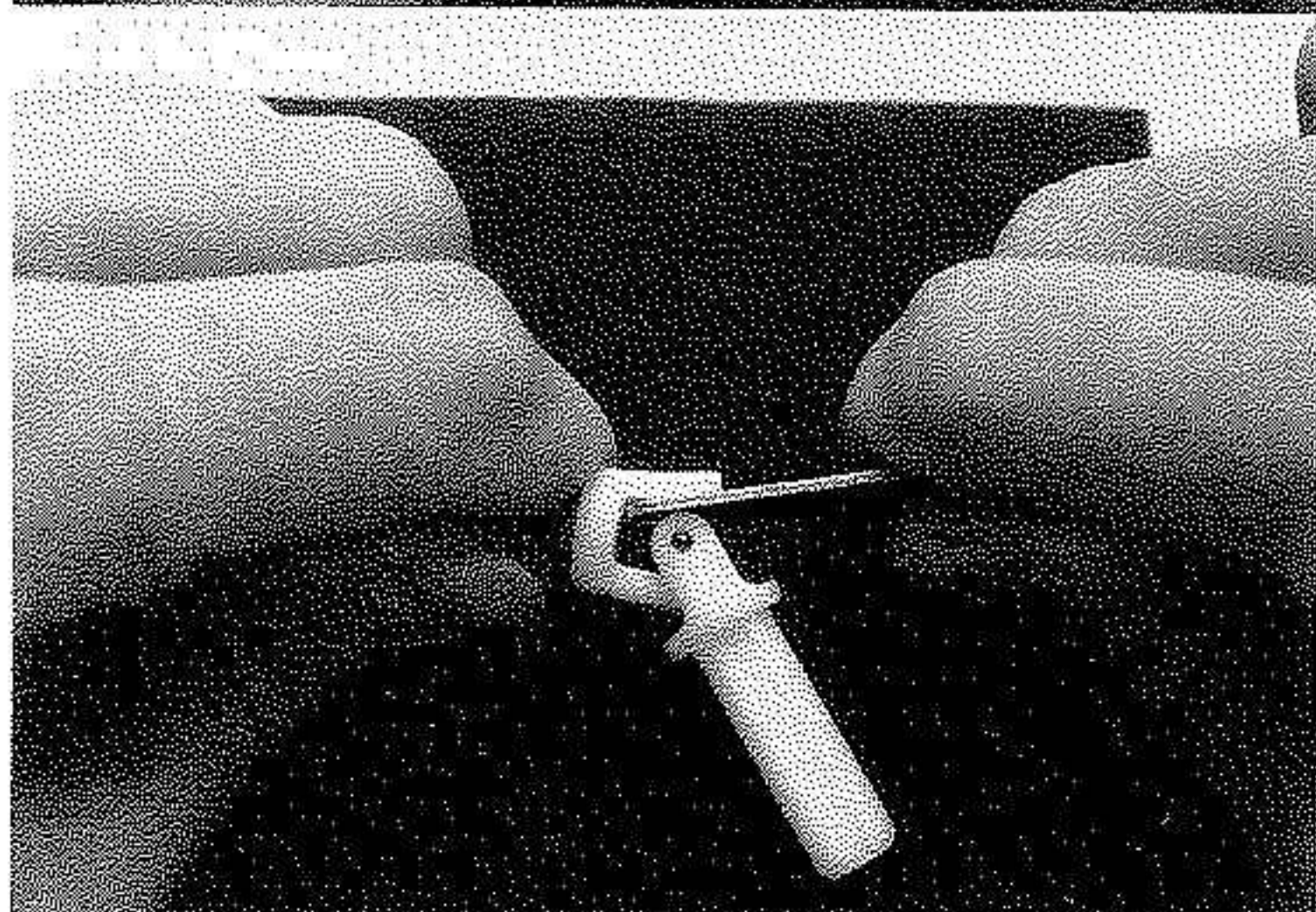

### STEP C-19

Insert one of the remaining metal U-joint pins into the side of the stub axle yoke. Use the U-joint assembly wrench to push the final pin into the other side of the stub axle yoke. Push down and to the left as viewed in the photo.

**RACER'S TIP:** Refer to the tip in Step C-5 about making sure the yokes operate freely.

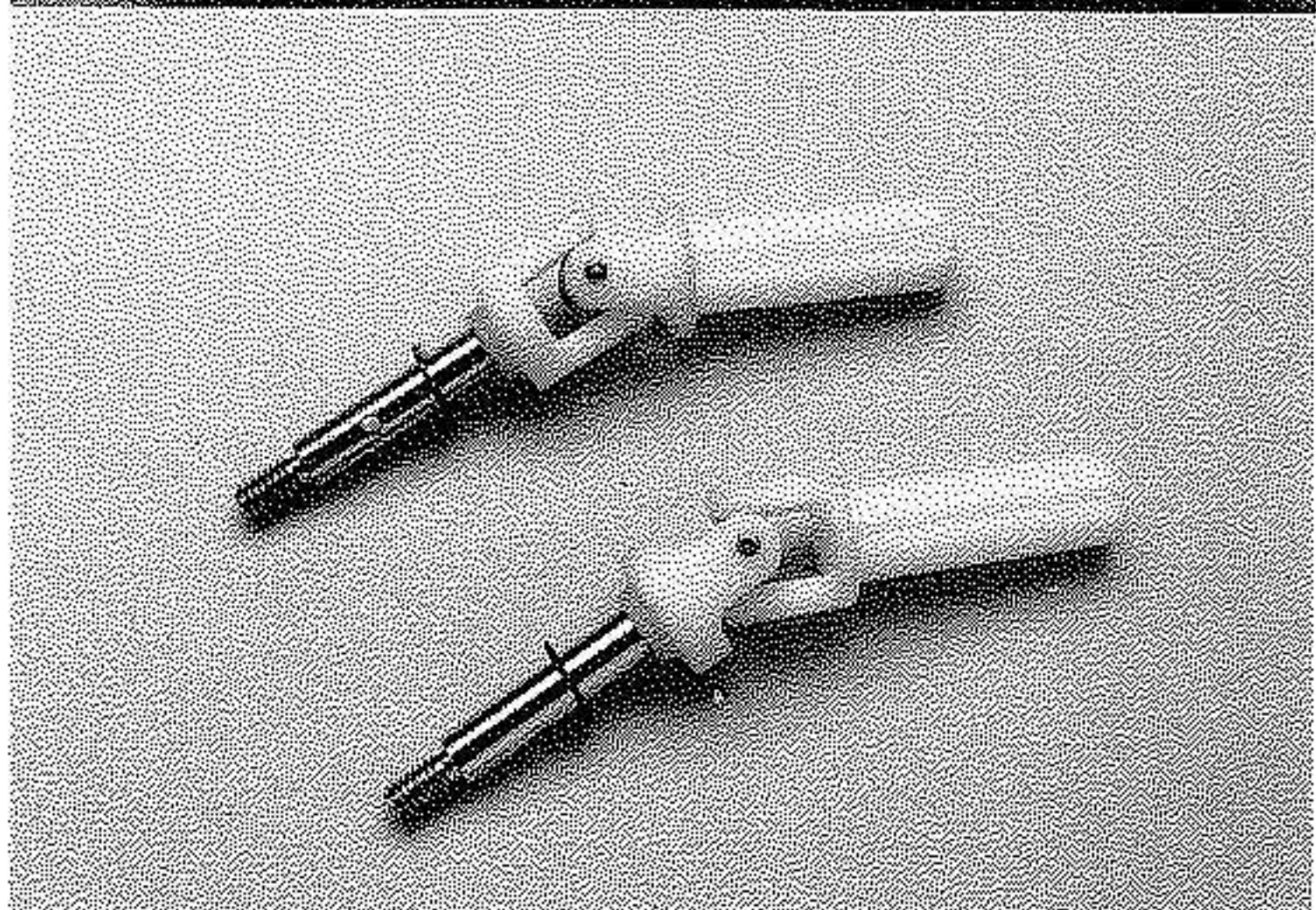

### STEP C-20

Place a 5X8mm fiber washer over each stub axle.

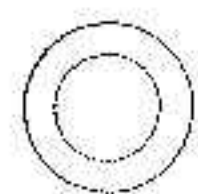

5X8mm FIBERWASHER

3X5mm COUNTERSUNK MACHINE SCREW

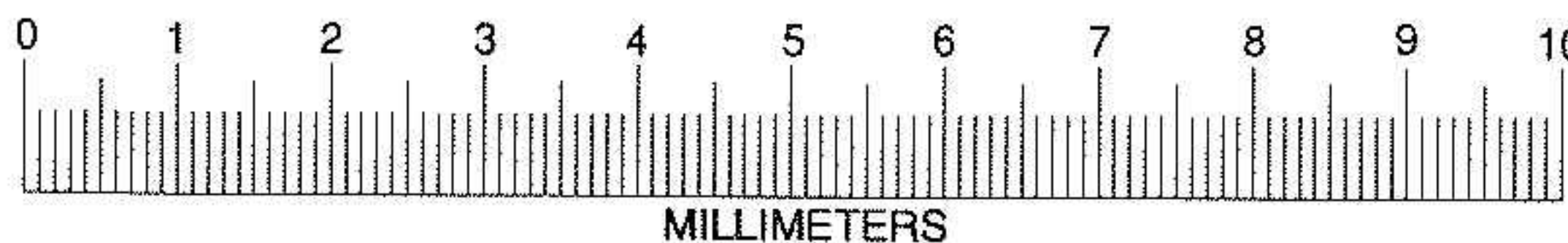
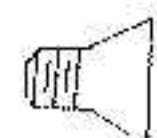

MILLIMETERS

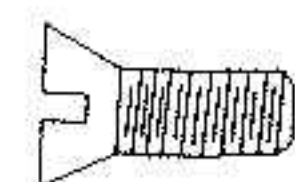

4X12MM COUNTERSUNK MACHINE SCREW

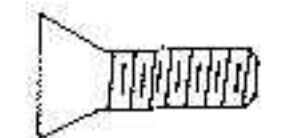

3X10mm COUNTERSUNK MACHINE SCREW

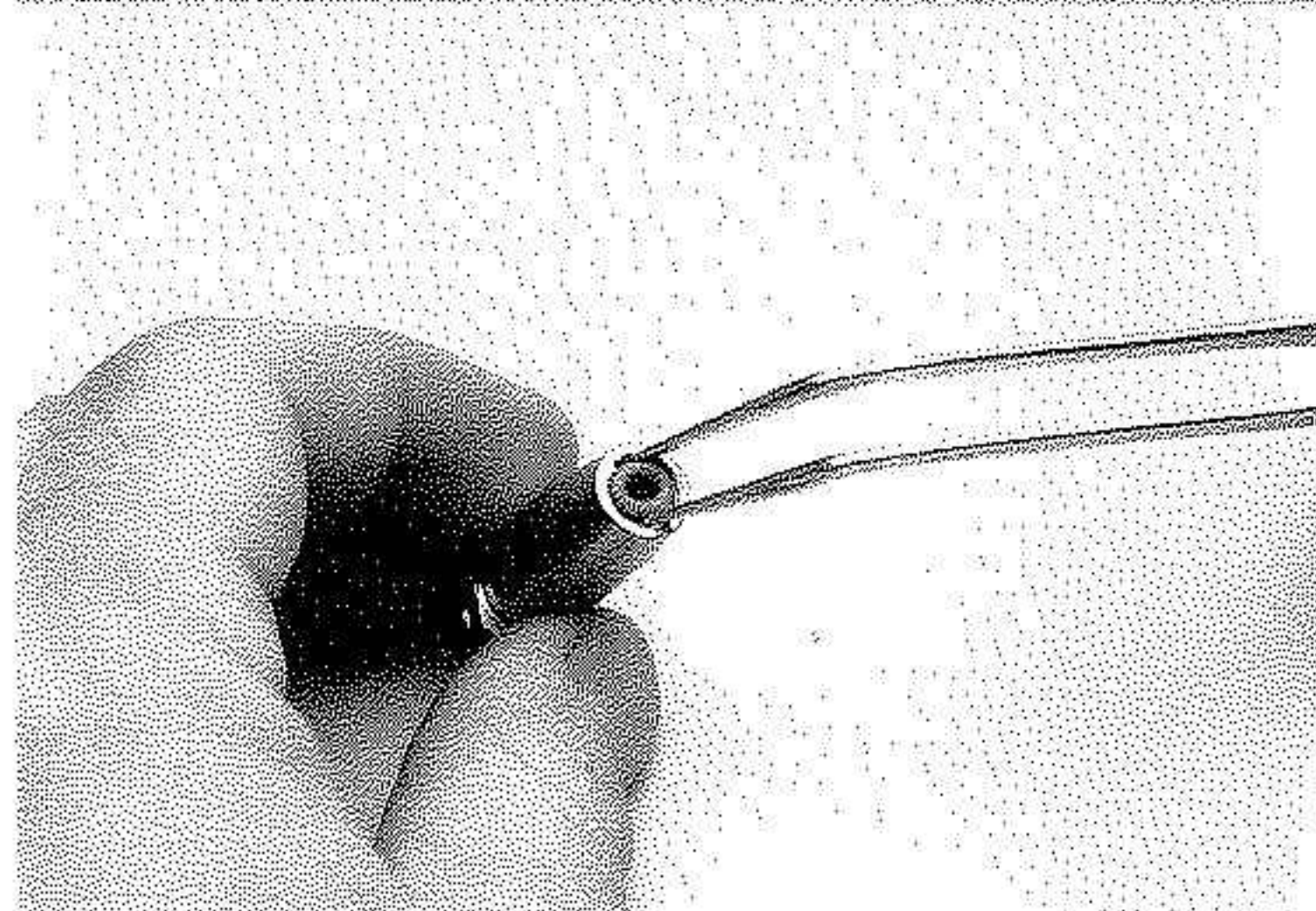
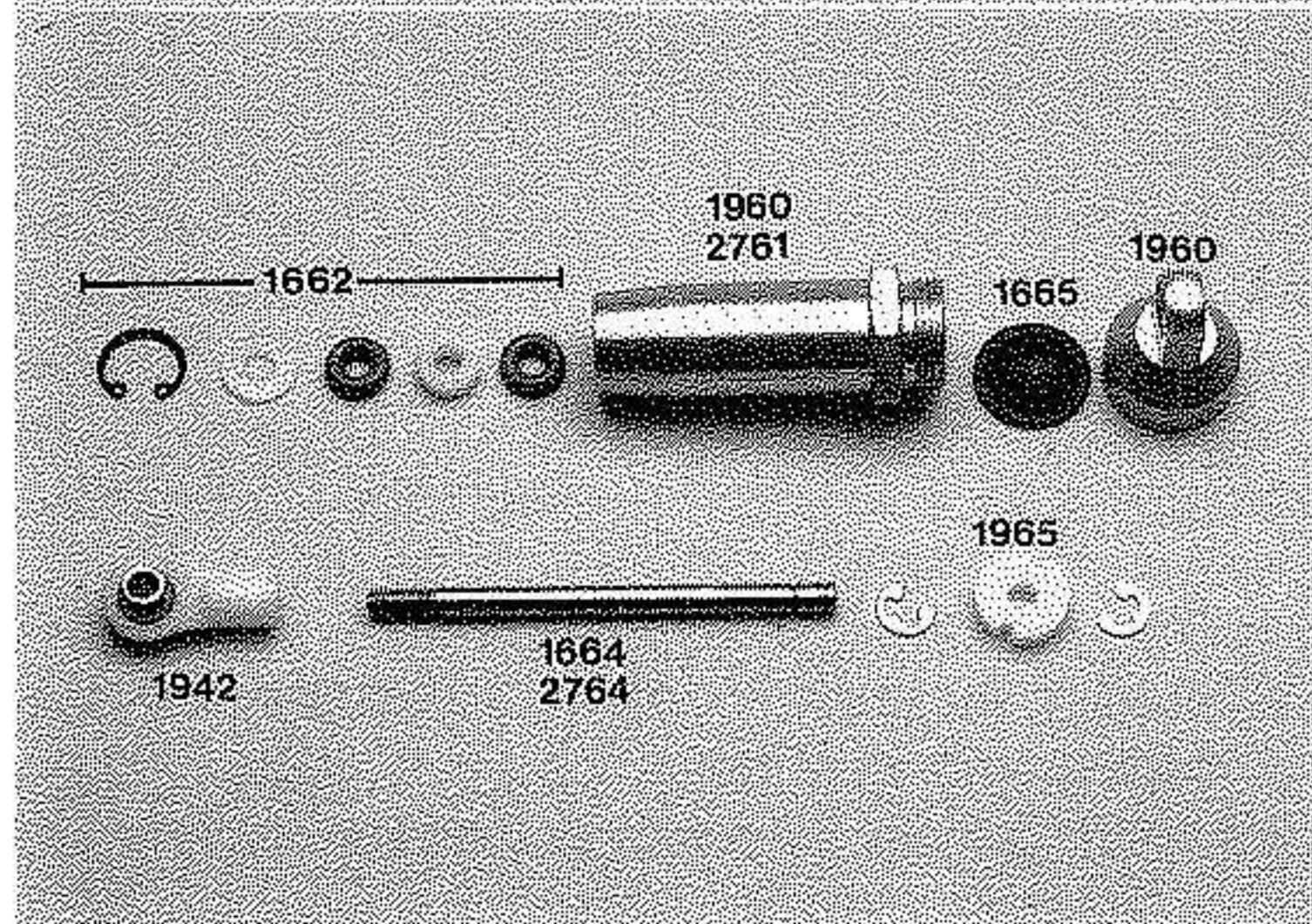
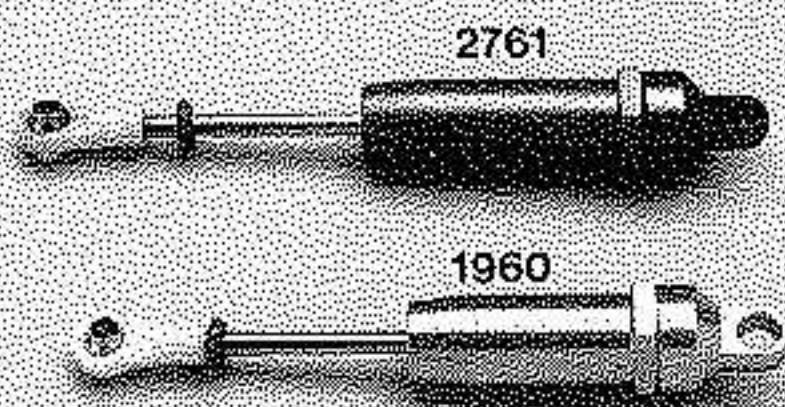
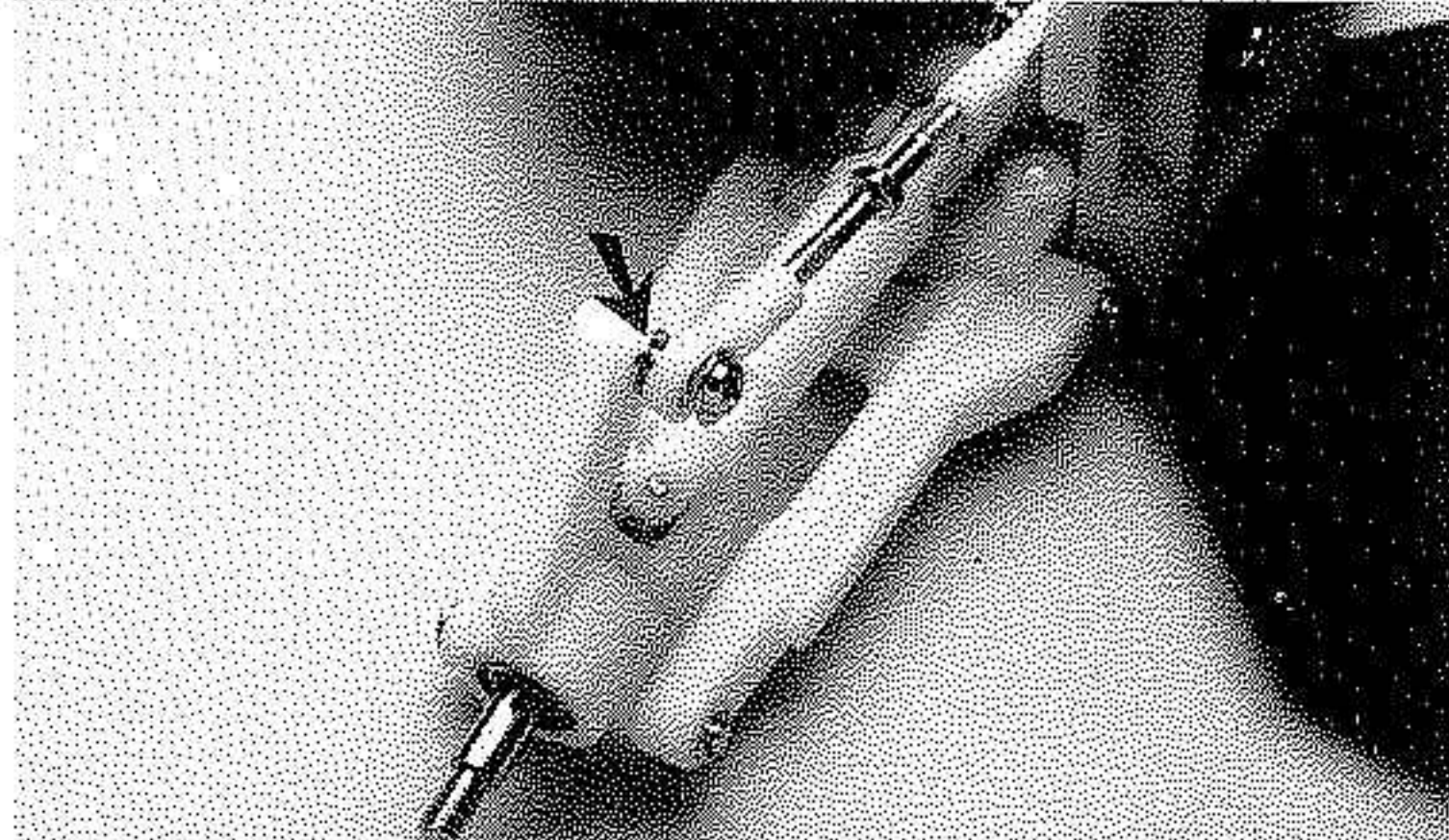
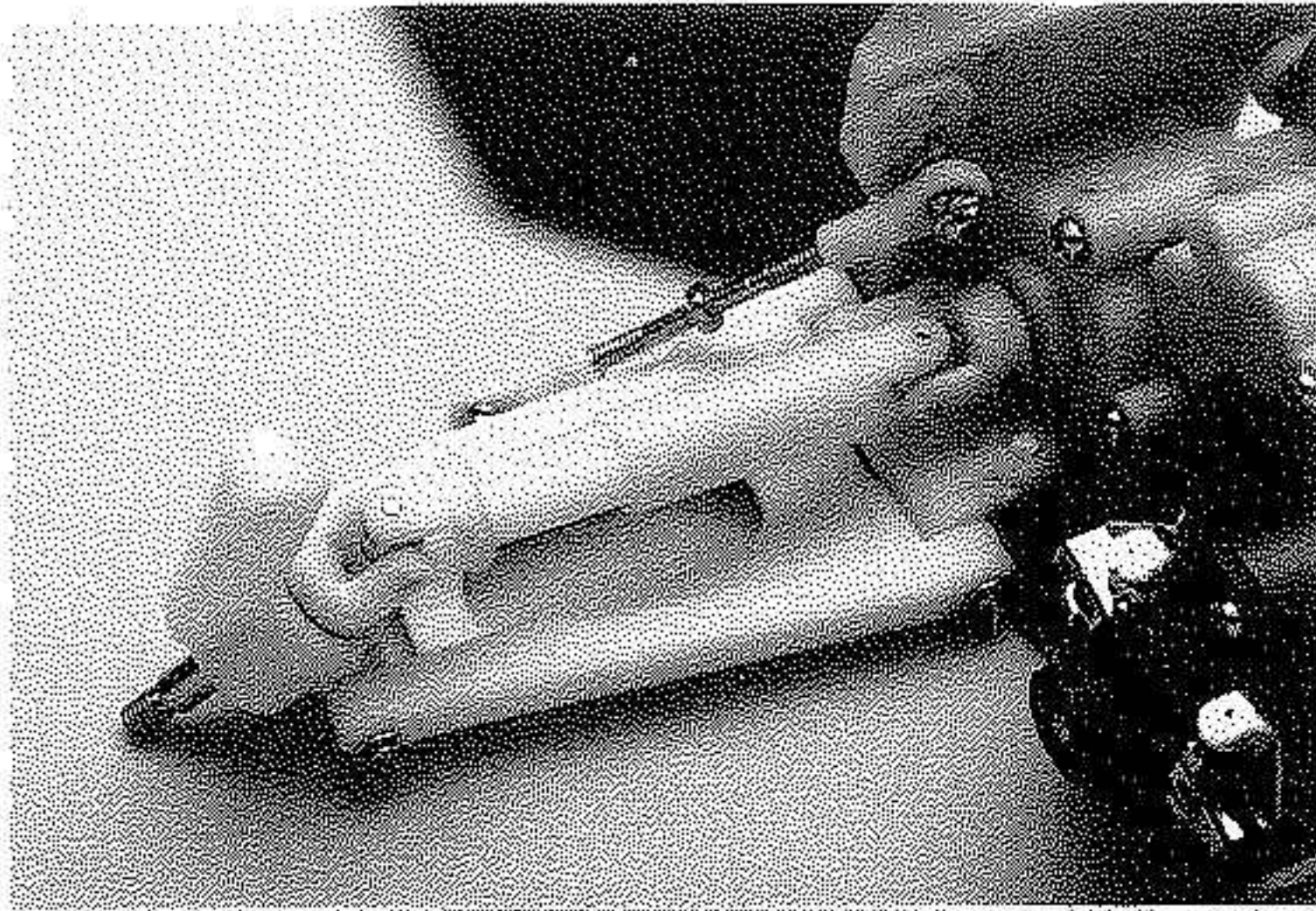

## STEP C-21

Insert the stub axles through the stub axle housings. Next, line up the driveshaft yokes as shown in the photo, and then insert the external-splined half shaft into the internal-splined half shaft. Repeat for the opposite side. If the stub axles do not fit smoothly into the 5X11mm bearings, polish the shafts with fine sandpaper.

## STEP C-22

Attach the other end of the rear turnbuckle to the rear stub axle housing with a 3X12mm washerhead machine screw and a 3X6mm flat metal washer. Place the washer between the ball connector and the stub axle housing (arrow). Repeat for the opposite side.

**RACER'S TIP:** Always use a flat metal washer where a hollow ball connector comes in contact with the nylon. This will prevent the hollow ball connector from digging into the nylon and damaging the part.

## BAG D: SHOCKS

There are two different style shocks used on your car; X-tra long shocks in the rear (part# 2761), and standard long shocks in the front (part #1960). Rebuild kits are part #1662 and contain rubber O-rings, rubber diaphragms, and all the seals, bushings, C-clips, and E-clips necessary to rebuild two shocks. For the best performance, use only 100% pure silicon shock oil.

## STEP D-1

Empty the shock bags out onto a paper plate and separate the parts into like groups. The photo in this step shows the parts and assembly sequence for one shock.

## STEP D-2

Lubricate a red rubber O-ring by putting a drop of oil on it and rubbing it in between your fingers. Push the O-ring into the bottom of one of the T-6 aluminum shock bodies.

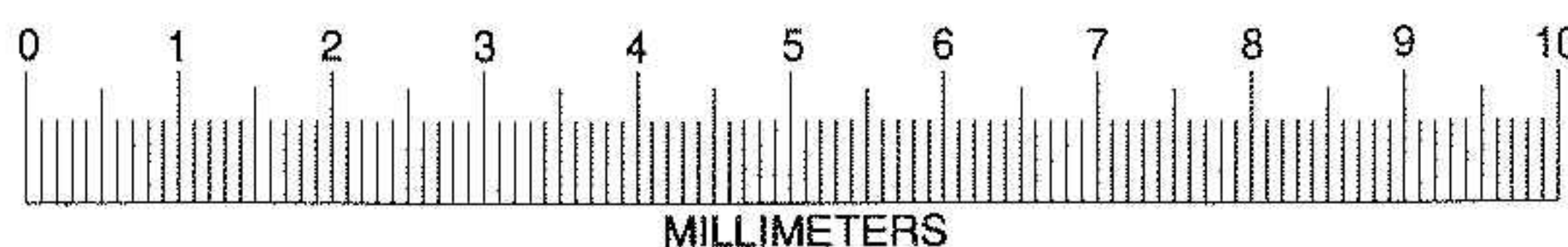

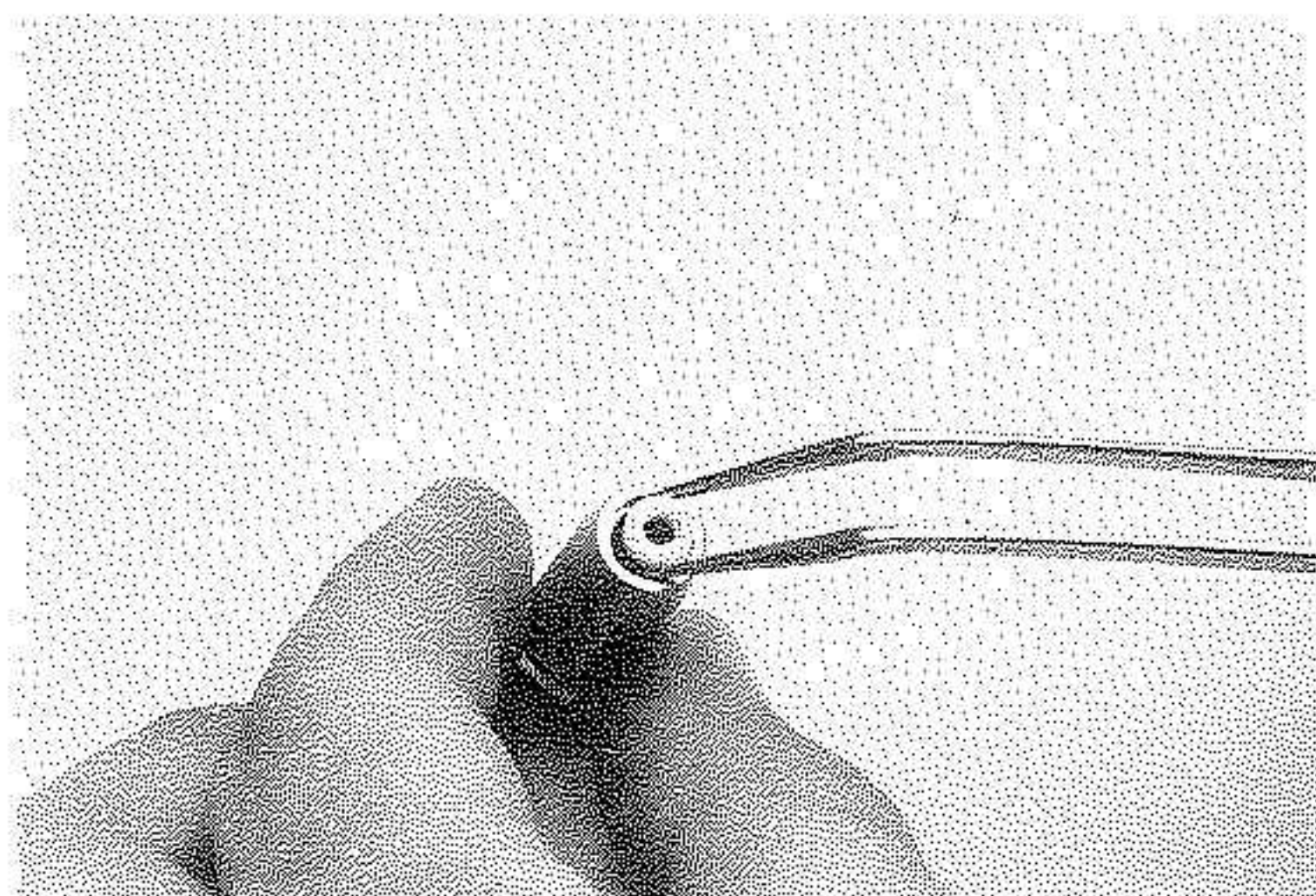

### STEP D-3

Locate the 3X6X2.5mm white teflon spacer, and remove any mold flashings with an X-acto. Do not confuse this part with the 3X6mm nylon washer, which is thinner and off-white in color. Lubricate the spacer and then slide it on and off one of the shock rods (not over the threads) to be sure that the rod slides smoothly without binding.

The teflon spacer is manufactured by a high-pressure stamping tool. The manufacturing process causes the edges of one face of the spacer to be sharp, and the edges on the opposite side to be slightly rounded. Insert the spacer, rounded edge first, into the bottom of the shock body and on top of the O-ring. Push it down firmly to put pressure on the rubber O-ring.

### STEP D-4

Lubricate another red rubber O-ring and insert it into the bottom of the shock body, on top of the white teflon spacer.

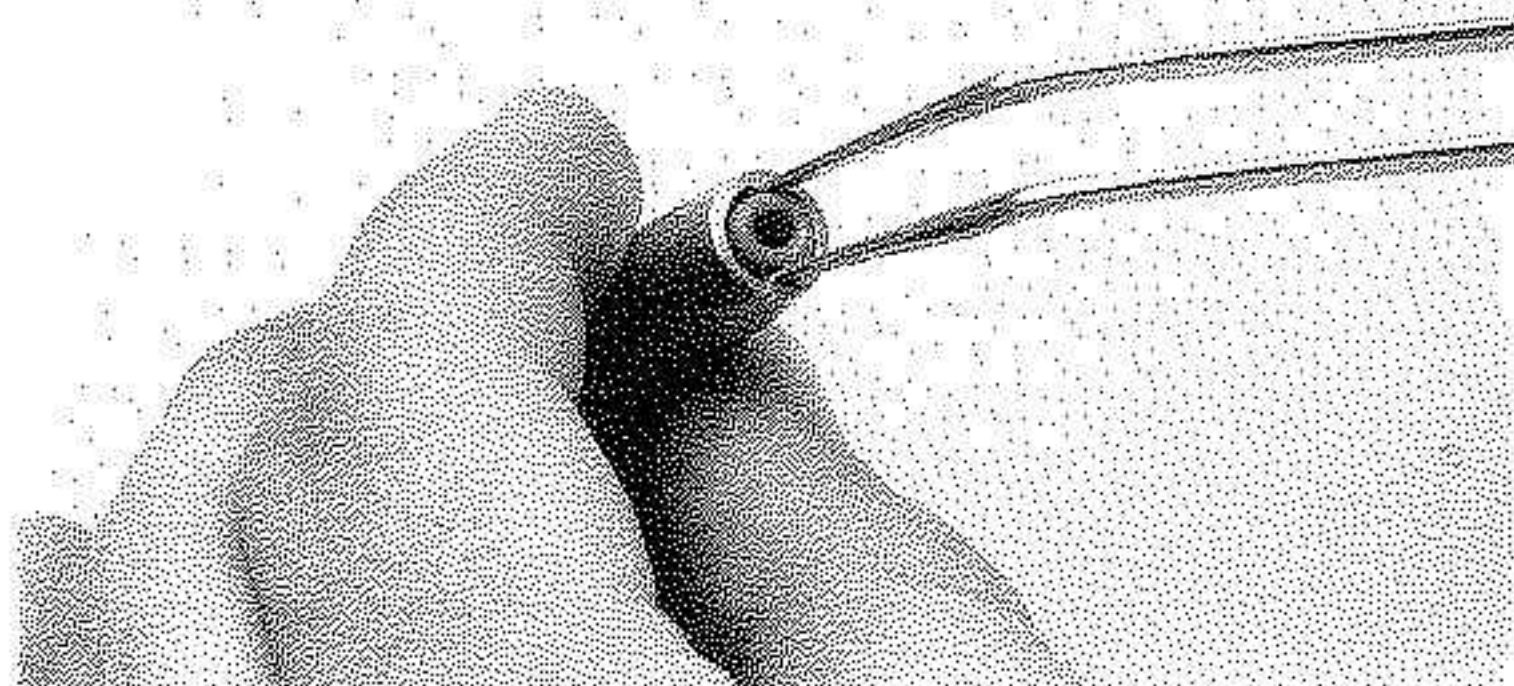

### STEP D-5

Lubricate the 3x7.5x.8mm translucent seal and carefully insert it, rounded edge first, into the end of the shock body. Lightly press it down until you can see the groove inside shock body.

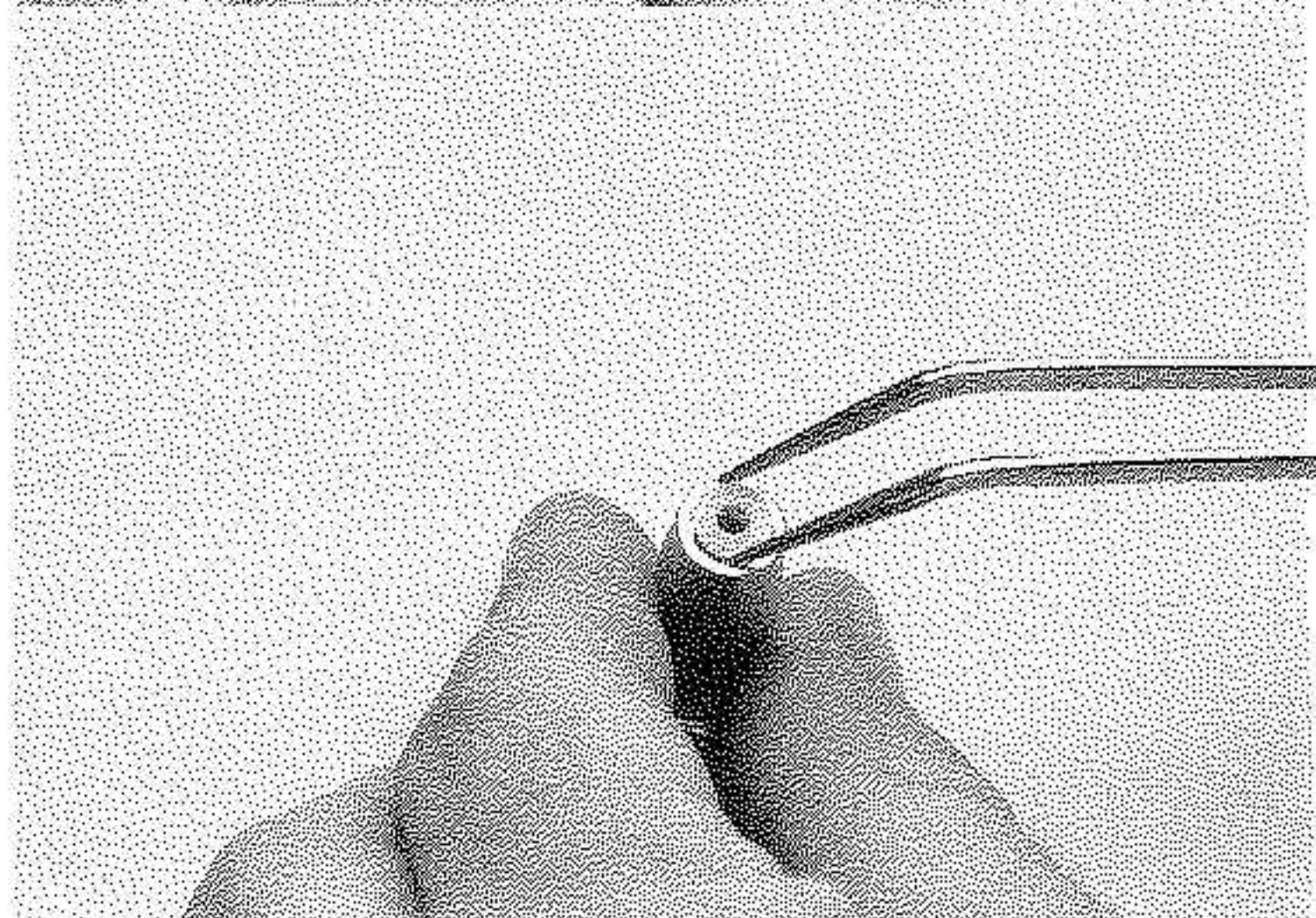

### STEP D-6

Secure the bottom shock assembly by compressing the C-clip and inserting it into the groove machined in the shock body. **It's a good idea to wear protective glasses when working with C-rings because they can spring up into your eyes.** If you do not have any C-ring pliers or strong, sharp tweezers, try inserting one side of the C-ring into the groove and then use a single, strong, sharp-pointed object to manipulate the opposite side into place. If you are having trouble with the C-rings, try assembling these parts with your hands inside a large cardboard box, or in the corner of a room. This way, if the C-ring springs away, it will not fly across the room and be forever lost. Extra C-rings are provided in case of a mishap.

### STEP D-7

Locate one of the shock rods (X-tra long 2764/ standard long 1664). Place a large drop of oil on the end of the shock rod and insert it, grooved end (not threaded end) first, into the bottom of the shock. Wiggle it carefully past the seals. Push it in just enough to leave room for installing the E-clip in the bottom groove. Use needle-nose pliers to snap the lower E-clip into position.

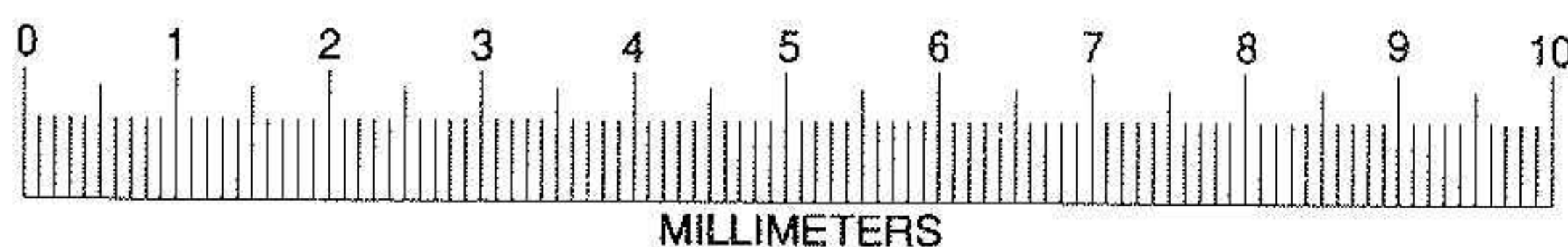
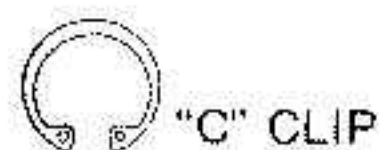
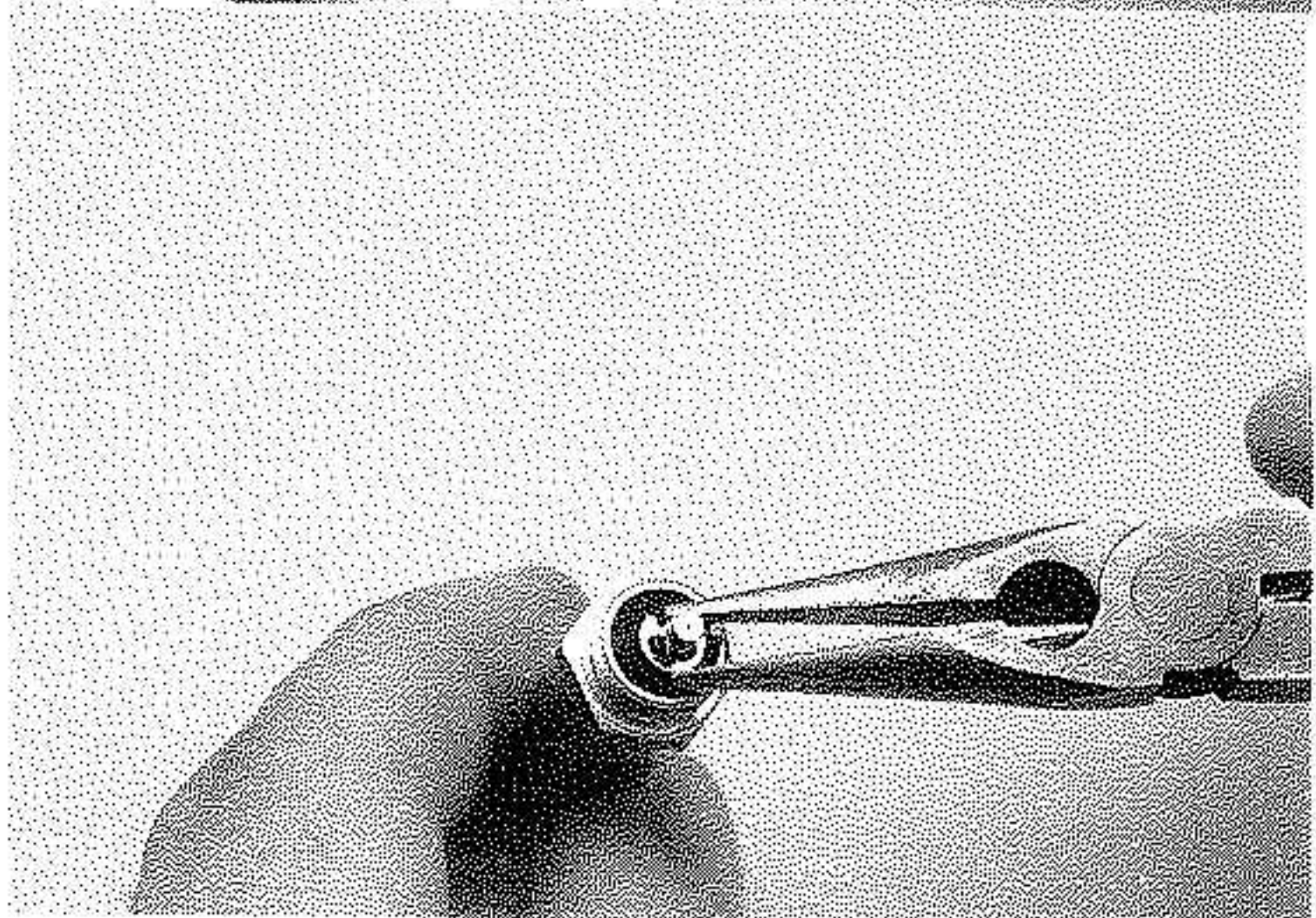
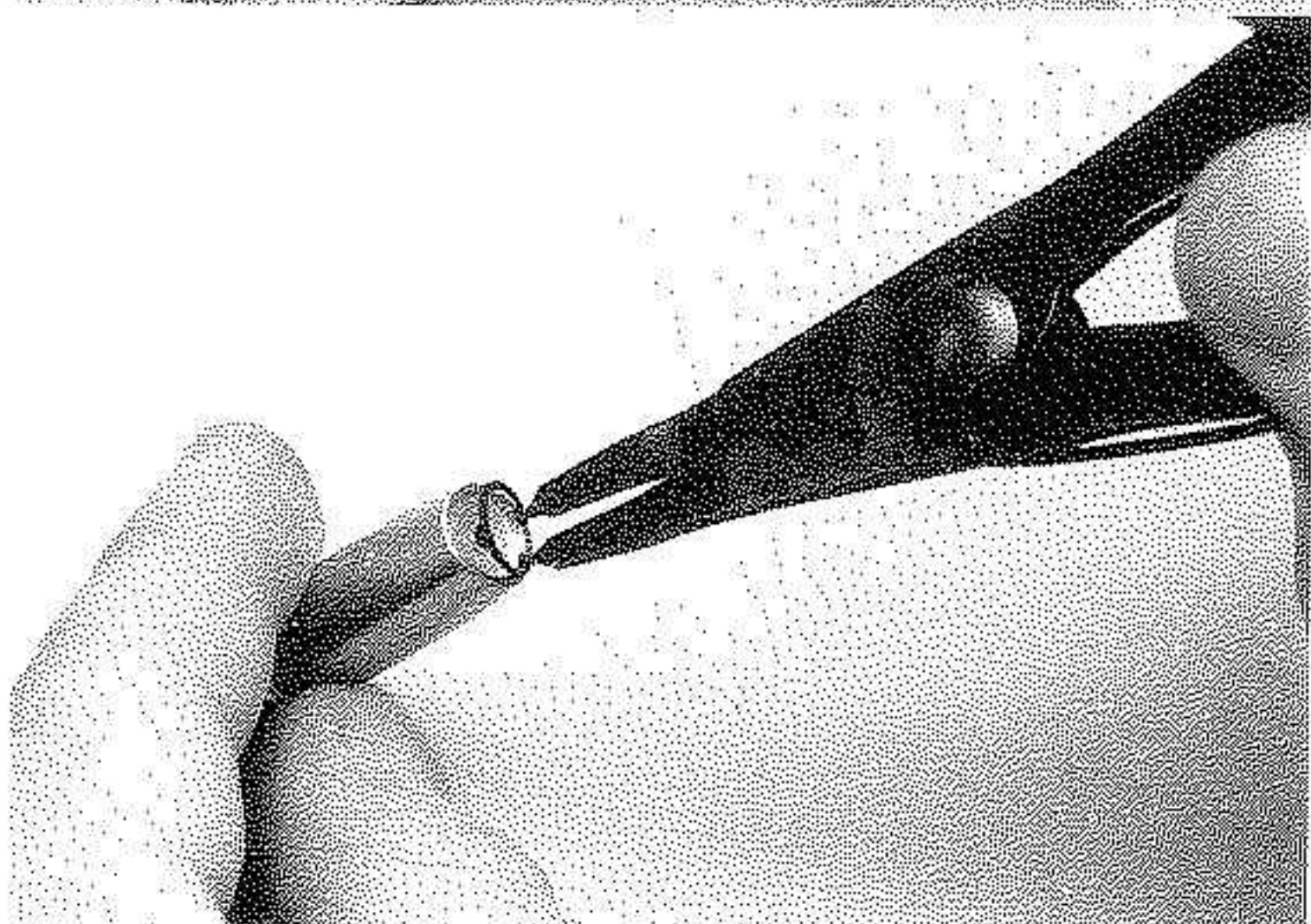



### STEP D-8

Insert a red rubber O-ring over the threaded end of the shock rod. Hold on to the top of the shock rod with your needle-nose pliers and screw on a rod end connector. Be sure to use the 4 short rod ends when assembling the shocks. Never grip the shock rod with pliers below the E-clip.

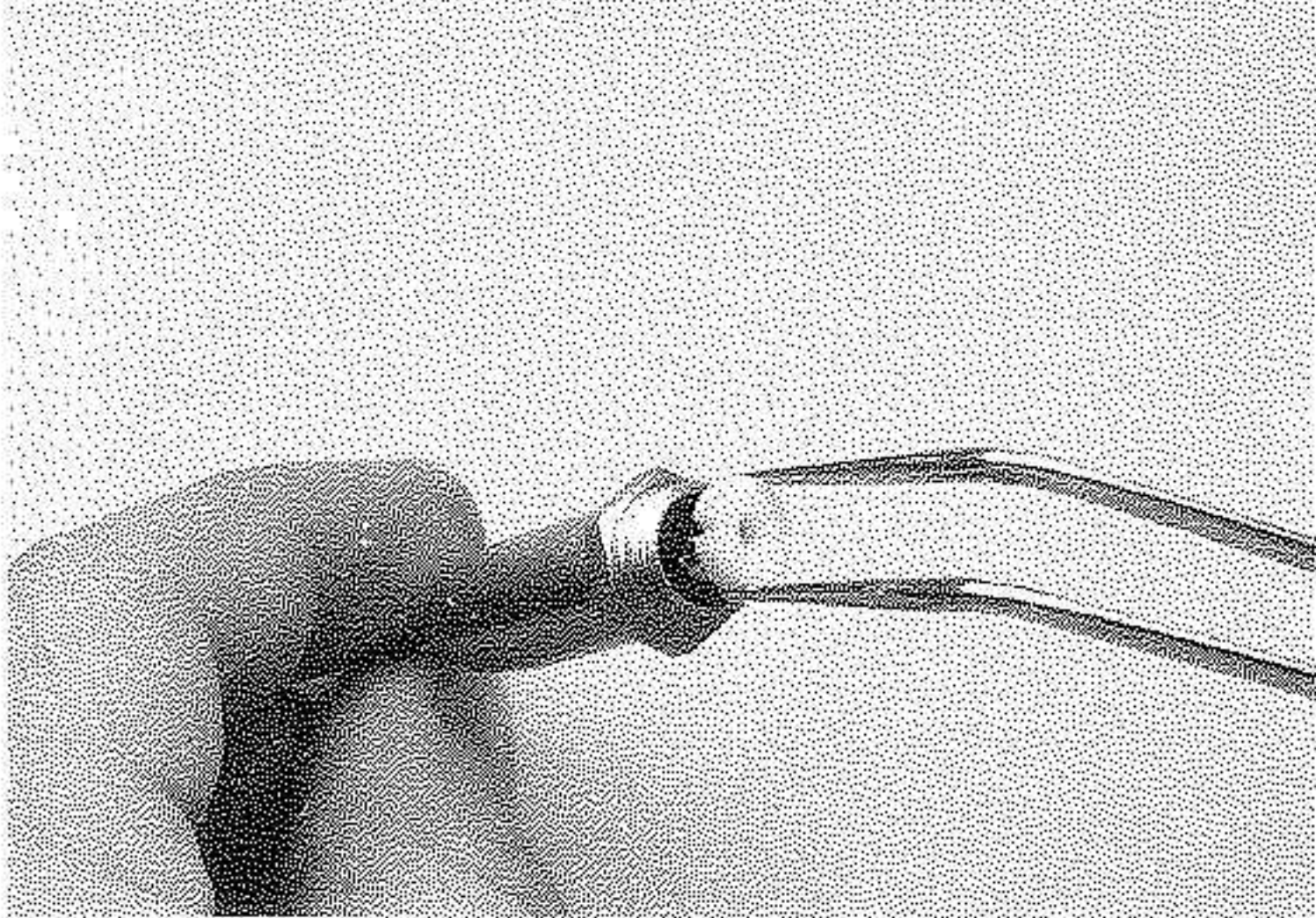

### STEP D-9

Note that the piston heads have a small dimple on one face. Slide the piston head (1965) onto the shock rod with the dimple facing up. We recommend using the 2-hole pistons with the factory shock oil.

**RACER'S TIP:** If you have a selection of different viscosity oils available, refer to the tuning guide in the back of this manual to help you determine which oil and piston head combinations you should be using.

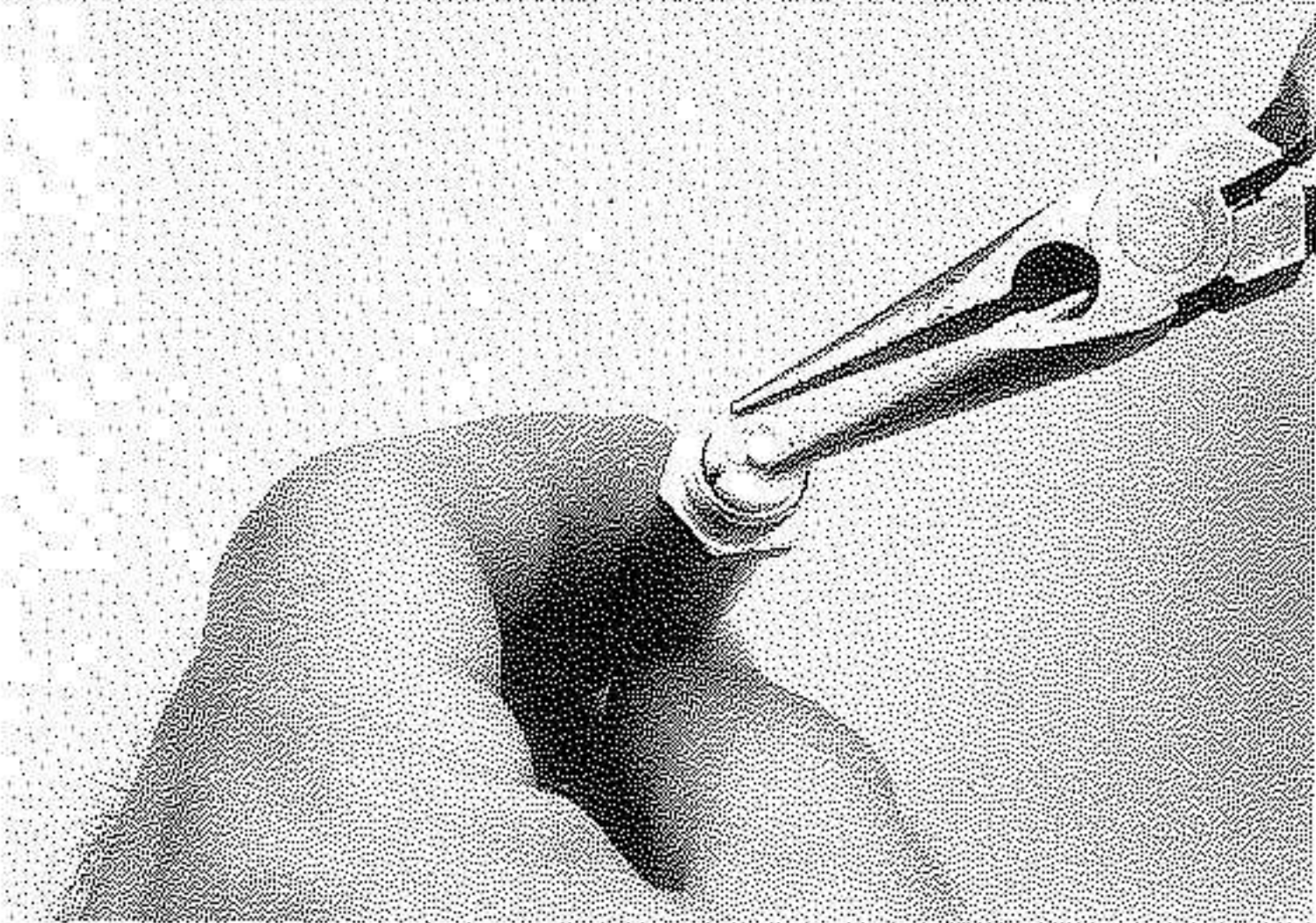

### STEP D-10

Secure the piston head with a small E-clip.

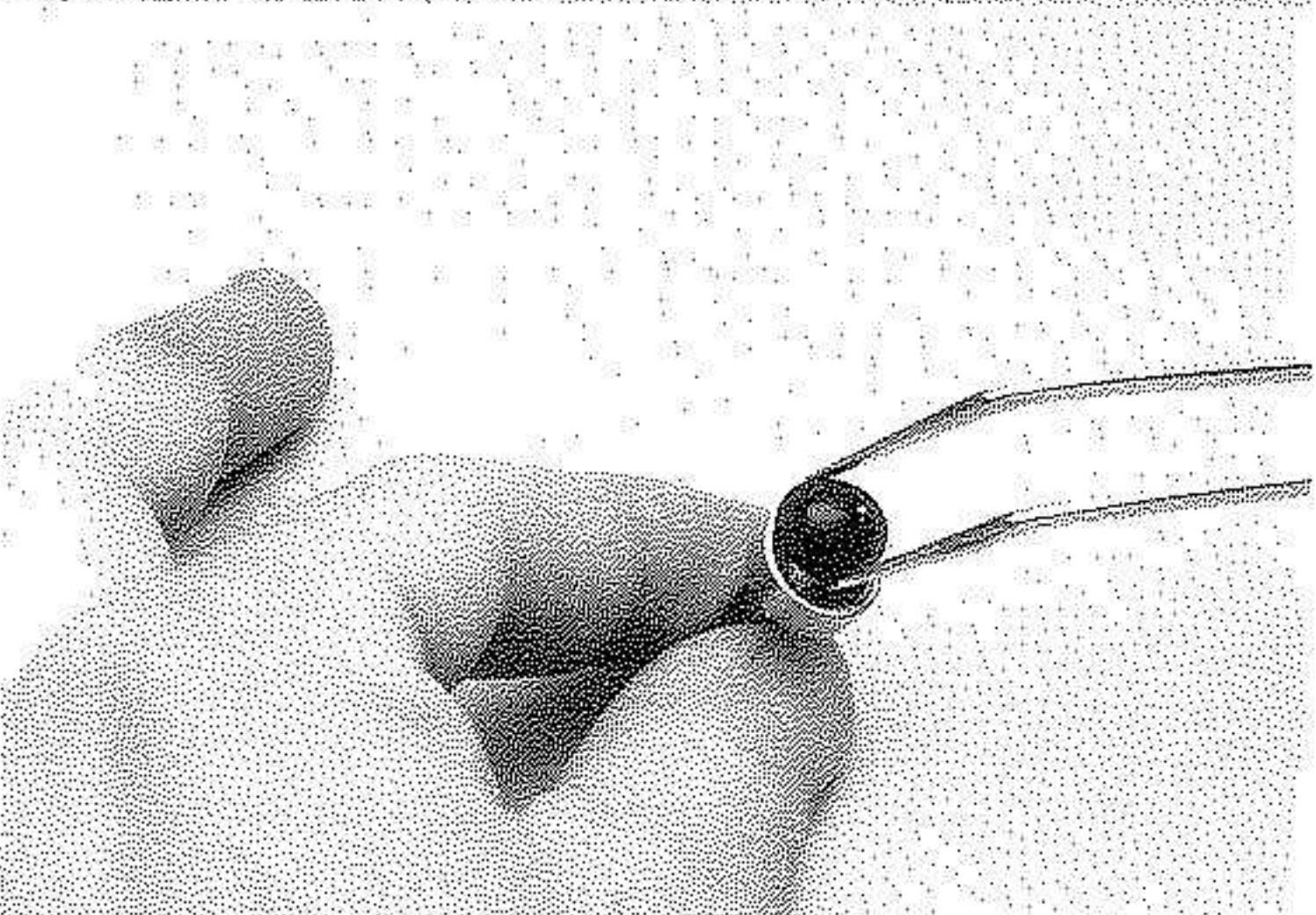

### STEP D-11

Carefully insert a rubber diaphragm (1665) into one of the aluminum shock caps. The rubber dome should face out (down into the shock).

**RACER'S TIP:** Use a small jeweler's screwdriver to be sure the edges of the diaphragm are fully seated into the shock cap.

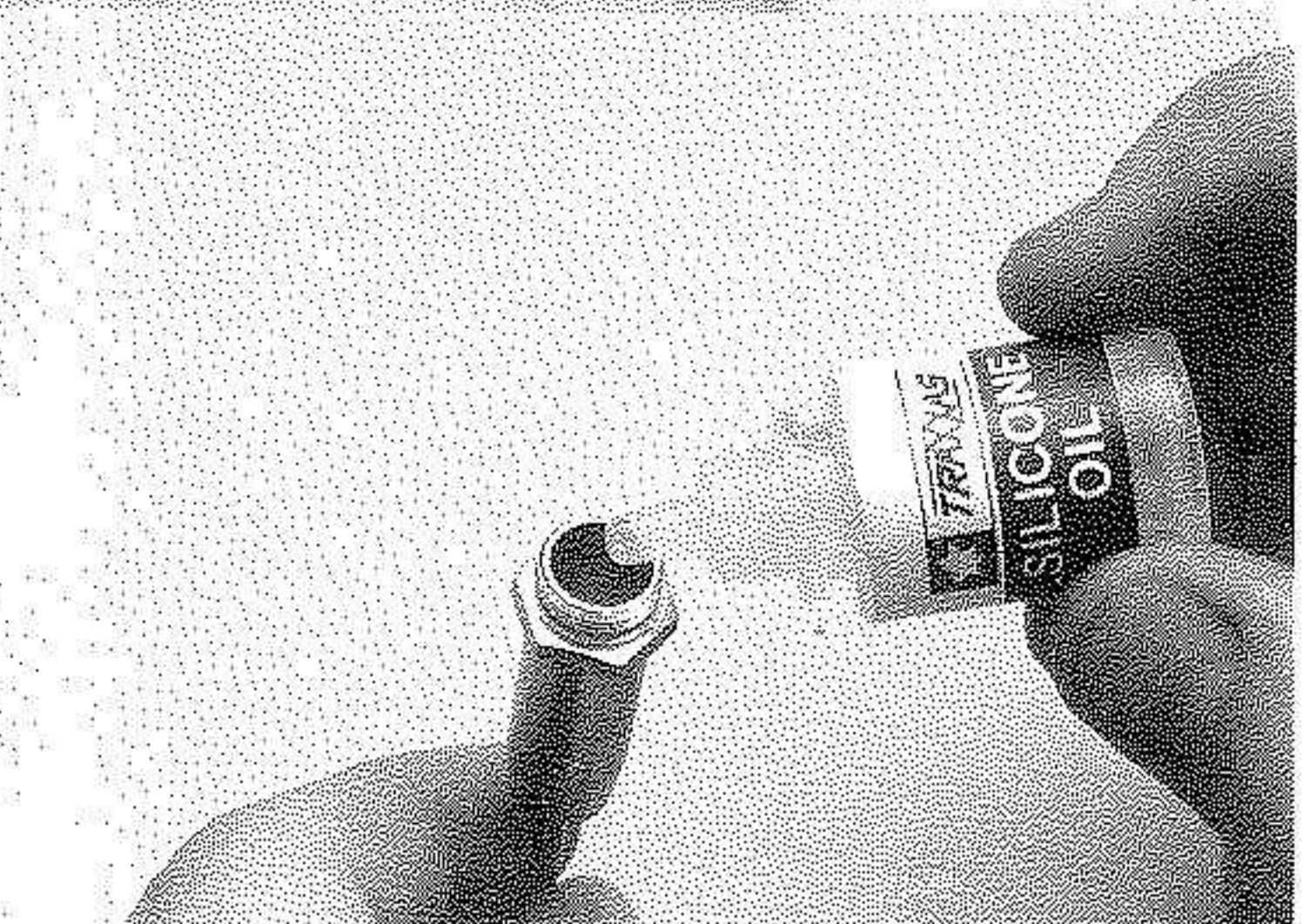

### STEP D-12

Pull on the shock rod so that the piston is at the bottom of the shock body. Fill the shock with oil until it is about 3/4 full. Move the piston up and down while twisting it (keeping it submerged in oil) to release any trapped air bubbles. Finish filling the shock until the oil is right up to the top of the shock body. Now touch the oil in the shock with your index finger and discard the oil that clings to your finger.

**RACER'S TIP:** When releasing air bubbles, pull the shock rod up and down slowly to prevent squirting oil in your face.

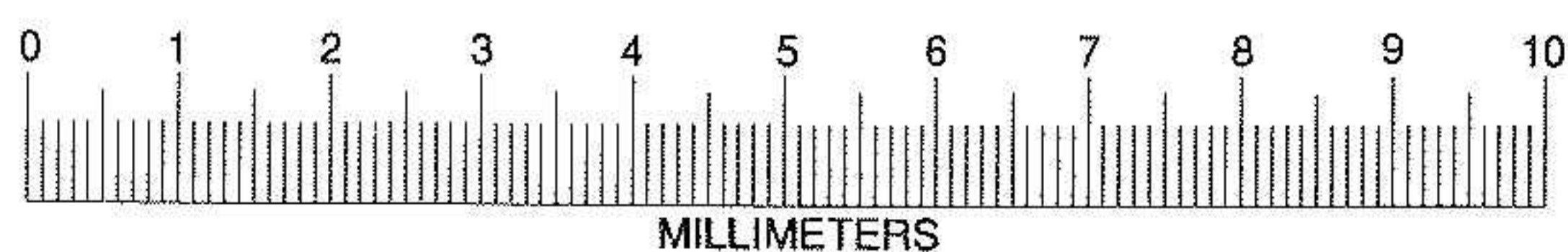

MILLIMETERS

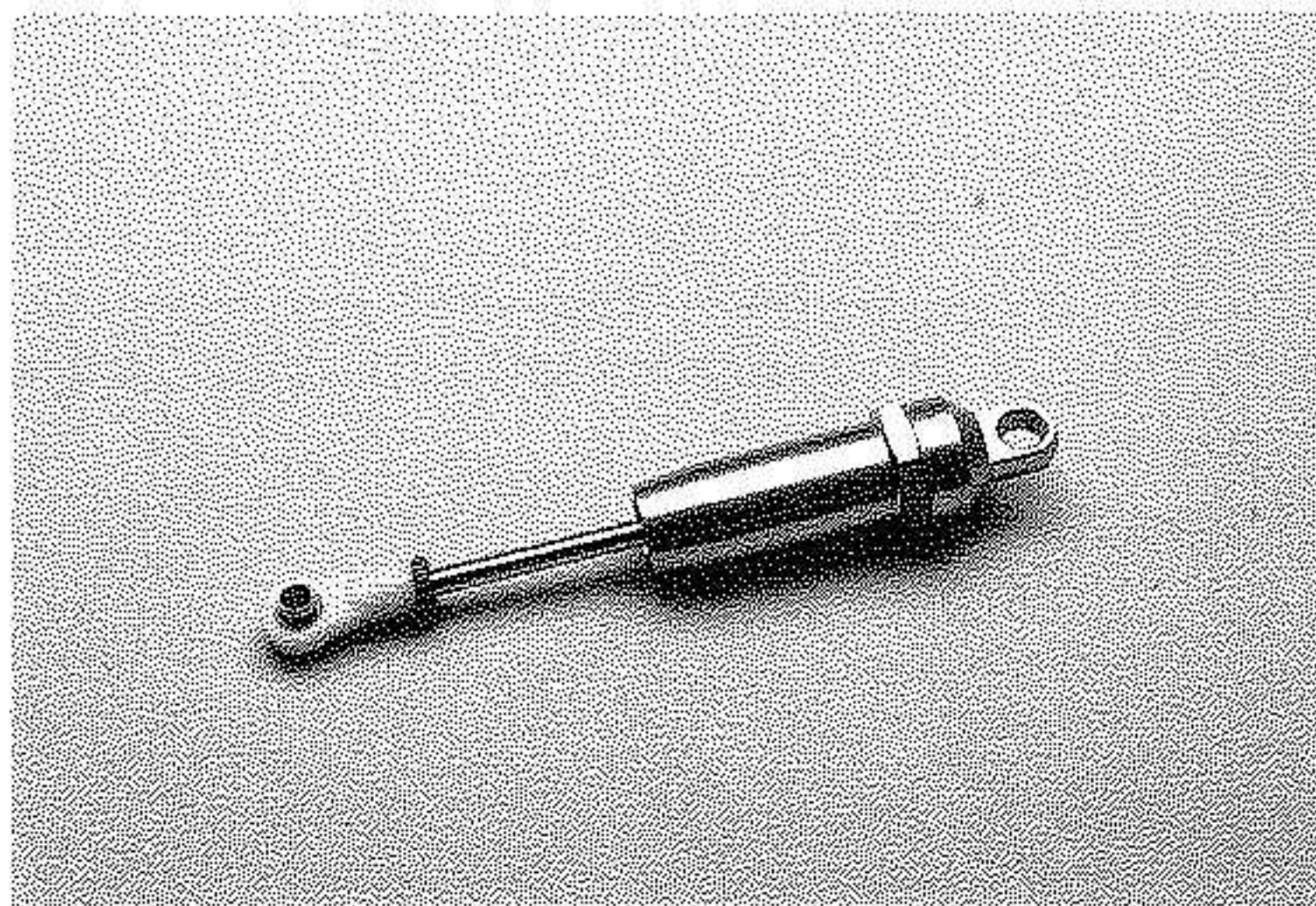

### STEP D-13

Remove any air bubbles from the oil and screw on the aluminum shock cap. Tighten the cap only finger tight. Exercise the shock. If it squeaks, there is still some trapped air in the shock. Remove the air and re-seal the shock until it operates smoothly and quietly.

**RACER'S TIP:** The rubber diaphragm is an extremely important part of the shock's operation in that it causes the shocks to actually be pressurized. Unlike conventional shocks, the caps should not be more than finger tight. Over-tightening will damage the diaphragm and decrease the shock's performance.

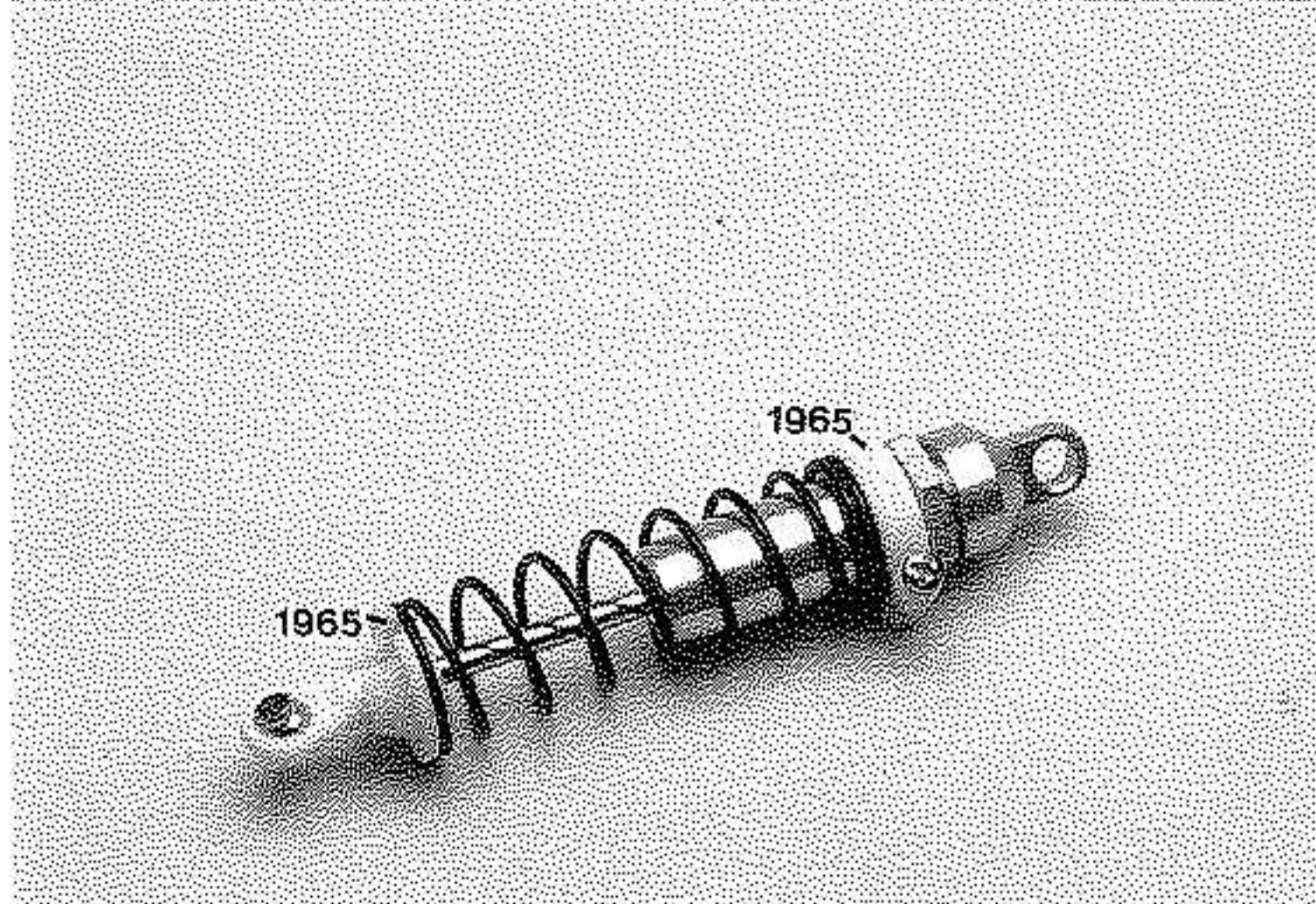

### STEP D-14

Locate the shock collar (1965). Note that the hole on one side is larger than the other. Insert a 2.6X10mm self-tapping screw through the large hole so that it taps into the smaller hole. Slide the collar over the shock. Slide on one of the springs (4651 front, 4655 rear) over the shock and secure it with a spring retainer (1965).

Repeat Steps D-1 through D-14 for the three remaining shocks.

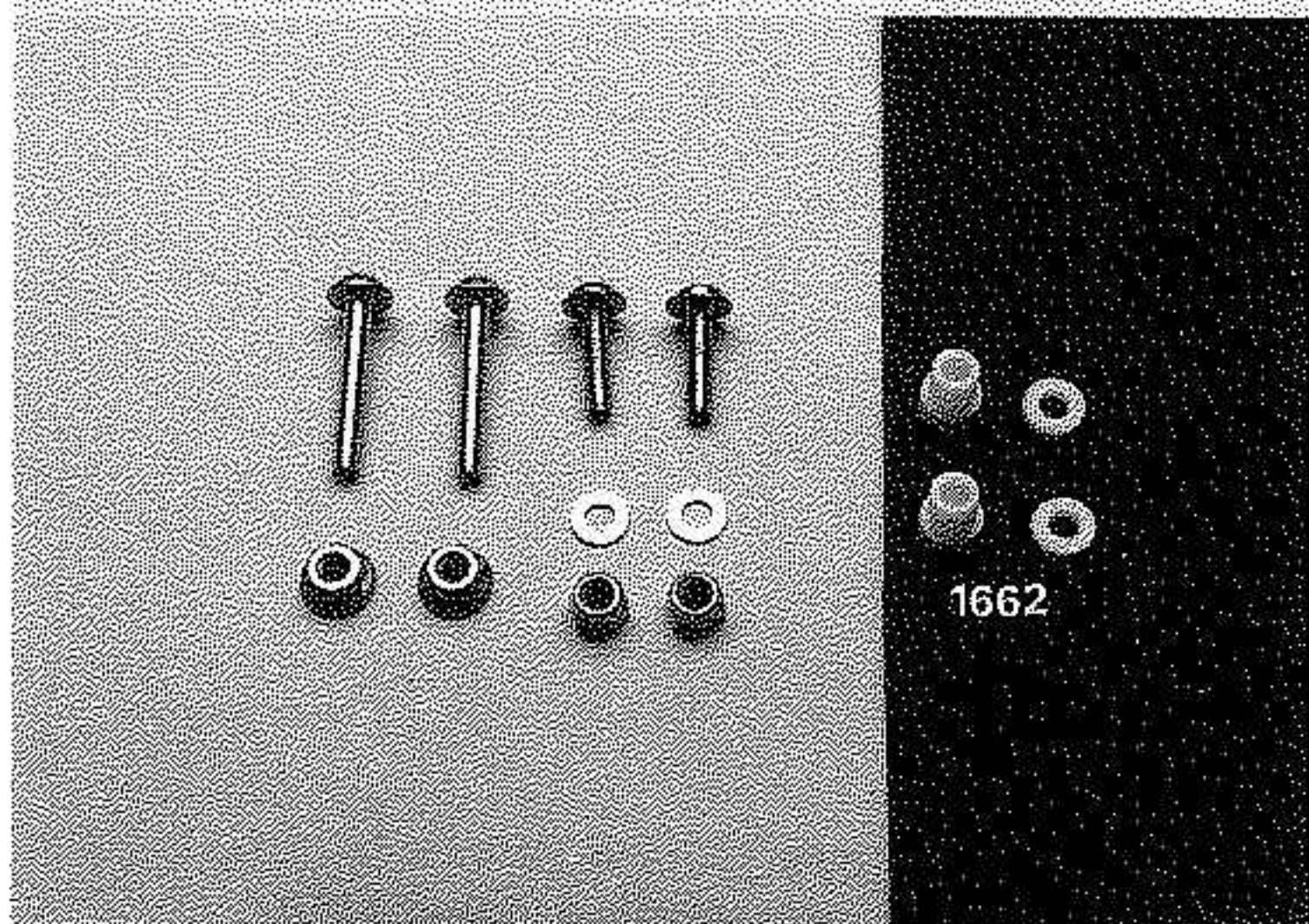

### STEP D-15

Locate two 3x20mm washerhead machine screws, two 3x12mm washerhead screws, two nylon oil damper mounting bushings (1662), two 3x6mm nylon washers (1662), two 3mm flange nuts, two 3mm lock nuts, and two 3x6mm flat metal washers.

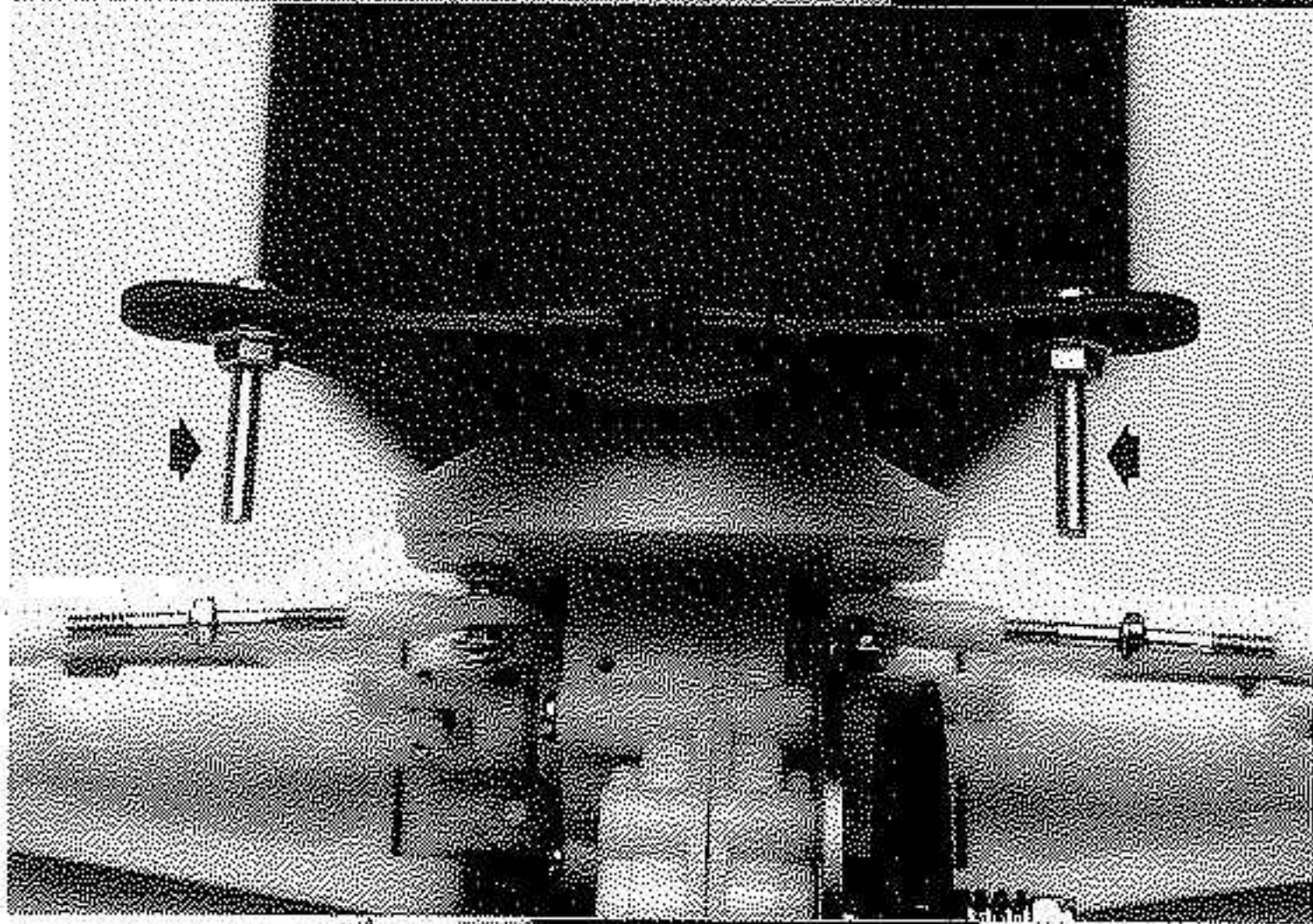

### STEP D-16

On each side of the rear shock tower, there are three possible shock mounting positions. Use the center hole on each side as a starting point. On each side, insert the 3X20mm washerhead screw through the front side of the shock tower. Screw a flange nut down on each screw, as shown in the photo.

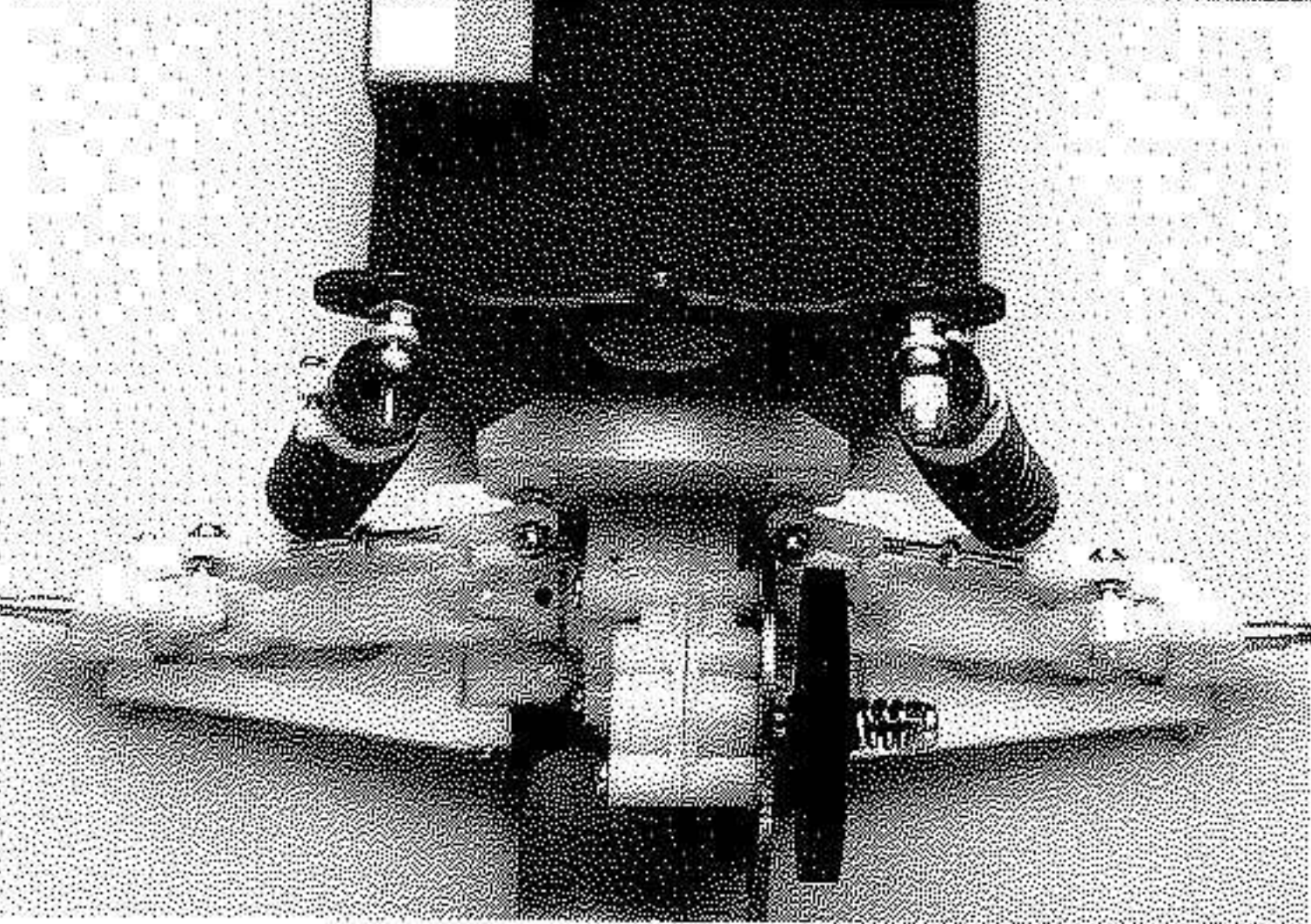

### STEP D-17

On each screw, slide on a nylon spacer, followed by an oil damper, and a nylon oil damper mounting bushing. Now, secure with 3mm locknuts.

**RACER'S TIP:** Do not tighten the locknut so much that it swells the oil damper mounting bushing. The shock should be free to move on the bushing without binding.

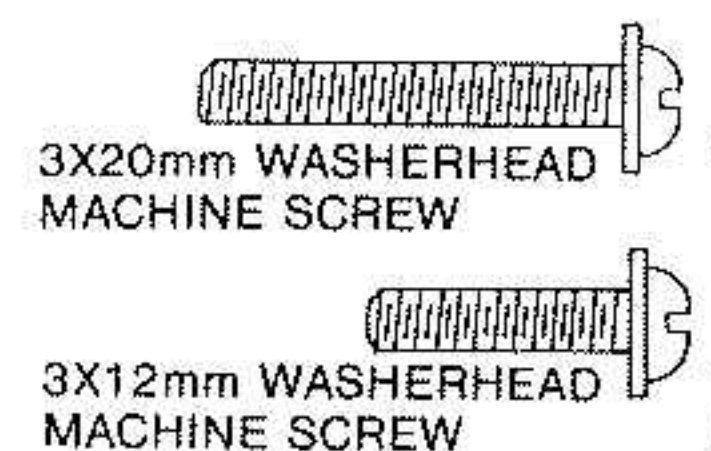
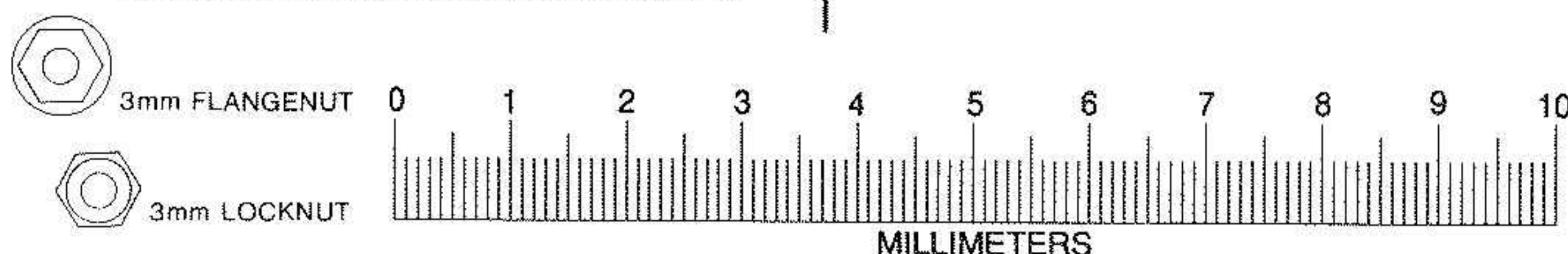

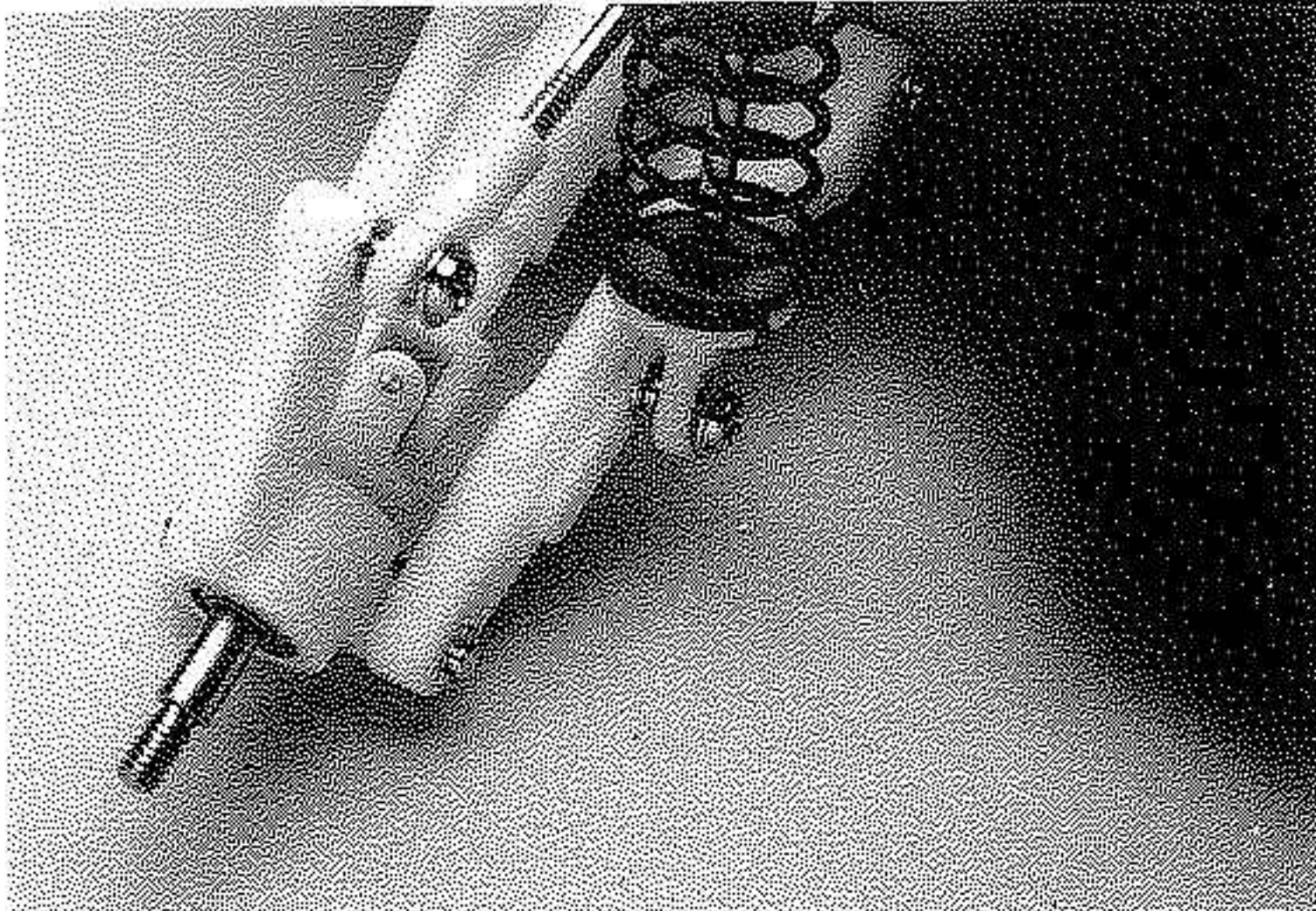

### STEP D-18

Attach the bottom of each rear shock to each the suspension arms with a 3X12mm washerhead machine screw and 3X6mm flat washer. Use the inside hole on each rear suspension arm as a starting point.

**RACER'S TIP:** Refer to the dampening section of the tuning guide for more detailed information about the mounting positions.

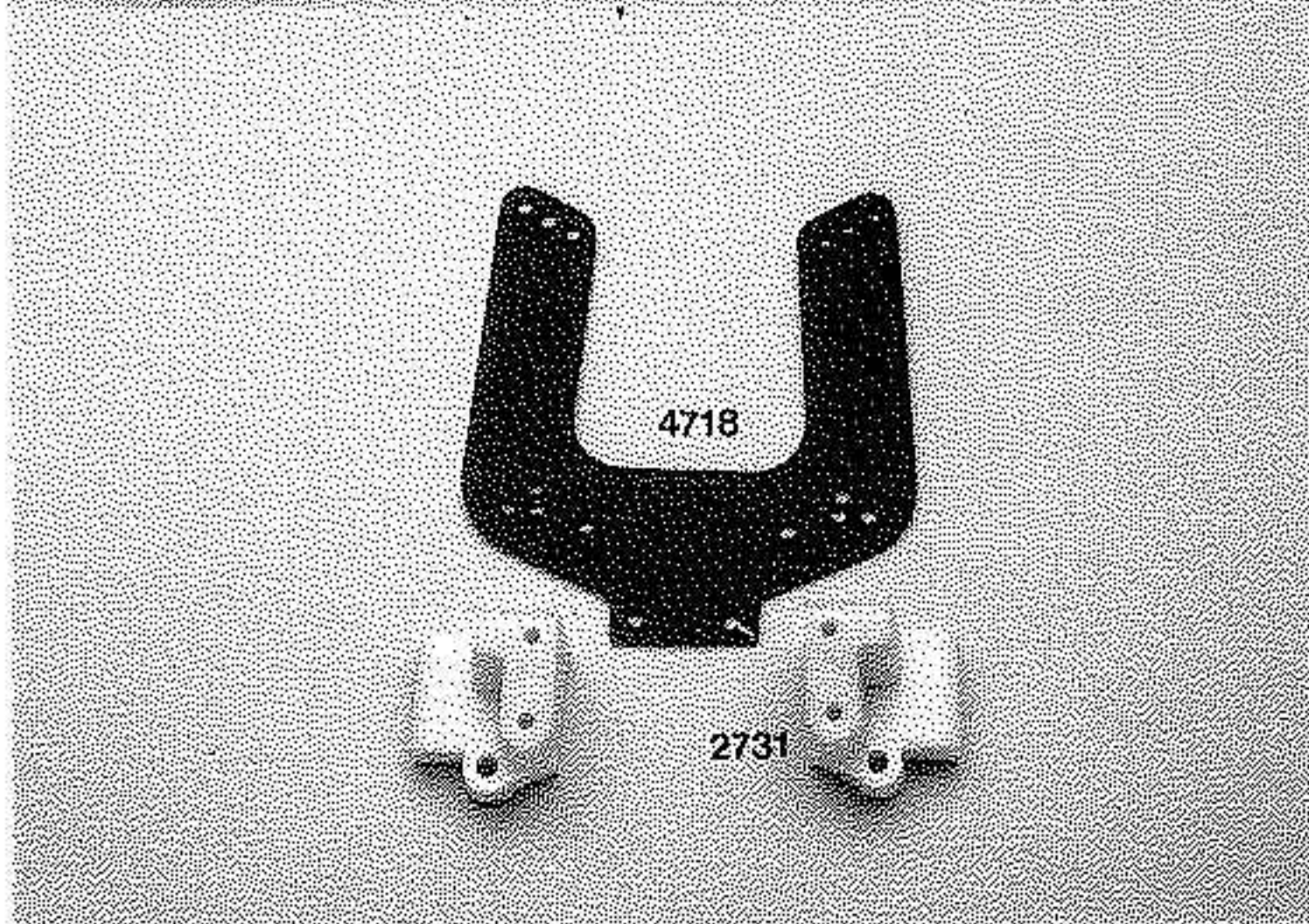

### STEP E-1

Locate the front, left and right suspension arm brackets (2731), and the front shock tower (4718).



### STEP E-2

Fasten the left and right suspension arm brackets to the shock tower with four 3x10mm roundhead self-tapping screws.

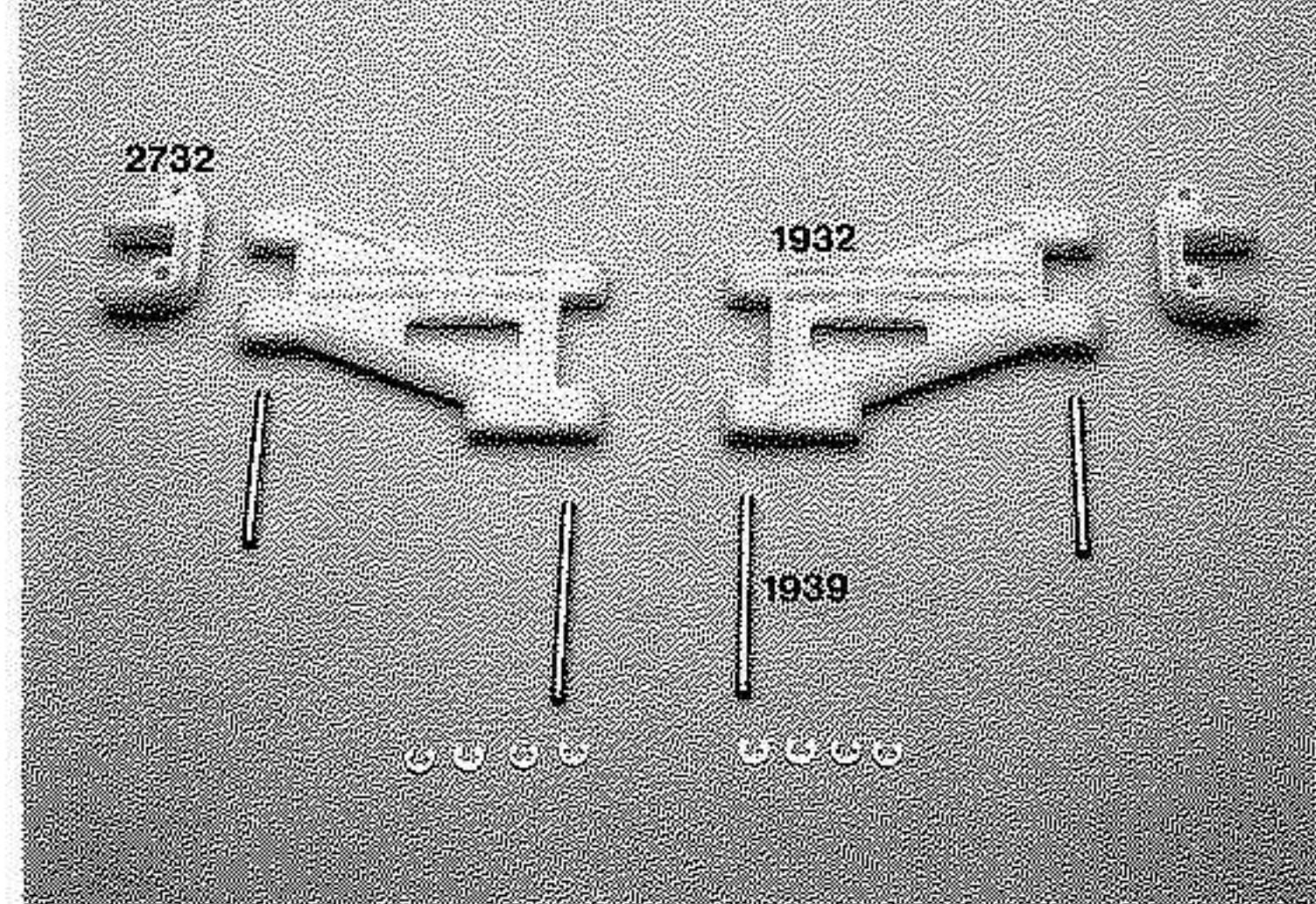

### STEP E-3

Locate the two front suspension arms (1931), the two caster blocks (2732), two 39mm suspension pins (1939), two 31.5mm suspension pins (1939), and eight small E-clips.

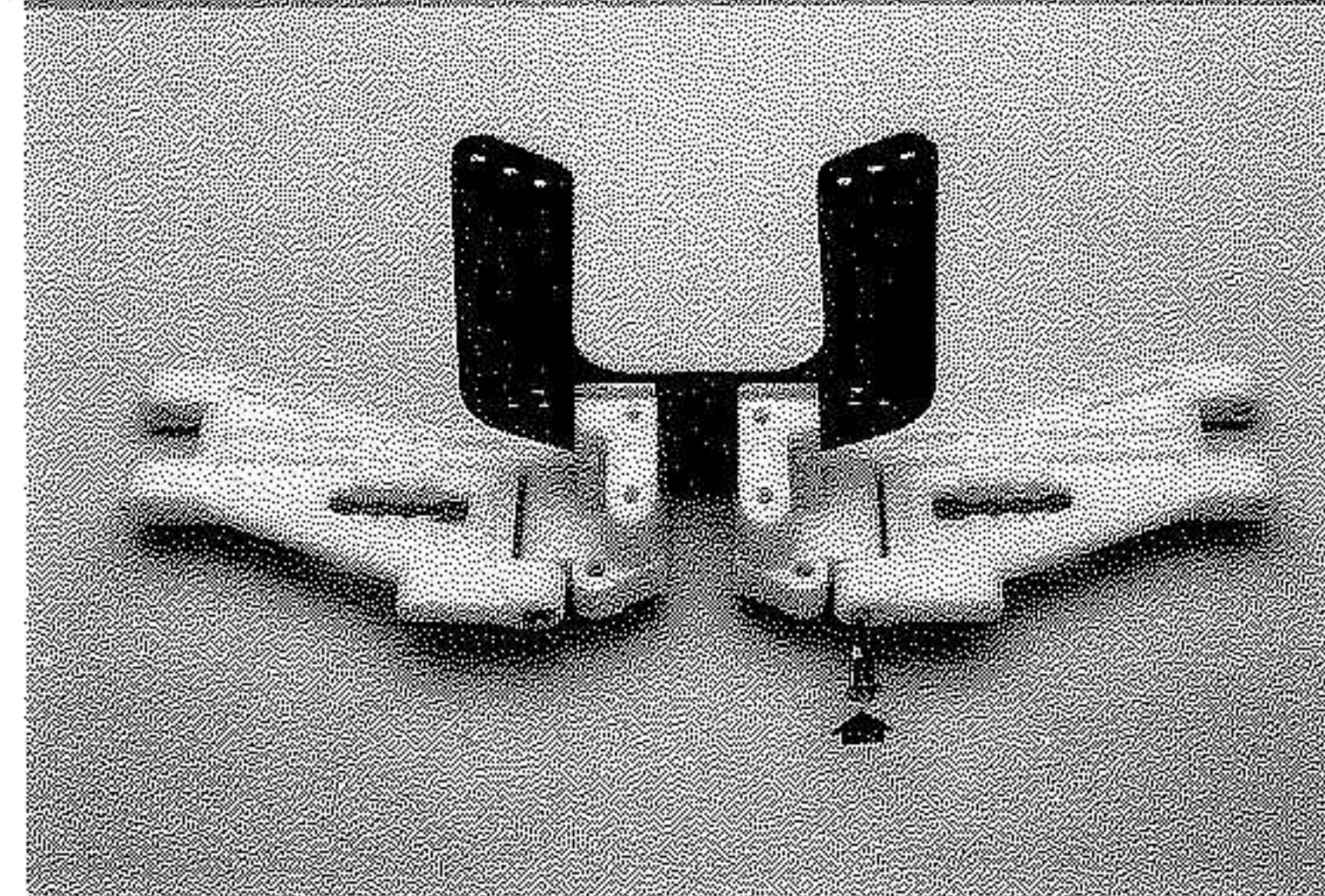

### STEP E-4

Attach the front suspension arms (1931) to the suspension arm brackets by inserting the 39mm suspension pins through the pivot points. Secure with E-clips on both sides. Be careful not to scratch or damage the surface of the pins between the E-clips.

**RACER'S TIP:** Be sure the suspension arms move up and down freely, without binding. Refer to the RACER'S TIP in Step C-13 regarding custom fitting the nylon parts.

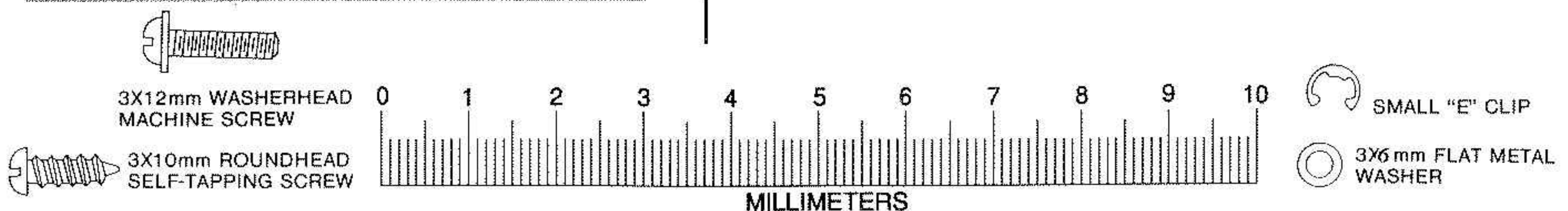

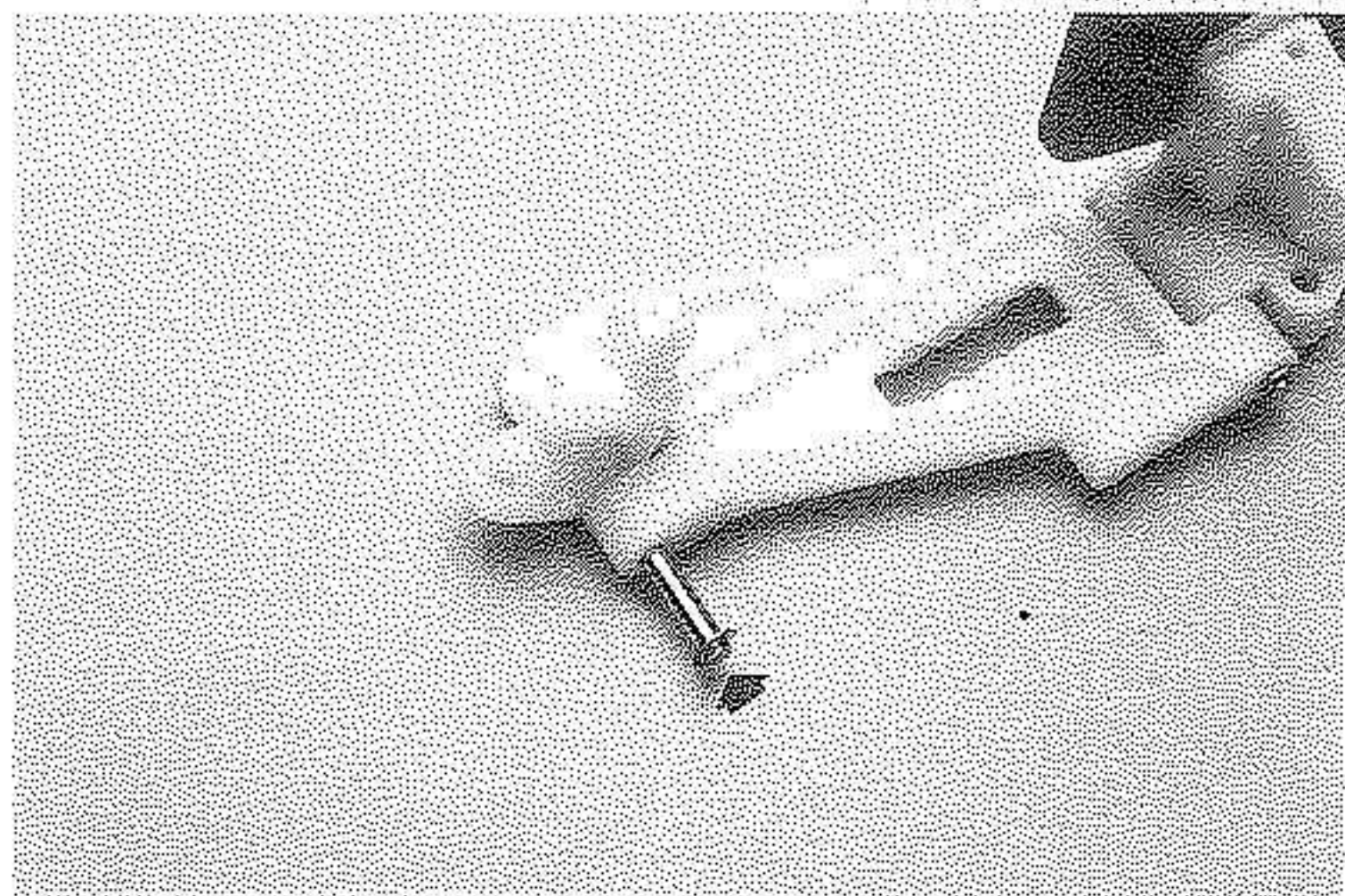

### STEP E-5

Attach the caster blocks (2732) to the front suspension arms by inserting the 31.5mm suspension pins through the pivot points. Secure with E-clips on both sides.

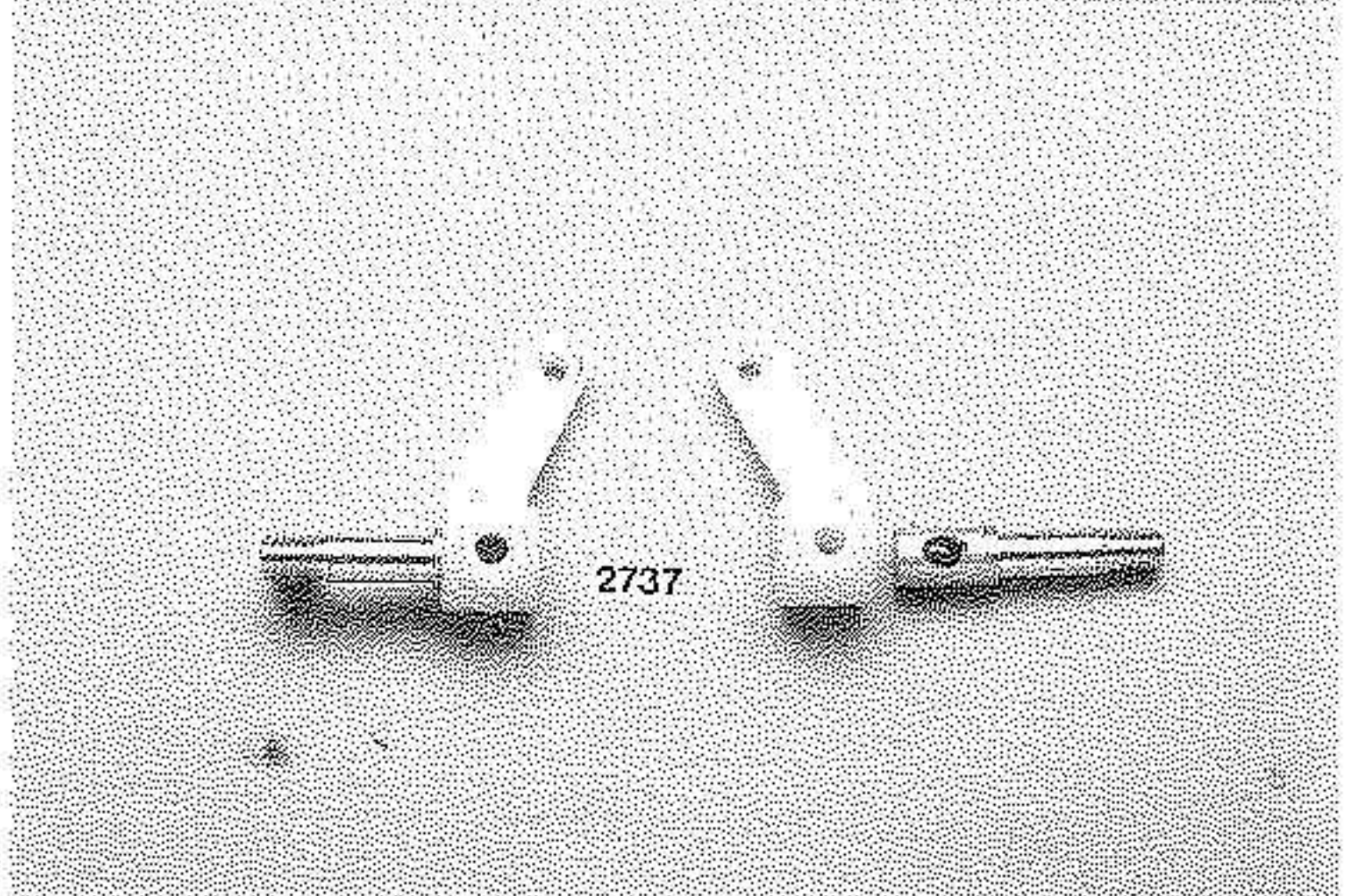

### STEP E-6

Locate the two steering blocks (2737), and the two front wheel spindles (2737). Insert the front spindle into the steering block so that the hole in the spindle lines up with the holes in the top and bottom of the steering block. Repeat for the other steering block.

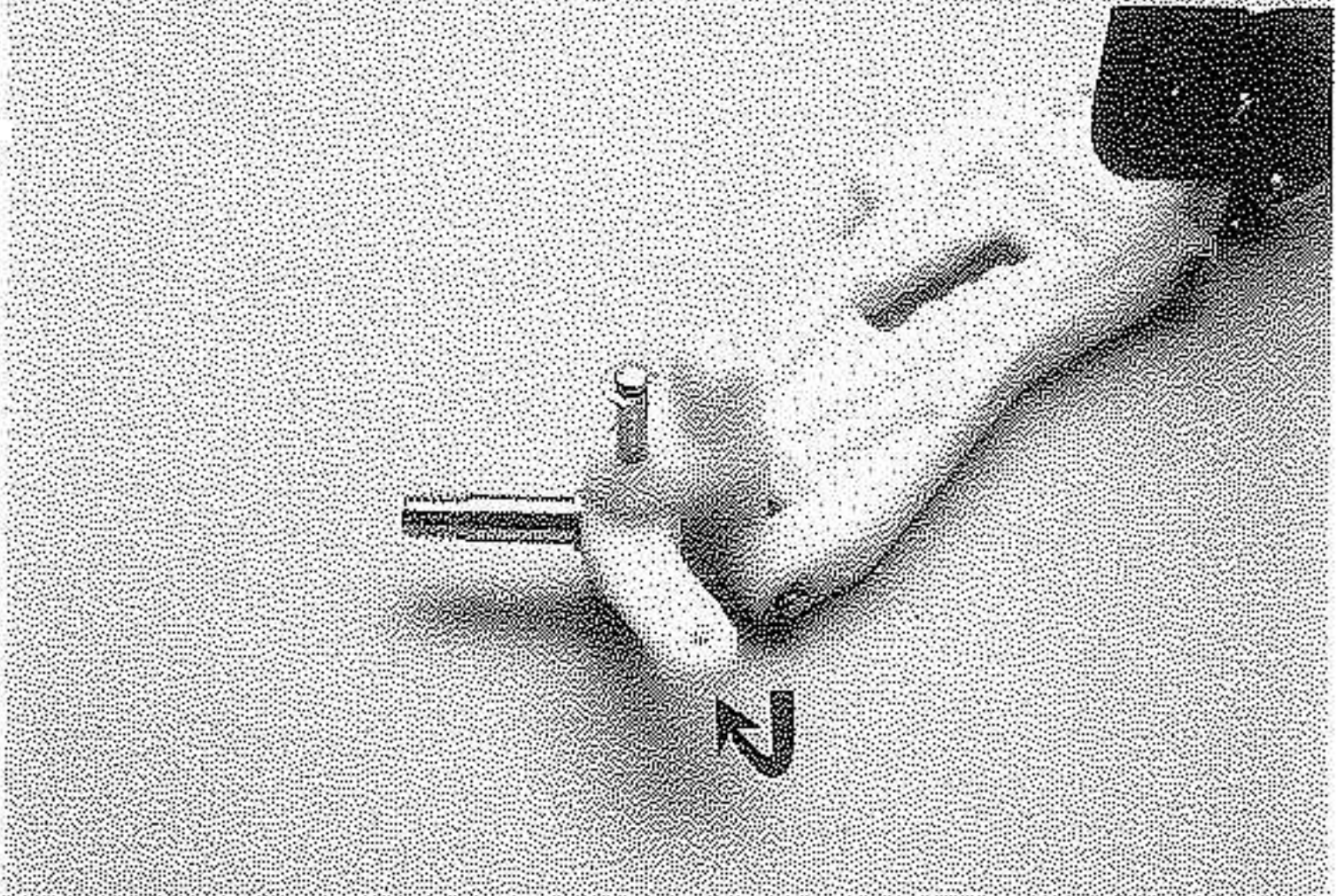

### STEP E-7

Locate the two 23mm suspension pins (the two shortest ones, 1939) and four small E-clips. Note that there is a left and right steering block. Attach the steering blocks to the caster blocks as shown, by inserting the 23mm suspension pins through the pivot points. If the pins are hard to push in, make sure the holes in the spindle are correctly lined up with the holes in the steering block. Secure the suspension pins with E-clips on both sides. The countersunk side of the steering block should face down (arrow).

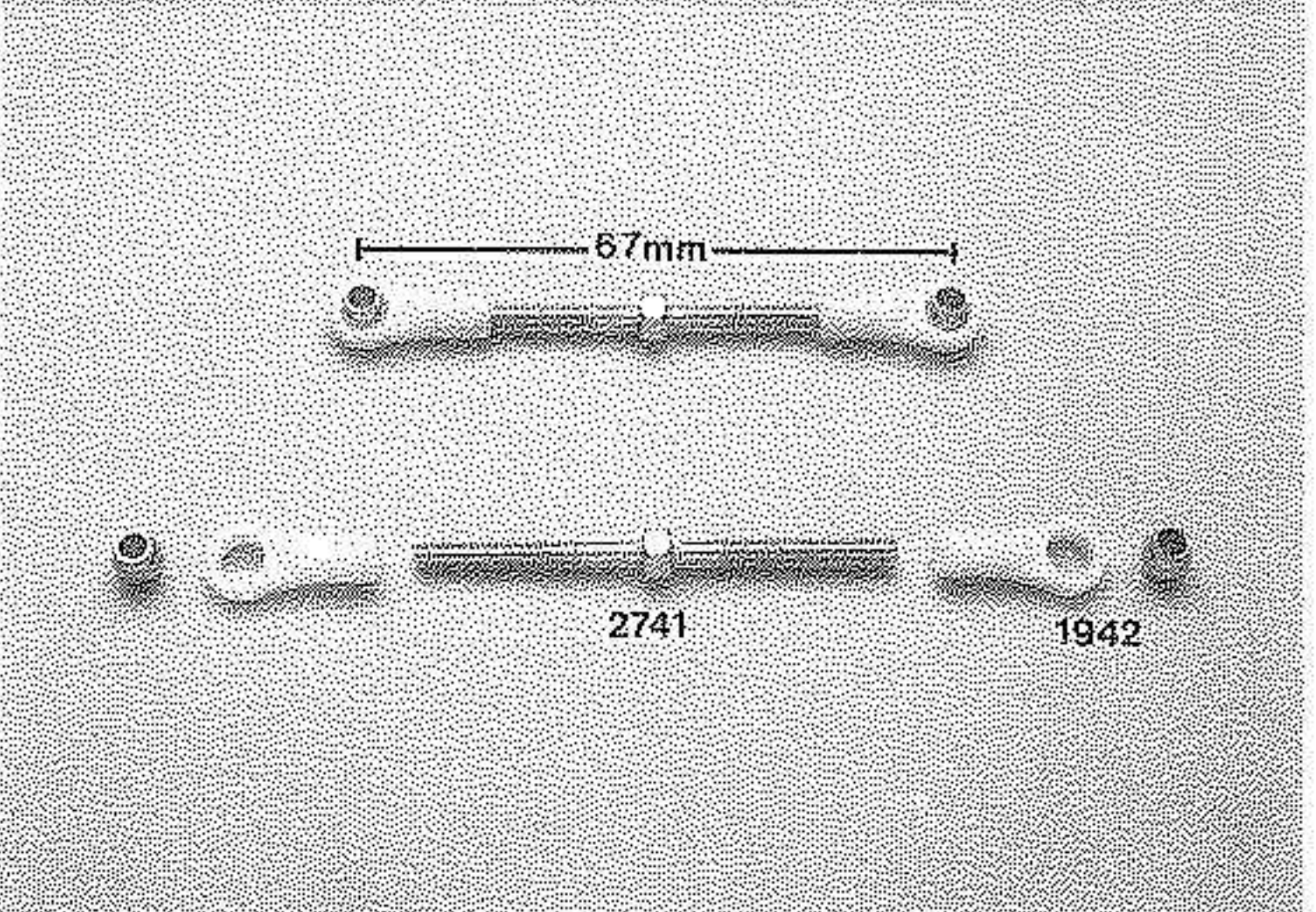

### STEP E-8

Locate the two front 54mm turnbuckles (2741), four rod ends (1942), and four hollow ball connectors (1942). Note that the cone side of the adjusting nut denotes the backwards, left-hand threads. Screw on the rod ends an equal number of turns, so that each turnbuckle has a center-to-center distance of 67mm. Snap in the hollow ball connectors.

**RACER'S TIP:** Do not oil the hollow ball connectors in the rod ends. The oil will attract dirt and cause the connectors to bind.

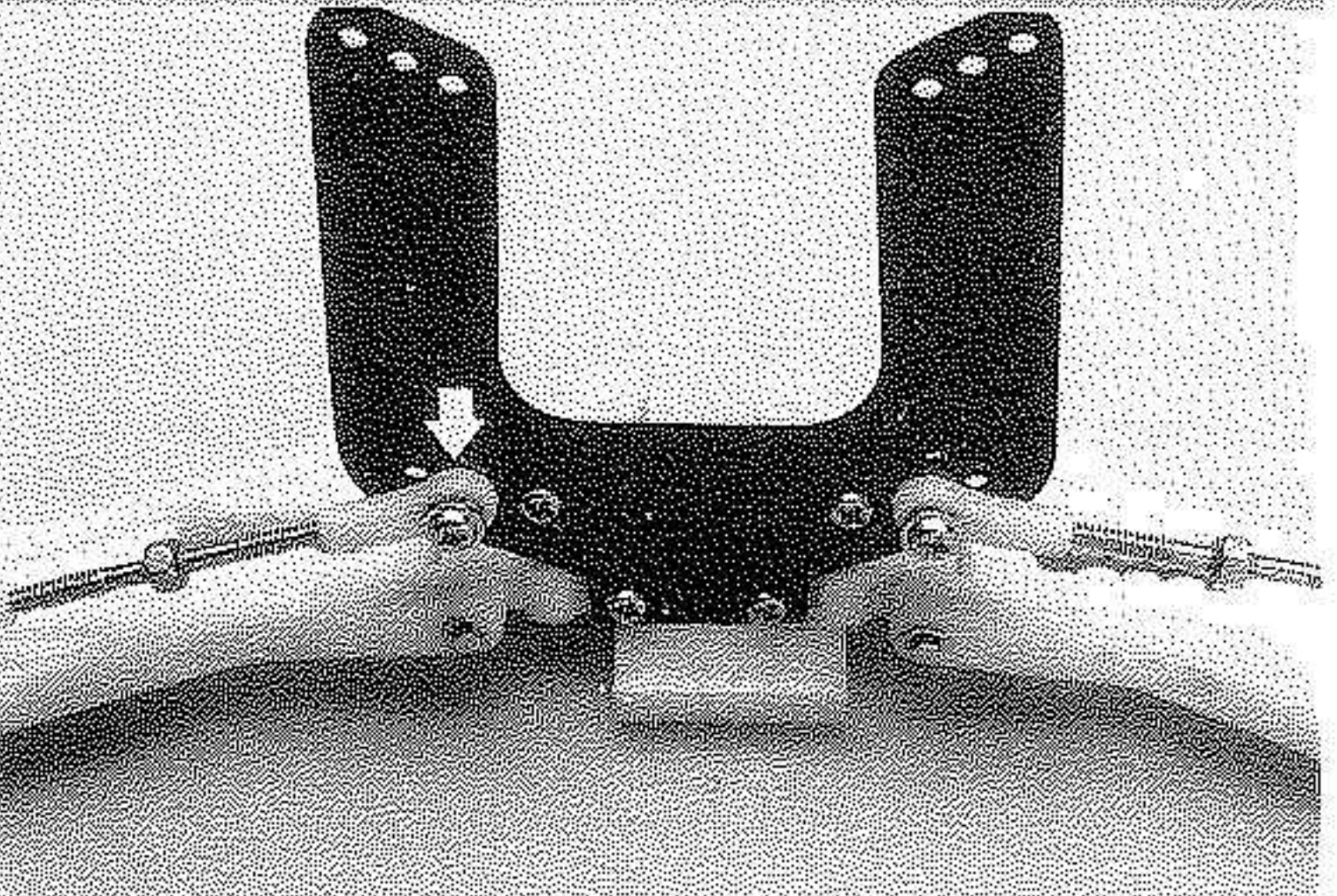

### STEP E-9

Notice on your front end assembly, the graphite shock tower has three holes in each bottom corner. Of the three holes, mount the front turnbuckles in the lower inside holes on each side. Use 3X15mm washerhead machine screws, 3x6mm flat metal washers, and 3mm locknuts to mount the turnbuckles. Put the 3X6mm metal washers between the hollow ball connectors and the shock tower (arrow).

**RACER'S TIP:** The suggested mounting holes are located specifically for use with the factory parts. If you use other aftermarket caster blocks in the future, you may have to use some of the other holes. Refer to the Tuning Guide for a more detailed explanation of the mounting points.

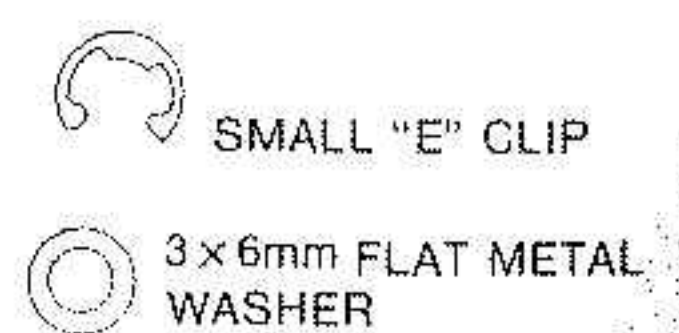
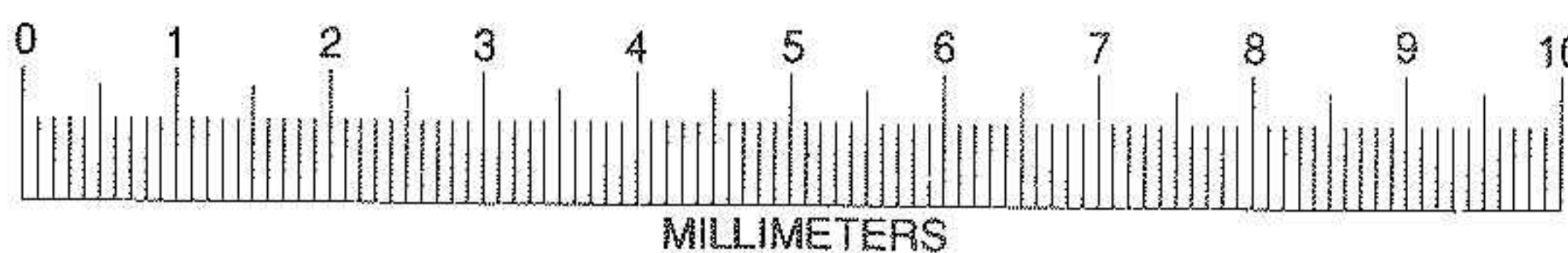

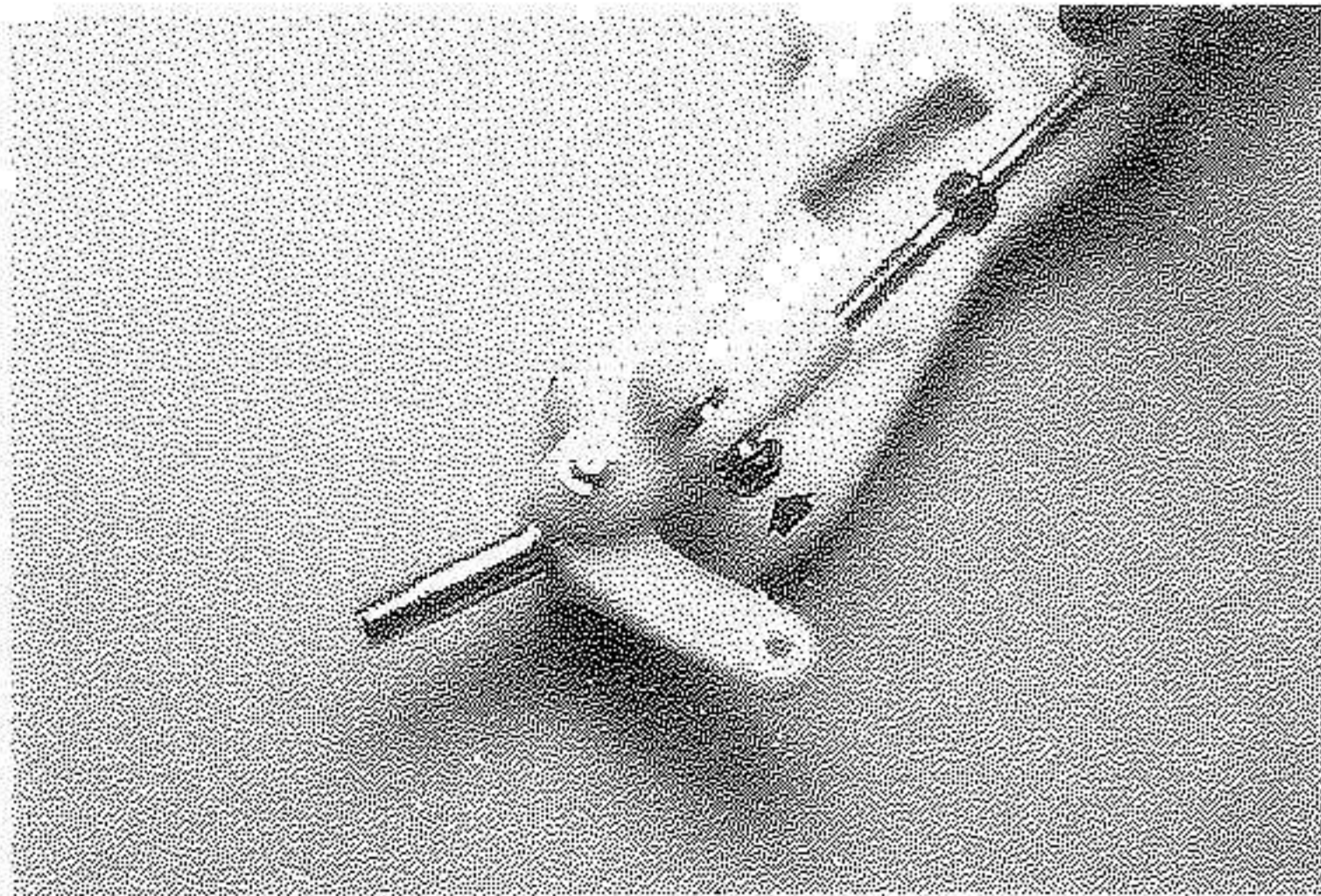

### STEP E-10

Mount the front turnbuckles to the caster blocks with 3X12mm washerhead machine screws. Put the screw through the hollow ball connector, slide a 3X6mm metal washer over the screw, and then screw it into the caster block. Repeat for the other side.

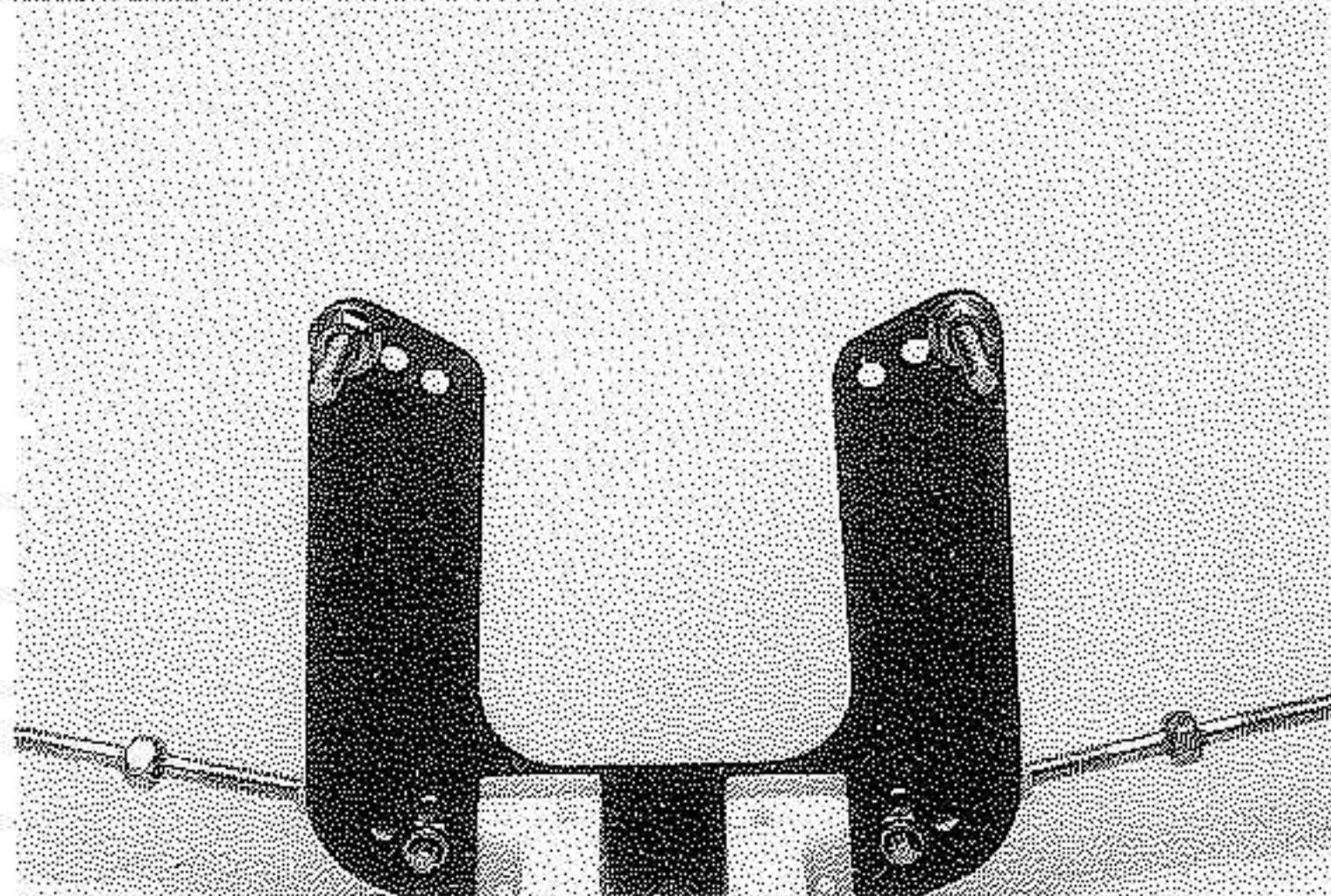

### STEP E-11

Locate two 3X20mm washerhead machine screws, and two 3mm flange nuts. Of the three upper shock mounting holes on each side of the shock tower, use the outer mounting holes. Insert a 3X20mm washerhead screw through the backside of the front shock tower and secure it with a 3mm flange nut. Repeat for the other side.

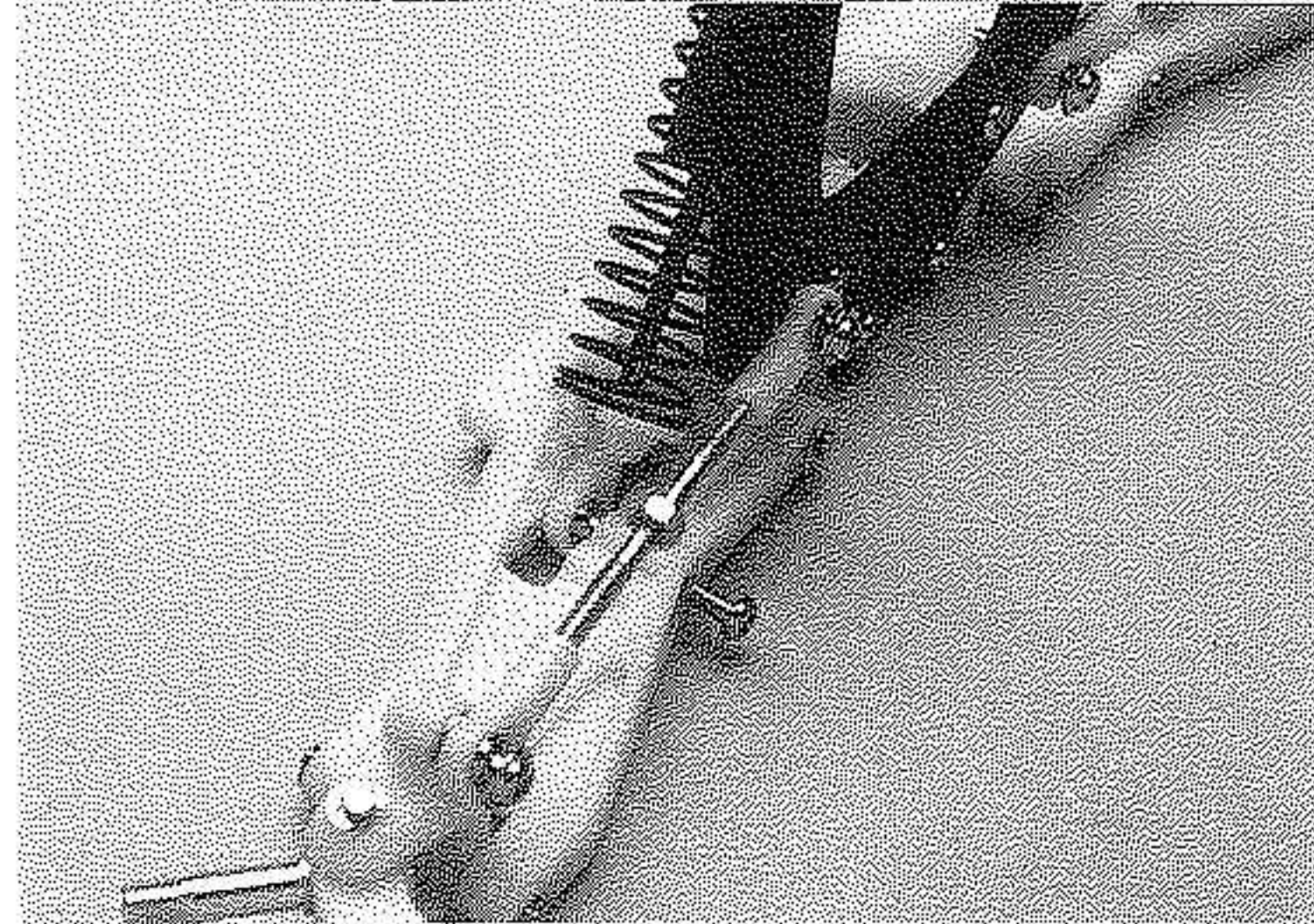

### STEP E-12

Push the bottom of a front shock through the front suspension arm. Attach the shock by inserting a 3X24mm roundhead machine screw through the backside of the suspension arm. Use the center hole on the suspension arm. Repeat for the other front shock.

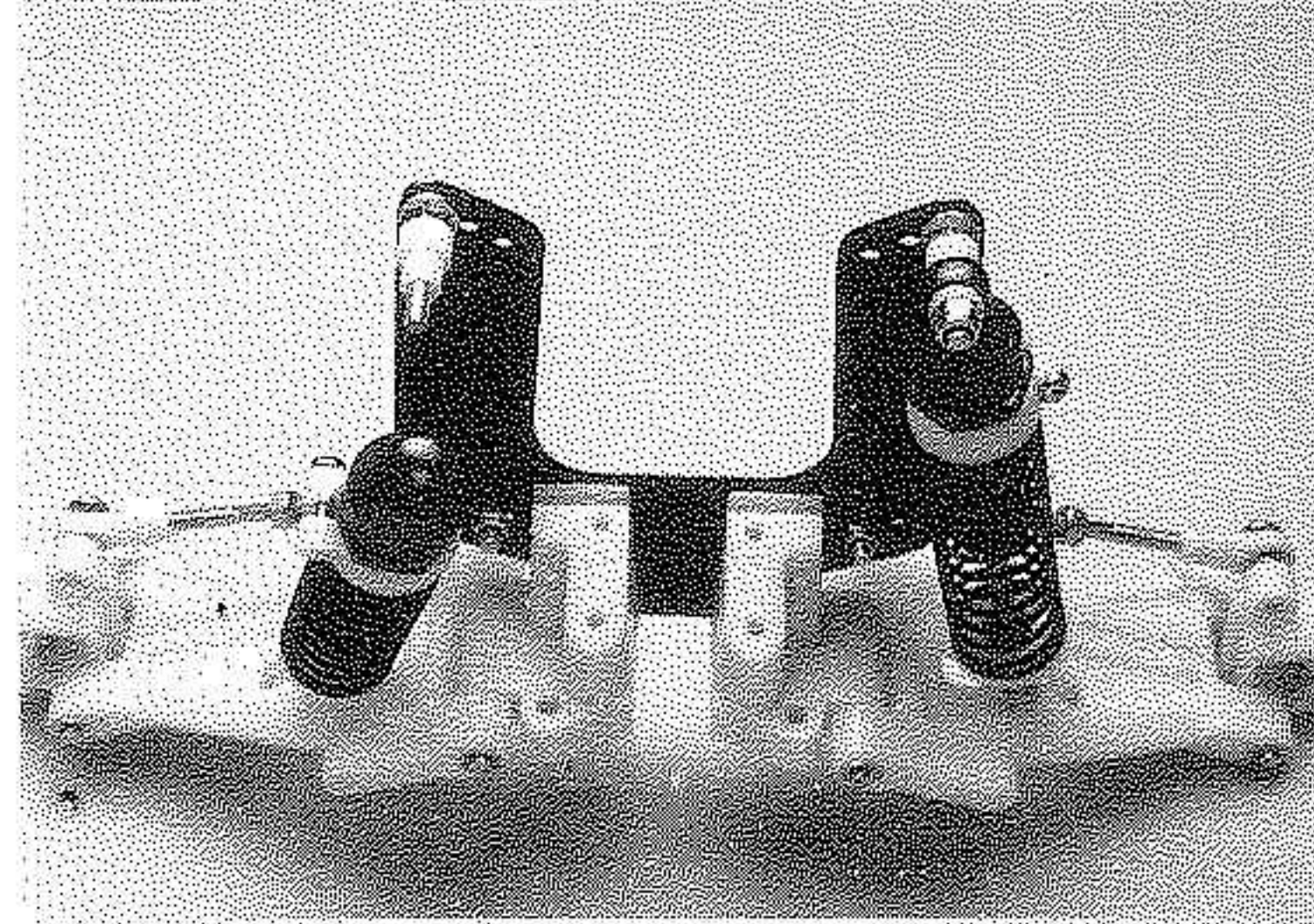

### STEP E-13

Slide on a nylon oil damper bushing (1662), followed by a front shock, and a 3X5X6mm nylon washer (1662), over the 3X20mm screw. The nylon oil damper bushings and washers are leftover parts from Bag D. Secure this assembly with a 3mm locknut. Repeat for the other side.

**RACER'S TIP:** Do not over-tighten the locknut and swell the oil damper mounting bushing. The shocks should be free to turn around the mounting bushing without binding.

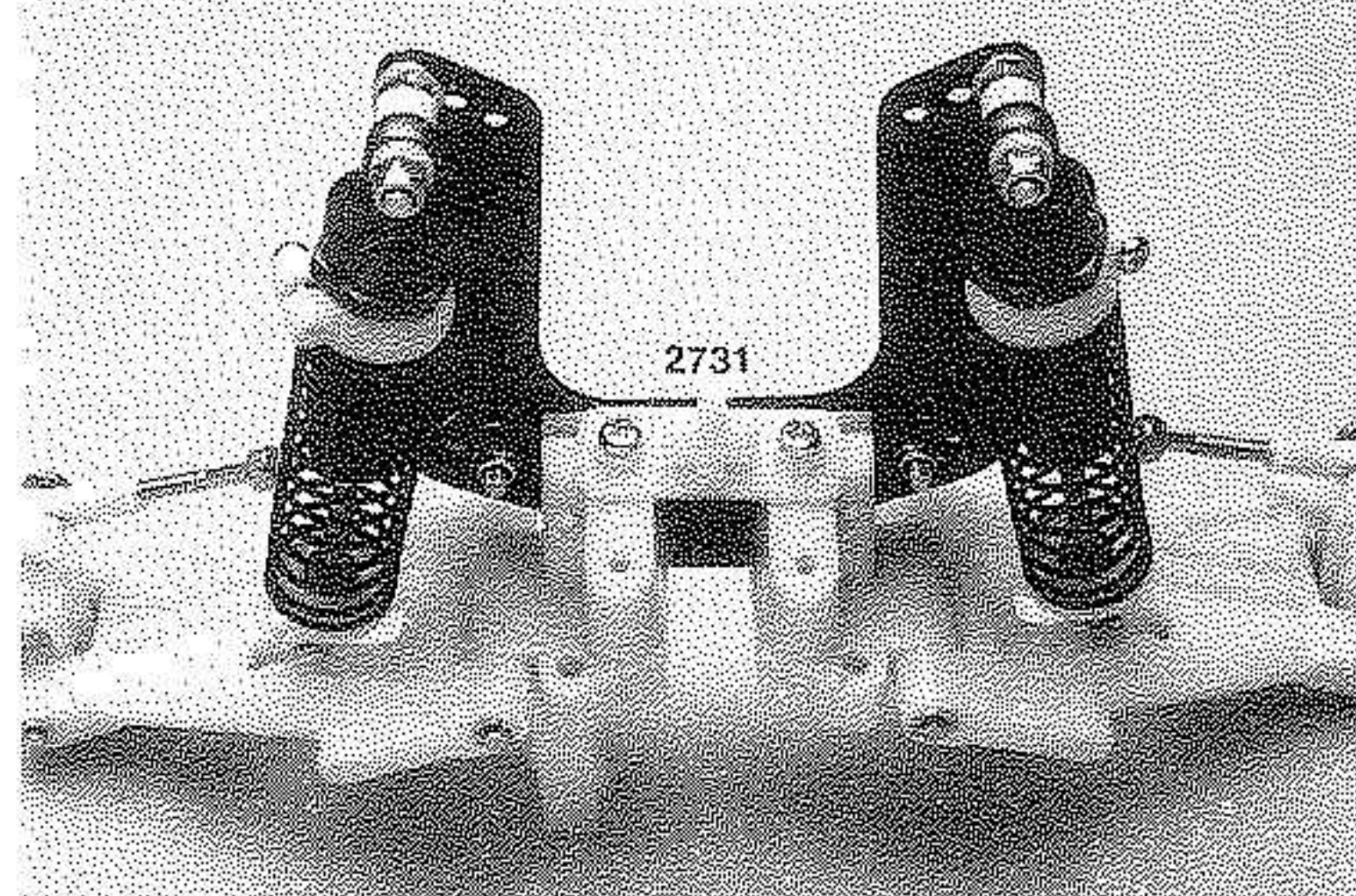

### STEP E-14

Locate the front body mount (2731) and two 3x10mm roundhead self-tapping screws. Fasten the body mount to the front suspension arm mounts with the two self-tapping screws as shown.

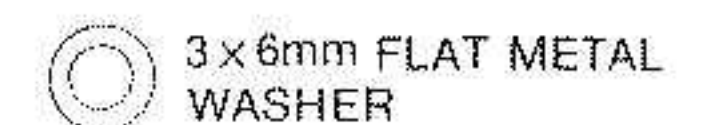
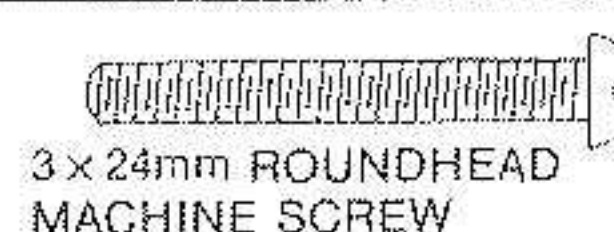
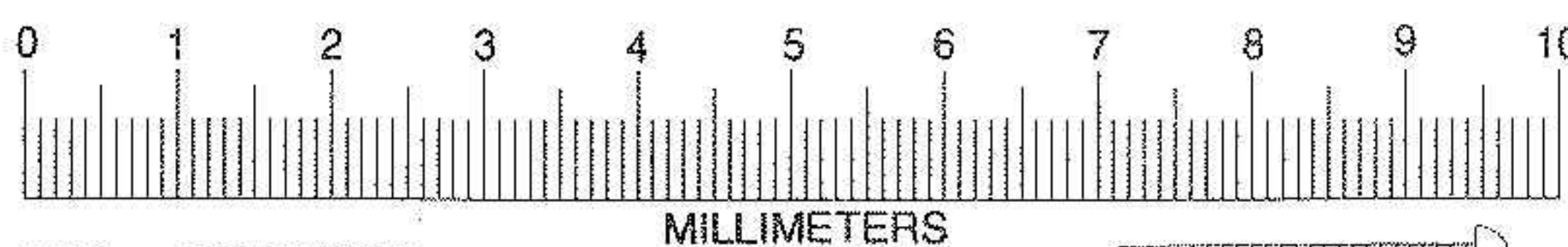
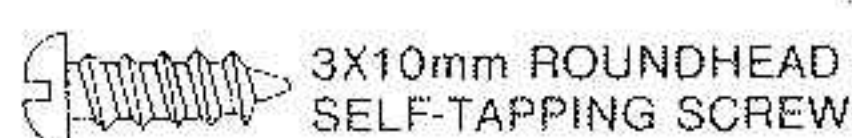
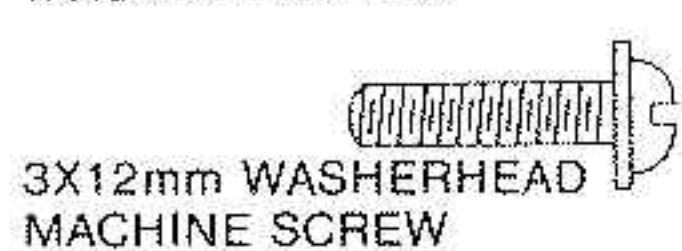
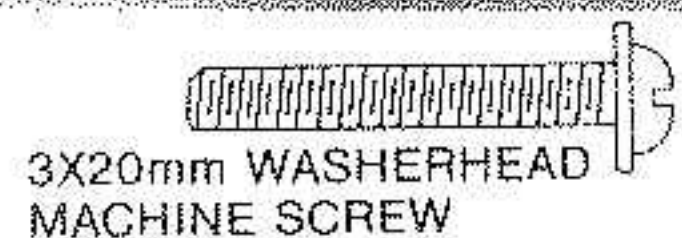

## BAG F: STEERING

### STEP F-1

Locate the two aluminum pivot bushings (1944) and two 3X8mm countersunk machine screws.



### STEP F-2

Fasten the two aluminum pivot bushings to the chassis by using the two 3X8mm countersunk machine screws inserted from the bottom. Tighten them securely. DO NOT grip the main surface of the bushing with pliers (arrow).

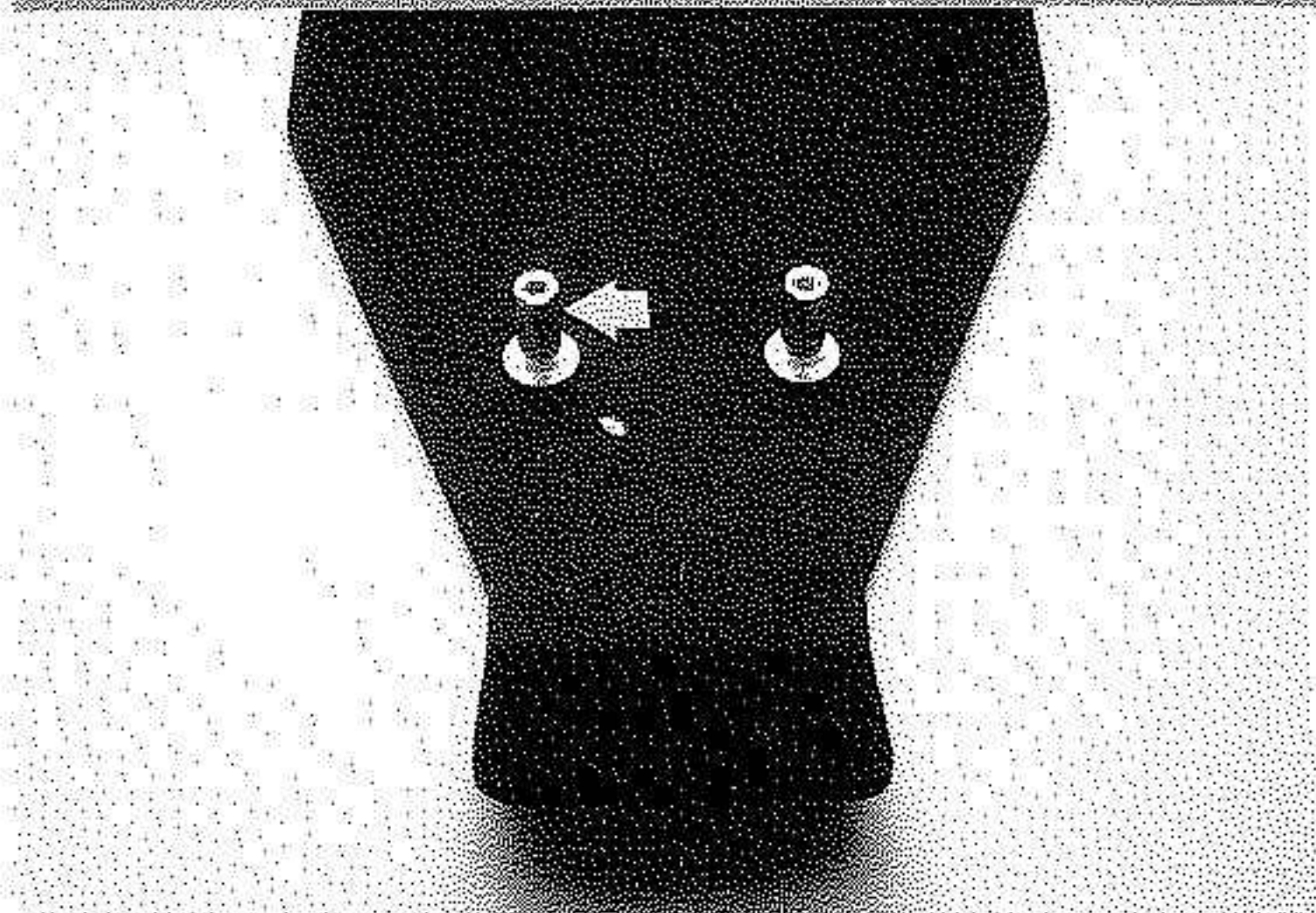

### STEP F-3

Locate the two steering bellcranks (1943), the fiberglass drag link (2738), two 3X8mm shoulder screws (2738), and two 3x6mm flat metal washers.

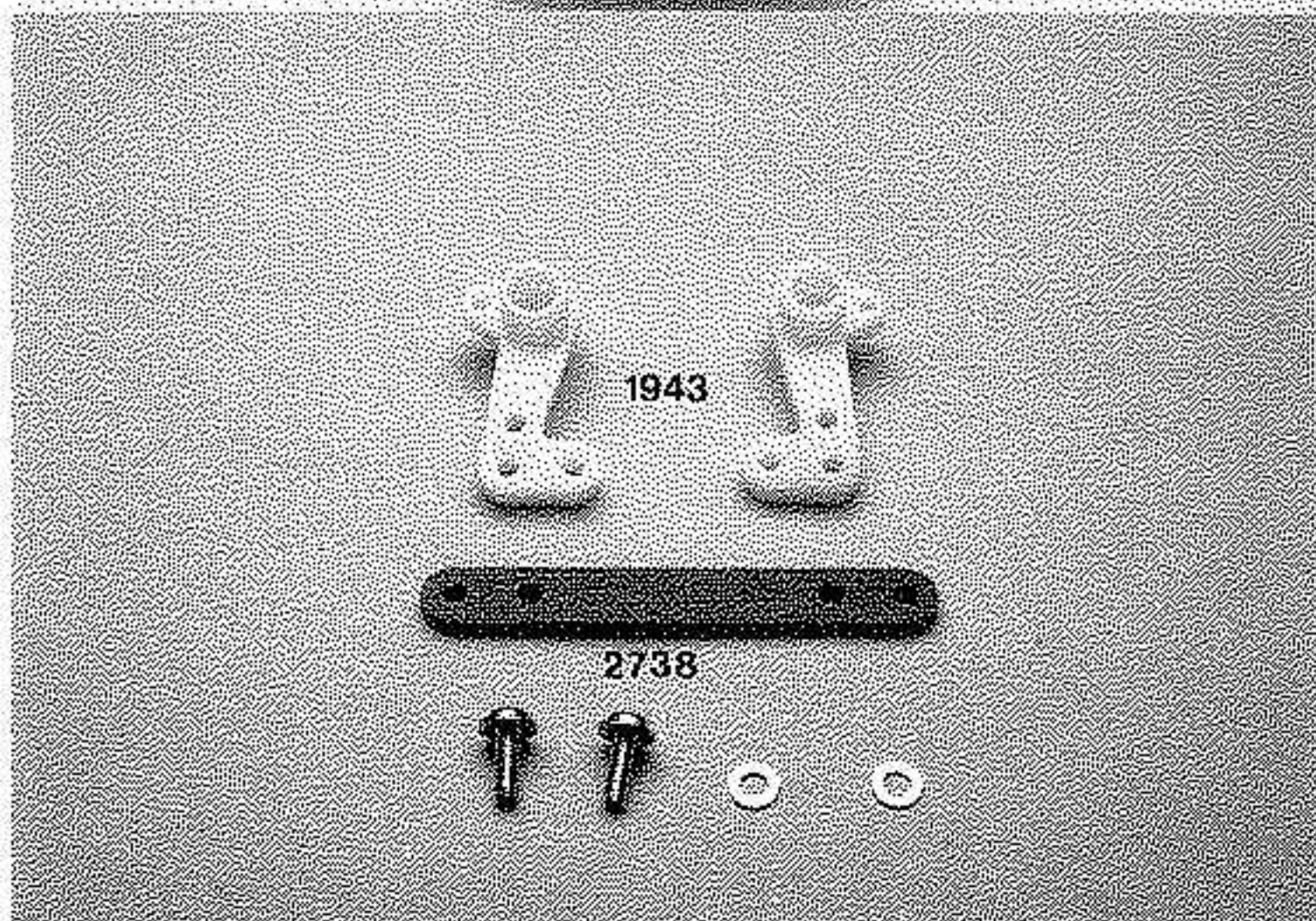

3X12mm SHOULDER SCREW

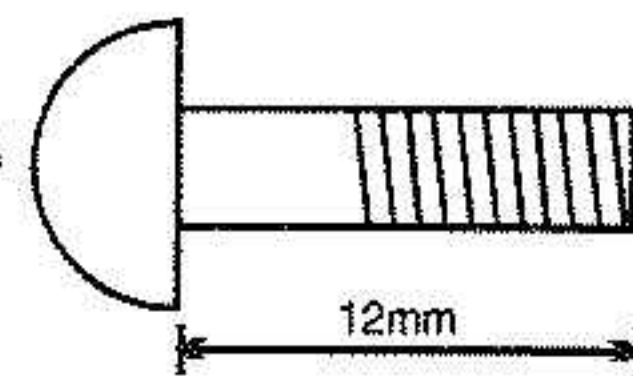

### STEP F-4

Fasten the drag link to the bellcranks, as shown, with the 3x8mm shoulder screws inserted underneath the drag link. The 3x6mm metal washer is inserted between the drag link and the bellcranks. Tighten the screws until the assembly has no slop in it yet, still operates freely with minimal friction. Set this assembly aside.

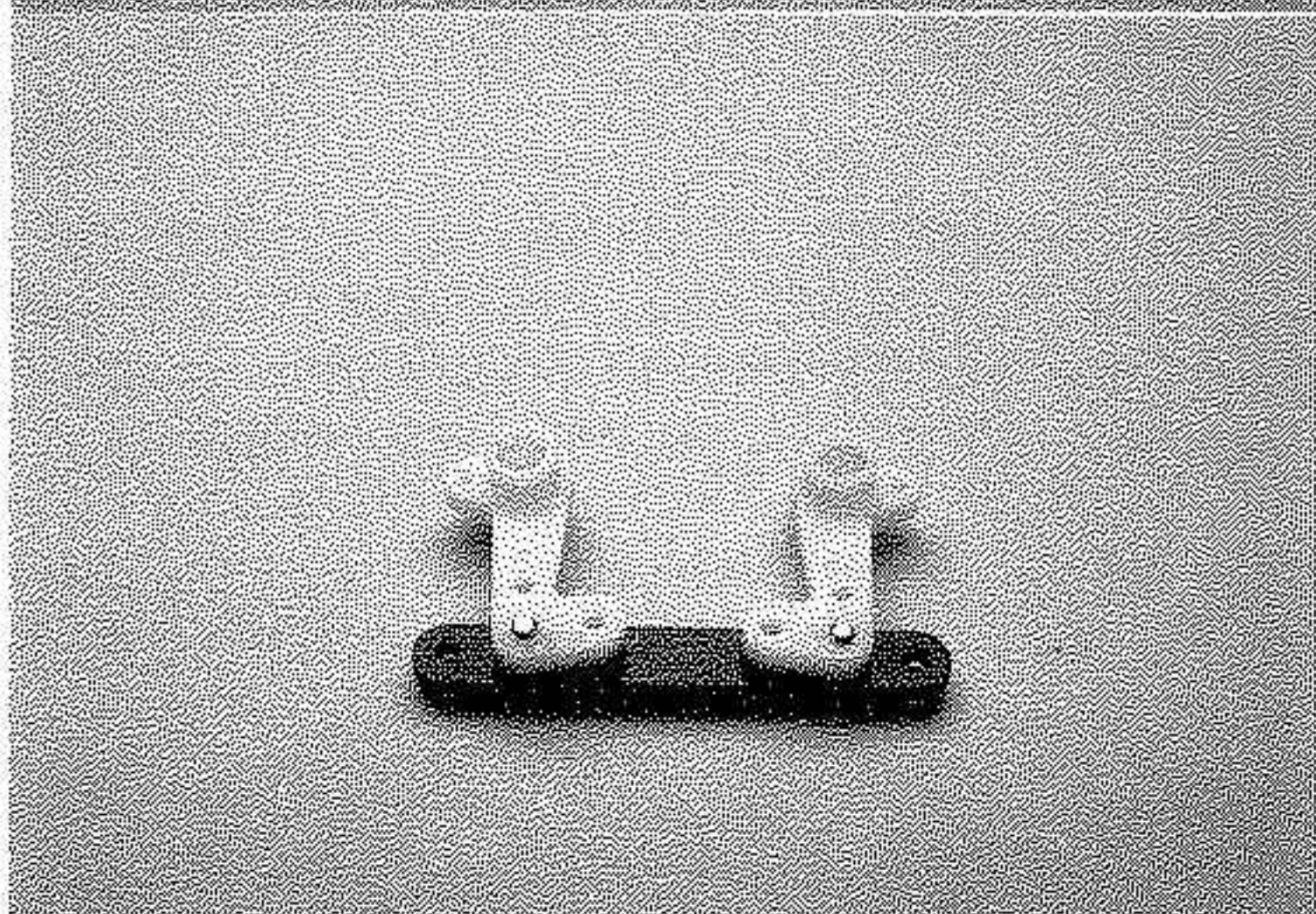

### STEP F-5

Locate the two 54mm turnbuckles (tie rods) (2741), four long rod ends (1942), and four hollow ball connectors (1942). Screw the rod ends on an equal number of turns until you have a center-to-center distance of 68mm. Snap in the hollow ball connectors.

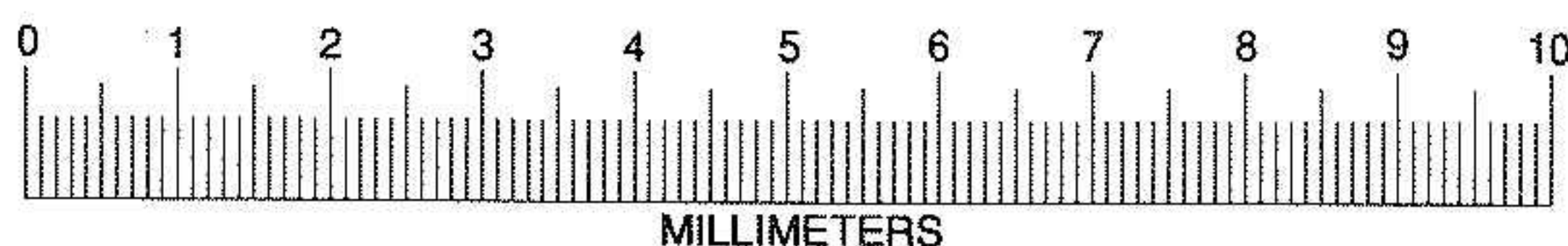
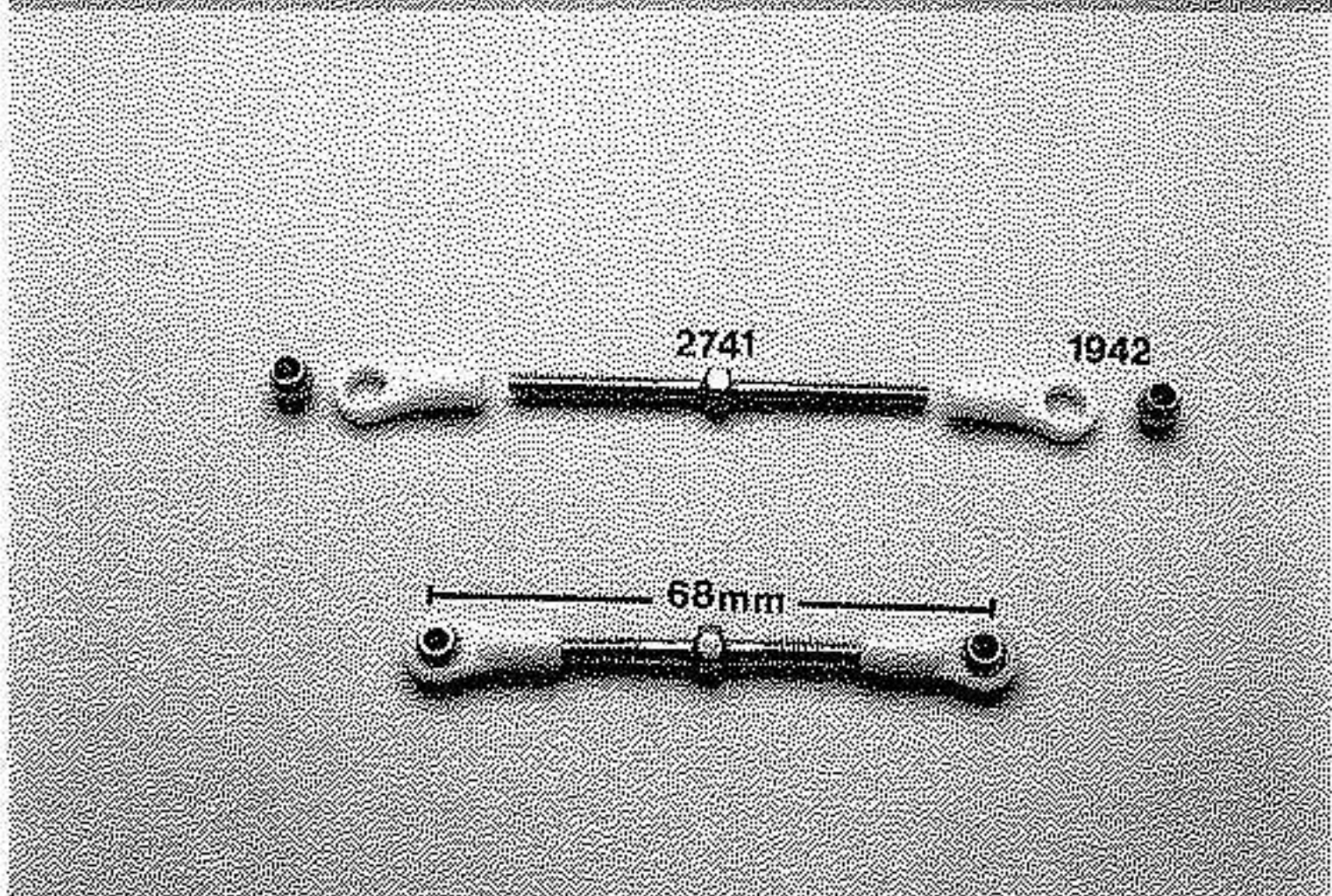

3x8mm COUNTERSUNK MACHINE SCREW



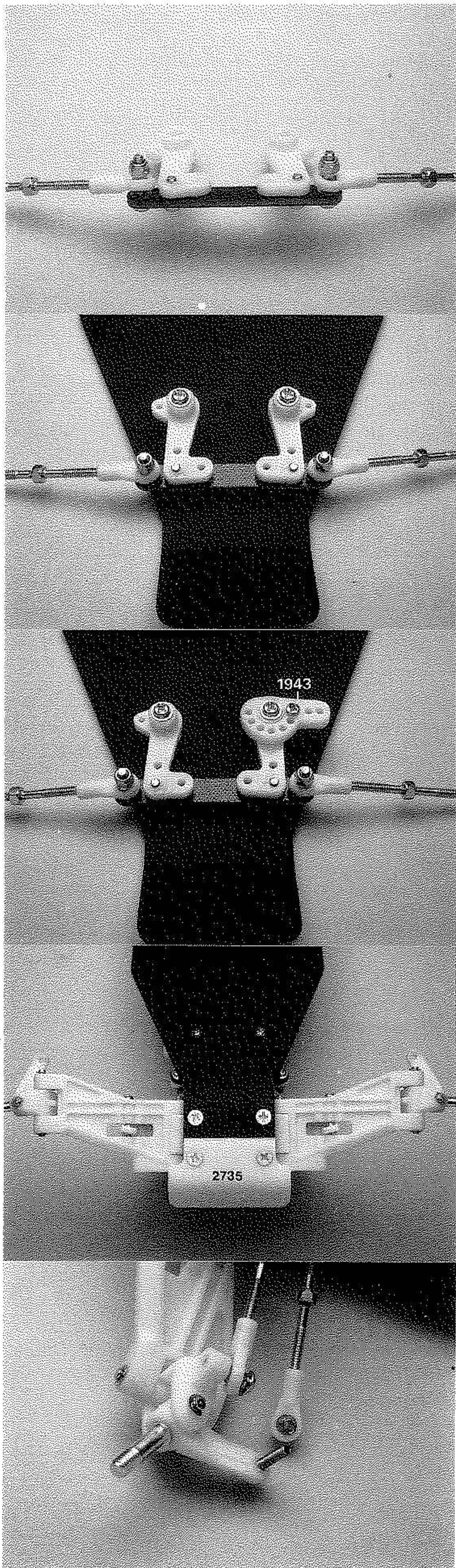

### STEP F-6

Fasten the tie rods to the drag link as shown with two 3x15mm washerhead machine screws, two 3x6mm flat metal washers, and two 3mm locknuts. Insert the 3x6 washer in between the drag link and the hollow ball connector.

### STEP F-7

Slide the bellcrank and drag link assembly over the pivot bushings and secure them with the two 3X6mm washerhead machine screws. If the bellcranks do not turn smoothly on the bushings, there may be some mold flashing around the inside edges where the bellcranks slide over the bushings. Carefully remove this flashing with an X-acto knife.

### STEP F-8

Position the radius arm (1943) over the left bellcrank as shown. Secure it with the 2.6X10mm roundhead self-tapping screw.

### STEP F-9

Locate the front bumper (2735) and four 4X12mm aluminum countersunk machine screws (1948). Position the front end assembly and bumper onto the front of the graphite chassis. Secure this assembly from the bottom with the four 4X12mm aluminum countersunk screws.

### STEP F-10

Insert a 3X15mm countersunk machine screw through the bottom of the steering block. Repeat for the opposite side.

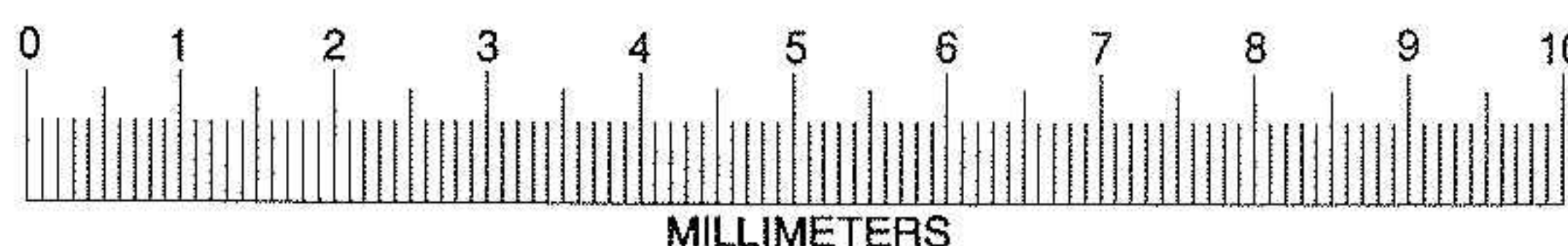
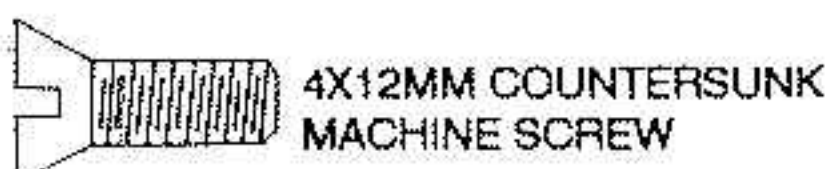

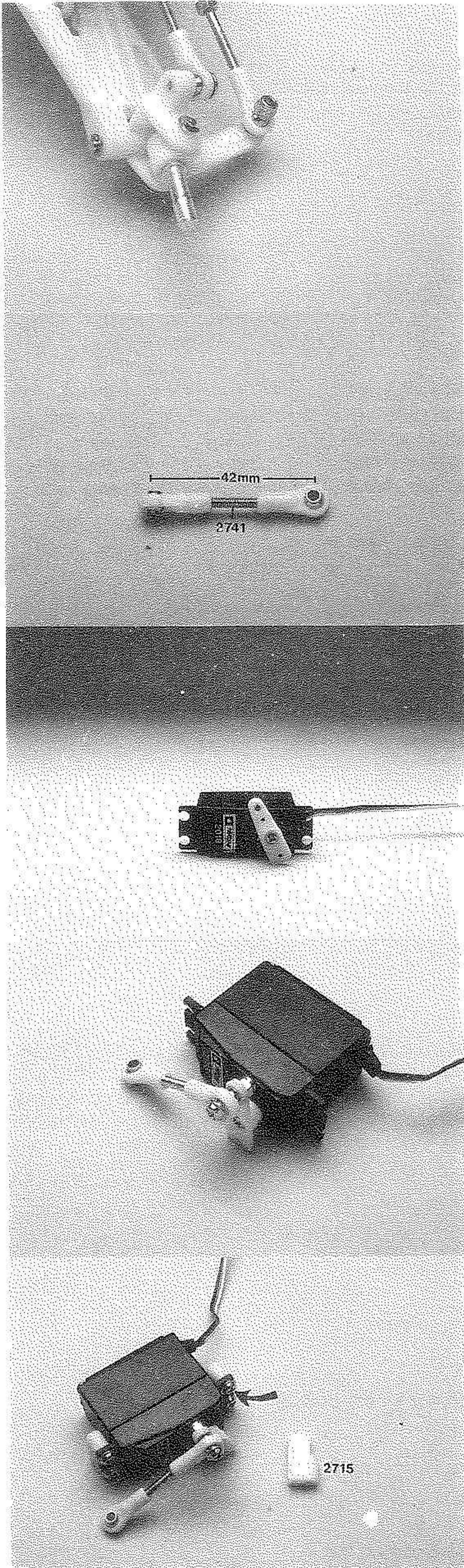

### STEP F-11

Place a 3X6mm flat metal washer over the 3X15mm screw followed by the tie rod end. Secure this assembly with a 3mm locknut. Repeat for the opposite side.

### STEP F-12

Locate the 28mm threaded rod (2741). Screw a rod end onto each side, until you have a center to center distance of 42mm. Snap the hollow ball connectors into the rod ends. This assembly will now be referred to as the steering rod.

### STEP F-13

Locate your steering servo (not included in this kit). Your radio system should have come with a variety of servo arms. Select a servo arm or servo saver (not included), which will give you a distance of approximately 16-19mm between the center of the servo shaft and the outside mounting hole on the arm. Follow the instructions in the front of this manual to center your steering servo. Without moving the servo shaft, place the servo saver, or servo arm, onto the shaft at an angle of approximately 15-20 degrees off center. Secure the servo arm to the servo shaft with the shortest possible 3mm self-tapping screw (see your servo manufacturer's instructions).

### STEP F-14

Fasten the steering rod to the servo arm with a 3x12mm washerhead machine screw, a 3x6mm flat metal washer, and a 3mm locknut. Insert the 3x6 washer in between the servo arm and the hollow ball connector.

### STEP F-15

Locate the two servo mounts (2715) and four 3x6mm washerhead self-tapping screws. Fasten the mounts to the backside of the servo ears with the four self-tapping screws.

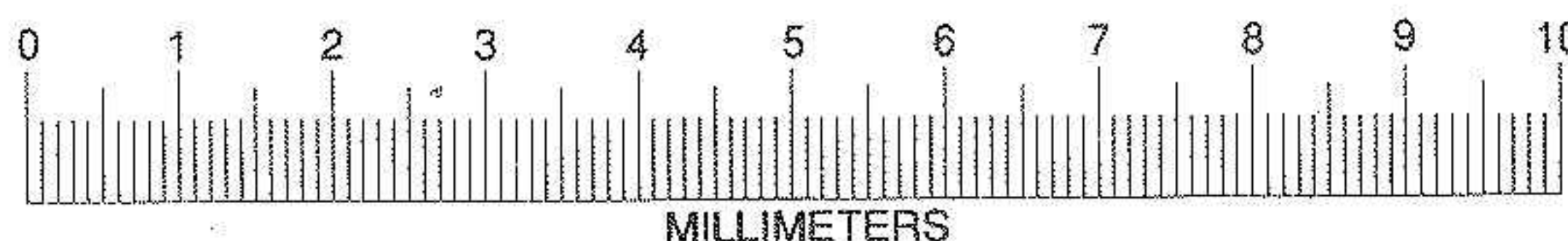

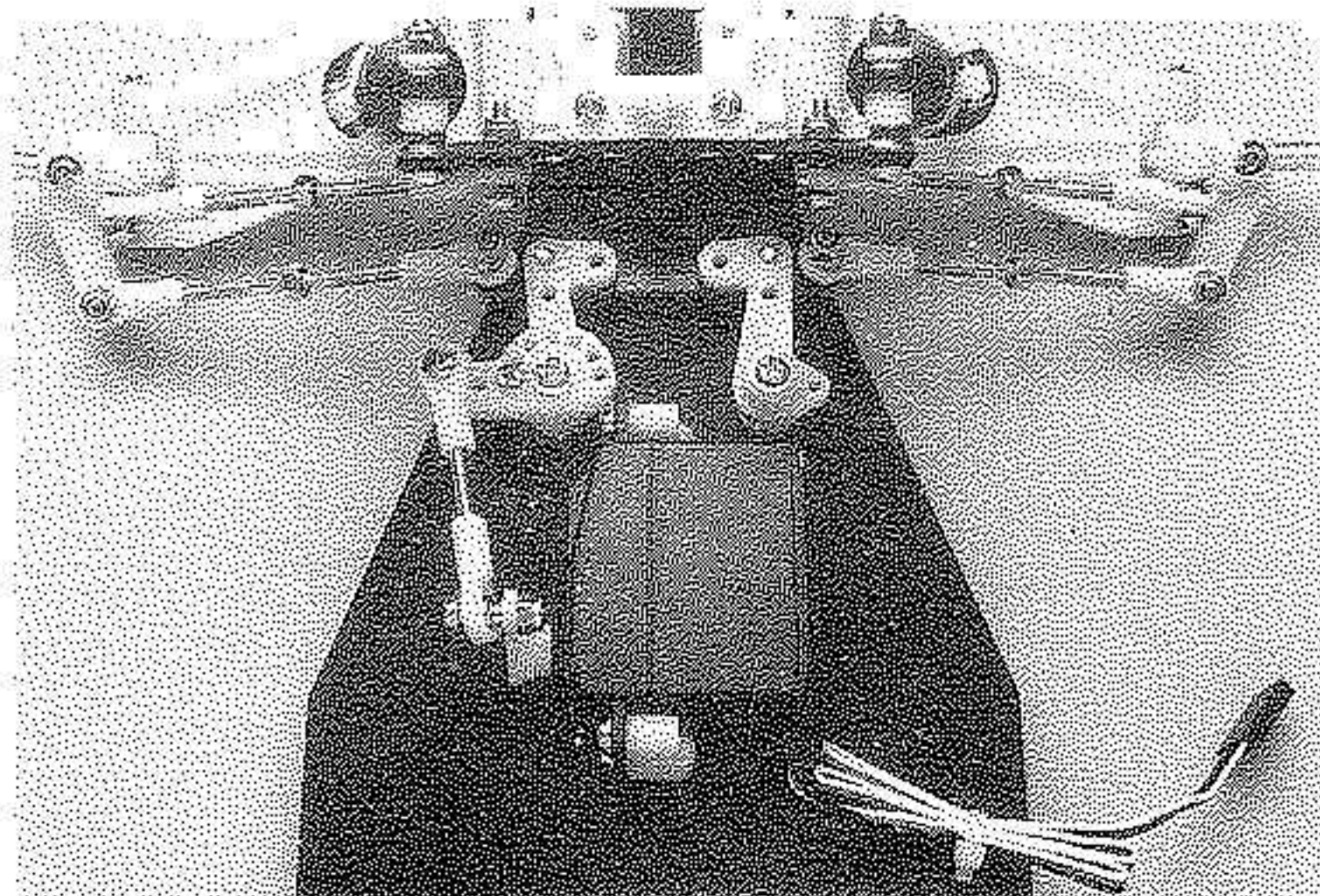

### STEP F-16

Position the servo on the chassis as shown and line up the holes in the servo mounts with the countersunk holes in the chassis. Insert two 3x8mm countersunk self-tapping screws through the bottom of the chassis and into the two servo mounts.

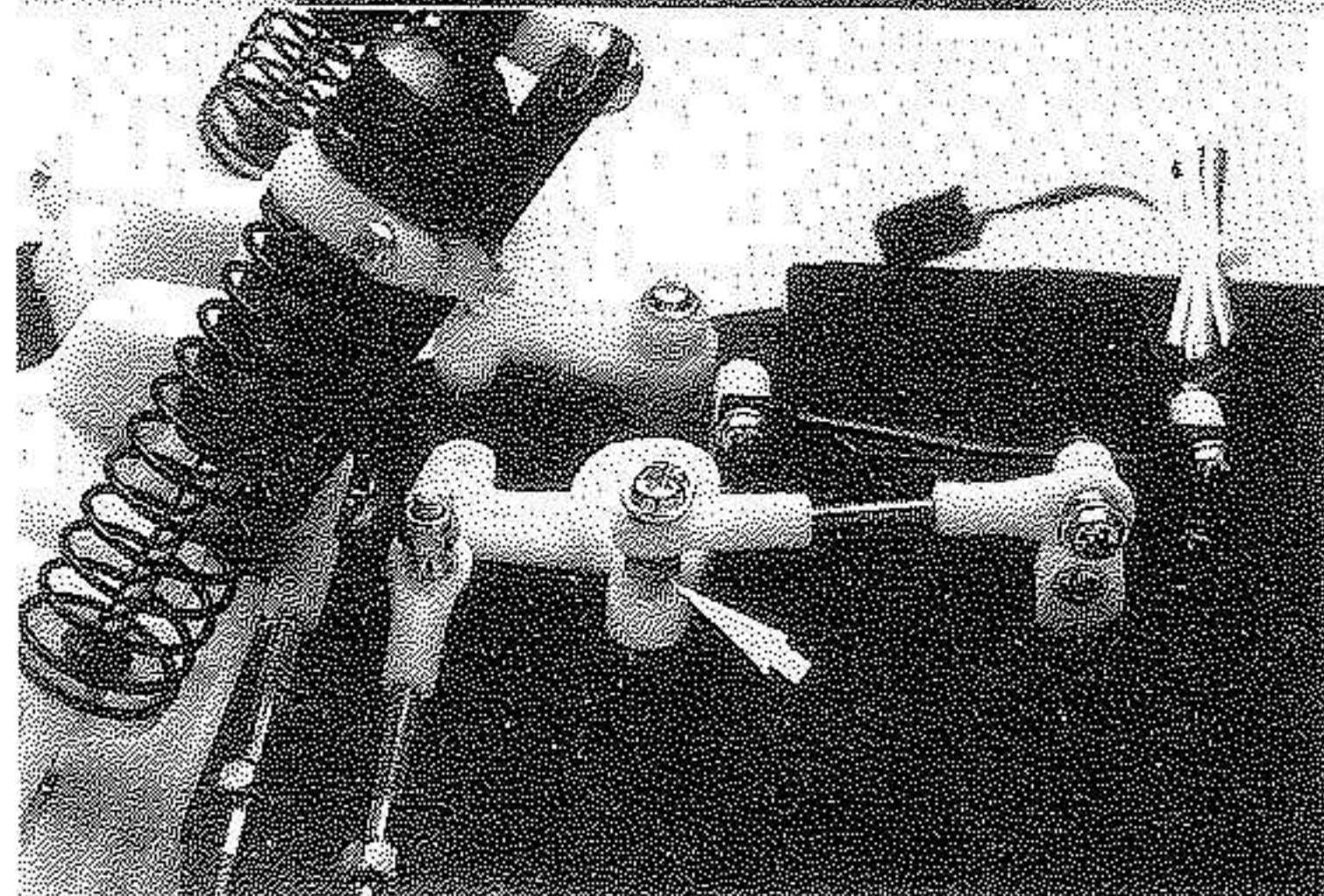

### STEP F-17

Attach the other end of the steering rod to the outermost hole of the radius arm. Use a 3X15mm washerhead machine screw and a 3mm flat nut to secure the rod. Put the nut between the hollow ball connector and the radius arm (arrow).

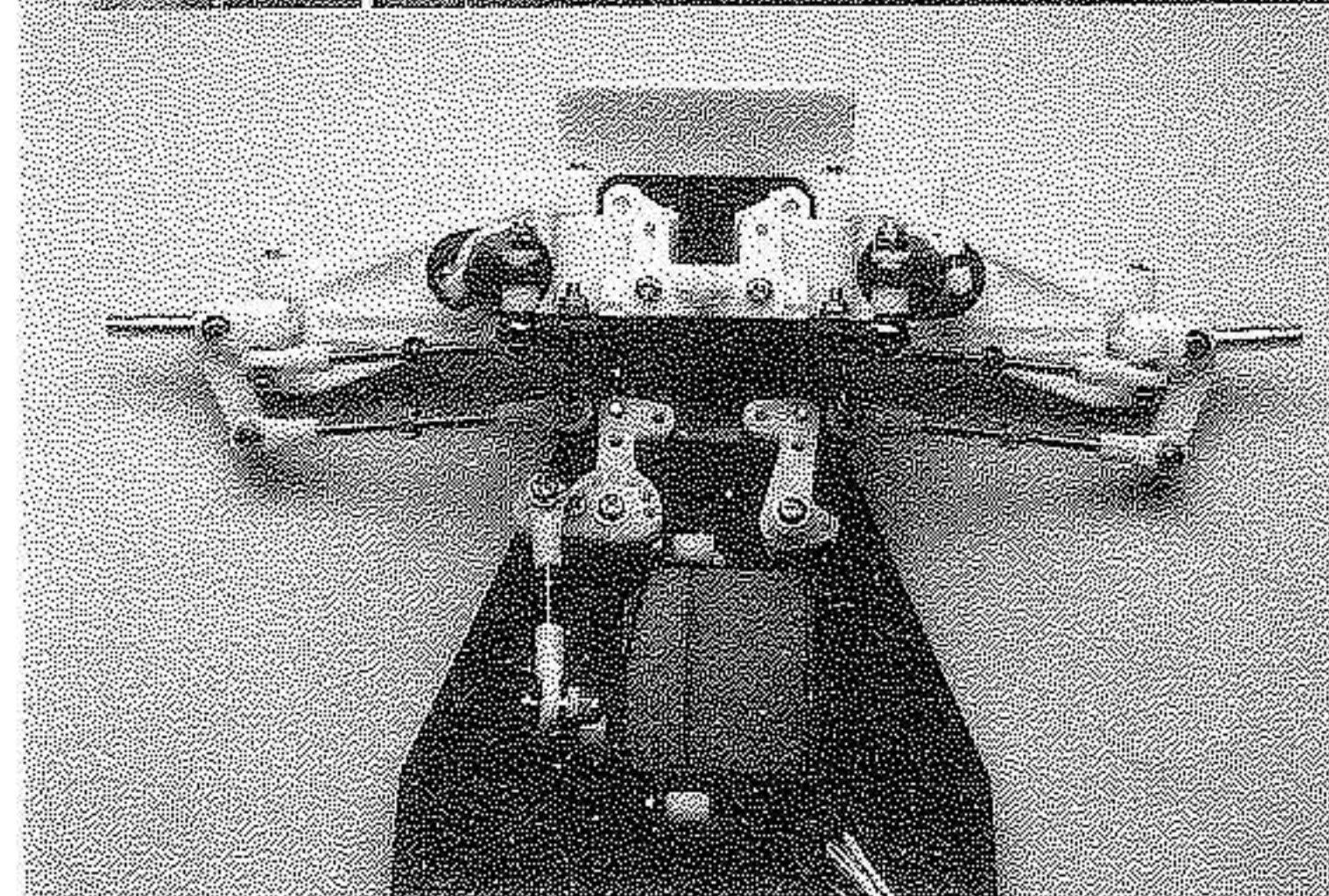

### STEP F-18

Your completed front end and steering assembly should look like this.

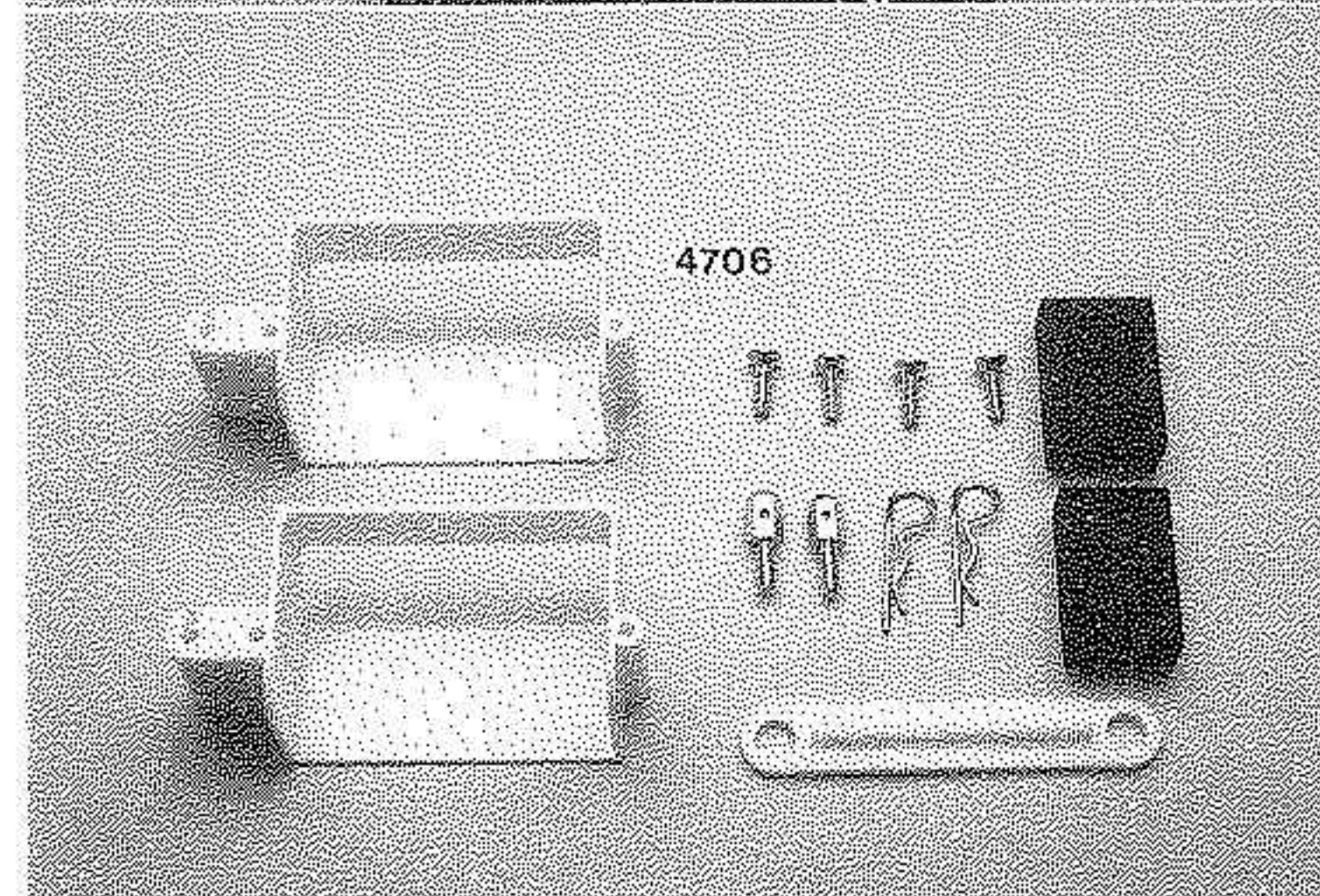

## BAG G

### STEP G-1

Locate the two battery cups (4706), two adhesive foam pads (4706), four 3X10mm self-tapping countersunk screws, the two hold-down posts (4706), the battery hold-down plate (4706), and two body clips.

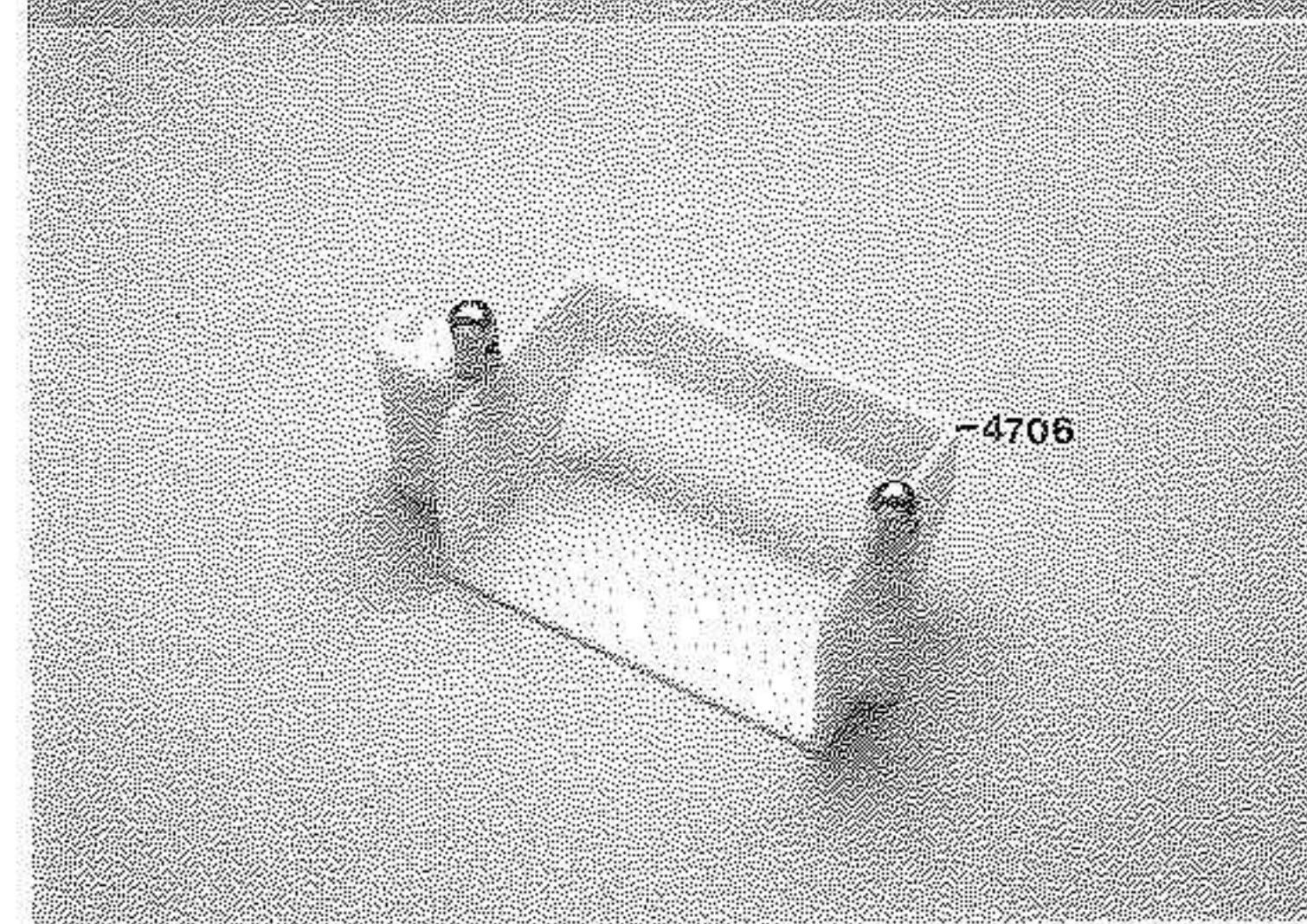

### STEP G-2

Screw the two hold-down posts (4706) into the holes on top of the battery cup.

3X15mm WASHERHEAD  
MACHINE SCREW

3mm FLATNUT

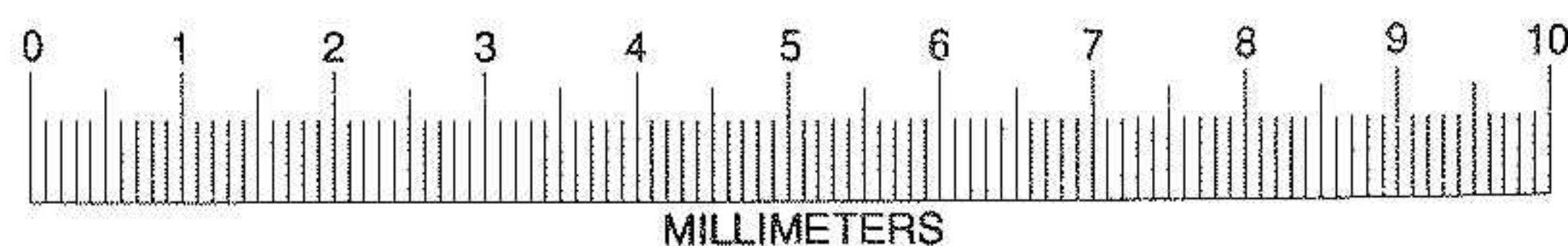

MILLIMETERS

3 x 10mm. COUNTERSUNK  
SELF-TAPPING SCREW

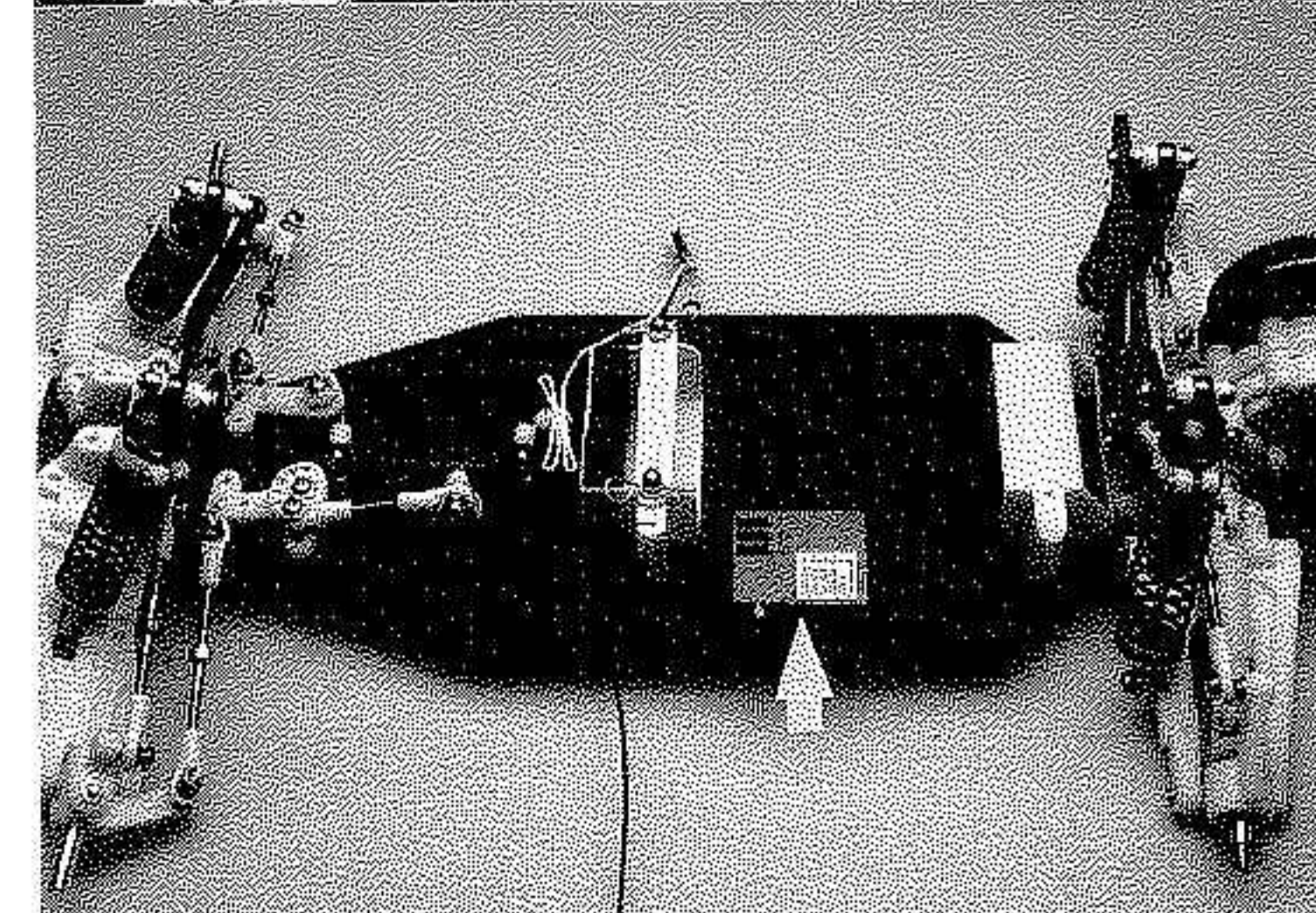
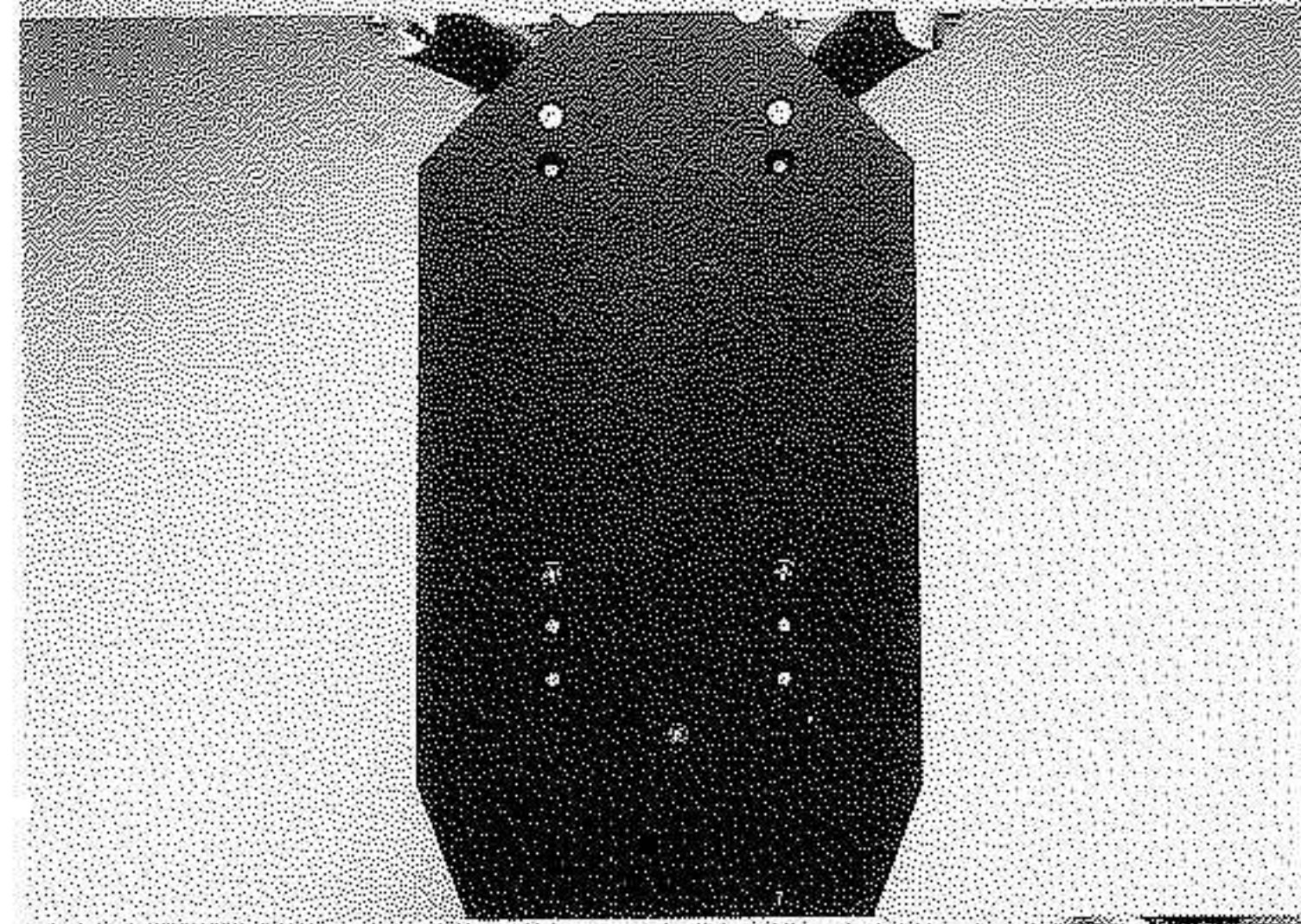
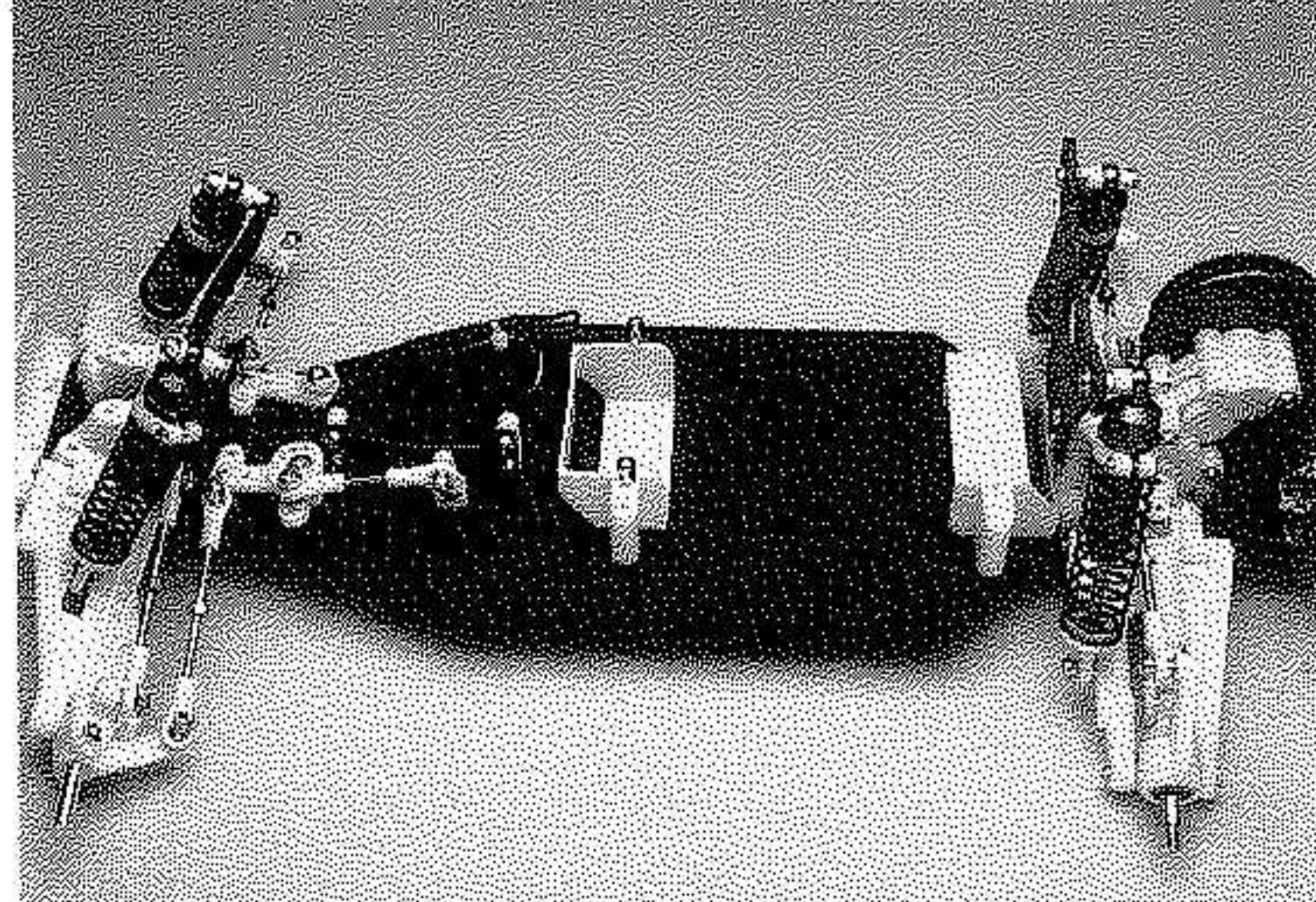
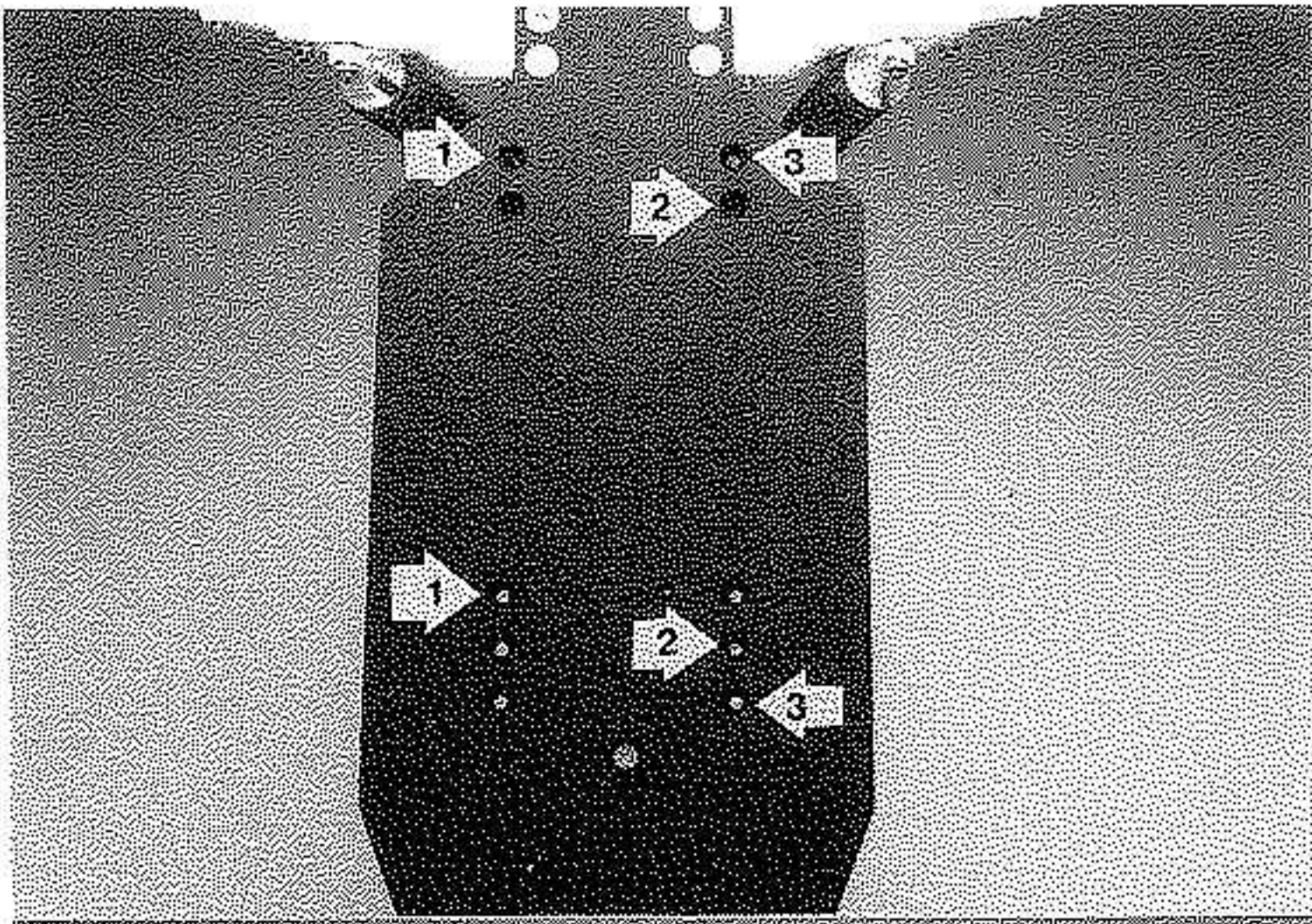

### STEP G-3

Note on the chassis that there are several sets of mounting holes available for the battery cups. The pair of holes labeled by the #1 arrows are for mounting the standard 6-cell stick battery or 7-cell hump pack. This would be the most commonly used location. The holes marked with the #2 arrows are also for 6-cell stick packs and 7-cell hump packs, but the batteries are moved forward by 11.5mm. This changes the front to rear weight distribution by approximately 2 percent. The holes marked by the #3 arrows are for mounting 7-cell flat stick packs. Mounting the battery cups in this position will require remounting the steering servo in a different location.

### STEP G-4

Decide which mounting holes you want to use and position the battery cups on the chassis. Note that the battery cup at the rear of the truck is turned upside down. This is to provide a flat mounting place for your electronic speed control (not included).

### STEP G-5

Turn the chassis over and use two 3X10mm self-tapping countersunk screws to fasten each battery cup.

### STEP G-6

Remove the adhesive backing from the foam pads (4706) and stick them onto the front battery cup. If the cells in your battery packs are arranged in a side-by-side manner, you won't need the foam pads. Locate the battery hold-down plate (4706) and two body clips. Secure the plate to the battery cup with the two body clips.

### STEP G-7

There are several different options for mounting your receiver. For this assembly manual, we have chosen to mount the receiver on the left side of the chassis, between the servo and the speed control. The antenna wire can then be routed directly to the antenna mount on either the front or rear battery cup. Use high quality servo tape to mount your receiver to the chassis. Be sure to clean both the surface of the chassis and the radio with rubbing or denatured alcohol, to remove any grease or oil.

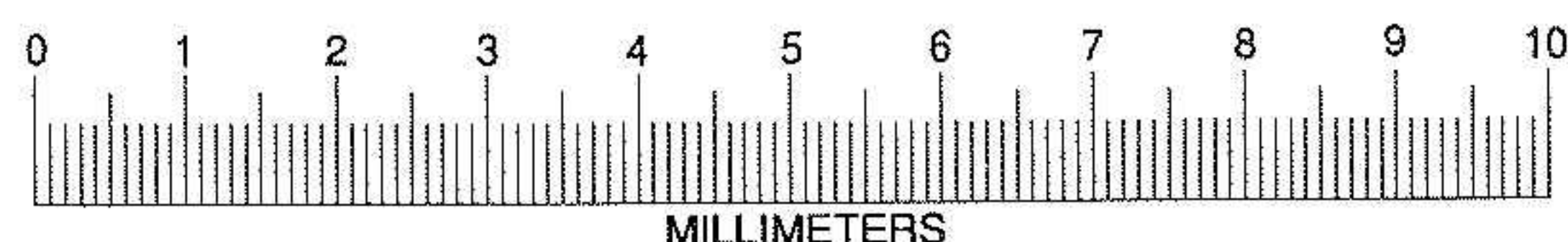

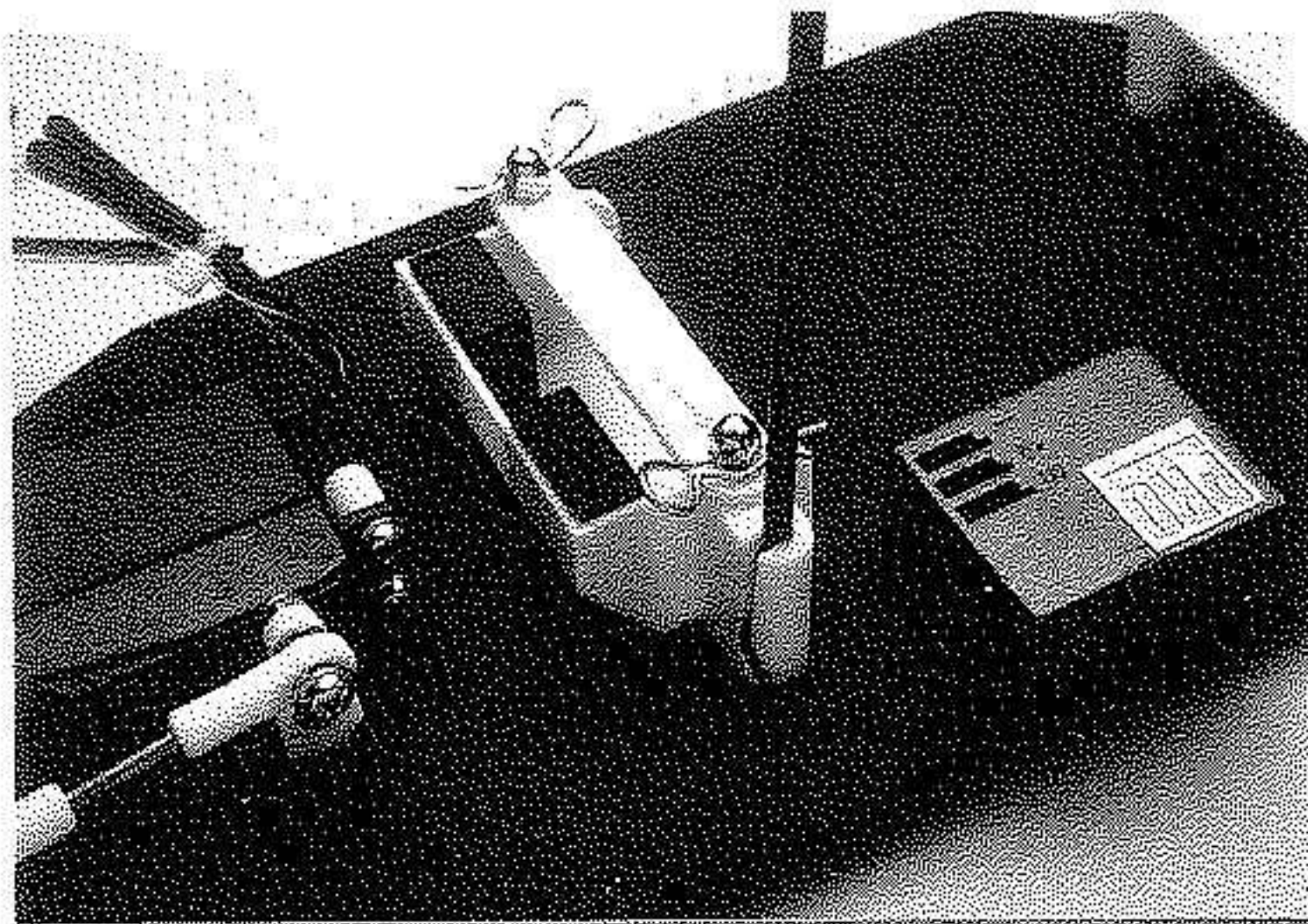

### STEP G-8

Locate the plastic antenna tube (1726). Measure how much antenna length will be required to go into the tube (approximately 12 1/2 inches). Wind the extra remaining antenna wire around the plastic spool (1926) (shown below). Next, push the 12 1/2 inches of antenna wire through the antenna tube. Now, push the antenna tube into the slot in the side of the battery cup.

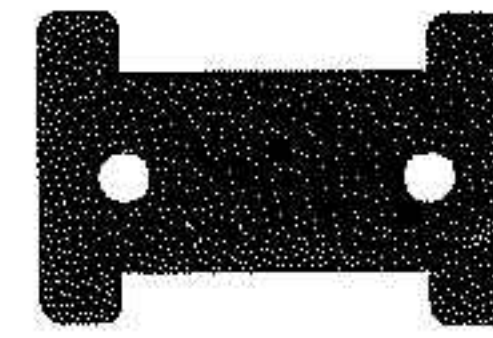

### STEP G-9

Fold the excess antenna wire over the end of the tube and secure it with the antenna tip (1926).

**RACER'S TIP:** Do not cut the antenna wire on your receiver. The antenna length is specifically tuned to your receiver's frequency. Cutting it will shorten your range and could create other radio problems.

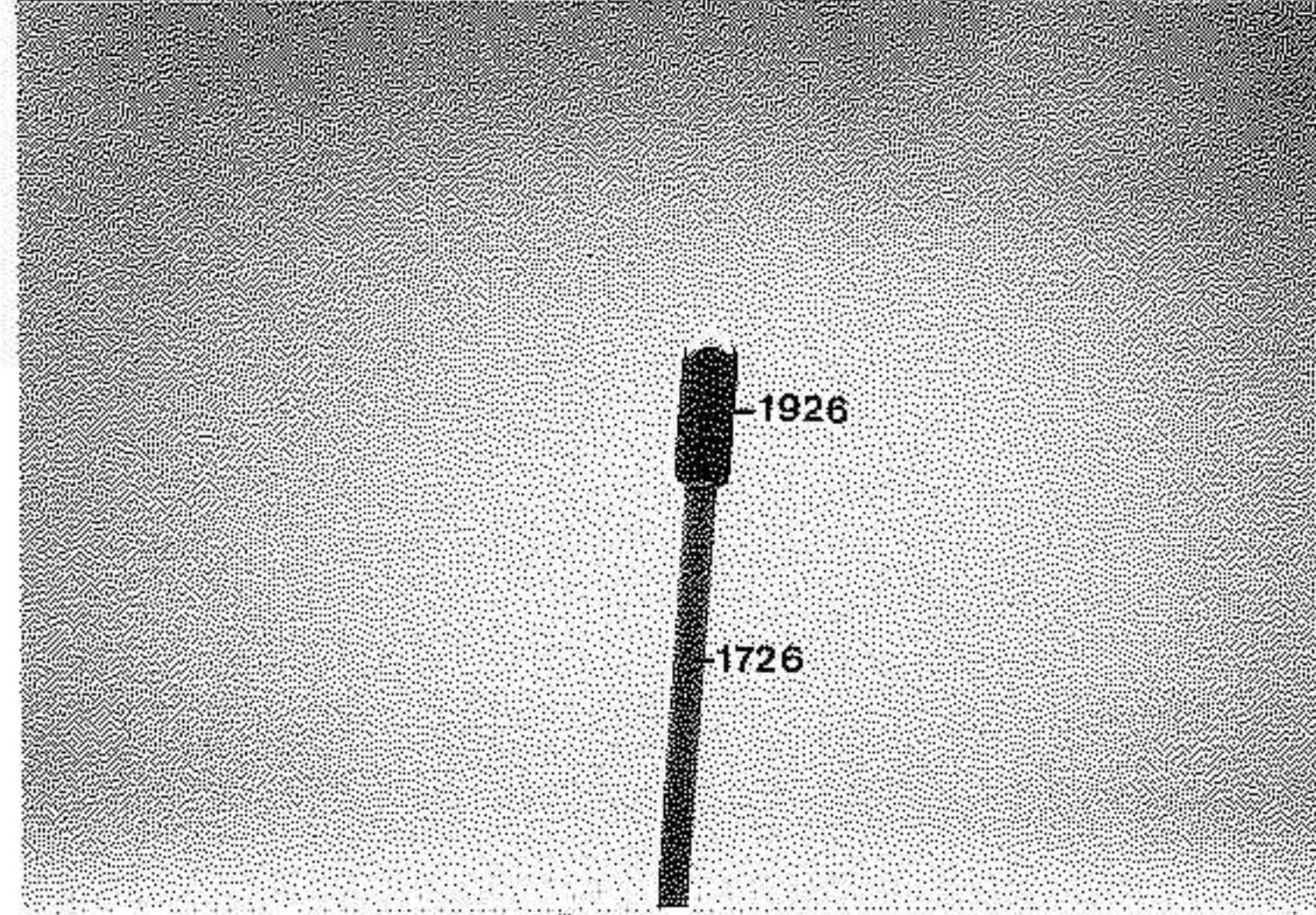

### STEP G-10

Mount your electronic speed control to the top of the rear battery cup with servo tape. Be sure there is no grease or oil on the bonding surfaces.

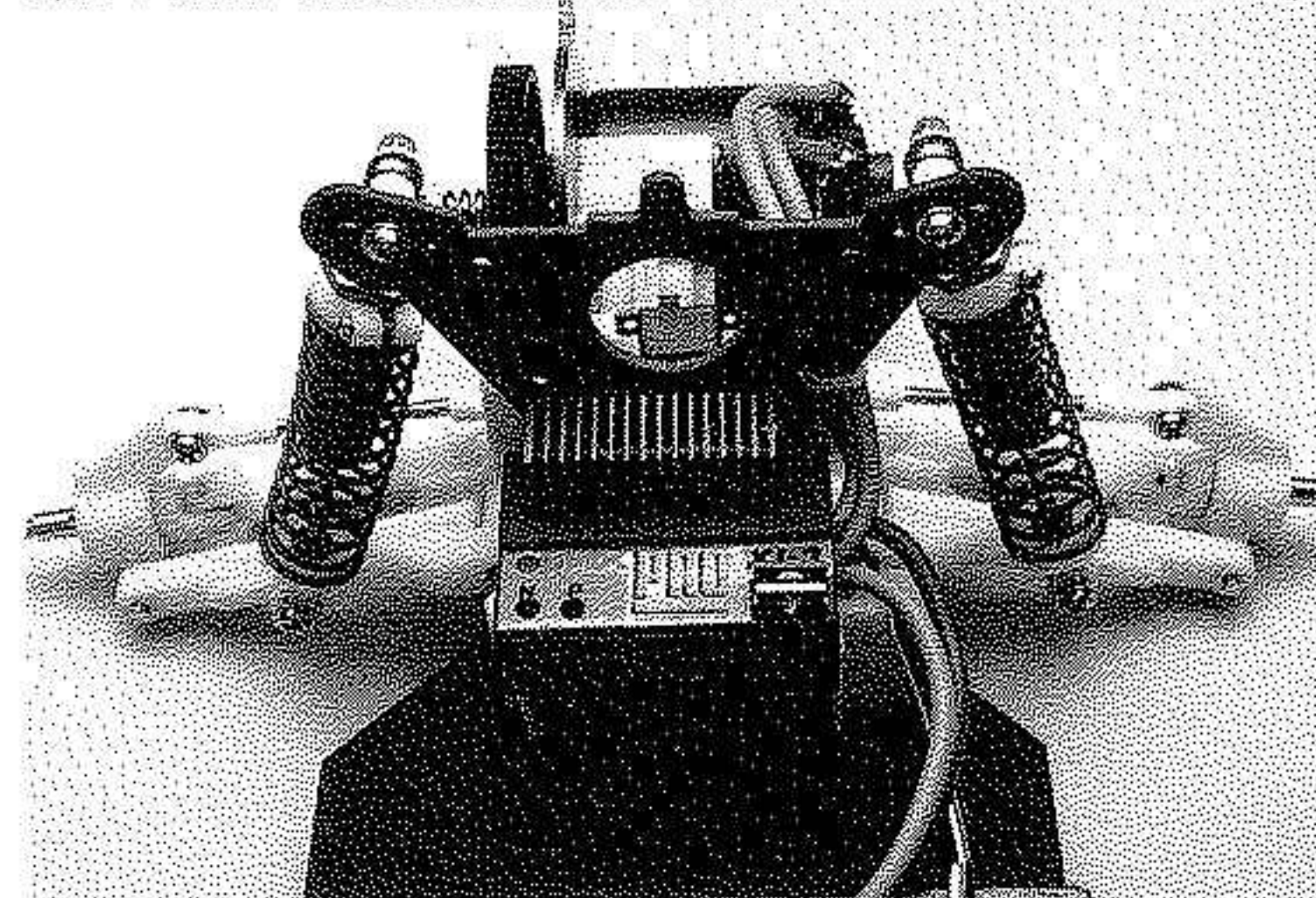

### STEP G-11

Route the servo cable and on/off switch wires so that they will not interfere with the battery removal/installation. Use electrical tape to mount the wires flat against the chassis. Route the motor wires between the shock and shock tower and secure them to the shock tower with a cable tie (2734). You may want to mount the on/off switch on the rear bulkhead with servo tape as shown.

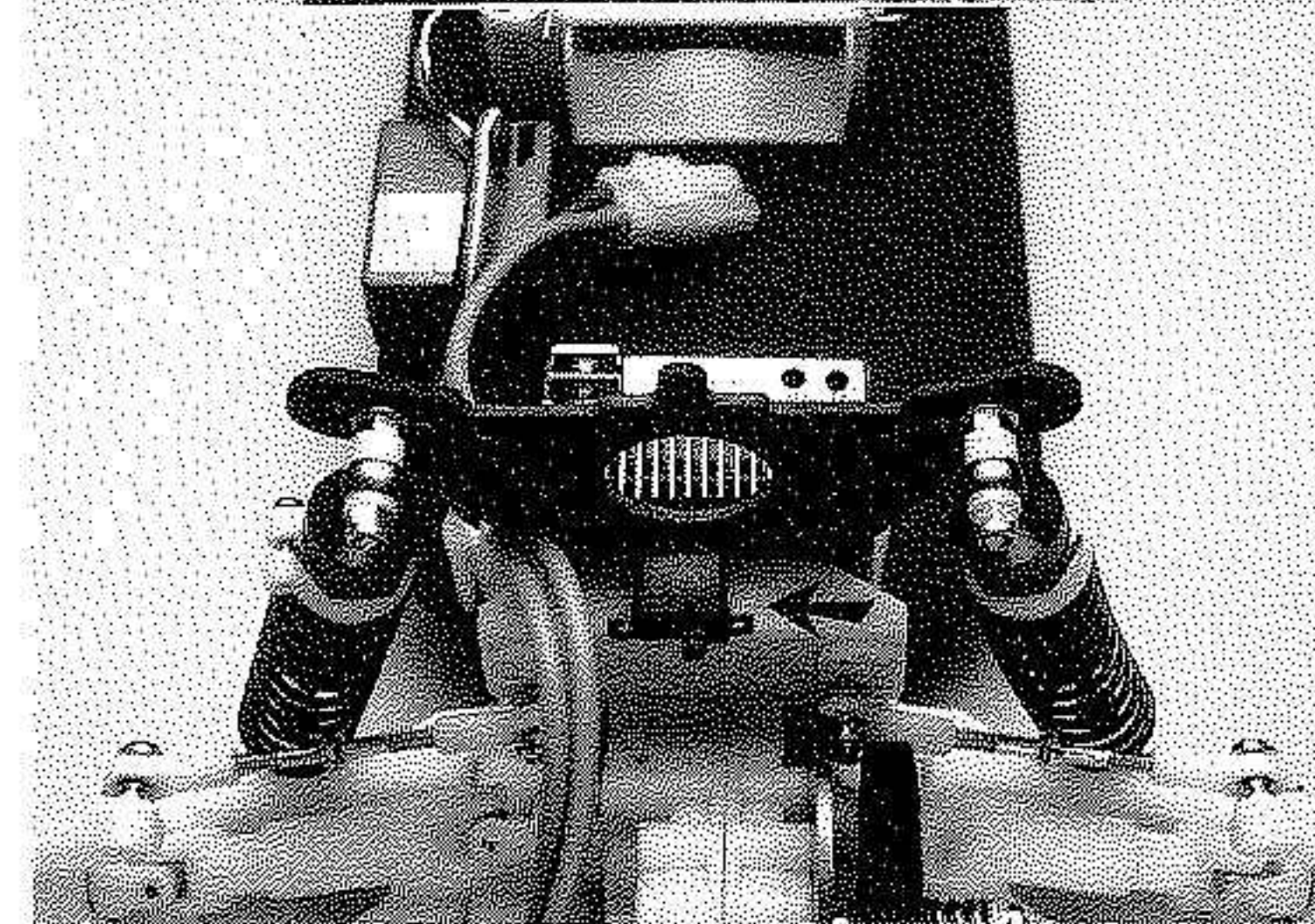

## BAG H: WHEELS AND TIRES

### STEP H-1

Locate the bag containing the wheels (front 2771; rear 2770) and tires (front 4740; rear 4750). Stretch the tires over the rims until the bead is seated completely, on both sides. Glue the tires to the rim by rolling the bead back with your thumb and inserting a drop of Superglue in 3 or 4 places around the tire.

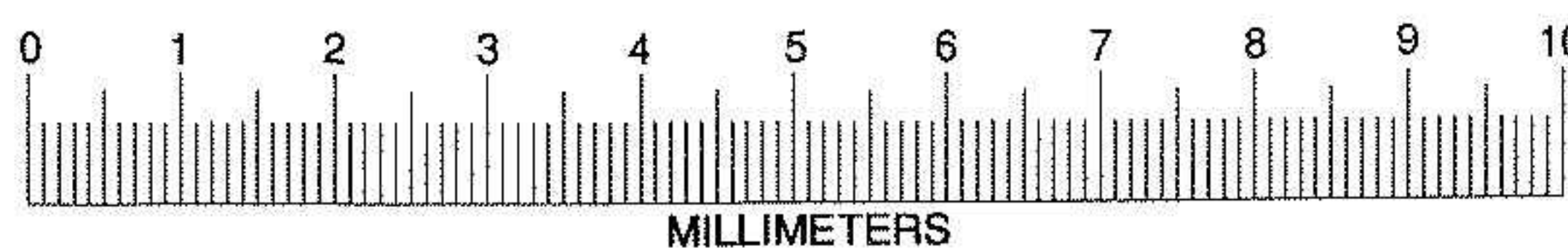



### STEP H-2

Press two 5X11mm bearings (4610) into the center of each front rim (2771) (arrow).

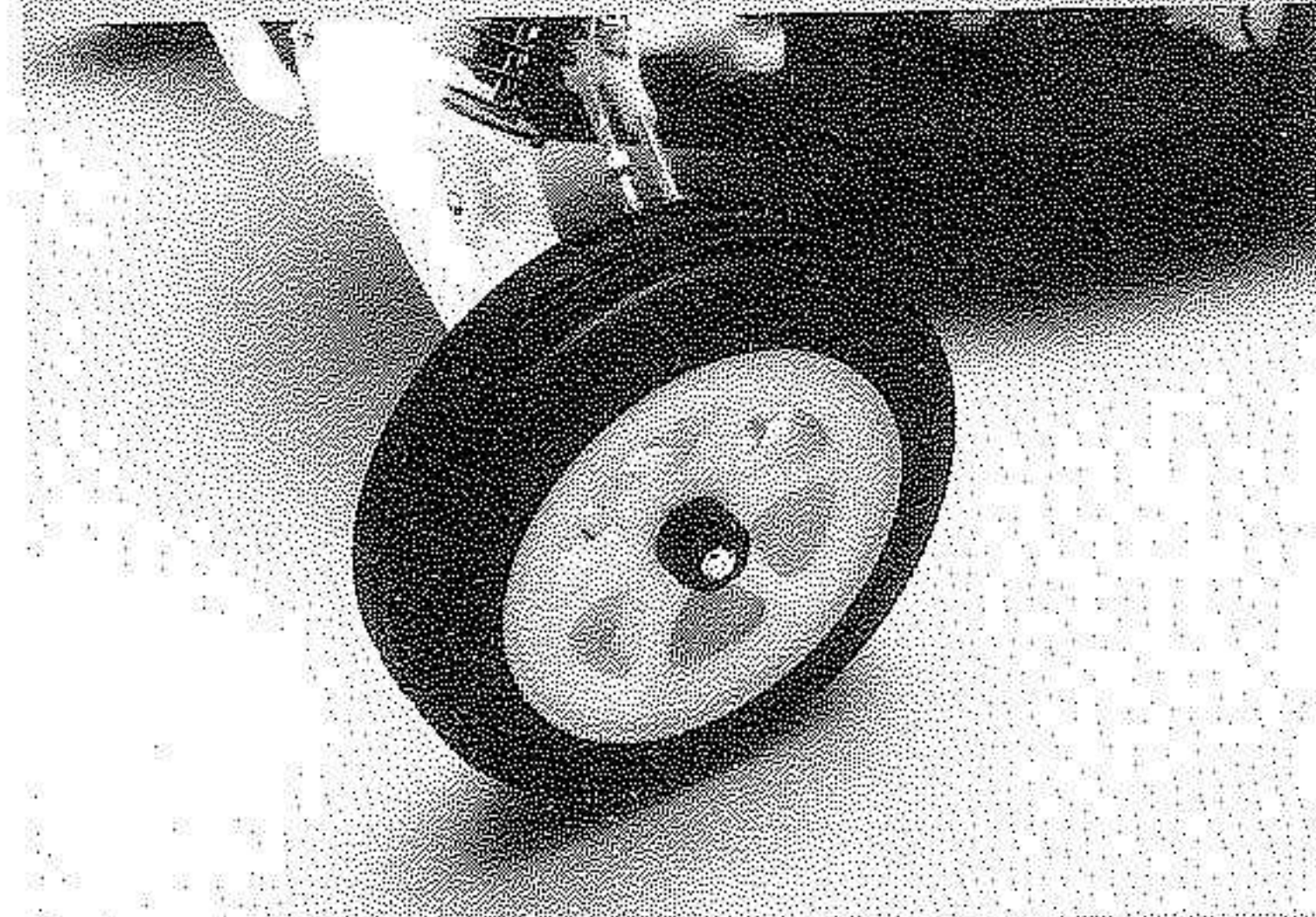

### STEP H-3

Slide the front wheels over the spindles and then secure them with 5mm nylon locknuts (2747).

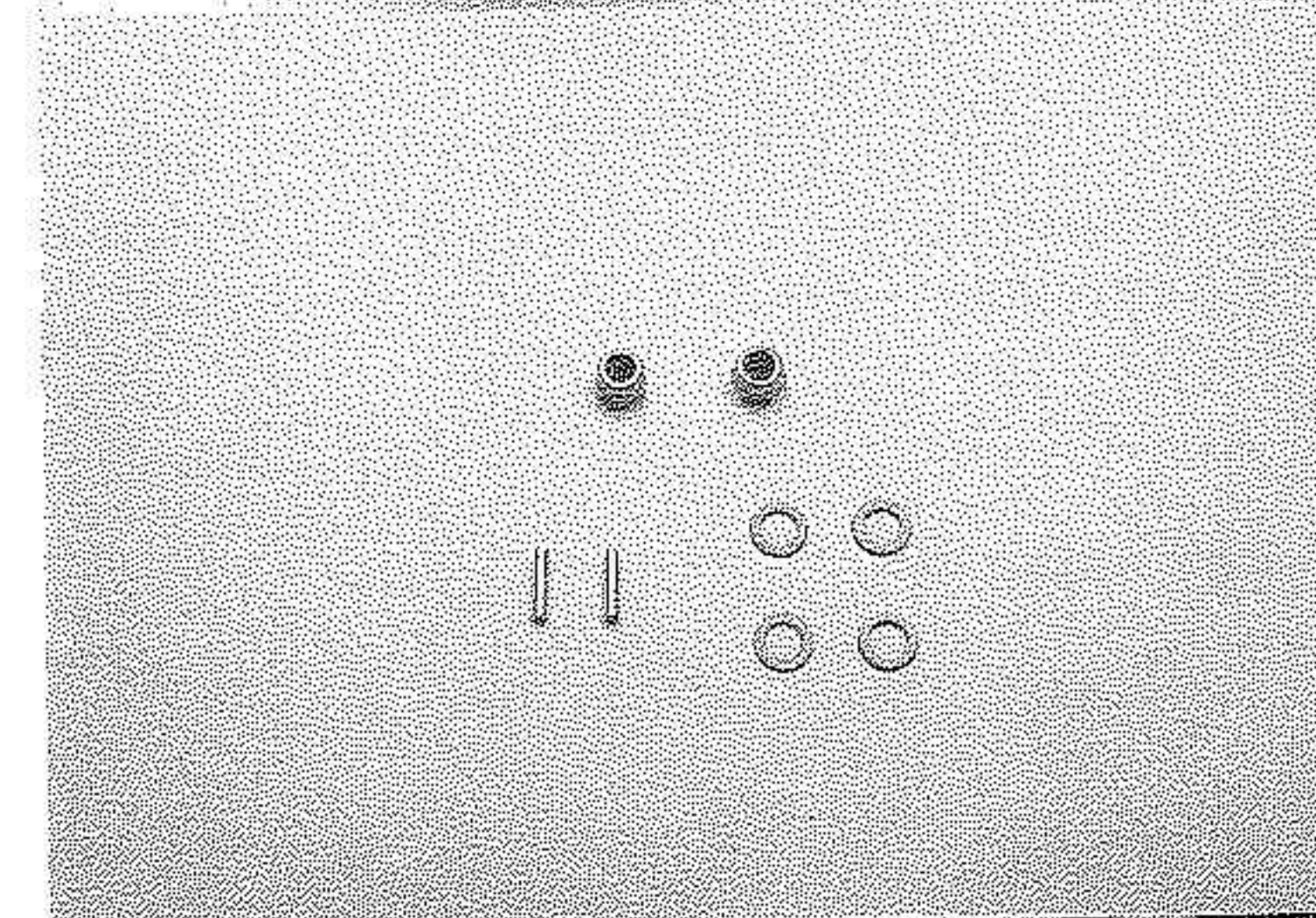

### STEP H-4

Locate the two stub axle pins (1654), four 5X8mm fiber washers, and two 4mm locknuts.

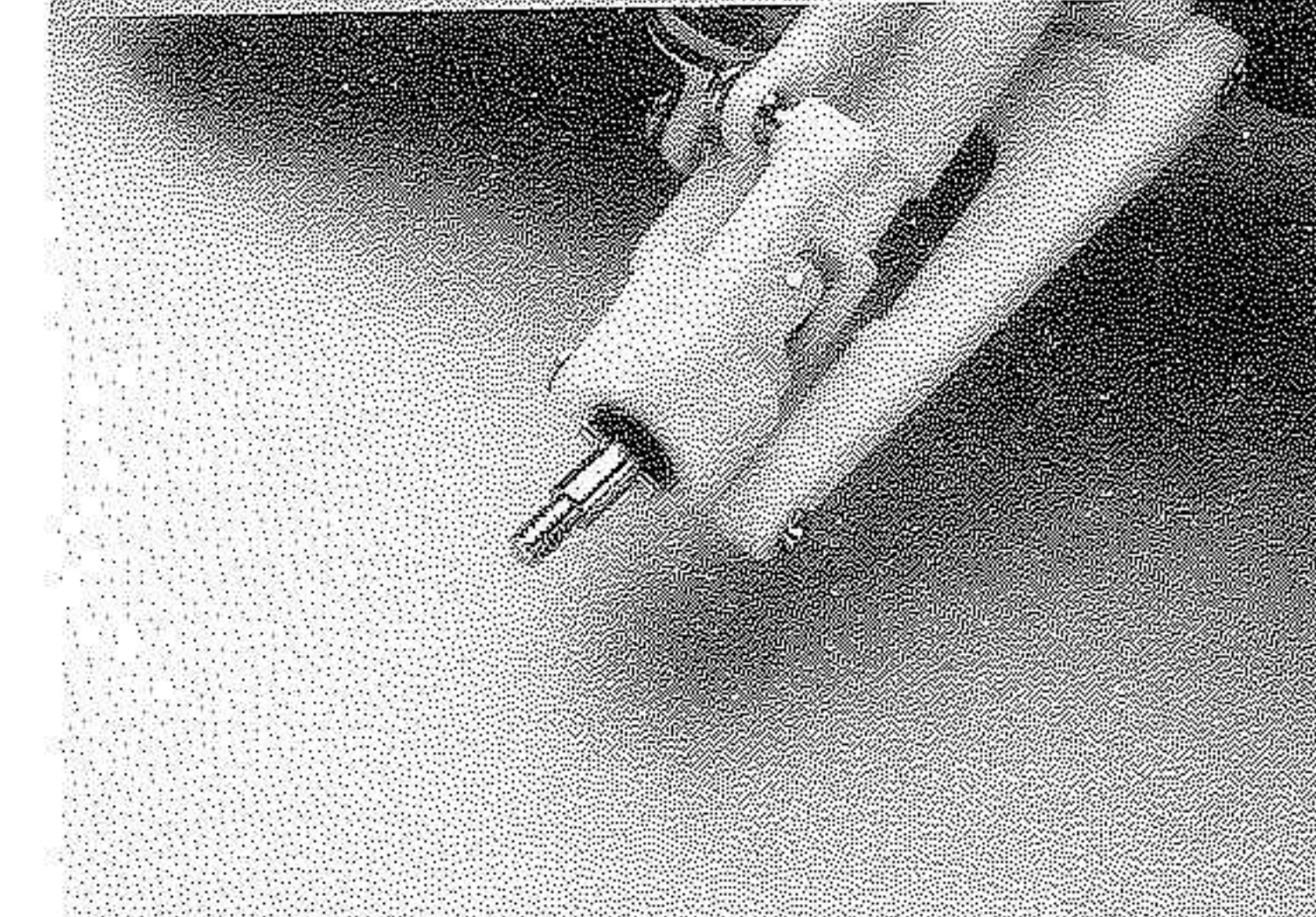

### STEP H-5

Slide a 5X8mm fiber washer over each rear axle. Now, insert the stub axle pin into the hole in each stub axle.



### STEP H-6

Slide the rear wheel on the stub axle, followed by another 5x8mm fiber washer. Then secure the wheel with a 4mm metal locknut. Repeat for the other rear wheel.

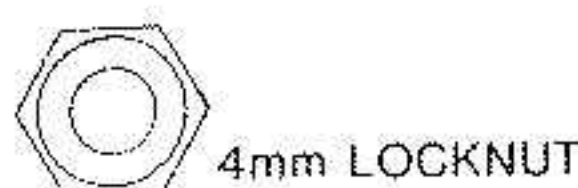

4mm LOCKNUT

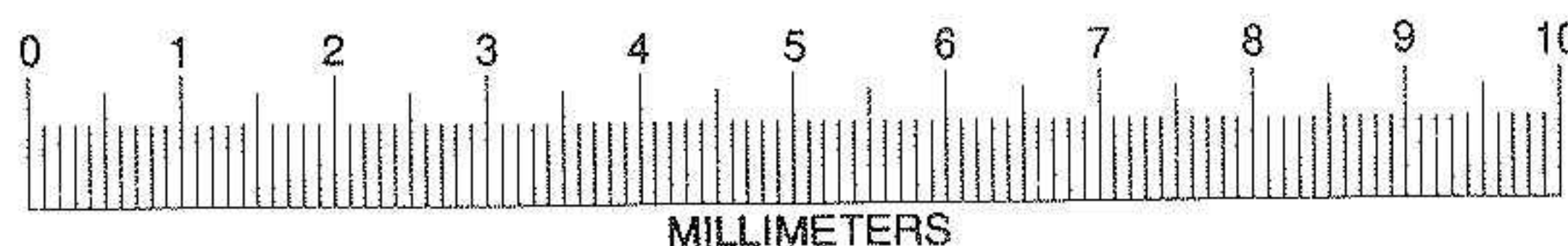

MILLIMETERS



5X8mm FIBERWASHER

## BAG I BODY AND WING

### STEP I-1

Locate the clear Lexan wing (2712), the wing wire (2714), two wing buttons (2714), two wing mounts (1715), four 3mm grub screws, and two 3x8mm washerhead machine screws.

### STEP I-2

Trim the Lexan wing so that it resembles the photo. The wing has two marks on it indicating where the holes should be punched in order to insert the wing buttons. A sharp reamer, or a Dremel tool with a cone shaped grinder, will make the cleanest hole. The hole should be 7mm in diameter.

### STEP I-3

Fasten the wing mounts (1715) to the rear shock tower, as shown, with the 3x8mm washerhead machine screws.

### STEP I-4

If you wish to paint your wing, you should do so before performing the next 3 steps. Often, racers do not paint their wings because they have to be replaced fairly frequently. Assuming the wing is painted, place a strip of masking tape over each hole, as shown in the photo. Use an X-acto knife to open up the wing button holes. The tape is to prevent the paint from being scratched when the wing wire is installed. Now push the wing buttons through the holes in the wing.

### STEP I-5

Carefully insert the wing wire through the wing buttons. When the wing is lined up straight on the wire, insert a 3mm grub screw into the bottom of each of the wing buttons. Tighten the grub screws against the wing wire.

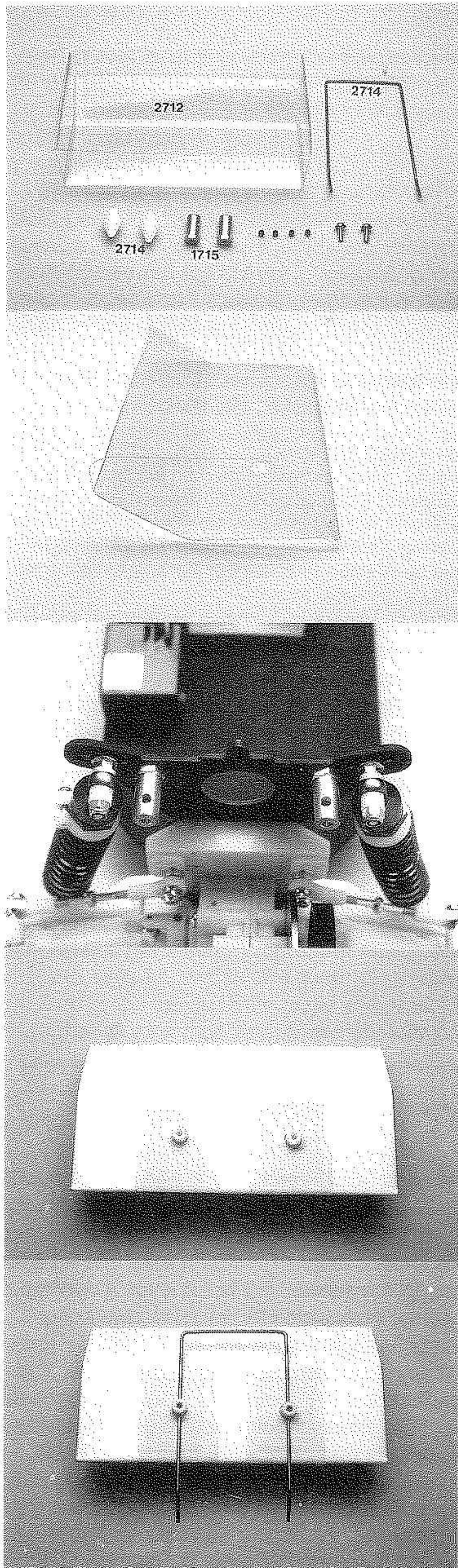

 3mm SET (GRUB) SCREW

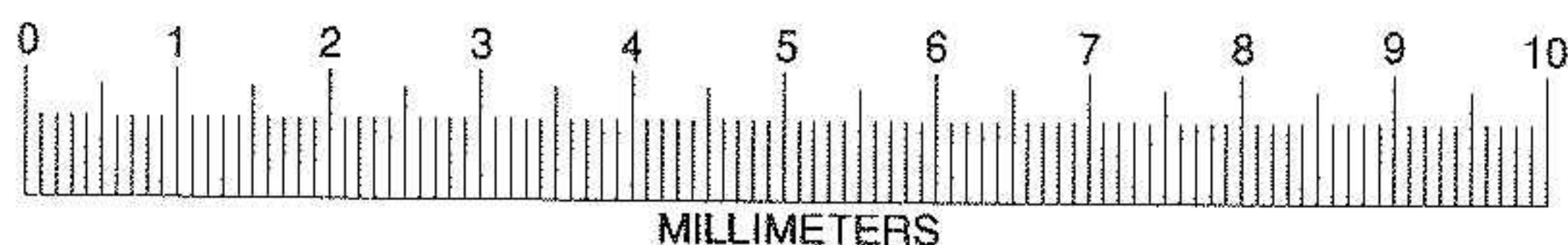

MILLIMETERS

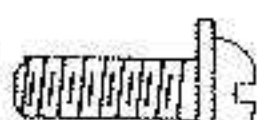
 3X8mm WASHERHEAD MACHINE SCREW

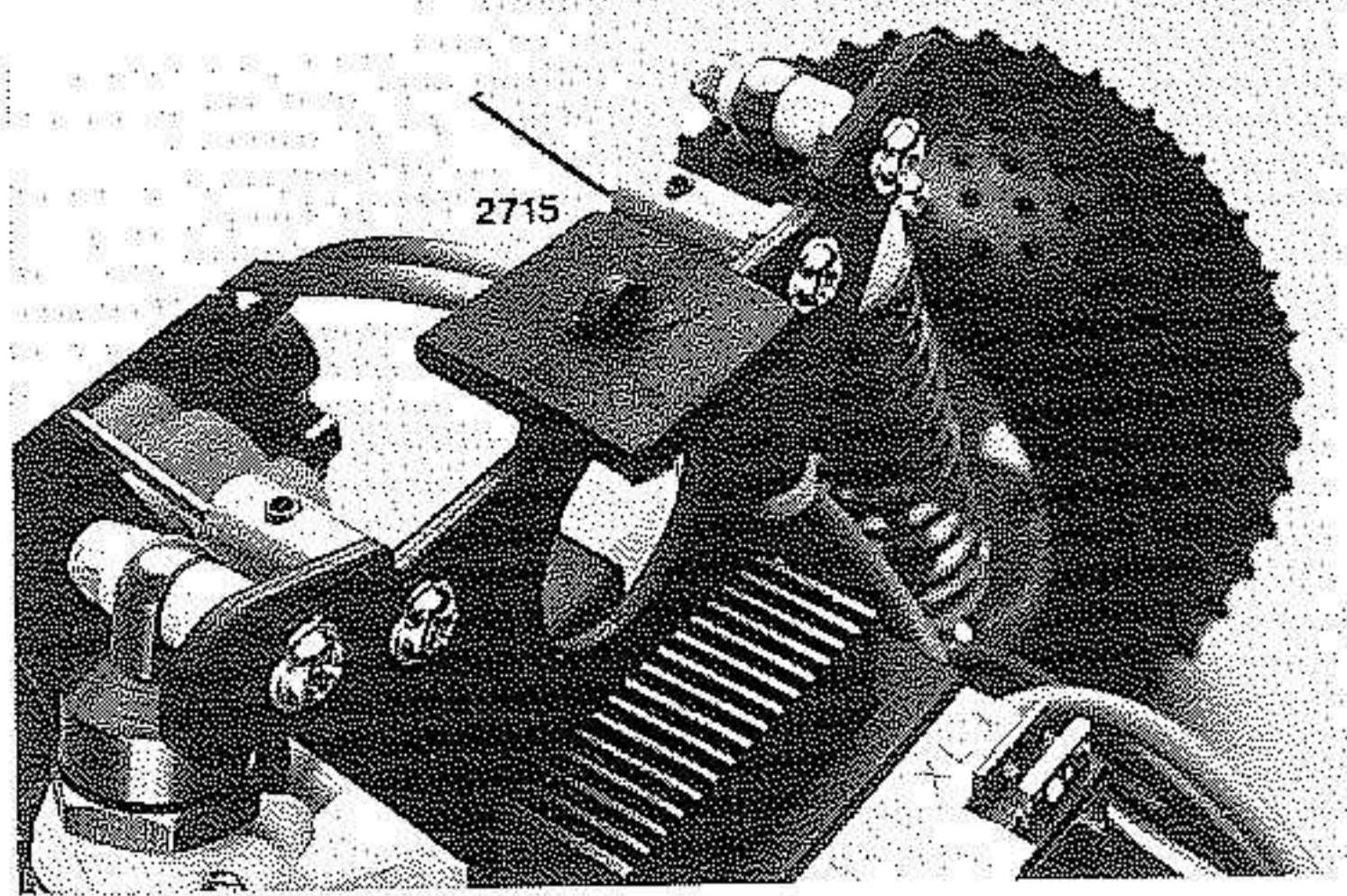
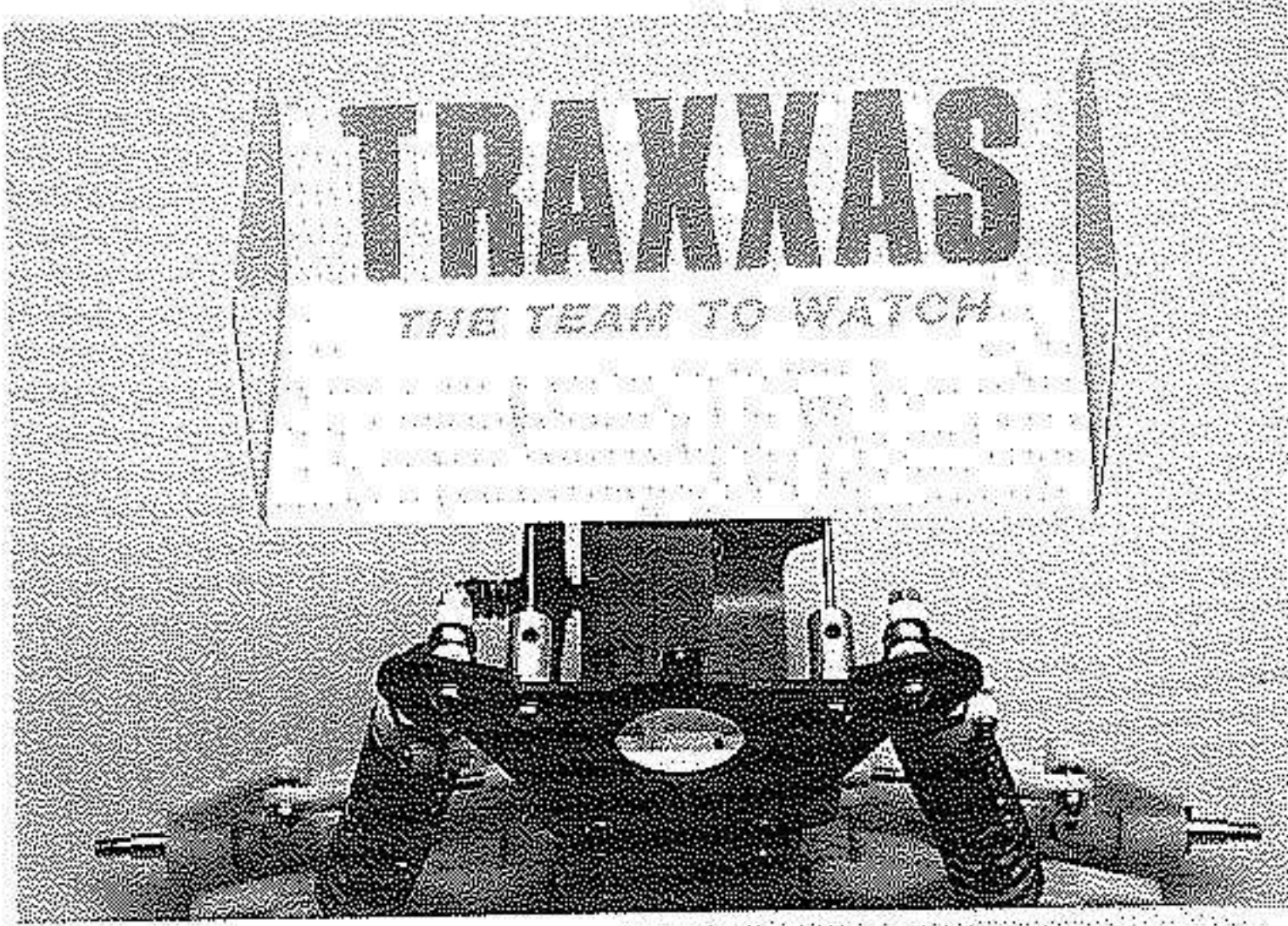

### STEP I-6

Insert the ends of the wing wire into the wing mounts. Insert a 3mm grub screw into the top of each wing mount, and tighten it against the wing wire.

### STEP I-7

Locate the 20x20mm slotted rubber square (2715). Place this square over the body mount in the center of the rear shock tower.

Your car is now assembled! All that is left to do is detail the body and make final adjustments. Read the next section on painting bodies for valuable hints on applying a quality paint job. Detailed drawings are provided to help you properly cut the body out. Before hitting the track, read through the tuning guide so that you will have a full understanding of how your car can be affected by changing the various adjustments.

