

TEAM ASSOCIATED



RC10GT

1/10 SCALE GAS OFF ROAD TRUCK



COMPLETE CATALOG

RC10GT

1:10 SCALE GAS OFF ROAD TRUCK CATALOG

1:10 RC10GT GAS TRUCK CATALOG ORDER FORM

mail order to: Associated Electrics, Inc.
3585 Cadillac Ave.
Costa Mesa, CA 92626 USA
Phone orders: (714) 850-9342 FAX orders: 714-850-1744
Please have your order ready before calling.

NAME _____

ADDRESS _____

SHIPPING \$ _____

CA SALES TAX \$ _____

TOTAL AMOUNT OF ORDER IN U.S. FUNDS: \$ _____

ORDERING INSTRUCTIONS

DO NOT SEND CASH. NO CREDIT CARD ORDERS ACCEPTED.
California residents add sales tax: 7.75% in Orange County, 6.25% elsewhere.

Add shipping fee of \$4.00 to all orders except Blue and Red Label. C.O.D. fee is \$4.50 (C.O.D. = "Cash On Delivery": paying purchase price directly to shipper upon delivery instead of prepaying us.)

All international orders must be prepaid by International Money Order in U.S. funds.

Extra charge for faster Blue and Red Label service is available. **SHIPPING CHARGES SUBJECT TO CHANGE WITHOUT NOTICE.**

CATALOG #10GT JULY 1994

This free catalog is updated yearly; is yours current?
Prices subject to change without notice.

If you cannot obtain parts from your distributor or dealer, you may order them directly from us. (We're sorry, you cannot order truck kits from us.)

qty part no description price

BUSHING KITS

FOR PULL START OR NON PULL START ENGINES

#7050 BASIC SPORT TRUCK \$250.00

Basic bushing rolling chassis kit and body, gold anodized shocks, and dogbone driveshafts. Requires the addition of your favorite .12ci/.15ci gas engine (with or without pull start) and radio system. *(NOTE: also requires one of the Associated Engine Installation Packs to complete assembly. See page 3.)*

FOR PULL START ENGINES

#7055 COMPLETE SPORT TRUCK (less engine) \$320.00

Complete bushing kit with gold anodized shocks and dogbone driveshafts. Requires the addition of your favorite .12ci/.15ci gas engine and radio system to complete. *(NOTE: Associated Engine Installation Pack included in kit. See page 3.)*

PLEASE SPECIFY TYPE OF ENGINE

BALL BEARING KITS

FOR PULL START OR NON PULL START ENGINES

#7060 BASIC TEAM TRUCK \$362.00

Basic ball bearing kit with rolling chassis and body, hard anodized shocks, and rear universal driveshafts. Requires the addition of your favorite .12ci/.15ci gas engine (with or without pull start) and radio system to complete. **(NOTE: also requires one of the Associated Engine Installation Packs to complete assembly. See below.)**

FOR PULL START ENGINES

#7065 COMPLETE TEAM TRUCK (less engine) \$445.00

For pull start engines. Complete ball bearing kit with hard anodized shocks and rear universal driveshafts. Requires the addition of your favorite .12ci/.15ci pull start gas engine and radio system to complete. **(NOTE: Associated Engine Installation Pack included in kit. See below.)**
PLEASE SPECIFY TYPE OF ENGINE

FOR NON PULL START ENGINES

#7066 COMPLETE TEAM TRUCK (less engine) \$445.00

For non pull start engines. Complete ball bearing kit with hard anodized shocks and rear universal driveshafts. Requires the addition of your favorite non pull start .12ci/.15ci gas engine and radio system to complete. **(NOTE: Associated Engine Installation Pack included in kit. See below.)**
PLEASE SPECIFY TYPE OF ENGINE

ENGINE INSTALLATION PACKS

Engine packages are currently set up for .12 size gas engines such as the Dynamite TNT, Yokomo RX, and O.S. Max CZR or CZZ, pull start and non pull start models. *More coming.*

BE SURE TO SPECIFY YOUR TYPE OF ENGINE ON THE ORDER FORM AT RIGHT.

Engine Installation Packs include:

- engine mount adapters
- flywheel
- clutch assembly (clutch bell, clutch bearings or bushings, clutch shoes, clutch spring, and clutch nut with clip)
- exhaust manifold and tuned pipe muffler
- silicone exhaust tubing and fuel line tubing
- air filter
- boot and foam prefilter
- engine mount adapters
- VHS video, "How to Tune Your RC10GT Engine".

For O.S. Max CZR, Dynamite TNT and Yokomo .12 size engines.

qty	part no	description	pkg	price
	#7680	Engine Installation Package with bushing clutch for pull start engine. For RC10GT kit #7050.	1	\$75.00
	#7681	Engine Installation Package with ball bearing clutch for pull start engine. For RC10GT kit #7060.	1	\$90.00
	#7683	Engine Installation Package with ball bearing clutch for non pull start engine. For RC10GT kit #7060.	1	\$90.00

PLEASE SPECIFY TYPE OF ENGINE:

qty	part no.	description	pkg	list price	qty	part no.	description	pkg	list price
-----	----------	-------------	-----	------------	-----	----------	-------------	-----	------------

CLEAR TRUCK BODIES & ACCESSORIES

	6131	RC10GT GAS TRUCK BODY (will not fit electric RC10T's)	1	18.00
	6180	DRIVER, clear	1	2.00
	6191	HEADLIGHTS (2), and KNOCKOFFS (4)	1	2.50
	6192	HEADLIGHTS (2), and KNOCKOFFS (4) (#6191 but chrome-plated)	1	5.00
	7185	TRUCK REAR SPOILER	1	2.00

DECALS & STICKERS

3811



	3811	RC10GT DECALS, 2 sizes of "RC10GT", florescent red & yellow with "GT" in white smoke	1	2.00
	7195	TRUCK DECAL SHEET, for the #6122 body	1	4.00
	7196	RC10T TEAM TRUCK DECAL SHEET, for the #6130 body	1	4.00
	7197	RC10GT GAS TRUCK DECAL SHEET, for the #6131 Gas Truck body, 4 color mylar	1	4.00
	6195	DECAL SHEET, 4 color mylar, misc. sponsors	1	5.00
	6196	DECAL SHEET, Assoc. Car & Brands Logos, misc. sponsors, 4 colors	1	2.00

3817



	3817	ASSOCIATED BUMPER STICKERS, 1 large, 1 small. Red, white & blue.	1	4.00
--	------	--	---	------

3818



	3818	TEAM ASSOCIATED logo decal sheet, black	1	1.00
	3819	TEAM ASSOCIATED logo decal sheet, white	1	1.00

6855,
6856,
6857,
6858



Colored mylar Wheel Dots are adhesive-backed to cover the outside of wheels. Includes Associated and Reedy logos on each. Fits both buggy and truck wheels. Can be reused several times.

	6855	WHEEL DOTS, florescent pink	4 ea	2.00
	6856	WHEEL DOTS, florescent red	4 ea	2.00
	6857	WHEEL DOTS, florescent green	4 ea	2.00
	6858	WHEEL DOTS, florescent yellow	4 ea	2.00

FRONT SUSPENSION

	7200	TRUCK FRONT SUSPENSION KIT, no shocks (Bag 7-1)	1	30.00
	7206	TRUCK FRONT A-ARMS, NEW black composite material	pr	7.00

	7207	FRONT BULKHEAD, nylon	1	5.00
	7208	FRONT BULKHEAD ALUMINUM SUPPORT	1	1.50
	6210	FRONT BLOCK CARRIER, 30 deg. caster (kit standard)	pr	3.00
	6211	FRONT BLOCK CARRIER, 5 deg. caster	pr	4.50
	6212	FRONT BLOCK CARRIER, 10 deg. caster	pr	4.50
	6213	FRONT BLOCK CARRIER, 15 deg. caster	pr	3.00
	6214	FRONT BLOCK CARRIER, 20 deg. caster	pr	4.50
	6215	FRONT BLOCK CARRIER, 25 deg. caster	pr	4.50
	6220	ALUMINUM FRONT INLINE AXLES. Axle thread is now 5-40, not 4-40. Uses #6222 black nylon locknut	pr	6.00
	6221	INLINE STEERING BLOCKS, for alum. axles	pr	2.00
	6222	SELF-THREADING NYLON LOCKNUT, for #6220 axles	8	2.00
	6223	KINGPINS with clips, 1.00"	pr	2.00
	7209	HINGE PINS, inner, with clips, 1.675"	pr	2.50
	6227	HINGE PINS, outer, with clips, 1.020"	pr	2.50
	7214	TRUCK FRONT SHOCK STRUT	1	5.00
	7240	REBUILD KIT (screws, clips, pins etc.)	1	12.00
	7253	TURNBUCKLE, upper control rod, tie rod, 2.620"	pr	3.00
	6270	BALL JOINTS, .17 ball w/male 4-40 thread	2	2.50
	6273	BALL JOINTS, .17 ball with male 4-40 thread, with cups. .10" longer thread than #6270	2	2.50
	6280	ALUM. FLAT HEAD Machine screw, 8-32 X 1/2	16	2.00
	6285	SOCKET HEAD Cap screw, 4-40 X 1/4" steel	12	2.00
	6291	FLAT HEAD Socket screw, 4-40 X 1/4"	6	2.00
	6295	4-40 NUTS, 6 each plain, lock and nylon	18	2.00
	6925	SOCKET HEAD Cap screw, 4-40 X 1/2"	6	2.00
	6927	SOCKET HEAD Cap screw, 4-40 X 3/4"	6	2.00
	6936	ALUMINUM WASHER, #4	10	1.00
	6951	SET SCREWS, 4-40 x 1/8", with wrench	6	2.50
	7260	THIN PLAIN NUT, 4-40, for ball ends	12	2.00
	7420	SOCKET HEAD Cap screw, 4-40 x 5/8", special (truck front lower shock screw)	2	.75

STEERING LINKAGE

	7251	TURNBUCKLE, 1.0"	1	1.50
	7253	TURNBUCKLE, upper control rod, tie rod, 2.620"	2	3.00
	7531	SERVO SAVER, Gas truck, plastic only	pr	2.50
	7532	SERVO SAVER KIT COMPLETE, gas truck	1	10.00
	7257	SERVO SAVER SPRING & adjusting nut	1	2.00
	7258	SERVO SAVER THREADED TUBE	1	2.50
	6222	SELF-THREADING NYLON LOCKNUT, for #6220 axles	8	2.00
	6270	BALL JOINTS, .17 ball, male 4-40 thread, cups	2	2.50
	6271	BALL JOINTS, .17 ball, male 4-40 thread, cups	12	10.00
	6273	BALL JOINTS, .17 ball, male 4-40 thread, .10" longer thread than #6270, with cups	2	2.50
	6274	BALL CUPS, spares for #6270, #6271, #6273, nylon	14	5.00
	6936	ALUMINUM WASHER, #4	10	1.00
	7260	THIN 4-40 NUTS, for ball ends	12	2.00
	7633	BUTTON HEAD Socket screw, 4-40 X 5/8"	6	2.00
	7658	FLAT HEAD Machine screw, 8-32 X 3/8"	6	2.00
	7672	FLAT HEAD Socket screw, 4-40 X 7/8"	6	2.00
	7738	SOCKET HEAD Cap screw, 4-40 X 7/8"	2	1.00

qty	part no.	description	pkg	list price	qty	part no.	description	pkg	list price
-----	----------	-------------	-----	------------	-----	----------	-------------	-----	------------

CHASSIS PARTS

7525	GAS TRUCK TUB CHASSIS, aluminum, black anodized	1	30.00
6312	CLEAR CHASSIS PROTECTIVE SHEET to protect the chassis finish	1	6.50
7305	NOSE PLATE, black anodized	1	9.00
7306	TRUCK NOSE PLATE SCREW SET	1	2.00
7315	NOSE BRACE TUBES, black anodized, with screws	pr	5.50
7526	REAR BULKHEAD, gas truck	1	3.00
7318	FRONT BODY MOUNT BRACE	1	2.50
7319	FRONT BODY MOUNTS	pr	1.50
7320	NYLON WASHERS, BODY MOUNT, large	4	.75
7323	REAR BODY MOUNTS with screws	pr	2.00
6332	HOOD PINS	6	.50
7324	FRONT BUMPER, nylon	1	2.50
7527	SERVO MOUNTS, gas truck	2pr	2.50
7528	ANTENNA/RECEIVER MOUNT	1	2.00
7529	REAR BUMPER, gas truck	1	3.50
7530	FOAM PAD, for mounting receiver battery pack	1	1.50
6726	SERVO TAPE, black roll, 36" length	1	2.50
6285	SOCKET HEAD Cap screw, 4-40 X 1/4", steel	12	2.00
6918	SOCKET HEAD Cap screw, 4-40 X 5/16"	6	2.00
6924	SOCKET HEAD Cap screw, 4-40 X 3/8"	6	2.00
6925	SOCKET HEAD Cap screw, 4-40 X 1/2"	6	2.00
6932	SOCKET HEAD Cap screw, 4-40 X 5/16"	6	2.00
6936	ALUMINUM WASHER, #4	10	1.00
7260	THIN PLAIN NUT, 4-40	12	2.00
7673	FLAT HEAD Socket screw, 4-40 X 5/16"	6	2.00
7874	SOCKET HEAD Cap screw, 4-40 X 7/16	8	2.50

REAR SUSPENSION

6372	DOGBONE SPRINGS & SPACERS	4	.50
6373	REAR AXLE SHIMS, 1/4" ID X .010" thick, for #7362 and 6371 axles	14	1.50
6374	REAR STUB AXLE with roll pin	1	5.00
6375	ROLL PIN for stub axle	6	.50
6388	CONE WASHER, 1/4" x .400 x .006	4	1.00
7355	TRUCK REAR A-ARMS NEW black composite material	pr	7.00
7356	REAR A-ARM HINGE PIN, inner; clips, 2.084"	pr	3.00
7357	REAR A-ARM HINGE PIN, outer; clips, 1.205"	pr	2.50
7359	BALL BEARINGS, 1/4" x 3/8" unflanged, rear hub carriers	pr	14.00
7360	UNFLANGED BUSHING, 1/4 X 3/8"	4	2.00
7361	DOGBONE (rear half shaft)	1	7.00
7362	TRUCK UNIVERSALS	pr	33.00
7365	REAR HUB CARRIERS, 0 deg. toe-in per side (uses 1/4" x 3/8" unflanged bearings)	pr	3.50
7650	REAR SUSPENSION KIT COMPLETE, gas truck	1	37.00
7651	REAR SUSPENSION MOUNTS, gas truck, 3 deg. toe-in per side	pr	2.00
7655	REAR SHOCK STRUT, fiberglass	1	5.50
7657	REAR SHOCK MOUNTS, nylon	2	2.00
7658	FLAT HEAD Machine screw, 8-32 X 3/8", black (for mounting rear bulkhead and suspension mounts to chassis on gas truck)	6	2.00
6295	4-40 NUTS, 6 each unflanged, lock and nylon	18	2.00
6917	BUTTON HEAD Socket screw, 4-40 X 3/8"	6	2.00
6925	SOCKET HEAD Cap screw, 4-40 X 1/2"	6	2.00

6927	SOCKET HEAD Cap screw, 4-40 X 3/4"	6	2.00
6936	ALUMINUM WASHER, #4	10	1.00

GAS TRUCK STEALTH TRANSMISSION

6563	STEALTH TRANSMISSION BALL BEARING SET Eight bearings and one bushing	1	52.00
7661	TRANSMISSION CASE, gas truck	1	6.00
6568	SPUR GEAR SCREWS	4	1.50
6570	IDLER SHAFT & GEAR SET	set	3.50
6571	DRIVE GEAR/SHAFT ASSEMBLY, roll pin	1	9.00
7665	DRIVE SHAFT ROLL PIN, gas truck	6	1.00
7669	DRIVE SHAFT SPACER	6	2.00
6573	DIFF THRUST WASHER	2	2.50
6574	PRECISION THRUST BALLS, 5/64"	6	2.00
6575	DIFF THRUST BOLT, Thrust Bearing Cover, Dogbone Spacers & Locking T-nut	set	2.00
7667	DIFF OUTDRIVE HUB, right	1	7.50
7668	DIFF OUTDRIVE HUB, left	1	7.50
7666	DIFF DRIVE RINGS, gas truck	2	1.50
7664	DIF GEAR, gas truck	1	2.50
7670	TRANSMISSION BRACE, gas truck	1	2.00
6581	CARBIDE DIFF BALLS, large 3/32"	12	12.00
6582	DIFF THRUST SPRING	1	1.50
6583	TORQUE CONTROL HUB, inner	1	7.50
6584	TORQUE CONTROL HUB, outer	1	7.50
6585	RULON CLUTCH DISK	1	3.00
6594	THRUST BEARING WASHER, replaces #6586 thrust bearing	set	2.00
6587	TORQUE CONTROL SPRING & LOCKNUT	set	1.50
7662	64 TOOTH, 32 PITCH SPUR GEAR gas truck	1	4.00
7663	66 TOOTH, 32 PITCH SPUR GEAR gas truck	1	4.00
6588	BLACK GREASE	1	2.50
6589	5/32" x 5/16" BALL BEARING, unflanged	pr	13.00
6591	STEALTH DIFF LUBE	1	2.50
6592	ALLEN WRENCH SET	set	2.50
6595	COMPLETE BUSHING SET FOR STEALTH TRANSMISSION	9	5.00
6596	3/16" x 5/16" BUSHING, unflanged	2	1.00
6597	5/32" x 5/16" BUSHING, unflanged	2	1.00
6598	3/8" x 5/8" BUSHING, unflanged	2	1.50
6599	3/16" x 3/8" BUSHING, unflanged	4	2.00
6903	3/8" x 5/8" BALL BEARING, unflanged, sealed	pr	20.00
6906	3/16" x 3/8" BALL BEARING, unflanged	pr	13.00
6924	SOCKET HEAD Cap screw, 4-40 X 3/8"	6	2.00
7672	FLAT HEAD Socket screw, 4-40 X 7/8" (front transmission mounting screw)	6	2.00
7673	FLAT HEAD Socket screw, 4-40 X 5/16" (rear transmission mounting screw)	6	2.00

BRAKE/THROTTLE

7551	BRAKE BRACKET, plated	1	2.50
7552	BRAKE SHOE, plated	1	1.50
7553	BRAKE DISC, fiber	1	4.00
7554	DISC BRAKE ADAPTER, plastic	1	1.00
7555	DISC BRAKE CAM, steel	1	3.00
7556	BRAKE CAM CLIP (push nut)	6	1.50
7557	THROTTLE PIVOT, aluminum	1	2.00
7558	THROTTLE PIVOT CLIP (push nut)	6	1.50
7559	SERVO HORN ADAPTER, plastic	1	1.50
7560	BRAKE/THROTTLE LINKAGE KIT, complete	1	9.00
3721	SELF-TAPPING screw, 2-56 X 1/4"	12	1.00
6919	BUTTON HEAD Socket screw, 4-40 X 5/16"	6	2.00

qty	part no.	description	pkg	list price	qty	part no.	description	pkg	list price
-----	----------	-------------	-----	------------	-----	----------	-------------	-----	------------

CLUTCH

	7601	CLUTCH SHOE, Teflon	pr	7.00					
	7603	CLUTCH NUT (fits Yokomo Dynamite and new OS Max)	1	5.00					
	7604	CLUTCH NUT, special (fits OS Max crankshafts made before Oct. 1993)	1	5.00					
	2661	CLUTCH NUT CLIPS	6	.75					
	7605	15 TOOTH, 32 PITCH CLUTCH BELL, steel. Recommended gear for small, tight, off road tracks.	1	8.00					
	7606	16 TOOTH, 32 PITCH CLUTCH BELL, steel. Recommended gear for larger off road tracks.	1	8.00					
	7607	17 TOOTH, 32 PITCH CLUTCH BELL, steel. For use on oval track racing (will not fit pull start engines)	1	8.00					
	7608	18 TOOTH, 32 PITCH CLUTCH BELL, steel. For use on large oval track racing (will not fit pull start engines). WARNING: May require aftermarket parts and modification to truck.	1	8.00					
	6902	BALL BEARING, 3/16 X 5/16", flanged	pr	14.00					
	6863	BUSHING, 3/16 X 5/16", for two rims	4	1.00					
	7610	FLYWHEEL, non-pull start engine (Yokomo, Dynamite, OS Max)	1	8.00					
	7611	NEW! RACING FOUR SHOE FLY-WHEEL, requires two #7601 clutch shoe sets, not included	1	10.00					
	7612	FLYWHEEL, pull start engine (Yokomo, Dynamite, OS Max)	1	8.00					
	7618	FLYWHEEL COLLET, with spacer shim	1	3.00					
	7619	FLYWHEEL PIN	2	1.00					
	7620	SPECIAL CUT OFF NUT, for cutting crankshaft to correct length for clutch nut installation (Yokomo, Dynamite and OS Max)	1	2.50					

SHOCKS

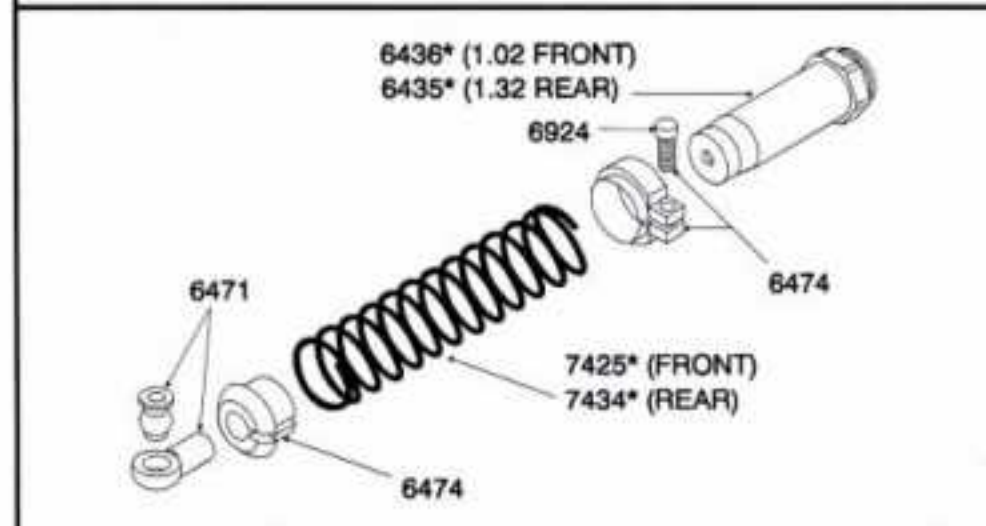
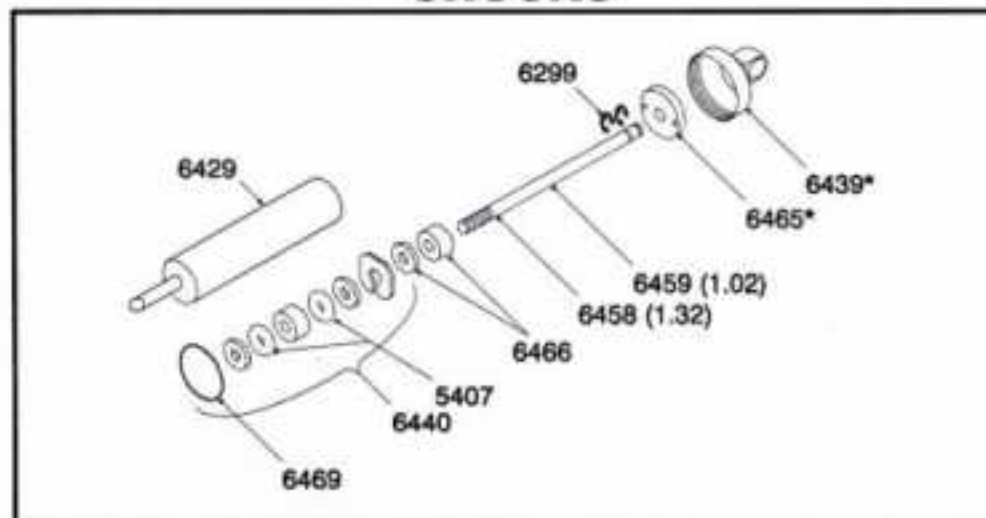

GOLD, STANDARD

	6420	SHOCK SET, rear, 1.32, STANDARD	pr	25.00					
	6421	SHOCK SET, front, 1.02, STANDARD	pr	25.00					
	6424	SHOCK BODY, rear, 1.32, STANDARD	1	6.75					
	6425	SHOCK BODY, front, 1.02, STANDARD	1	6.75					
	6428	END CAP, plastic	1	2.25					
	6429	SHOCK ASSEMBLY TOOL	1	1.00					

GREY, RACING HARD ANODIZED, TEFLON SEALED

	6431	SHOCK SET, rear, 1.32, RACING	pr	30.00					
	6432	SHOCK SET, front, 1.02, RACING	pr	30.00					
	6435	SHOCK BODY, rear, 1.32, RACING	1	8.50					
	6436	SHOCK BODY, front, 1.02, RACING	1	8.50					
	6439	SHOCK END CAP, aluminum black anodized	1	3.00					
	6429	SHOCK ASSEMBLY TOOL	1	1.00					

PARTS FOR ALL SHOCKS

	5407	RED SILICONE "O" RINGS only, as used in rebuild kits #6440 and #6467	8	2.00					
	6440	REBUILD KIT, for for 4 shocks	set	4.00					
	6458	SHOCK SHAFT 1.32 Stroke	1	3.00					
	6459	SHOCK SHAFT 1.02 Stroke	1	3.00					
	6464	PISTONS, all 0.4 bore shocks	4	3.00					
	6465	SHOCK PISTON, 4 each of #1, #2 & #3 to adjust dampening	12	7.00					
	6469	O-RINGS, shock end caps-to-body seals	4	1.50					
	6470	MOUNTING KIT, with rod ends, for 2 shocks	1	4.50					
	6471	ROD ENDS for 2 shocks, .230 ball	pr	3.00					
	6473	SHOCK BUSHINGS	4	1.00					
	6474	SPRING CLAMPS & CUPS, 4 sets	4	3.00					
	7660	REAR SHOCK/TURNBUCKLE steel ball end with nylon eyelet	pr	3.00					
	6222	SELF-THREADING NYLON LOCKNUT, for #6220 axles	8	2.00					
	6295	NUTS, 4-40, 6 each plain, lock, and nylon	18	2.00					
	6924	SOCKET HEAD Cap screw, 4-40 X 3/8"	6	2.00					
	6925	SOCKET HEAD Cap screw, 4-40 X 1/2"	6	2.00					
	6927	SOCKET HEAD Cap screw, 4-40 X 3/4"	6	2.00					
	7260	THIN NUTS, 4-40, for ball ends	12	2.00					
	7420	SOCKET HEAD Cap screw, 4-40 x 5/8", special (truck front lower shock screw)	2	.75					

PRECISION RACING SPRINGS

	7429	SPRINGS, front, blue, soft	pr	1.50					
	7425	SPRINGS, front, gold, standard	pr	1.50					
	7430	SPRINGS, front, red, firm	pr	1.50					
	7434	SPRINGS, rear, blue, soft	pr	1.50					
	7435	SPRINGS, rear, gold, standard	pr	1.50					
	7436	SPRINGS, rear, red, firm	pr	1.50					

SHOCK OILS

	5410	SHOCK OIL, 140 wt. 1 ounce bottle	1	1.25					
	5412	SHOCK OIL, 50 wt. 1 ounce bottle	1	1.25					
	5413	SHOCK OIL, 40 wt. 1 ounce bottle	1	1.25					
	5414	SHOCK OIL, 30 wt. 1 ounce bottle	1	1.25					
	5415	SHOCK OIL, 20 wt. 1 ounce bottle	1	1.25					
	5416	SHOCK OIL, 10 wt. 1 ounce bottle	1	1.25					
	5420	SILICONE SHOCK OIL, 10 wt. 2 ounce bottle	1	3.50					
	5427	SILICONE SHOCK OIL, 15 wt. 2 ounce bottle	1	3.50					
	5421	SILICONE SHOCK OIL, 20 wt. 2 ounce bottle	1	3.50					
	5428	SILICONE SHOCK OIL, 25 wt. 2 ounce bottle	1	3.50					
	5422	SILICONE SHOCK OIL, 30 wt. 2 ounce bottle	1	3.50					
	5429	SILICONE SHOCK OIL, 35 wt. 2 ounce bottle	1	3.50					
	5423	SILICONE SHOCK OIL, 40 wt. 2 ounce bottle	1	3.50					
	5425	SILICONE SHOCK OIL, 80 wt. 2 ounce bottle	1	3.50					

qty	part no.	description	pkg	list price	qty	part no.	description	pkg	list price
-----	----------	-------------	-----	------------	-----	----------	-------------	-----	------------

ENGINE MOUNT PARTS

	7625	CHASSIS ENGINE MOUNT, black	pr	8.00
	7627	ENGINE MOUNT ADAPTER, for non-pull start engine	pr	11.00
	7629	ENGINE MOUNT ADAPTER, for pull start engine	pr	8.00
	3216	WASHER, #4, steel, (gold colored)	12	1.00
	6292	FLAT HEAD Socket screw, 4-40 X 3/8"	6	2.00
	6924	SOCKET HEAD Cap screw, 4-40 X 3/8"	6	2.00
	6925	SOCKET HEAD Cap screw, 4-40 X 1/2"	6	2.00
	7633	BUTTON HEAD Socket screw, 4-40 X 5/8" (rear engine mount adapter mounting screw)	6	2.00

WHEELS & TIRES

REAR WHEELS & TIRES

	7800	REAR WHEEL, 3 piece, with screws	pr	7.00
	7800B	NEW! TRUCK REAR WHEELS, 3 piece, 2.2", black	pr	7.00
	7800Y	NEW! TRUCK REAR WHEELS, 3 piece, 2.2", florescent yellow	pr	7.00
	7801	ALUM. SOCKET HEAD Cap screw, 4-40 X 5/8"	8	2.50
	7802	REAR WHEEL, one piece, lightweight	pr	7.00
	7802B	NEW! TRUCK REAR WHEELS, 1 piece, 2.2", black	pr	7.00
	7802Y	NEW! TRUCK REAR WHEELS, 1 piece, 2.2", florescent yellow	pr	7.00
	6926	SOCKET HEAD Cap screw, 4-40 x 5/8"	6	2.00
	7820	REAR TIRE, pin spike, center paddle	pr	16.95
	7821	REAR TIRE, mini pin spike	pr	16.95
	7880	TRUCK TIRE INSERT, white	pr	2.00

WIDE FRONT WHEELS & TIRES

	7840	WIDE FRONT WHEEL, 3 piece, with screws	pr	7.00
	7840B	NEW! TRUCK FRONT WHEELS, 3 piece, 2.2", black	pr	7.00
	7840Y	NEW! TRUCK FRONT WHEELS, 3 piece, 2.2", florescent yellow	pr	7.00
	7801	ALUM. SOCKET HEAD Cap screw, 4-40 X 5/8"	8	2.50
	7842	WIDE FRONT WHEEL, one piece, lightweight	pr	7.00
	7842B	NEW! TRUCK FRONT WHEELS, 1 piece, 2.2", black	pr	7.00
	7842Y	NEW! TRUCK FRONT WHEELS, 1 piece, 2.2", florescent yellow	pr	7.00
	6599	FRONT WHEEL BUSHING, 3/16" x 3/8", unflanged	4	2.00
	6926	SOCKET HEAD Cap screw 4-40 x 5/8"	6	2.00
	7870	WIDE FRONT TIRE, block ribbed	pr	16.95
	6906	3/16" x 3/8" BALL BEARING, unflanged	pr	13.00

NARROW FRONT WHEELS & TIRES

	7872	NARROW FRONT WHEEL, 3 piece, screws	pr	6.50
	7871	NARROW FRONT TIRE, 4 ribbed-grooved	pr	13.95
	7873	ALUM. SOCKET HEAD Cap screw 4-40 x 7/16"	8	2.50
	7874	SOCKET HEAD Cap screw 4-40 x 7/16"	8	2.50

	6599	FRONT WHEEL BUSHING, 3/16" x 3/8", unflanged	4	2.00
	6906	FRONT WHEEL BEARING, 3/16" x 3/8", unflanged	pr	13.00

BALL BEARINGS

	7700	COMPLETE BALL BEARING KIT, for RC10T and RC10GT (does not include gas engine clutch ball bearings)	16	95.00
	7701	COMPLETE BALL BEARING KIT, for RC10GT (includes gas engine clutch ball bearings)	18	105.00
	6589	5/32" X 5/16" BALL BEARING, unflanged	pr	13.00
	6901	3/16" X 5/16" BALL BEARING, unflanged	pr	13.00
	6902	3/16" X 5/16" BALL BEARING, flanged	pr	14.00
	6903	3/8" X 5/8" BALL BEARING, unflanged	pr	20.00
	6906	3/16" X 3/8" BALL BEARING, unflanged	pr	13.00
	7359	1/4" X 3/8" BALL BEARING, unflanged	pr	14.00

GAS ENGINE ACCESSORIES

	7705	AIR FILTER KIT, consists of paper filter, foam prefilter, and air filter boot	1	7.50
	7706	PAPER AIR FILTER ELEMENT	1	3.00
	7707	FOAM PREFILTER ELEMENT	4	2.50
	7708	AIR FILTER BOOT	1	3.00
	3719	NYLON WIRE TIES, 6" heavy duty	12	1.25
	3720	NYLON TIES, 8", light duty for receiver	12	1.25
	7709	NYLON WIRE TIES, 4" light duty	12	1.25
	7720	FUEL TANK, plastic, 75cc	1	12.50
	7723	FUEL TANK FITTING	1	4.00
	7724	FUEL TUBING, 15"	1	2.00
	7725	FUEL TUBING, 3 feet	1	4.00
	7729	MUFFLER BRACKET	1	3.00
	7730	MUFFLER, TUNED PIPE	1	21.00
	7733	SILICONE EXHAUST TUBING, 2"	1	2.00
	7734	GASKET, exhaust manifold	3	2.00
	7735	EXHAUST MANIFOLD, for pull start engine (Yokomo, Dynamite and OS Max)	1	12.50
	7736	EXHAUST MANIFOLD, for non-pull start engine (Yokomo, Dynamite and OS Max)	1	12.50
	3216	WASHER, #4	12	1.00
	6242	FRONT WHEEL LOCKNUTS, 4-40	6	1.00
	6292	FLAT HEAD Socket screw, 4-40 X 3/8"	6	2.00
	6928	SOCKET HEAD Cap screw, 4-40 X 1" (for Yokomo exhaust manifold installation)	6	2.00
	7738	SOCKET HEAD Cap screw, 4-40 X 7/8" (for OS Max and Dynamite exhaust manifold installation)	2	1.00

MISCELLANEOUS

The following fasteners include parts not standard on the RC10GT. These are included to meet any needs for custom installations.

LIGHTWEIGHT ALUMINUM & NYLON HARDWARE



A) Button Head B) Flat Head C) Socket Head

	3325	ALUM. FLAT HEAD Machine screw, 8-32 X 1 1/4"	6	1.50
	6280	ALUMINUM FLAT HEAD Machine screw, 8-32 X 1/2"	16	2.00
	6281	ALUM. FLAT HEAD Machine screw 8-32 X 7/8"	6	1.00

