

Buffalo Bobcat

RADIO CONTROLLED RACING OFFROADER

INSTRUCTION AND ASSEMBLY MANUAL

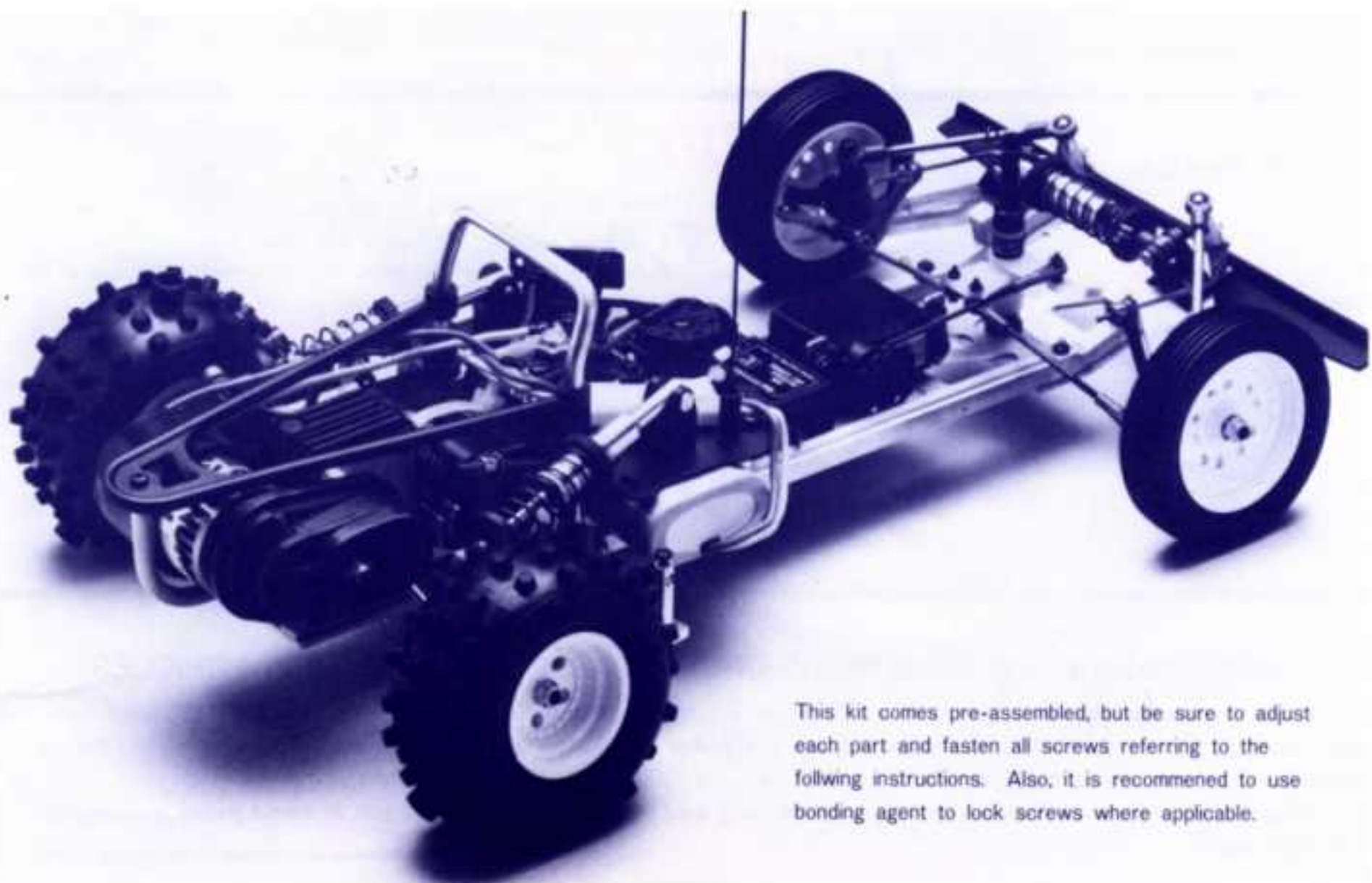

This kit comes pre-assembled, but be sure to adjust each part and fasten all screws referring to the following instructions. Also, it is recommended to use bonding agent to lock screws where applicable.

ayk
ROYAL METAL CO. LTD

AYK RACING

RADIO CONTROL SYSTEM

A 2-channel digital proportional radio is required to operate a RC car. Any standard system can be used, however, 3-8 channel system may not be applicable depending on the receiver size. Rechargeable nickel-cadium batteries (ni-cads), are highly efficient and can be used as many as 300 times or more.

There are two basic types of battery chargers. The more common of the two is a low rate or trickle charger which operates off normal household current and requires approximately 15 hours to fully charge the system. A quick charger is also available, requiring only 15 minutes to fully charge the system. This type of charger operates off a 12 volt power source such as an automobile or motorcycle battery.

NECESSARY ITEMS FOR ASSEMBLY (not included in kit)



TOOLS REQUIRED FOR ASSEMBLY



RADIO CHECK

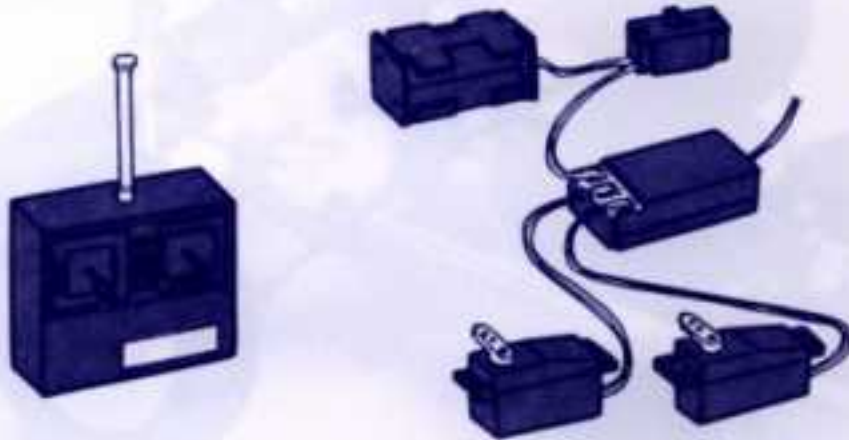

How to set neutral

1. Connect receiver, two servos and power source.
2. Remove the servo horn (note: cut out unnecessary parts of the servo horn)
3. Switch on the transmitter.
4. Set the trim lever of steering controller at the middle position.
5. Turn on the receiver and set up the the servo horn at the proper direction.
6. Turn the receiver off first then the transmitter.

RECOMMENDATION FOR COURTEOUS OPERATION OF RADIO CONTROL VEHICLES

Before switching on the transmitter, make sure that there are no other radio controlled vehicles such as airplanes, cars, boats, etc. are being operated near by. Avoid the same frequency in use if any other radio controlled vehicles are nearby. (check frequency flag on transmitter antenna to find its frequency)

Do not turn on the transmitter while the same frequency is being used by others as it will cause loss of control due to conflicting transmitter signals.

1 Mounting and Adjusting of Steering Servo

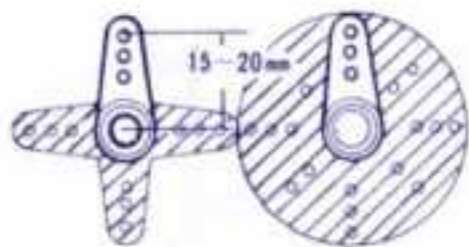

Modify servo arm as shown, removing parts covered by slash mark.

Steering servo



Plug the steering servo into the receiver and set the servo center at the neutral position.

Steering servo rod



Screw ball joint into the steering servo rod.

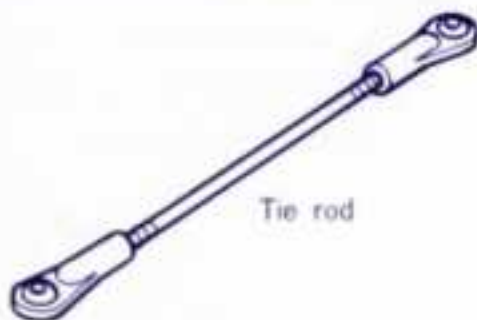

Screw in ball joints from both sides. Make sure the right and left length are the same.

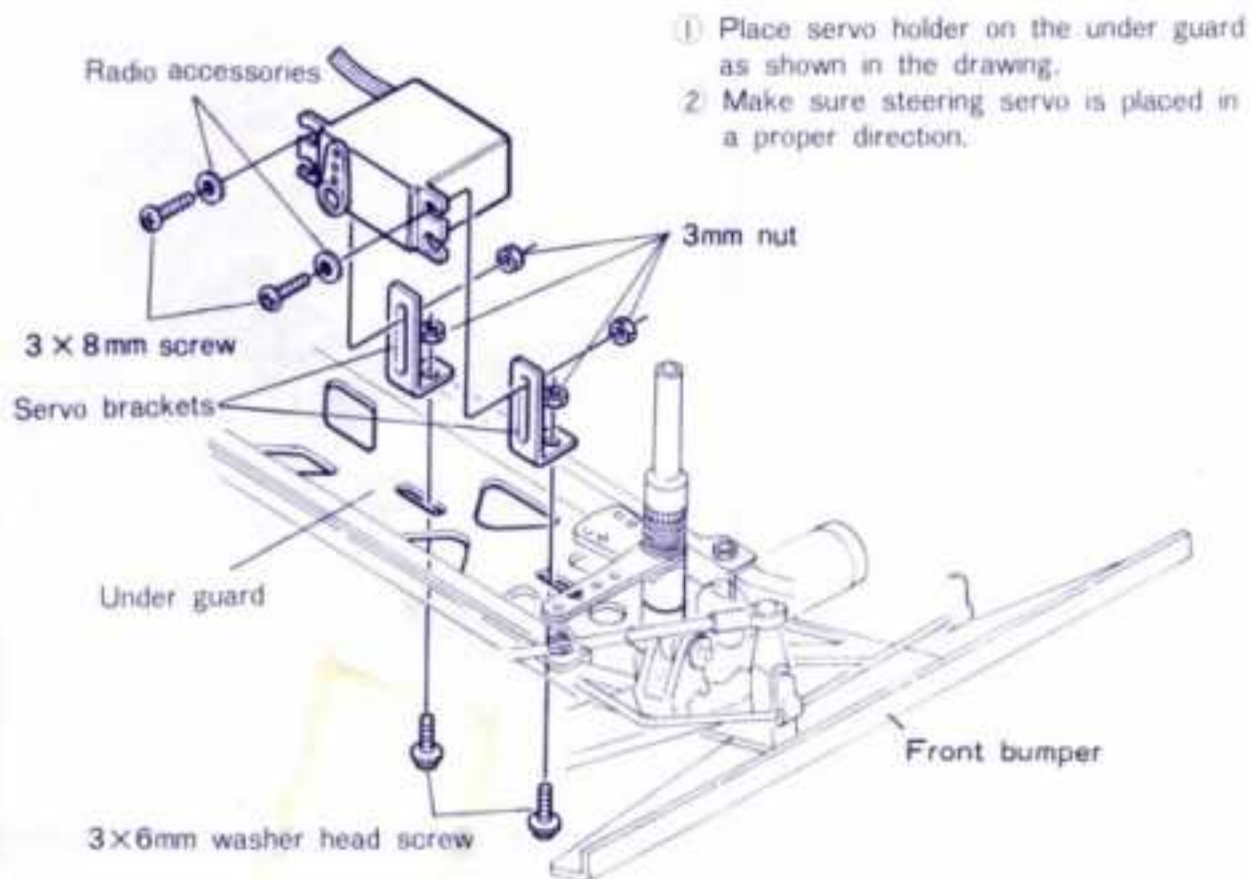

- 1 Place servo holder on the under guard as shown in the drawing.
- 2 Make sure steering servo is placed in a proper direction.

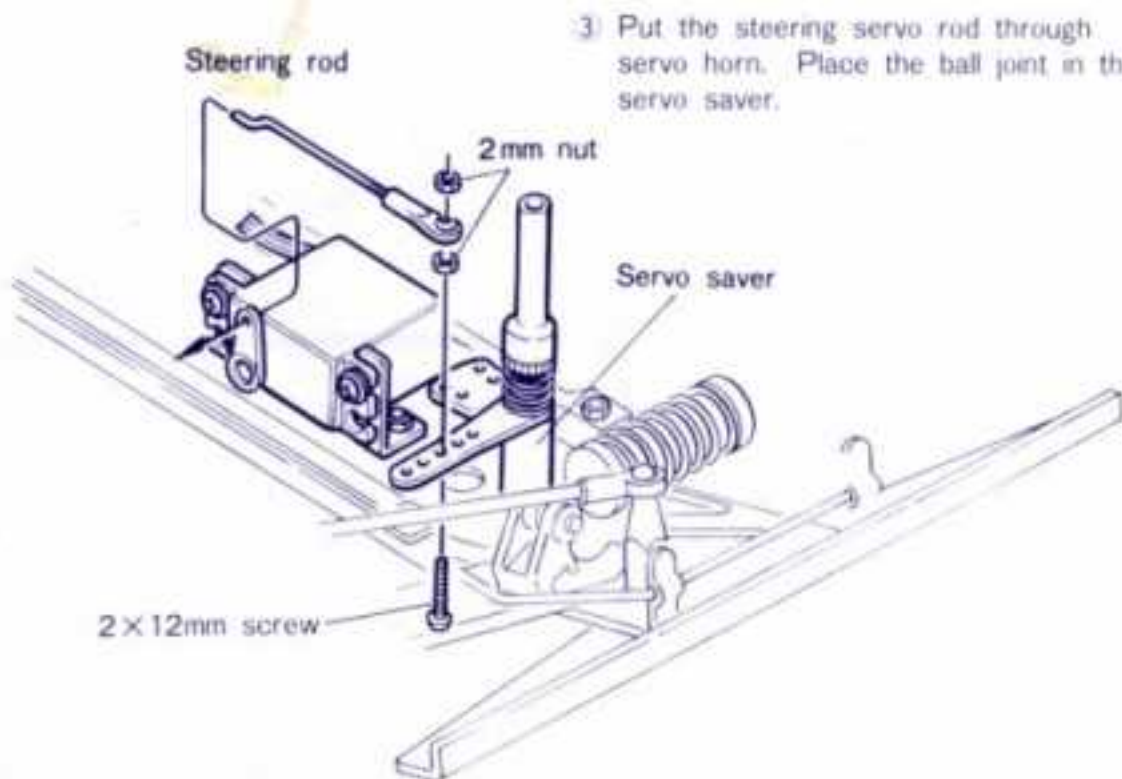

- 3 Put the steering servo rod through servo horn. Place the ball joint in the servo saver.

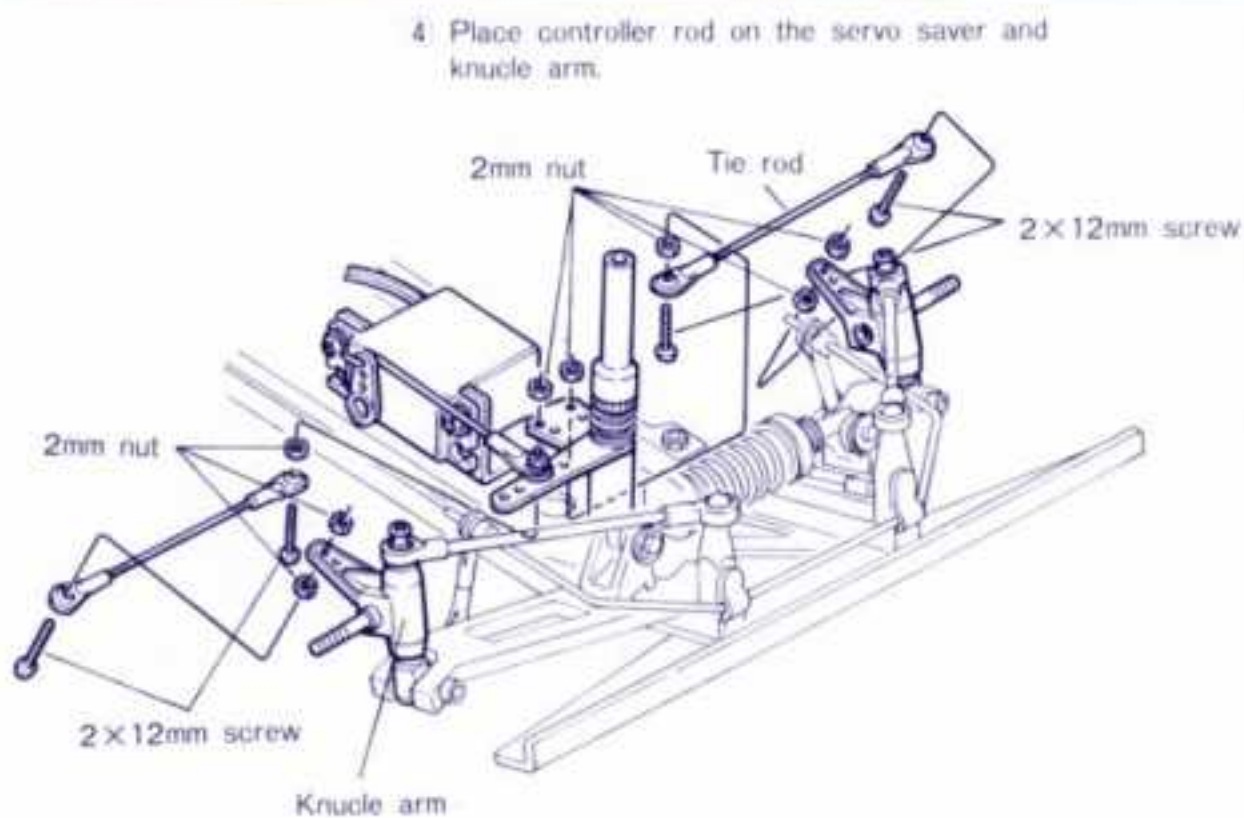

- 4 Place controller rod on the servo saver and knuckle arm.

2 Mounting and Adjusting of Controller Servo

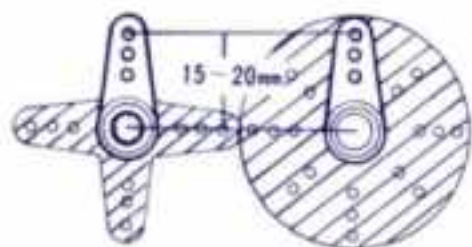

Modify servo horn by removing areas indicated by slash marks.

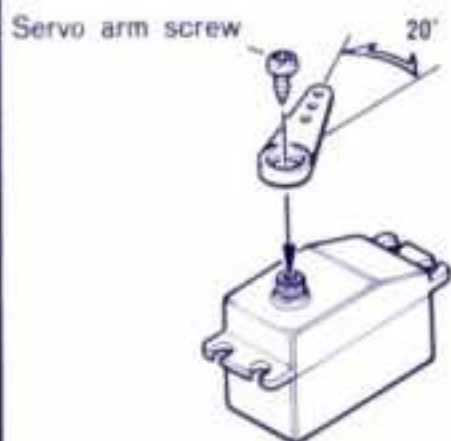

Plug the controller servo into the receiver and adjust servo's center at the neutral position.

Controller servo rod



Screw ball joint in the controller servo rod.

Controller Disassembly Drawing

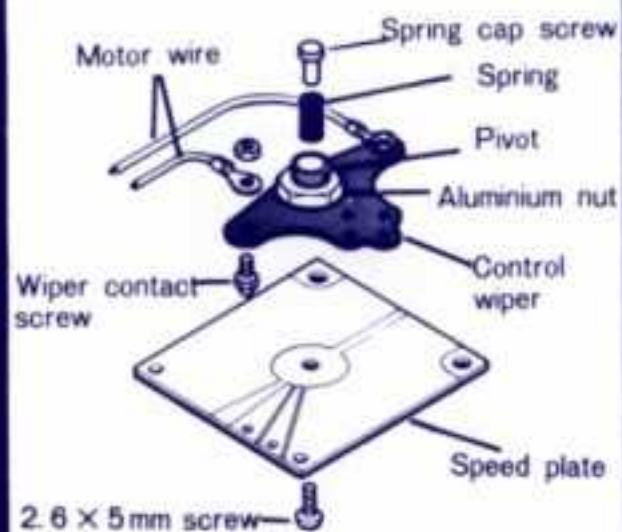

To align for maximum contact, leave space between two gears by allowing a sheet of paper go thru.

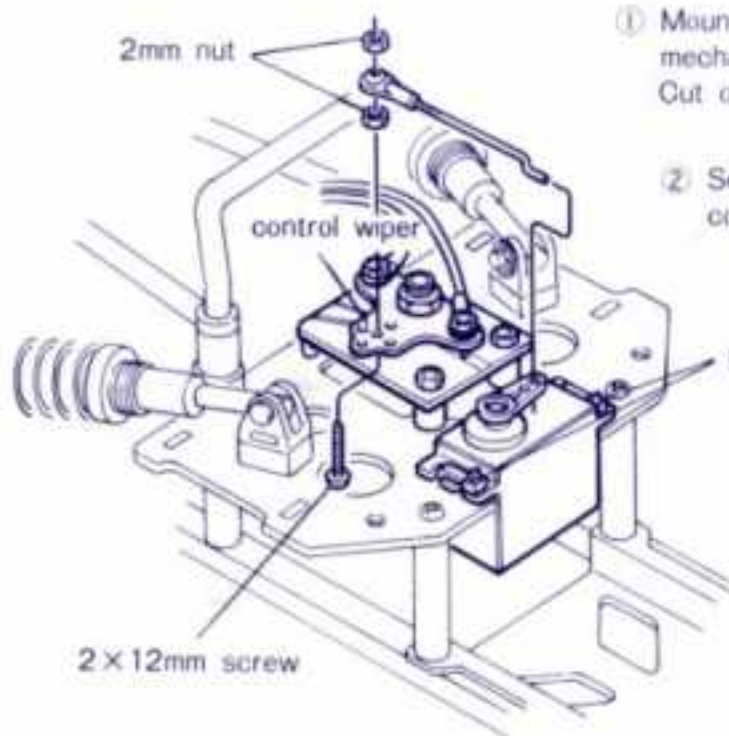

① Mounting the controller servo on the mechanical plate with nylon band (small) Cut off unnecessary nylon band.

② Set the controller servo rod on the control wiper and servo horn.

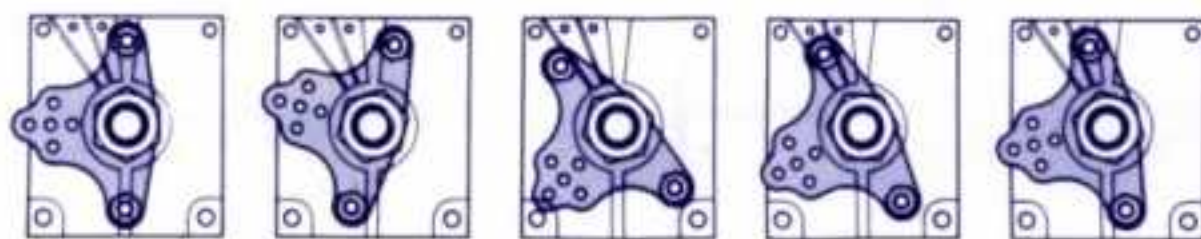
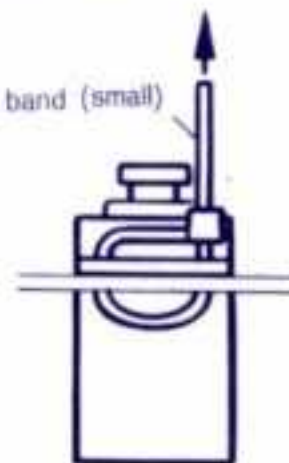

neutral

full-speed/reverse

full-speed/forward

second/forward

low/forward

3 Installation of Motor and Wiring

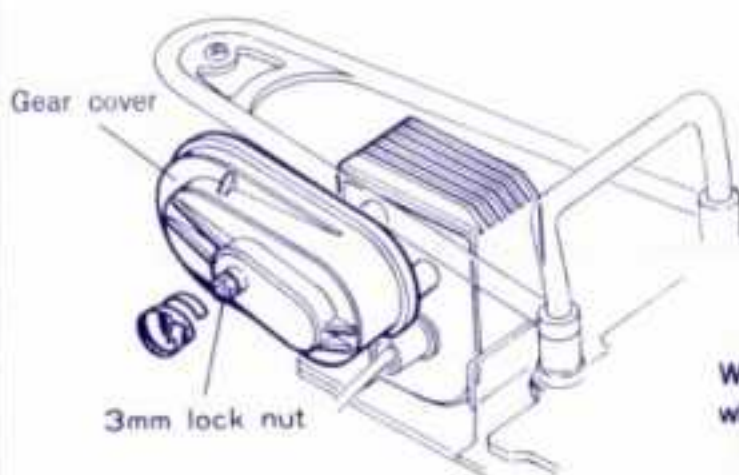

① Unfasten 3mm lock nut and remove the cover.

② Place 14T pinion gear in the motor and fix it on the motor mount watching gears to engage each other well.

③ Make sure to wire + and - correctly to the control wiper.

Wire the red cord to plus (+) and white to minus (-).

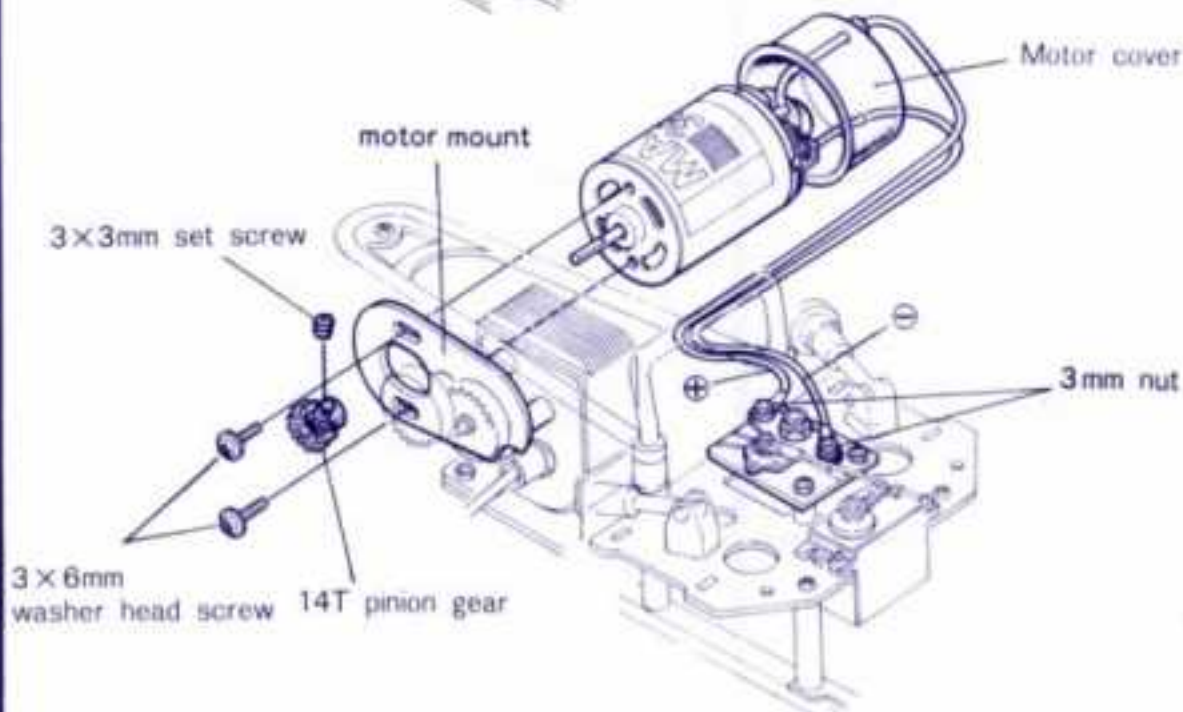

4 Installation of Receiver, Switch, Battery case

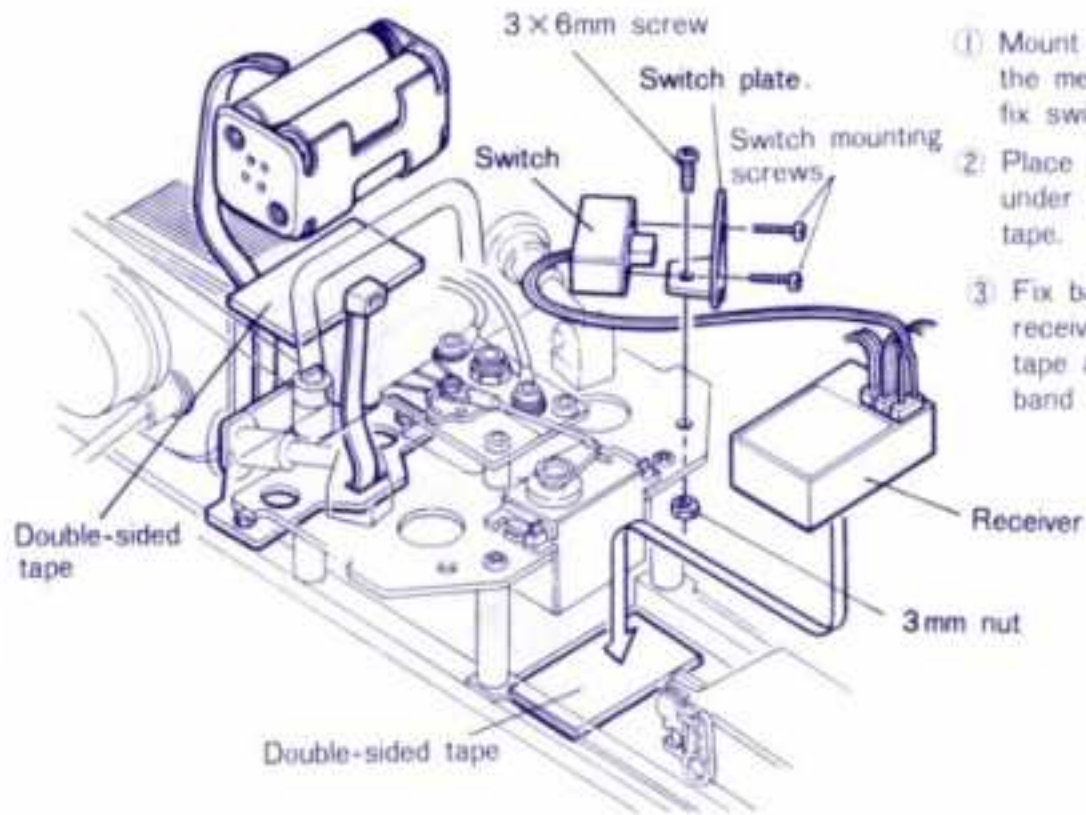
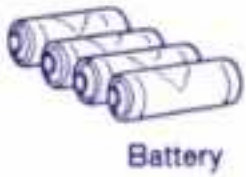

- ① Mount the switch holder on the mechanical plate and fix switch.
- ② Place the receiver on the under guard with double-sided tape.
- ③ Fix battery case for the receiver with double-sided tape and fix it with nylon band (large).

5 Installation of 7.2V/1200m AH Ni-cad Battery Pack

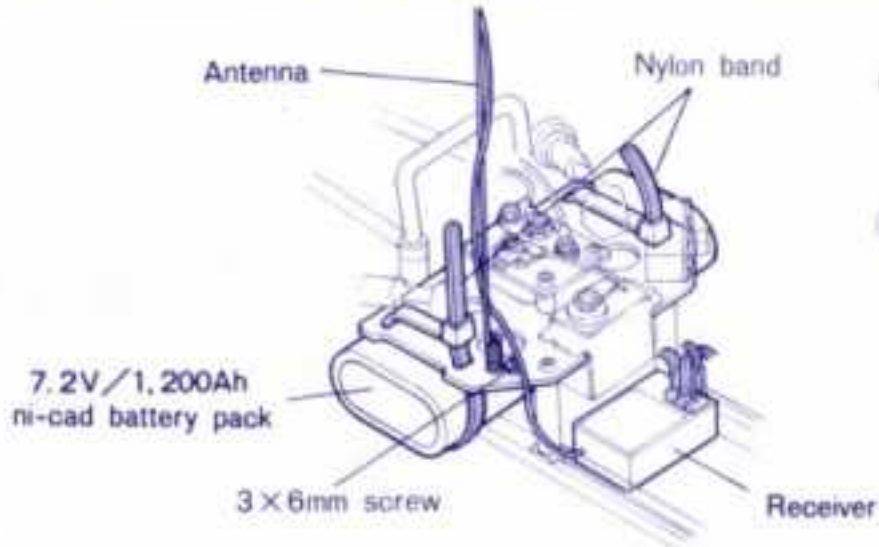

- ① Do not lengthen antenna all way out.
- ② Fix ni-cad battery pack with nylon band (large).

RO-114

Adjusting Gear Case

DIRECTIONS FOR USE OF WASHER FOR DIFFERENTIAL GEAR

16T bevel gear should engage with 22T bevel gear well to prevent damage. Insert one or two washers for adjustment on the right and left side between differential gear and 22T bevel gear

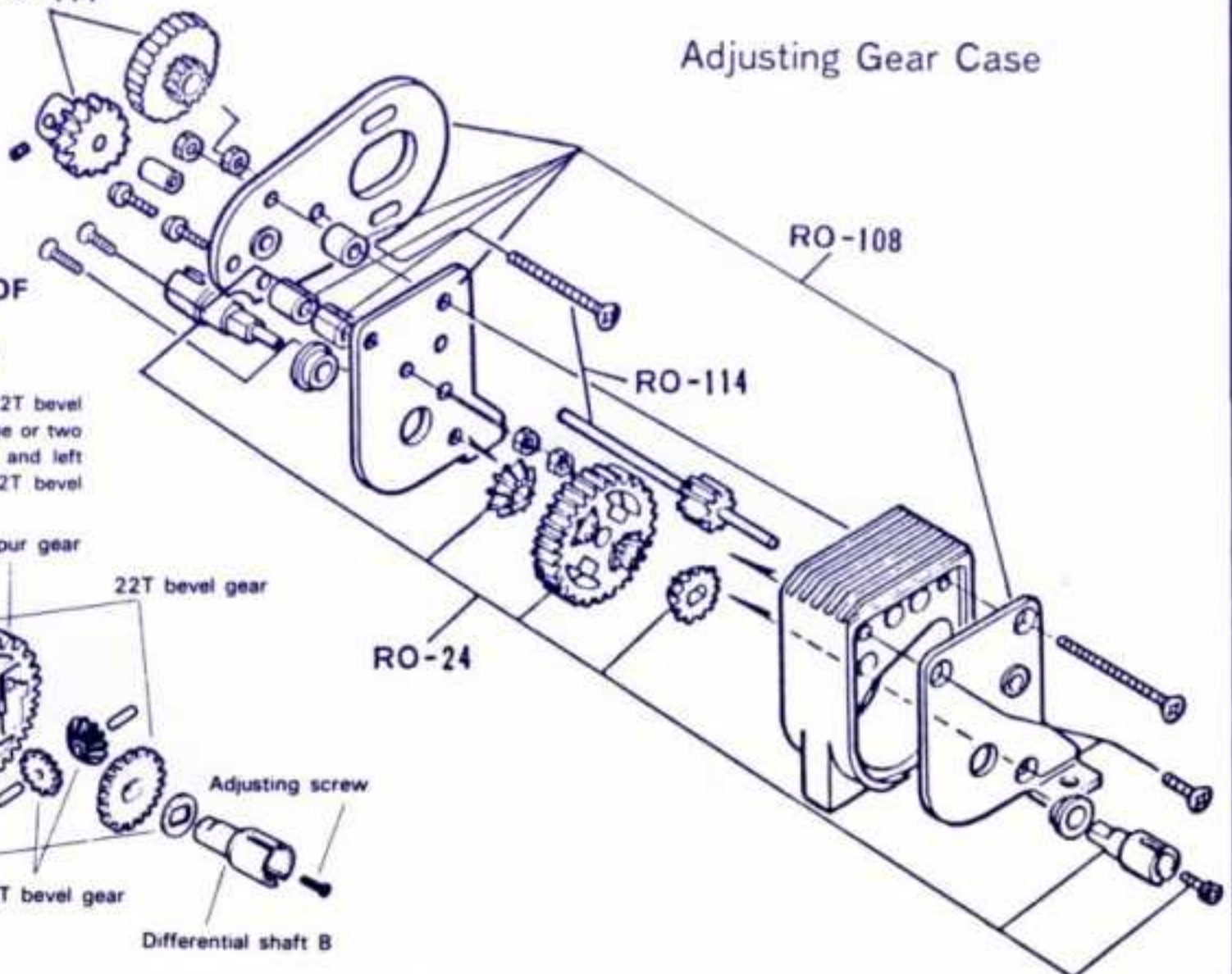
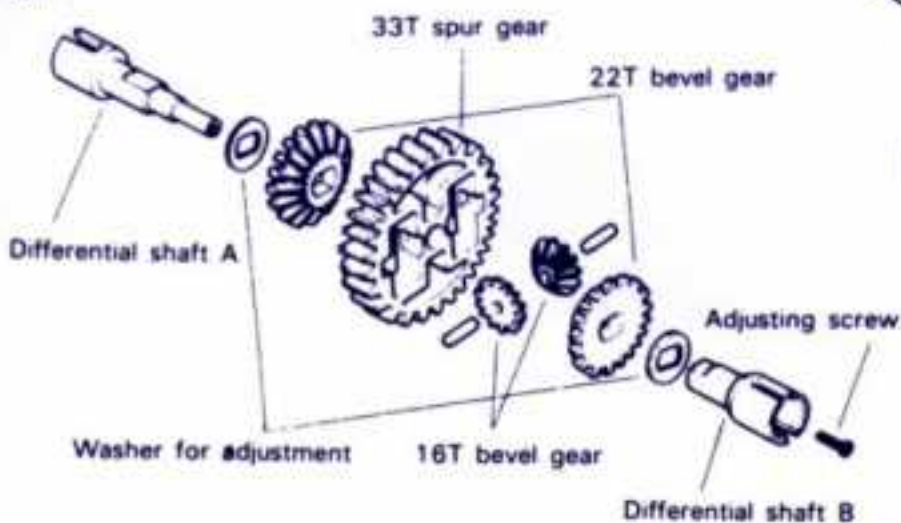

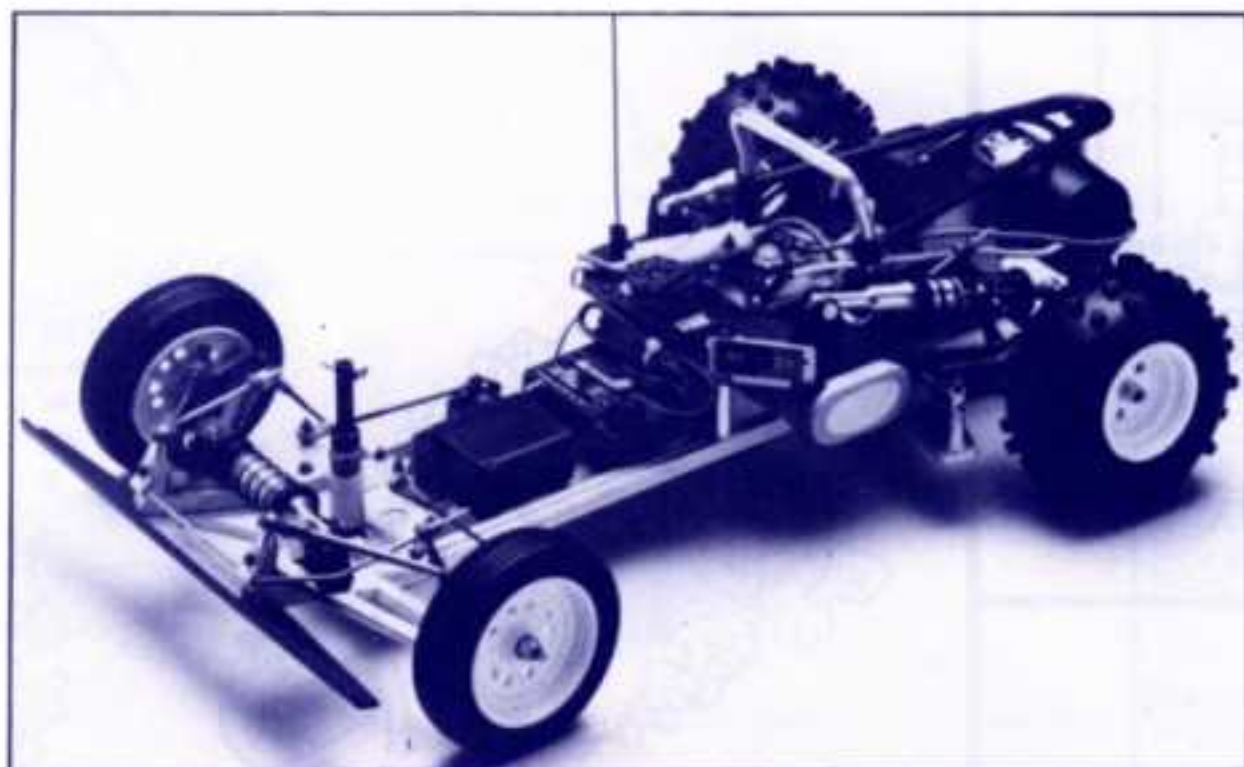
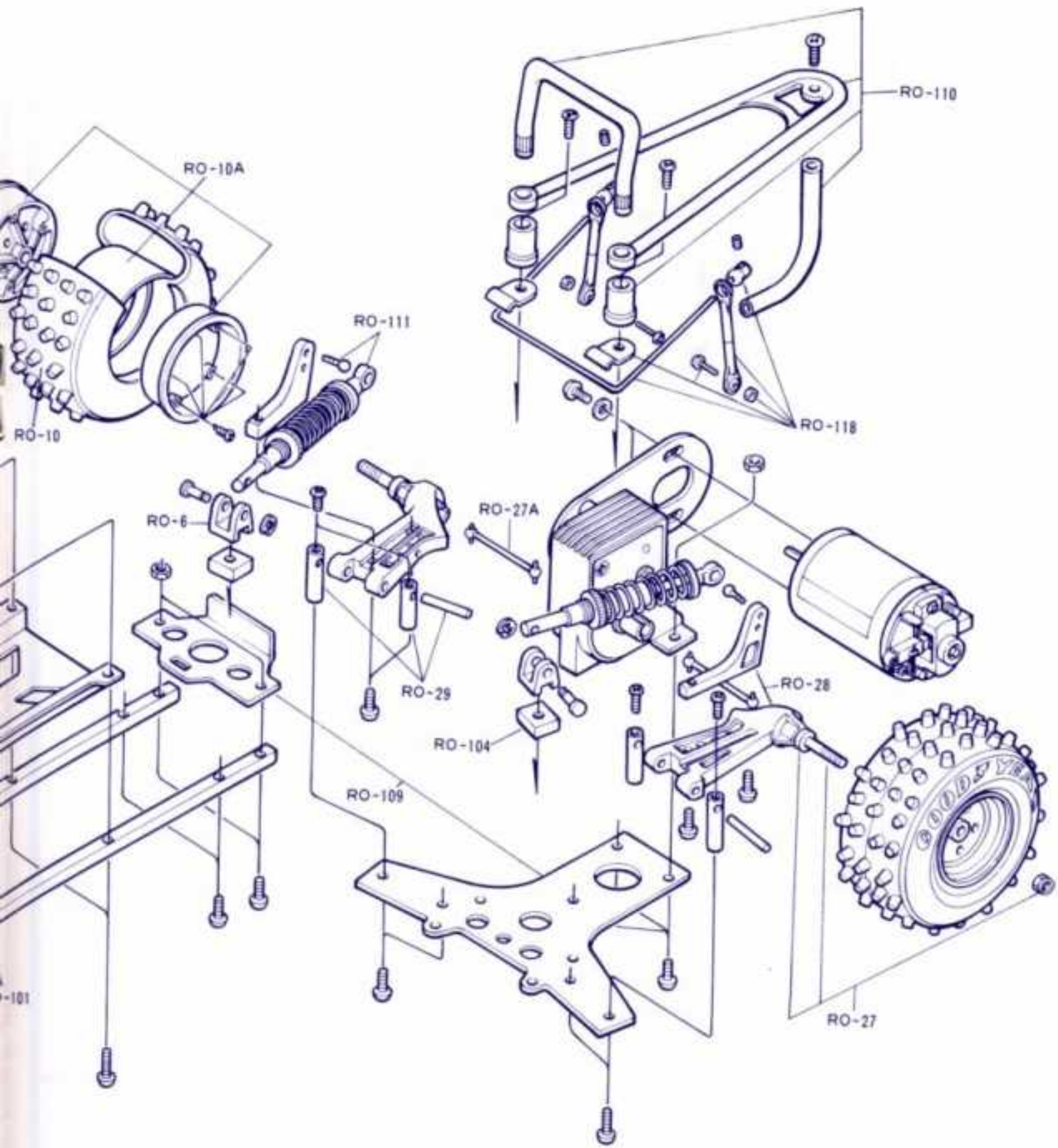

6 Assembly and Adjustment of Shock Absorber

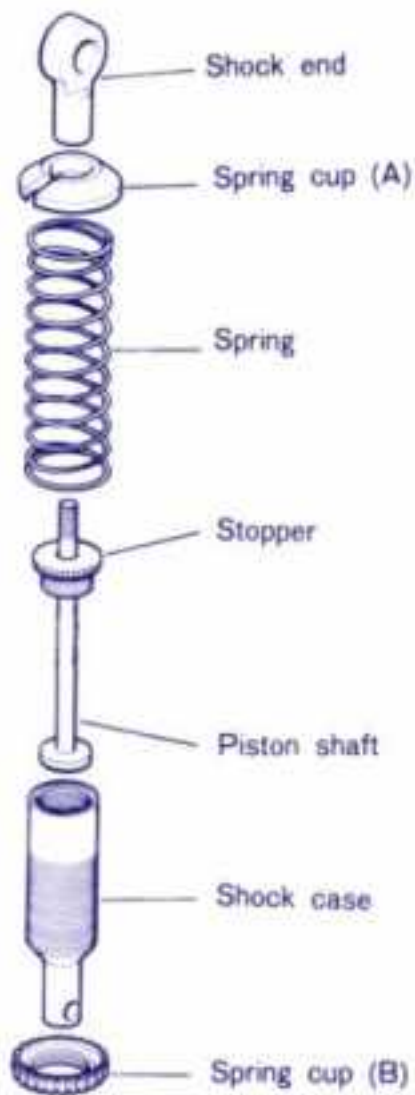

Remove M2.5 E ring and take out both front and rear shock absorbers. As front shock absorber is shown below, do the same for the rear shock.

① push down the spring as shown ② take out the spring, in the drawing, slide out the spring cup A to remove.



③ spin the stopper to remove.



④ Push the piston all way down and pour oil up to the line shown in the drawing in order not to have air bubble inside.



⑤ Tighten the stopper



⑥ Move the piston up and down to see if it moves smoothly.

7 Tire Assembly

Cross-sectional view of the tire

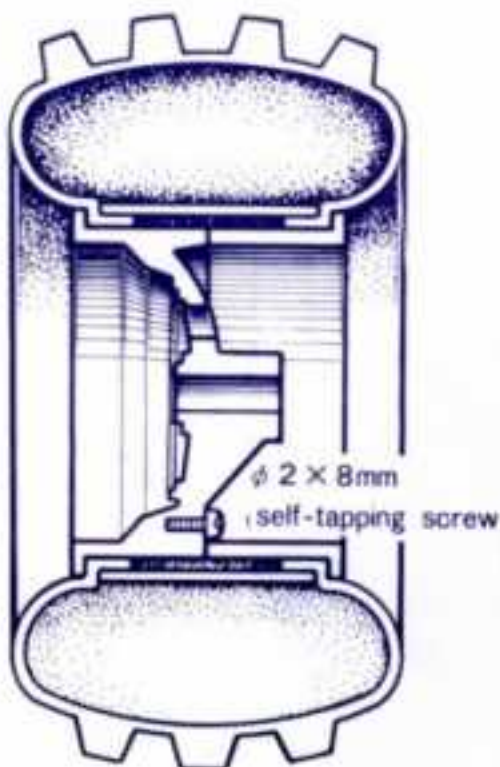

① Place front and rear tires and glue them with instantaneous (Cyano-acrylate adhesive)



② Tighten 4mm lock nut firmly to prevent tires running idle.

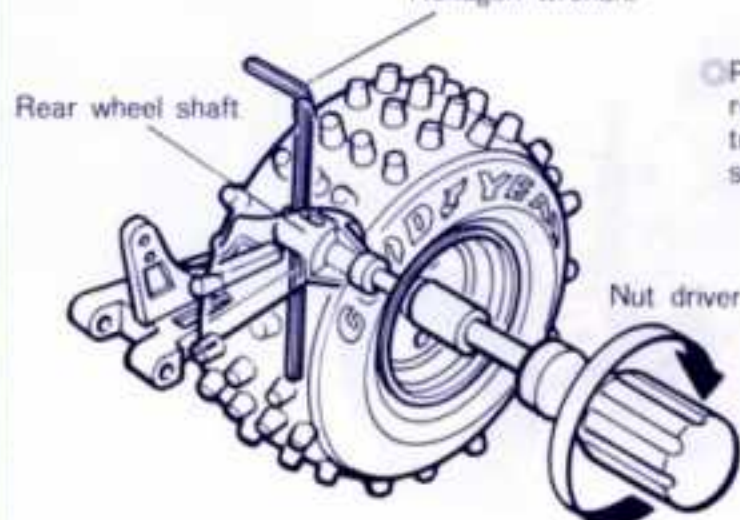

φ 2 × 8mm self-tapping screw

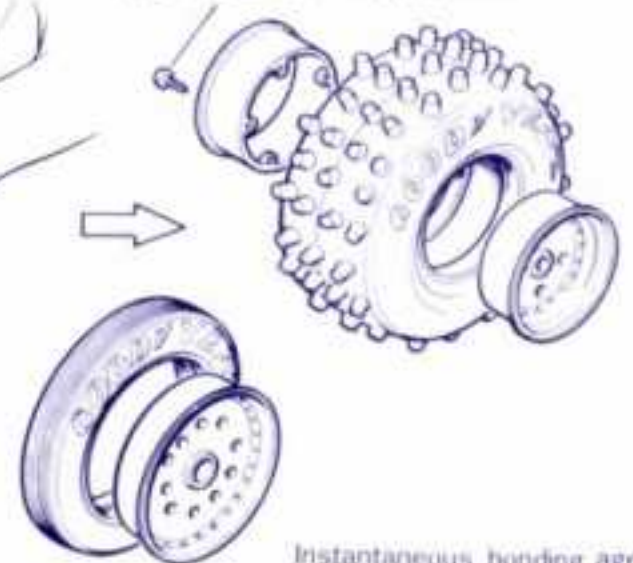

Instantaneous bonding agent (Cyano-acrylate adhesive)

Spike

③ Put spikes on the rear tires in rough track such as sandy soil for better stability.

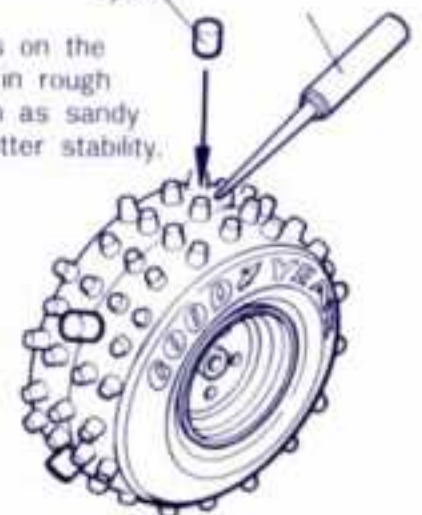

8 Body Trimming and Mounting

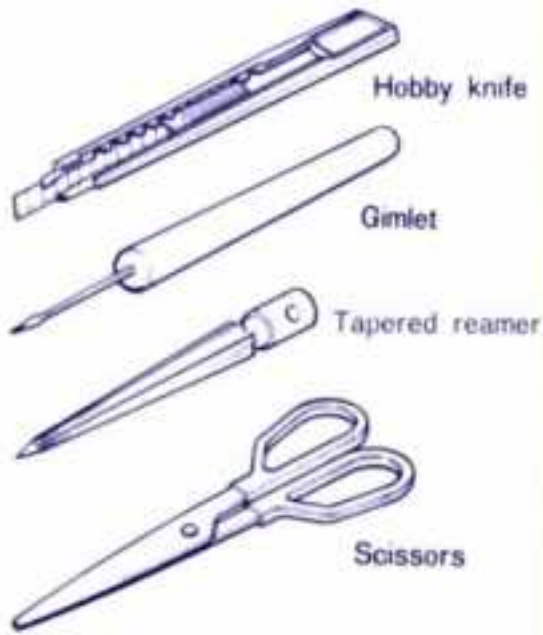

① Trim the body as shown in the drawing and drill holes as marked in a body with a gimlet.

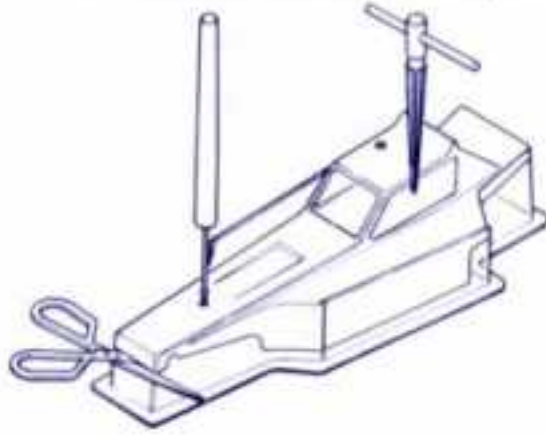

② Wash the inside of the body thoroughly in a neutral detergent water.

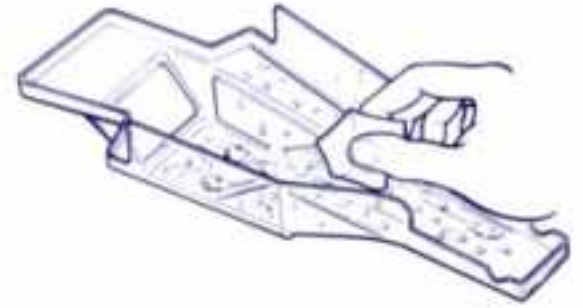

③ Use acrylic paint and/or spray lacquers to paint body.

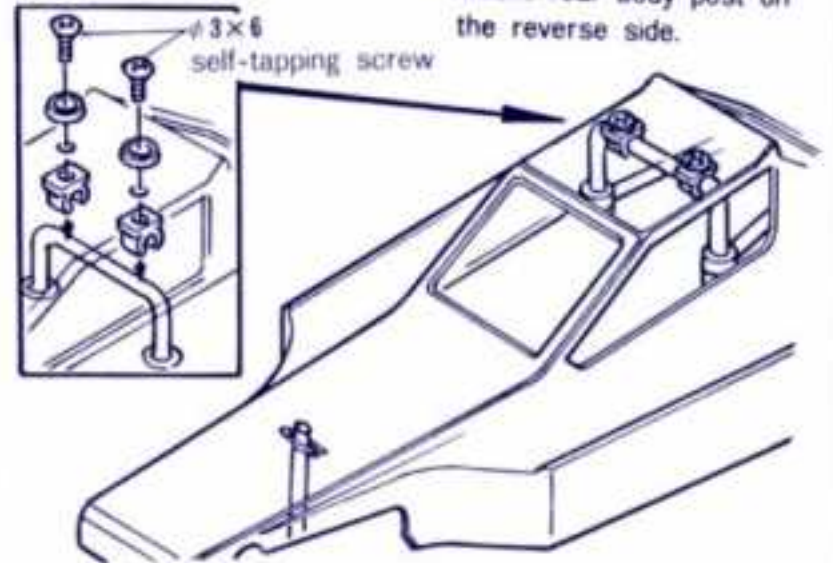
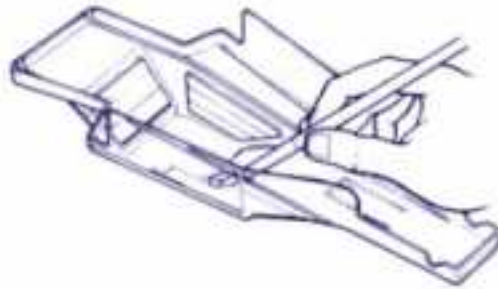

NOTE: CUT OUT THE BACK EDGE OF BODY SHELL FOR THE ROOF WING TO BE ATTACHED TO THE BUFFALO.

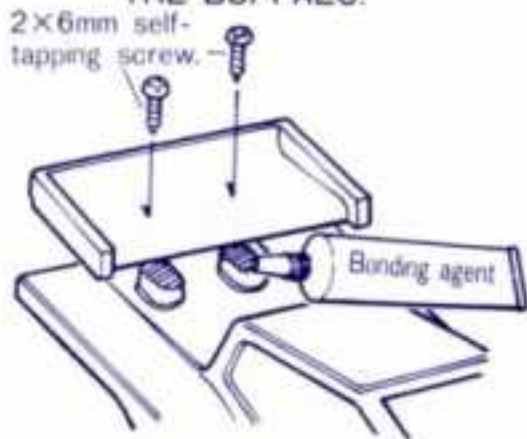

9 Adjustment of Stabilizer

The car is equipped with stabilizer in order to control rolling and slanting of its body for the most efficient racing.

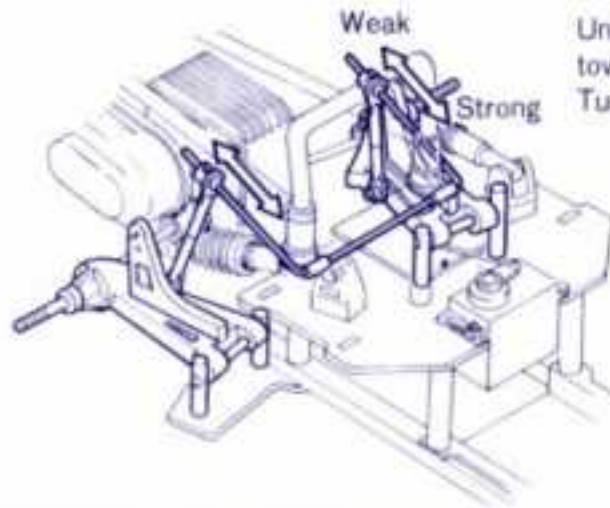

Unfasten $\phi 3 \times 3$ follow screw and move a little toward as an arrow indicates to adjust. Tune properly according to each track condition.

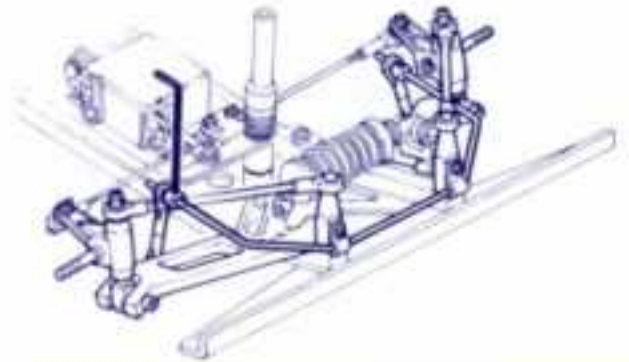

10 Option Parts

RX1200-11 4mm ball bearings

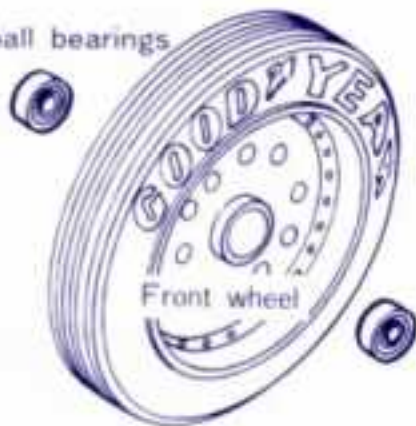

RO-12 6mm ball bearings

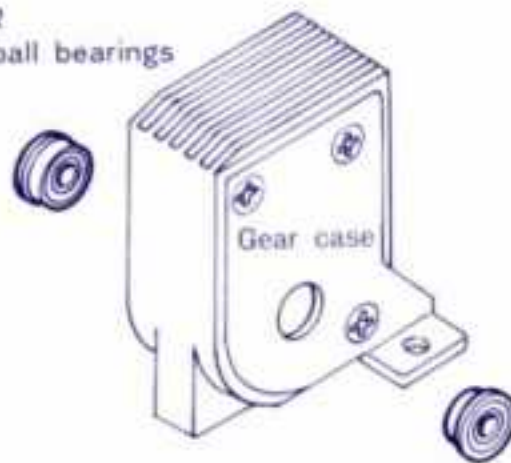

RO-11 5mm ball bearings

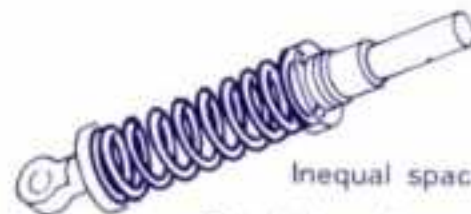









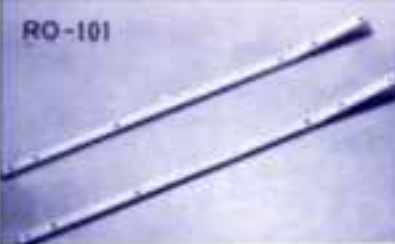









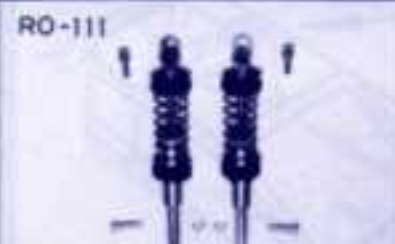
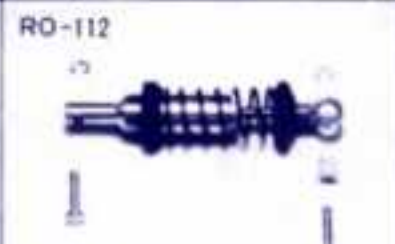

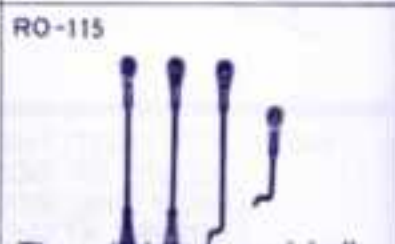

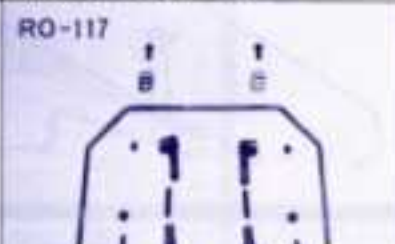











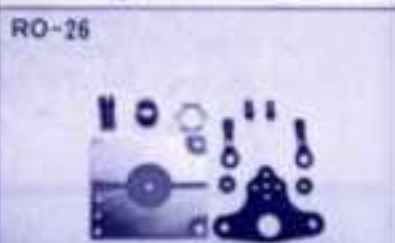
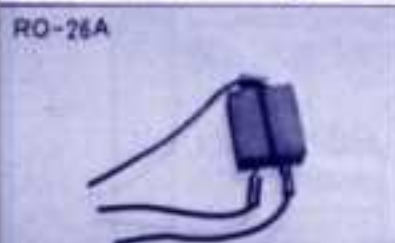

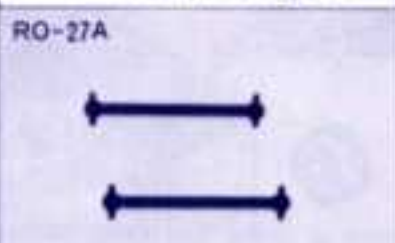



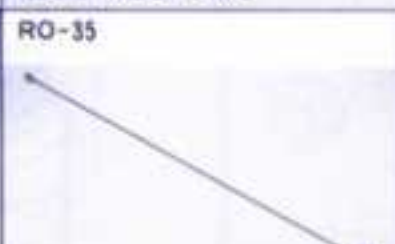
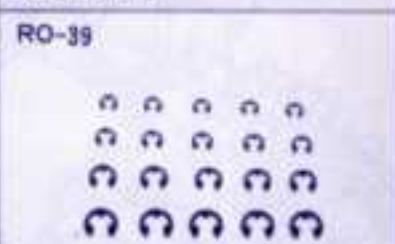





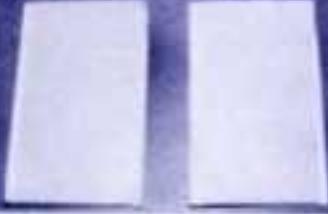





This high quality spring enables to adjust spring rate in accordance with its length.

POLE POSITION OIL

The high quality oil combining fluorine.



RO-101  Chassis frame rails	RO-102  Front guard and under guard	RO-103  Mechanical plate	RO-104  Gear case	RO-105  Front bumper
RO-106  Front suspension arms	RO-107  Axle for front suspension arms	RO-108  Gear case and motor mount	RO-109  Rear plate and battery holder	RO-110  Roll bars, bumper and guards
RO-111  Rear shock set	RO-112  Front shock set	RO-113  King-pin	RO-114  Middle gear set	RO-115  Threaded rods and ball joints
RO-116  Speed controller set	RO-117  Front stabilizer set	RO-118  Rear stabilizer set	RO-119  Screw set	RO-6  Plastic parts set
RO-8  Front tire	RO-8A  Front wheel	RO-10  Rear tire	RO-10A  Rear wheel	RO-17  Steering arm set
RO-18  12T. motor pinion gear	RO-19  13T. motor pinion gear	RO-20  14T. motor pinion gear	RO-24  Differential gear set	RO-26  Speed plate and wiper
RO-26A  Resistor	RO-27  Rear wheel axle	RO-27A  Half shaft	RO-28  Rear trailing arm set	RO-29  Rear arm mount and link axle
RO-33  Driver	RO-35  Antenna	RO-39  E-clip set	RO-121  Buffalo body shell	RO-120  Bobcat body shell

 <p>MAGNUM 360L motor</p>	<p>61AL</p>  <p>Servo bracket</p>	<p>RB-28</p>  <p>Double-sided adhesive tape</p>	<p>RB-44</p>  <p>3mm lock nuts</p>	<p>RB-46</p>  <p>4mm lock nuts</p>
<p>RX-18EX</p>  <p>Servo saver</p>	<p>13EXL</p>  <p>Nylon band (large)</p>	<p>CK-13</p>  <p>Nylon-band (small)</p>	<p>RX-28</p>  <p>Hexagon wrench set</p>	<p>RX-38</p>  <p>4 X 4mm set screw</p>
<p>RX-44</p>  <p>Body catch pins</p>	<p>RS-39</p>  <p>Set screw 3X3mm 3X5mm</p>	<p>RS-73</p>  <p>Shock oil</p>	 <p>7.2V/1200mAh NiCad pack</p>	 <p>4P Connector</p>
 <p>Rear tire spikes (40pcs)</p>	 <p>Washers for adjusting of differential gear and screws</p>	 <p>Inequal space spring set</p>	<p>Decals</p>	

