

CIRCUIT 2000 SERIES

RADIO CONTROLLED OFF-ROAD RACING BUGGY KIT

IMPACTA BAJA

MINT LAS VEGAS

MID ENGINE PLACEMENT ASSURES TOP HANDLING CHARACTERISTICS AND OPTIMUM BALANCE FOR GREATER ROAD HANDLING AND REAR WHEEL TRACTION.

FRONT OIL FILLED/COIL SPRING AND REAR LONG TRAVEL SHOCKS ARE STANDARD EQUIPMENT FOR EFFECTIVE TERRAIN CONTROL

.20 ENGINE POWER & 2- CHANNEL RADIO NOT INCLUDED

1:8 SCALE



KIT NO.3048
IMPACTA BAJA



KIT NO.3049
MINT

INSTRUCTION MANUAL

KYOSHO
THE FINEST RADIO CONTROL MODELS

THINGS YOU WILL NEED BESIDES THIS KIT

[2 channel radio system]

A two channel, 2 servo radio control unit is required for running this car. This type of radio system can also be used for other models requiring only two channels of control. You will also need to supply your radio with the proper number of batteries (Usually 7 or 8 in the transmitter and 4 for the receiver.) A system with servo reversing (or simply using a reverse servo on the steering control) will be necessary.



Batteries

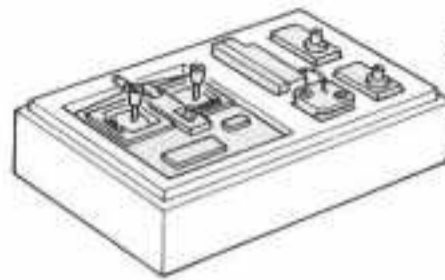

2 Channel Radio System

[Engine]

The Irvine 20 or 25 car engines, or the OS Max 21 FSR-B side exhaust car engine will mount with little or no modifications. The OS 21VF-B, OS 21VF-C, PICCO 3.5, Enya 21CX, 21CXS, 19X HP .25VT/car and others will require either additional parts or more than slight modifications. If you are planning to use an aircraft type engine you MUST supply it with a heat sink device to help cool the engine. Without a heatsink, the engine will overheat and be destroyed.

If you plan to use an OS MAX rear exhaust engine such as the 21VF-B or 21VF-C you will need the two parts listed below (See page 23.)



Your engine should have a heat sink head

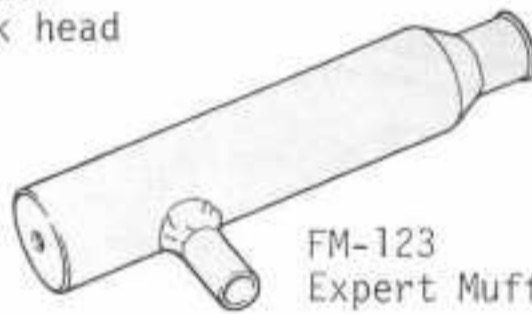

FM-123 Expert Muffler



FM-130 Manifold

These two items are required for OS Max rear exhaust engines.

[Items Required for Running]



Glow Fuel



Fuel Bulb

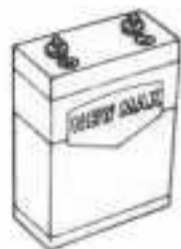

1.5V Battery for Glow Plug



Glow Plug Cord



Starter w/"DONUT"

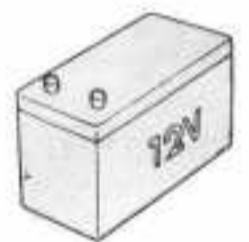

12V Battery (FOR STARTER)

TOOLS REQUIRED

The following tools are included in kit. The following tools are required for assembly.

1.5mm Allen Wrench

2mm Allen Wrench

2.5mm Allen Wrench



Scissors

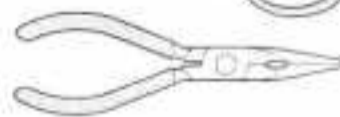

Needle Nose Pliers



Awl



Pliers



Cross Wrench



+ Driver(L,S)



5.5mm & 7mm HEX Driver



Instant Cement



Rubber Cement



Brush



Paint



Masking Tape

HOW TO CHECK YOUR RADIO SYSTEM

Follow steps 1-8 in order.

1. Install the batteries into both the transmitter and receiver. If your radio is a rechargeable system, charge it as outlined in the manual that came with your set.
2. Unravel the receiver antenna and plug the servo and battery connectors into the receiver.
3. Extend the transmitter antenna.
4. Turn ON the power switch at the transmitter.
5. Turn ON the power switch for the receiver.
6. Set the small trim levers to the center position and make sure that both main control sticks are also centered.
7. Move both main control sticks slowly through their full travel. The servo horns should move in proportion to the movement of your sticks.
8. When the trim levers and sticks are at their neutral positions, the servo horns should be centered. You may now turn off the transmitter, then the receiver and unplug the servos and battery from the receiver.

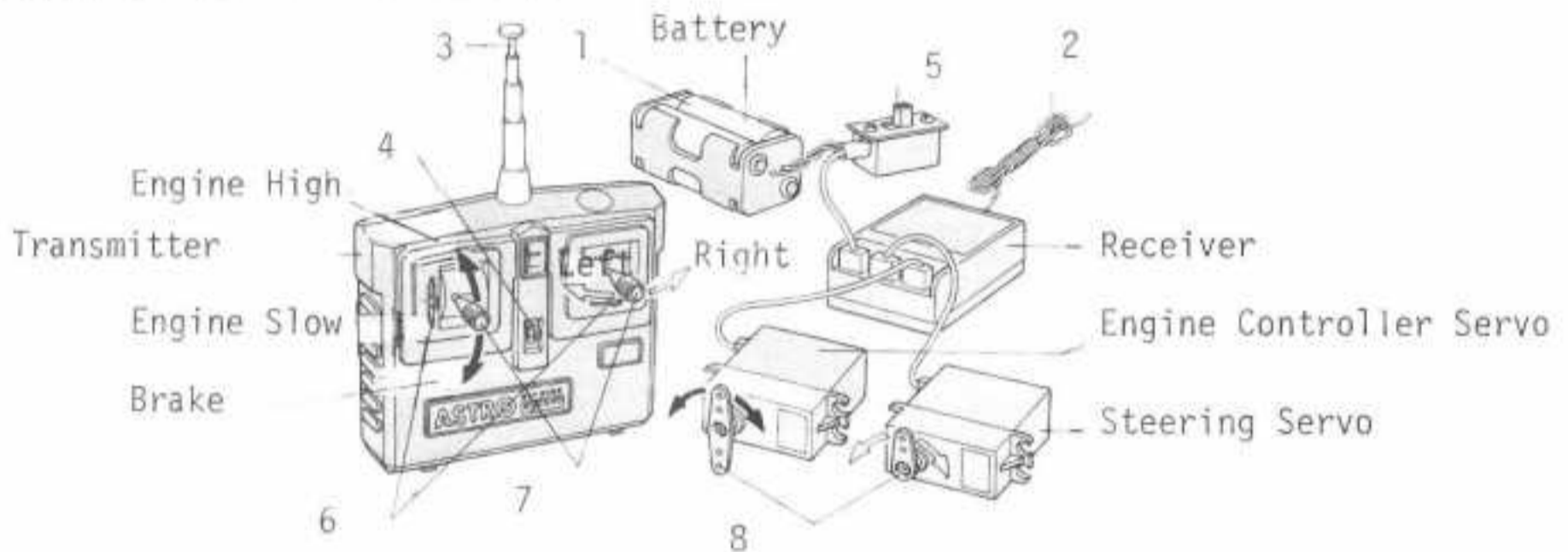

*IT IS IMPORTANT TO ALWAYS SWITCH THE TRANSMITTER ON FIRST ... THEN THE RECEIVER. WHEN TURNING OFF THE SYSTEM TURN OFF THE RECEIVER FIRST AND THEN THE TRANSMITTERS.

A 2-channel radio control system is composed of a transmitter, a receiver, two servos, and a battery holder (for the receiver.)

*Transmitter.....This is the part of the system that you hold in your hands to control the model. Information is sent to the receiver and servos via radio waves.

*Receiver.....Receives the radio signals from the transmitter and sends them to the appropriate servo.

*Servos.....Can be thought of as the "muscle" of the system. They actually move the controls of the model. The receiver tells them which direction to move and how much.

*Antenna.....The transmitter antenna broadcasts the radio signal. The receiver antenna (which is no more than a small wire tuned to a precise length) picks up the signals so that the receiver can decode them.

*Trim Levers.....Adjust the neutral position of the servos from the transmitter. Trim levers provide fine tuning of the steering and speed control.

*Battery Meter...Allows you to see the condition of your transmitter batteries.

*Servo Horn.....A small arm or wheel on a servo that transfers the movement of the servo.

IMPORTANT! BEFORE YOU BEGIN

A WORD OF WARNING is necessary, especially if this happens to be your first gas-powered vehicle. Gas-powered cars are subjected to unbelievable stress and strain due to high engine RPM, rough terrain and the racing/high performance usage that they receive. As a result, they need continual preventative maintenance to keep them in operating condition.

This is an extremely sophisticated model with a large number of moving parts. Assembly of the model by a completely inexperienced builder could turn out to be a very frustrating experience. Before you begin assembly, take a look through the box and these instructions carefully to decide whether or not you are ready for this challenge! If you do not feel that this type of model is for you, it may be returned to the dealer as long as it is NEW and UNUSED. UNDER NO CIRCUMSTANCES CAN YOUR DEALER ACCEPT A KIT FOR RETURN IF ASSEMBLY HAS ALREADY BEGUN! If this is not what you bargained for, then go no further and return this kit to the dealer immediately. BUT, if a little maintenance doesn't bother you and the thrill of high performance driving is for you, then don't hesitate another minute! Read through this entire manual thoroughly to familiarize yourself with the parts and methods of construction used before actually starting to build.







*All nuts and bolts used throughout this kit are metric sized.

Therefore, some of the notations may not be familiar to you. An M3 nut is a 3 millimeter (3mm) nut. An M3 x 12 screw is 12mm long and 3mm in diameter. At various points throughout the manual these parts are labeled and pictured in their actual size. For your reference, 1mm equals approximately .039 inches.

*In addition to the damper oil (red liquid) you will also find a small tube of "screw cement". This bluish-green cement should be used on all nuts and bolts in the car including those parts which are ALREADY ASSEMBLED. If you do not use the screw cement, all the nuts and bolts of the car WILL eventually fall out. This particular formula is safe for both nylon and metal parts. Use this type of cement only on the nuts and bolts. When it calls for cement in the manual, use an "instant" type of glue such as Jet, CA or Hot Stuff.

1 ASSEMBLY OF MAIN CHASSIS

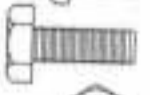
[Small Parts Used]

-  M3 x 10 Screw ... 2
-  M3 x 16 Screw ... 2
-  M3 x 20 Flanged Screw ... 2
-  M4 x 6 Screw 1
-  M4 x 10 Allen Wrench 1
-  M3 Nut 2
-  M3 Nylon Nut 1

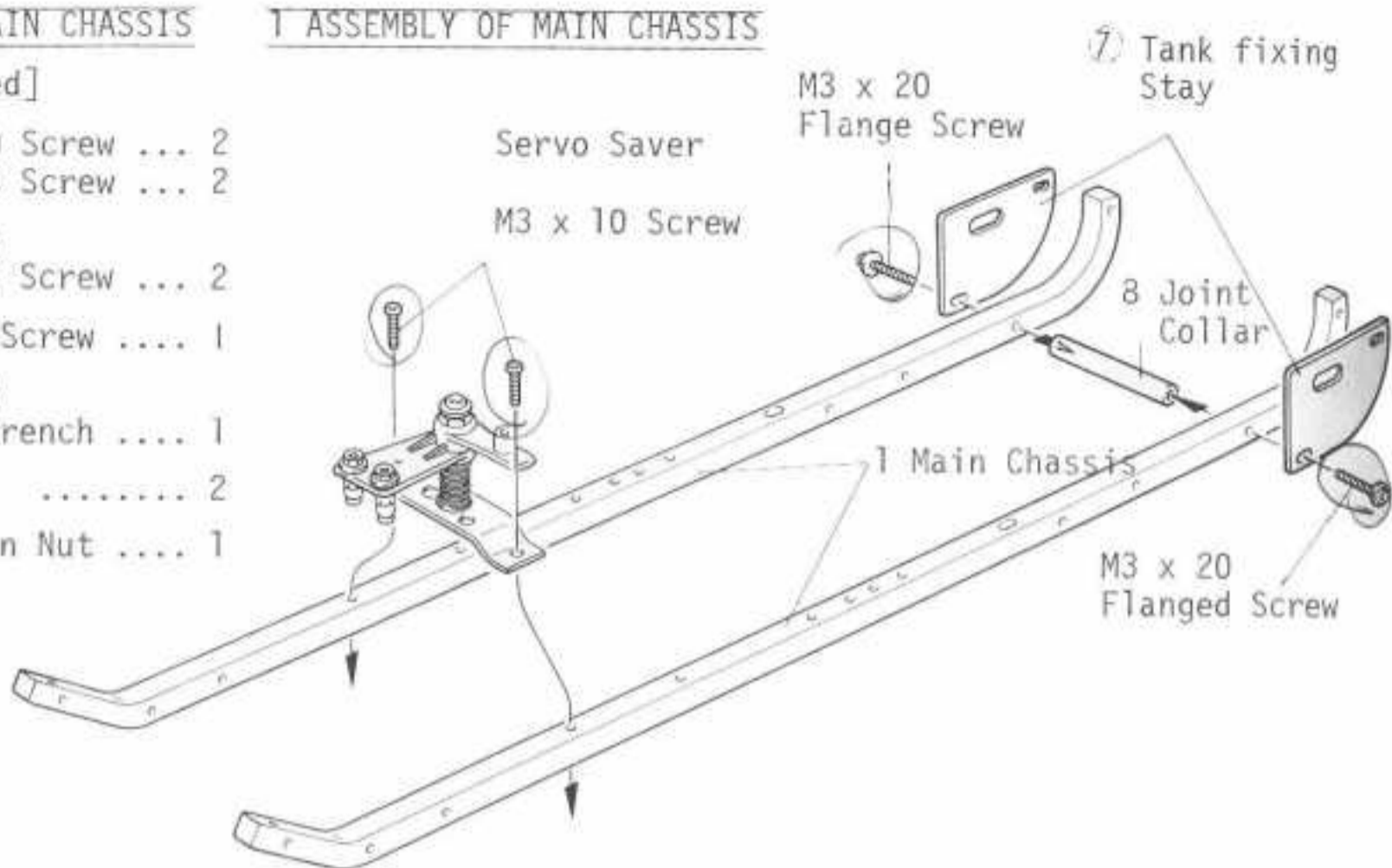

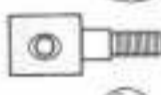
-  M3 Flange Screw.. 2
-  4 ϕ Washer 1
-  5 Ball Collar ... 2
-  6 Steering Linkage.1
-  15 Ball2

[Installation of Servo Saver]

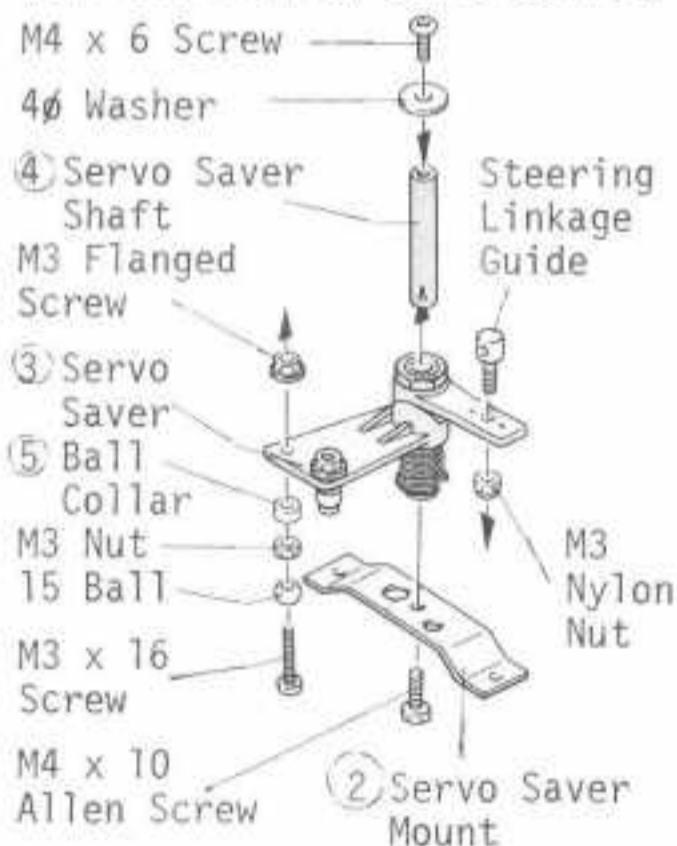

2 ASSEMBLY OF KNUCKLE ARM

*Assemble 2 sets of these.

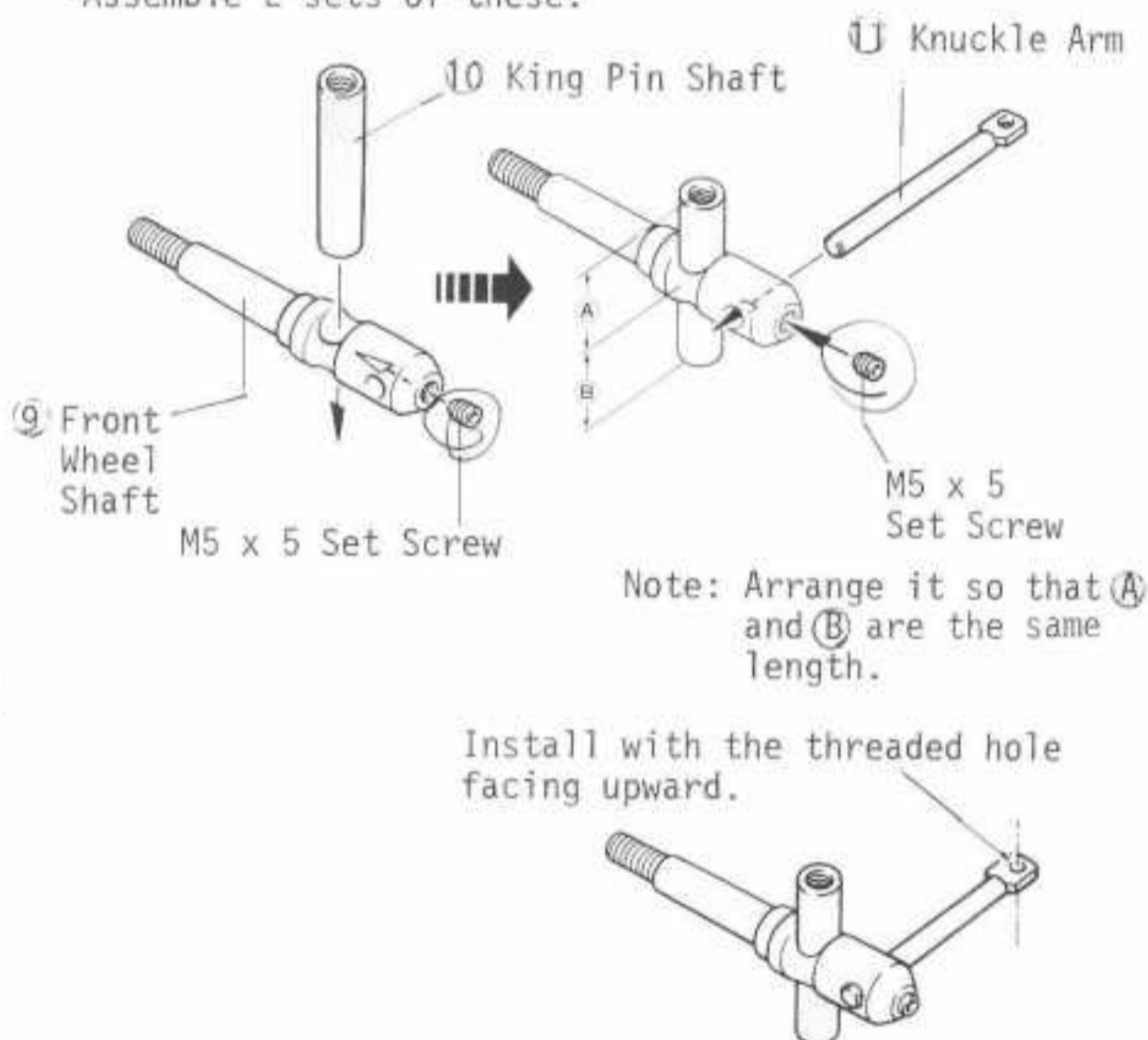

2 ASSEMBLY OF KNUCKLE ARM



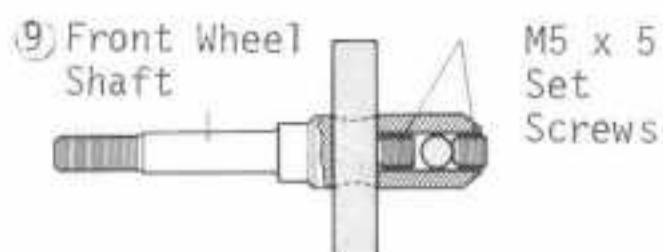

[Small Parts Used]

-  M5 x 5 Set Screw ... 4



3 INSTALLATION OF KNUCKLE ARM

[Small Parts Used]

-  M3 x 12 Screw 2
-  M3 Nut 4
-  4φ Washer 4
-  14 King Pin 4
-  15 Ball 2

3 INSTALLATION OF KNUCKLE ARM

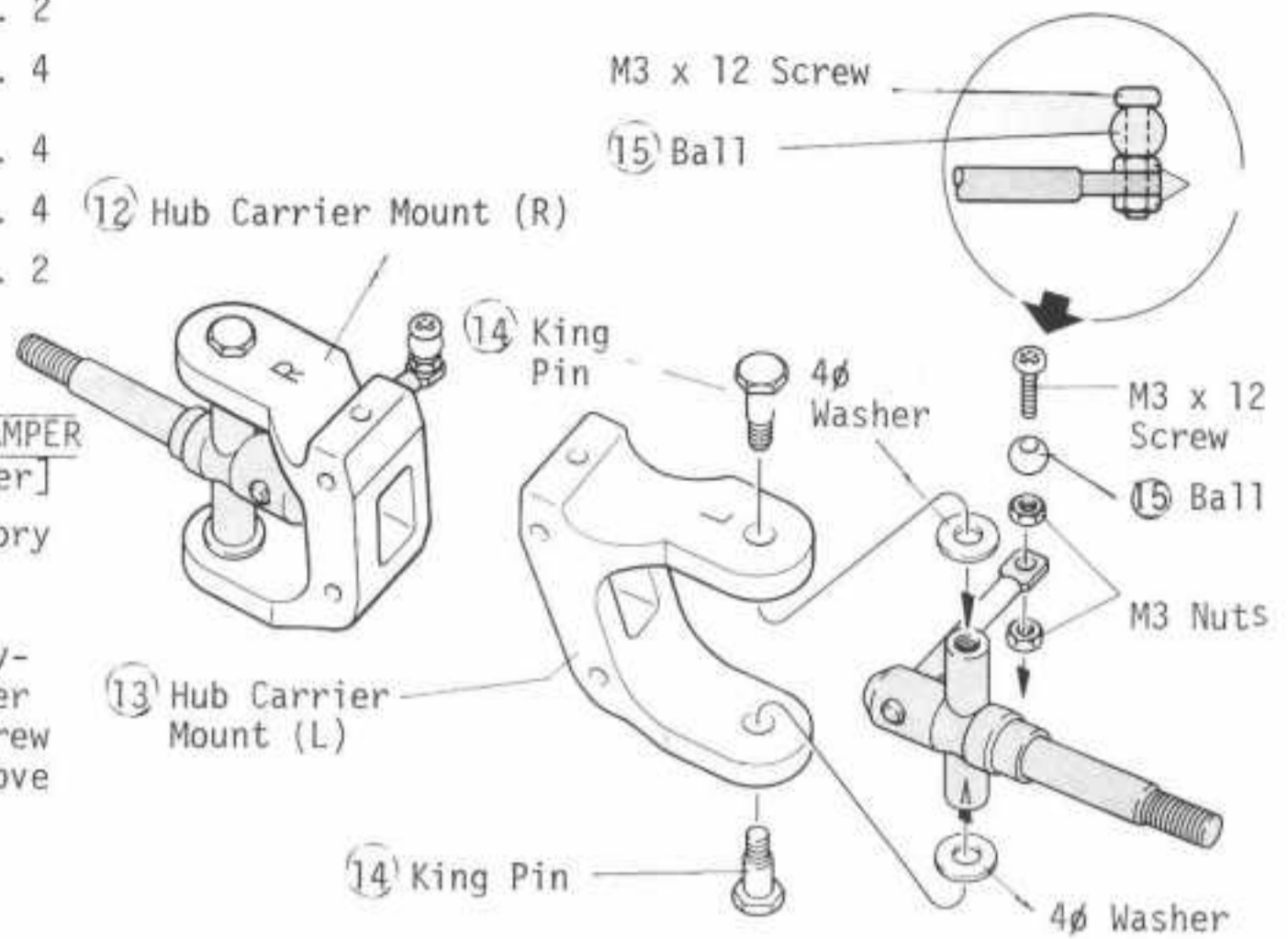

4 POURING OIL INTO FRONT DAMPER

[Disassembly of Front Damper]

The front dampers are factory assembled, but not filled with oil. Disassemble the front shocks by first removing the coil spring retainer and then the springs. Unscrew the damper stopper and remove it.

Note: the rear dampers are already oil-filled.

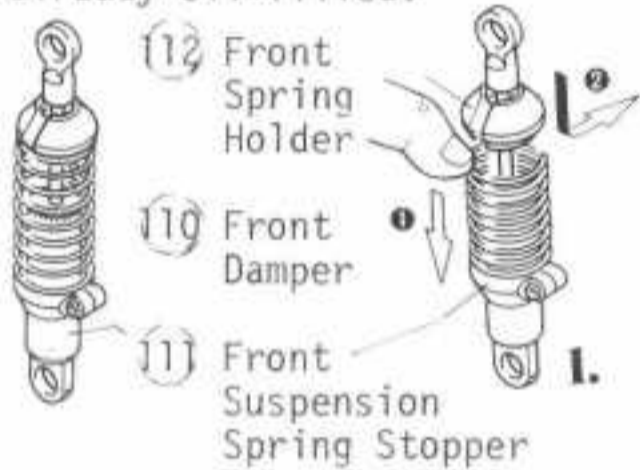

(Compress the spring as shown, then slide the spring holder sideways to remove it)

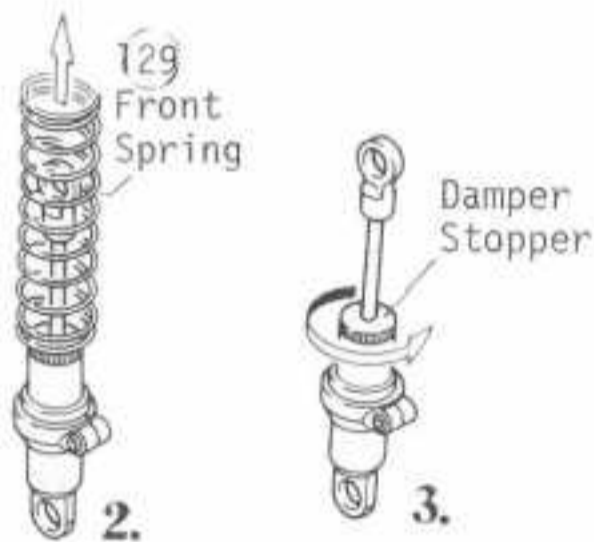

Detach the spring. Remove the damper stopper and pull out the piston.

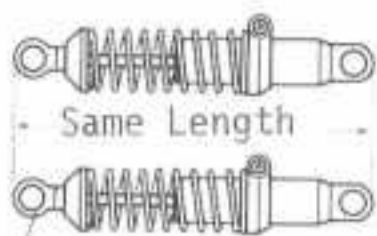

4 POURING OIL INTO FRONT DAMPER

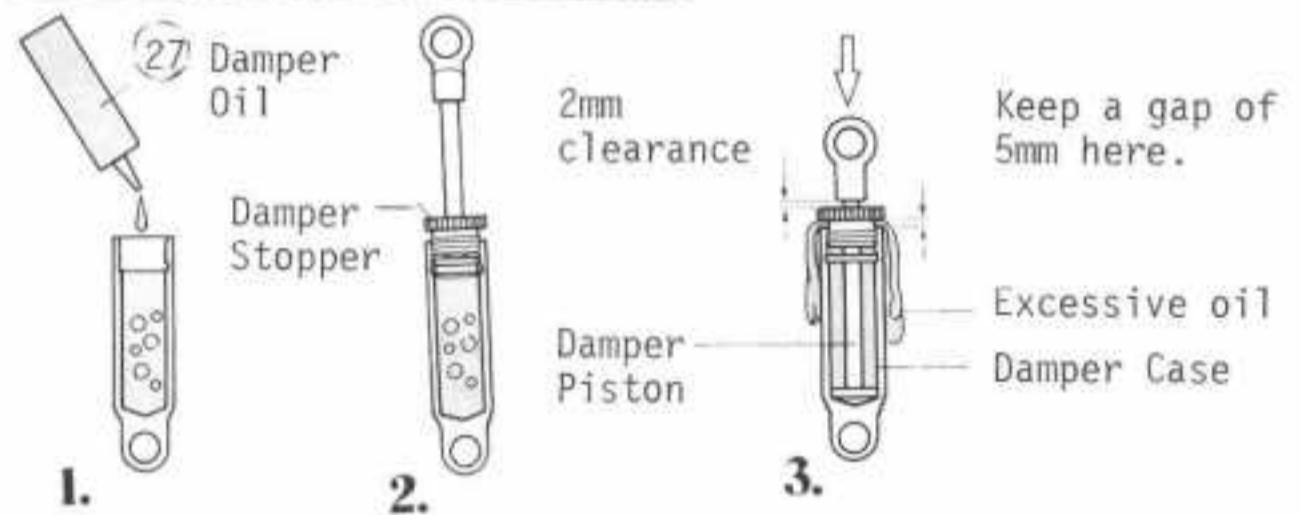

1. Pour the oil (red liquid) into the damper up to the point shown above.
2. Screw in the damper stopper.
3. Keep a gap of about 5mm between the damper stopper and the damper case and push the piston all the way down to squeeze out any excess.
4. Screw in the damper tightly by holding it with pliers as shown above. You may then install a ball into each front shock ball end.



5 ASSEMBLY OF FRONT SUSPENSION

[Small Parts Used]

-  M3 x 14 Self Tapping Screw..... 2
-  M3 x 3 Set Screw.... 2
-  M3 x 5 Set Screw.... 4
-  M4 x 6 Set Screw.... 4
-  24 Damper Bushing... 2
-  25 3ø Stopper..... 2
-  45 Damper Collar.... 2

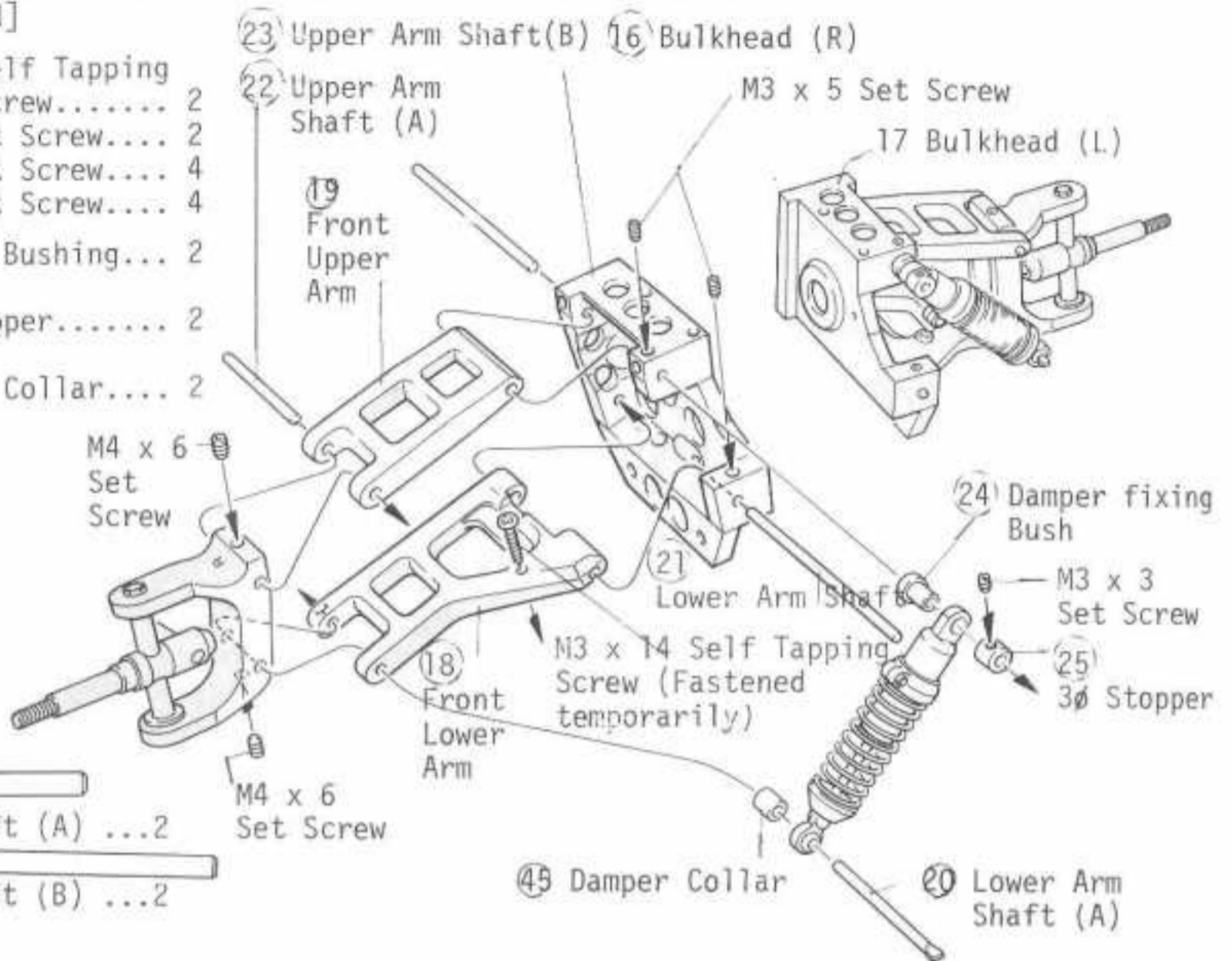
5 ASSEMBLY OF FRONT SUSPENSION

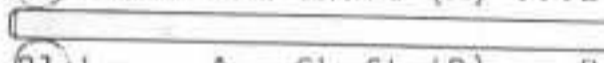

-  20 Lower Arm Shaft (A) ...2
-  21 Lower Arm Shaft (B) ...2
-  22 Upper Arm Shaft (A) ...2
-  23 Upper Arm Shaft (B) ...2

6 INSTALLATION OF FRONT SUSPENSION

[Small Parts Used]

-  M3 x 20 Screw ..5
-  M4 x 10 Self Tapping Screw4
-  M3 Flanged Screw4

6 INSTALLATION OF FRONT SUSPENSION

The wider frame part should face forward.

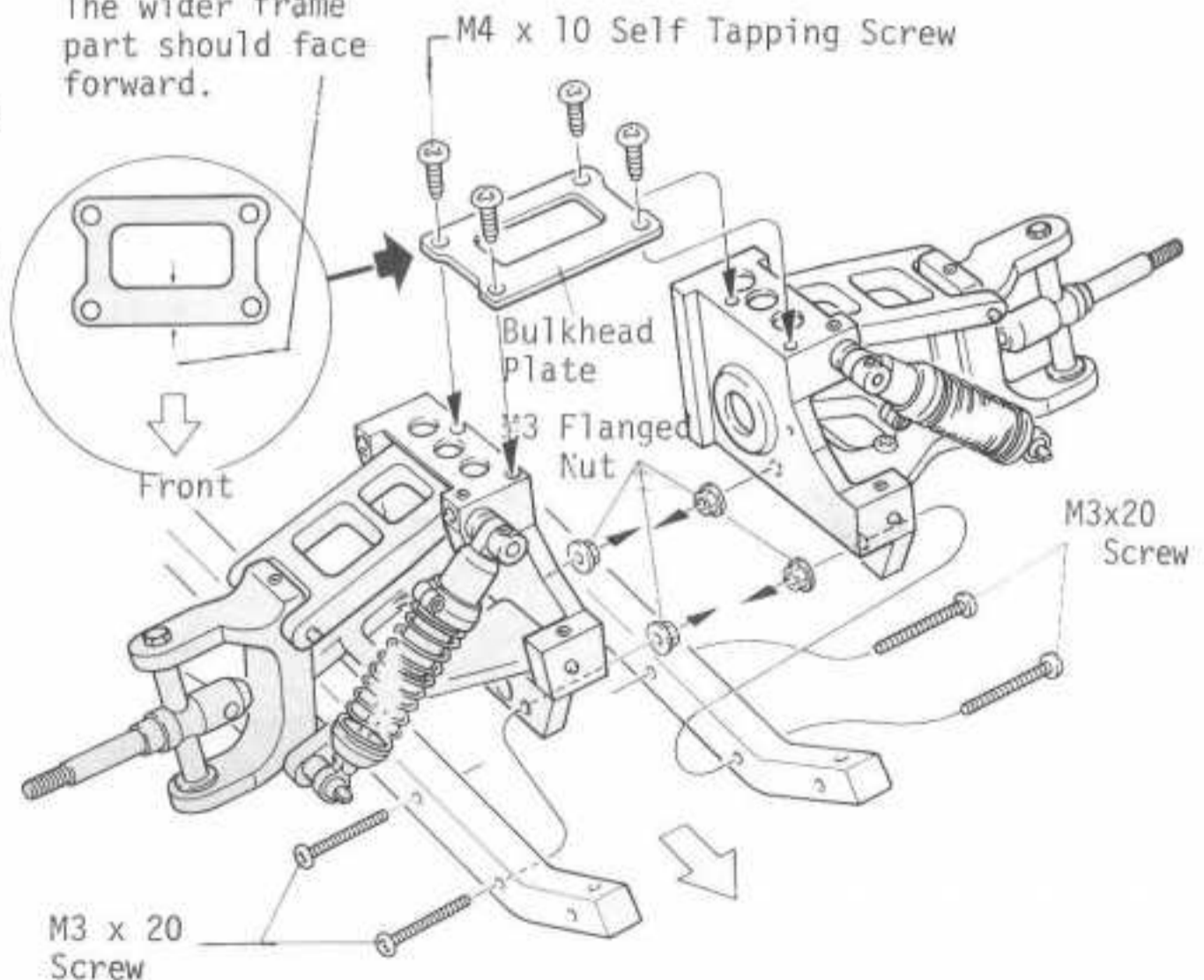

7 INSTALLATION OF TIE ROD

7 INSTALLATION OF TIE ROD

[Small Parts Used]

- 28 Ball End (S)...2
- 29 Ball End (L).....2

Screw the ball ends onto the control rod as shown in the illustration below. Over all measurement of complete assembly should be 97mm (about 3 13/16 inches).

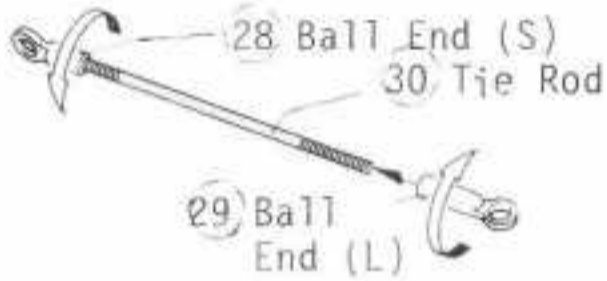
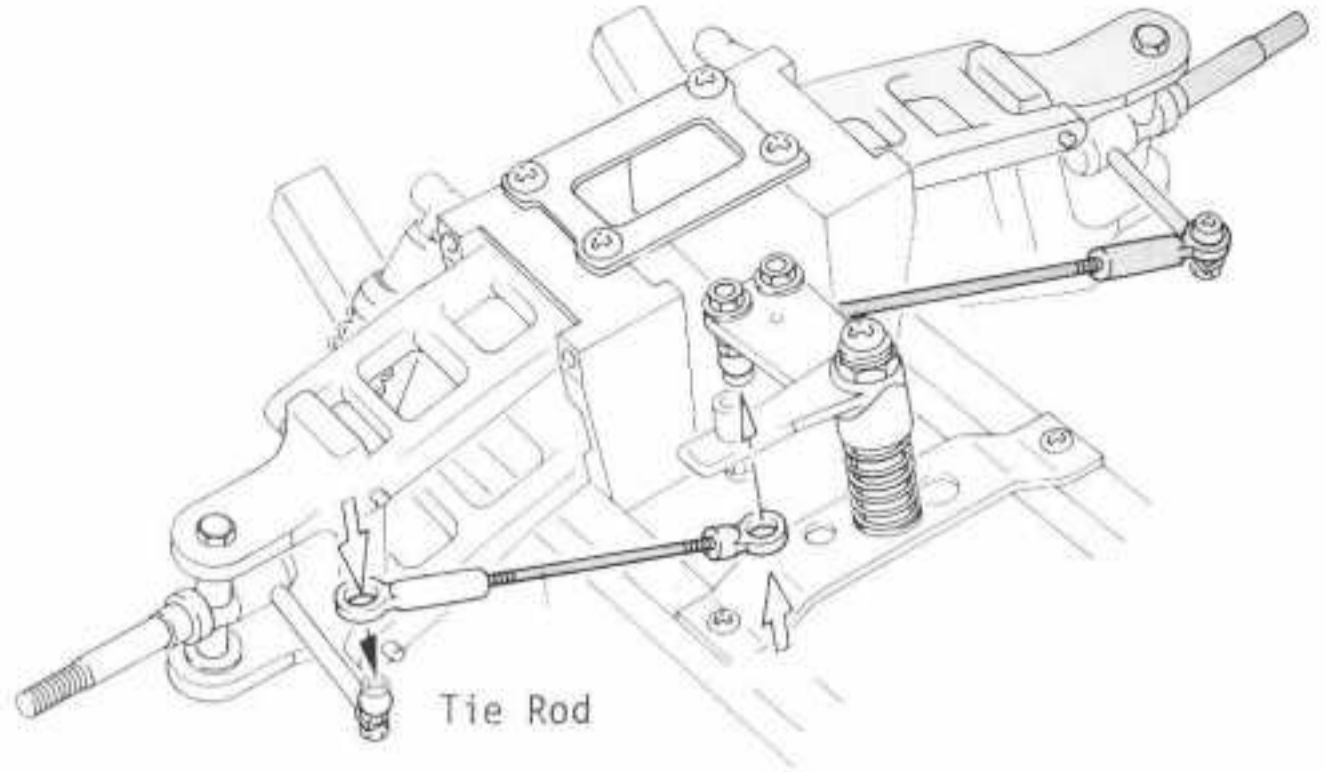

8 ASSEMBLY OF REAR AXLE

8 ASSEMBLY OF REAR AXLE

[Small Parts Used]

31 Rear Axle Bearing

- M3 x 10 Self Tapping Screw2
- M3 x 12 Self Tapping Screw1
- M4 x 10 Self Tapping Screw..... 2
- M4 x 18 Self Tapping Screw2

- M3 x 10 Self Tapping Screw for preventing the Disk from vibrating.
- 4 x 10 Self Tapping Screw

M4 x 18 Self Tapping Screw

Screw the bolt into the bulkhead leaving 6mm of space between the head of the screw and the bulkhead.

45 Damper Collar...1

[Assembly of Ball Bearing]
Follow exploded view below; simply snap the balls into the retainer and slip the ring over the assembly.

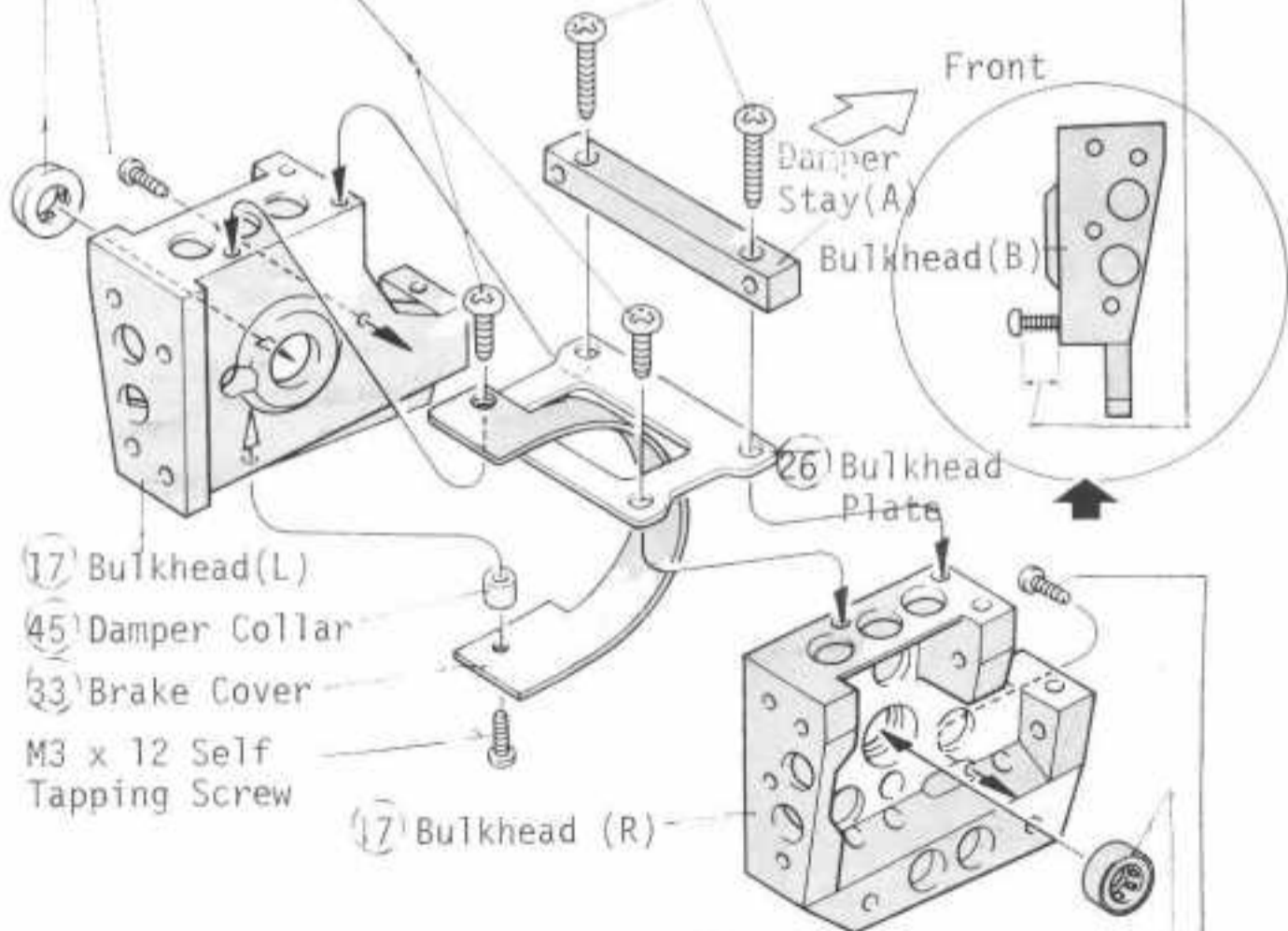

- 31 Rear Axle Bearing
- Ring
- 2mm Balls (8 pieces)
- Retainer

[Fixing Direction]
32 Damper Stay (A)
26 Bulkhead Plate

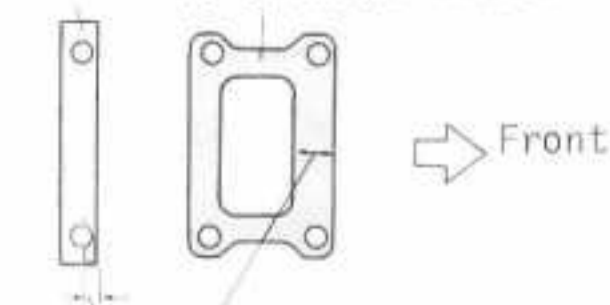

The narrower edge should be set forward.

- 31 Rear Axle Bearing
- M3 x 10 Self Tapping Screw (Pebble Deflector)

9 INSTALLATION OF CENTER SHAFT 9 INSTALLATION OF CENTER SHAFT

[Small Parts Used]

 M5 x 6 Set Screw... 1

10 INSTALLATION OF BRAKE CALIPER

-  M3 x 10 Self Tapping Screw2
-  M4 x 16 Self Tapping Screw2
-  M3 x 14 Screw2
-  M3 x 4 Set Screw...1
-  M3 Nut (Thinner Nut)2

 36 Brake Arm ...2

[Assembly of Brake Caliper]

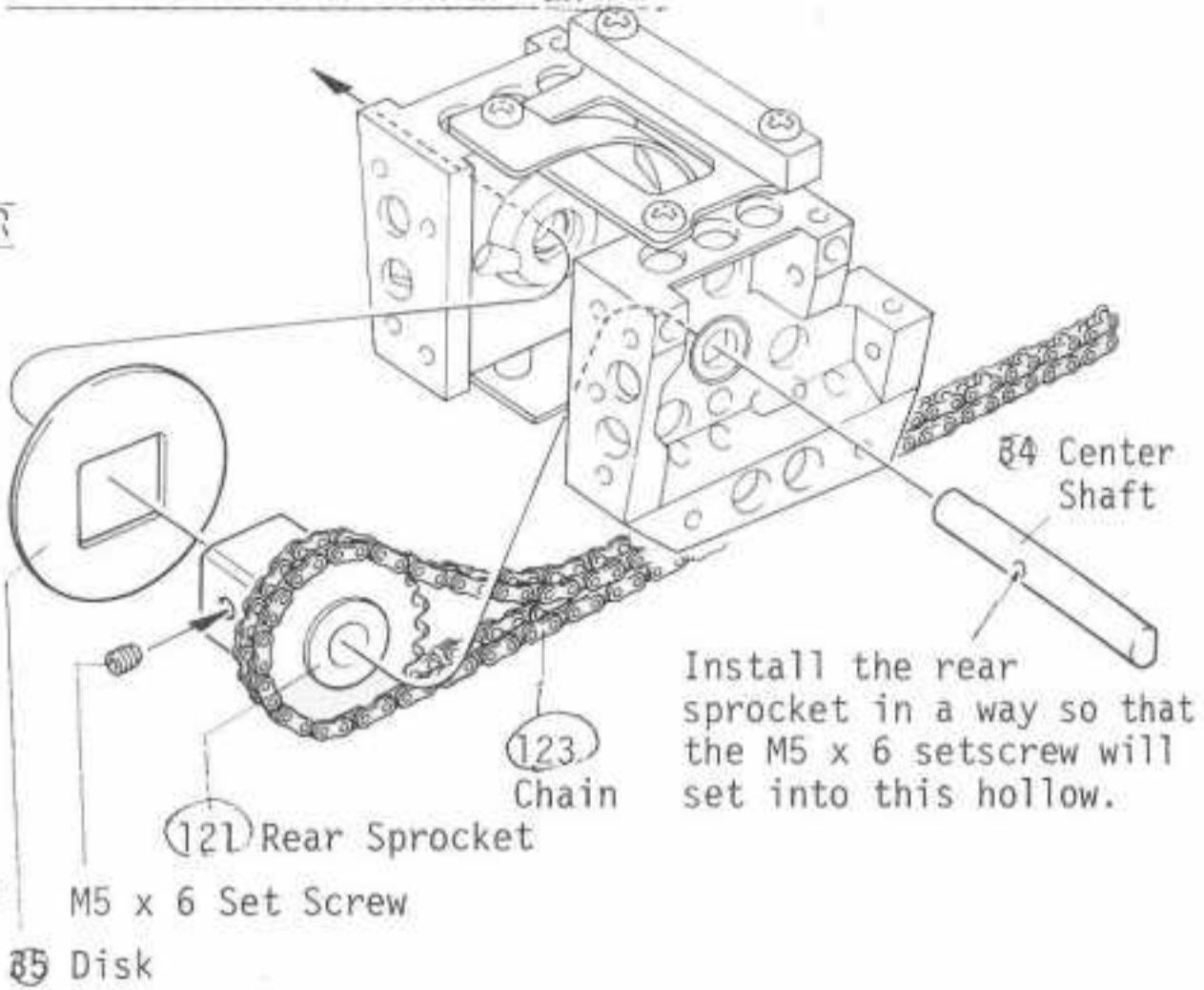
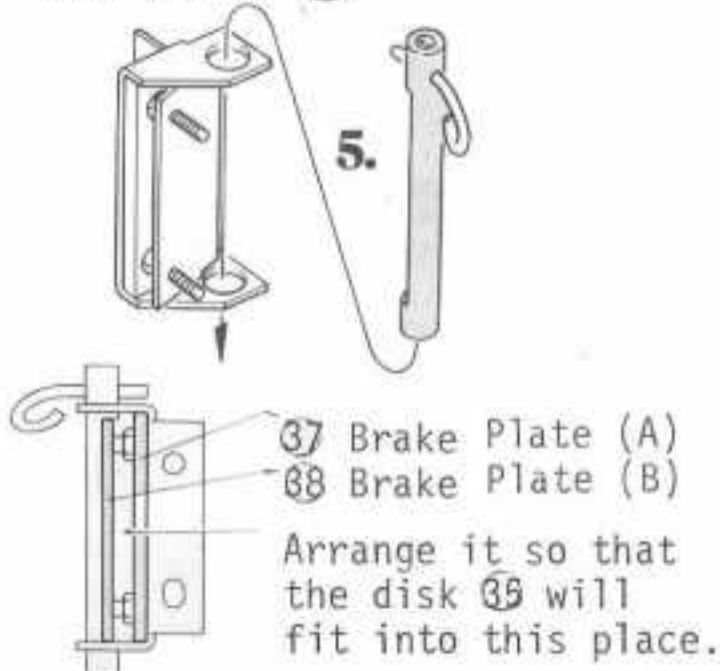
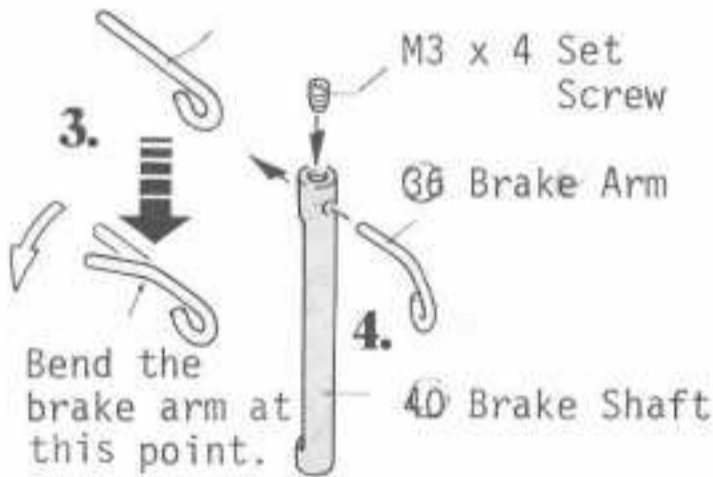
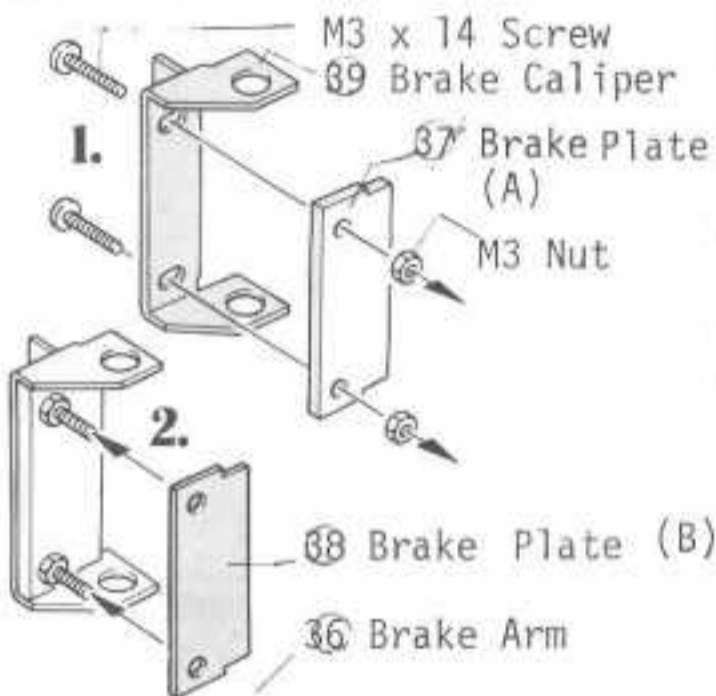

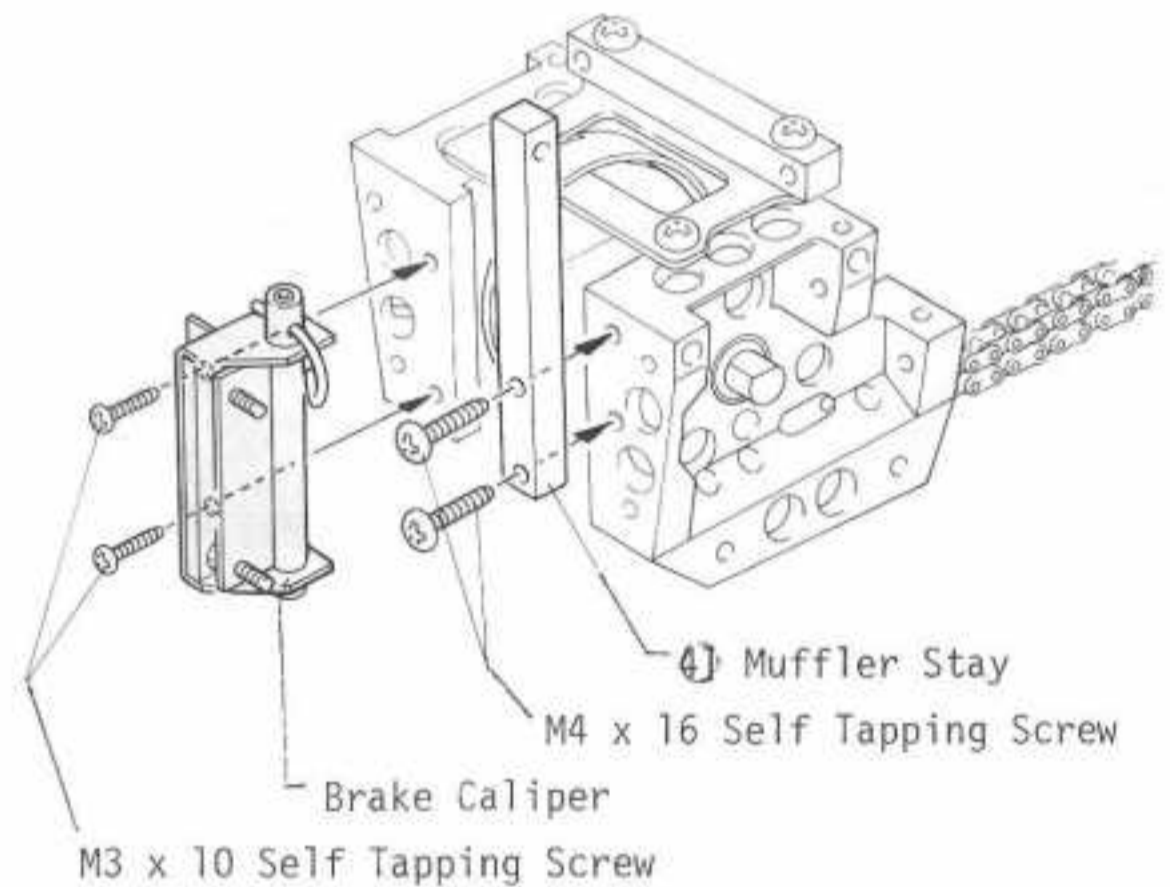

Install the rear sprocket in a way so that the M5 x 6 setscrew will set into this hollow.

10 INSTALLATION OF BRAKE CALIPER



11 FIXING OF REAR AXLE

[Small Parts Used]

-  M3 x 20 Screw ...4
-  M3 Flanged Nut ...4
-  3mm Washer1

Put a 3 mm washer only onto this bolt.

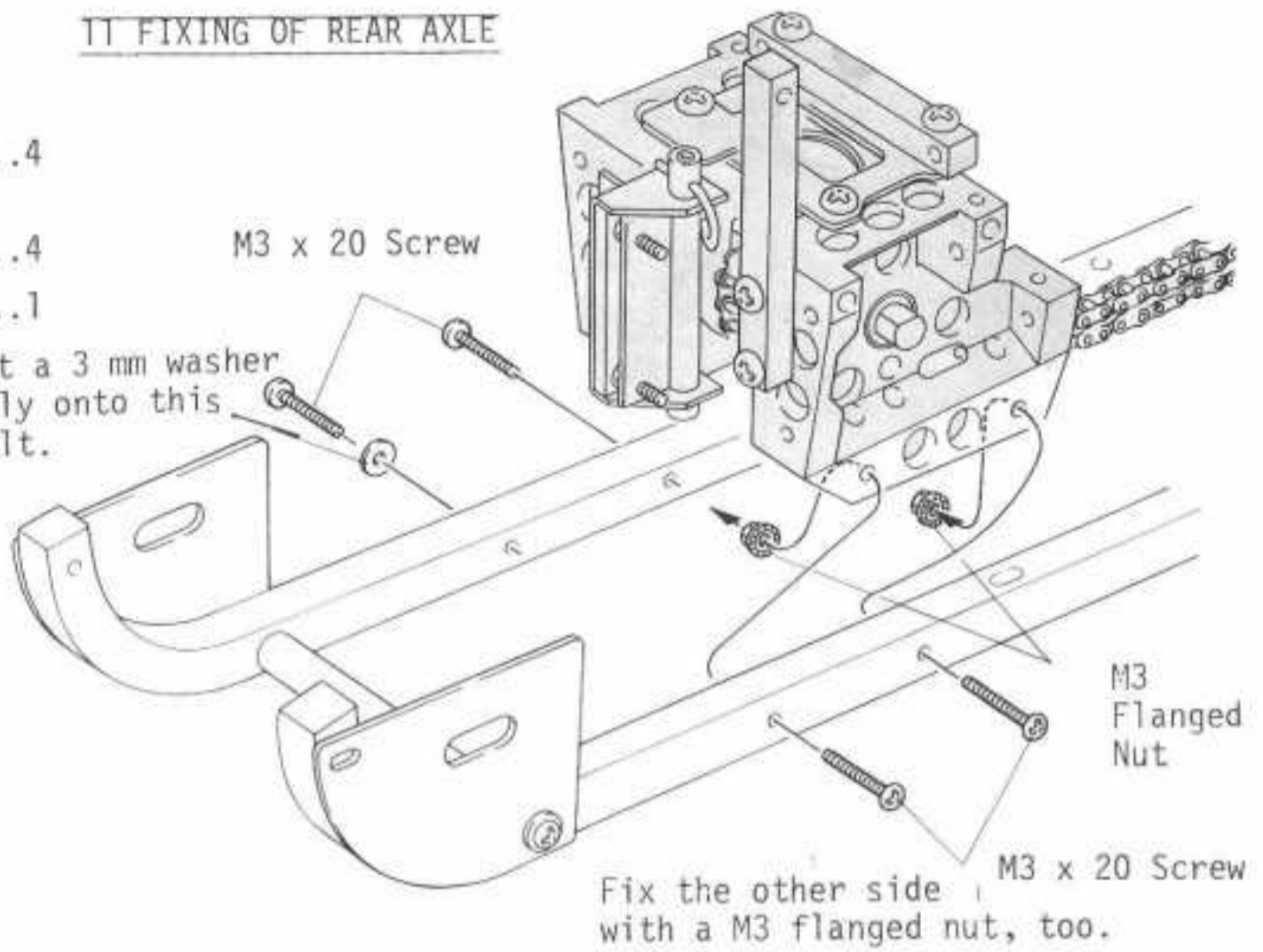

12 INSTALLATION OF JOINTS

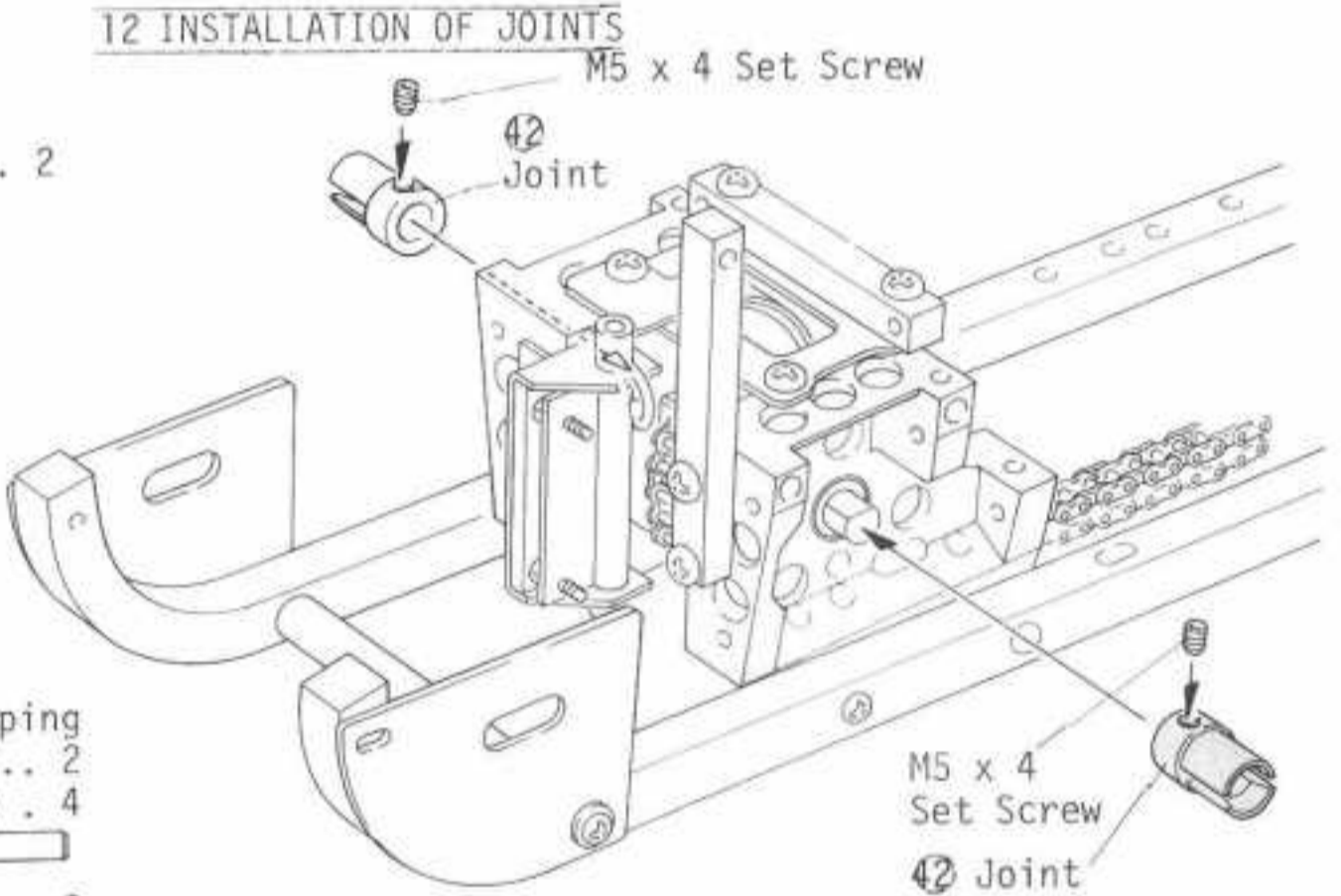

[Small Parts Used]

-  M5 x 4 Set Screw ... 2



13 INSTALLATION OF REAR SUSPENSION ARM

[Small Parts Used]

-  M3 x 14 Self Tapping Screw 2
-  M3 x 5 Set Screw . 4

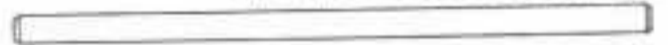
-  Lower Arm Shaft (B) 2

-  Rear Upper Shaft 2

[Installation of Height Adjustment Screw]

M3 x 14 Self Tapping Screw (Fastened temporarily)

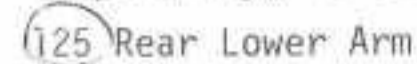
-  Rear Lower Arm

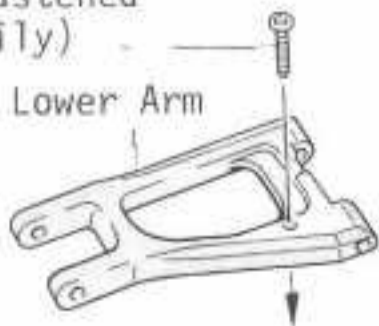





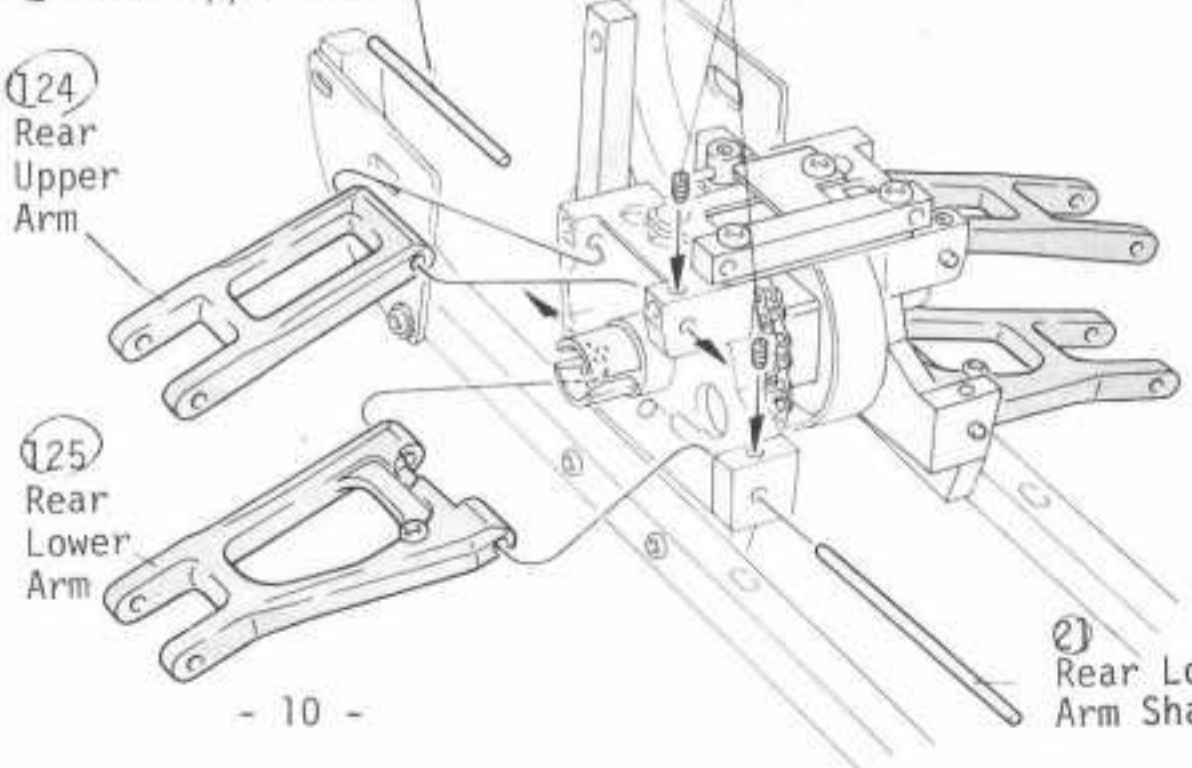

13 INSTALLATION OF REAR SUSPENSION ARM

-  Rear Upper Shaft



T4 ASSEMBLY OF REAR DAMPER

[Small Parts Used]

-  M3 x 14 Screw 2
-  M3 x 24 Flanged Screw 2
-  M3 Nut 2
-  M3 Flanged Nut 2
-  24 Damper Bushing 2
-  45 Damper Collar 2

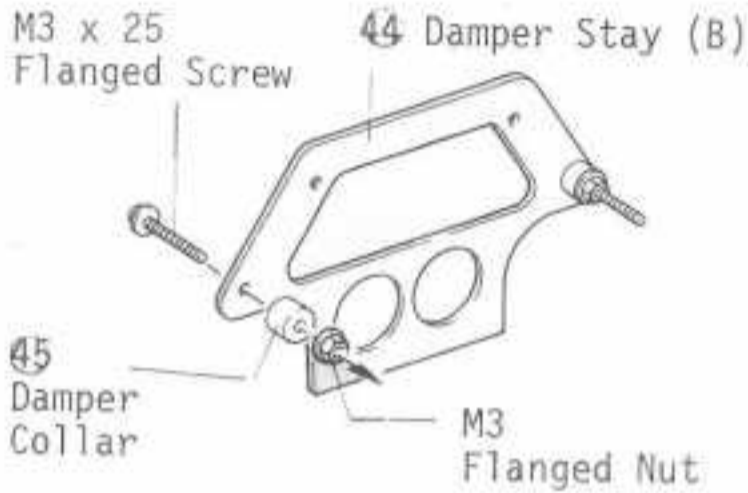

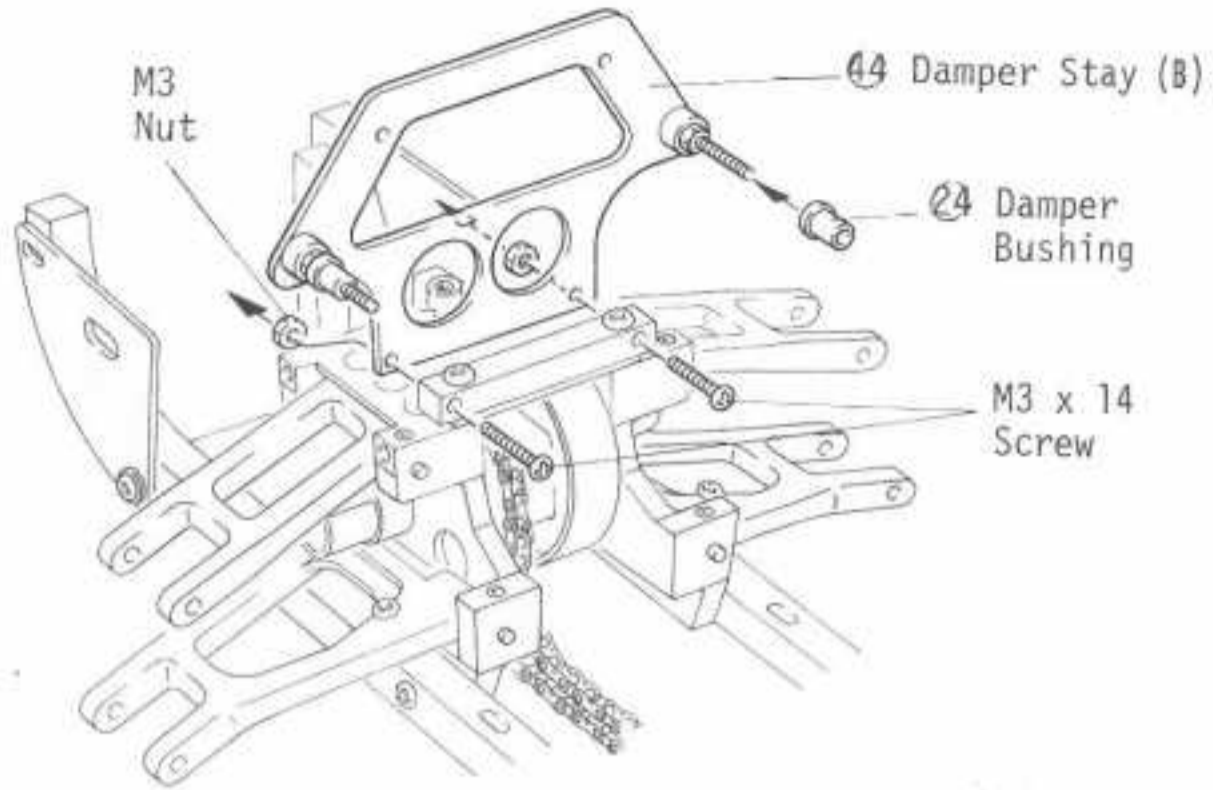

T4 ASSEMBLY OF REAR DAMPER



T5 INSTALLATION OF REAR DAMPER

[Small Parts Used]

-  M4 x 6 Set Screw..4
-  M3 Nylon Nut2
-  15 Ball2

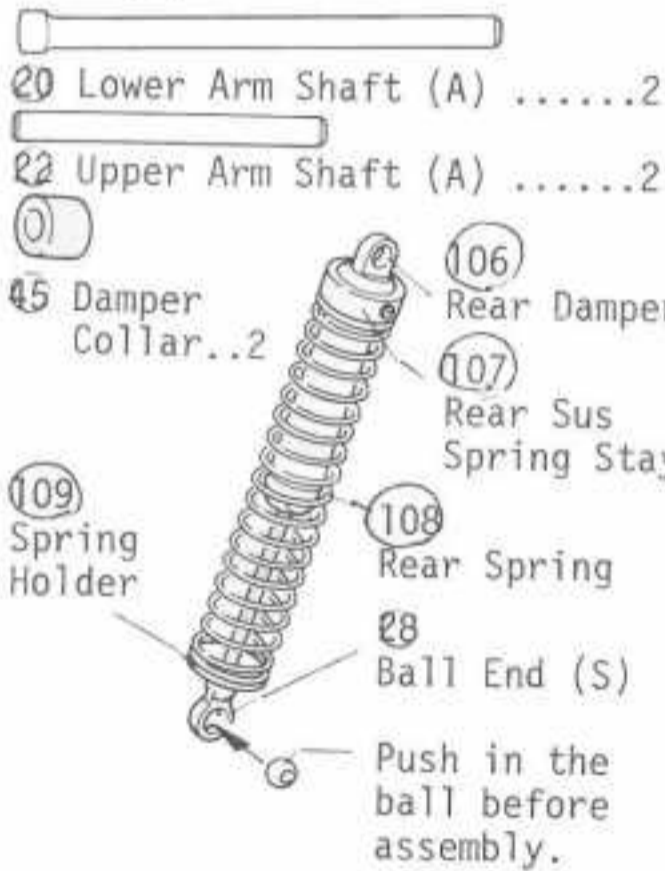

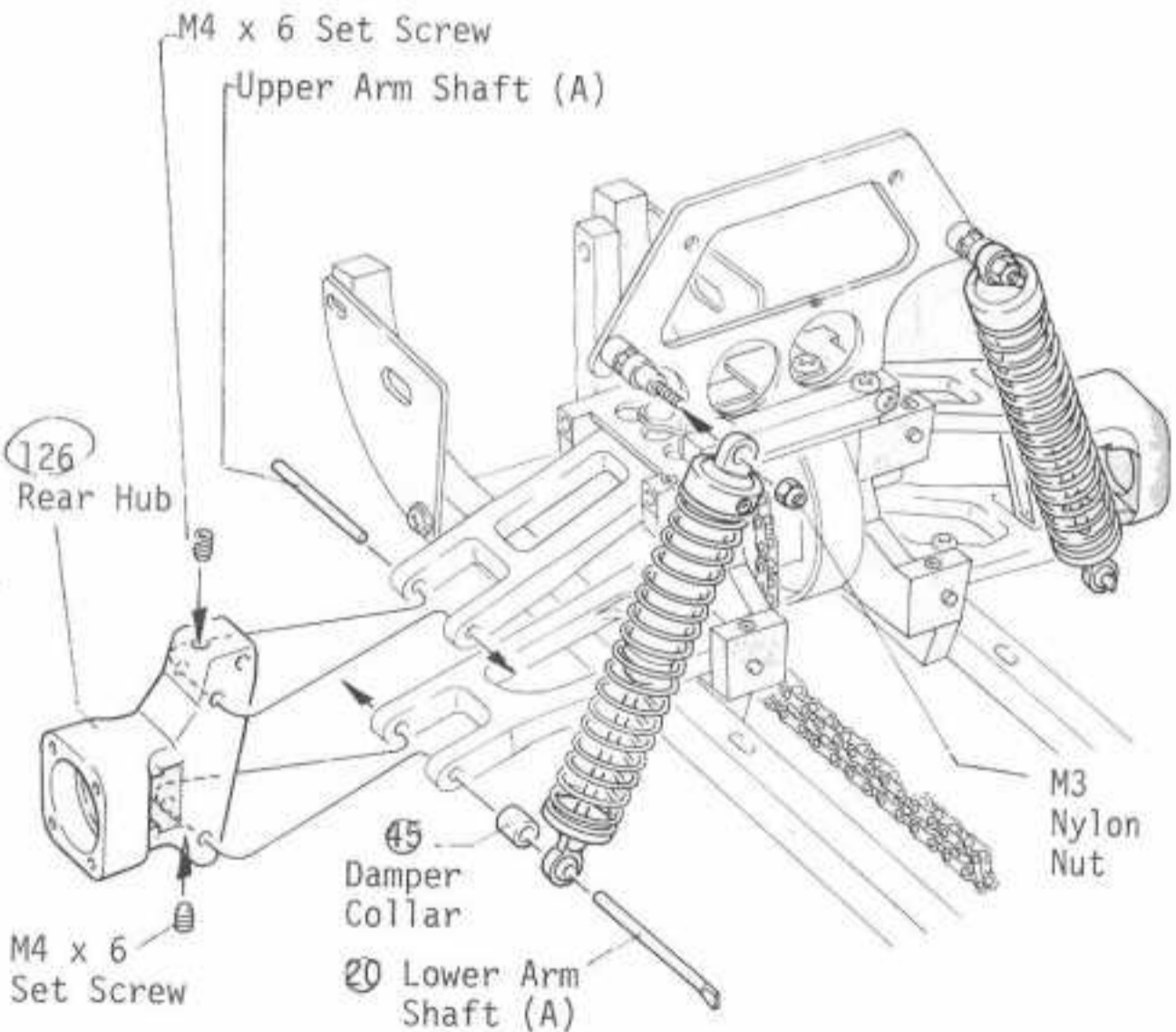

T5 INSTALLATION OF REAR DAMPER

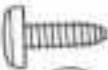

16 FIXING OF SWING SHAFT

[Small Parts Used]

-  M3 x 8 Self Tapping Screw 2
-  3ø Washer 8

Insert the rear axle (46) into the rear ball bearing (47).



(47) Rear Bearing



(46) Rear Wheel Axle

17 FIXING OF FLYWHEEL

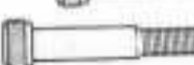
[Small Parts Used]

-  M3 x 10 Cap Bolt ...2
-  M3 x 25 Cap Bolt2
-  (49) Clutch Pin (Short)2
-  (50) Clutch Pin (Long)2

[Assembly of Flywheel]

Drive in the clutch pin into the flywheel 51.

(49) (50) Clutch Pin (Note) Use the long clutch pins for Irvine, Enya & HP.25VT engines. Use the short pins for the OS Max.

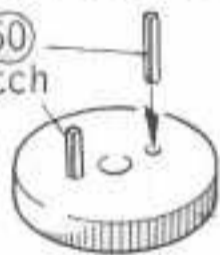

[Short pins for OS21]



[Long pins for Irvine and Enya]

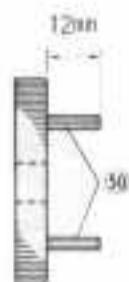

After assembling the flywheel parts as shown, bolt the muffler adapter to the engine as shown.

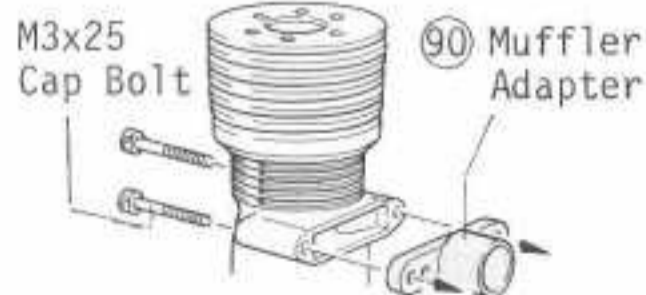

Note: For Enya engines you will have to widen one or both of the holes on the muffler adapter. For the Irvine, use the muffler screws provided with your engine.

16 FIXING OF SWING SHAFT

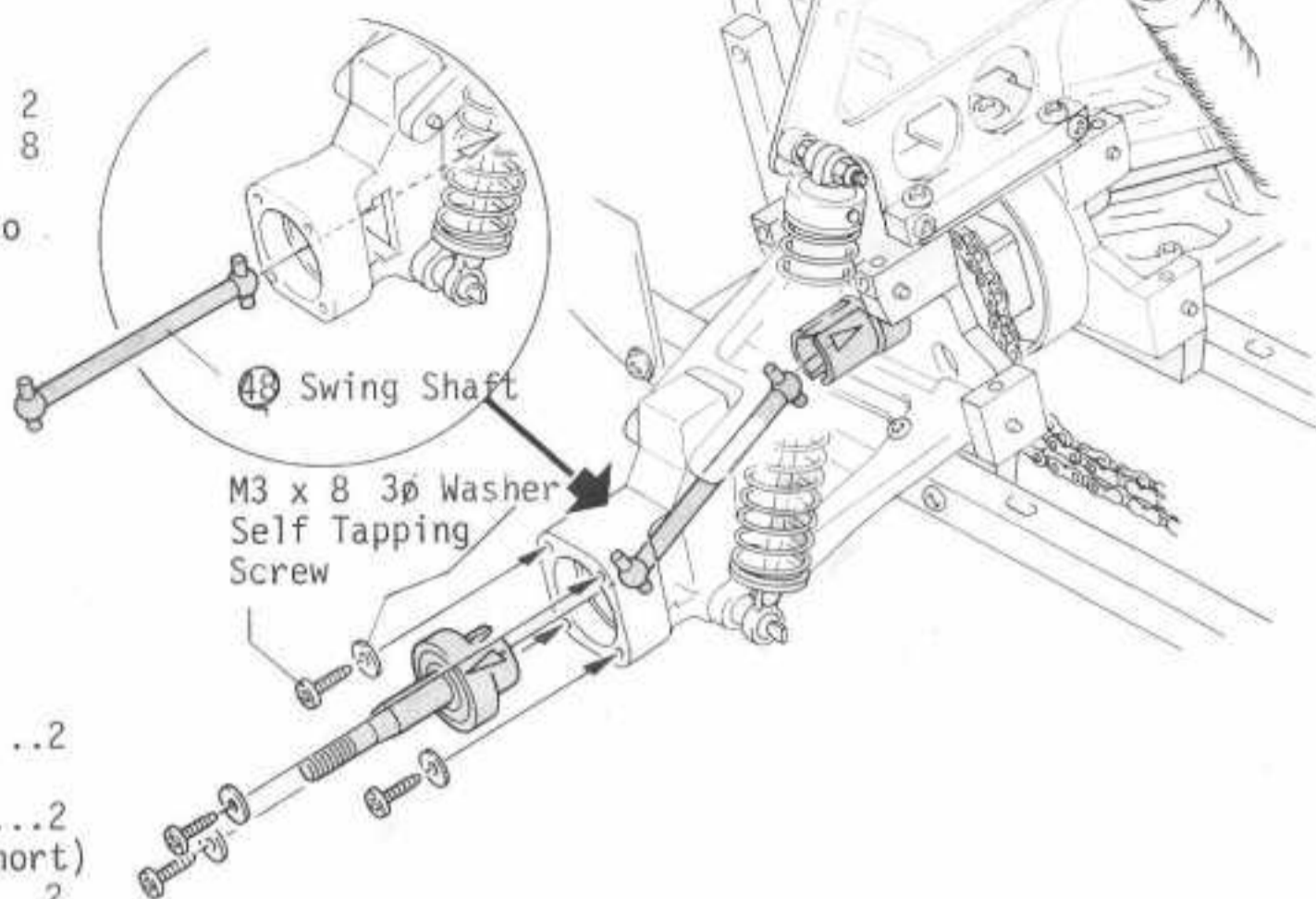

(48) Swing Shaft

M3 x 8 3ø Washer
Self Tapping
Screw

17 ASSEMBLY OF FLYWHEEL

[For the OS21 Side Exhaust]

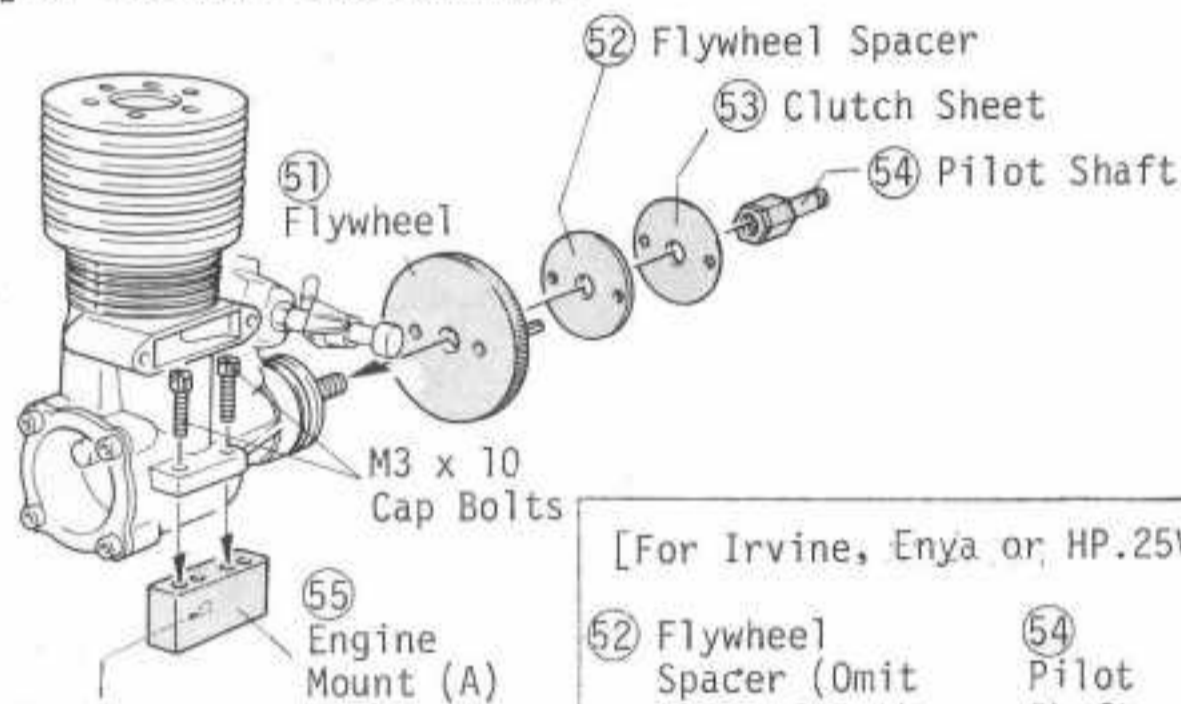

The circle mark should be located inside.

[For Irvine, Enya or HP.25VT]

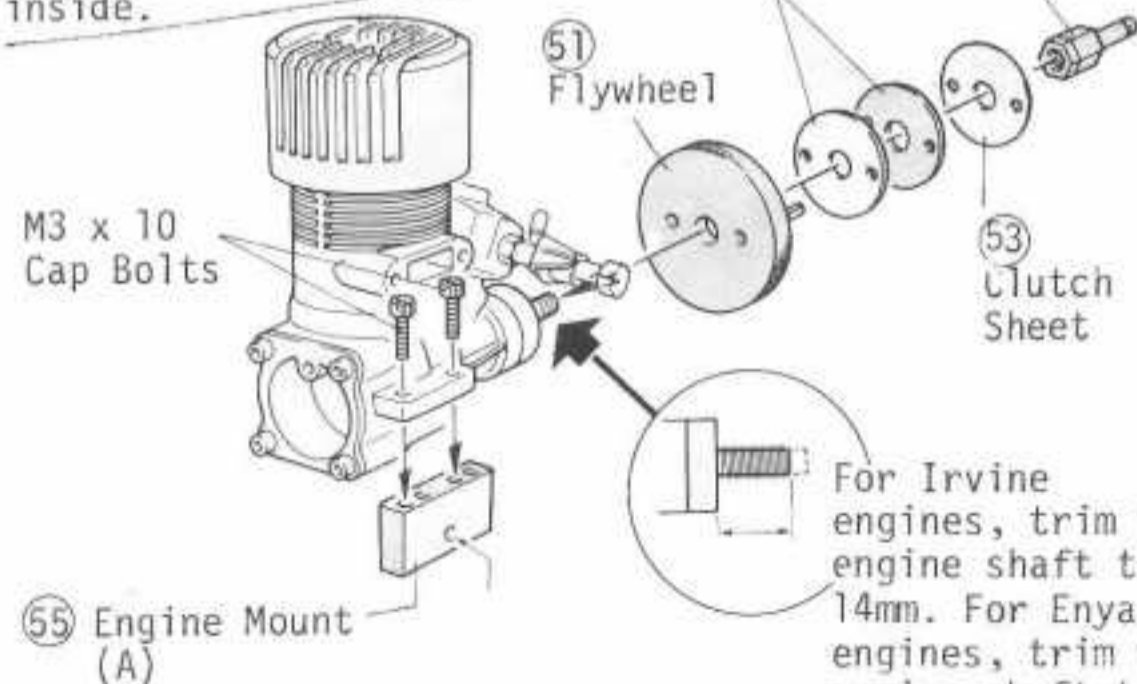

The circle should be outside.

For Irvine engines, trim the engine shaft to 14mm. For Enya engines, trim the engine shaft to 18mm.

Smooth off the end of the shaft before installation. No trimming is necessary with the HP.25VT.

18 INSTALLATION OF CLUTCH

[Small Parts Used]



80 Washer ... 1

[Assembly of Clutch]

Make a small "U" bend in the longer of the two clutch spring legs to help secure them into the pins of the flywheel.

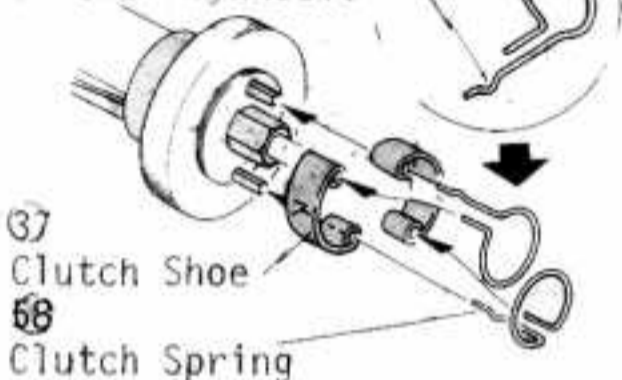

19 ASSEMBLY OF SPUR GEAR

[Small Parts Used]

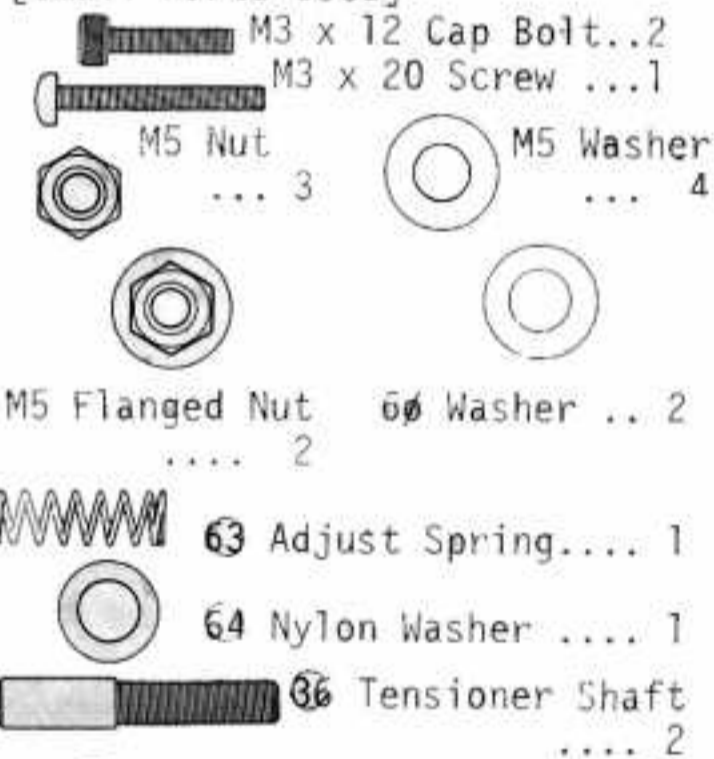

After having assembled as shown in the right side picture, install the tensioner guide.

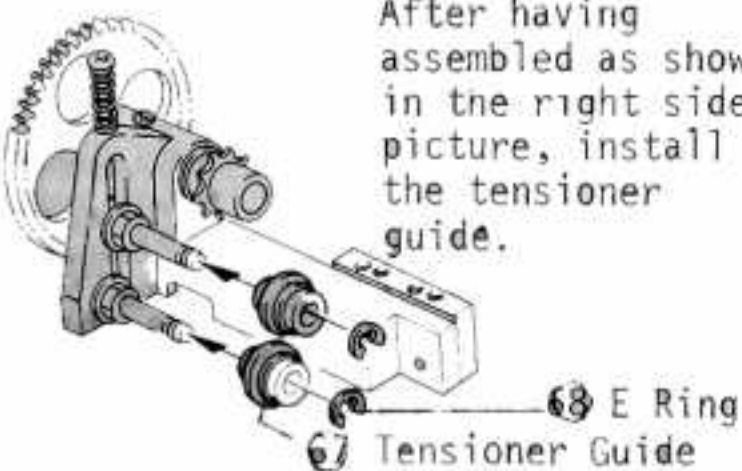

18 INSTALLATION OF CLUTCH

Do not cement the lining, just press it into the clutch bell.

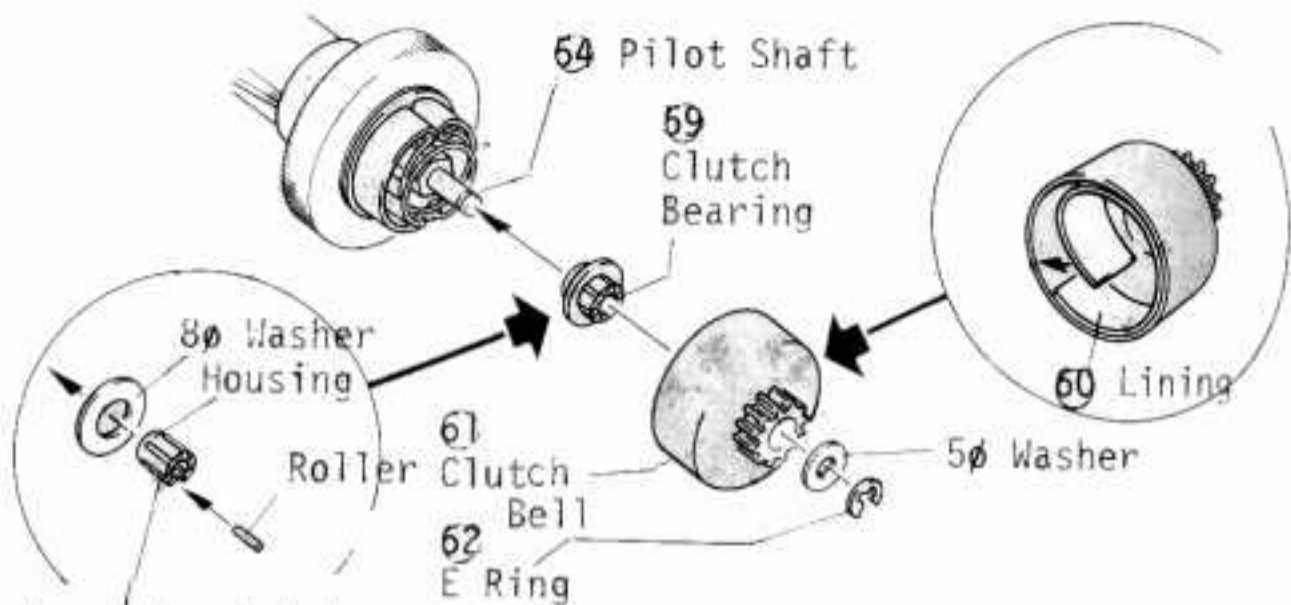

Keep the clutch bearing always oiled.

19 ASSEMBLY OF SPUR GEAR

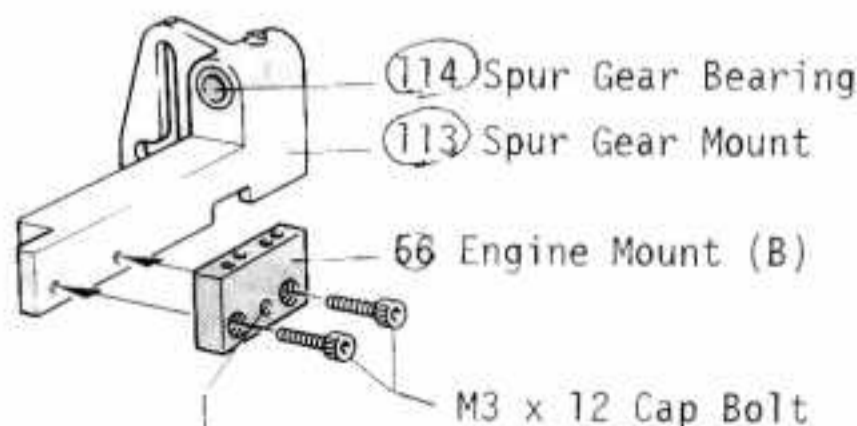
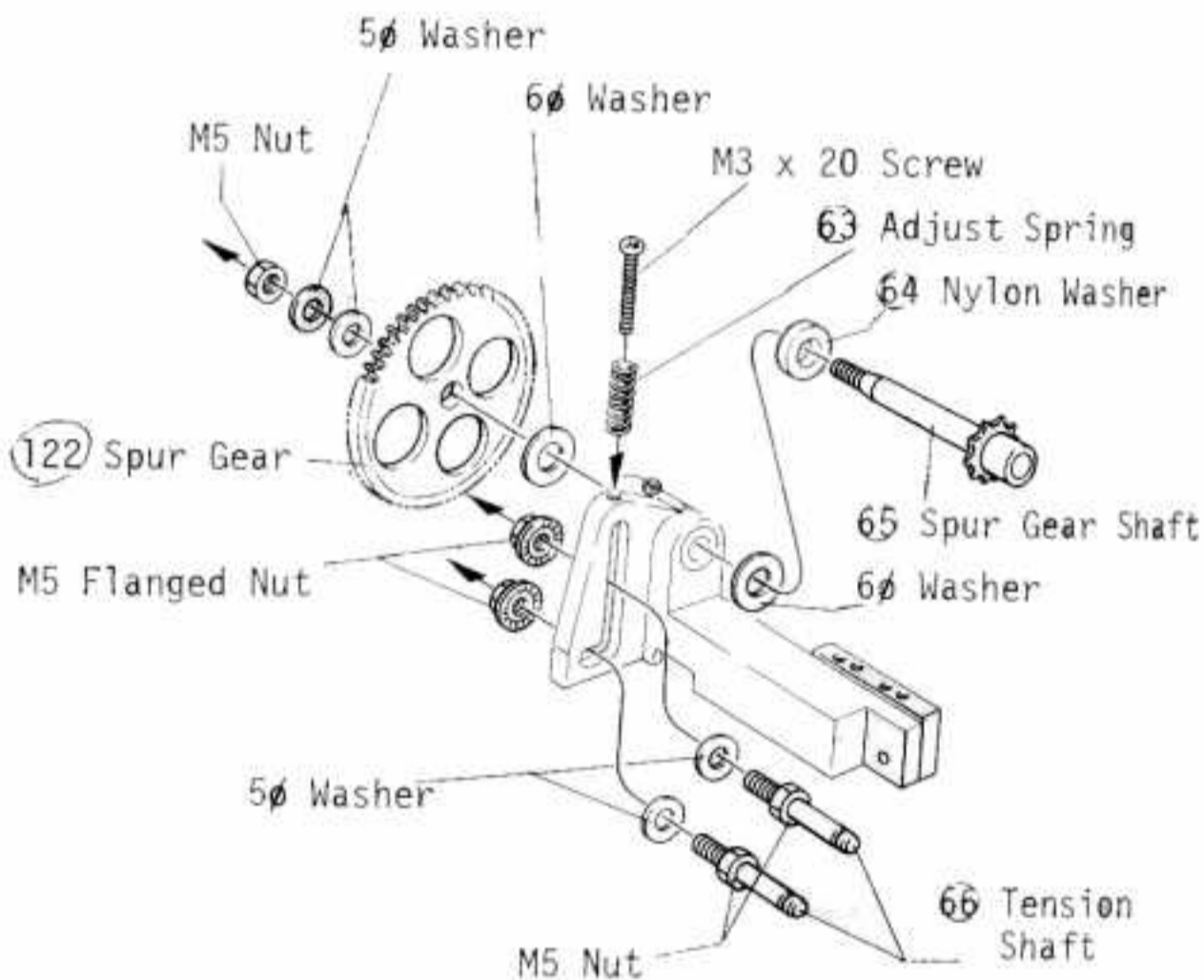

With the engine OS21, fix the engine mount with the circle mark facing outside; and with the Irvine, Enya 21CX or HP .25VT, put it the other way around.

20 ASSEMBLY OF SPUR GEAR MOUNT

[Small Parts Used]

 M3 x 16 Cap Bolt..2

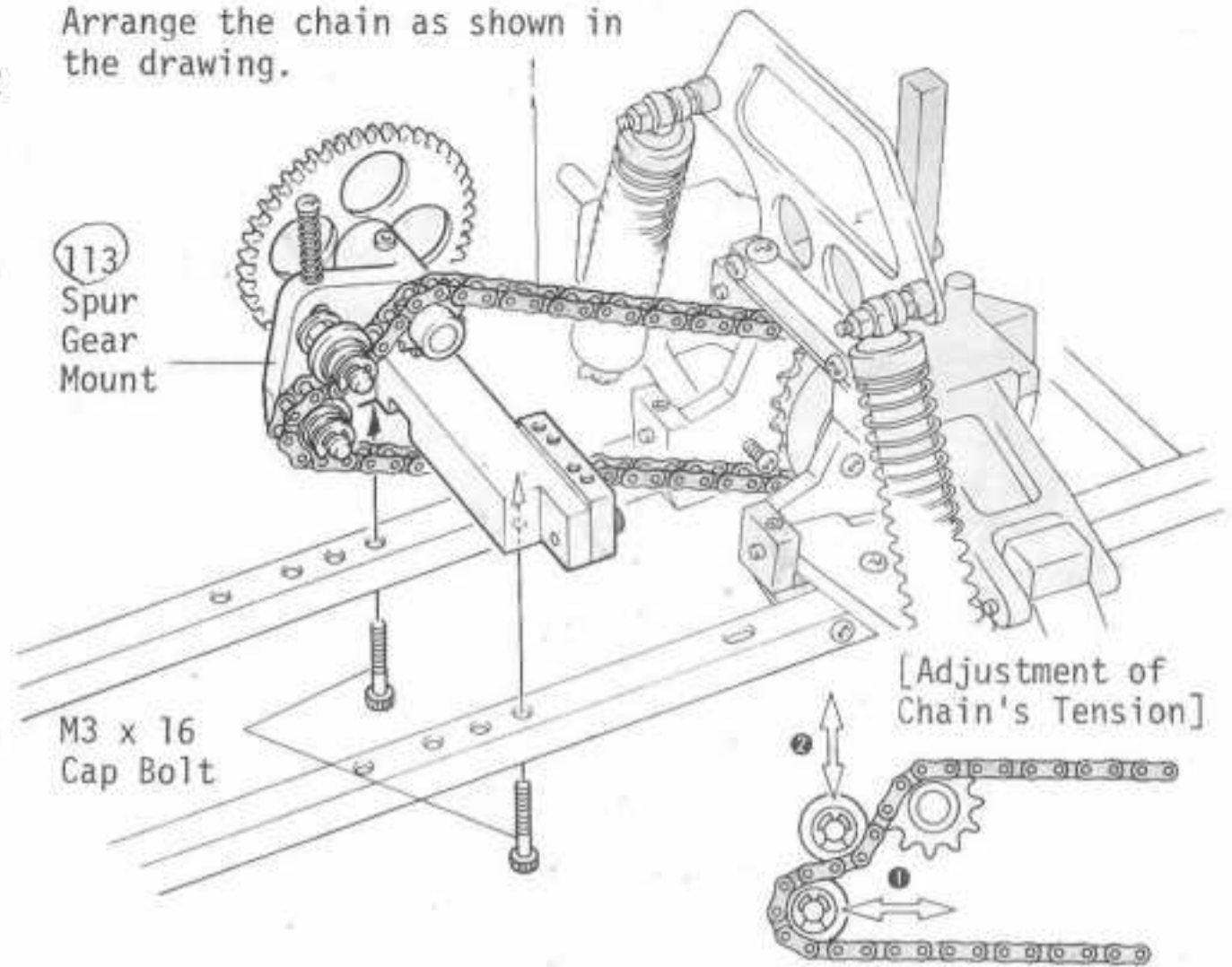

20 ASSEMBLY OF SPUR GEAR MOUNT

Arrange the chain as shown in the drawing.



21 MOUNTING OF ENGINE

[Small Parts Used]

 M3 x 10 Cap Bolt ... 2
 M3 x 16 Cap Bolt ... 1
 3φ Washer ... 1

Adjust the backlash between the clutch bell (6) and the spur gear (22) by loosening the engine mounting bolts.

21 MOUNTING OF ENGINE

Adjust the tension of the chain by sliding the tensioner shafts 66 toward 1 and 2. (See page 22 for details)

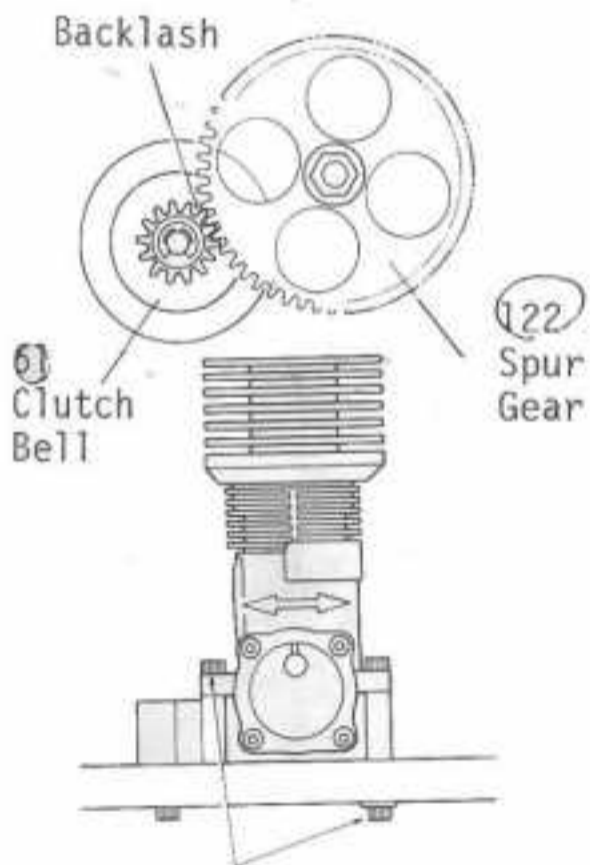

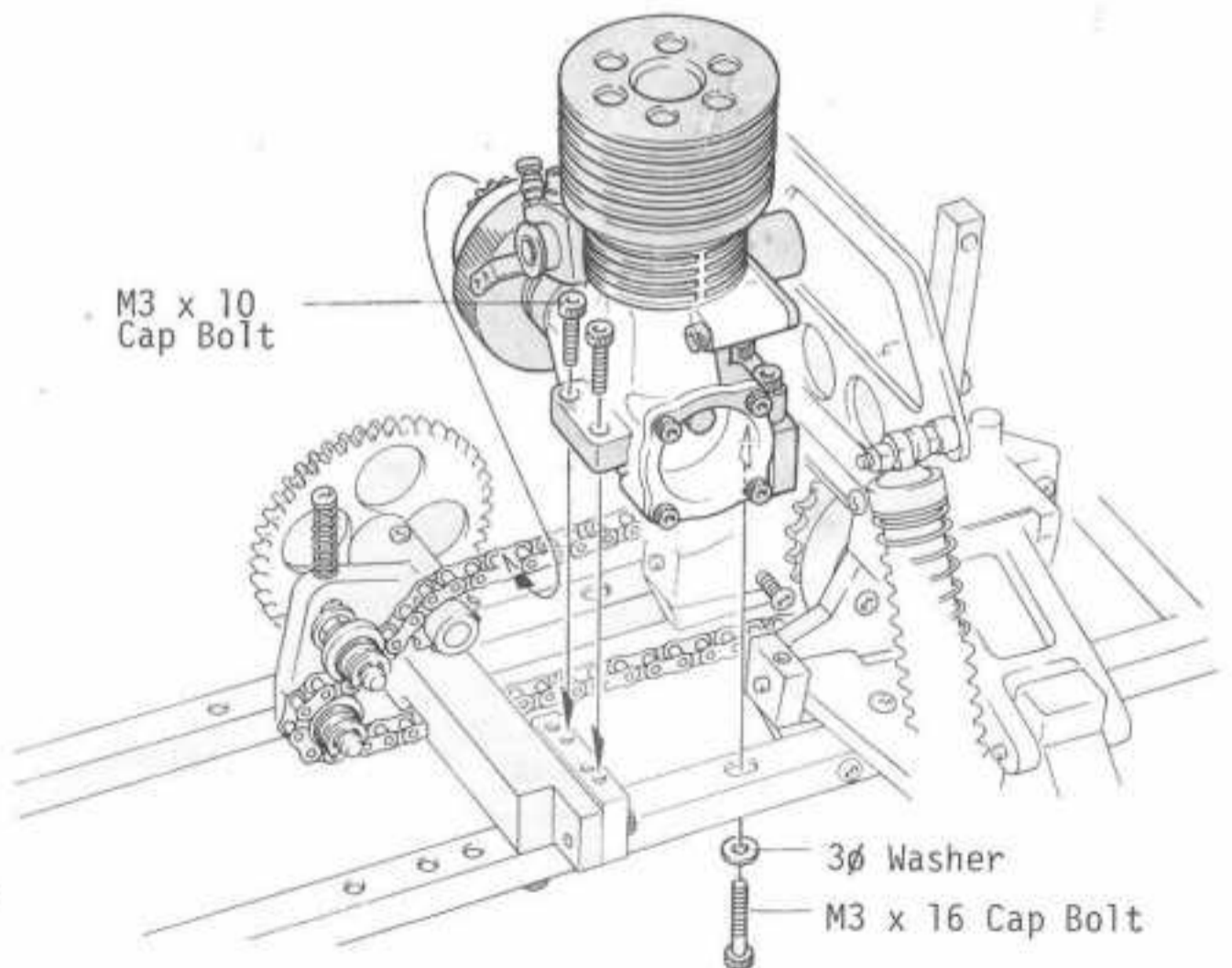

Loosen three cap bolts for the adjustment. After Adjusting, Retighten the bolts.



22 INSTALLATION OF ENGINE CONTROL SERVO SAVER

[Small Parts Used]

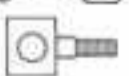
-  M3 x 16 Screw 1
-  M2 Nut 2
-  M4 Nylon Nut 1
-  69 Linkage Guide . 2

Fix the linkage guide 69 to the engine control servo saver 71.

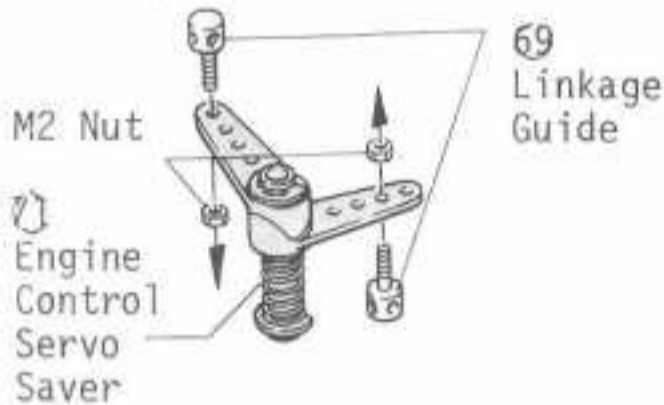

23 MOUNTING OF SERVOS

[Small Parts Used]

-  M3 x 10 Screw ... 2
-  M3 x 16 Screw ... 4
-  M4 x 40 Screw.. 1
-  M3 x 12 Self Tapping Screw 8
-  M3 Flange Nut 2
-  M4 Nut 1

Cut off part of the shaded portion according to the servo, and drill the holes for the mounting bolts.

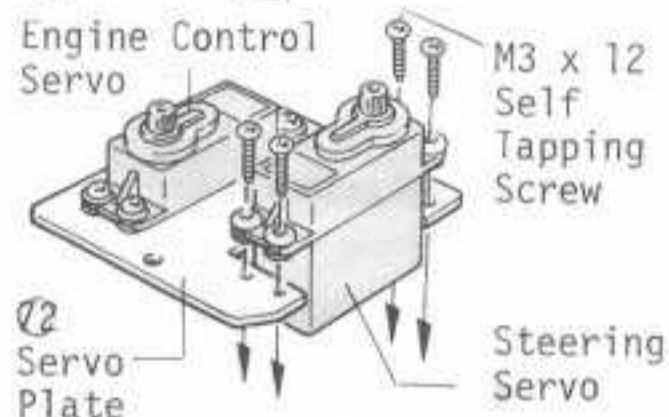
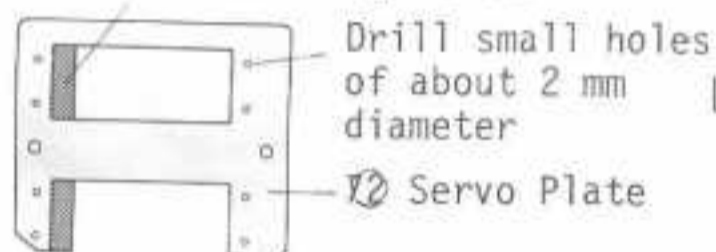

22 INSTALLATION OF ENGINE CONTROL SERVO SAVER

M4 Nylon Nut

71 Engine Control Servo Saver

70 Engine Control Servo Saver Shaft

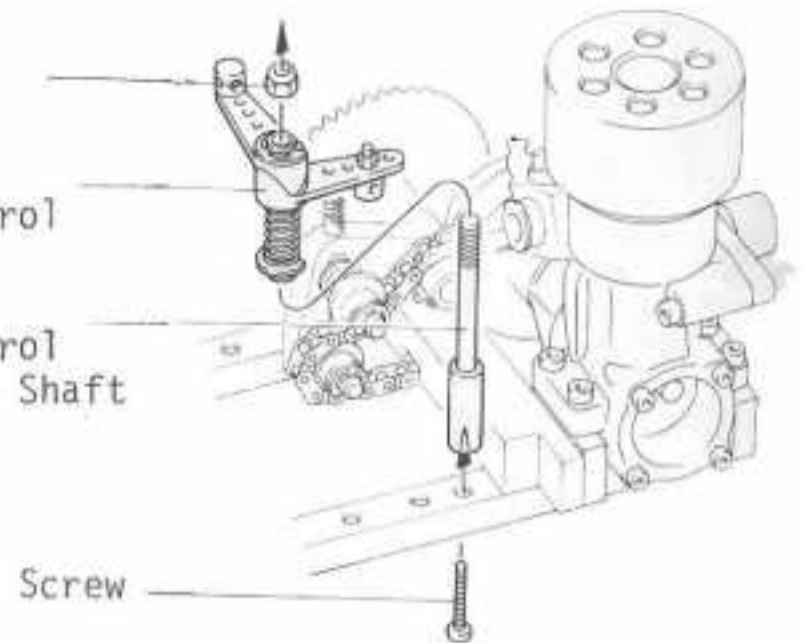

23 MOUNTING OF SERVOS

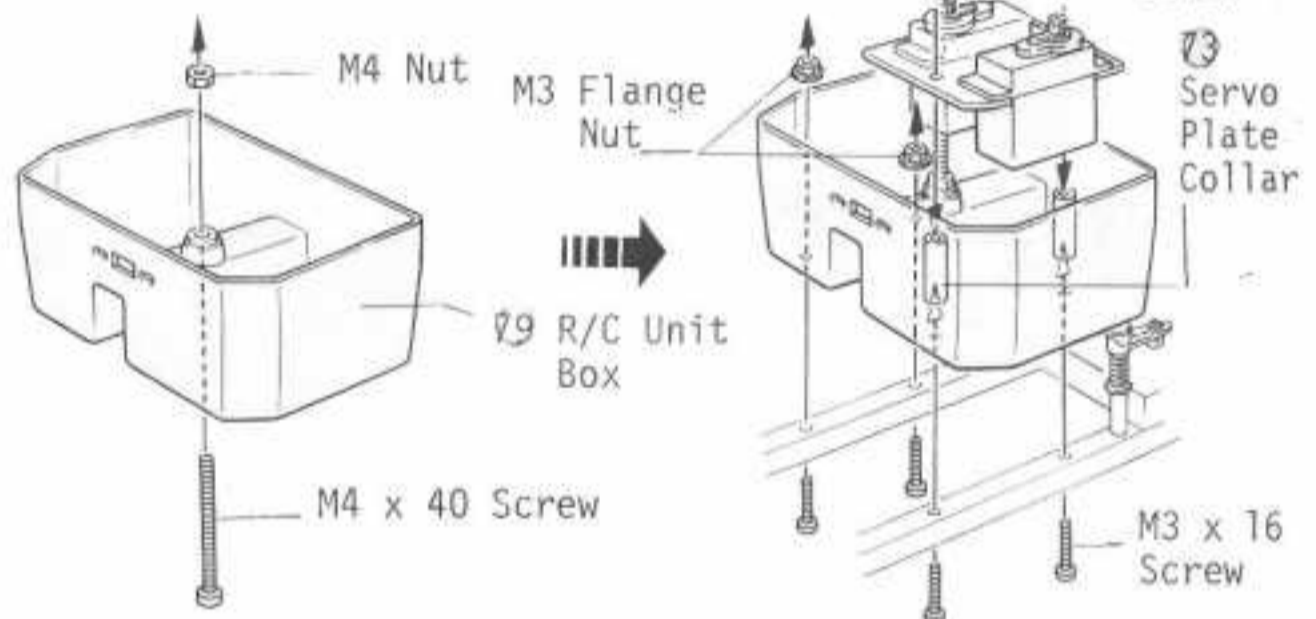

24 LINKAGE FOR STEERING CONTROL

[Cutting of Servo Horn]

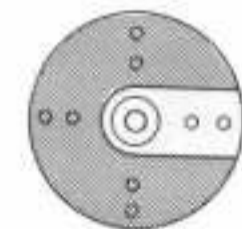

Cut off the shaded portion.

Screw provided with Your Radio

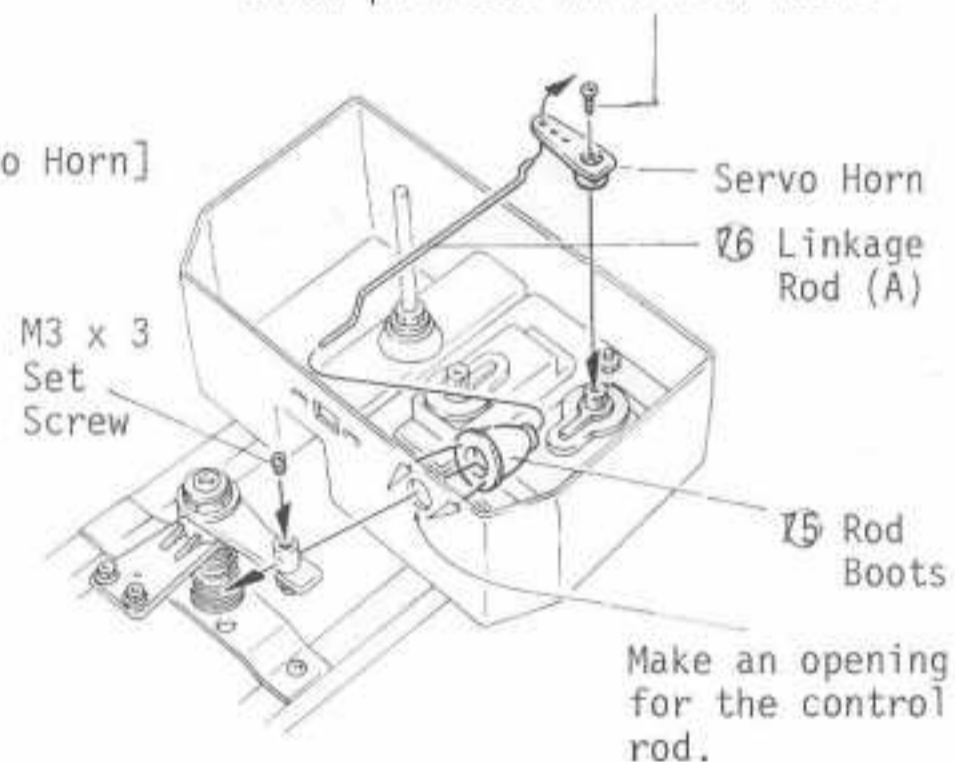

24 LINKAGE OF STEERING CONTROL

[Small Parts Used]

-  M3 x 3 Set Screw 1

(Note) Arrange the linkage of the control rods while keeping the servo and front wheels in the neutral position.



Put together the rubber boot for the control rod by cementing the parts.

*Assemble two sets of them.



25 LINKAGE OF ENGINE CONTROL

[Small Parts Used]

-  M3 x 3 Set Screw ..4
-  74 2φ Stopper3
-  78 Linkage Spring..1

25 LINKAGE OF ENGINE CONTROL

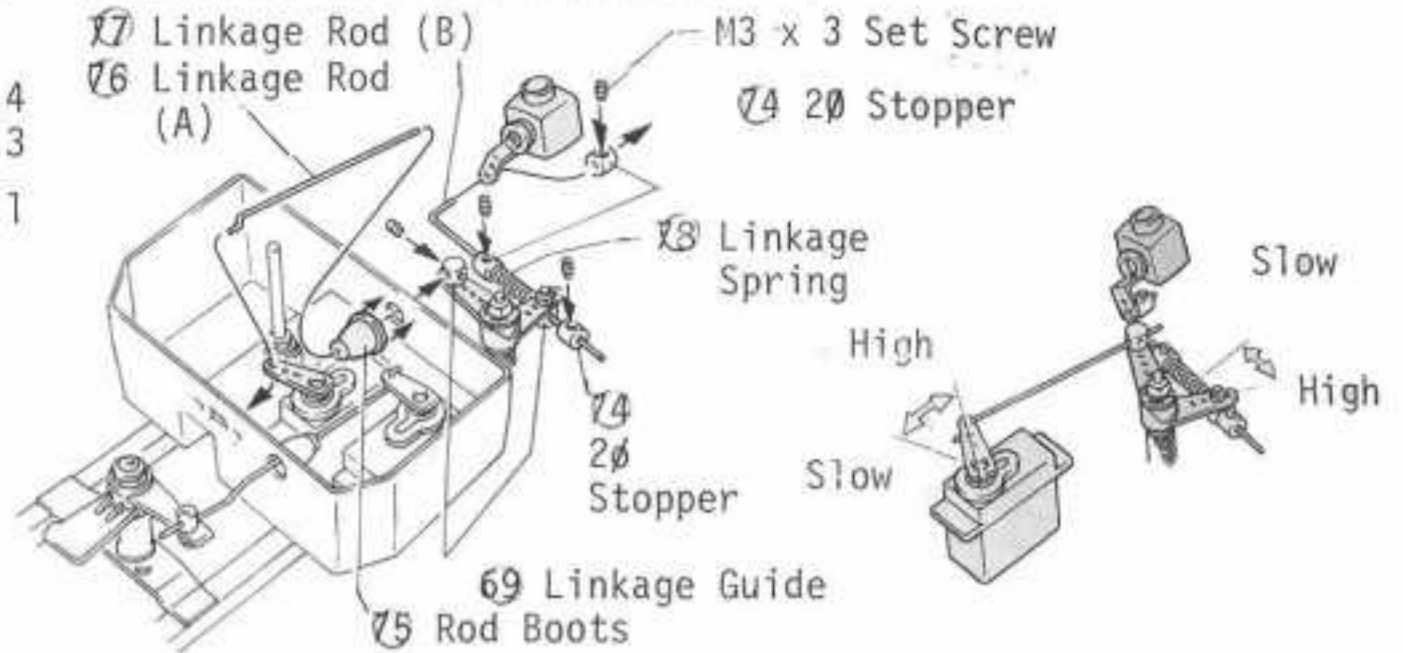

If you have an HP .25 VT/car engine you must use a ball link similar to the dubro #191 for the carb linkage. It would then hook up similar to the Enya installation shown at right.

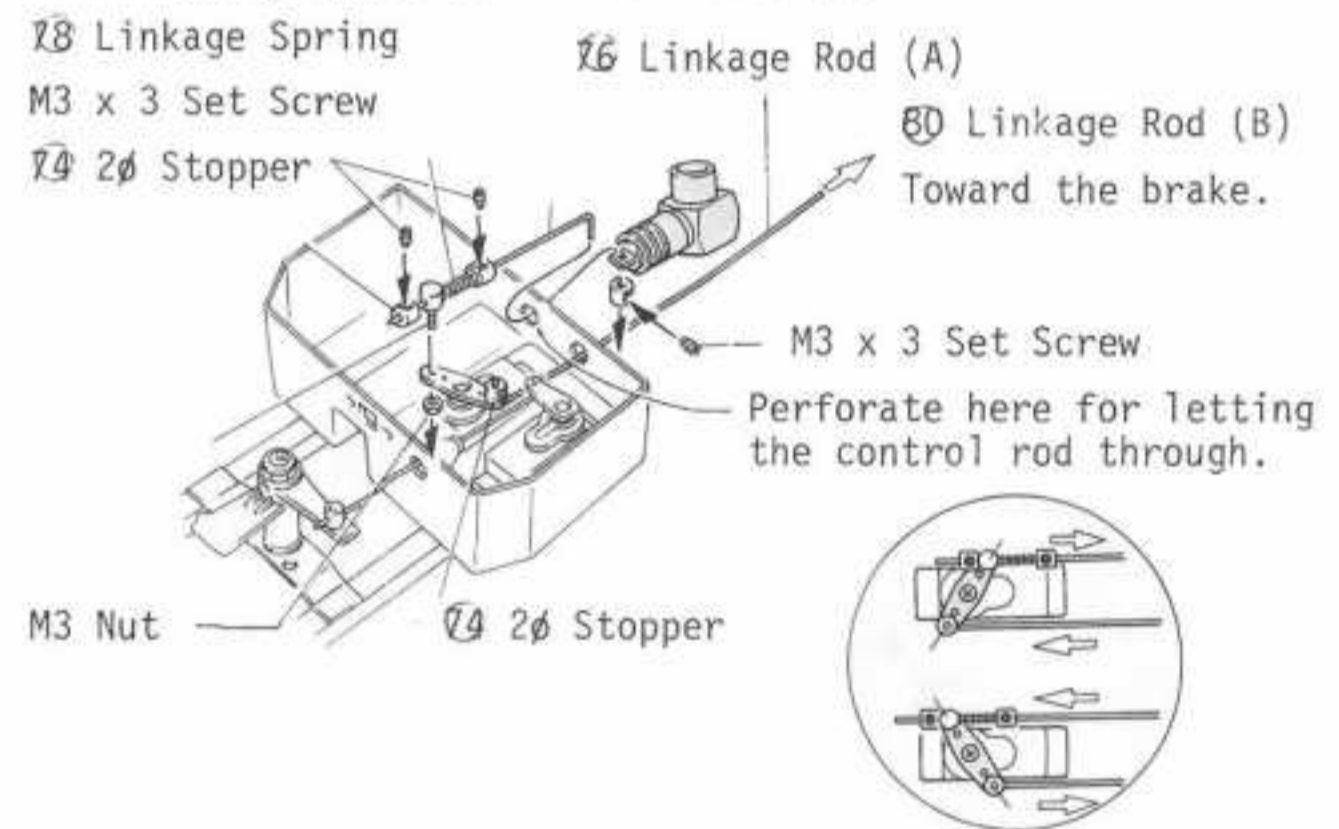

[Linkage for Enya Slide Carb]

(Note:) When slide carburetor is employed, arrange the linkage as shown in the drawing below; the servo, in this case, should be reverse rotation.



26 LINKAGE OF BRAKE SYSTEM

[Small Parts Used]

-  M3 x 3 Set Screw ..2
-  74 2φ Stopper

26 LINKAGE OF BRAKE SYSTEM

The braking effect can be adjusted by loosening the stopper setscrew under the chassis and shifting the position of the Stopper.

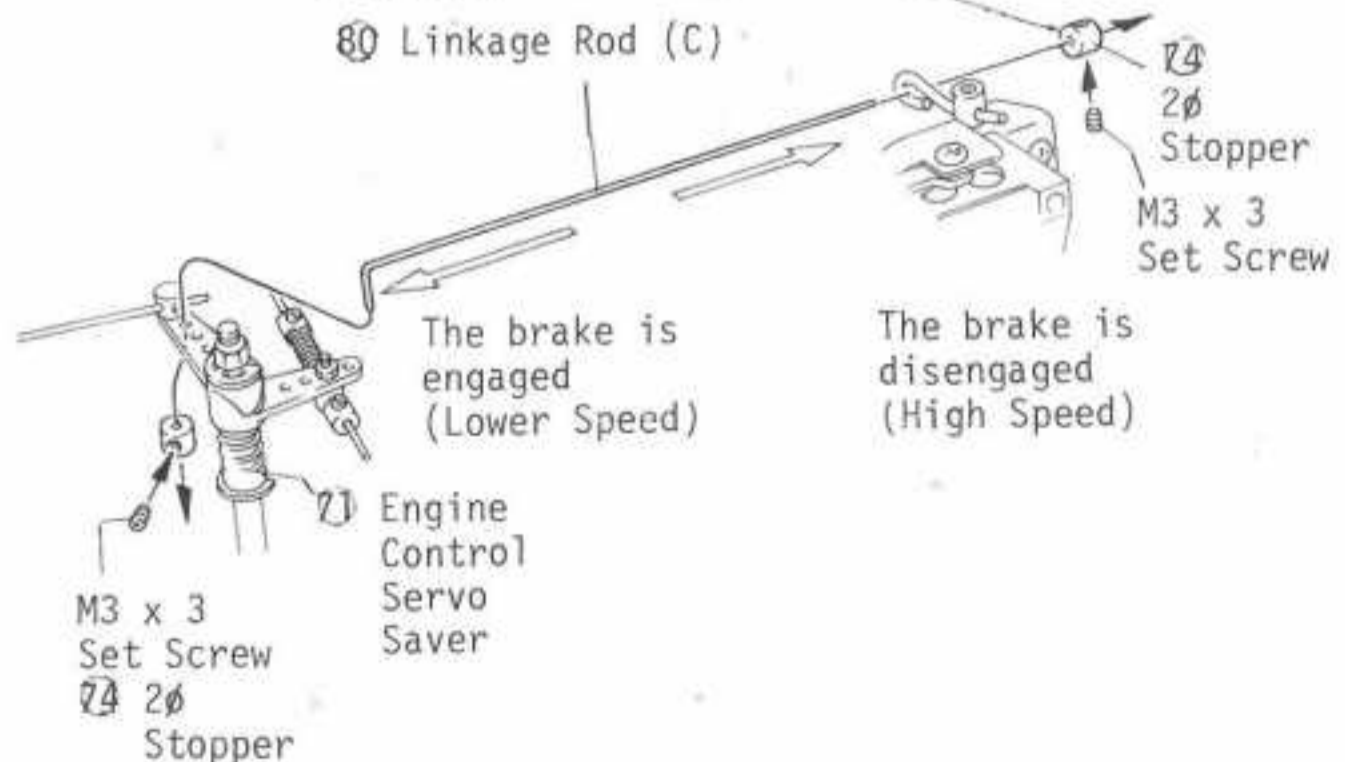

27 MOUNTING THE MUFFLER

[Small Parts Used]

⊗ M4 Nut 2

⊗ 83 Pressure Nipple. 1

[Assembly of Muffler]

M4 Nut 84 Muffler (A)
85 Baffle

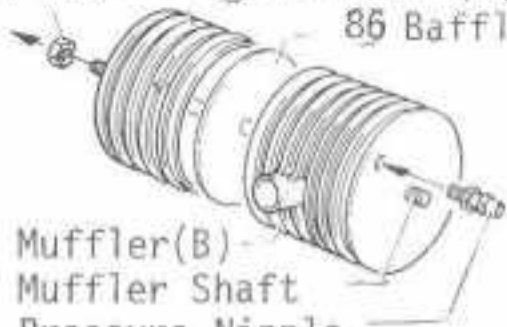

85 Muffler(B)
87 Muffler Shaft
83 Pressure Nipple

Set the exhaust outlet upward as shown in the drawing.

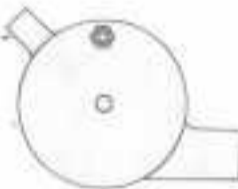

[Assembly of Fuel Tank]

⊗ 119 Fuel Tank Cap
⊗ 118 Fuel Tubing
⊗ 116 Fuel Pipe
⊗ 117 Fuel Tank Bushing
⊗ 115 Fuel Tank

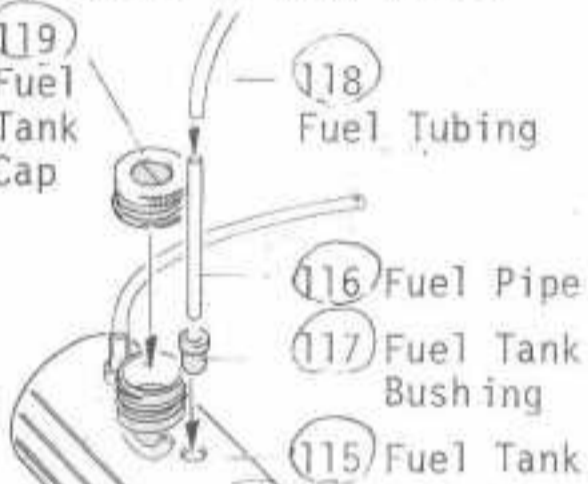

Air Vent (Bend it as shown in the drawing)

Arrange the tubing mouth close to the bottom.



27 MOUNTING THE MUFFLER

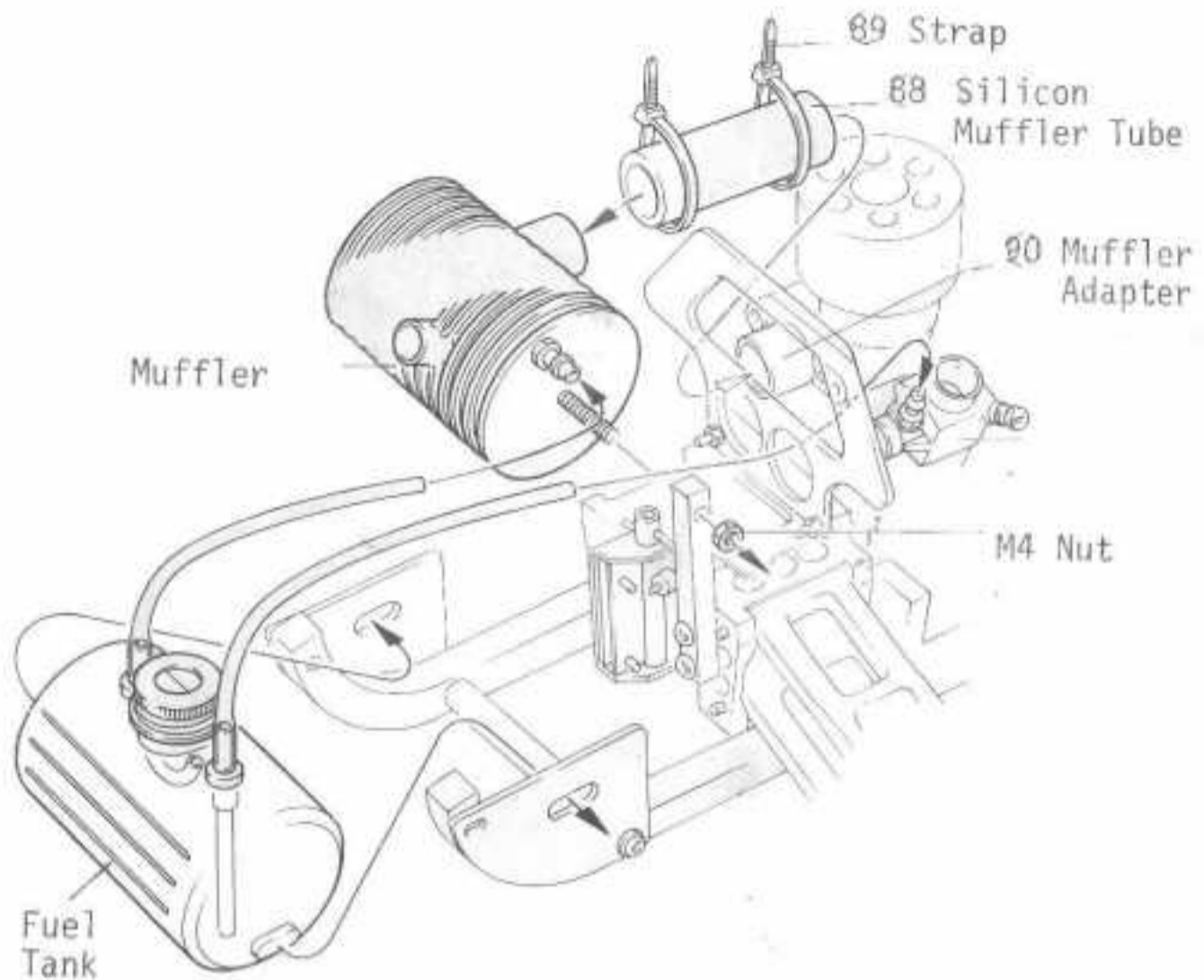

28 MOUNTING THE RADIO CONTROL UNITS

28 MOUNTING THE RADIO CONTROL UNITS

[Fixing of R/C Unit Switch]

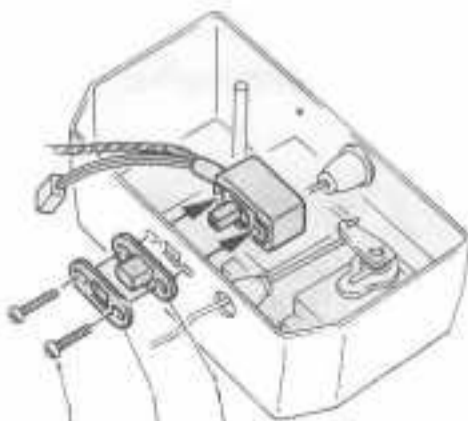

⊗ 81 Switch Boot
82 Switch Plate

Use the screws furnished with the switch.

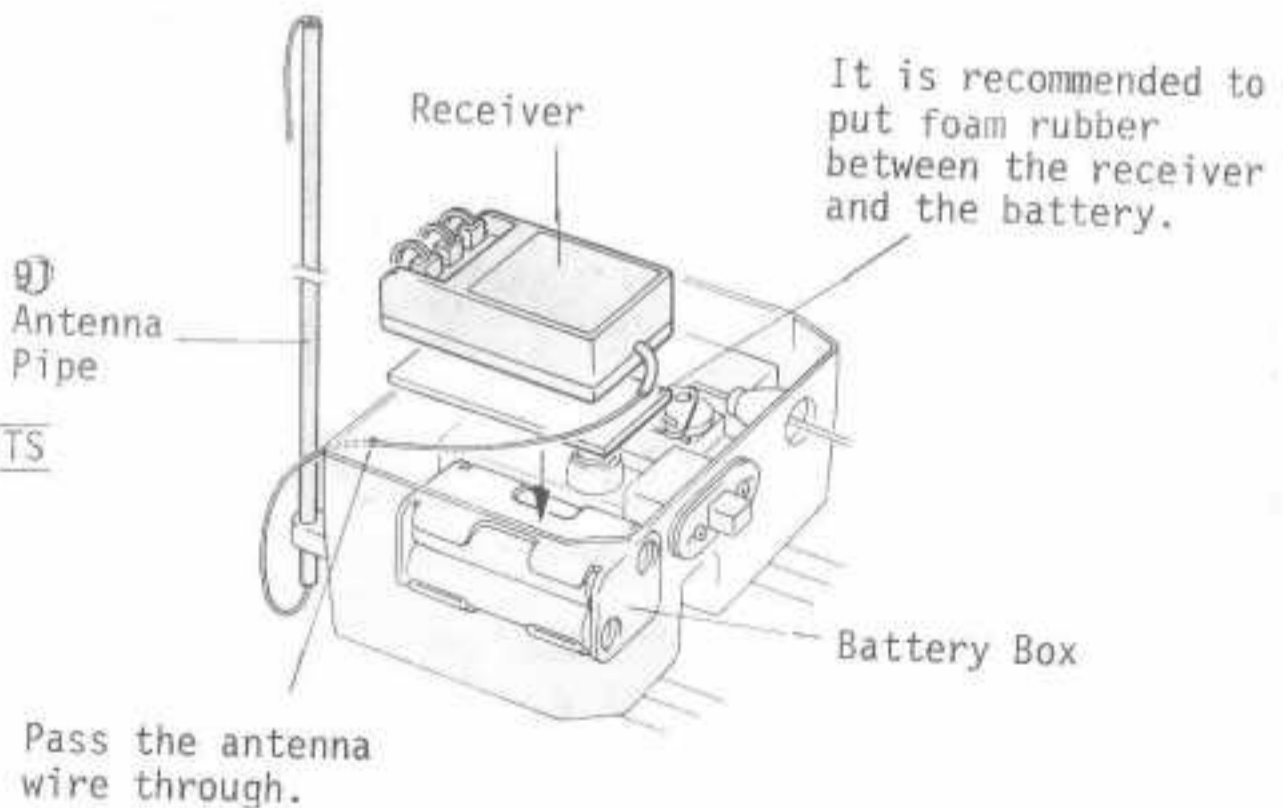



It is recommended to put foam rubber between the receiver and the battery.

Pass the antenna wire through.

29 ATTACHING THE BUMPER

29 ATTACHING THE BUMPER

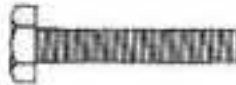
[Small Parts Used]

-  M4 x 20 Bolt 2
-  M4 Nut 2
-  4ø Washer 2

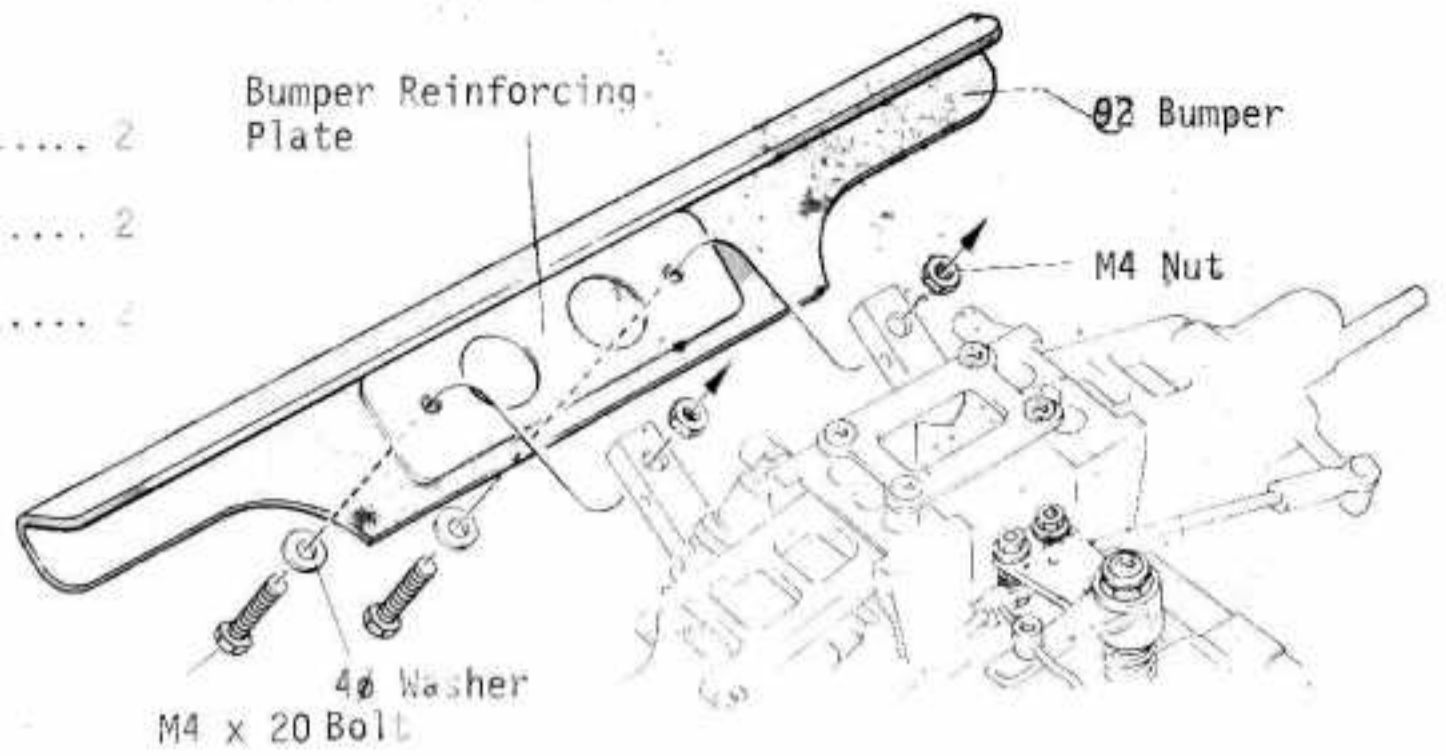

30 CEMENTING THE TIRES

30 CEMENTING THE TIRES

Align the outside edge closely.

[Front]

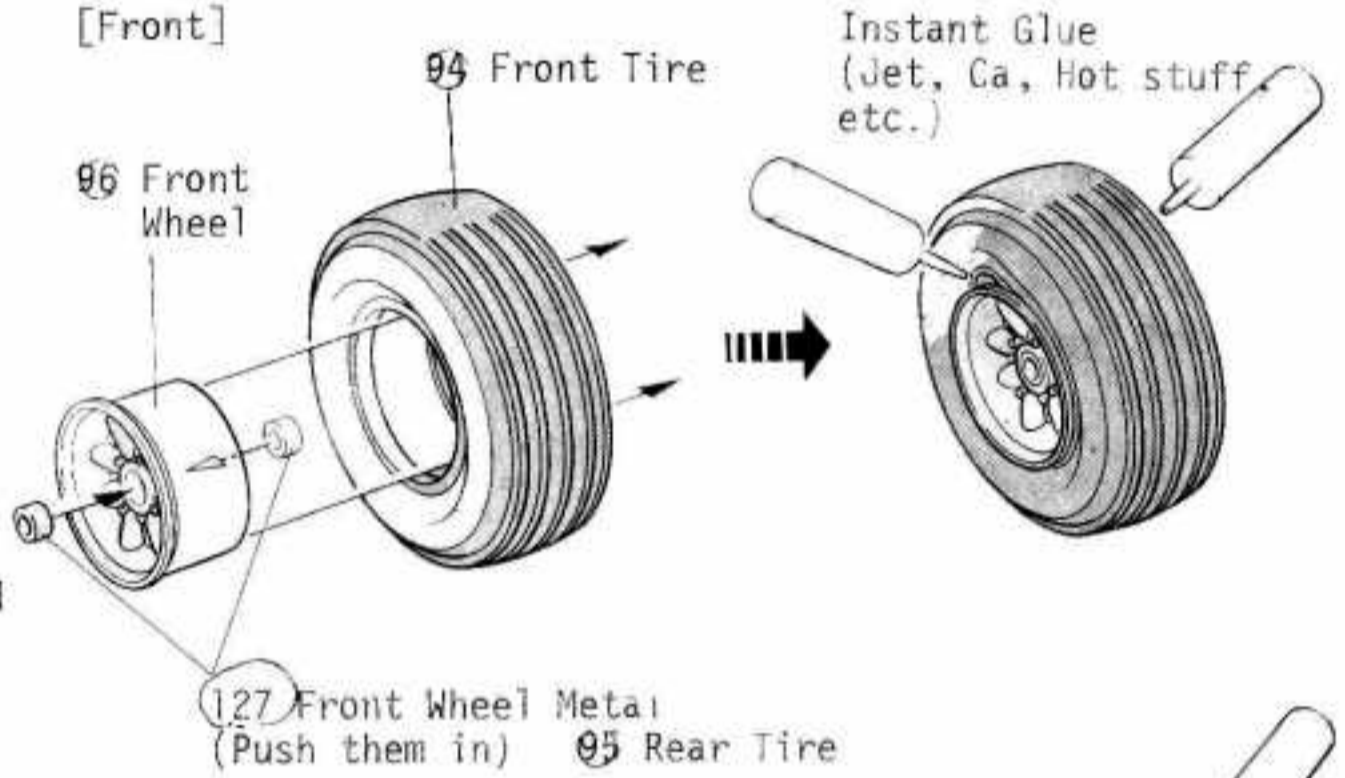
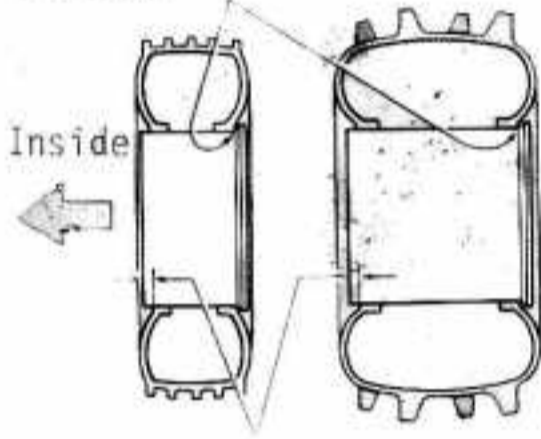

The inside edge of the wheel should protrude 2 to 3 mm inward.

[Small Parts Used]

-  127 Front Wheel Metal 4

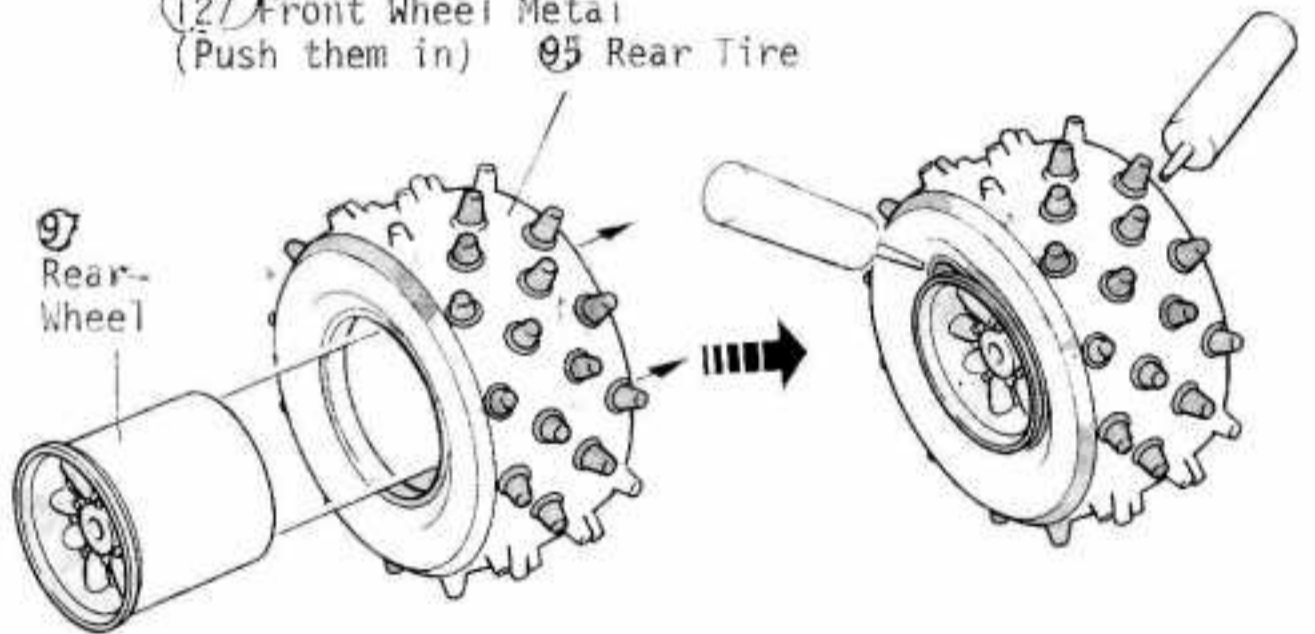

31 INSTALLATION OF WHEELS

[Small Parts Used]

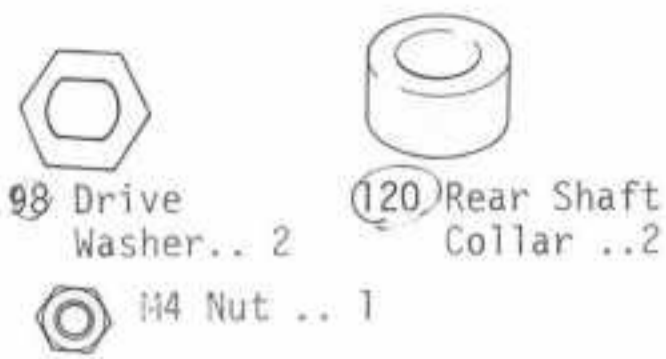

31 INSTALLATION OF WHEELS

[Small Parts Used]

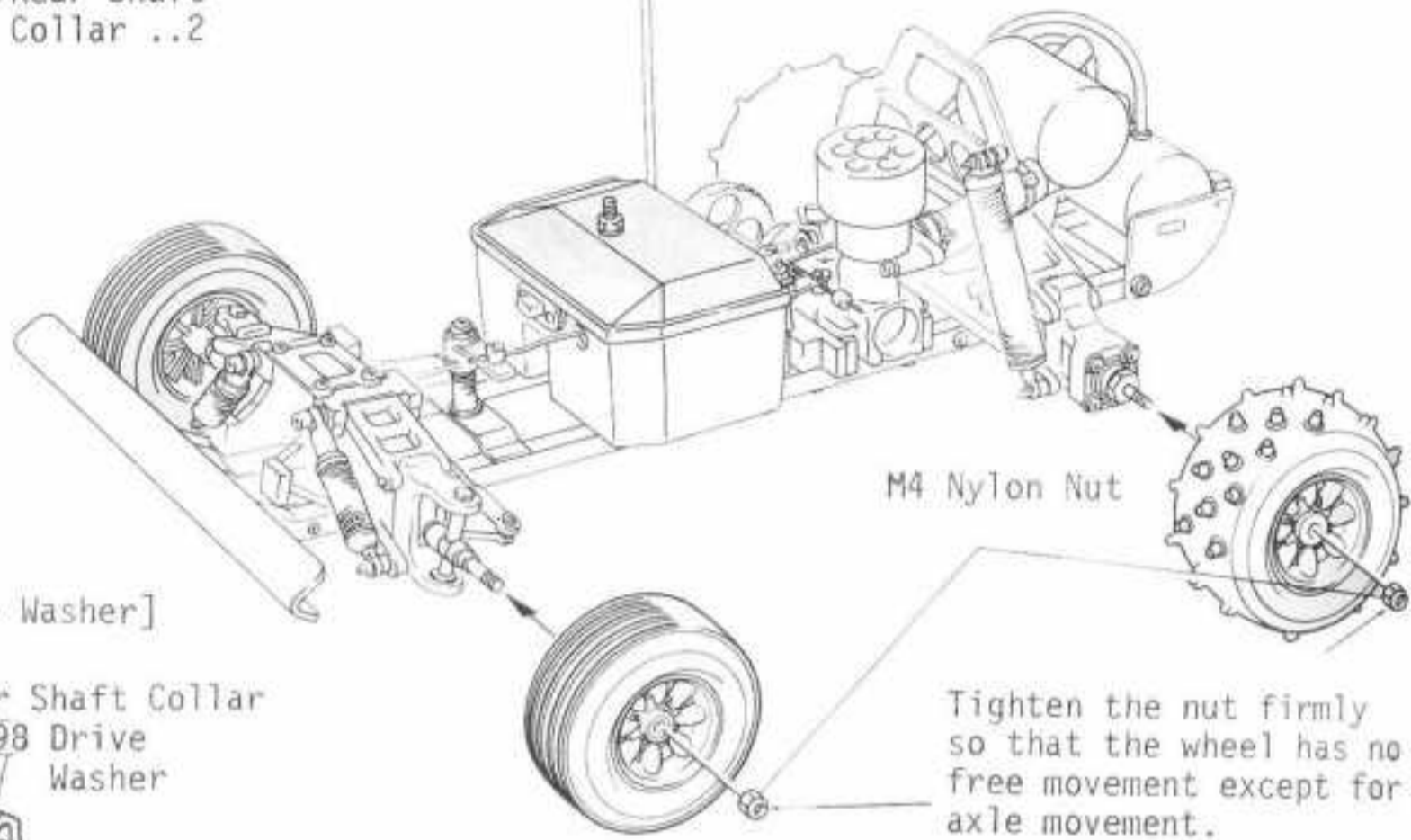
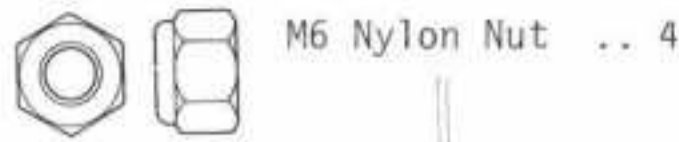

[Attaching the Drive Washer]

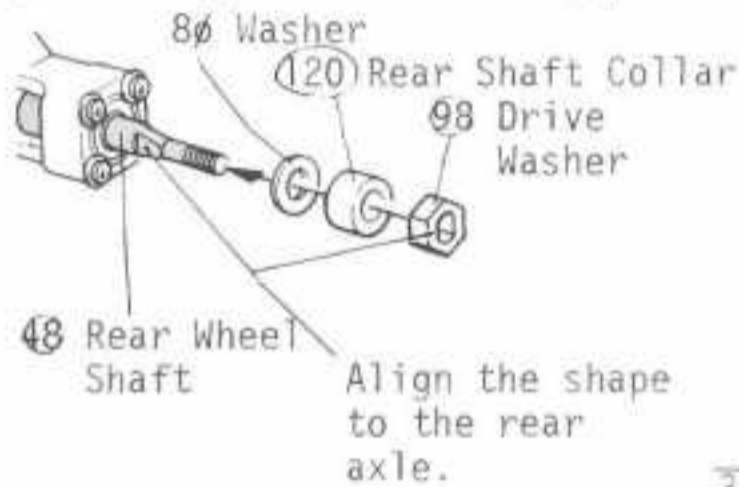

32 TRIMMING THE IMPACTA BODY

Cut off the portion indicated with with a knife or scissors.

Drill a hole of 4 mm diameter

99 Impacta Baja Body

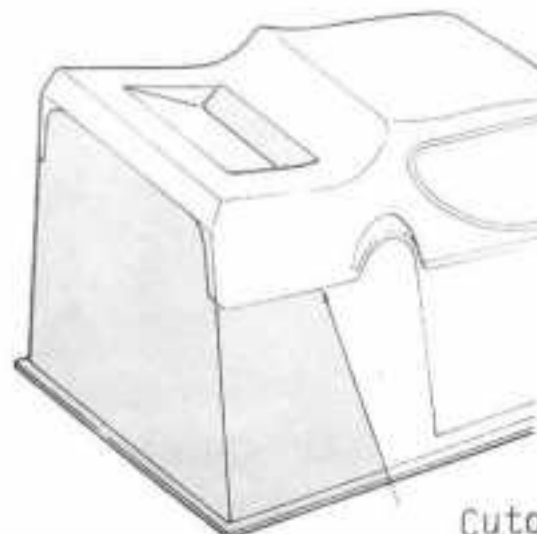
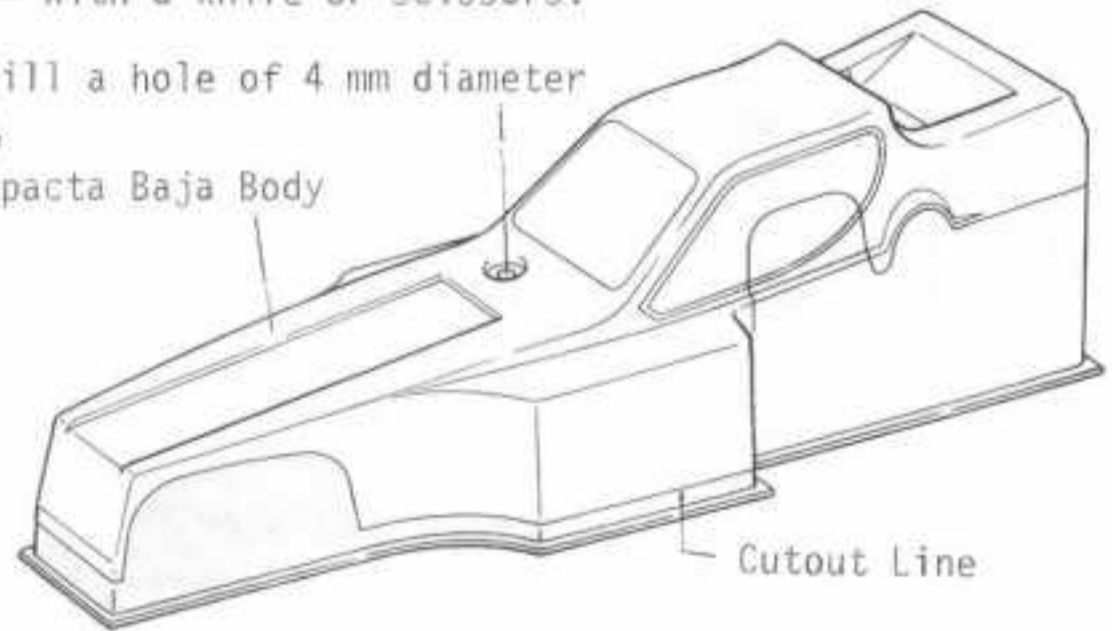

Note: Only cut away the shaded portions. Don't follow the decorative trim lines of the body. You may end up cutting too much!

[Attaching Radio Box Cover]

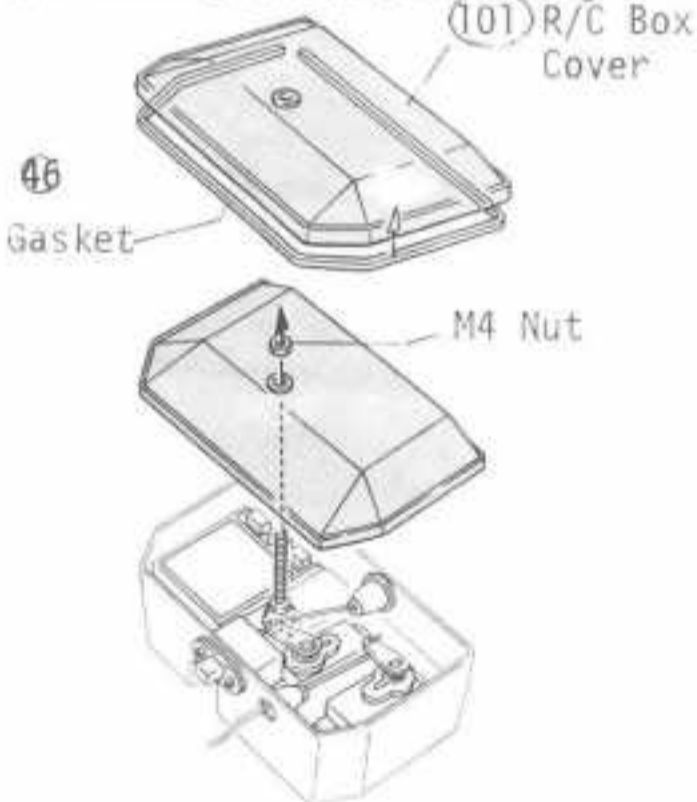

32 TRIMMING THE IMPACTA BODY

[Cut the Rear Portion of the Body as shown]

33 PAINTING BODY (IMPACTA BAJA TYPE)

The body of the Impacta (the Mint features a roll cage) is made from clear plastic. The best looking paint job can be had by painting the INSIDE of the body. Before painting, wash the body with a mild detergent (like dishsoap) and warm water to remove any residual manufacturing oils. Make sure the body is completely dry before painting.

Use a high quality, fuel proof, plastic-type paint (such as pactra's Formula-U). Regular model enamels will dissolve and flake off.

33 PAINTING BODY (IMPACTA BAJA TYPE)

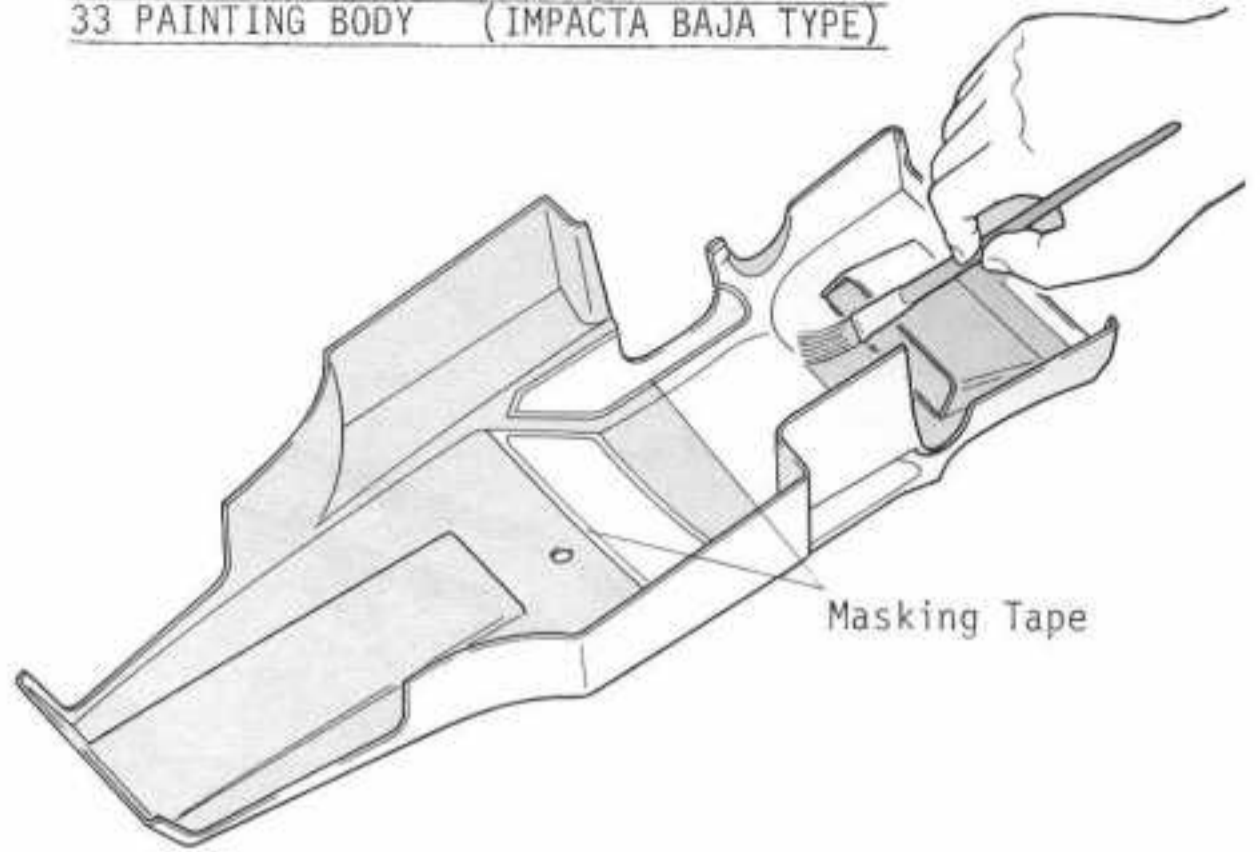



34 MOUNTING THE BODY (IMPACTA BAJA TYPE)

34 MOUNTING THE BODY

(Impacta Baja Type)

[Small Parts Used]

-  M3 x 16 Screw.. 2
-  M3 x 20 Flange Screw.. 2
-  (100) Fastening Knob. 1

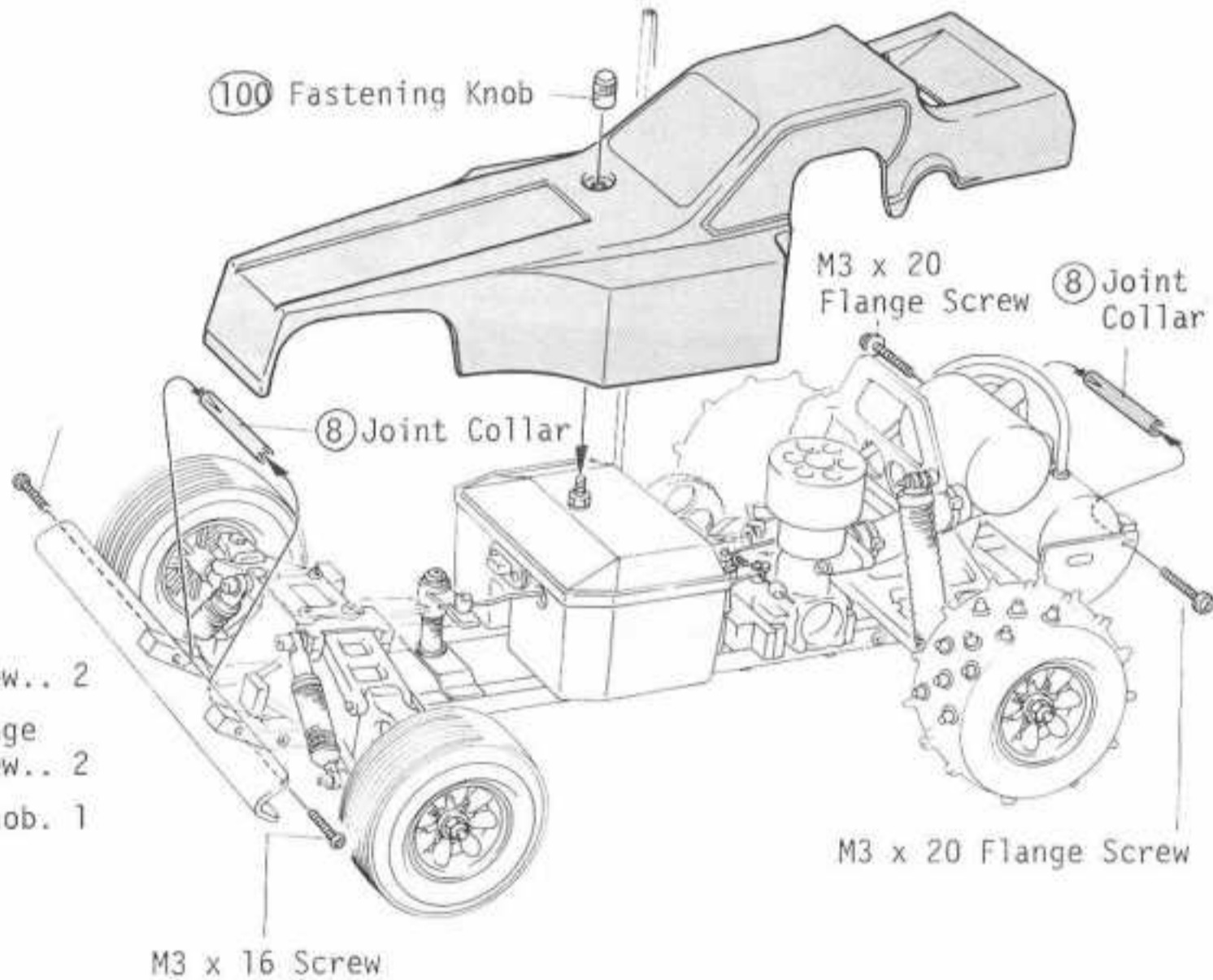

Before painting the rollcage of the Mint Baja, be sure that all of the mounting holes on the cage align properly with those on the chassis. If they do not line up, it is easier to bend them to fit now, before the cage is painted.

Before painting, wash the cage with a mild detergent (like dishsoap) and warm water to remove any residual manufacturing oils. Make sure the cage is completely dry before painting. Use a high quality, fuel proof paint (such as pactra's Formula-U). Regular model enamels will dissolve and flake off.

104 Roll Bar Cage

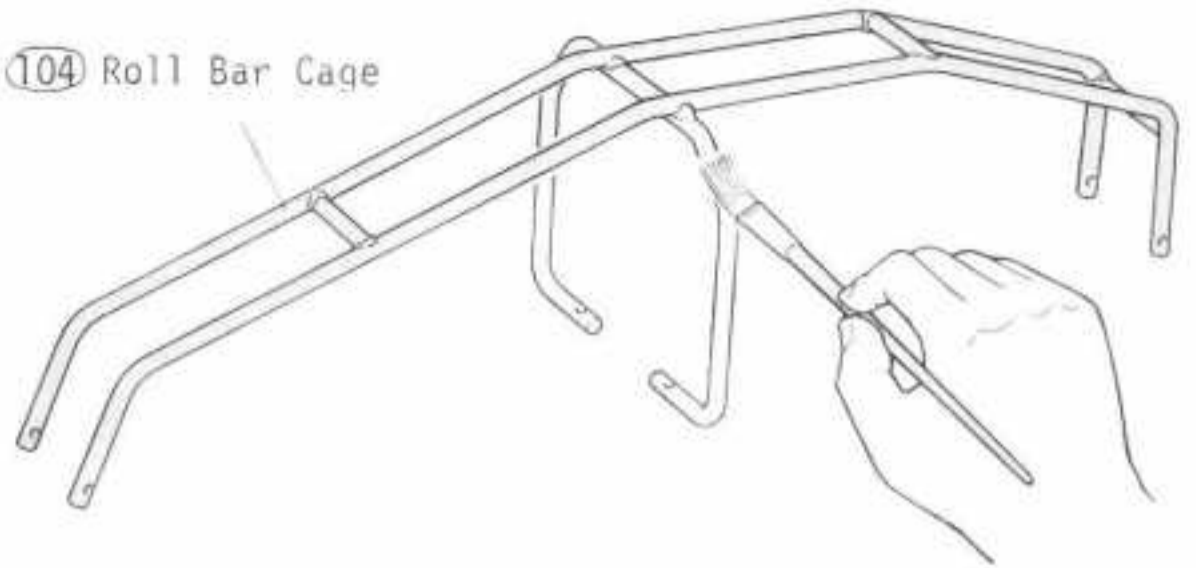

[Processing and Painting the Driver]

The driver figure is made from clear plastic. The best looking paint job can be had by painting the INSIDE of it.







103 Driver



36 INSTALLATION OF ROLL CAGE

(Mint Baja Type)

[Small Parts Used]

-  M3 x 20 Screw...2
-  M3 x 25 Flange Screw...4
-  M3 Nut2
-  3ø Washer2
-  100 Fastening Knob1

104 Roll Bar Cage of Mint Baja

105 Joint Collar B

M3 x 25 Flange Screw

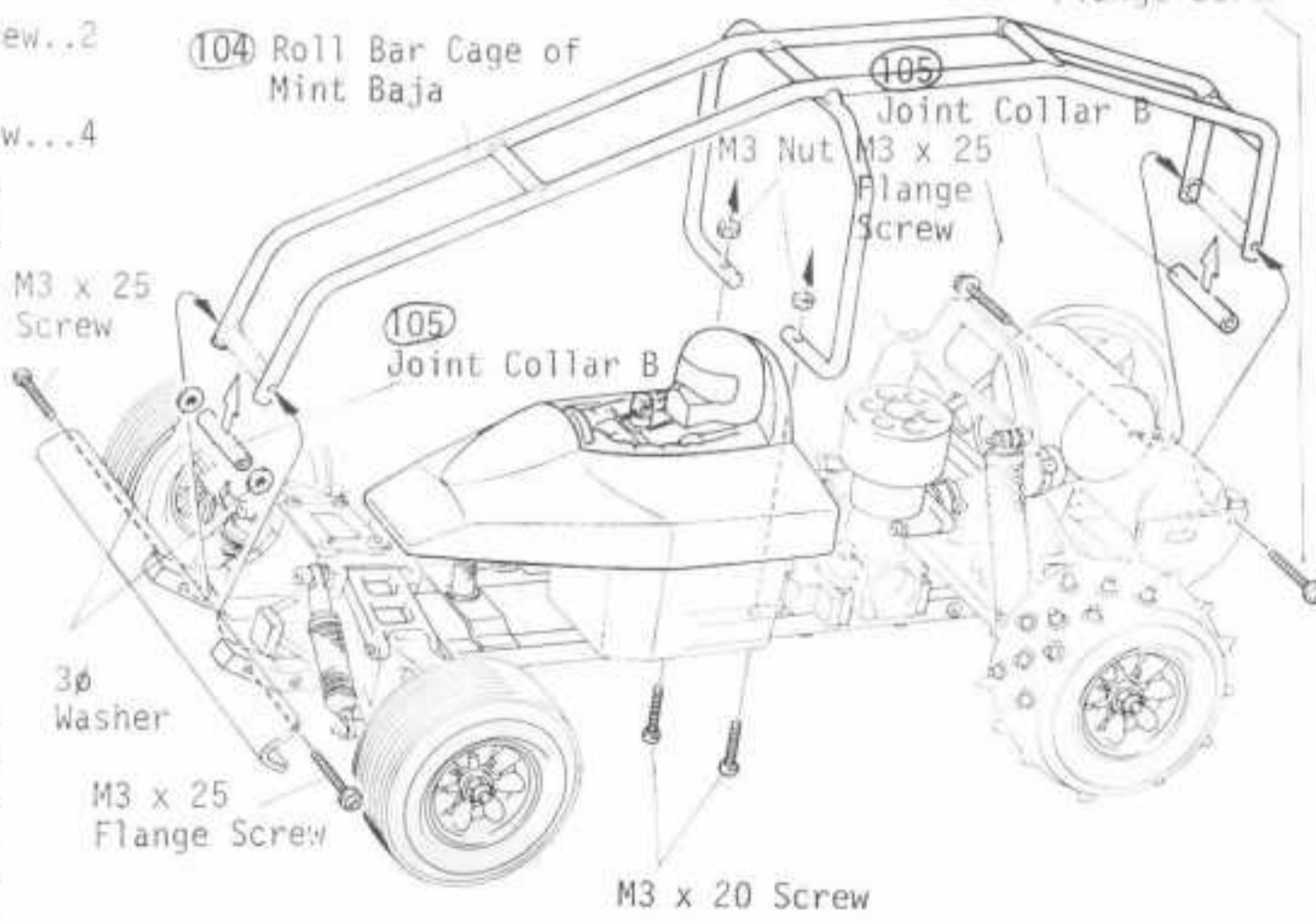

100 Fastening Knob

103 Driver

Do not use a nut



HOW TO START ENGINE

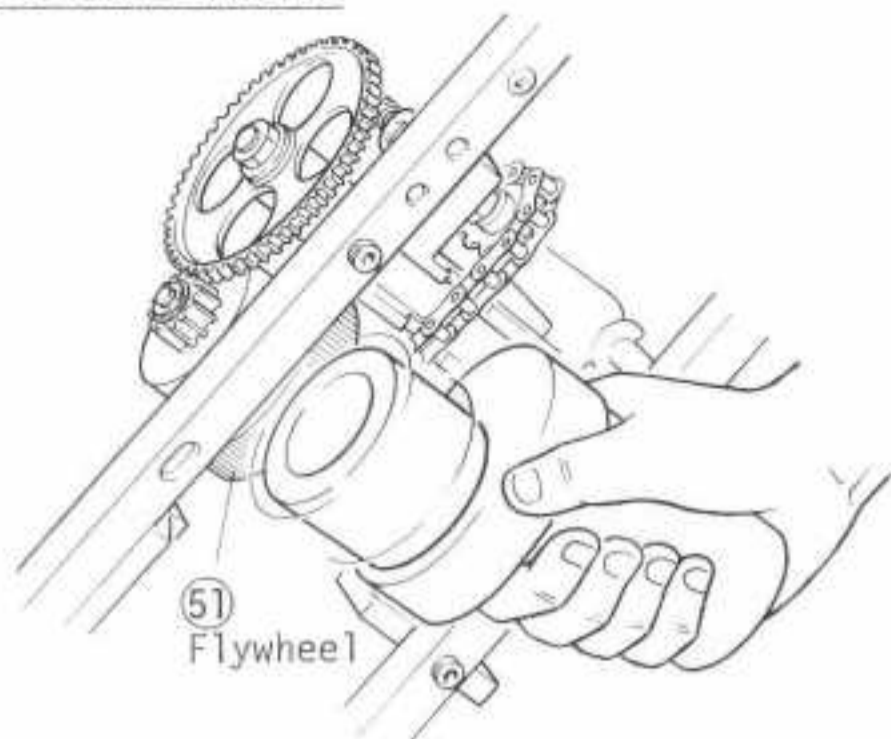

The engine of the Circuit 2000 cars is started by using an electric starter fitted with a rubber "donut". Pressing the starter up against the flywheel (from the bottom of the car) causes the motor to spin (don't forget to hook up the glow plug to a power source). It may take you a few times to get the "hang" of this, but keep trying. After a short time, you'll be able to start the car on the first try almost every time. The easiest way to stop the engine is to pinch the fuel tubing with your fingers until the engine runs out of gas.

ADJUSTMENT OF CAR CLEARANCE

[Adjustment of Front Axle]

[Adjustment of Suspension Arm] To be raised.

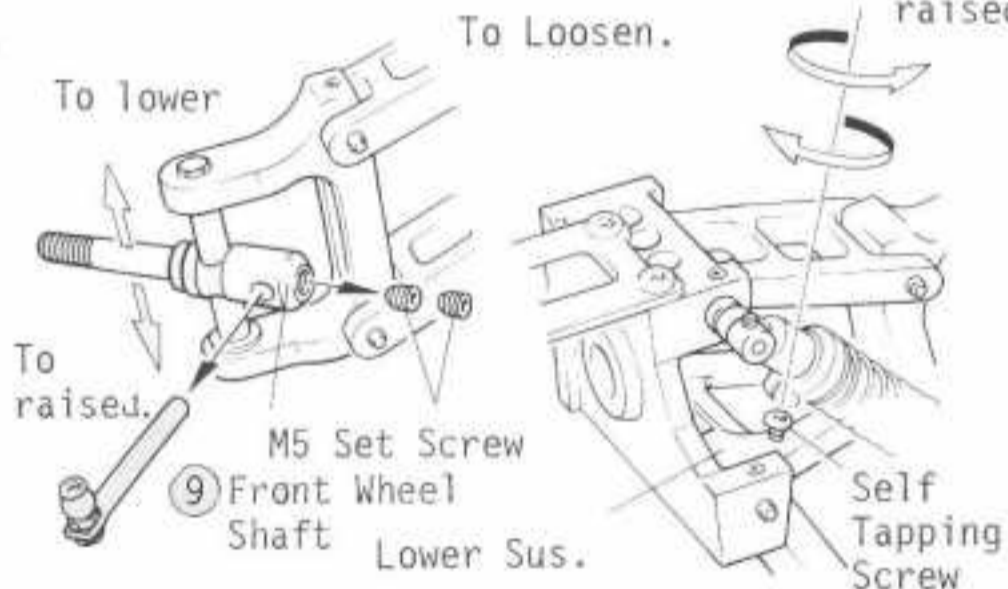

Remove the M5 setscrew which is holding the front axle 9 and move the axle up or down to adjust the car clearance. Be sure to have the same clearance on the right and left sides. You can also adjust the clearance with the suspension arm by turning the self tapping screw right or left.

CHECK UP OF CHAIN

66 Tensioner Shaft

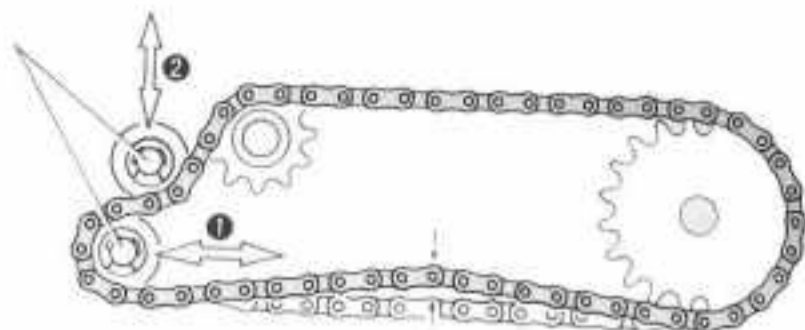

About 3 mm

The chain will stretch the first few times that you run the car. The slack can be adjusted by sliding the tensioner shaft (66) horizontally and vertically. When the chain is properly adjusted, it will have about 3mm of play.

ADJUSTMENT OF TOE-IN

about 1°

about 1°

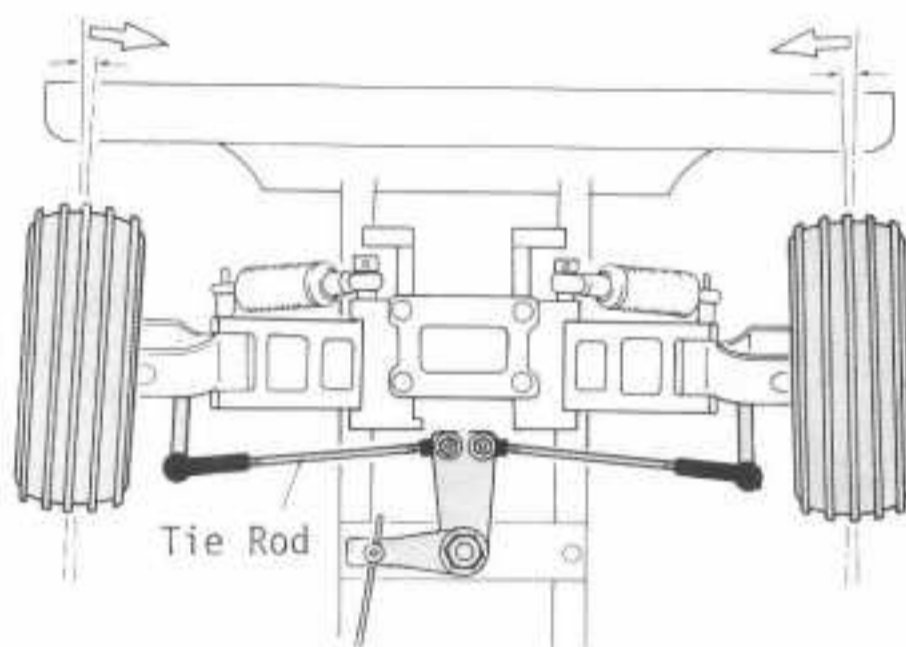

Toe-in is an adjustment of the front wheels that makes them converge slightly toward the front. This helps the model run in a straight line. Toe-in can be adjusted by changing the threaded tie rods. This model seems to run best with about 1 degree of toe-in on each side.

ADJUSTMENT OF AKKERMAN EFFECT

Hub Carrier Mount

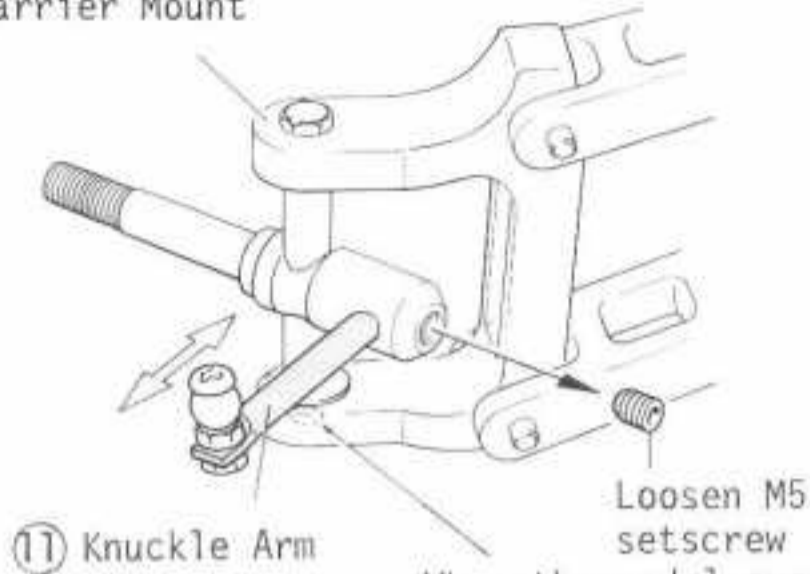

① Knuckle Arm

Loosen M5 setscrew

When the model oversteers, correct it by enlarging the hole for the kind pin on the hub carrier mount.

The Akkerman effect is a difference in the steering between the right and left wheels. This adjustment can be made by shifting the length of the knuckle arm; by making it shorter, the car will oversteer accordingly and by making it longer the car will understeer accordingly.

OPTIONAL PARTS

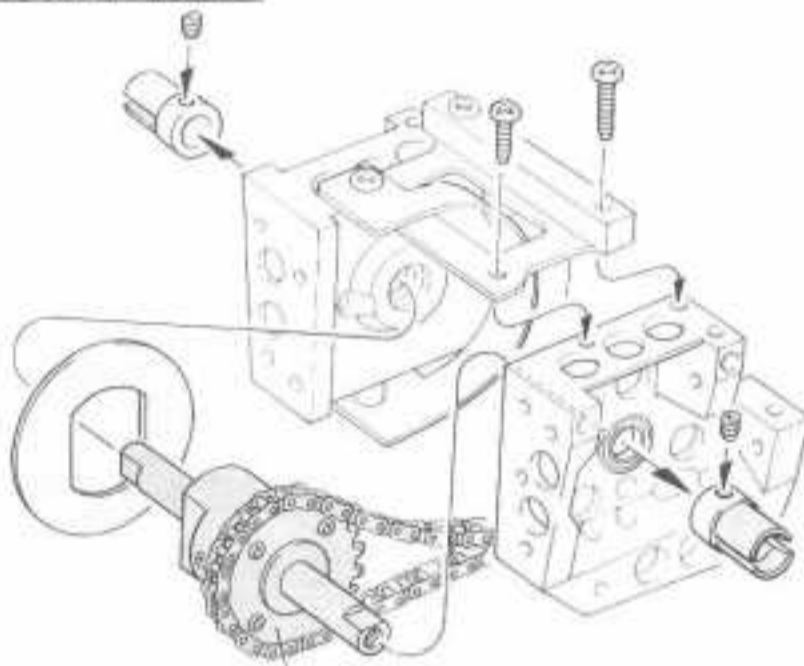

LD-79 Differential for Land Jump

With the LD-79 Rear Differential Gear for the Land Jump Kit, the handling is improved.



CB-110 Air Filter

[Using an Air Filter]

To keep the engine free from dust, use an air filter to the carburetor without fail. It is available as an optional part.

Clutch Bell	Spur Gear	Gear Ratio
12T (SD-53)	53T (LD-27)	10.6 : 1
13T (SD-54)	52T (LD-26)	9.6 : 1
14T (SD-55)	51T (LD-25)	8.7 : 1

The above combination is the only way possible to mesh the spur gear with the clutch bell.

⑥ Clutch bell.

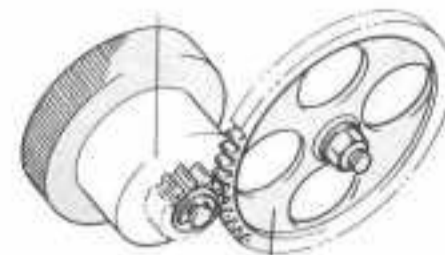

⑫ Spur Gear

[Changing Gear Ratios]

The 13 tooth clutch bell (61) and 52 tooth spur gear (122) are included with the kit and produce a gear ratio of 9.6:1. Optional gears will provide either 8.7:1 or 10.6:1 ratios. The 8.7:1 ratio will provide higher speed. The 10.6:1 ratio will improve handling and climbing.

OS-VFB Engine

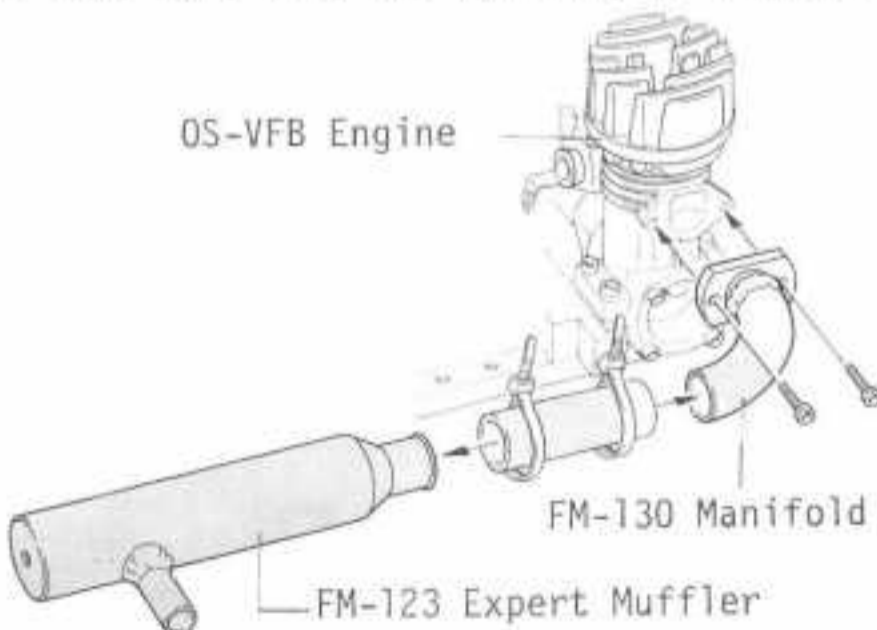

FM-130 Manifold

FM-123 Expert Muffler

With the OS Max -21 VF-B rear exhaust engine, use the manifold and muffler combination shown, above.

CAUTION

This car uses a chain and gearing for the drive system that moves at a very high speed and can be dangerous if not handled properly. NEVER touch the chain or gears while the engine is running (even if the drive parts are not turning).

Always make adjustments to the engine (needle valve, etc.) while the engine is at idle. Hold the rear wheels firmly (or have a friend do it for you) so that if they start to move, the car won't get away from you or get tangled in your cords or clothing. After making the adjustments, put the car down and DRIVE it to see if the adjustment is correct.

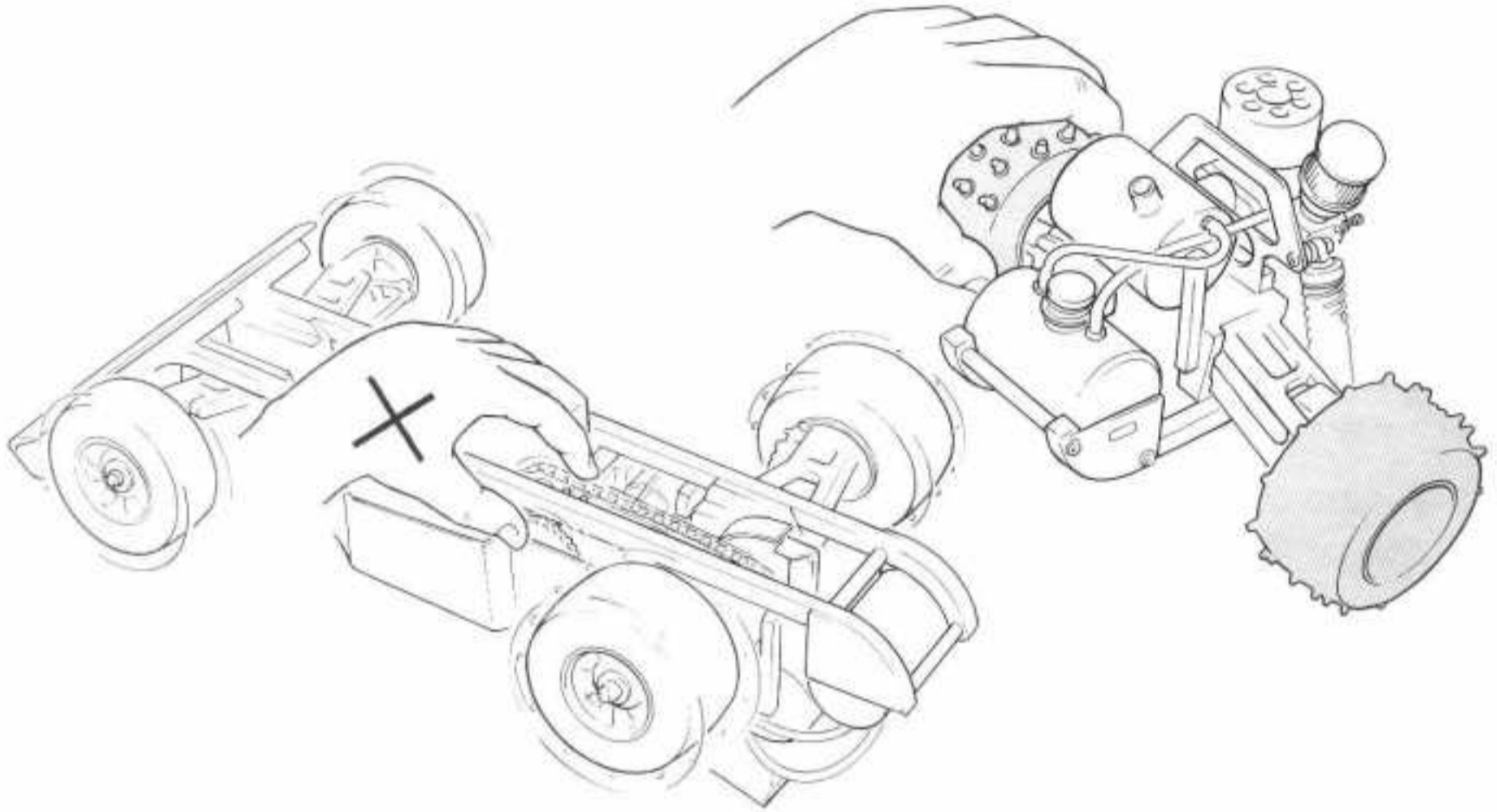

Never allow children to be in the immediate area that you are running your car. Kids love to chase RC cars (which is usually not too dangerous with the small electric types), BUT the Circuit 2000 is a high performance vehicle capable of much damage and pain if it runs into someone.

*If the car overturns, do not touch the chain or gears. Try to pick it up by the front bumper.

PARTS LIST

No.	Parts Name	Qty	No.	Parts Name	Qty
1	Main Chassis	2	59	Clutch Bearing	1 set
2	Servo Saver Mount	1	60	Lining	1
3	Servo Saver	1	61	Clutch Bell (13Z)	1
4	Servo Saver Shaft	1	62	E-ring (E-3)	1
5	Ball Collar	2	63	Adjust Spring	1
6	Steering Linkage Guide	1	64	Nylon Washer	1
7	Stay for Tank Installation	2	65	Spur Gear Shaft	1
8	Joint Collar		66	Tensioner Shaft	2
	For Impacta Baja	3	67	Tensioner Guide	2
	For Mint Baja	1	68	E-Ring (E-4)	2
9	Front Wheel Shaft	2	69	Linkage Guide	2
10	King Pin Shaft	2	70	Engine Control Servo Saver Shaft	1
11	Knuckle Arm	2	71	Engine Control Servo Saver	1
12	Hub Carrier Mount (R)	1	72	Servo Plate	1
13	" (L)	1	73	Servo Plate Collar	2
14	King Pin	4	74	2 ϕ Stopper	5
15	Ball	8	75	Rod Boots	2 set
16	Bulk Head (R)	2	76	Linkage Rod (A)	2
17	" (L)	2	77	" (B)	1
18	Front Lower Arm	2	78	Linkage Spring	1
19	Front Upper Arm	2	79	Mechanism Box	1
20	Lower Arm Shaft (A)	4	80	Linkage Rod (C)	1
21	" (B)	4	81	Switch Boots	1
22	Upper Arm Shaft (A)	4	82	Switch Plate	1
23	" (B)	2	83	Pressure Nipple	1
24	Bushing for Damper Installation	4	84	Muffler (A)	1
25	3 ϕ stopper	2	85	Muffler (B)	1
26	Bulk Head Plate	2	86	Baffle	1
27	Damper Oil	1	87	Muffler Shaft	1
28	Ball End (S)	6	88	Muffler Pipe	1
29	" (L)	2	89	Strap	2
30	Tie Rod	2	90	Muffler Adapter	1
31	Rear Axle Bearing	2 set	91	Antenna Pipe	1
32	Damper Stay (A)	1	92	Bumper	1
33	Brake Cover	1	93	Reinforcement Plate for Bumper	1
34	Center Shaft	1	94	Front Tire	2
35	Disk Plate	1	95	Rear Tire	2
36	Brake Arm	1	96	Front Wheel	2
37	Brake Pad (A)	1	97	Rear Wheel	2
38	" (B)	1	98	Drive Washer	2
39	Brake Caliper	1	99	Body for Impacta	1
40	Brake Shaft	1	100	Installation Knob	1
41	Muffler Stay	1	101	Mechanism Box Cover	1
42	Joint	2	102	Mechanism Box Seal	1
43	Rear Upper Shaft	2	103	Doll (Mint	1
44	Damper Stay (B)	1	104	Body for Mint	1
45	Damper Collar	7	105	Joint Collar (D)	2
46	Rear Wheel Shaft	2	106	Rear Damper	2
47	Rear Bearing	2	107	Rear Suspension Spring Stay	2
48	Swing Shaft	2	108	Rear Spring	2
49	Clutch Pin (S) for OS	2	109	Spring Holder	2
50	" (L) for Enya & Irvine	2	110	Front Damper	2
51	Flywheel	1	111	Front Suspension Spring Stopper	2
52	" Spacer	2	112	Front Spring Holder	2
53	Clutch Sheet	1	113	Spur Gear Mount	1
54	Pilot Shaft	1	114	Spur Gear Metal	2
55	Engine Mount (A)	1	115	Fuel Tank	1
56	" (B)	1	116	Fuel Tank Pipe	2
57	Clutch Shoe	2	117	Fuel Tank Bushing	2
58	Clutch Spring	2	118	Fuel Tank Tube	1

119	Fuel Tank Cap	1
120	Rear Shaft Collar	2
121	Rear Sprocket	1
122	Spur Gear	1
123	Chain	1
124	Rear Upper Arm	2
125	Rear Lower Arm	2
126	Rear Hub	2
127	Front Wheel Metal	4
128	Decal	1
129	Front Spring	2

<u>No.</u>	<u>Description</u>	<u>Key No. & Consisting of</u>
LD- 1	Bumper	92 93 x 1
LD-20	Engine Mount	55 56 x 1
LD-22	Chain Tensioner	63 66 67 68 x 1
LD-24	Spur Gear Shaft	64 65 x 1
LD-26	Main Gear	122 x 1
LD-28	Muffler Set	83 84 85 86 87 90 x 1
LD-29	Silicon Tube	88 x 1
LD-32	Rear Sprocket	121 x 1
LD-35	Engine Control Servo Saver	70 71 x 1
LD-36	Tank	115 118 119 x 1, 116 117 x 2
LD-38	Mechanism Box Set	72 79 100 101 102 103 81 82 x 1, 73 75 x 2
LD-45	Linkage Set	6 77 78 80 x 1, 69 76 x 2, 74 x 1
LD-70	Clutch Bearing	59 x 1
LD-76	Damper Rubber Bush	24 x 10
CB-11	Swing Shaft	48 x 2
CB-15	Ball Bearing	47 x 2
CB-28	Clutch Parts	60 x 1, 49 57 58 x 2
CB-51	Center Shaft	34 x 1
CB-52	Joint	42 x 2
CB-67	Clutch Spring	58 x 4
CB-72	E-Ring (E-3)	62 x 4
CB-80	Front Wheel	96 x 2, 127 x 4
CB-81	Rear Wheel	97 98 x 2
CB-84	Ball Bearing	31 x 2 (Sealed Type)
CB-89	Oil Damper (R)	15 28 106 x 2
SD-76	Flywheel	51 x 1
SD-54	Clutch Bell (13Z)	61 x 1
SD-56	Lining	60 x 5
FM-20	Clutch Sheet	53 x 5
FM-73	Pilot Shaft	54 x 1
FM-28A	Flywheel Spacer	52 x 1
SC-85	Front Damper	15 28 110 111 112 129 x 2
EF-38	Strap (M)	89 x 6
KC- 1	Main Chassis	1 x 2
KC- 2	Plate Set	2 x 1, 7 26 x 2
KC- 3	Servo Saver	3 4 x 1
KC- 4	Front Wheel Shaft	9 x 2
KC- 5	Knuckle Arm Set	10 11 x 2
KC- 6	Hub Carrier Mount	12 13 x 1
KC- 7	King Pin	14 x 4
KC- 8	Bulk Head	16 17 x 1
KC- 9	Front Arm Set	18 19 x 1
KC-10	Rear Arm Set	124 125 126 x 1

KC-11	Arm Shaft Set	23 43 x 2, 20 21 22 x 4
KC-12	Tie Rod Set	28 29 30 x 2 , 15 x 4
KC-13	Damper Stay Set	32 41 44 x 1
KC-14	Rear Wheel Shaft	46 120 x 2
KC-15	Chain	123 x 1
KC-16	Spur Gear Mount	113 x 1, 114 x 2
KC-17	Collar Set	5 x 2, 45 x 7
KC-18	3ø Stopper	25 x 10
KC-19	Rear Spring Set	107 108 109 x 2
KC-20	E-Ring (E-4)	68 x 4
KC-21	Joint Collar (Impacta Baja)	8 x 3
KC-22	" (Mint Las Vegas)	8 x 1, 105 x 2
KC-23	Screw Set	
KC-24	Body (Impacta Baja)	99 x 1
KC-25	Body (Mint Las Vegas)	104 x 1
KC-26	Decal	128 x 1
KC-27	Brake Caliper Set	33 36 39 40 x 1
KC-28	Front Tire	94 x 2
KC-29	Rear Tire	95 x 2
KC-30	Stainless Disk Set	35 37 38 x 1

OPTIONAL PARTS

LD-27	Main Gear (53T)	Use with SD-53 (10.6:1)
LD-25	Main Gear (51T)	Use with SD-55 (8.7:1)
SD-53	Clutch Bell (12Z)	Use with LD-27
SD-55	Clutch Bell (14Z)	Use with LD-25
LD-71	Spur Gear Bearing	Exchange with Key No.114
LD-79	Rear Differential Gear	
CB-161	Quick Tank Cap	
CB-110	Air Cleaner	
1881	Hard Oil for Differential	
1880	Damper Oil	
LD-82	Engine Parts for OPS & Pico	Mount & Flywheel for OPS & Pico

<INSTALLATION OF CLUTCH PINS>

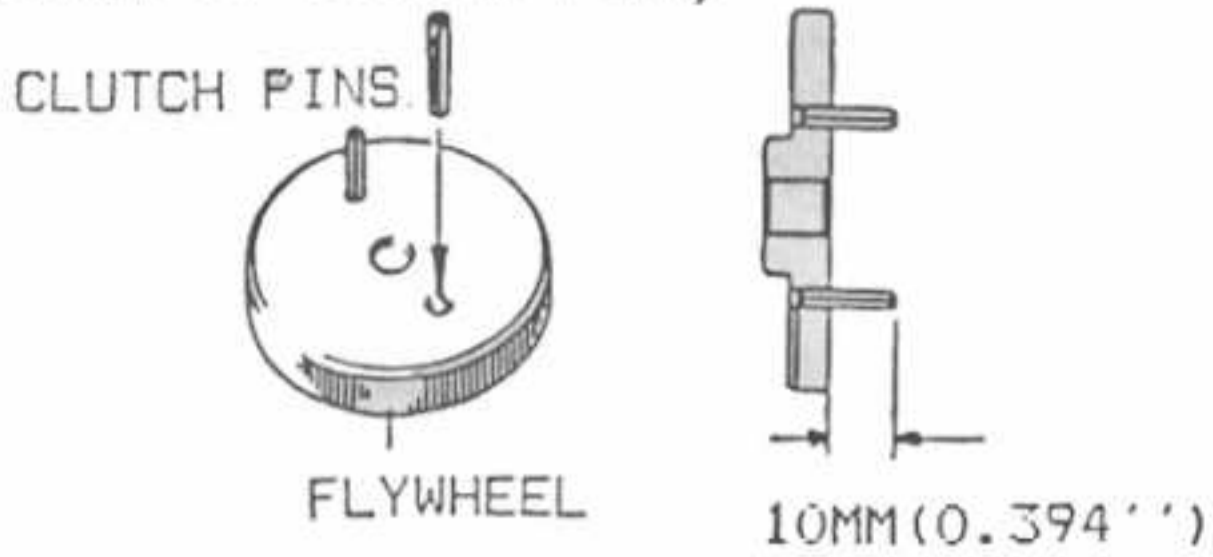

<INSTALLATION OF CLUTCH>

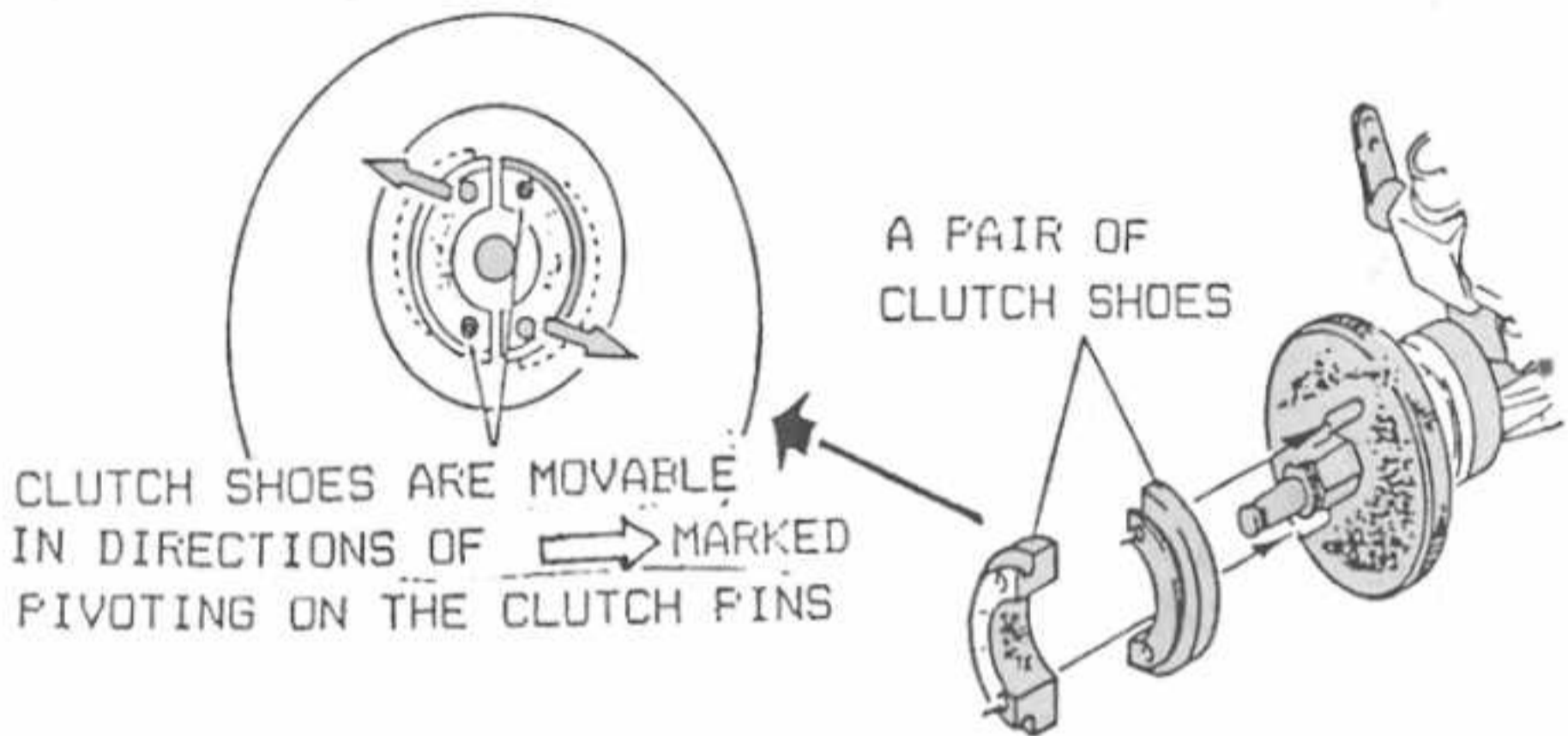

<INSTALLATION OF CLUTCH SPRING>

