

RADIO CONTROLLED ELECTRIC POWERED RACING BUGGY
OFF-ROAD RACER

ULTIMA

- SUPER LIGHT WEIGHT FOR SNAPPY ACCELERATION.
- SUPERB LONG-TRAVEL SUSPENSION FOR TOP HANDLING ON EVEN THE WORST TRACKS.
- NEW ALUMINUM PLATE/TRUSS CHANNEL-TYPE CHASSIS FOR STRENGTH AND LIGHT WEIGHT.
- OPTIMIZED COMBINATION OF SUSPENSION DESIGN AND WEIGHT DISTRIBUTION FOR TOP HANDLING.
- INDEPENDENT SUSPENSION ON ALL FOUR WHEELS BY PARALLEL WISHBONES/ARMS NEW RACE-TESTED GEOMETRY.
- COIL-SPRINGS AND OIL-FILLED SHOCK ABSORBERS ON ALL WHEELS.
- FRONT ANTI-ROLL BAR STANDARD. REAR BAR OPTIONAL.
- POWERFUL MABUCHI RS-540S MOTOR INCLUDED IN KIT.
- TRUE GEAR-TYPE DIFFERENTIAL.
- STRONG ALUMINUM AND NYLON PARTS. A QUALITY KIT.
- SIMPLE ADJUSTMENTS. DESIGNED FOR SIMPLE MAINTENANCE.
- MANY SUPER-PERFORMANCE PARTS AVAILABLE AS OPTIONS.

1:10 SCALE

BATTERY: 7.2V-1200mAh NiCd

RADIO: 2 channel
(NOT INCLUDED)



KYOSHO
THE FINEST RADIO CONTROL MODELS

◀ KIT No.3115 ▶

BEFORE ASSEMBLY

*Read the Instruction Carefully.

You can assemble the kit more easily if you have grasped the general idea of steps and structure beforehand by reading it through to the end.



Instruction

*Check the Parts in the Kit

Check to see if all the parts are correctly bagged as they are listed in the "List of Bagged Parts."



Your thorough understanding of the assembly will enable you to build the kit without difficulty. Check the components in the kit prior to your starting the assembly. Any claims for replacements or refunds for the model in the process of assembly will not be accepted.

*Learn the Marks described in the Instruction.



Points where grease should be applied. (It will reduce friction and assure smooth movement.)



Places to put some locktite. (It will prevent the screws and nuts get loosen by vibration while running.)



Steps where you particular attention is required.

*Be well aware of the Different types of screws.

Distinguish them by the pitch of thread and the shape of screw points.

Ordinary Screw



Finer Thread

TP Screw (Short form of self tapping screw)

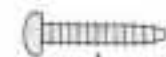

A tapered point

Coarse Thread

Set Screw



A hexagonal hollow in place of screw head.

Bind Screw



(There are two kinds of thread, finer and coarser ones.)

Thinner and bigger head

Truss Screw



Round and bigger head

Flat Head Screw



A shape of dish head

*Pick up the Correct Parts and Screw

List of Small Parts

Compare the shape and size of small parts, such as screws, nuts, and washers with the attached sheet of "List of Small Parts."



Check up small parts with the list.

*Be sure about the Location and Direction of Parts to Install.

Be careful about the direction.

Double-check the location and orientation of parts with the illustration before installation. When necessary, assemble the parts themselves tentatively before proceeding to the next step.

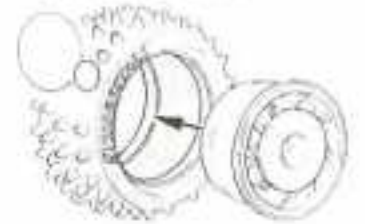

*Do not tight the Self-tapping Screw too tight.

Do not use excessive force when tightening the self-tapping screws, or you may strip the thread in the plastic. It is recommended to stop tightening it when the threaded part on the screw goes into the plastic part and you feel some resistance from the tightening.

Good

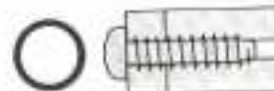

Over tighten and may strip the thread in the plastic.

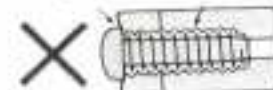

THINGS NEEDED BESIDES THE KIT

[2 Channel Radio System]

Two types of radio control sets are on the market, the stick type and the steering wheel type. Choose which ever you like.

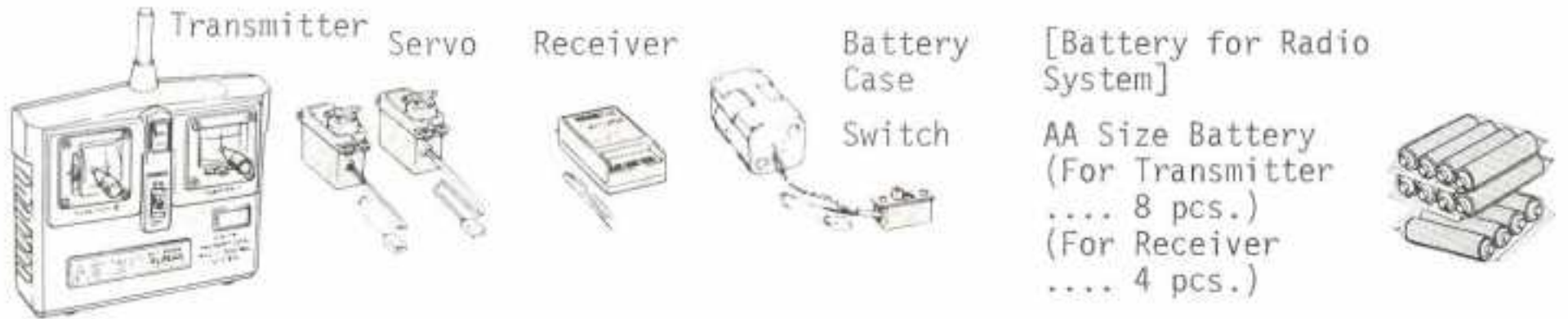

[Ni-Cad Battery]

"Ultima" is designed to use a rechargeable 7.2V 1200mAh Ni-Cad battery pack. A Kyosho Racing Battery, Part number 2213 (and some other brands) may be recharged at a wide range of rates. The charging rate depends on the type of charger used.



[Battery Charger]

The simplest charger supplies a low current, and the battery is charged for 14-16 hours. This type of charger operates on household AC power. Faster charges are available, all operated from a well-charged 12V car battery. Using these, the battery pack can be recharged in 15-20 minutes. With the two or three battery packs, it is possible to run the car almost continuously. Kyosho offers three types of fast charger. Type 2207 charges at a constant current for a time set by a timer. Type 1846 allows adjusting the current using a built-in ammeter, and a timer shuts off the current at the time set by the user. Type 1848 also allows adjusting the current with a built-in ammeter, but a circuit in it monitors the voltage of the cells and cuts off the charging current when the cells are fully charged. The latter two can charge a battery pack to 100% of its capacity, while the first gives about 70% of full charge safely.

Item No.	Name of Charger	Charging Time	Charging Rate	Features
No. 2221	Super Ni-Cad Charger (AC100V)	14 to 16 hrs.	100%	For beginners
No. 2207	Super Ni-Cad Rapid Charger (DC12V)	15 minutes	about 70%	For beginners; timer built in
No. 1846	Multi Charger (DC12V)	20 minutes	100%	Timer, Ammeter built in
No. 1845	Lambda Charger (DC12V)	about 20 minutes	100%	Ammeter, in; Automatic cut-off at peak of charge
No. 2232	Super Ni-Cad AC Rapid Charger	about 40 minutes	about 80%	Chargable from Household Outlet, Electronic Timer built in

The Ultima comes with a Mabuchi RS-540 motor as stock. You may wish to upgrade the performance by purchasing a Kyosho LeMans Motor.

[Required Tools]

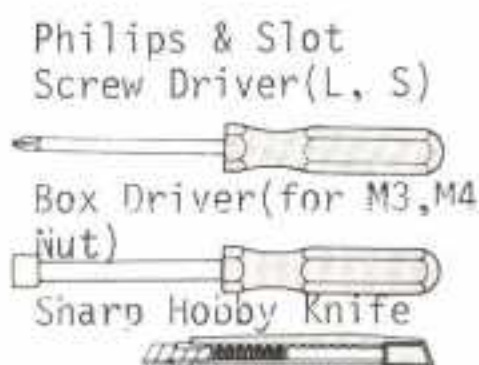

1 ASSEMBLY OF DIFFERENTIAL GEAR

⑧ Bushing Collar

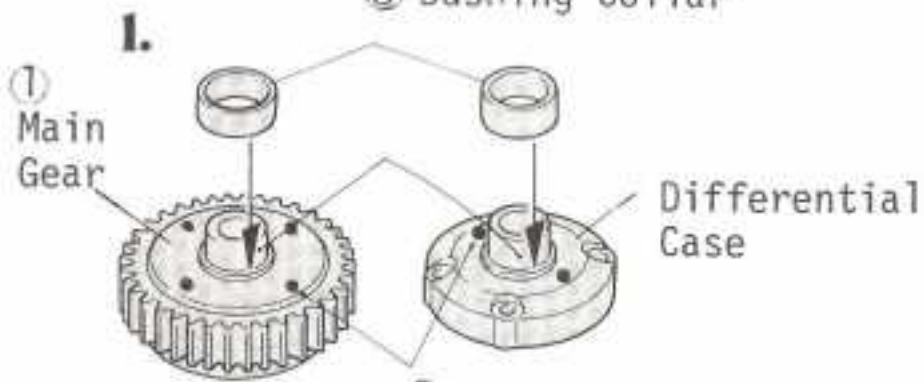

Boss

*Cut off six bosses and make the surface flat.

*In the case the optional ball bearings are employed as shown in step 2, do not fix the plain bearings.

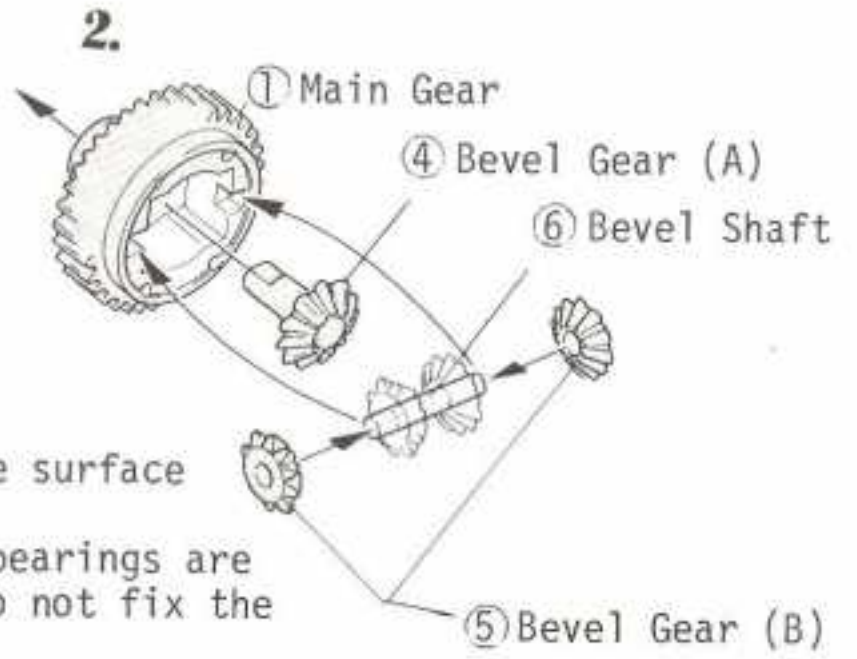

3.



Fill up the gear train space with silicone grease.

① Main Gear

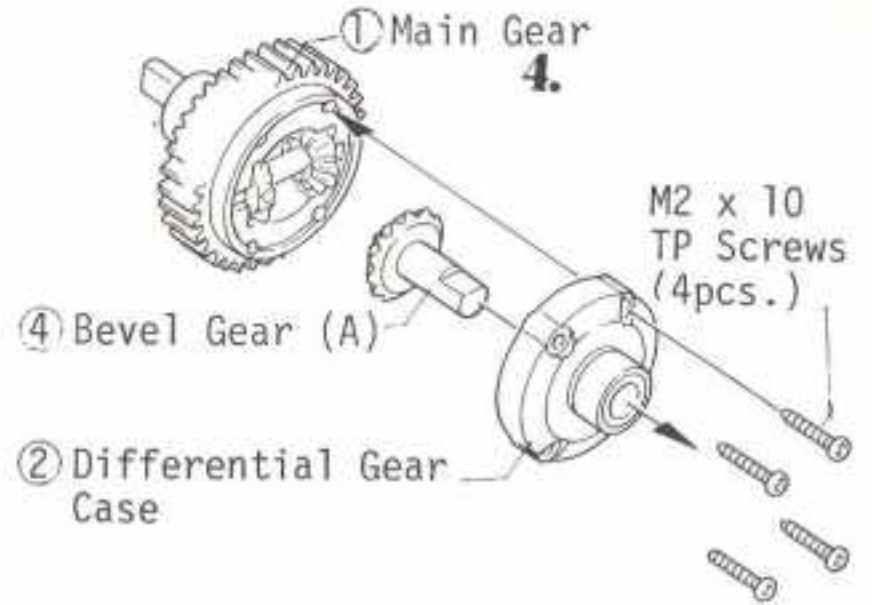

2 INSTALLATION OF JOINT

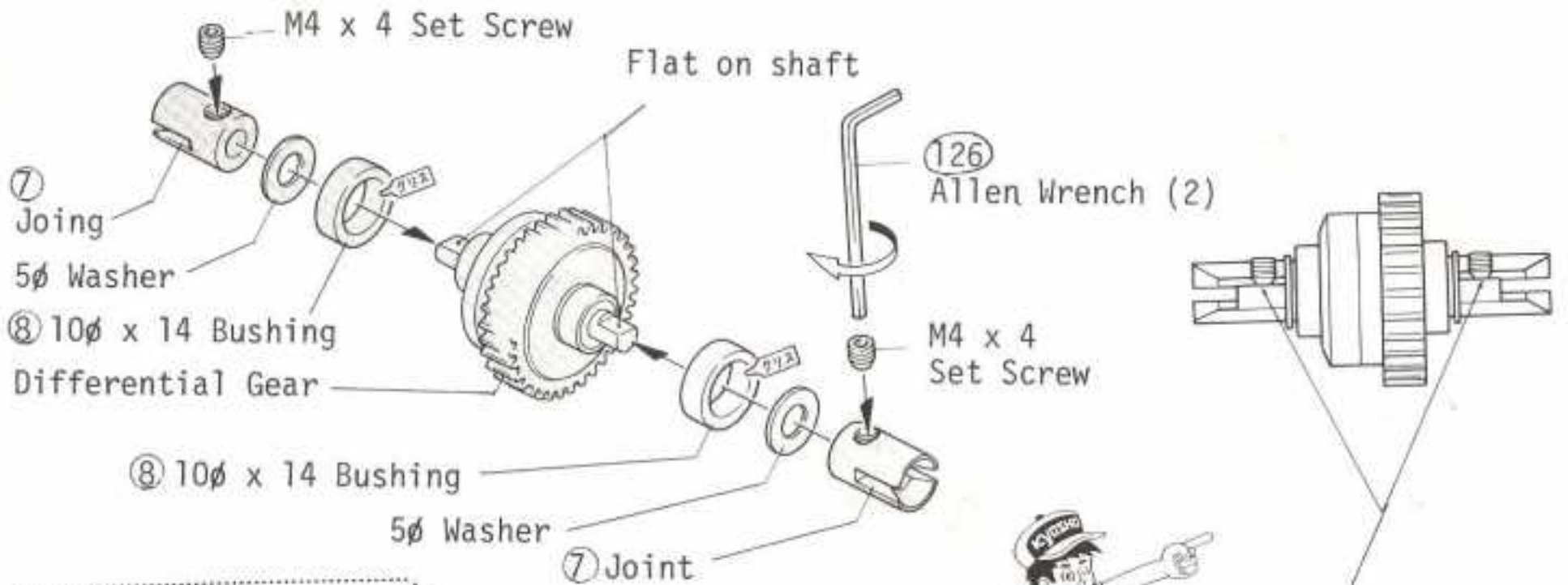

Set the set screw to the flat on the shaft and tight.

*The optional ball bearings are adopted here.

1911
8φ x 14
Ball Bearing

3 INSTALLATION OF COUNTER GEAR

*The optional ball bearings are adopted here.
In place of plain bearings, fit the 5mm dia. x 10 ball bearings, parts No.1901.

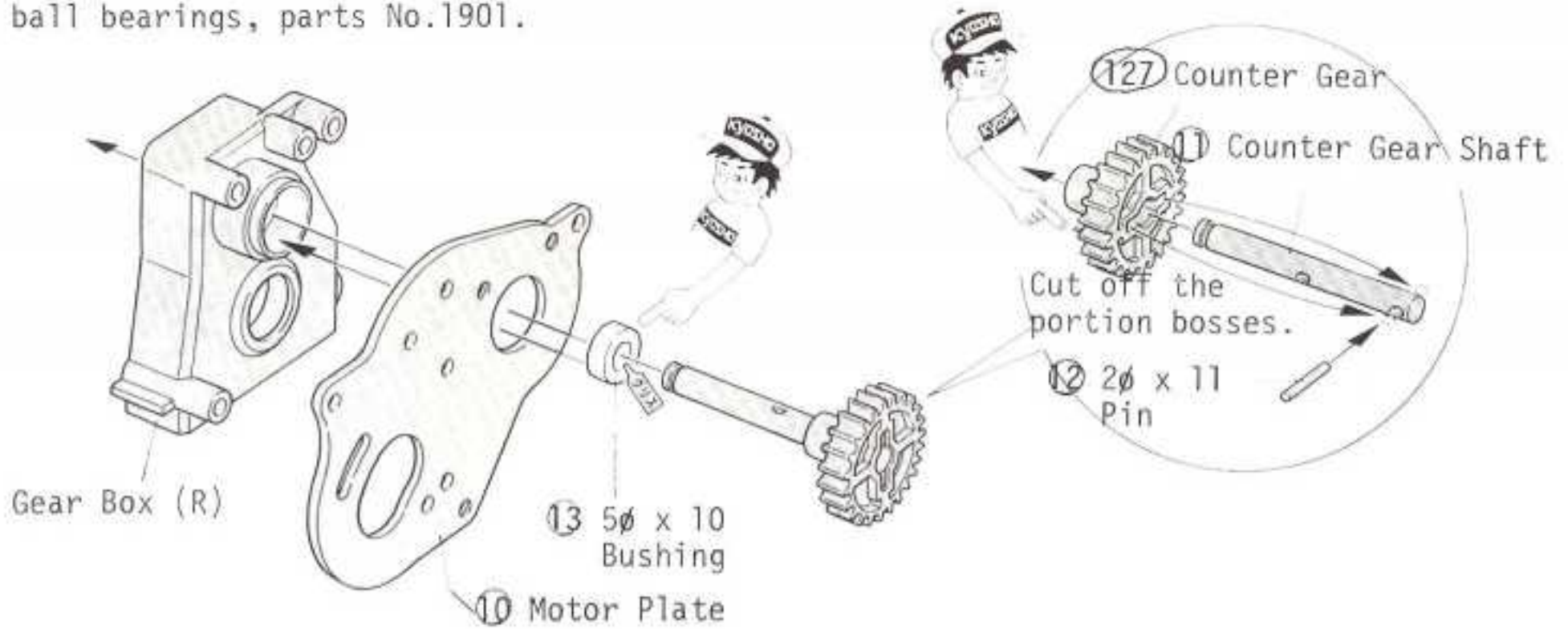

4 INSTALLATION OF FINAL PINION

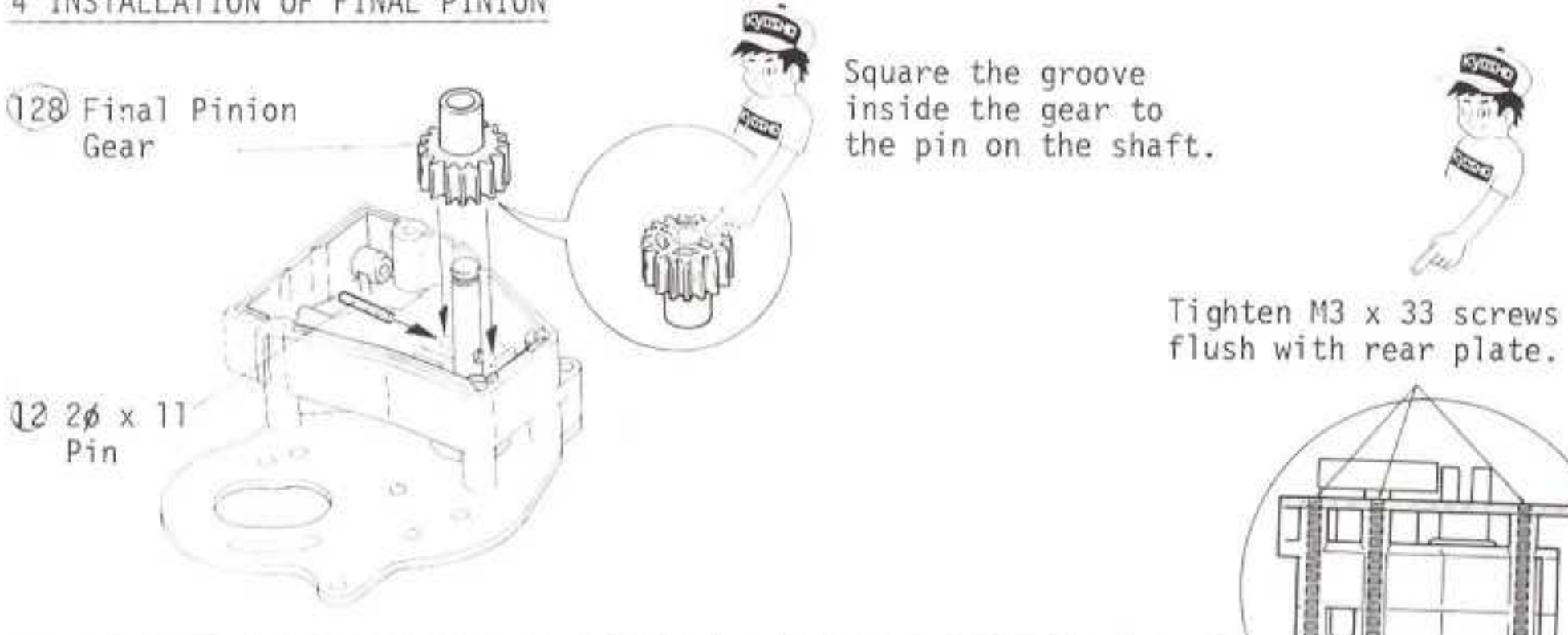

5 ASSEMBLY OF GEARBOX

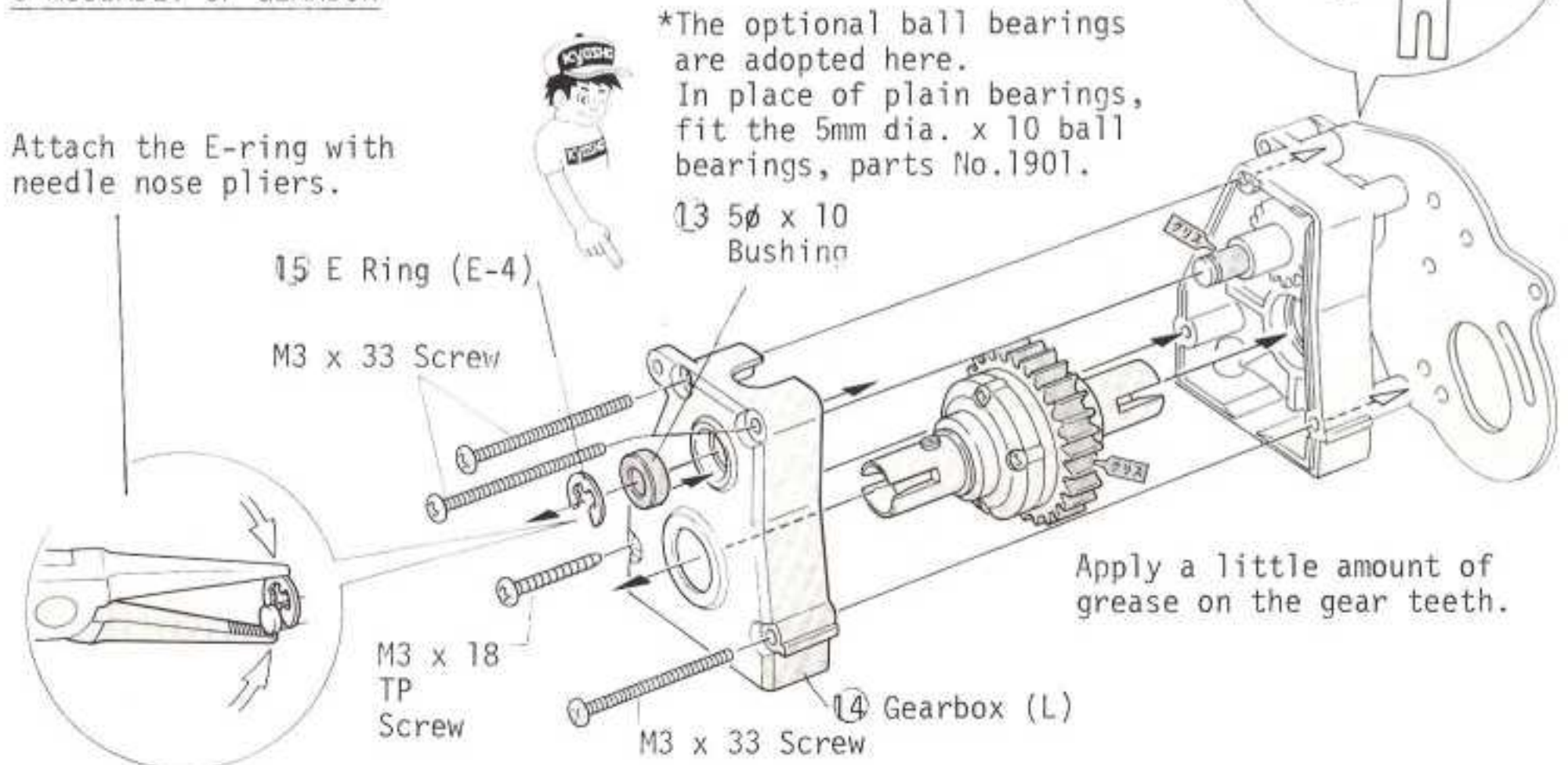

6 INSTALLATION OF REAR SHOCK STAY

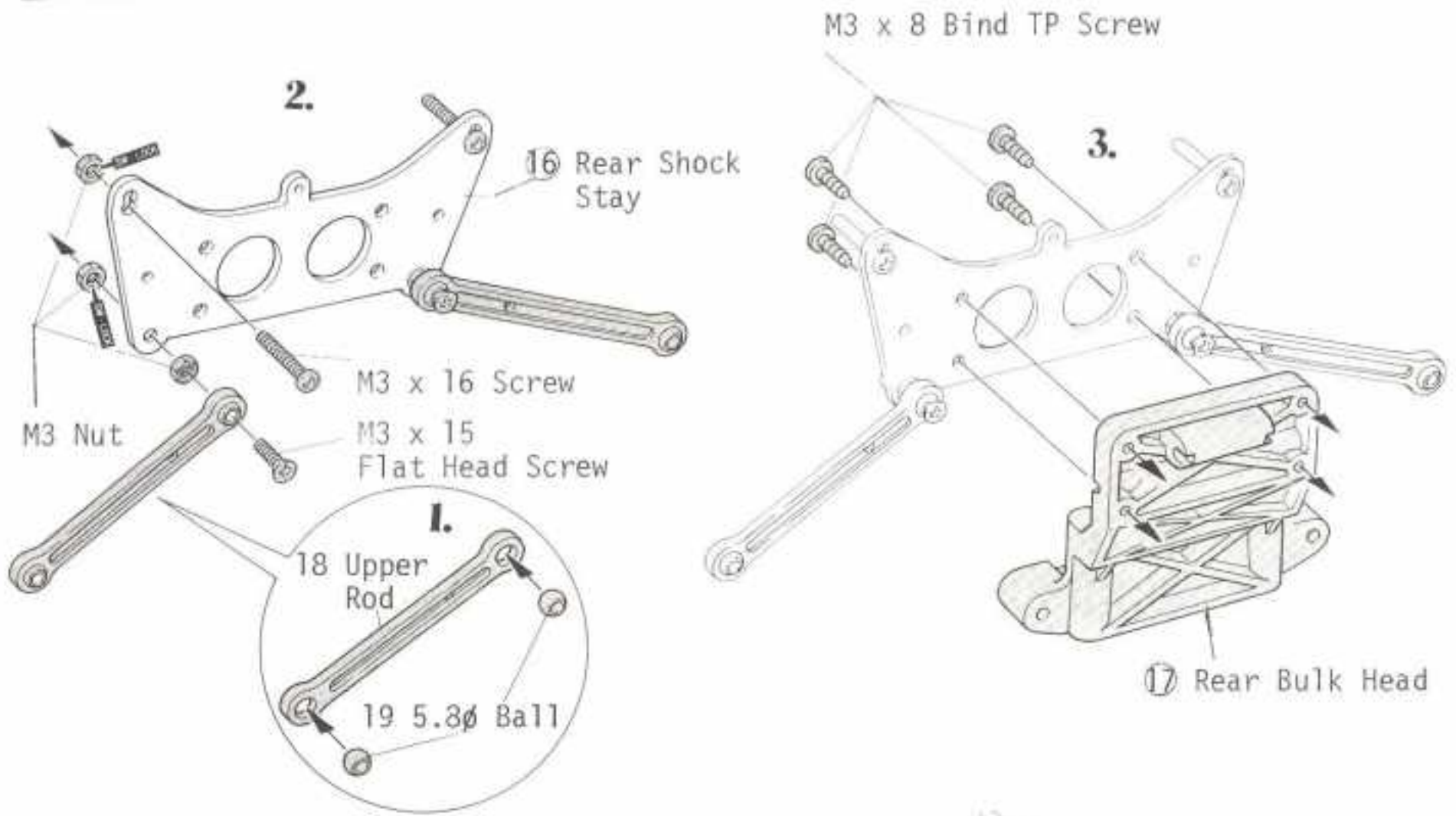

7 INSTALLATION OF GEARBOX

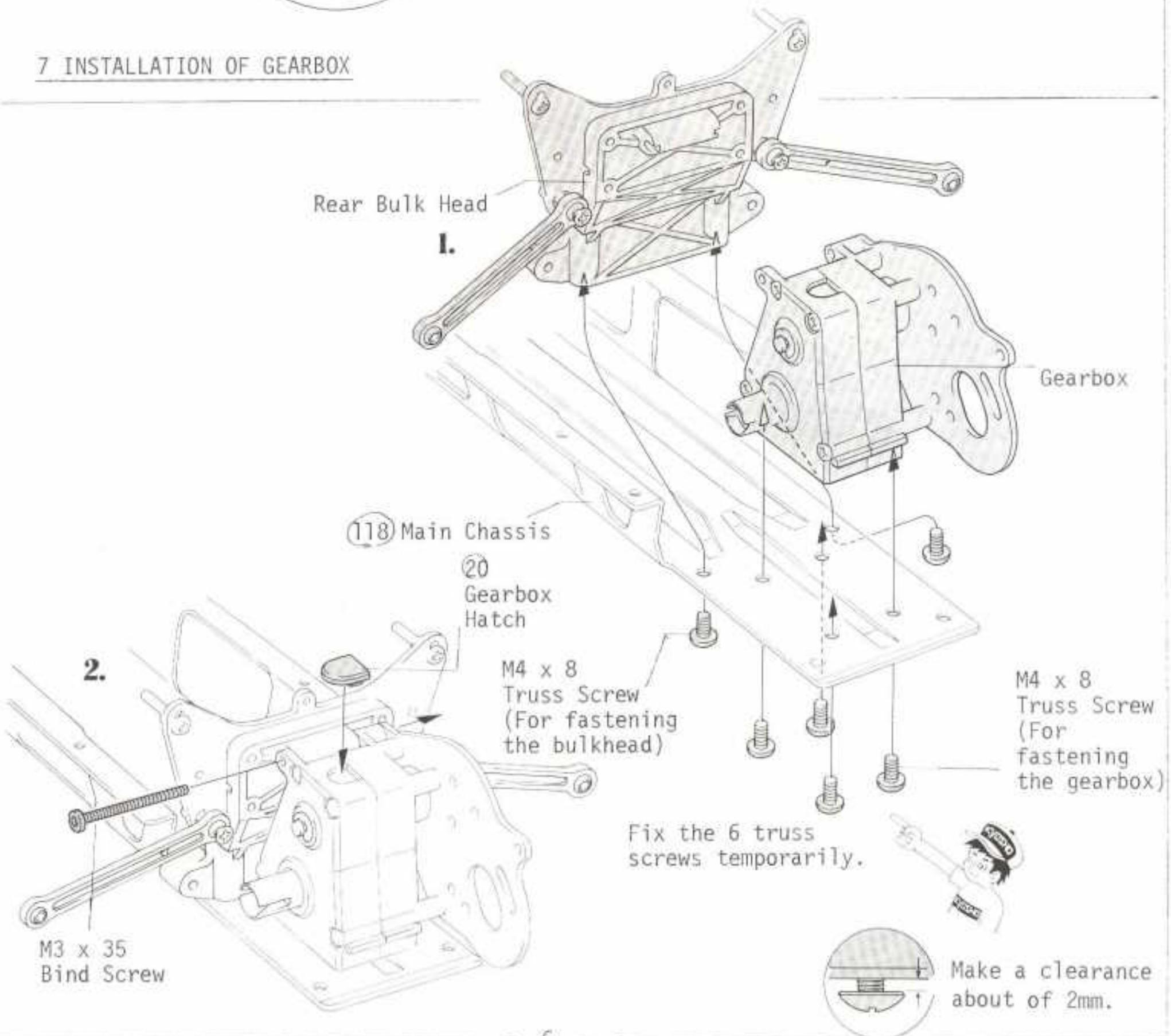

8 INSTALLATION OF REAR HUB

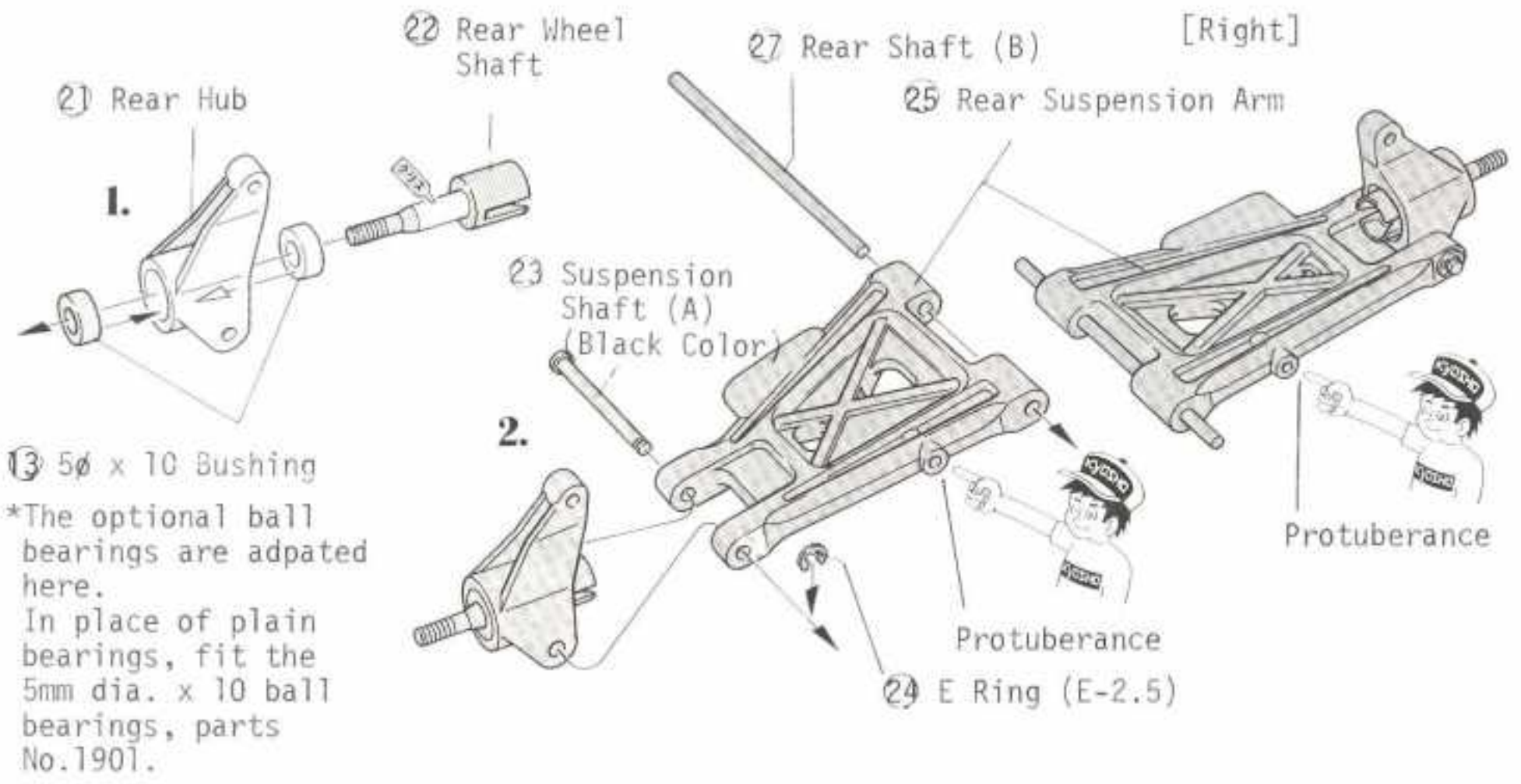

13 5φ x 10 Bushing

*The optional ball bearings are adapted here. In place of plain bearings, fit the 5mm dia. x 10 ball bearings, parts No.1901.

9 INSTALLATION OF REAR SUSPENSION

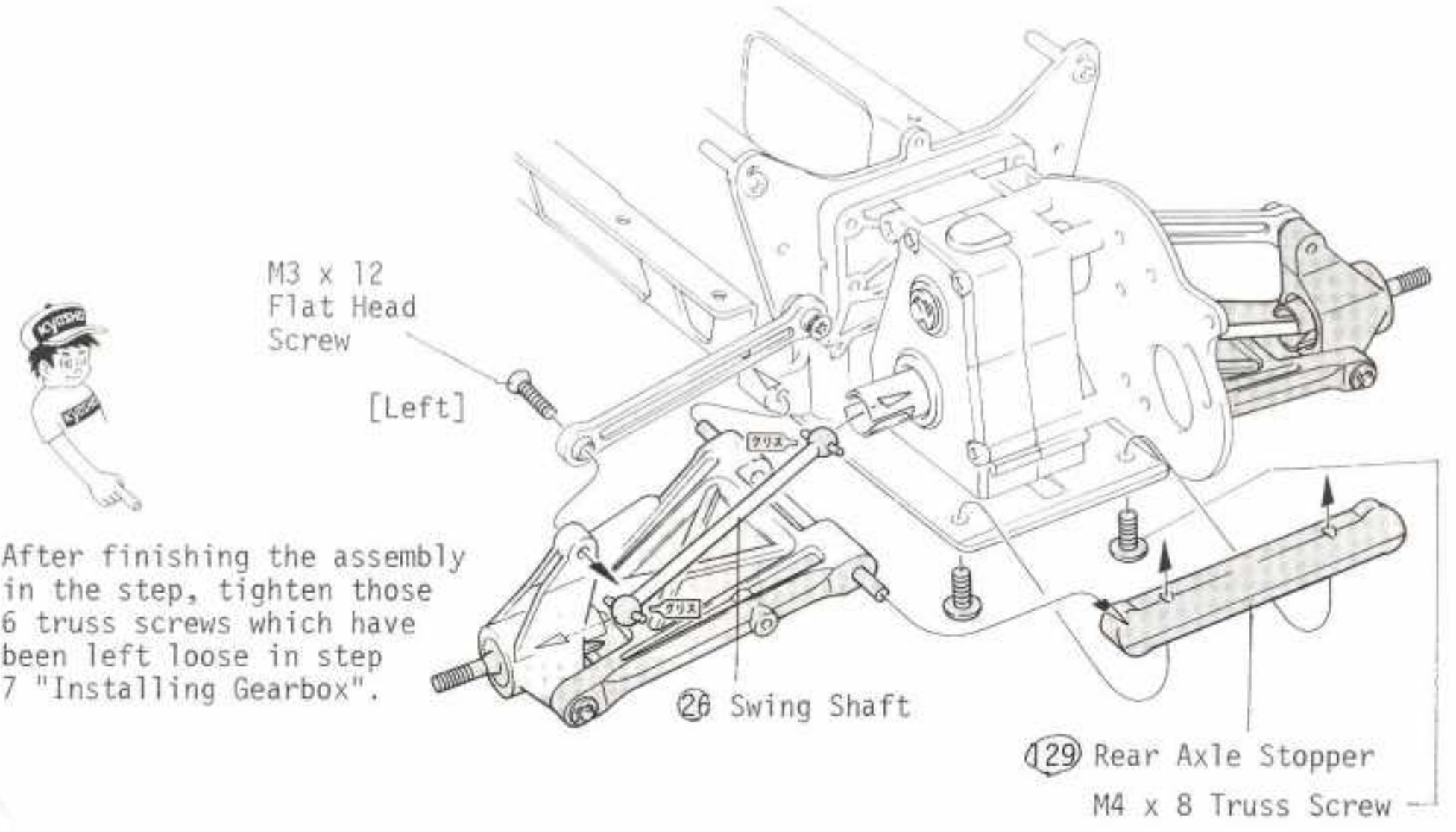

After finishing the assembly in the step, tighten those 6 truss screws which have been left loose in step 7 "Installing Gearbox".

10 FILLING SHOCK WITH OIL

[Disassembly of Shock]

Remove the spring receptacle and the spring, and other parts as shown in the drawing on page 24; and reassemble pursuant to the following processes 1 to 3 as illustrated below.

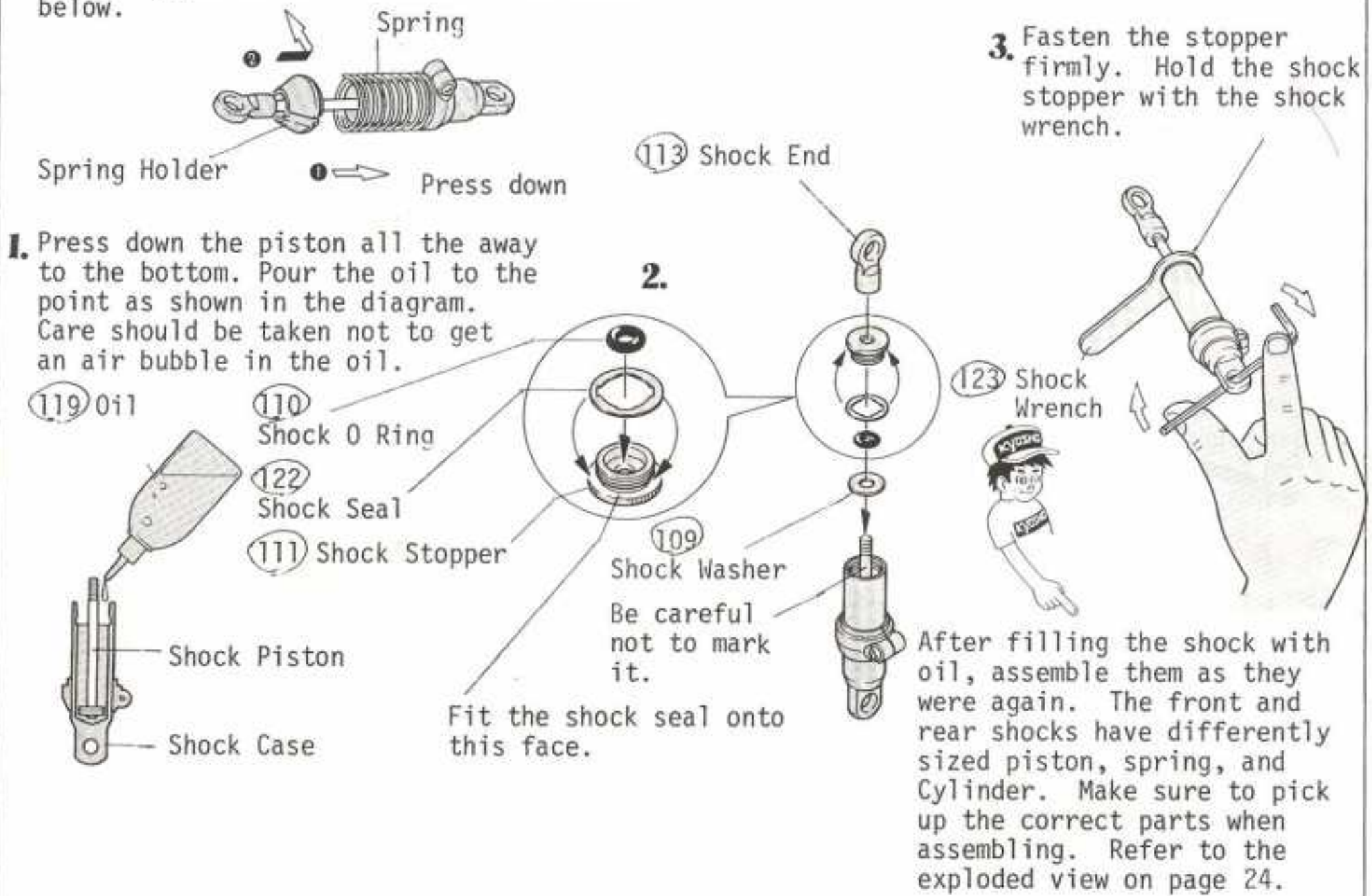

11 INSTALLATION OF REAR SHOCK

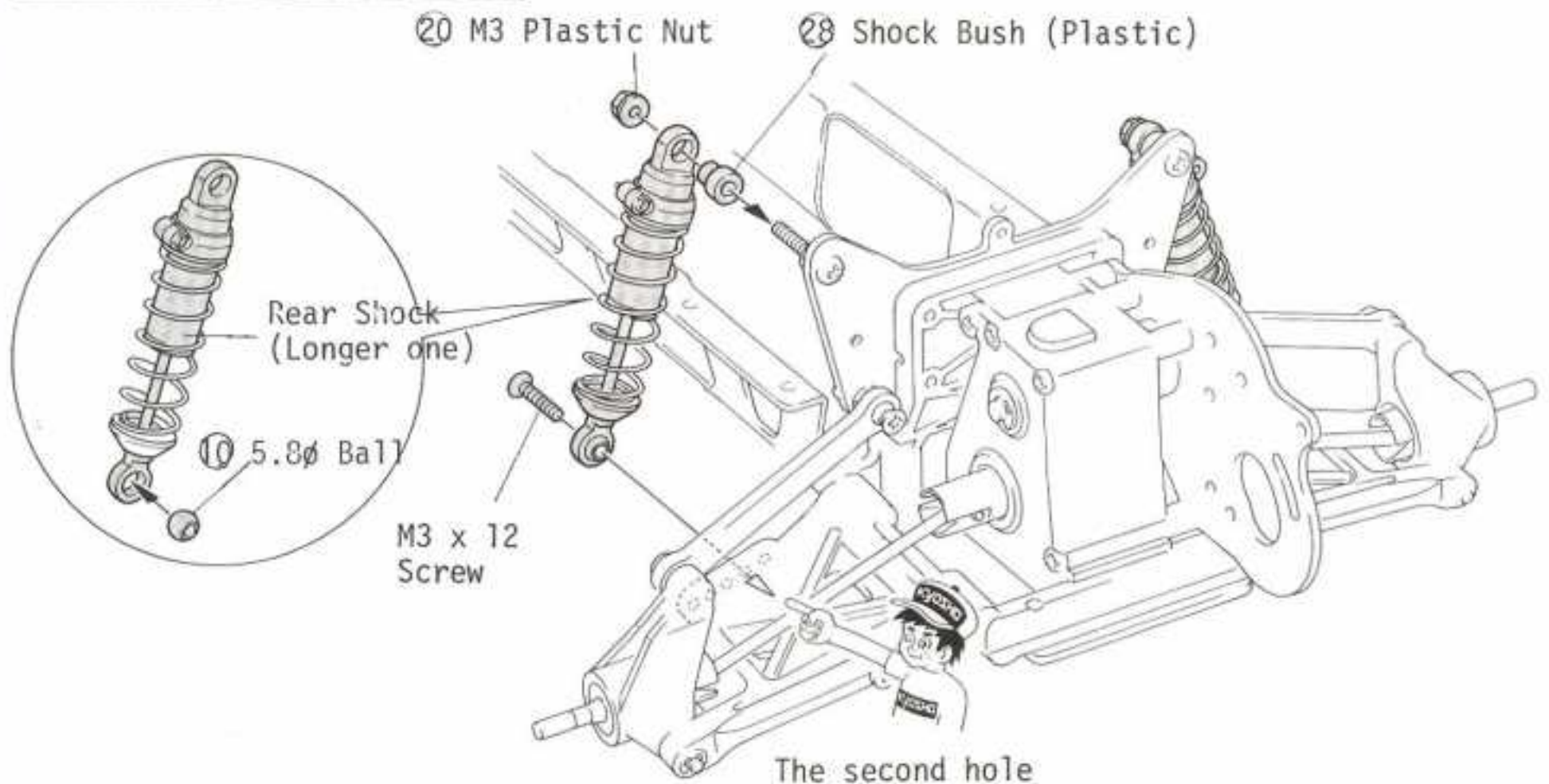

12 INSTALLATION OF FRONT KNUCKLE ARM

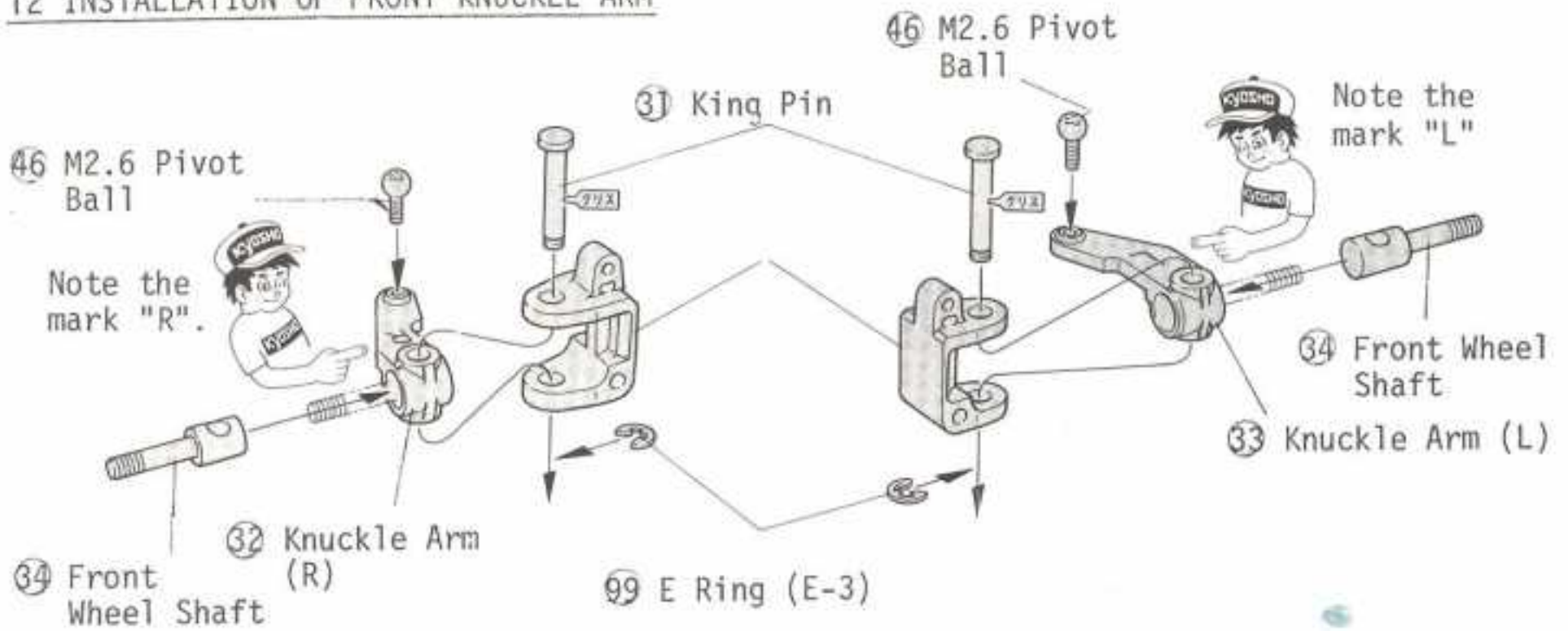

13 INSTALLATION OF FRONT SHOCK STAY

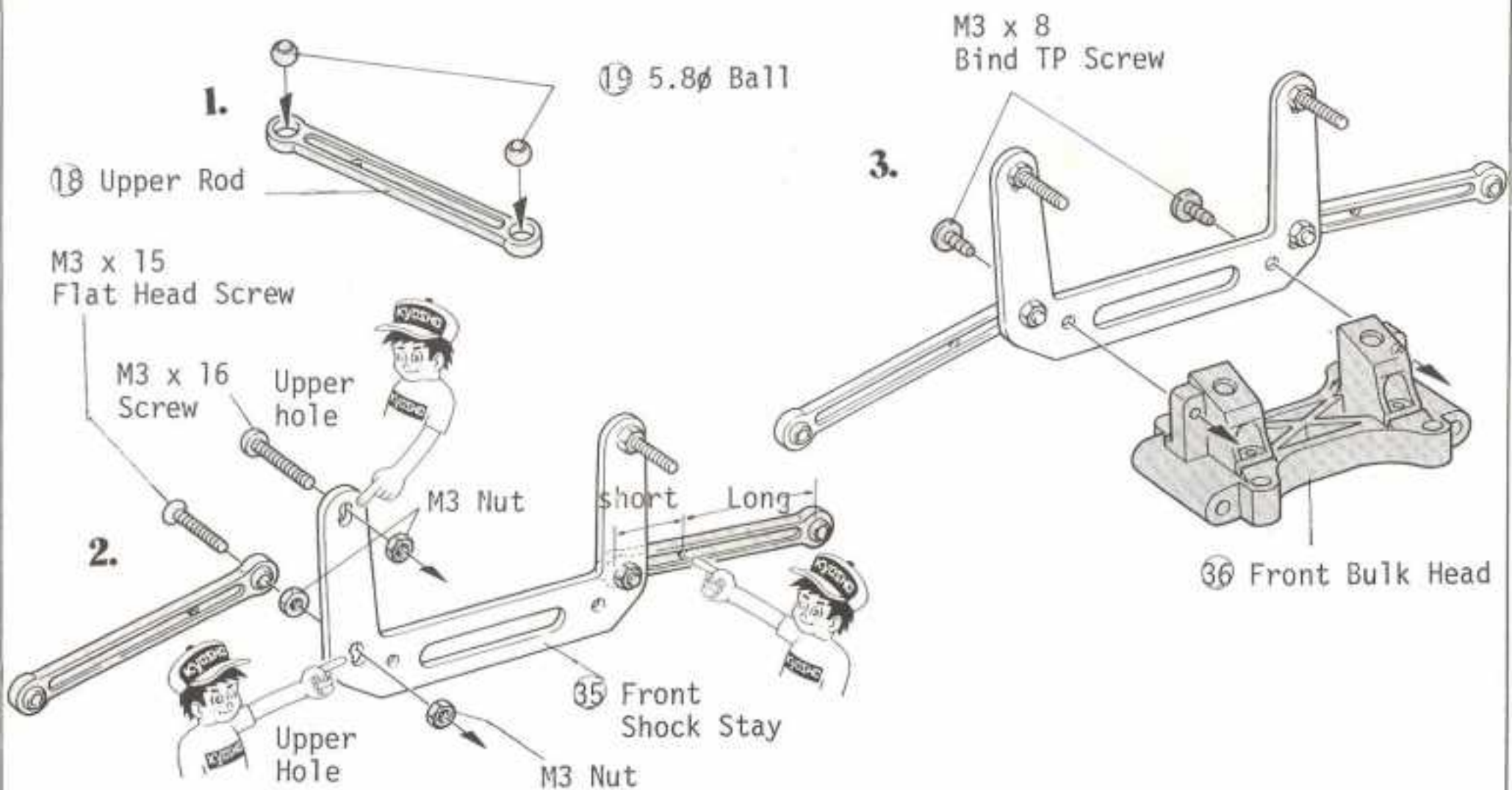

14 INSTALLATION OF FRONT SUSPENSION ARM

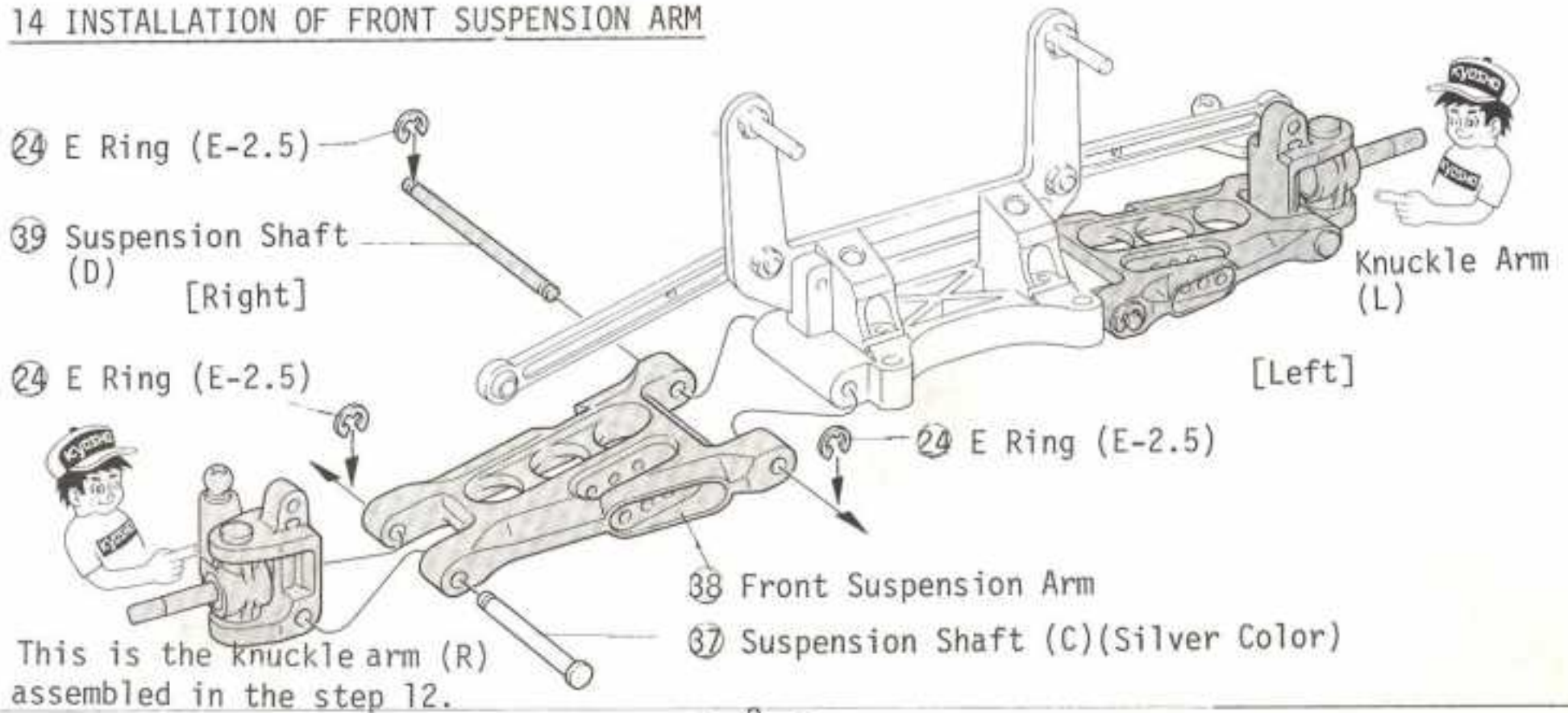

15 INSTALLATION OF FRONT BULK HEAD

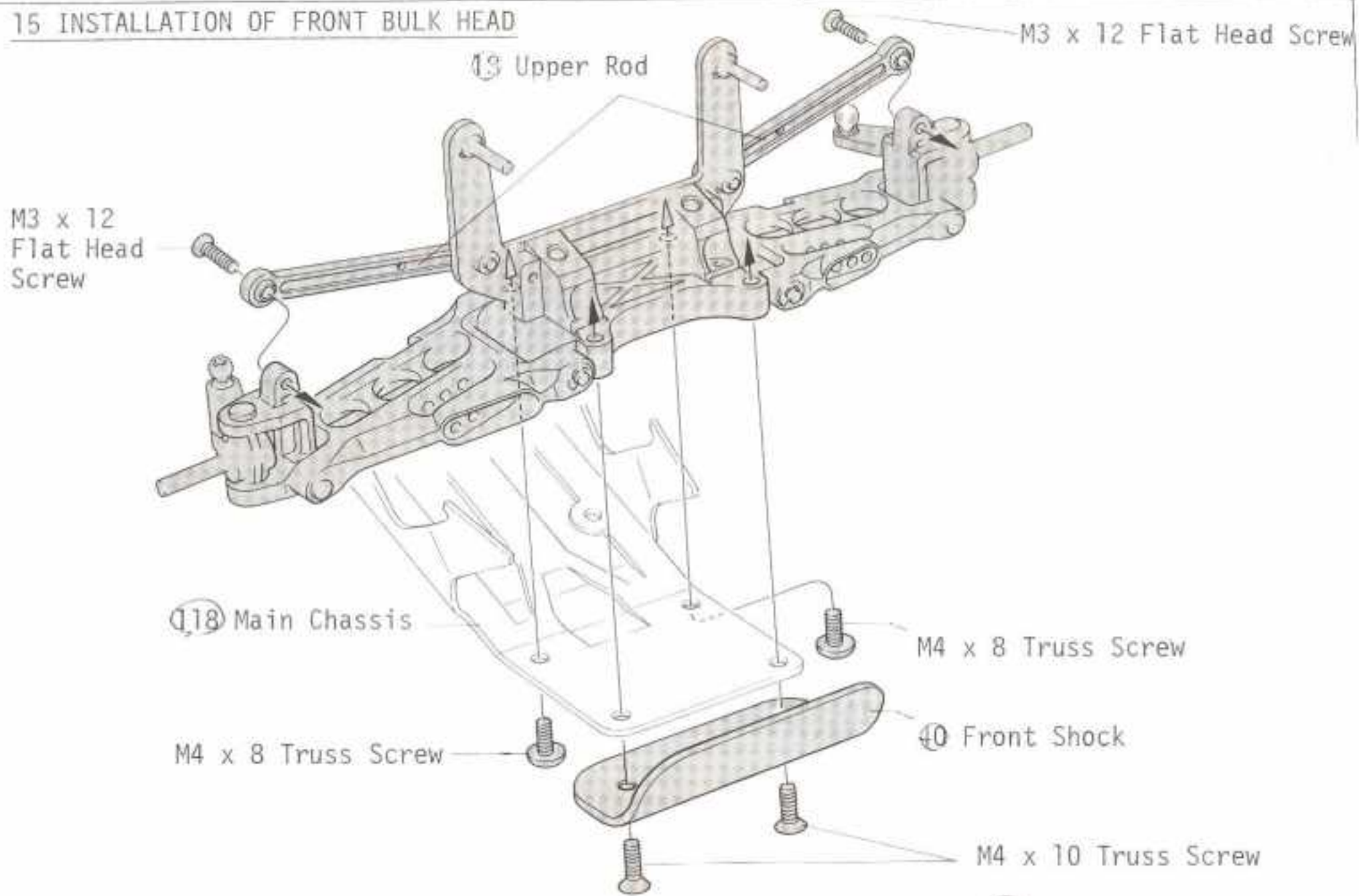

16 INSTALLATION OF FRONT SHOCK

Front Shock
(Shorter one)



28 Shock Bush
(Plastic)

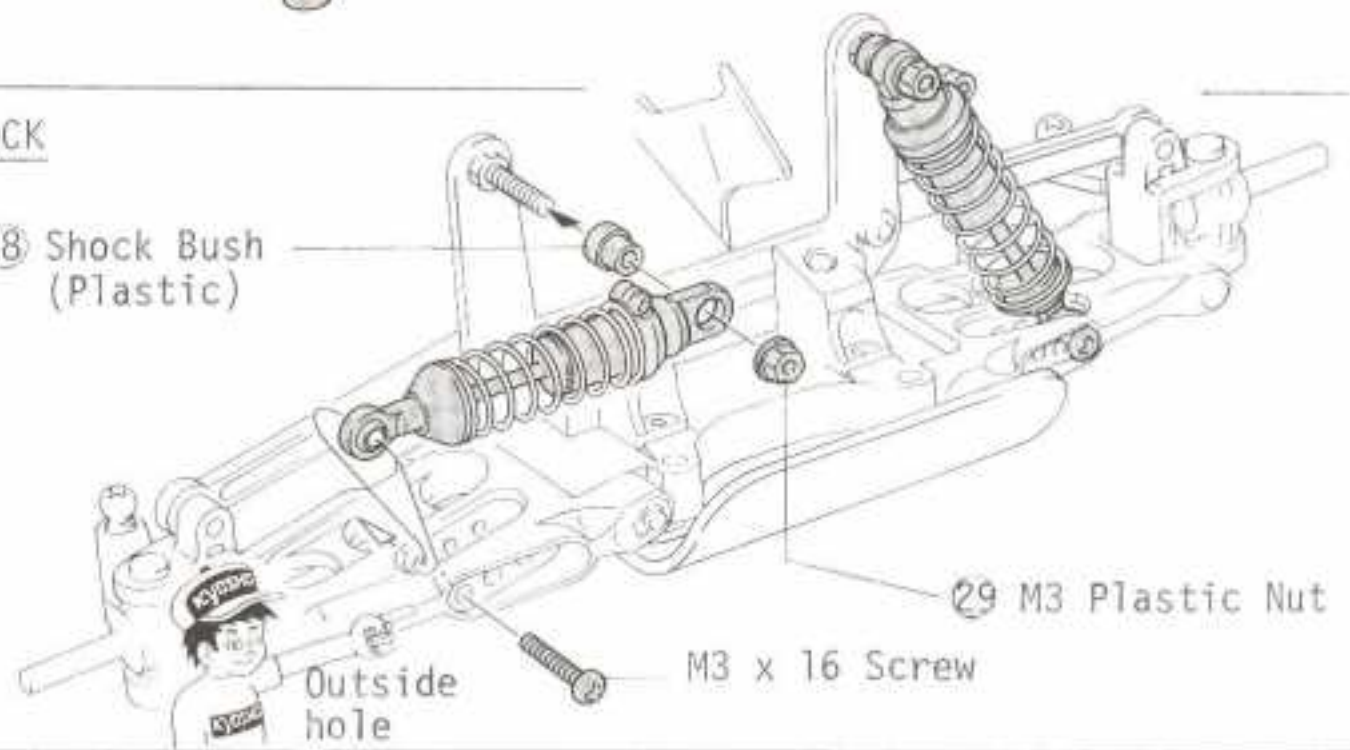

17 ASSEMBLY OF SERVO SAVER

41 Ball Nut

42 Servo Saver (A)

43 Servo Saver (B)

M2.6 x 6 Bind Screw

46 M2.6 Pivot Ball

45 Servo Saver (D)

M2.6 Nut

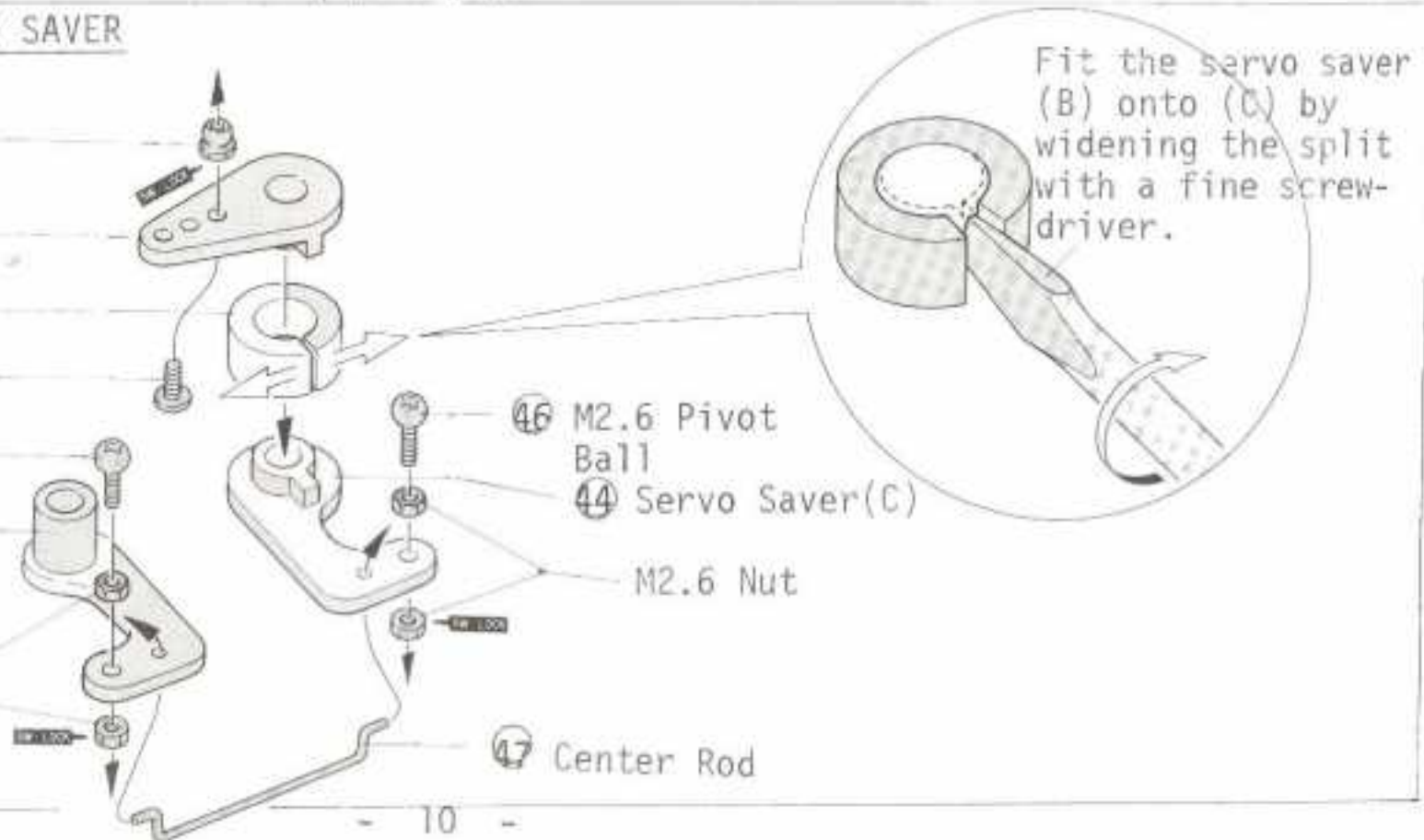

18 INSTALLATION OF SERVO SAVER

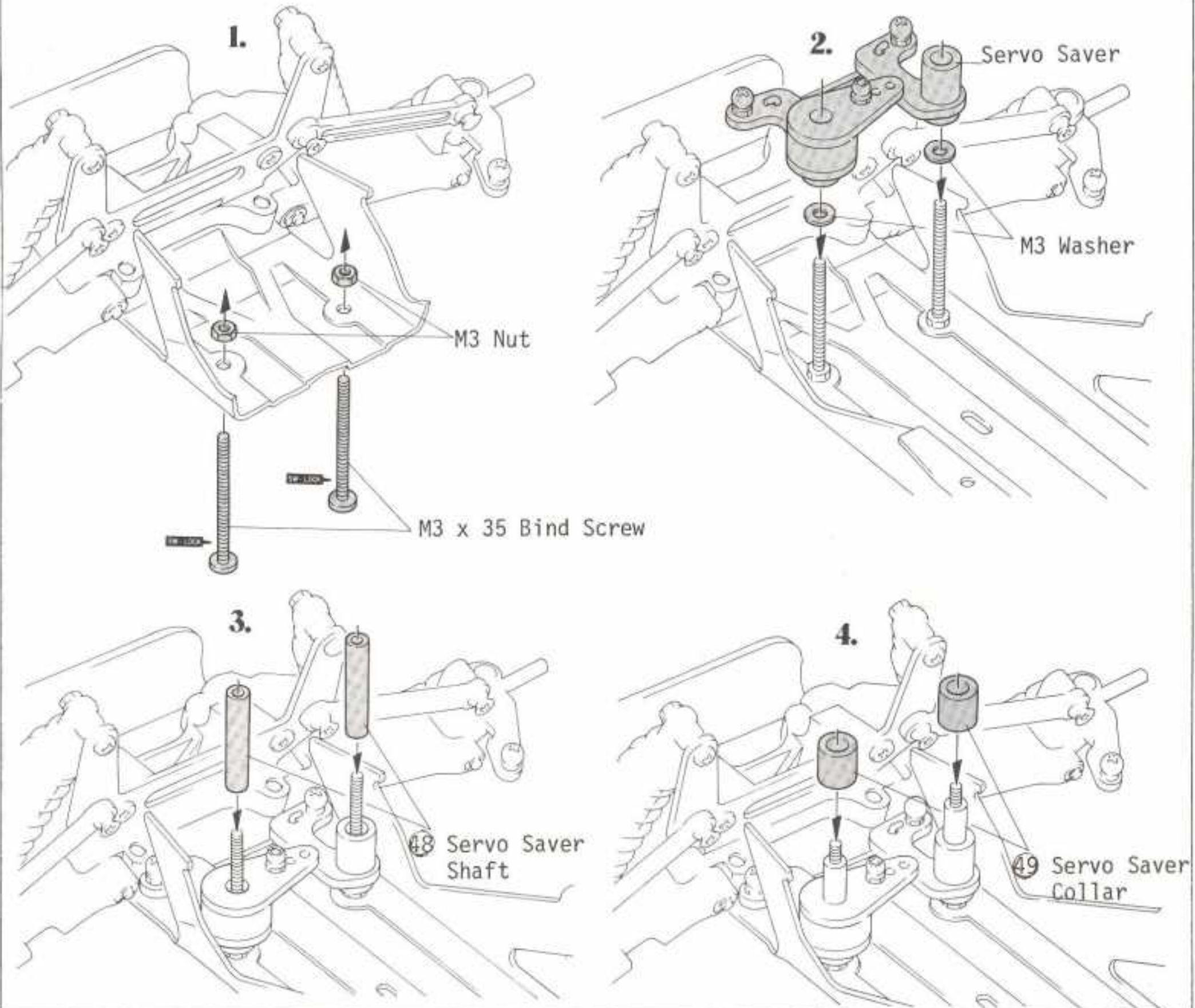

19 INSTALLATION OF TIE ROD

[Assembly of Tie Rod]

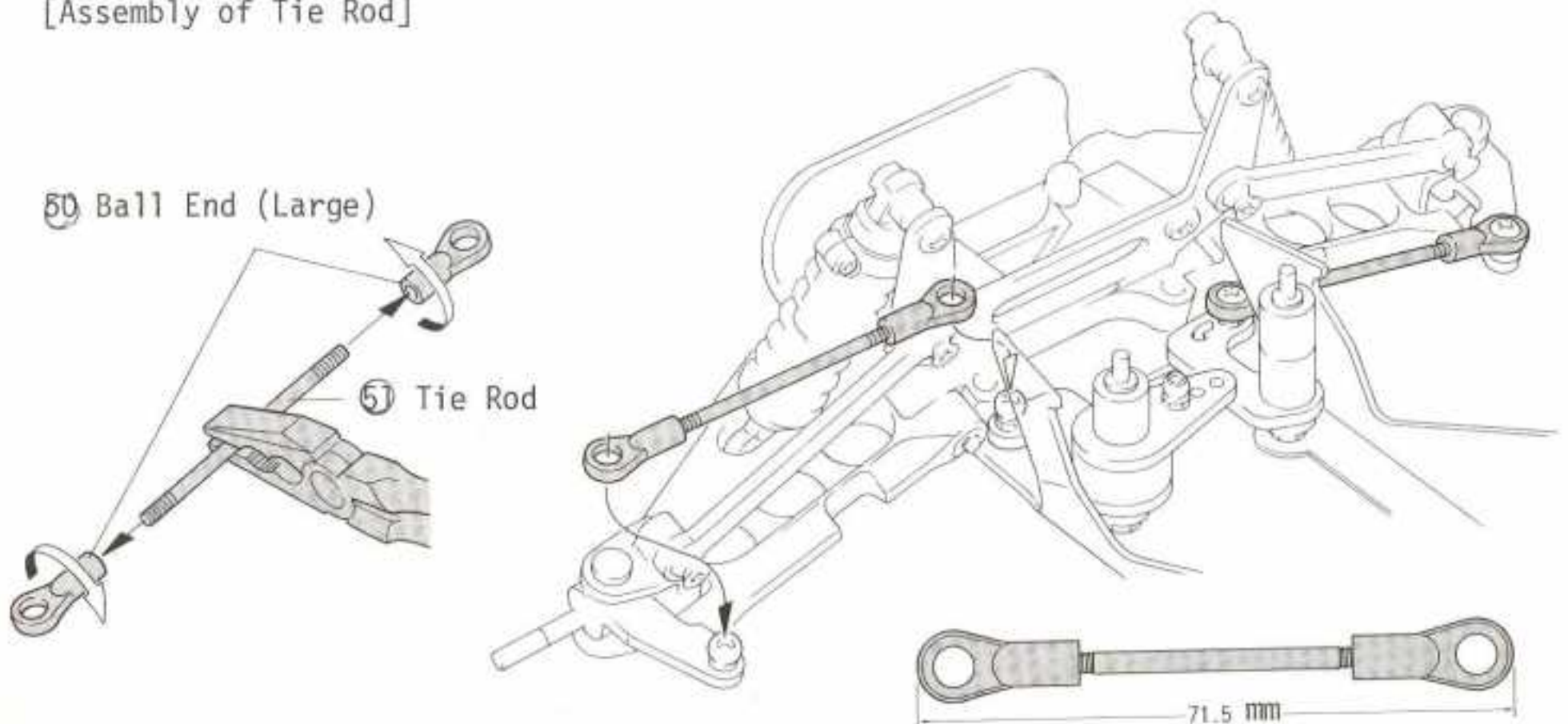

20 HOW TO CHECK RADIO SYSTEM

Follow steps 1-8.

1. Install the batteries into both the transmitter and receiver. If your radio is a rechargeable system, charge it as outlined in the manual that came with your set.
2. Unravel the receiver antenna and plug the servo and battery connectors into the receiver.
3. Extend the transmitter antenna.
4. Turn on the power switch of the transmitter.
5. Turn on the power switch of the receiver.
6. Set the small trim levers to the center position and make sure that both main control sticks are also centered.
7. Move both main control sticks slowly through their full travel. The servo horns should move in proportion to the movement of your sticks.
8. When trim levers and sticks are at their neutral positions the servo horns should be centered. You may now turn off the transmitter, then the receiver and unplug the servos and battery from the receiver.

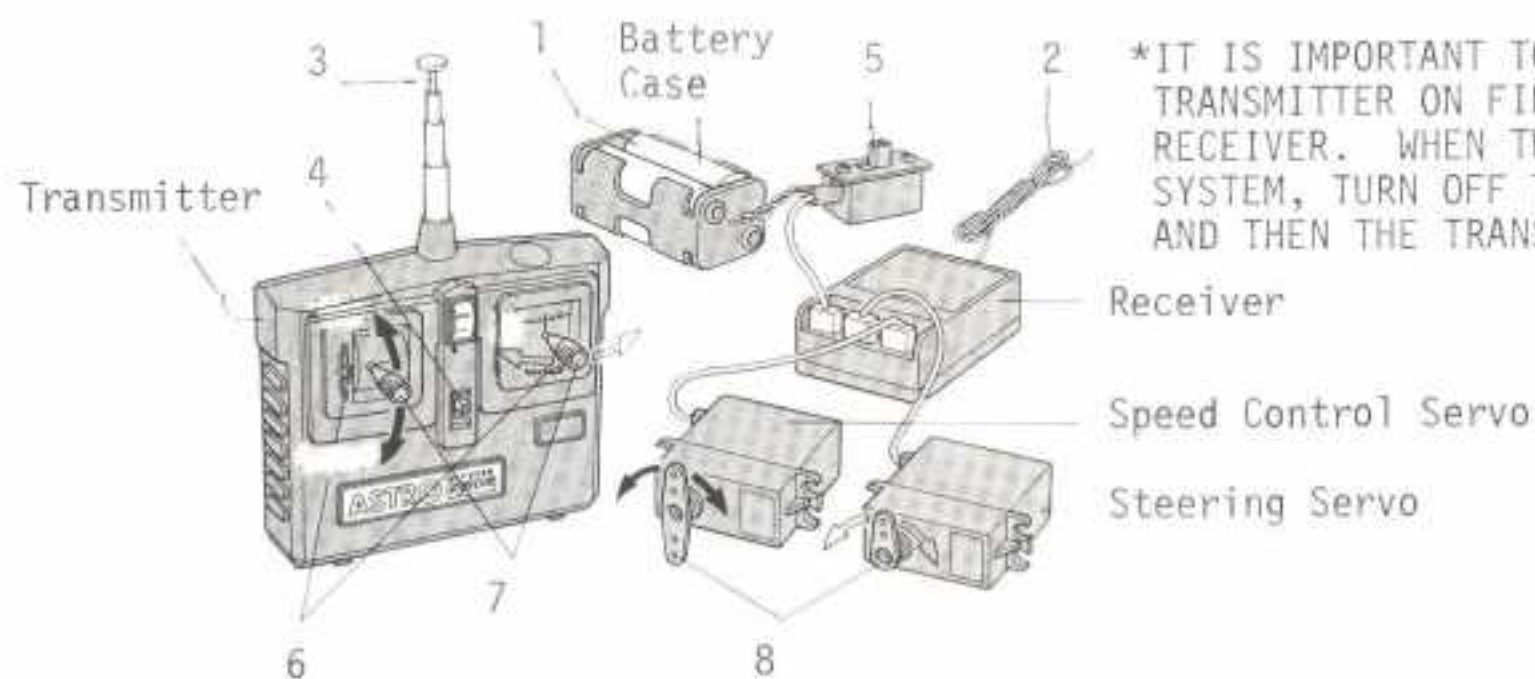

*IT IS IMPORTANT TO ALWAYS SWITCH THE TRANSMITTER ON FIRST... THEN THE RECEIVER. WHEN TURNING OFF THE SYSTEM, TURN OFF THE RECEIVER FIRST AND THEN THE TRANSMITTER.

A 2-channel radio control system is composed of a transmitter, receiver, two servos, and a battery holder (for the receiver).

- *Transmitter This is the part of the system that you hold in your hands to control the model. Information is sent to the receiver and servos via radio waves.
- *Receiver Receives the radio signals from the transmitter and sends them to the appropriate servo.
- *Servos It can be thought of as the "muscle" of the system. They actually move the controls of the model. The receiver tells them which direction to move and how much.
- *Antenna The transmitter antenna broadcasts the radio signal.
- *Antenna The transmitter antenna broadcasts the radio signal. The receiver antenna (which is no more than a small wire tuned to a precise length) picks up the signals so that the receiver can decode them.
- *Trim Levers Adjust the neutral position of the servos from the transmitter. Trim levers provide fine tuning of the steering and speed control.
- *Battery Meter ... Allows you to see the condition of your transmitter batteries.
- *Servo Horn A small arm or wheel on a servo that transfers the movement of the servo.

21 INSTALLATION OF STEERING ROD

[Processing of Servo Horn]

Trim the shaded portion from your servo horn.

Hole may have to be enlarged slightly.

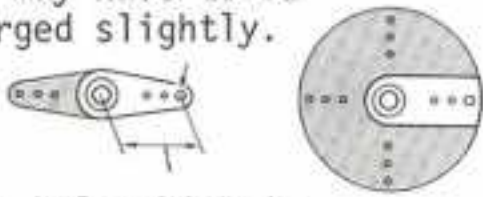

Use a hole which is away from the center pivot for 13mm.

[Assembly of Steering Rod]

62 Ball End (S)

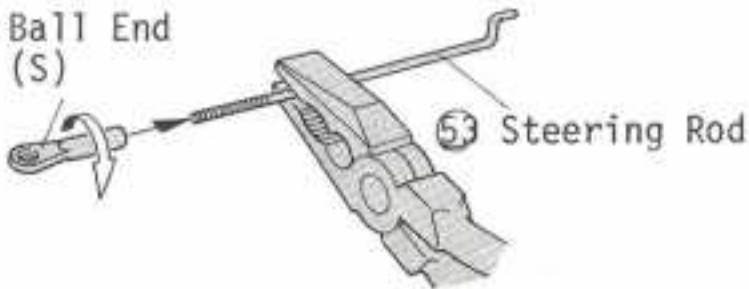

67 Servo Stay

Servo horn is neutral position.

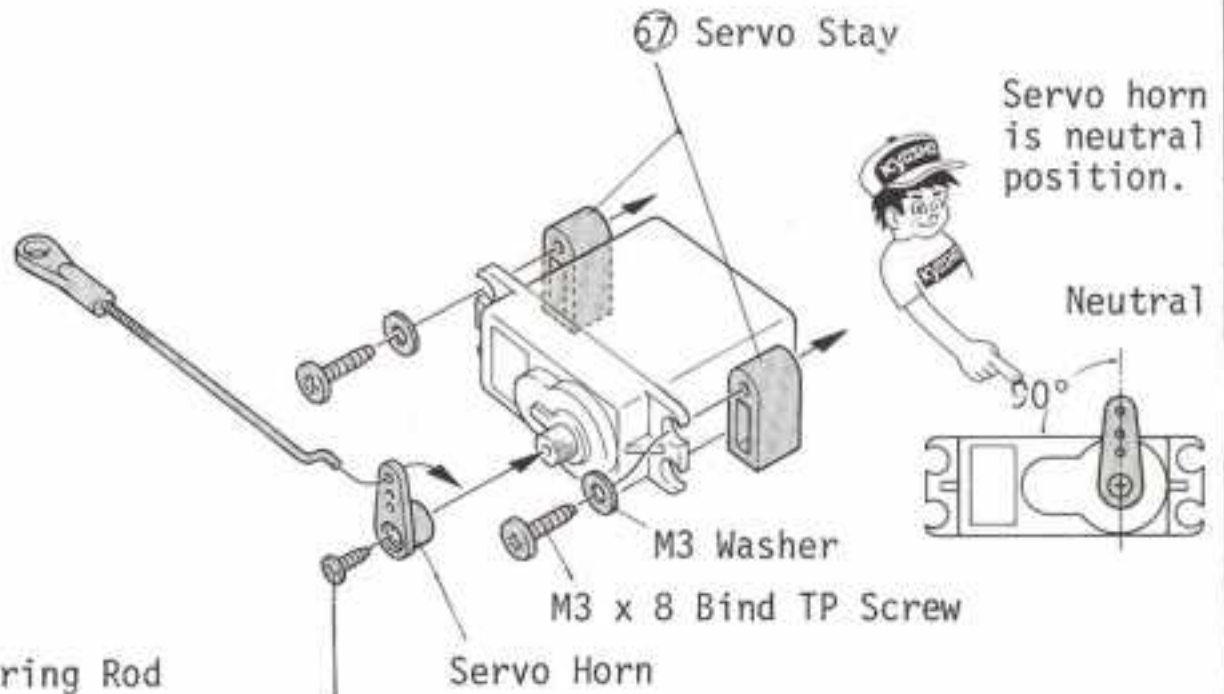

M3 Washer

M3 x 8 Bind TP Screw

Servo Horn

Use the screw included with your radio.

22 INSTALLATION OF STEERING SERVO

The length of control rod can be varied by turning the ball end.

Getting longer

A It becomes shorter.

Bend

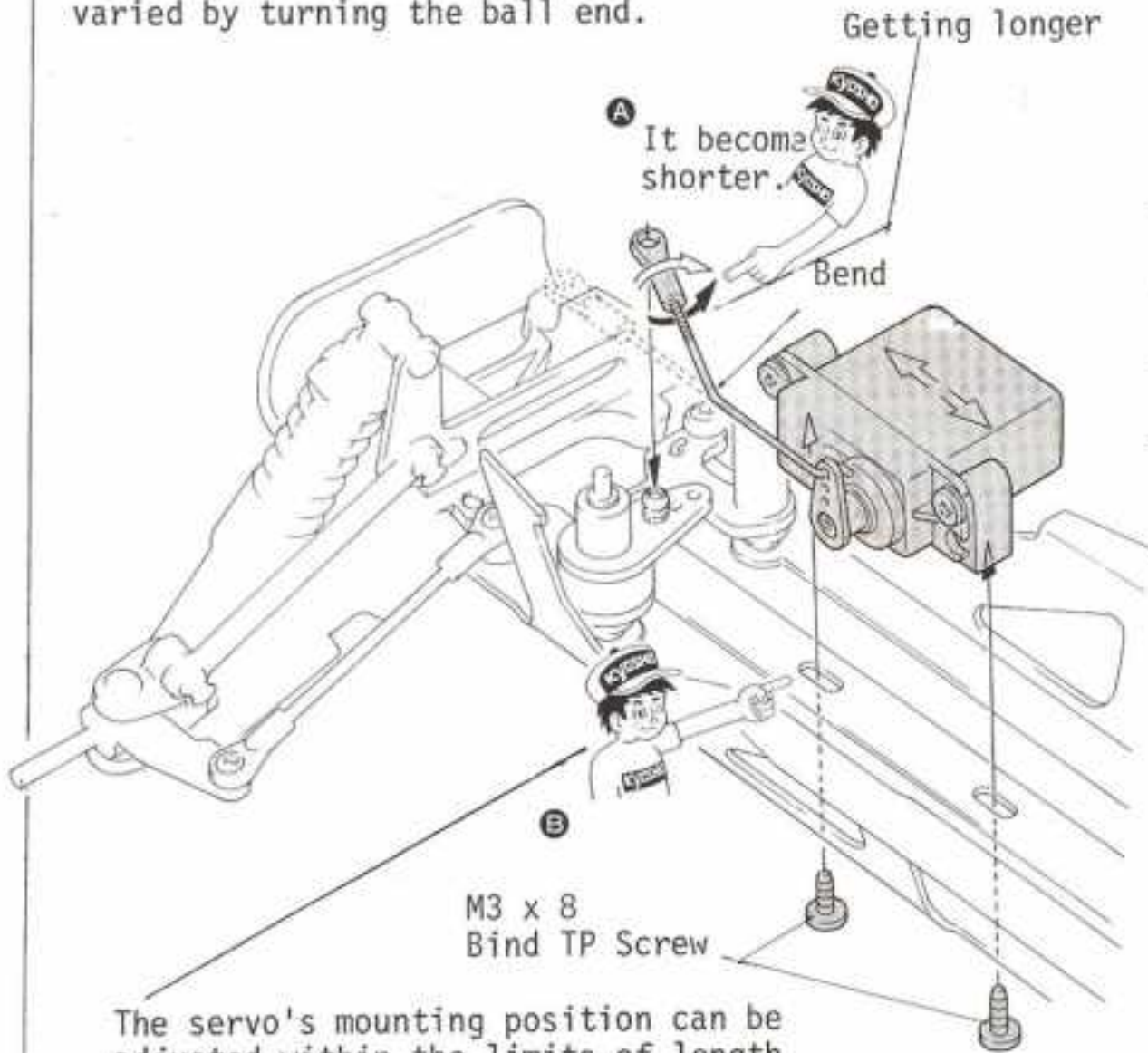

M3 x 8 Bind TP Screw

The servo's mounting position can be adjusted within the limits of length of the oval hole B.

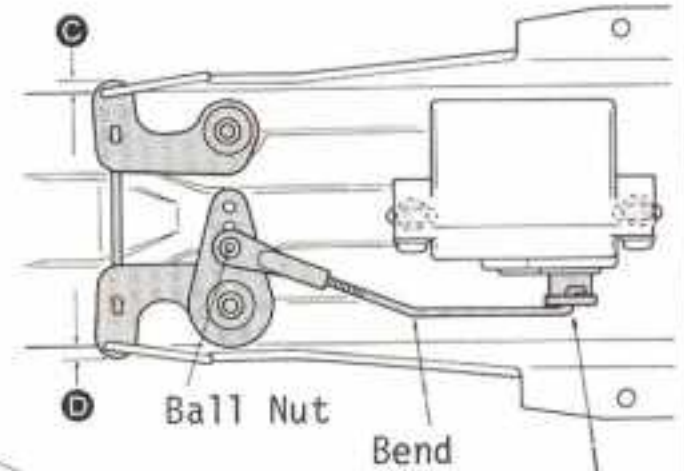

Ball Nut

Bend

Servo horn should be is neutral.

Adjust the length of control rod A and the fixing position of B so that the clearance C and D will be the equal.

23 ASSEMBLY OF SPEED CONTROL

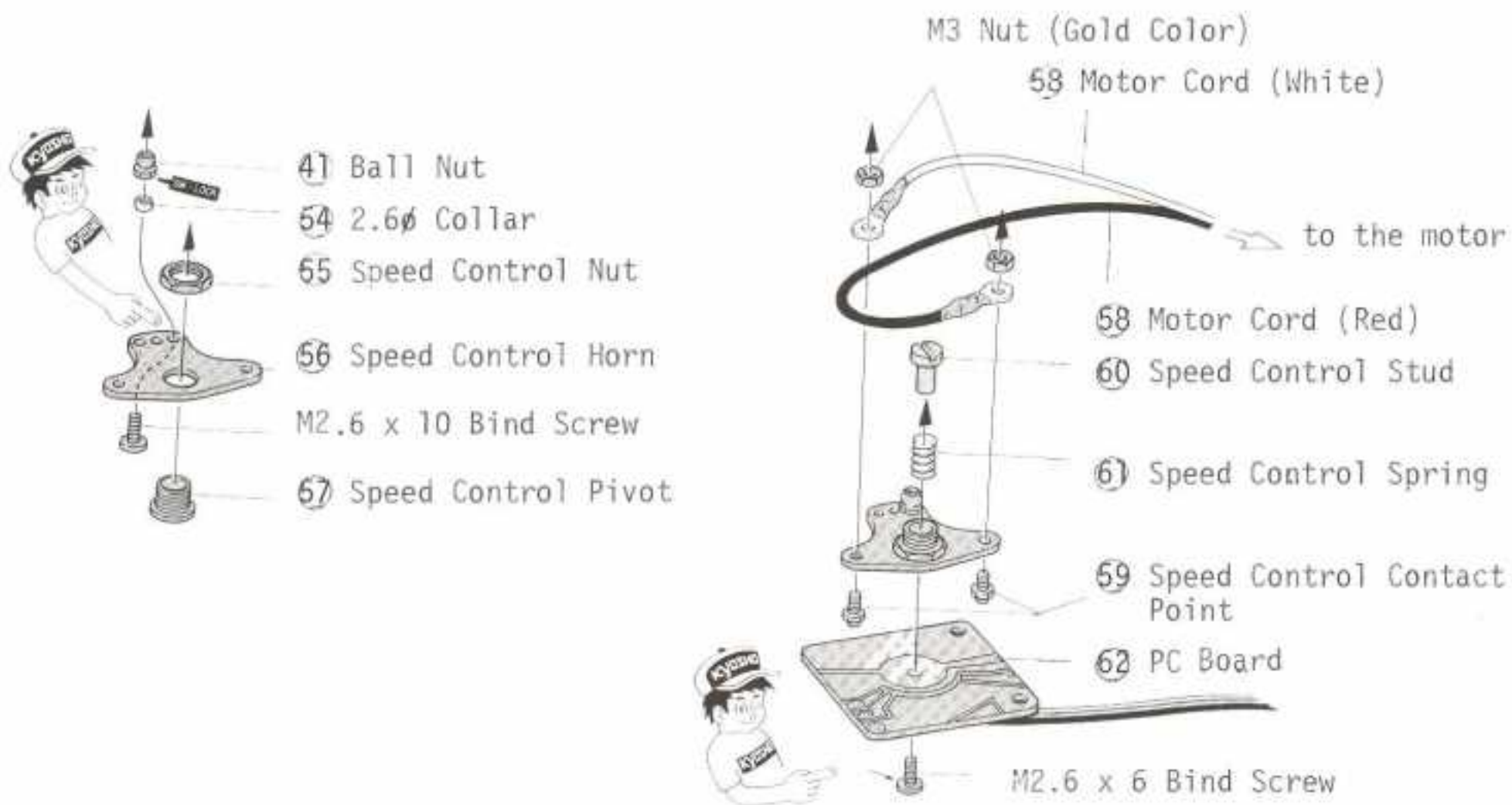

Apply epoxy for tightening

24 INSTALLATION OF BATTERY CONNECTOR

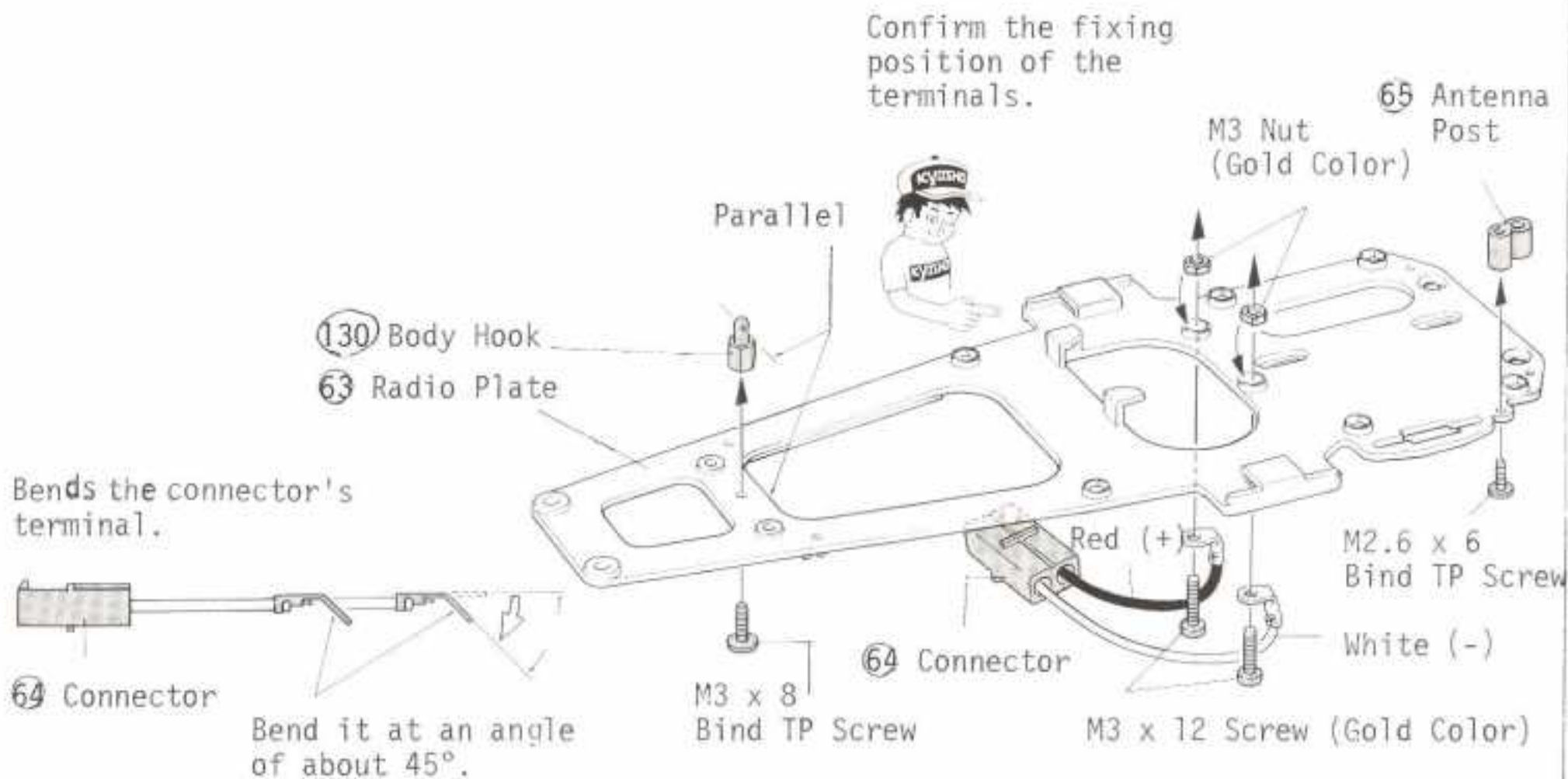

25 WIRING OF RECEIVER BATTERY



For those who use a BEC type radio, please skip the step 25, and proceed to the next step.



The battery that powers the motor also powers the receiver. Use great care and do not allow polarity to be reversed. Also, do not allow 7.2V to flow directly into receiver.

The colors of the lead wires are different depending upon radio manufacturer. Most use red for positive (+) and black for negative (-). The exception being Cox and Airtronics (Sanwa). Their (+) lead has a white stripe and the middle lead is (-).

Battery box is not used

1.

Cut off wires from radio box as shown.



Use the switch which is provided with your radio.

2.

Connect the leads from the R/C unit switch and the regulator.

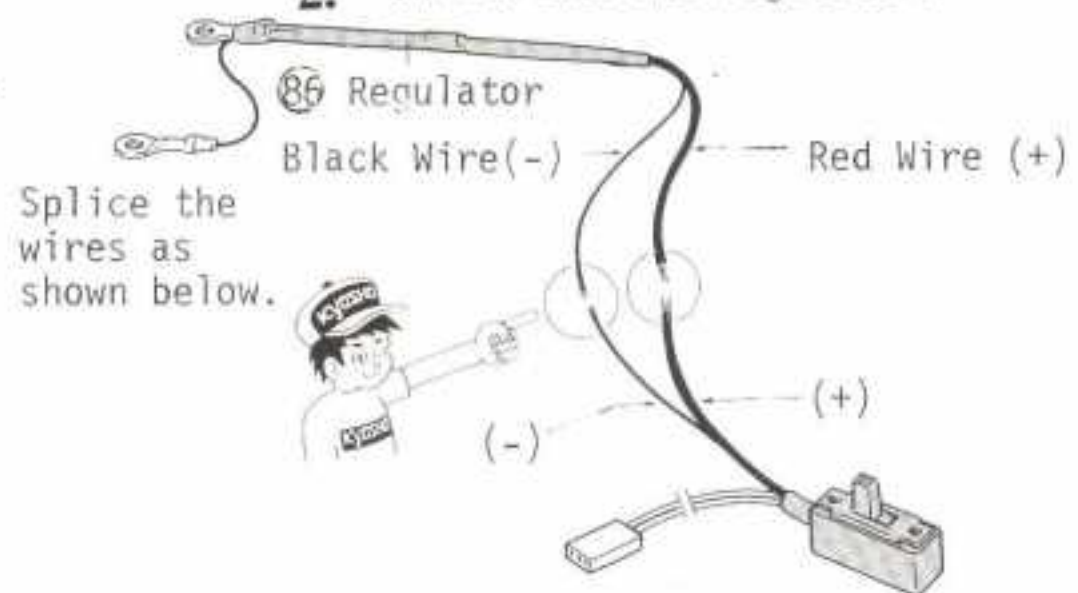

Splice the wires as shown below.

[How to Connect the lead wire]

1.

Trim off about 5mm.



2.

Splice the cords of the same polarity.

For ensuring the job, solder the spliced leads.



3.

Insulate the connection points with vinyl tape to prevent a short-circuit.



26 INSTALLATION OF SPEED CONTROL

[Orientation of Mounting]

Lay it along the edge of the oval perforation.

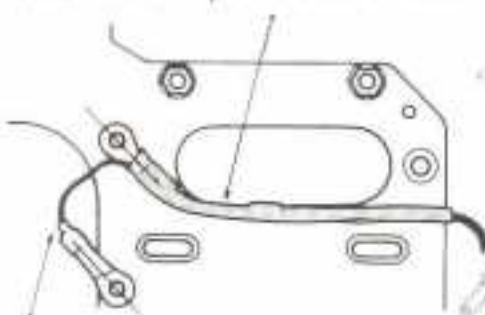

Black Wire (1)

Make sure the positive and the negative not to make mistake.

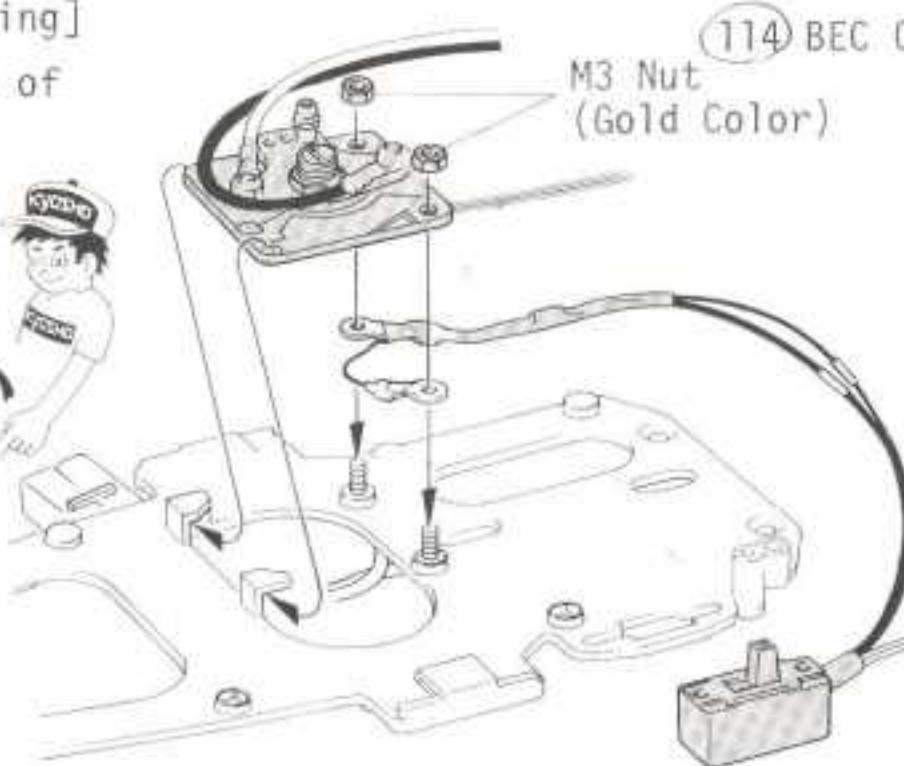

M3 Nut (Gold Color)

114 BEC Connector

Red Wire (+)

Black Wire (-)



The radio contained in the box with this logo is the BEC type. As shown in step 25, the radio does not use the regulator 86, also the wiring for the switch is not required. When using this type of radio, fix the BEC connector as illustrated.

When arranging the BEC connector, do not mistake the positive (red wire) with the negative (black wire). The improper polarity may damage the radio.

27 INSTALLATION OF SPEED CONTROL SERVO

[Processing of Servo Horn]

Trim the shaded portion from your servo horn.

Hole may have to be enlarged slightly.

67 Servo Stay

Use a hole which is away from the center pivot for 15mm.

Neutral

M3 Washer

M3 x 8 Bind TP Screw

Servo Horn

Use the screw included with your radio.

M3 x 8 Bind TP Screw

Screw provided with the switch.

Switch Plate

Switch

28 SPEED CONTROL LINKAGE

[Assembly of Speed Control]

68 Ball End (S)

1.

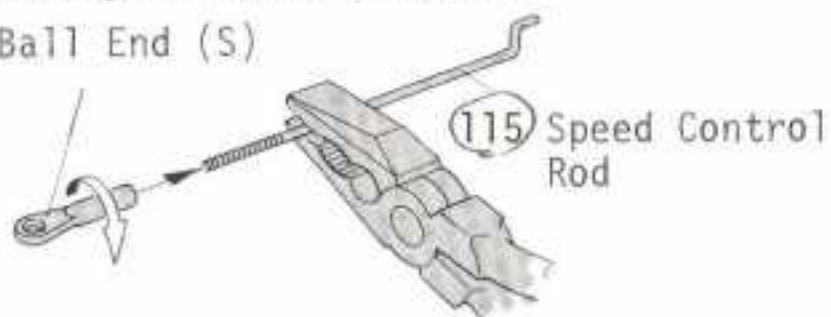

115 Speed Control Rod

a The length of control rod can be varied by turning the ball end.

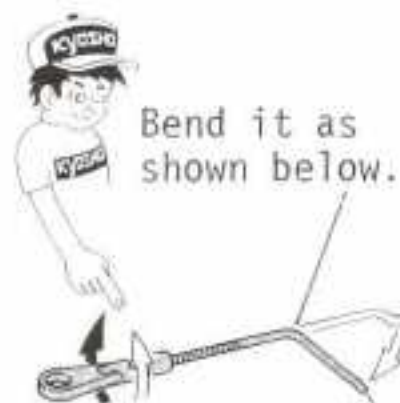

2.

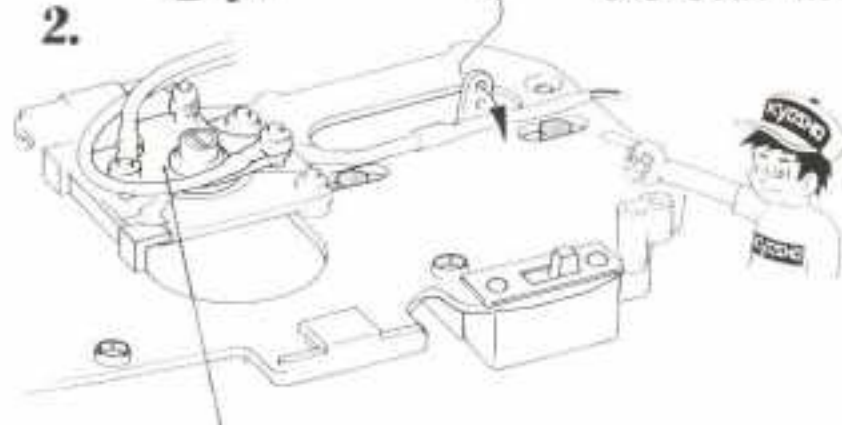

b The servo's mounting position can be adjusted within the limits of length of the oval hole B.

[Top of View]

90° Neutral

Paralle [Side of View] Bend it.

90° Neutral

Reverse



Neutral

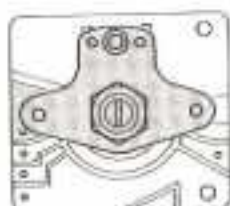

Low Speed



Medium Speed

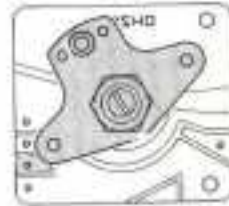

High Speed



Adjust A and B in such a way that the speed controller will position in neutral as one of the illustrations at right indicates.

29 MOUNTING OF RADIO PLATE

Pay attention not to mistake (R) for (L).

[Top of View]

M4 x 8
Truss Screw

M3 Nut
29 M3 Plastic Nut

68 Body Stopper (R)

132 Body Stopper (L)
M3 Nut

M4 x 10
Flat Head
Screw

118 Main Chassis

M2.6 x 12
TP Screw

M3 x 6
Bind Screw

M3 x 6
Bind Screw

30 FIXING OF RESISTOR

69 Heat Sink
(A)

120 Resistor

70 Heat Sink
(B)

M3 Nut

M3 x 6 Bind Screw

71 Center Gear Shaft

[This is a view of the assembly
looking at from behind]

Lead the orange
cord out of the
heat sink.

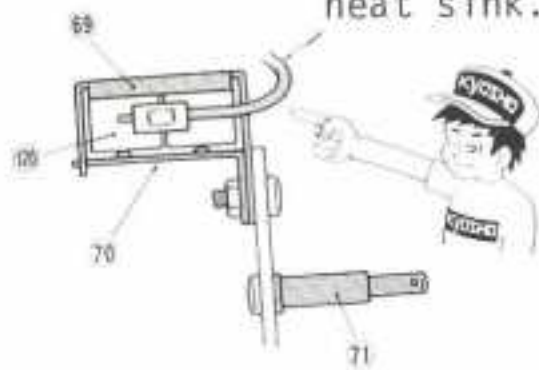

31 INSTALLATION OF CENTER GEAR

This hole is for fixing the motor guard, which is an optional part. If you don't attach the motor guard, cut out a piece of the decal, which is excessive, and cover the hole for preventing dusts from penetrating.

A remainder of the decal

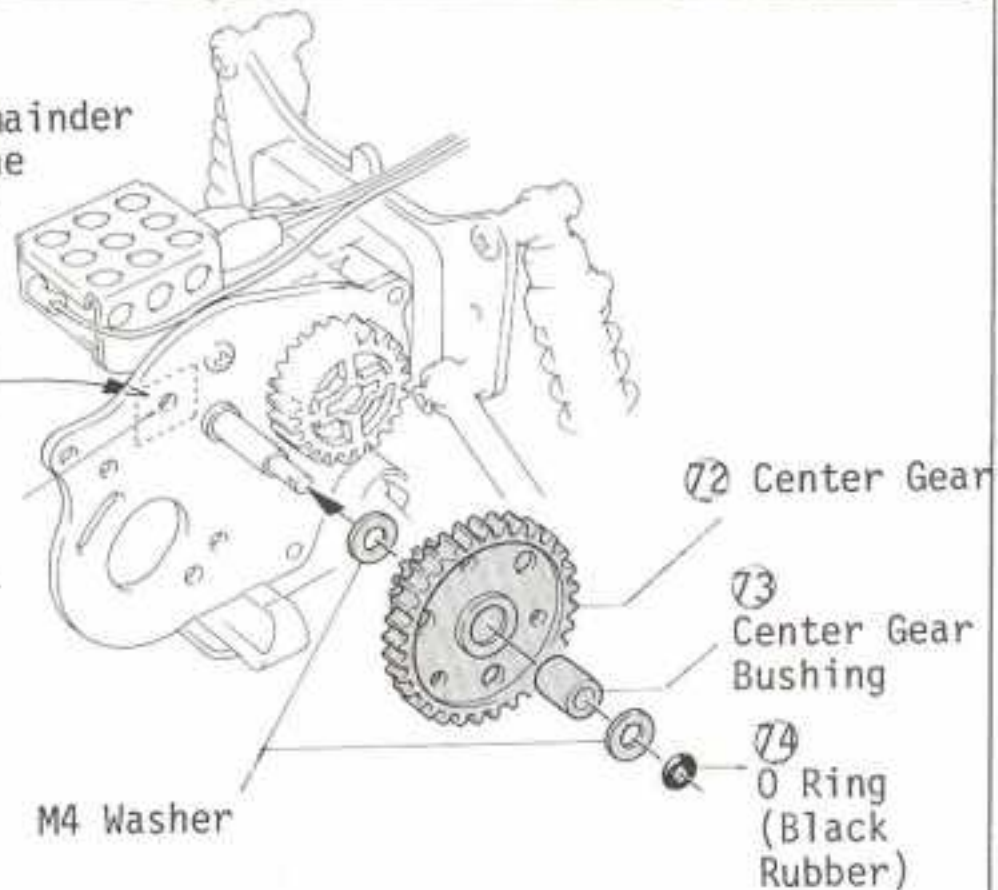

72 Center Gear

73 Center Gear Bushing

74 O Ring (Black Rubber)

M4 Washer

32 INSTALLATION OF MOTOR

Cut out any extra part of the decal into the size as shown below, and cover the hole on the motor.

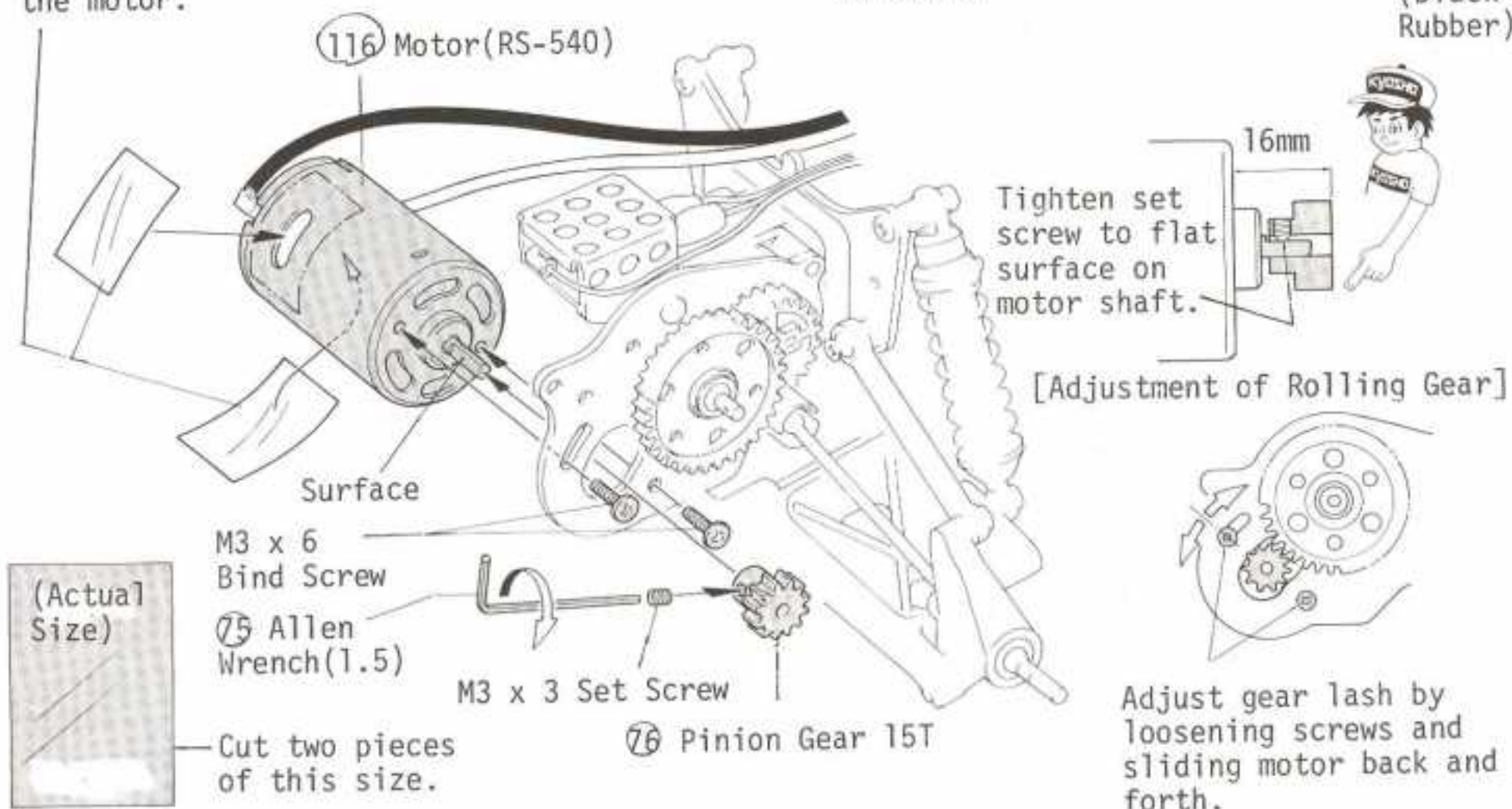

116 Motor (RS-540)

Surface

M3 x 6 Bind Screw

75 Allen Wrench (1.5)

M3 x 3 Set Screw

76 Pinion Gear 15T

Tighten set screw to flat surface on motor shaft.

[Adjustment of Rolling Gear]

Adjust gear lash by loosening screws and sliding motor back and forth.

(Actual Size)

Cut two pieces of this size.

33 INSTALLATION OF GEAR COVER

77 Gear Cover

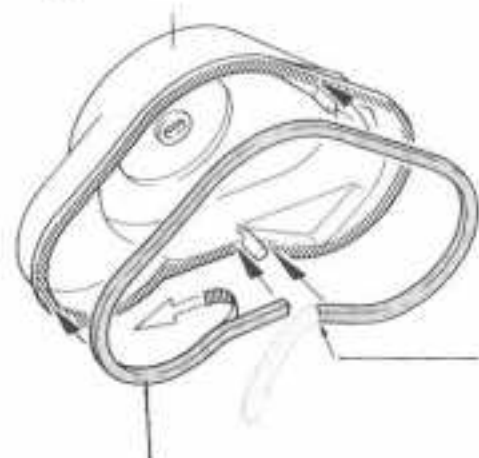

Cut the seal to length.

78 Gear Cover Seal (Home Rubber)

(Unseal them from backing and seal them on striped portion.)

54 2.6φ Collar

M2.6 x 12 TP Screw

79 Hook Pin

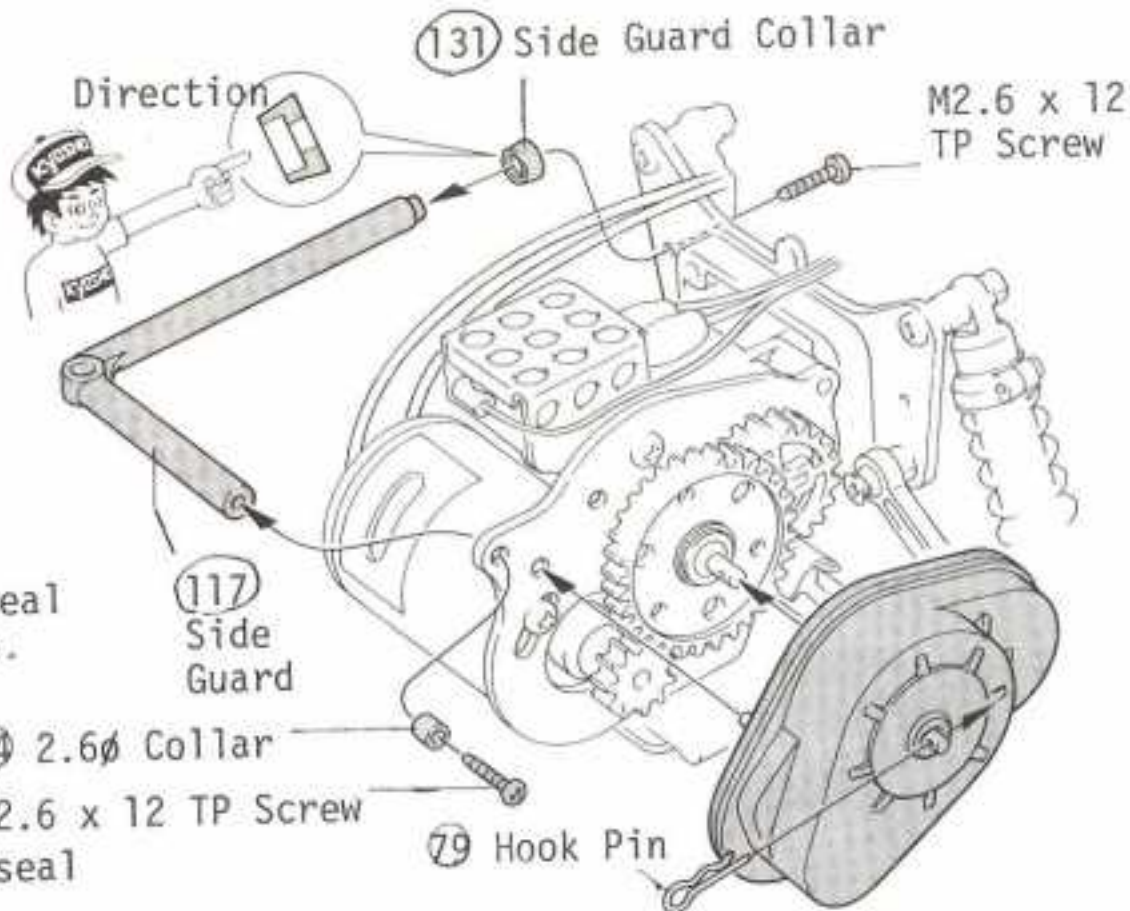

131 Side Guard Collar

M2.6 x 12 TP Screw

Direction

117 Side Guard

54 2.6φ Collar

M2.6 x 12 TP Screw

79 Hook Pin

34 FABRICATION OF TIRE AND WHEEL

[Front]

1. Cut off 83 and 86.

Runner



2. Remove the mold runner and smooth the cuts.



83 Front Wheel (2)

83 Front Wheel (2)

3.

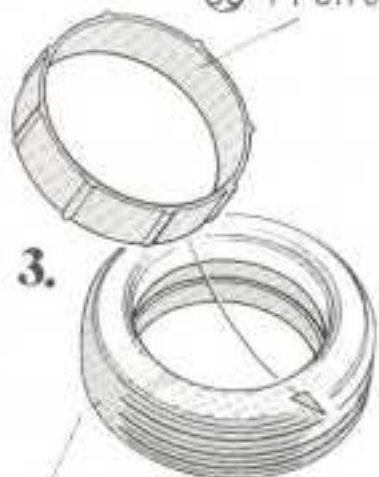

80 Front Tire

4.

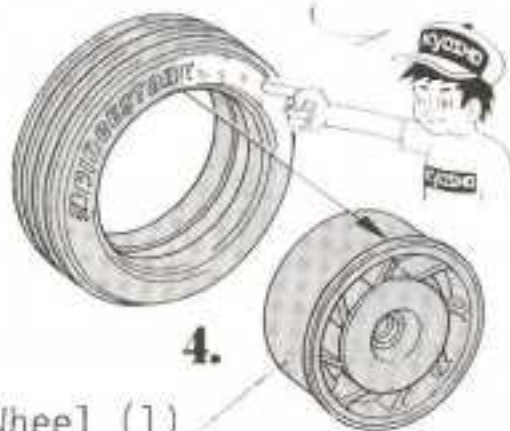

82 Front Wheel (1)

Cement the tire and the wheel by applying cyanoacrylate adhesive along the seam.

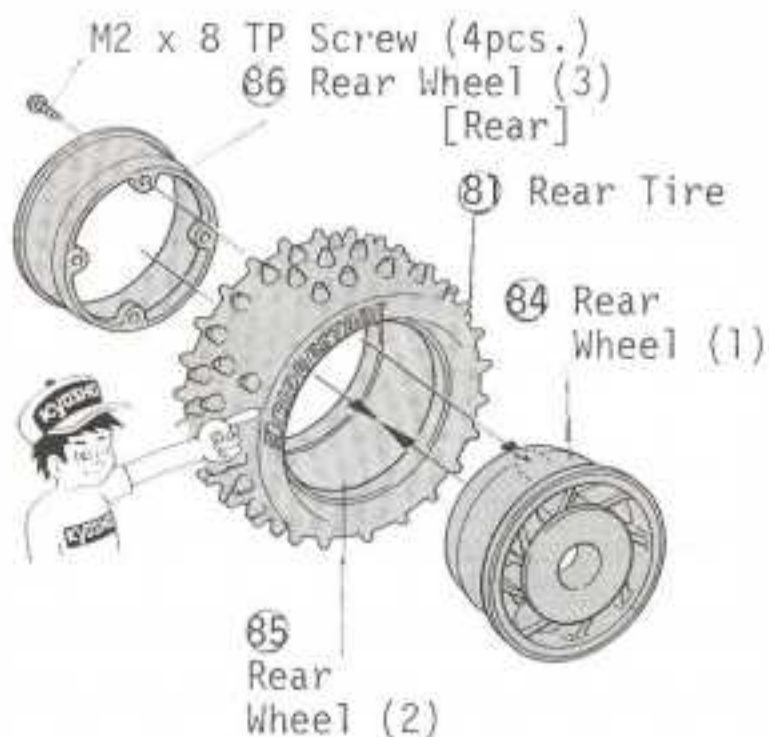

35 MOUNTING OF TIRE

*The optional ball bearings are adapted here.

In place of plain bearings, fit the 4mm dia. x 8 ball bearings, parts No. 1903.



87 4φ x 8 Plastic Bushing

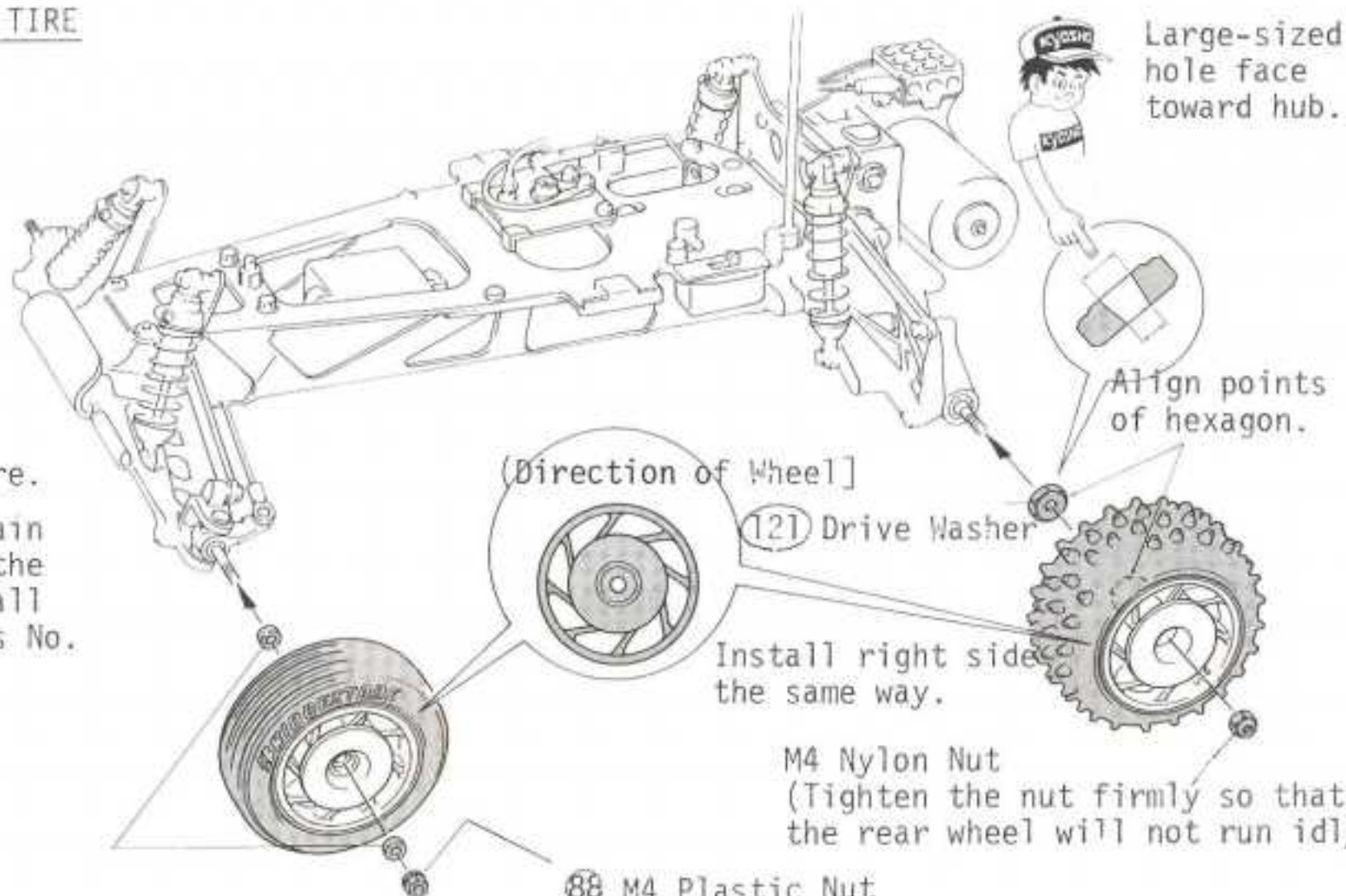

(Direction of Wheel]

121 Drive Washer

Install right side the same way.

M4 Nylon Nut (Tighten the nut firmly so that the rear wheel will not run idly.)

88 M4 Plastic Nut (Do not tighten the nut too tight so that the front wheel will turn smoothly.)

36 INSTALLATION OF RECEIVER

Affix both sided tape under the receiver.

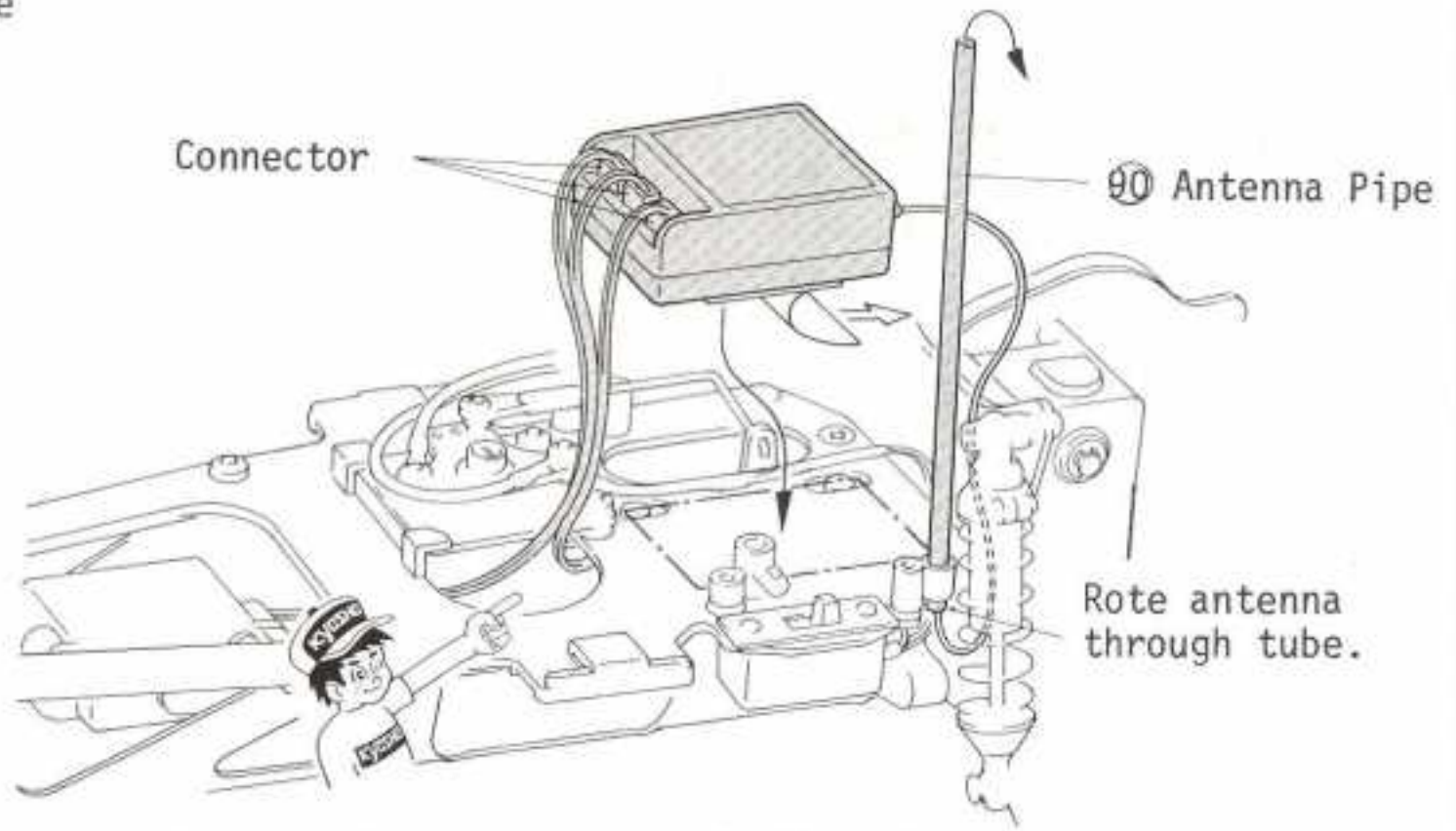
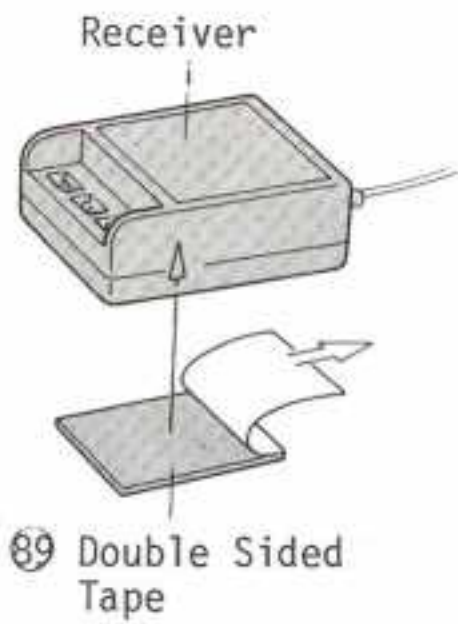

Arrange the connector cords through this opening and plug the one into the receiver.

37 CUTTING OUT BODY

*Drill three holes at the marked points on the car body.

*Cut off the portions along with the cutout line.

4mm hole (For Body Hook)

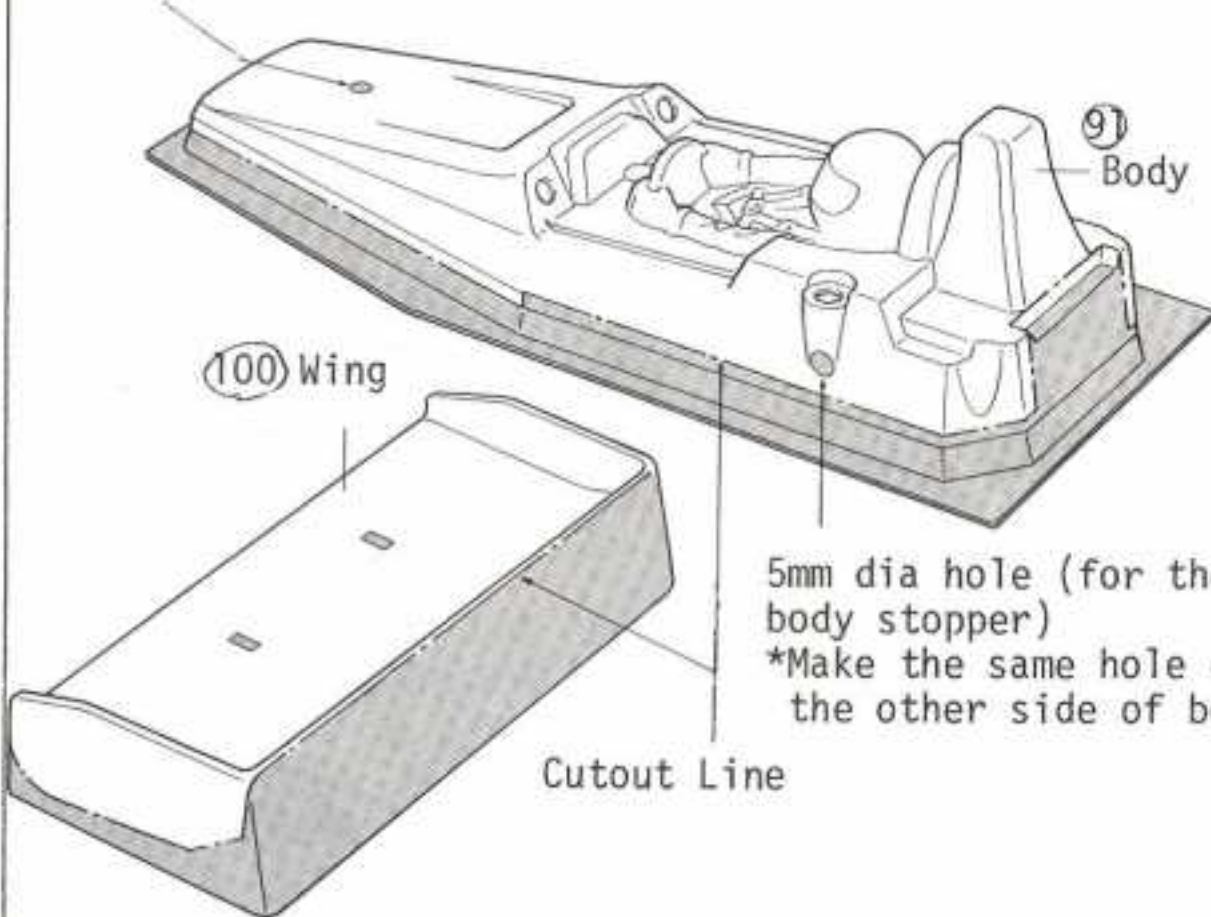

Smooth the cuts with a sander.

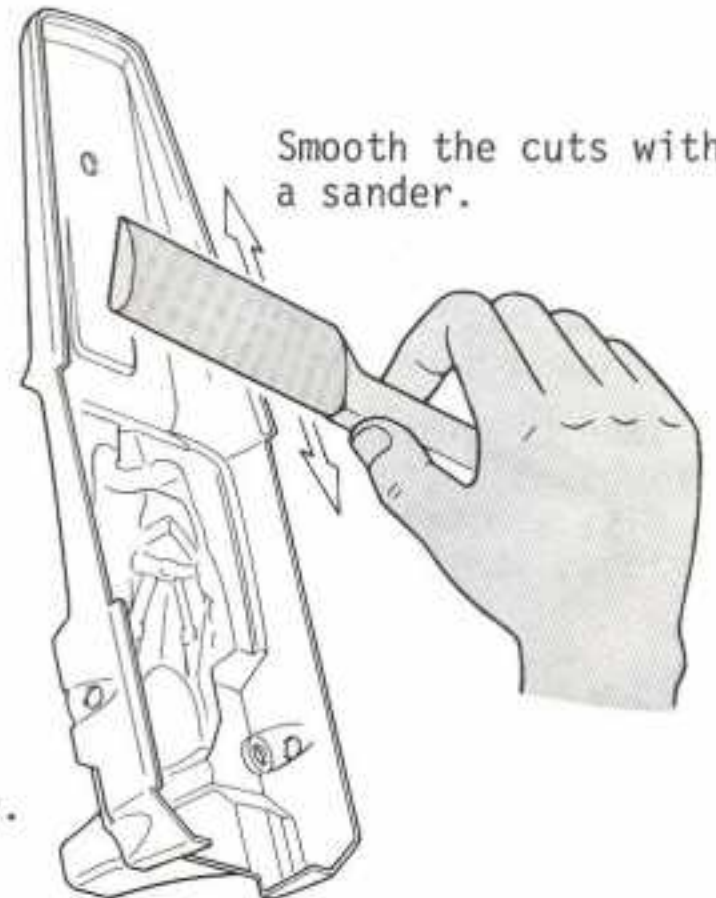

38 PAINTING

First, wash the body to remove any oil or dirt. Rinse thoroughly. Paint the inside of the body. You can obtain a color scheme by masking a portion with tape then removing the tape and painting. Apply the lightest color last.

Mask the windows with something like Micron Line Tape and paint it any color at your choice.

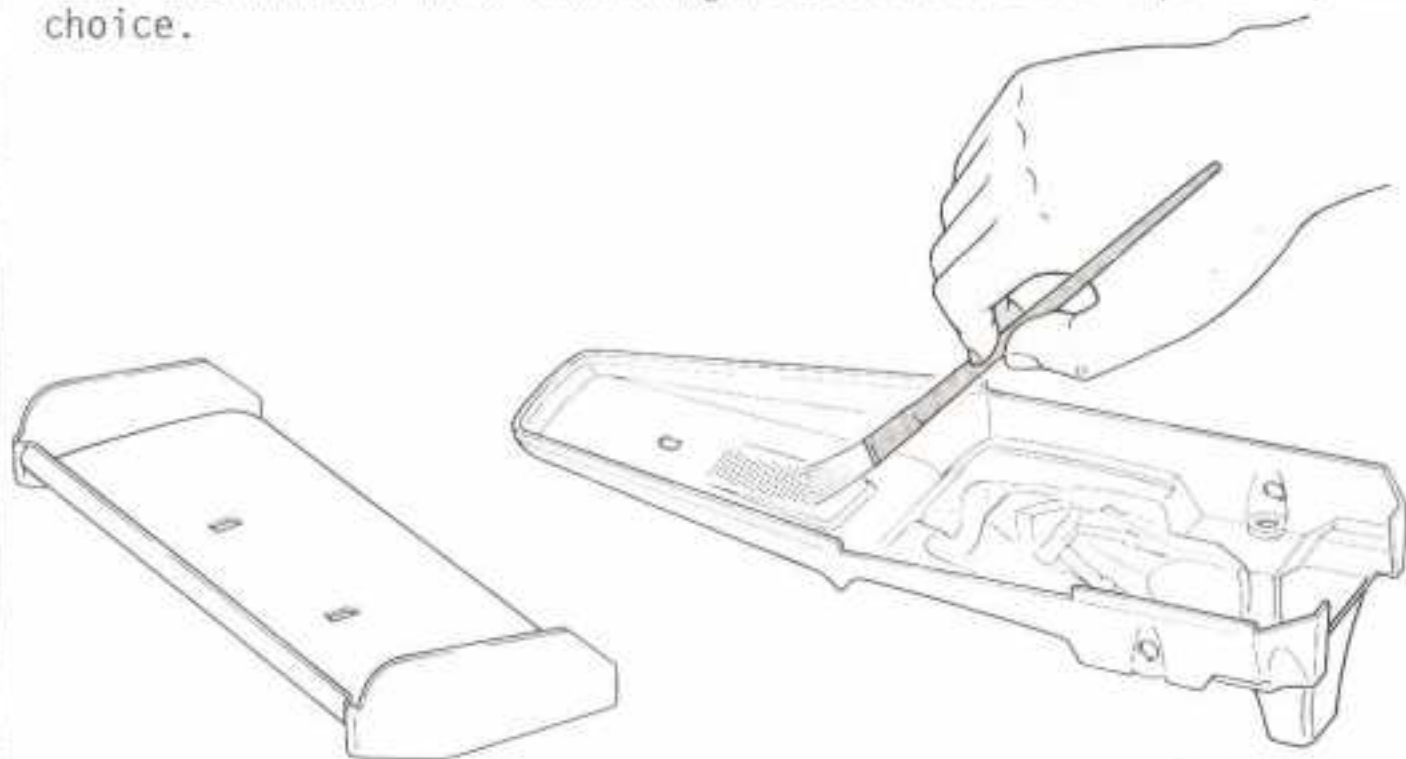

Micron-Line tape enhances the appearance of any model.



Polyca Color Paint is available for painting your Lexan Bodies. 12 great looking colors!



Polyca Color

39 MASKING OF BODY

Cut out the decals as close as to the cutout line, and affix them as shown.

Cut away the part of decal on the hole.

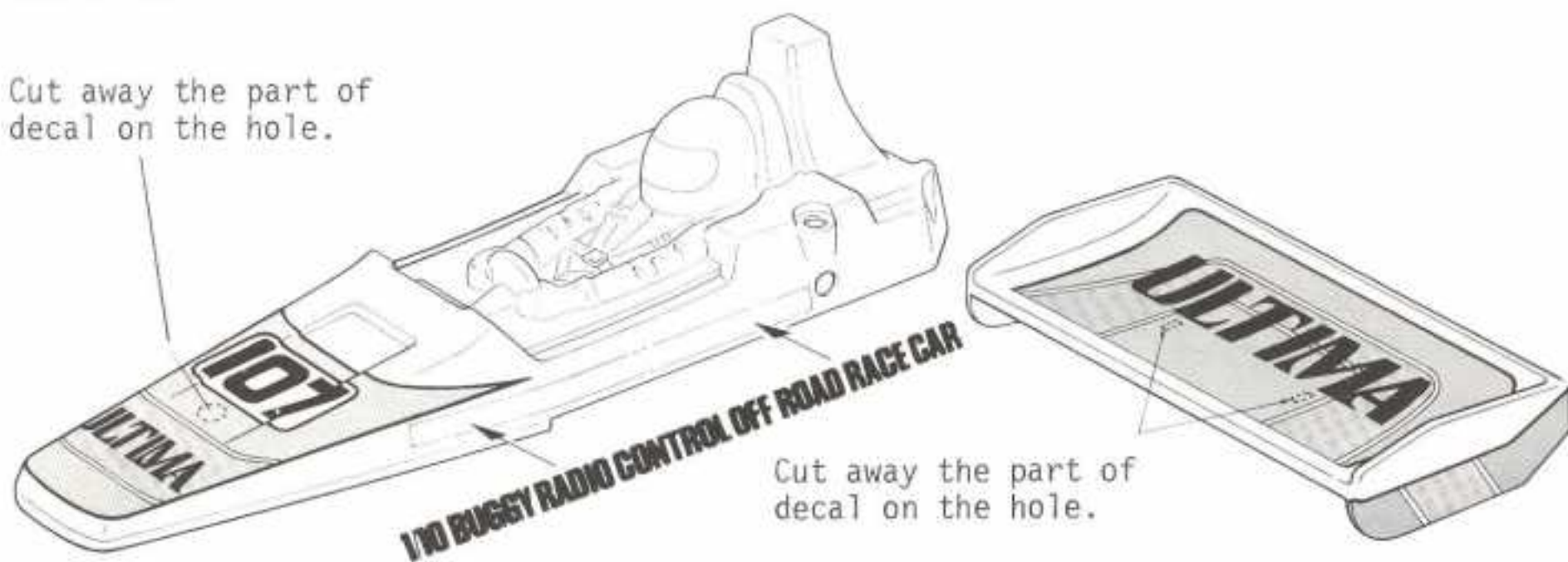

Cut away the part of decal on the hole.

40 ASSEMBLY OF ROLL CAGE

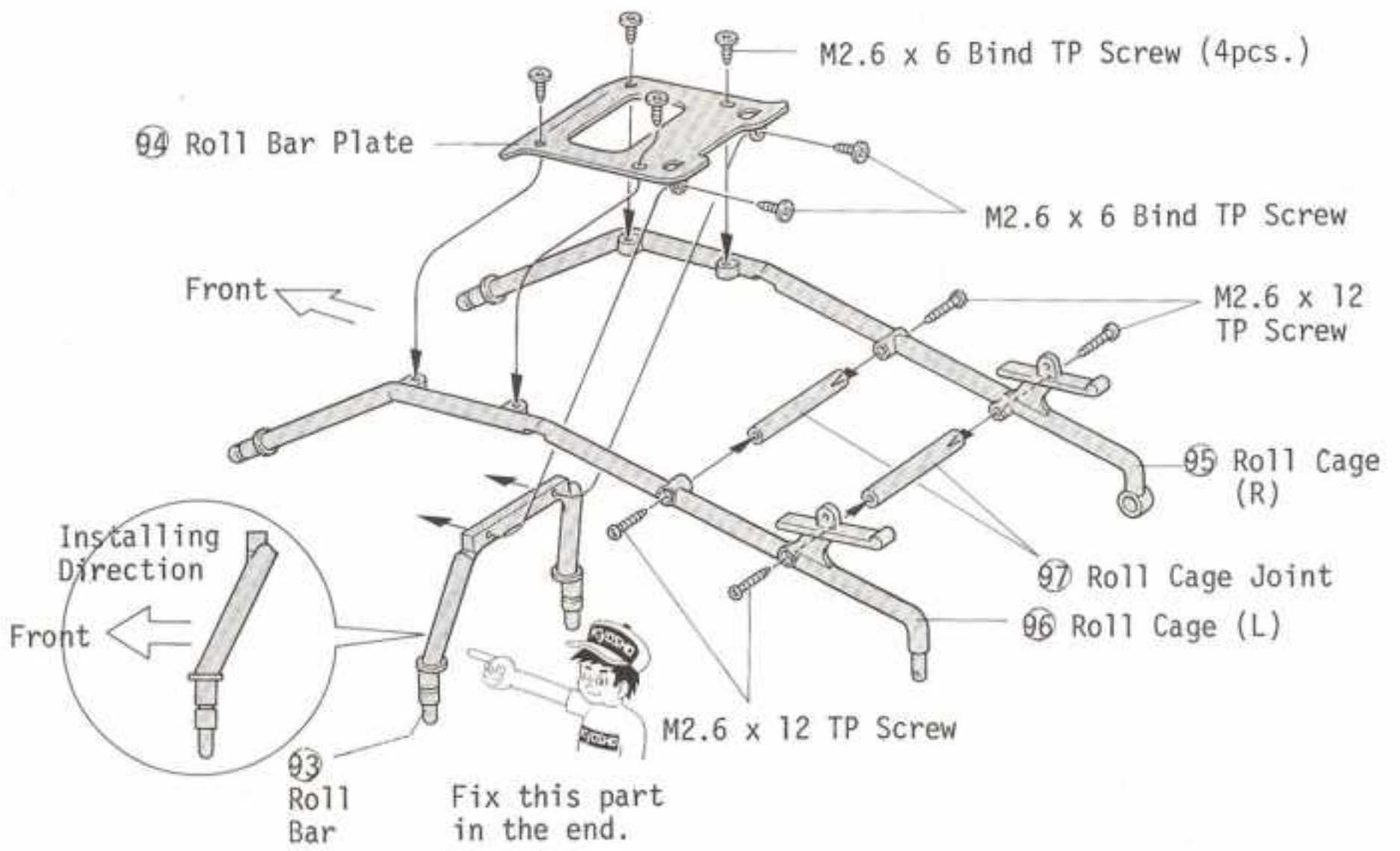

41 INSTALLATION OF ROLL CAGE

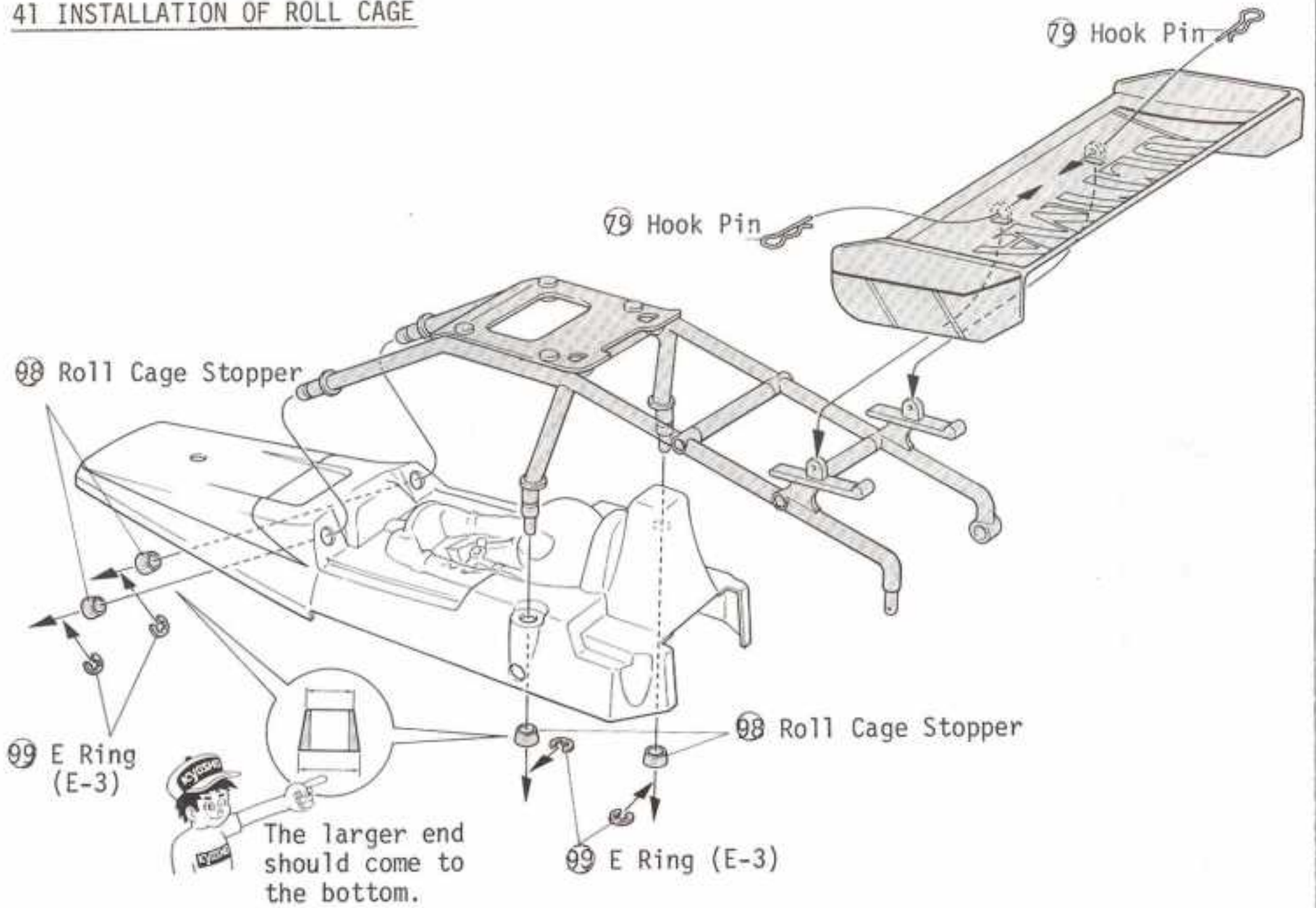

42 INSTALLATION OF BODY

Install steps ① to ⑧ in order.

Fasten the cords of the speed controller and the resistor. Give some slackness to the controller cord since the speed controller will swing.

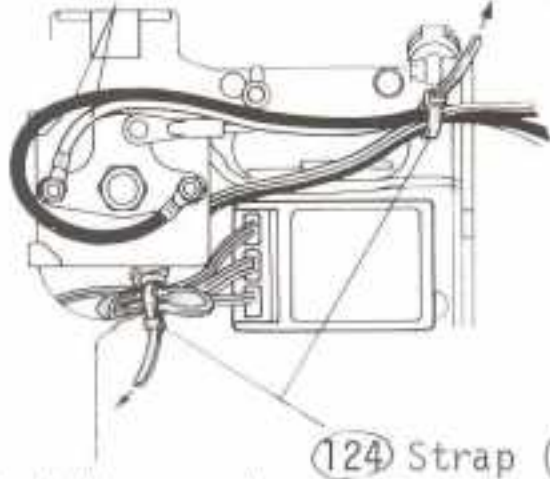

⑫④ Strap (S)

Bind the cords of the radio control units.

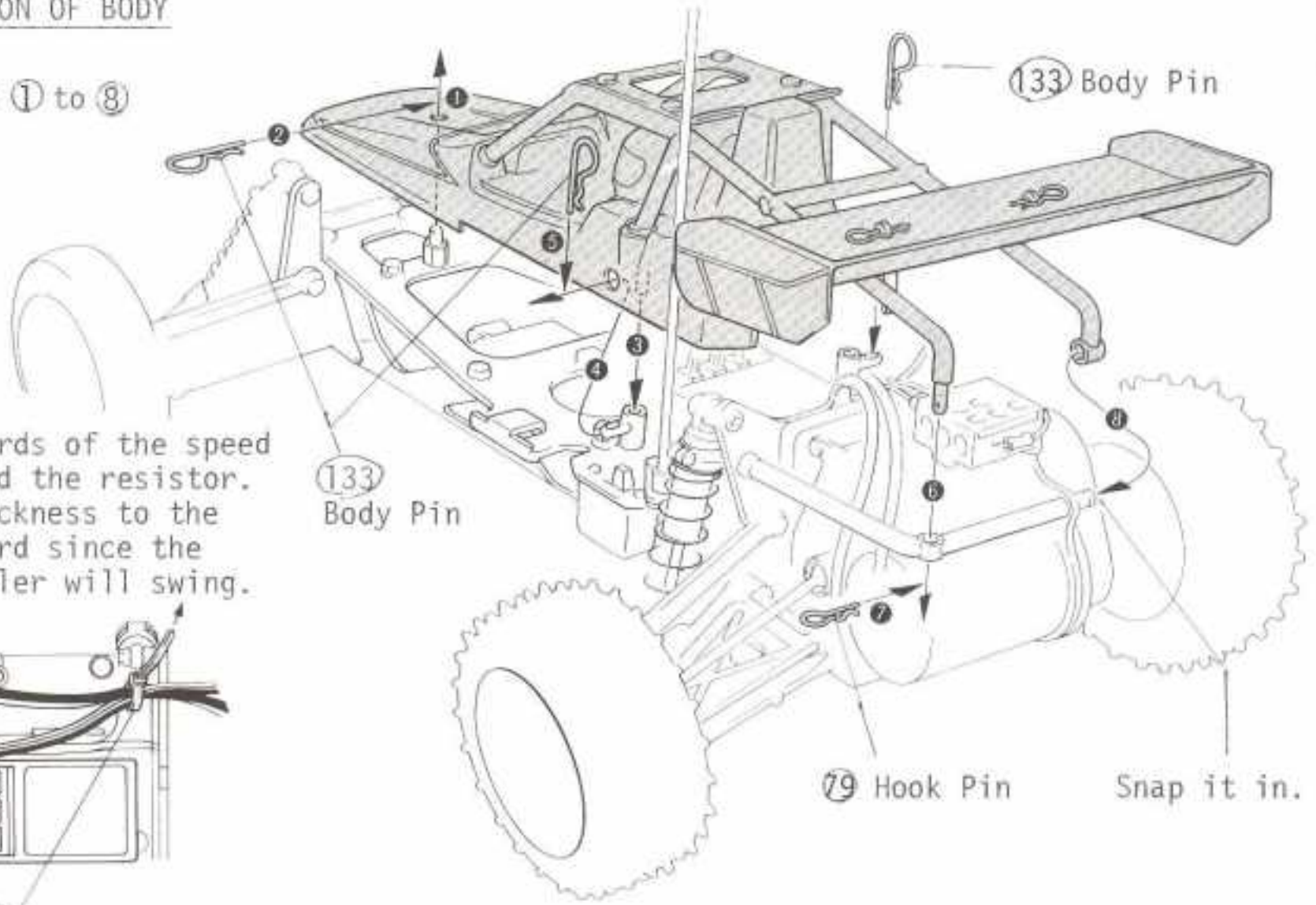

43 MOUNTING OF BATTERY

[Charging Ni-Cad Battery]

Charge your battery fully before running your model all the time.



Household 100V Outlet
Battery Charger
(Kyosho has several kinds of chargers. Select which-ever suitable for your requirement from those listed on page 3.)

Ni-Cad Battery (Not included in the kit.)

YOU HAVE TO TAKE AWAY THE BATTERY PACK WHEN YOU KEEP YOUR CAR NOT RUNNING OR STORE IT.

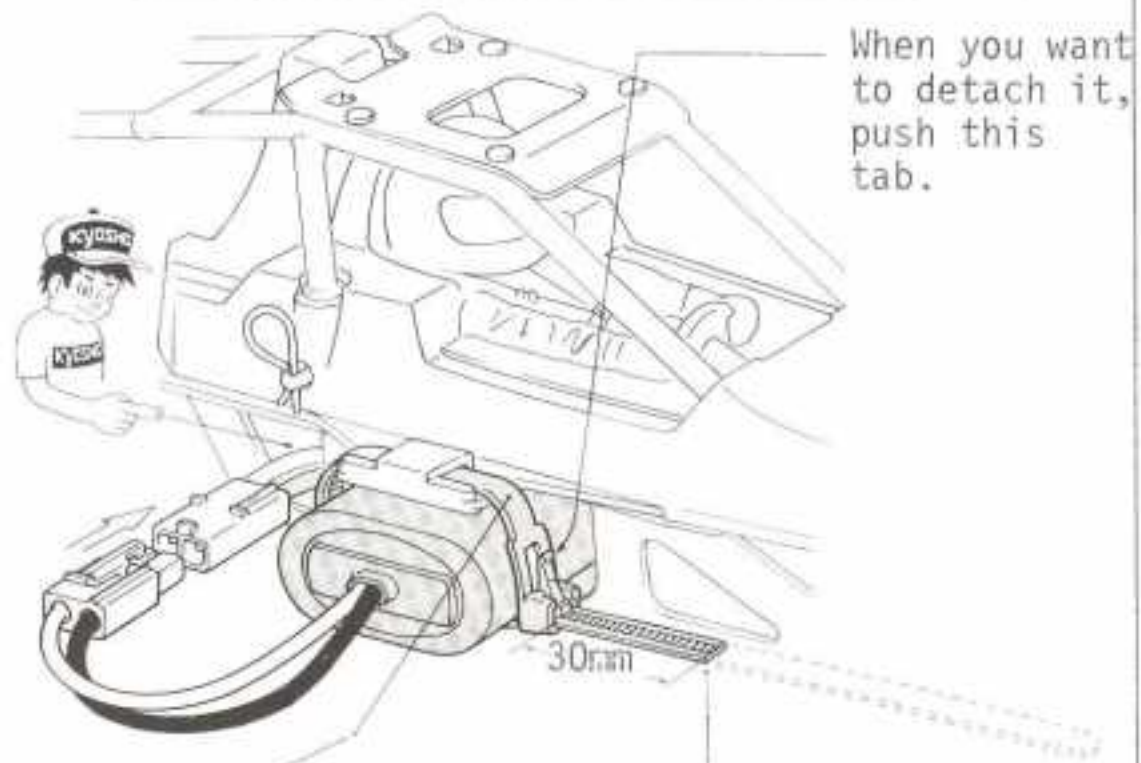

When you want to detach it, push this tab.

⑩① Ni-Cad Strap

Cut off the strap leaving 30mm excessive end after fastening it firmly.

KYOSHO



For maximum performance of car, a high performance battery is recommended. (Not included in kit)

EXPLODED VIEW OF FRONT AND REAR DIFFERENTIAL

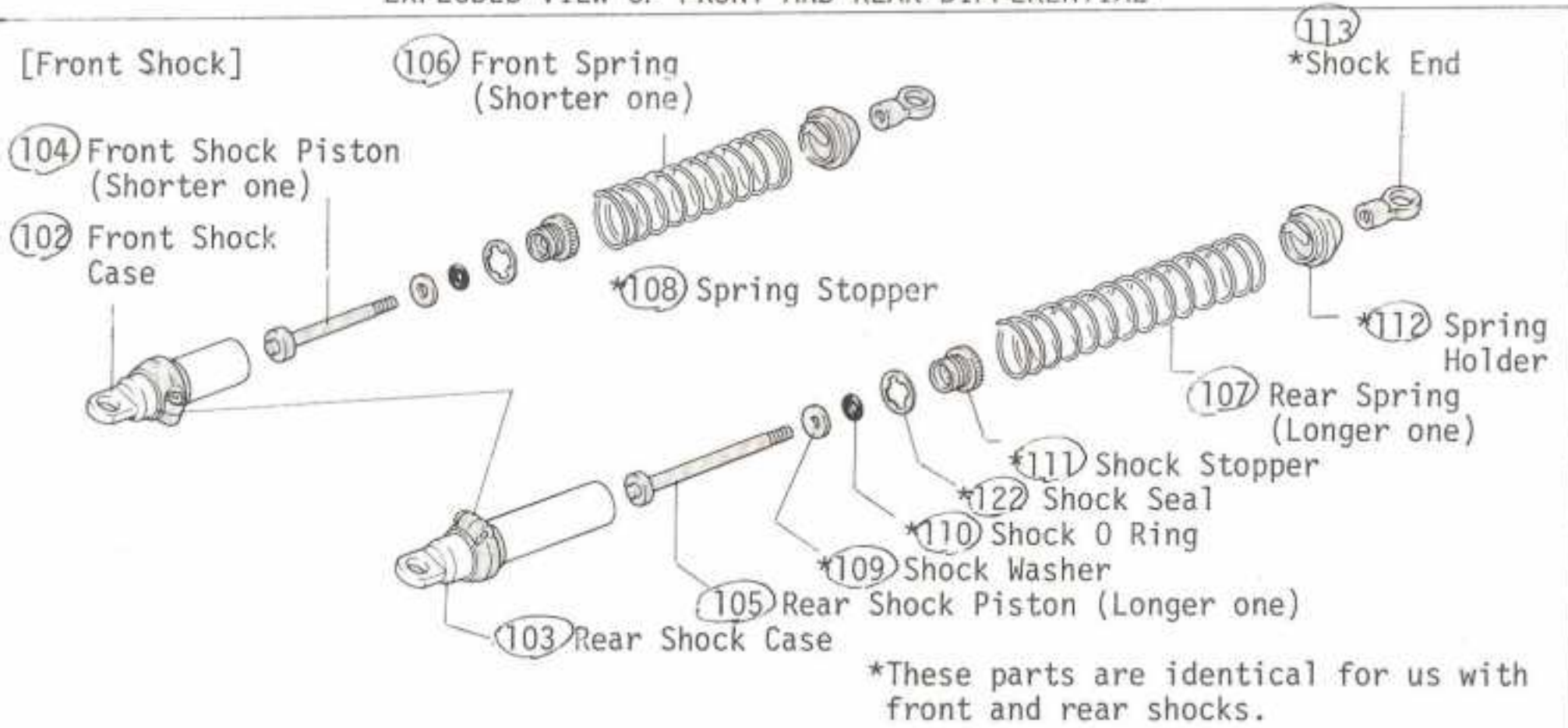

SETTING GUIDE

[Recommend to fix the front stabilizer]

1. Steering characteristic is sensitivity in running.
2. Flat race track.
3. Hard race track and bad gripping.

[Not recommend to fix the front stabilizer]

1. Steering characteristic is insensitivity in running.
2. Bumpy race track.

[How to Fix the Front Stabilizer]

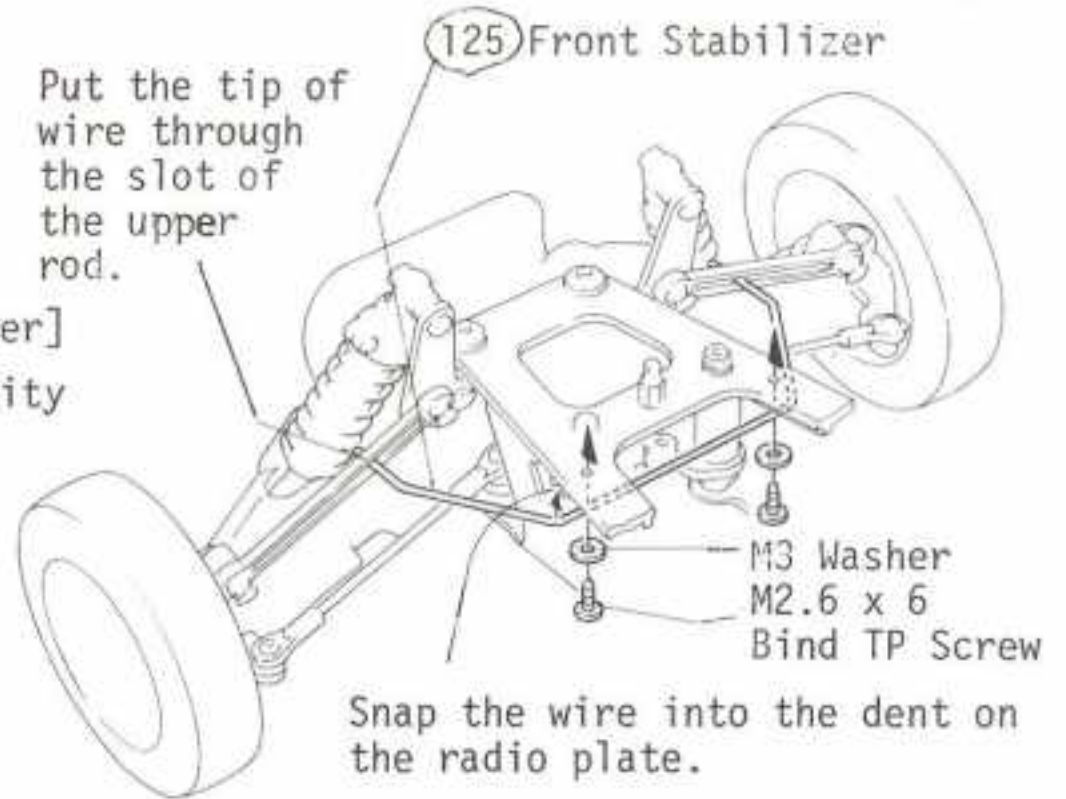

[Adjustment of Shock Size]

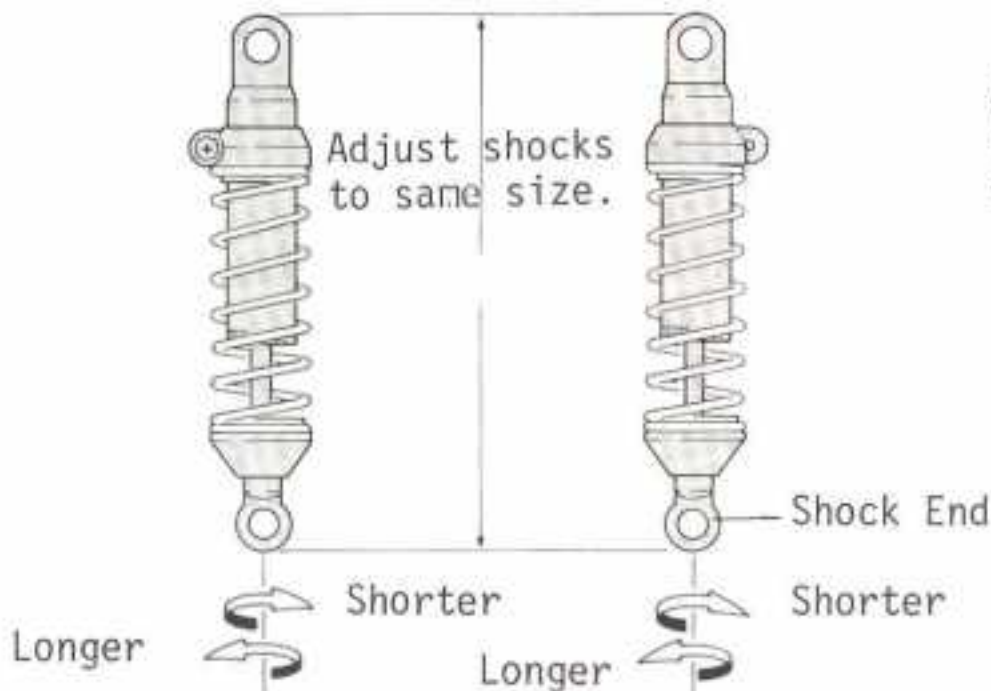

Adjust the shocks so that both front shocks and both rear shocks are exactly the same length.

[Customizing the Tires]

*Rear Tire

(1) You can increase performance for various track conditions by trimming the knobs of the rear tires. Consult the chart below.

Track	Amount of Trim
Grass	1/2
Concrete	2/3
Sand	None
Hard Dirt	1/3
Soft Dirt	None

Trim the knobs.

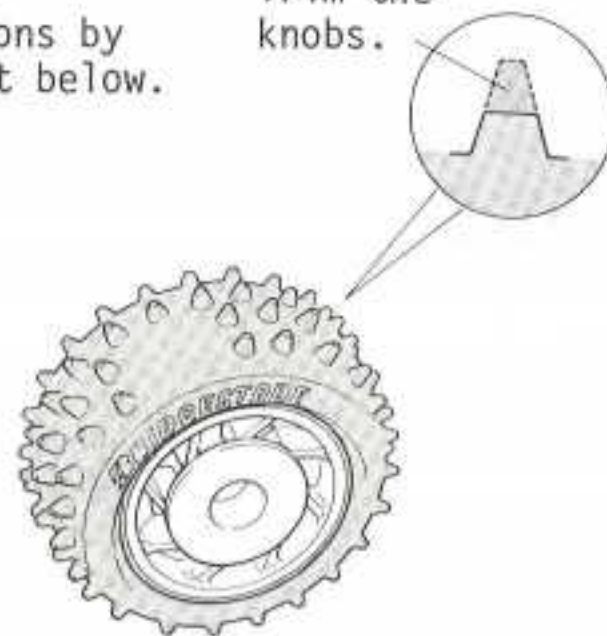

(2) Besides these items, tires for hard and soft road surfaces are available from the "Option House" kit.

*Front Tire

For improving the road holding grip of front tire, an optional one with deeper tread pattern is also sold in the market.

[Adjustment of Shock Oil and Sprint]

- Front (With lighter damper oil, or by loosening the spring tension) . . . The steering becomes more effective.
- Front (With heavier shock oil, or by hardening the spring tension) . . . The steering becomes less effective.
- Rear (With lighter shock oil, or by loosening the spring tension) . . . The traction increases.
- Rear (With heavier shock oil, or by hardening the spring tension) . . . The traction decreases.

[Gear Ratio and Motor]

Pinion Gear	14T	15T	16T	17T	18T	19T	20T
Gear Ratio	8.8	8.2	7.7	7.3	6.9	6.5	6.2
	240S, 240 SB						
Le Mans Motor			360Gold, 360PT				
Motor	480S, 480T, 480Gold						

[Optional Racing Clutch]

This is a centrifugal clutch for the electric buggy car with a function of the torque limiter. You can control your car much more easily on the slippery road surface with this optional item employed. Also the device will protect the motor and the gear train from percussion.

*There are three kinds of racing clutches available. Please refer to the list of optional parts on page 29.

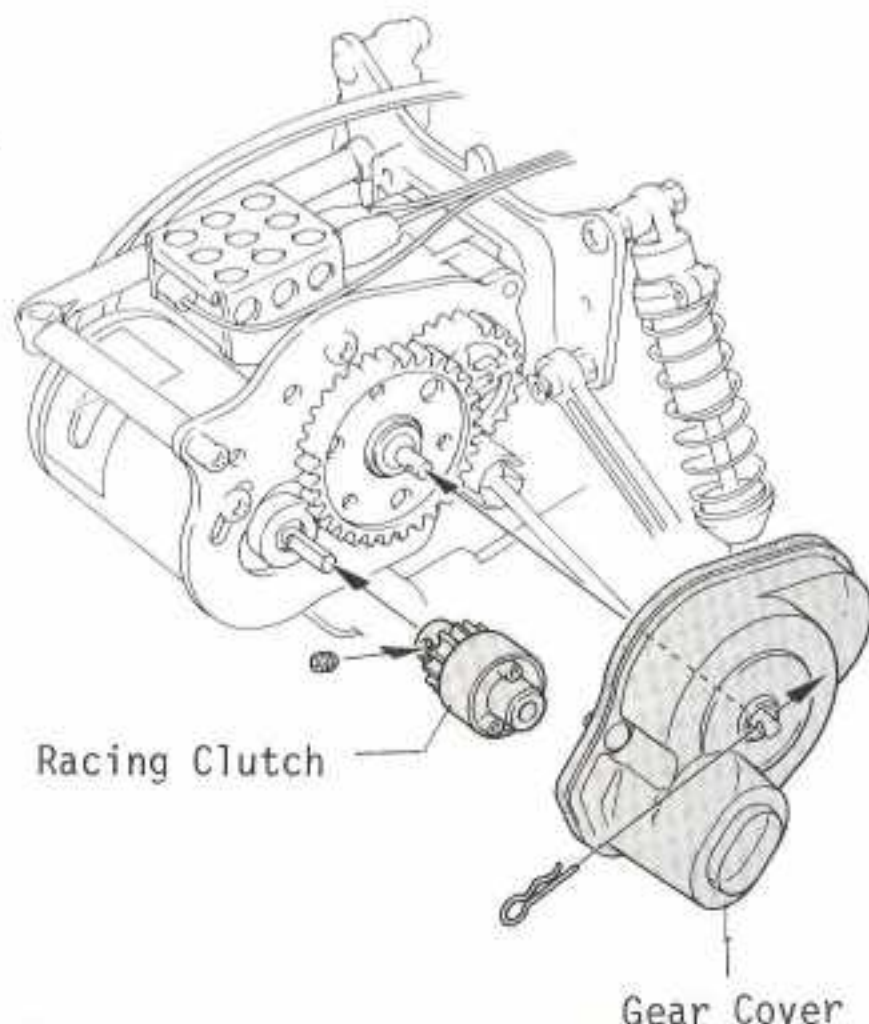

RUNNING THE ULTIMA

The same battery powers the radio and motor. As soon as the car starts to slow down, recharge the battery. Otherwise you will quickly lose control.

It seems I've lost the steering control!

What! You, handless chicken.



After running, always remove the battery from the car.

Ni-Cad Battery



[Check Before Every Run]

1. Check to see if all bolts and nuts are tightened firmly.
2. Check to see Ni-Cad battery is fully charged.
3. Check to see if the steering and speed control is in proportion to your control of the transmitter.
4. Check to see that all wiring is properly insulated.
5. Check to see if parts are moving smoothly.

[Operating Procedures]

1. Turn transmitter switch on.
2. Switch on the receiver.
3. Check to see if the radio system is working properly.

NOTE: When turning off the switches, turn off the receiver first then transmitter. Otherwise, the servos may be left in a position other than neutral.

[Trouble Shooting If the Car Does Not Start]

1. Poor contact of connectors of batteries, connector, and speed control
2. Check to see if the Ni-cad battery is fully charged.
3. Check to see shortage of battery power for the transmitter.
4. Signal jamming from other radios.

KEY NUMBERS FOR PARTS

No.	Parts Name	Q'ty	No.	Parts Name	Q'ty	No.	Parts Name	Q'ty
①	Main Gear	1	59	Speed Control Contact Point	2	114	BEC Connector	1
②	Diff. Gear	1	60	Speed Control Stud	1	115	Speed Control Rod	1
③	Bushing Collar	2	61	Speed Control Spring	1	116	Motor (RS-540)	1
④	Bevel Gear (A)	2	62	PC Board	1	117	Side Guard	1
⑤	Bevel Gear (B)	2	63	Radio Plate	1	118	Main Chassis	1
⑥	Bevel Shaft	2	64	Connector	1	119	Oil	1
⑦	Joint	2	65	Antenna Post	1	120	Resistor	1set
⑧	10 ϕ x 14 Bushing	2	66	Regulator	1	121	Drive Washer	2
⑨	Gear Box (R)	1	67	Servo Stay	4	122	Shock Seal	4
10	Motor Plate	1	68	Body Stopper (R)	1	123	Shock Wrench	1
11	Counter Gear Shaft	1	69	Heat Sink (A)	1	124	Strap (S)	2
12	2 ϕ x 11 Pin	2	70	Heat Sink (B)	1	125	Front Stabilizer	1
13	5 ϕ x 10 Bushing	6	71	Center Gear Shaft	1	126	Allen Wrench (2)	1
14	Gear Box (L)	1	72	Center Gear	1	127	Counter Gear	1
15	E Ring (E-4)	1	73	Center Gear Bushing	1	128	Final Pinion	1
16	Rear Shock Stay	1	74	O Ring	1	129	Rear Axle Stopper	1
17	Rear Bulk Head	1	75	Allen Wrench (1.5)	1	130	Body Hook	1
18	Upper Rod	4	76	Pinion Gear (15T)	1	131	Side Guard Collar	1
19	5.8 ϕ Ball	12	77	Gear Cover	1	132	Body Stopper (L)	1
20	Gear Box Hatch	1	78	Gear Cover Seal	1	133	Body Pin	3
21	Rear Hub	2	79	Hook Pin	4			
22	Rear Wheel Shaft	2	80	Front Tire	2			
23	Sus. Shaft (A)	2	81	Rear Tire	2			
24	E Ring (E-2.5)	8	82	Front Wheel (1)	2			
25	Rear Sus. Arm	2	83	Front Wheel (2)	2			
26	Swing Shaft	2	84	Rear Wheel (1)	2			
27	Sus. Shaft (B)	2	85	Rear Wheel (2)	2			
28	Shock Bush	4	86	Rear Wheel (3)	2			
29	M3 Plastic Nut	6	87	4 ϕ x 8 Plastic Bushing	4			
30	Front Hub	2	88	M4 Plastic Nut	2			
31	King Pin	2	89	Double Sided Tape	1			
32	Knuckle Arm (R)	1	90	Antenna Pipe	1			
33	Knuckle Arm (L)	1	91	Body	1			
34	Front Wheel Shaft	2	92	Decal	1			
35	Front Shock Stay	1	93	Roll Bar	1			
36	Front Bulk Head	1	94	Roll Bar Plate	1			
37	Sus. Shaft (C)	2	95	Roll Cage (R)	1			
38	Front Sus. Arm	2	96	Roll Cage (L)	1			
39	Sus Shaft (D)	2	97	Roll Cage Joint	2			
40	Front Shock Bumper	1	98	Roll Cage Stopper	4			
41	Ball Nut	2	99	E Ring (E-3)	6			
42	Servo Saver (A)	1	100	Wing	1			
43	Servo Saver (B)	1	101	Ni-Cad Strap	2			
44	Servo Saver (C)	1	102	Front Shock Case	2			
45	Servo Saver (D)	1	103	Rear Shock Case	2			
46	M2.6 Pivot Ball	1	104	Front Shock Piston	2			
47	Center Rod	1	105	Rear Shock Piston	2			
48	Servo Saver Shaft	2	106	Front Spring	2			
49	Servo Saver Collar	2	107	Rear Spring	2			
50	Ball End (L)	4	108	Spring Stopper	4			
51	Tie Rod	2	109	Shock Washer	4			
52	Ball End (S)	2	110	Shock O Ring	4			
53	Steering Rod	1	111	Shock Stopper	4			
54	2.6 ϕ Collar	2	112	Spring Holder	4			
55	Speed Control Nut	1	113	Shock End	4			
56	Speed Control Horn	1						
57	Speed Control Pivot	1						
58	Motor Cord	1set						

PURCHASING PARTS FOR YOUR KIT

You can purchase replacement and optional parts for your kit. All of the part identified by key numbers (see page for a complete list) are usually not available singularly, but we offer these parts in convenient parts "packs" which can be purchased separately. To figure out which parts pack you need, find the key number for that part within the manual. Then consult our parts pack guide, below. When referring to the parts you need, always use the parts pack number. For instance, if you need a counter gear shaft (Key #11) ask your dealer for Kyosho Parts Pack UM-5 (Gear Shaft Set).

<u>Parts Pack #</u>	<u>Description</u>	<u>Includes These Key Numbers</u>
OT- 5	Joint	7 x 2
OT- 6	Swing Shaft	26 x 2
OT-18	Rear Shaft	22 x 2
OT-19	Drive Washer	121 x 4
OT-24	Pinion Gear (15T)	76 x 1
OT-28	Differential Gear Set	6 x 2 4 5 x 4
OT-29	O Ring	74 x 10
OT-32	5.8ø Ball	19 x 10
OT-33	Ball Nut (M2.6)	41 x 10
OT-36	M2.6 Pivot Ball	46 x 10
OT-37	Cord Set	66 x 1 58 x 1set
OT-39	E Ring (E-2.5)	24 x 10
OT-58	Wing	100 x 1
OT-66	Low Profile Tire (Rear)	81 x 2
OT-72	Registor Heat Sink	69 70 x 1
SC-26	Front Tire	80 x 2
SC-46	Double Sided Tape	89 x 1
SC-67	Speed Control Set	55 56 57 60 61 62 x 1 59 x 2
SC-78	Speed Control PC Board	82 x 1
SC-79	Speed Control Contact Point	59 x 2
SC-89	Tie Rod	51 x 2 46 50 x 4
SC-105	Resistor	120 x 1set
EP-22	Hook Pin	79 x 5
EF-26E	Connector	64 x 1
EF-39	Ni-Cad Strap	101 x 6
EF-37	Strap (S)	133 x 6
SD-79	Antenna Pipe	90 x 5
KC-20	E Ring (E-4)	15 x 4
CB-72	E Ring (E-3)	99 x 4
AB-30	Front Shock Set	102 104 106 108 109 110 111 112 113 x 2 122 x 4 123 x 1
AB-31	Rear Shock Set	103 105 107 108 109 110 111 112 113 x 2 122 x 4 123 x 1
1887	Shock Seal (M)(10ø)	122 x 10
1889	Body Pin	133 x 5
UM- 1	Gear Set	1 2 72 127 128 x 1
UM- 2	Bushing Set	73 x 1 3 8 x 2 13 x 6
UM- 3	Gear Box	9 14 x 1
UM- 4	Motor Plate	10 x 1
UM- 5	Gear Shaft Set	11 71 x 1 12 x 2
UM- 6	Shock Stay Set	16 35 x 1
UM- 7	Sus. Shaft Set	23 27 37 39 x 2
UM- 8	Front Shaft Set	31 34 x 2
UM- 9	Rod Set	47 35 115 125 x 1 52 x 2
UM-10	Collar Set	48 54 x 2
UM-11	Upright Set	32 33 x 1 21 30 x 2
UM-12	Bulk Head Set	17 36 77 78 129 x 1
UM-13	Suspension Arm Set	25 38 x 2

Parts Pack #	Description	Includes These Key Numbers
UM-14	Servo Saver Set	20 42 43 44 45 65 130 x 1 49 x 2 18 28 29 67 87 88 x 4
UM-15	Radio Plate	63 x 1
UM-16	Body Set	68 93 94 95 96 117 131 132 x 1 97 x 2 98 x 4
UM-17	Wheel Set	82 83 84 85 86 x 2
UM-18	Body	91 x 1
UM-19	Decal (Ultima)	92 x 1
UM-20	Main Chassis	119 x 1
UM-21	Front Bumper	40 x 1
UM-22	Screw Set	Screw, Nut, Wrench Set (w/o Plastic Nut)

* OPTIONAL PARTS *

1901	Ball Bearing (5ø x 10)	2pcs. For Rear Hub & Gear Box
1903	" (4ø x 8)	2pcs. For Center Gear, Front Wheel
1911	" (8ø x 14)	2pcs. For Differential Gear
W-5031	Low Profile Tire, Allround Type (For Hard Truck)	
W-5032	Low Profile Tire, High Grip (For Soft Truck)	
OT-51	Pinion Gear (14T)	Gear Ratio 8 : 1
OT-52	" (16T)	" 7.7 : 1
OT-53	" (17T)	" 7.3 : 1
UM-23	" (18T)	
UM-24	" (19T)	
UM-25	" (20T)	
1951	Shock Oil Set (S,M,H.)	3 Different Weight
LM-15	Cooling Plate	For Le Mans Motor
OT-64	Special Wing	Silvered
SC-90	Front Tire	High Grip Type
W-5021	Low Profile Wheel	Silver
W-5044	Racing Clutch (14T)	
W-5046	" (16T)	
W-5048	" (18T)	
W-5001	Pressure Oil Shock (S)] Use with UM-26 Special Shock Stay
W-5002	" (L)	
OT-76	Hard Final Pinion Gear	Need D-cut on the shaft
1990	Regulator	Stabilized power source for the receiver
EF-103	Racing Wire	4ø Silicon Cord
1863	Sponser Sticker	Decal with sponser mark
UM-26	Special Shock Stay	For pressure oil shock made by glass
UM-27	Special Chassis	2mm thickness
UM-28	Motor Guard (Ultima)	
W-5061	Universal Swing Shaft	Wheel Shaft, Swing Shaft Set
1952	Differential Oil	Use when willing to harden the differential gear
W-5005	Special Rod Set	Upper arm/Tierod adjustment

1 ASSEMBLY OF DIFFERENTIAL GEAR

M2 x 10 TP Screws(4)



③ Bushing Collars (Black Color)(2)



④ Bevel Gears(A)(2)

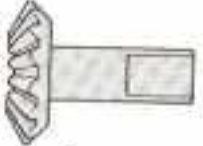

⑤ Bevel Gears(B)(2)



⑥ Bevel Shaft (1)



2 INSTALLATION OF JOINT

M4 x 4 Set Screws(2)



M5 Washers (2)



⑦ Joints (2)

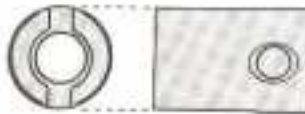

⑧ 10φ x 14φ Bushings (2) (Gold Color)

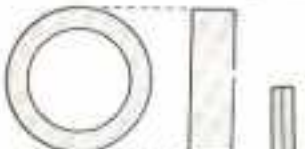

⑮ Allen Wrenchs (2)

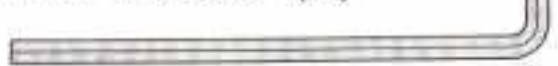

3 INSTALLATION OF COUNTER GEAR

⑪ Counter Gear Shaft (1)



⑫ 2φ x 11 Pin (1)



⑬ 5φ x 10φ Bushing(1)



⑫ Counter Gear (1)



4 INSTALLATION OF FINAL PINION GEAR

⑫ 2φ x 11 Pin (1)



⑫ Final Pinion(1)



5 ASSEMBLY OF GEARBOX

M3 x 8 Bind TP Screw(1)



M3 x 33 Screw (3)



⑬ 5φ x 10φ Bushing (1)



⑮ E Ring (E-4) (1)



6 INSTALLATION OF REAR SHOCK STAY

M3 x 8 Bind TP Screws (4)

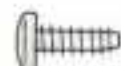

M3 x 16 Screws(2)



M3 x 15 Flat Head Screws (2)



M3 Nuts (6)



⑰ 5.8φ Balls (4)



7 INSTALLATION OF GEARBOX

M4 x 8 Truss Screws(6)



M3 x 35 Bind Screw (1)



8 INSTALLATION OF REAR HUB

⑬ 5φ x 10φ Bushings(4)



⑮ Sus. Shaft (A)(2) (Silver Color)



⑮ E Rings(E-2.5)(2)

⑮ Sus. Shafts (B)(2)



9 INSTALLATION OF REAR SUSPENSION

M3 x 12 Flat Head Screws (2)



M4 x 8 Truss Screws(2)



⑮ Rear Wheel Shafts (2)



10 FILLING SHOCK WITH OIL

109 Shock Washers (4) (Assembled)



110 Shock O Rings (4) (Assembled)



113 Shock Ends (4) (Assembled)



122 Shock Seals (4)



11 INSTALLATION OF REAR SHOCK

M3 x 12 Flat Head Screws (2)



⑰ 5.8φ Balls (2)



⑮ Shock Bushes(2)



⑮ M3 Plastic Nuts (2)



12 INSTALLATION OF FRONT KNUCKLE ARM

⑰ E Rings (E-3)(2)



⑮ King Pins (2)



⑮ Front Wheel Shafts (2)

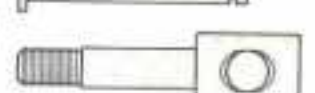

⑮ M2.6 Pivot Balls (2)



13 INSTALLATION OF FRONT SHOCK STAY

M3 x 8 Bind TP Screws (2)

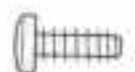

M3 x 16 Screws (2)



M3 x 15 Flat Head Screws (2)



M3 Nuts (6)



⑰ 5.8φ Balls (4)



14 INSTALLATION OF FRONT SUS. ARM

⑮ E Rings(E-2.5)(6)





⑮ Sus. Shafts (C) (2) (Black Color)





⑮ Sus. Shafts (D)(2)







15 INSTALLATION OF FRONT BULK HEAD

- M3 x 12 Flat Head Screws (2) 
- M4 x 8 Truss Screws (2) 
- M4 x 10 Flat Head Screws (2) 

16 INSTALLATION OF FRONT SHOCK

- M3 x 16 Screws (2) 
- 28 Shock Bushes (2) 
- 29 M3 Plastic Parts (2) 



17 ASSEMBLY OF SERVO SAVER

- M2.6 x 6 Bind Screw (1) 
- M2.6 Nuts (4) 
- 4) Ball Nut (1) 
- 46 M2.6 Pivot Balls (2) 
- 47 Center Rod (1) 





18 INSTALLATION OF SERVO SAVER

- M3 x 35 Bind Screws (2) 
- M3 Nuts (2) 
- M3 Washers (2) 
- 48 Servo Saver Shafts (2) 
- 49 Servo Saver Collars (2) 

19 INSTALLATION OF TIE ROD

- 50 Ball Ends (L) (4) 
- 51 Tie Rods (2) 

21 INSTALLATION OF STEERING ROD

- M3 x 8 Bind TP Screws (2) 
- M3 Washers (2) 
- 52 Ball Ends (S) (1) 
- 53 Steering Rod (1) 





22 INSTALLATION OF STEERING SERVO

- M3 x 8 Bind TP Screws (2) 

23 ASSEMBLY OF SPEED CONTROL

- M2.6 x 6 Bind Screw (1) 
- M2.6 x 10 Bind Screw (1) 
- M3 Nuts (Gold Colors) (2) 
- 41 Ball Nut (1) 
- 54 2.6ø Collar (1) 
- 55 Speed Control Nut (1) 
- 57 Speed Control Pivot (1) 
- 59 Silver Contact Points (2) 
- 67 Speed Control Stud (1) 
- 61 Speed Control Spring (1) 

24 INSTALLATION OF BATTERY CONNECTOR

- M3 x 12 Screws (Silver Color) (2) 
- M2.6 x 6 Bind TP Screw (1) 
- M3 x 8 Bind TP Screw (1) 
- M3 Nuts (Silver Color) (2) 
- 130 Body Hook (1) 

26 INSTALLATION OF BATTERY CONNECTOR

- M3 Nuts (Gold Collar) (2) 



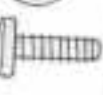



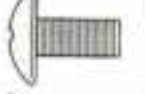

27 INSTALLATION OF SPEED CONTROL SERVO

- M3 Washers (2) 
- M3 x 8 Bind TP Screws (4) 



28 SPEED CONTROL LINKAGE

- M2.6 Washers (2) 
- 52 Ball End (S) (1) 
- 115 Speed Control Rod (1) 



29 INSTALLATION OF RADIO PLATE

- M4 x 8 Truss Screws (2) 
- M4 x 10 Flat Head Screws (2) 
- M3 x 6 Bind Screws (4) 
- M2.6 x 12 TP Screws (2) 
- M3 Nuts (4) 
- 27 M3 Plastic Nuts (2) 
- 132 Body Stopper (R) (1) 
- 68 Body Stopper (L) (1) 



30 FIXING OF REGISTER

- M3 x 6 Bind Screws (2) 
- M3 Nut (1) 
- 7 Center Gear Shaft (1) 

31 INSTALLATION OF CENTER GEAR

- M4 Washers (2) 
- 74 O Ring (Black Rubber)(1) 
- 73 Center Gear Bushing(1) 

32 INSTALLATION OF MOTOR

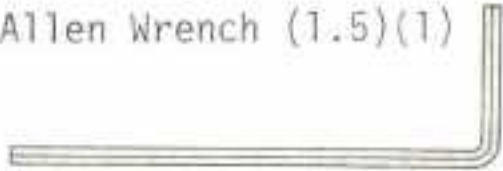
- M3 x 6 Bind Screws(2) 
- M3 x 3 Set Screw (1) 
- 75 Allen Wrench (1.5)(1) 



33 INSTALLATION OF GEAR COVER

- M2.6 x 12 TP Screws (2) 
- 54 2.6φ Collar (1) 
- 131 Side Collar (1) 
- 79 Hook Pin (1) 



34 FABRICATION OF TIRE AND WHEEL

- M2 x 8 TP Screws (8) 

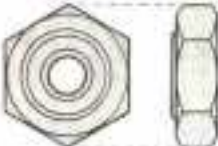
35 MOUNTING OF TIRE

- M4 Nylon Nuts (2) 
- 87 4φ x 8φ Plastic Bushings (4) 
- 88 M4 Plastic Nuts (2) 
- 121 Drive Washers (2) 

40 ASSEMBLY OF ROLL CAGE

- M2.6 x 6 Bind TP Screws (6) 
- M2.6 x 12 Screws (4) 

41 INSTALLATION OF POLL CAGE

- 79 Hook Pins (2) 
- 98 Roll Cage Stoppers (4) 
- 99 E Rings (E-3) (4) 

42 INSTALLATION OF BODY

- 79 Hook Pin (1) 
- 133 Body Pins. (3) 



ULTIMA ULTIMA

PRINTED IN JAPAN

1/10 BUGGY RADIO CONTROL OFF ROAD RACE CAR



1/10 BUGGY RADIO CONTROL OFF ROAD RACE CAR



OFF-ROAD RACER
OFF-ROAD RACER

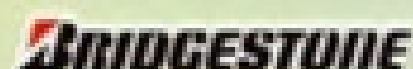
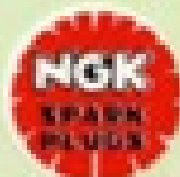
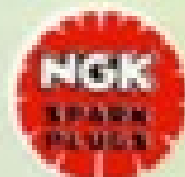
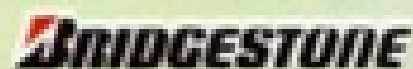

KYOSHO RACING TEAM

KYOSHO RACING TEAM

KYOSHO RACING TEAM
KYOSHO RACING TEAM