

RADIO CONTROLLED ELECTRIC POWERED SPECIAL RACING BUGGY
4WD OFF-ROAD RACER

TURBO OPTIMA MID

- *FOUR-WHEEL DRIVE BY LIGHTWEIGHT, EFFICIENT TOOTHED BELT.*
- *EXTRA-LONG SUSPENSION TRAVEL FOR TOP HANDLING.*
- *MID-SHIP MOTOR POSITION FOR BEST WEIGHT DISTRIBUTION.*
- *STRONG, LIGHT ALUMINUM-ALLOY PLATE CHASSIS.*
- *OVERSIZE PRESSURE SHOCKS. ANTI-SWAY BARS F/R.*
- *GLASS-REINFORCED SUSPENSION ARMS FOR STRENGTH WITH LIGHT WEIGHT.*
- *LOW-PROFILE HIGH-GRIP TIRES.*
- *HIGH PERFORMANCE: LIGHT WEIGHT WITH TOP SUSPENSION ACTION.*

1:10 SCALE

BATTERY: 7.2V-1200mAh

RADIO: 2ch.

MOTOR: LeMMANS 240/360 TYPE
[NOT INCLUDED]

BELT DRIVE
4WD



KYOSHO
FOR THE RADIO CONTROL MODELS

KIT No. 3136

BEFORE ASSEMBLY

* Read the instruction carefully.

You can assemble the kit more easily if you have grasped the general idea of steps and structure beforehand by reading it through to the end.

* Check the parts in the kit. Check to see if all the parts are correctly bagged as they are listed in the "List of Bagged Parts". Your thorough understanding of the assembly will enable you to build the kit without any difficulty. Check the components in the kit prior to your startings of the assembly.



Any claims for replacements or refunds for the model in the process of assembly will not.

* Lean on the marks described in the instruction.

Places to put some **LOCKTITE** ... locktite. (It will prevent the screws and nuts get loosen by vibration while running.)

Points where grease **GREASE** ... should applied. (It will reduce friction and assure smooth movements.)



Steps where you particular attention is required.

* Things need besides the kit.

Two types of radio control set are on the market, the stick type and the steering wheel type. Choose which ever you like.

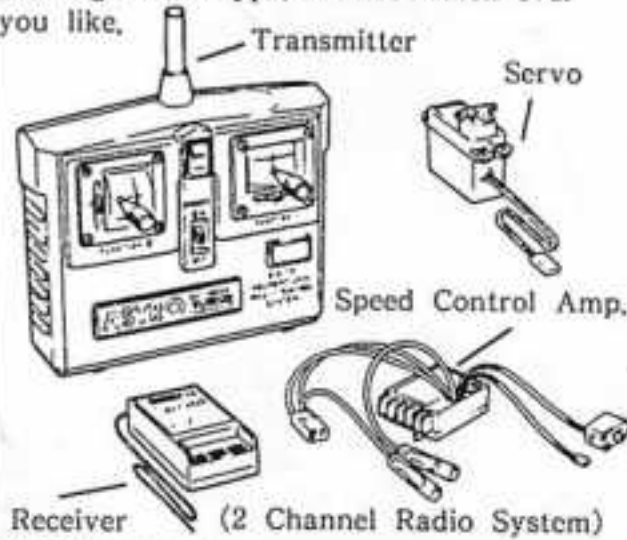

(Battery for radio System)

AA Size Battery For Transmitter ... 8 pcs
For receiver ... 4 pcs.



(Ni-Cd Battery)

"Turbo Optima Mid" is designed to use a rechargeable Ni-Cad Battery pack.

7.2V Sprint Battery and 7.2V Racing Battery are ideal for the purpose. (Motor)

The Turbo Optima Mid not come with a motor. A Le Mans series type motor is recommended for top performance.

(Charger for Ni-Cd Battery)

The Kyosho's Ni-Cd battery is of high performance. If it is charged correctly, it will operate for a considerable period of time.

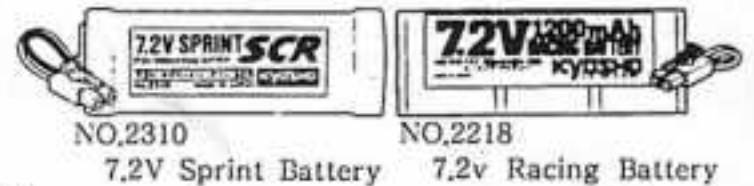

NO. W1011 SPA 240WS
Le Mans
1926 Sports H-240S
1924 Le Mans 240SB



Use one of the Chargers listed below which suits your need.

Model	Name	Time	Rate %	Features
No.2326	7.2V Power Quick Charger (DC12V)	15 (Min)	70 %	For beginners Built-in timer
No.1845	Lambda Quick Charger (DC12V)	20 (Min)	100 %	Trickle Charging auto-cut off at peak charge.

* Be well aware of the different types of screws.

1 The difference between the TP screw (short form of self-tapping screw) and the ordinary screw is....

Self Tapping Screw

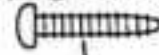

Coarser Thread

Some of them Pointed tips.

Ordinary Screw



Finer Thread

2 The kinds of screws which will be used in this instruction.

Truss Screw



Bind Screw



Flat Head Screw

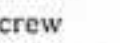

There are two kinds of thread, finer and coarser ones.

Set Screw



A hexagonal hollow in place of screw head.

Cap Screw



* Pick up the correct parts and screw. Compare the shape and size of small parts, such as screws, nuts, and washers with the attached sheet of "List of Small Parts."



* Be sure about the location and direction of parts to install.

Double-check the location and orientation of parts with the illustration before installation. When necessary, assemble the parts themselves tentatively before proceeding to the next step.



* Do not tighten the self-tapping screw too tight.

Do not use excessive force when tightening the self-tapping screws, or you may strip the thread in the plastic. It is recommended to stop tightening it when the thread part on the screw goes into the plastic part and you feel some resistance from the tightening.

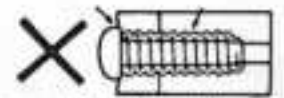
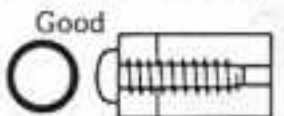

Phillips Screw Driver

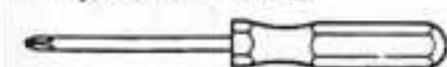

Box Driver (for M3,M4 Nut)

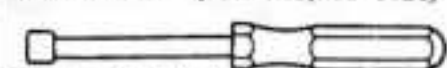

Sharp Hobby Knife



Needle Nose Plier

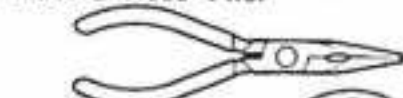

Round Cutter

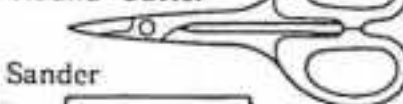

Sander



Awl



Wire Cutter

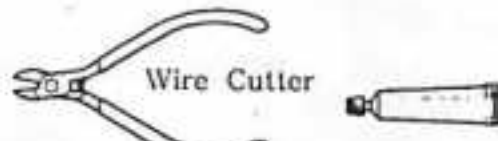

Instant Glue



Micron Line Tape



Polyca Paint



Brush



1 INSTALLATION OF JOINT



See page 20 where an exploded view of the differential gear is.



The numerical figure in the bracket is a header number of the bag, which contains the parts. Do not discard the header when you pick up a part from the bag, but keep it into the bag or tape it down.

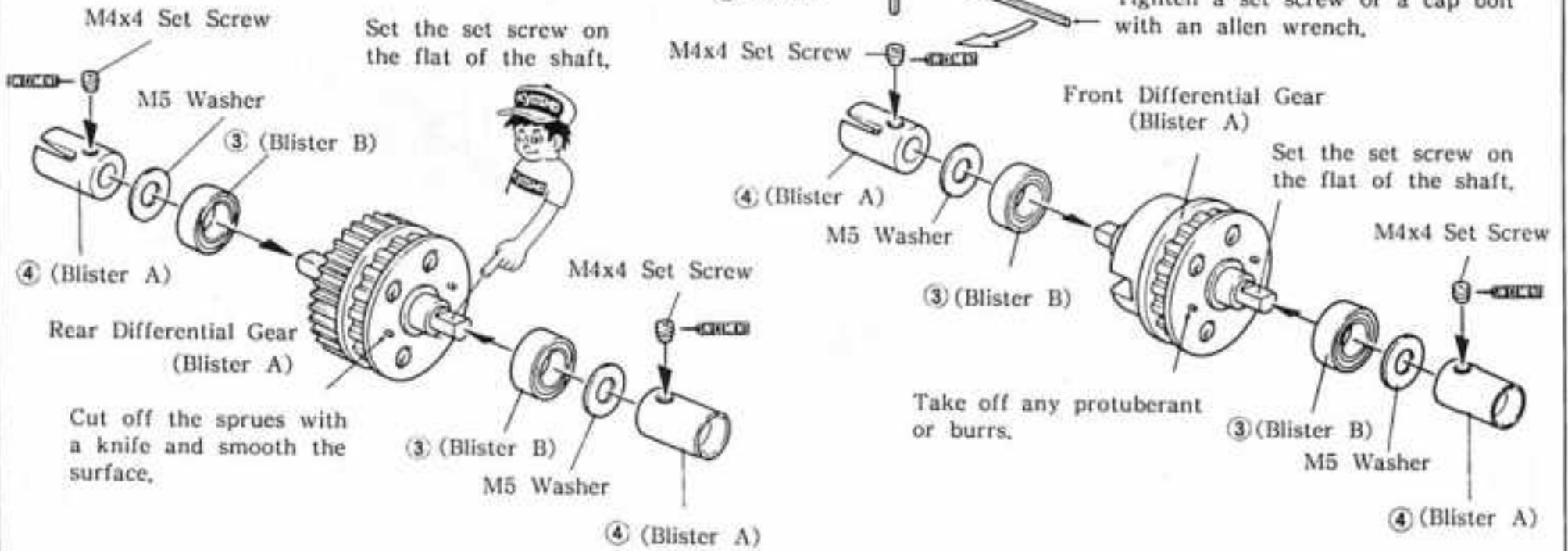

2 ASSEMBLY OF REAR GEAR BOX

Step 1

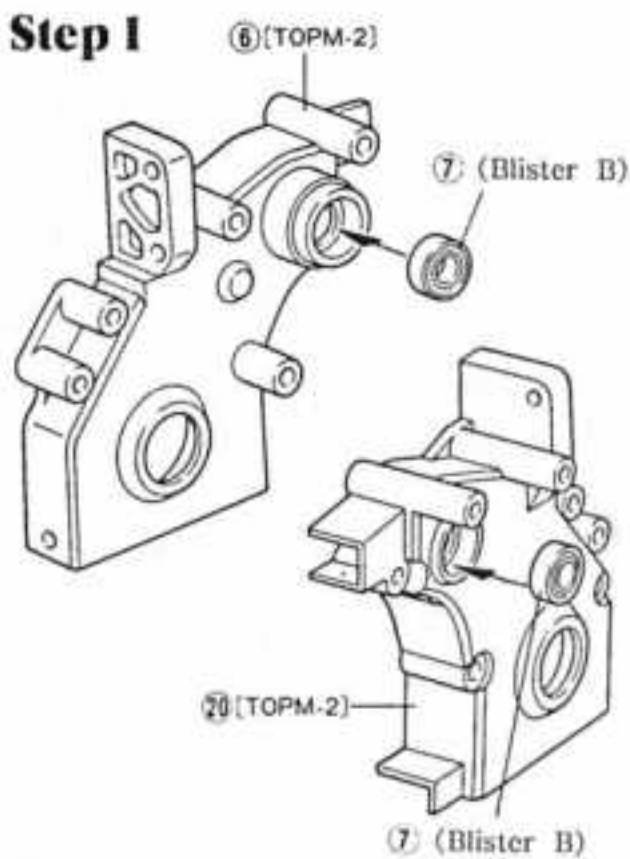

Step 2

Fix an E-ring using a pair of pliers.

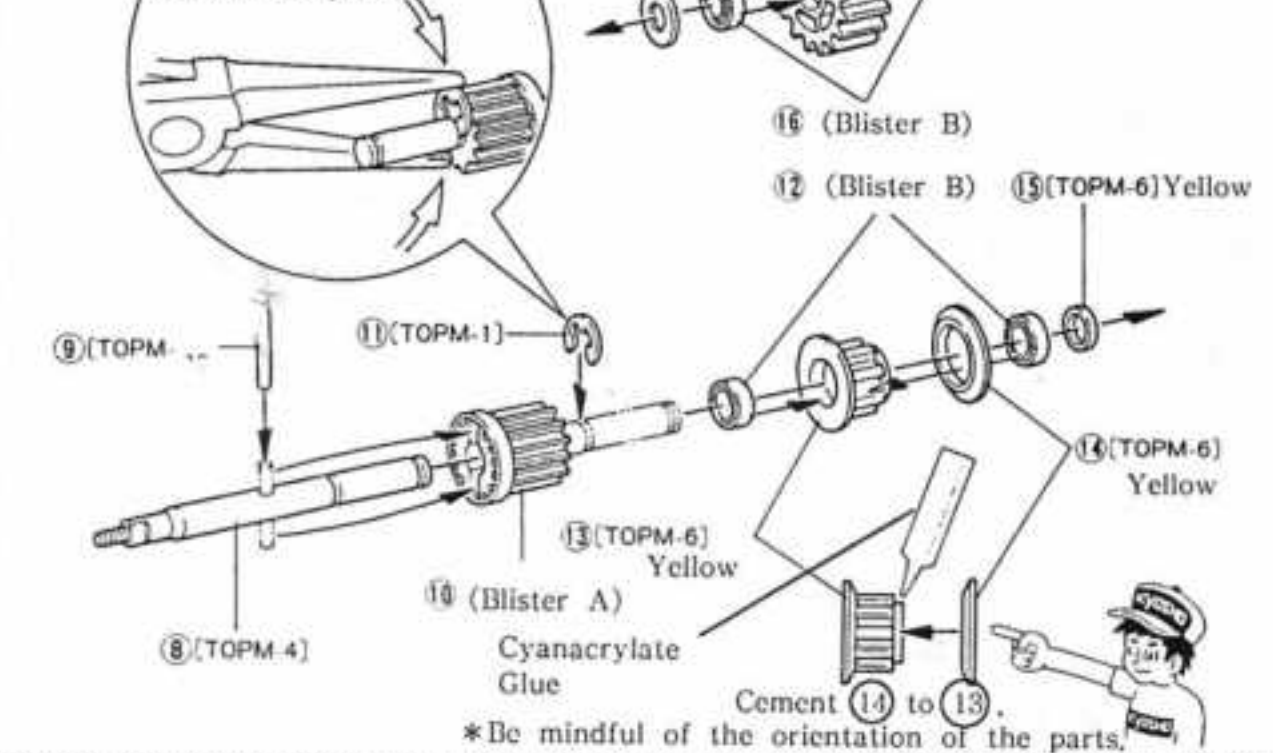

Step 3

After assembling the parts in order from (1) to (3) steps, put on (19) as illustrated below, and fasten (20) with bolts in the position.

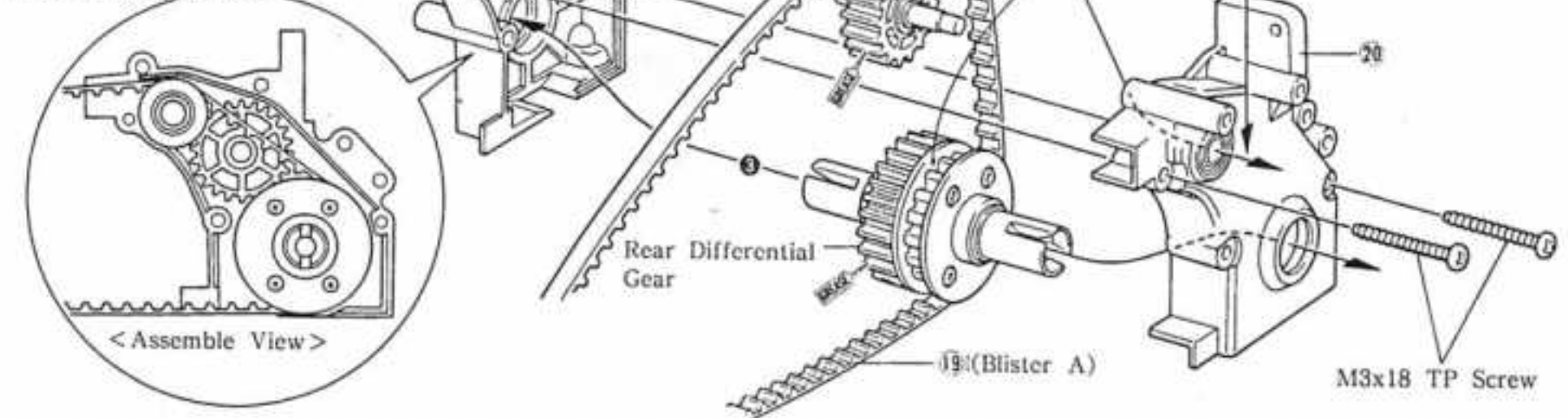

6 ASSEMBLY OF FRONT GEAR BOX

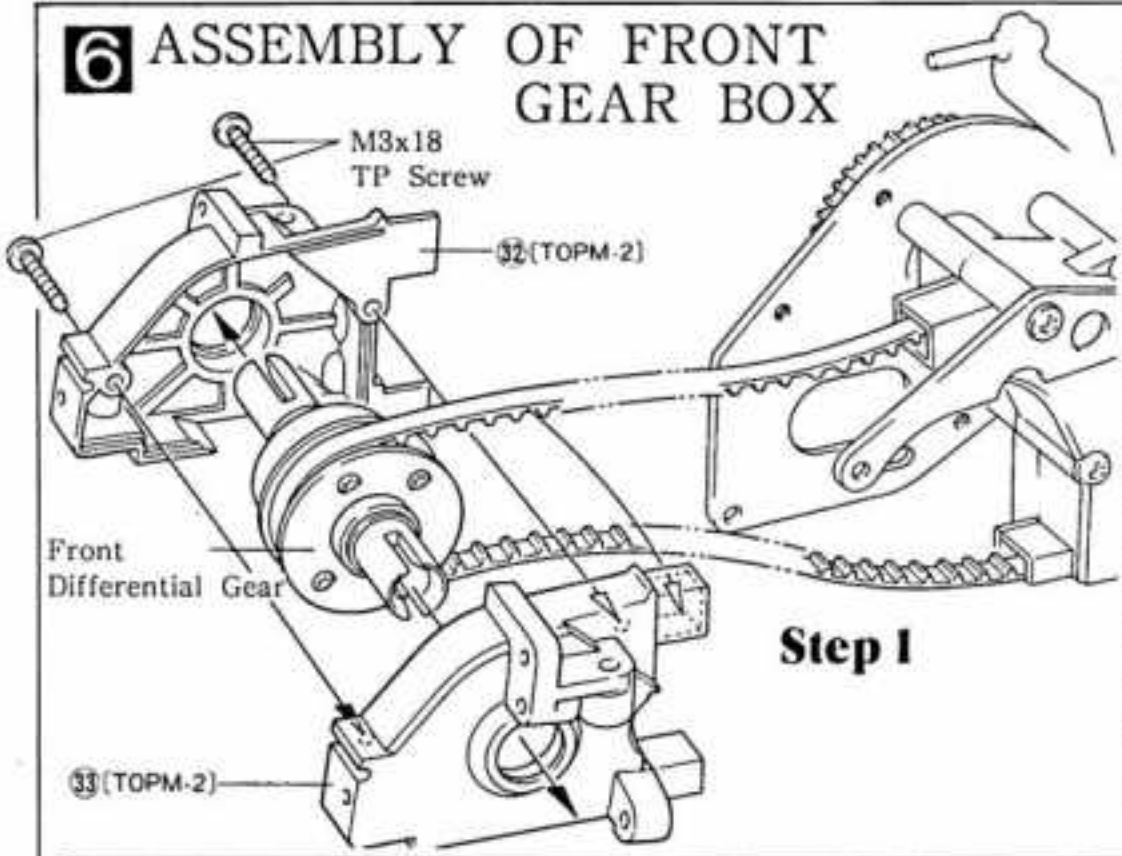

Step 2

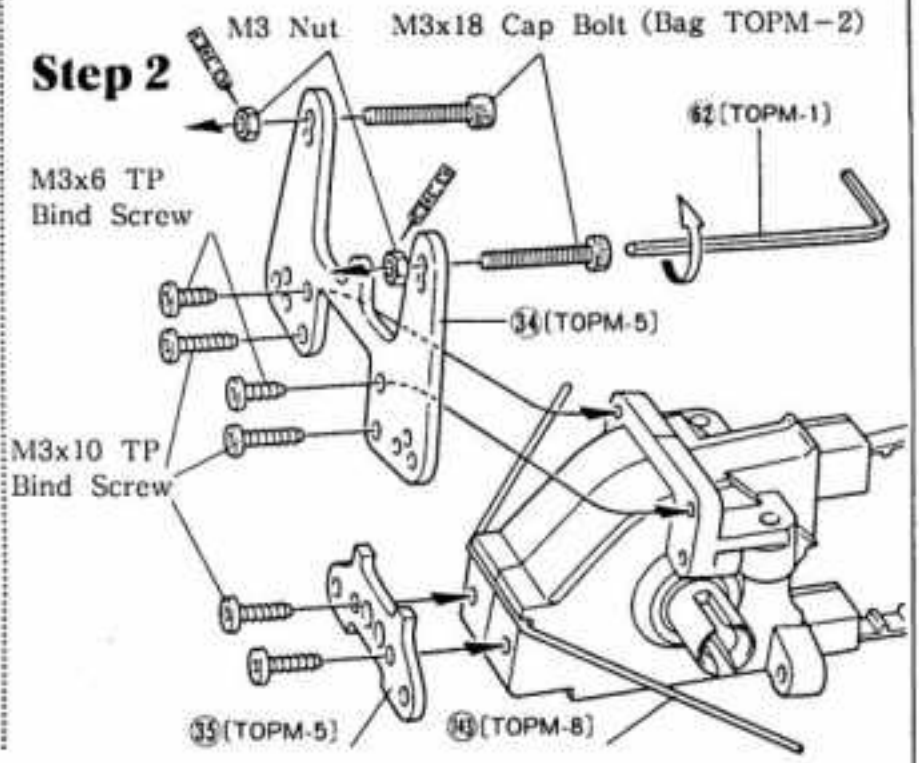

7 INSTALLATION OF GEAR BOX

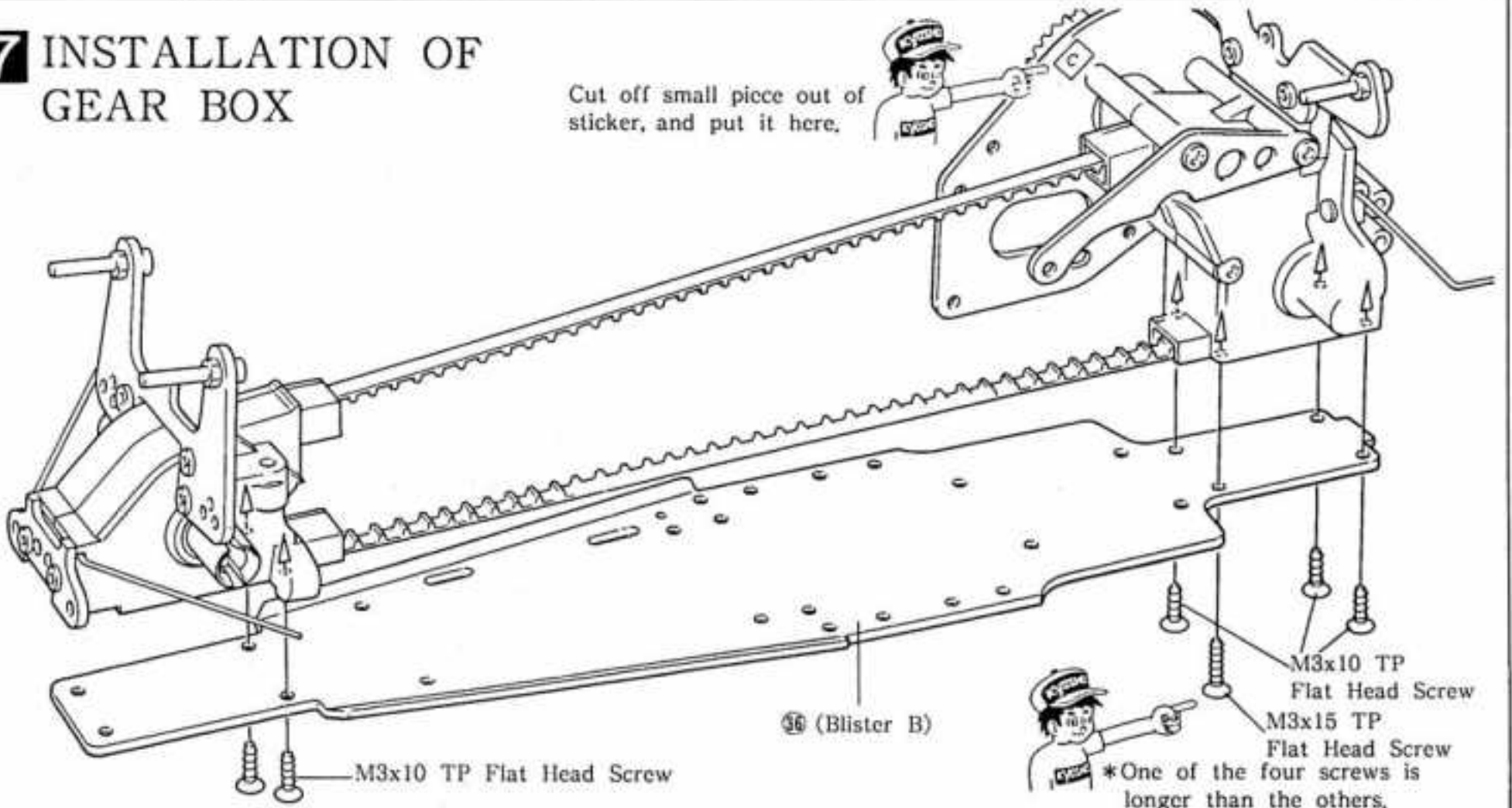

8 INSTALLATION OF BELT COVER (A)

After cutting out this part, clean the surface, particularly make it free from oily stain, where 39 is to be cemented.

Step 1

Cut off the end along the cut line.

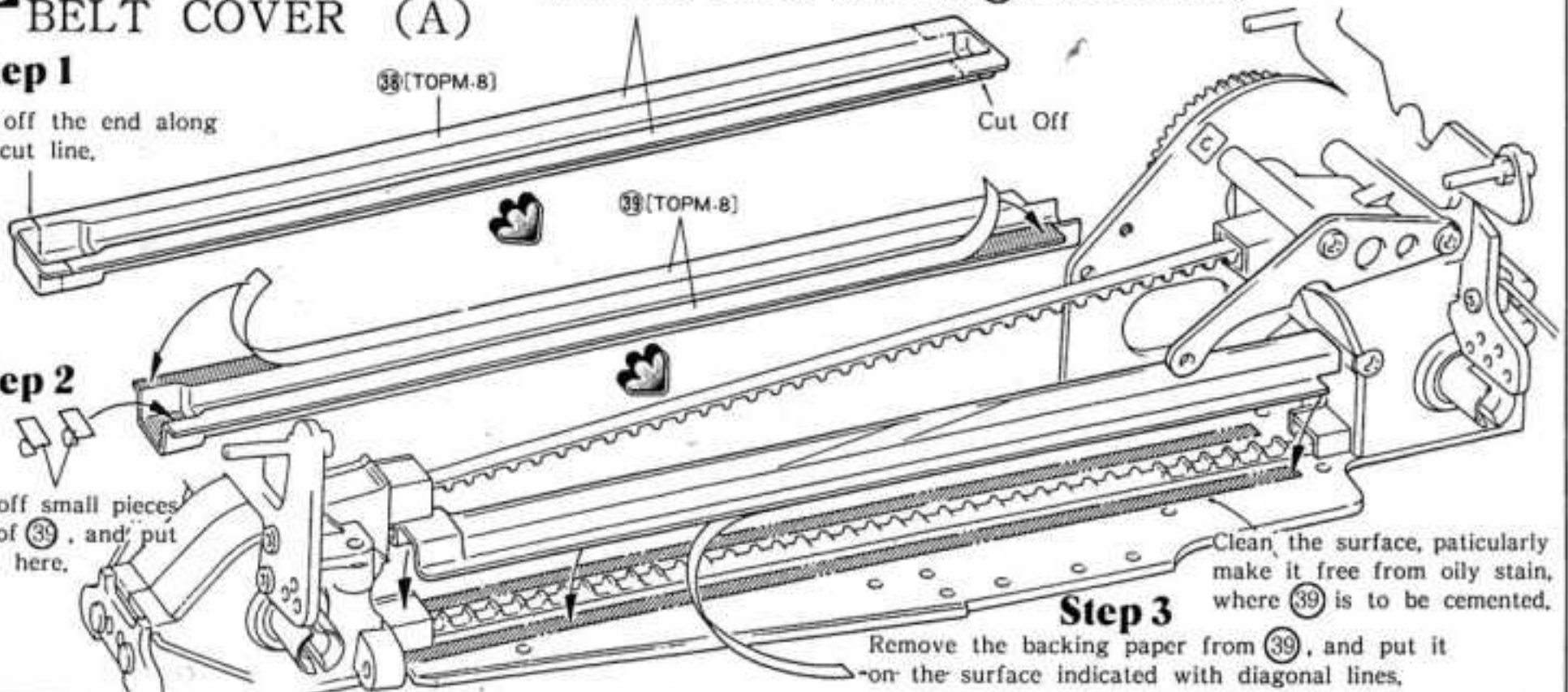

Step 2

Cut off small pieces out of 39, and put them here.

Step 3

Remove the backing paper from 39, and put it on the surface indicated with diagonal lines.

Clean the surface, particularly make it free from oily stain, where 39 is to be cemented.

9 INSTALLATION OF UPPER DECK MOUNT

Screw locking compound prevents dusts from entering through the belt cover and the chassis.

*Apply it on the shaded area on both sides.

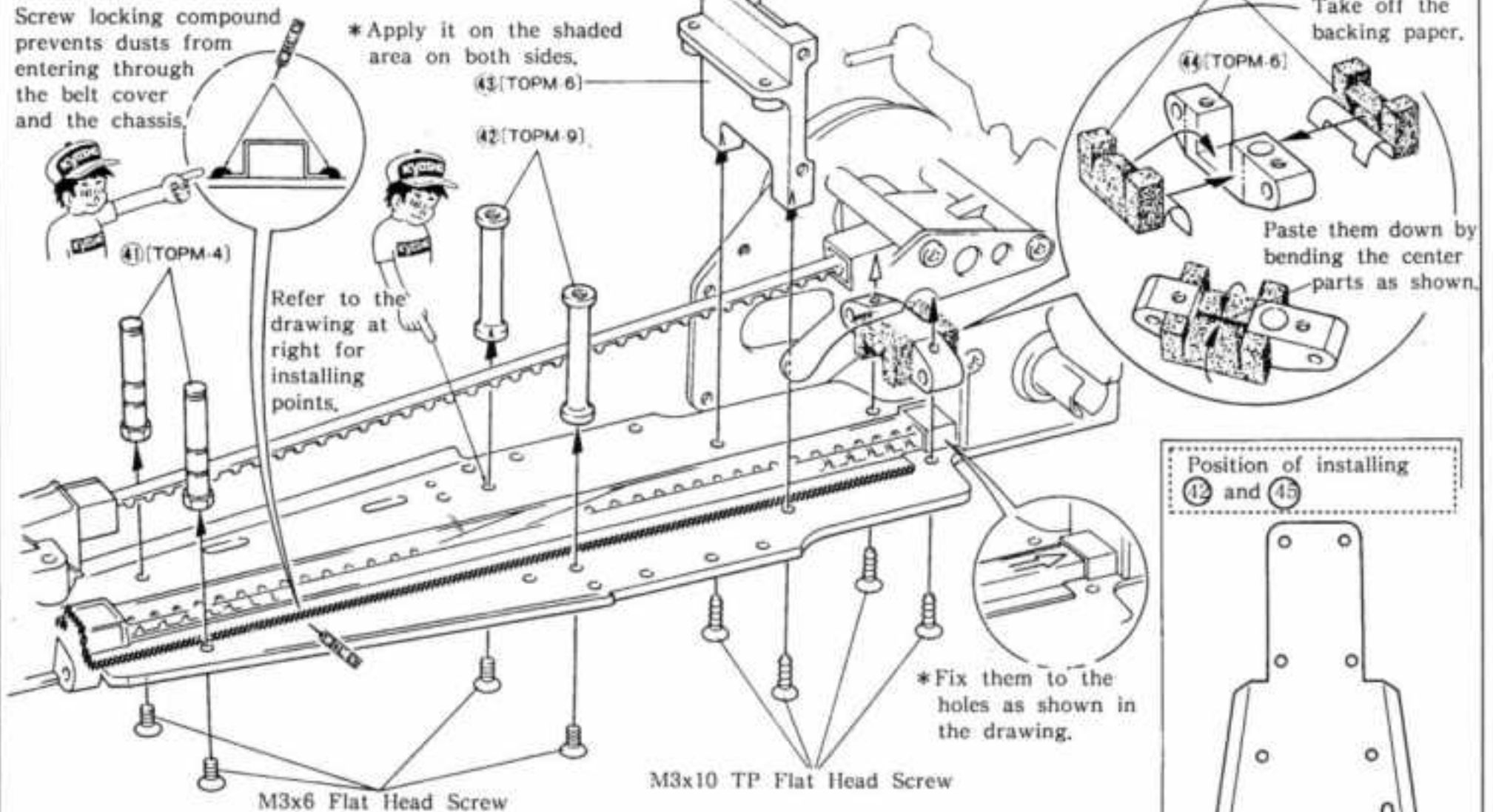

10 INSTALLATION OF BATTERY HOLDER

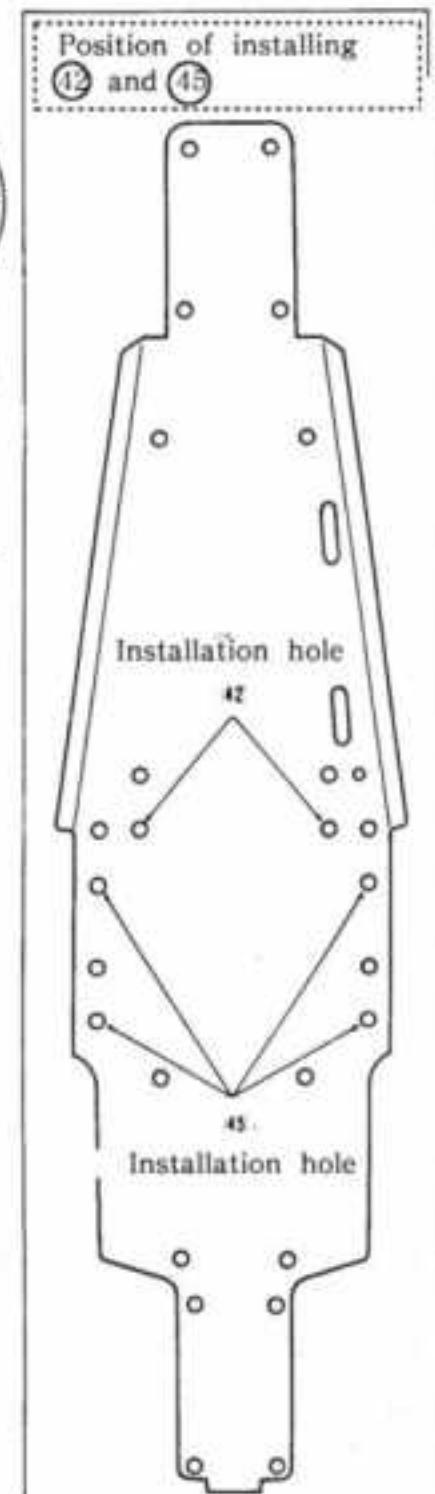
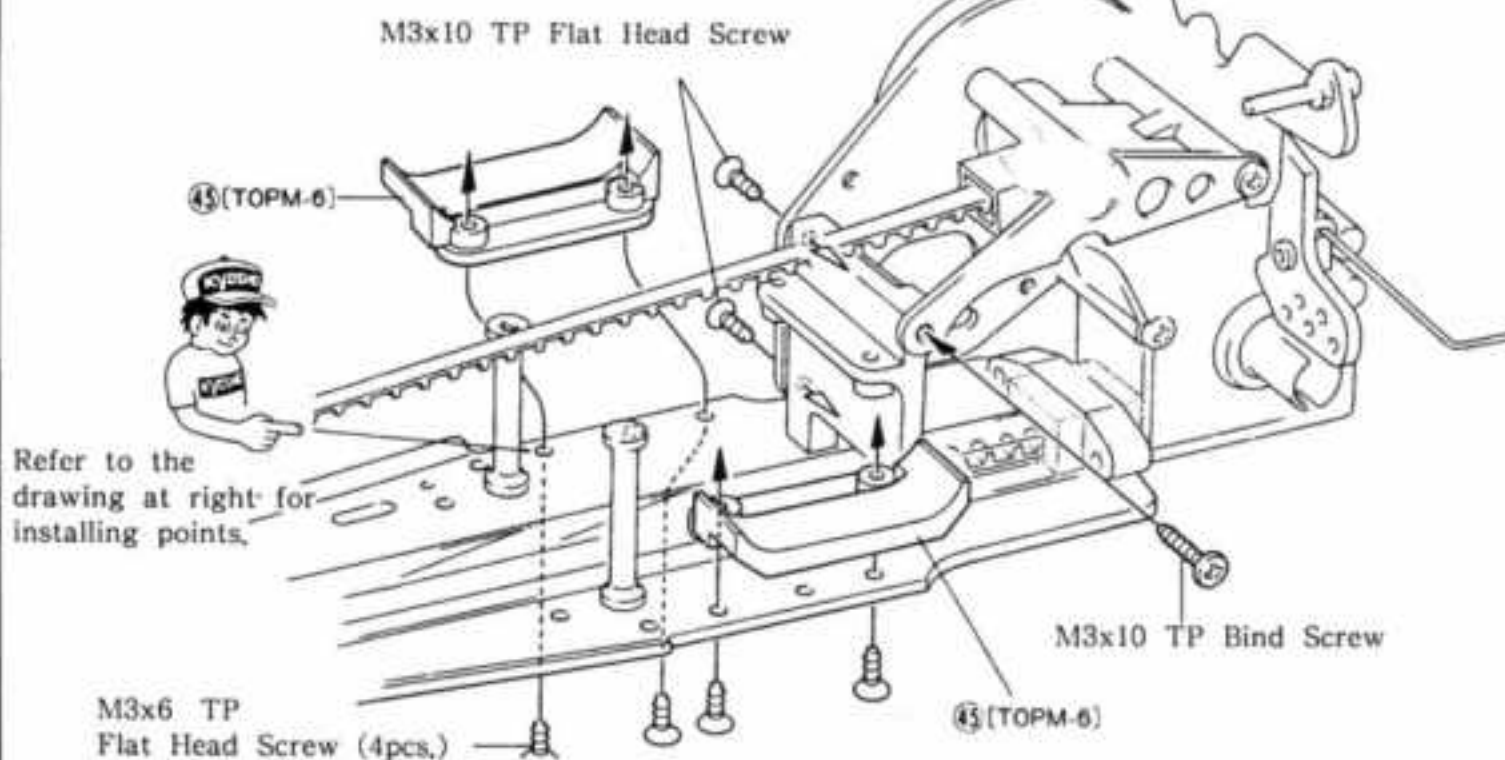

11 ASSEMBLY OF KNUCKLE ARM

Step 1 (Right Portion)

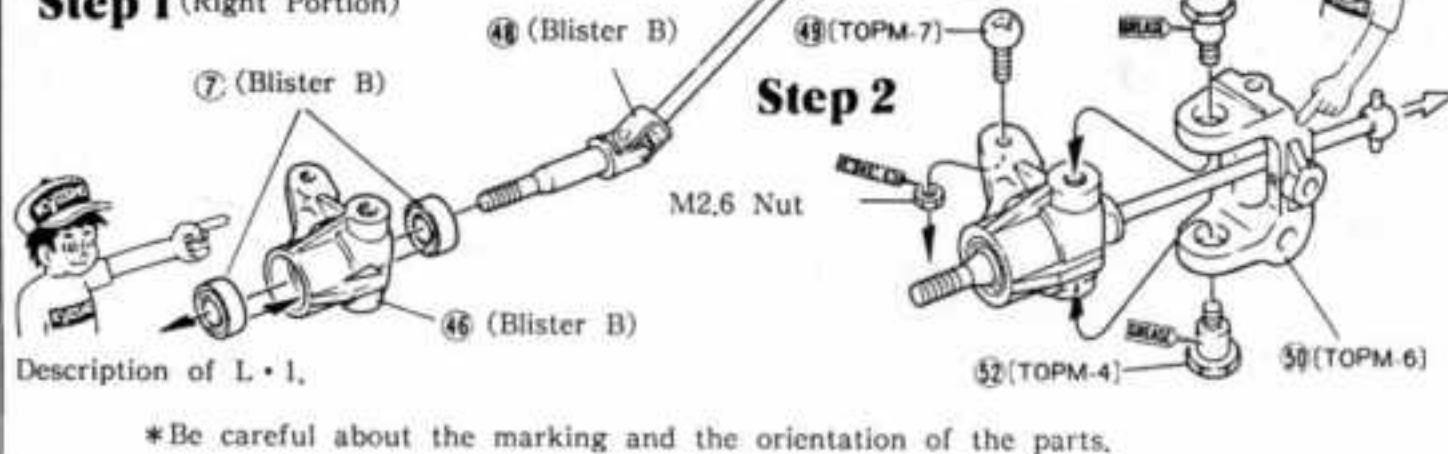

Molded marking of "R".

Step 3 (Left Portion)

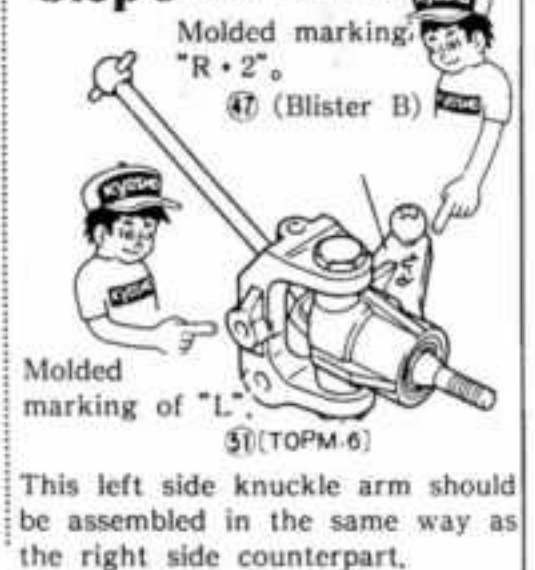

12 INSTALLATION OF FRONT SUSPENSION ARM

Fix the part 56 reversely on the left side.

Step 1

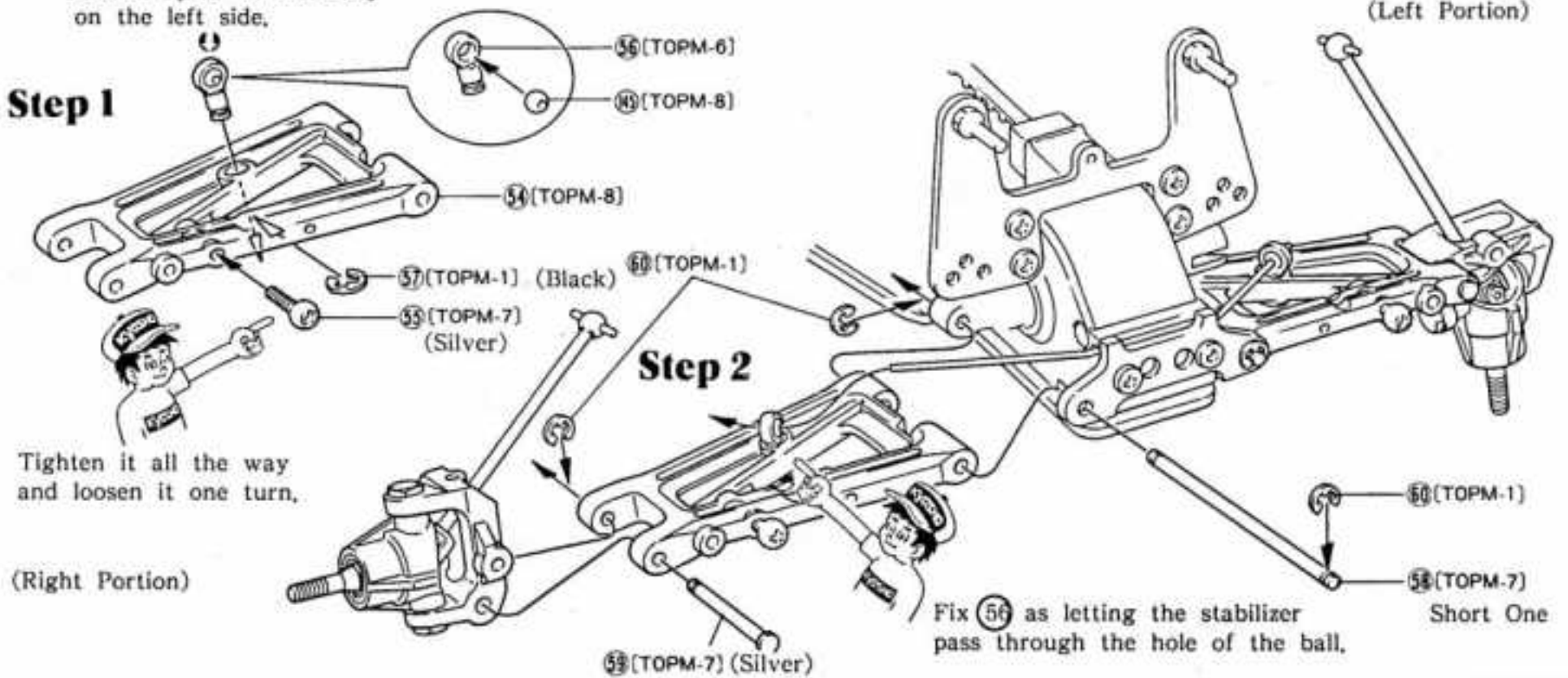

Tighten it all the way and loosen it one turn.

Step 2

Fix 56 as letting the stabilizer pass through the hole of the ball.

Short One

13 INSTALLATION OF FRONT UPPER ROD

Step 1

Assemble two pieces of the upper rod.

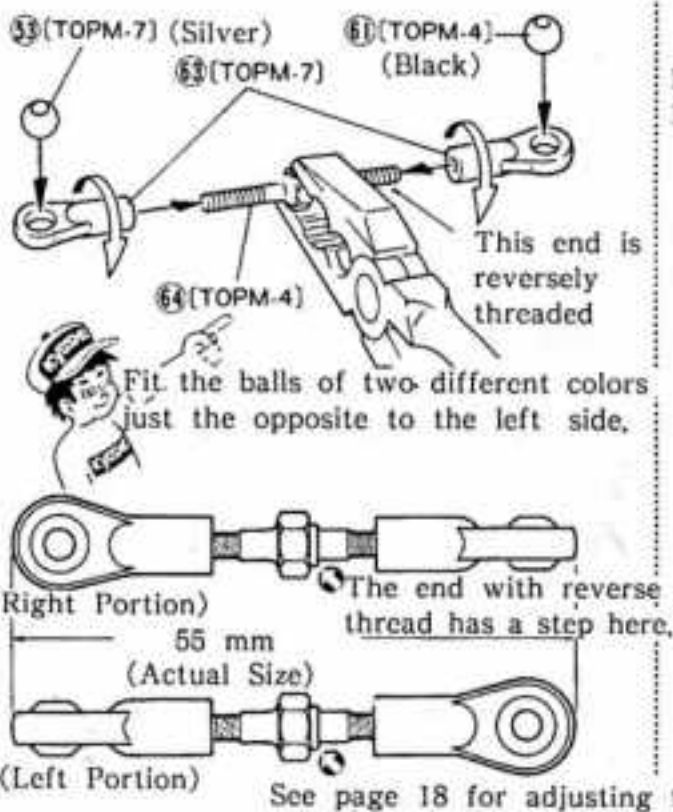

Step 2

The black ball end should be fastened to the shock stay.

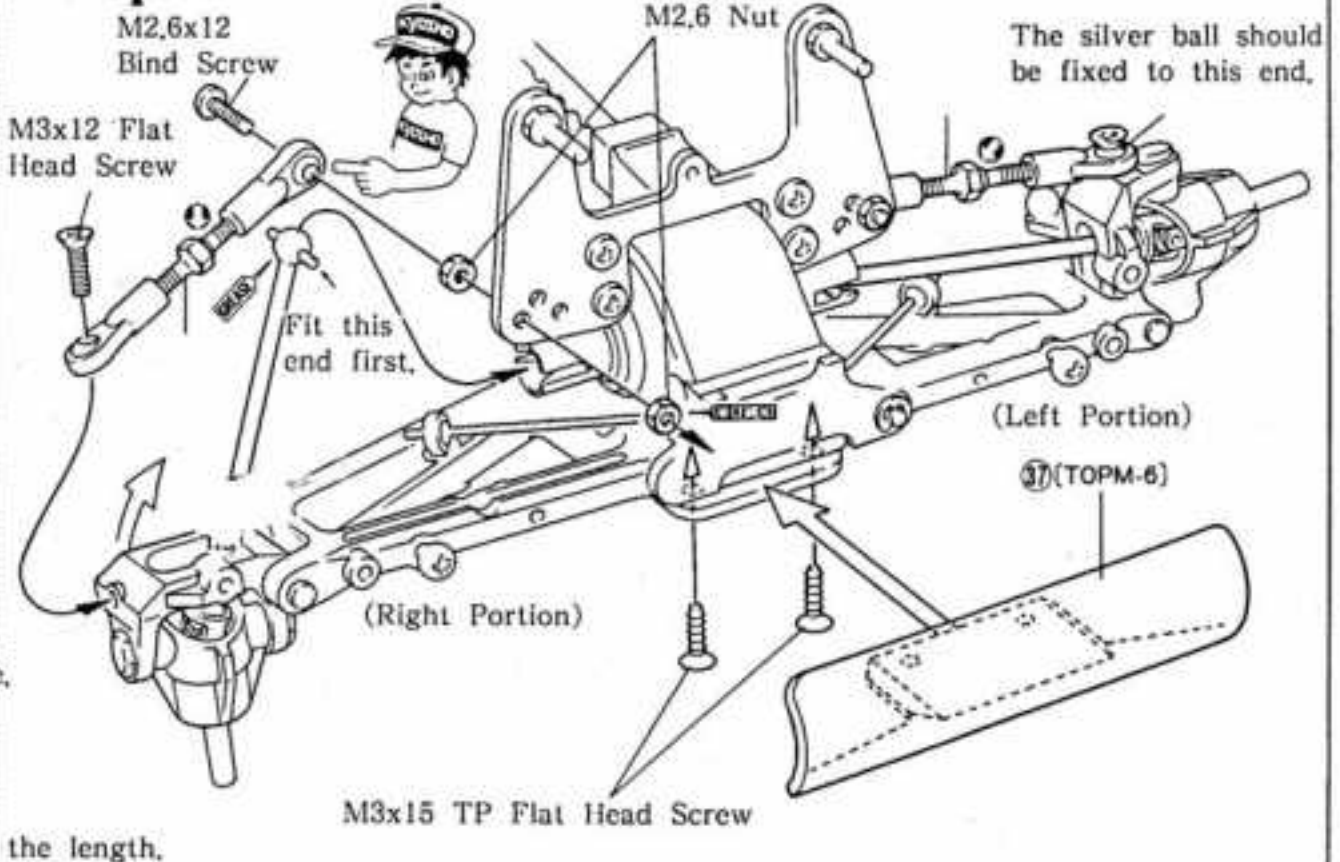

14 INSTALLATION OF REAR HUB

Step 1

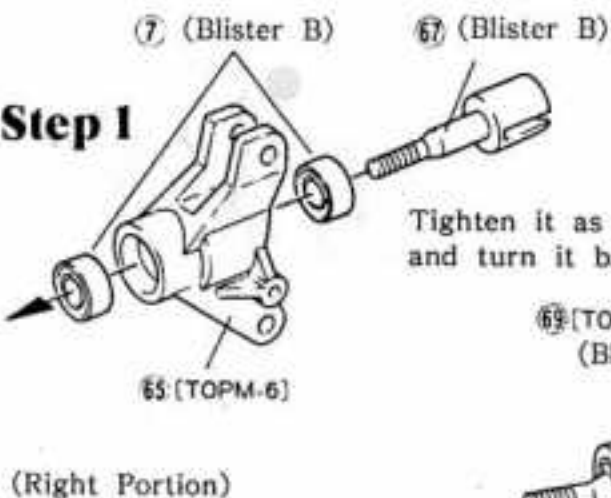

Step 2

Fix the screw into the most outer hole.

Tighten it as much as you can and turn it back for one turn

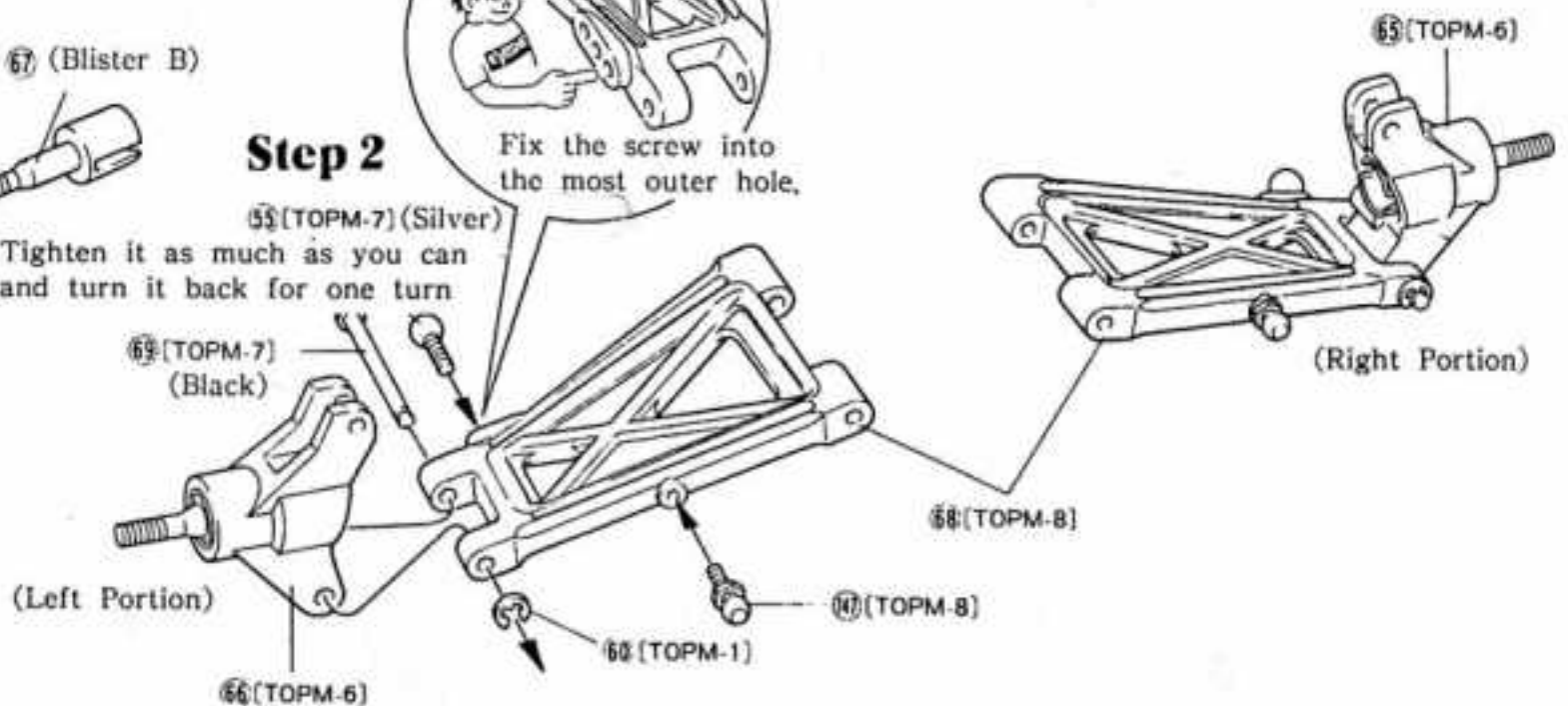

15 INSTALLATION OF REAR SUSPENSION ARM

<Installation of 149 stabilizer end ball>

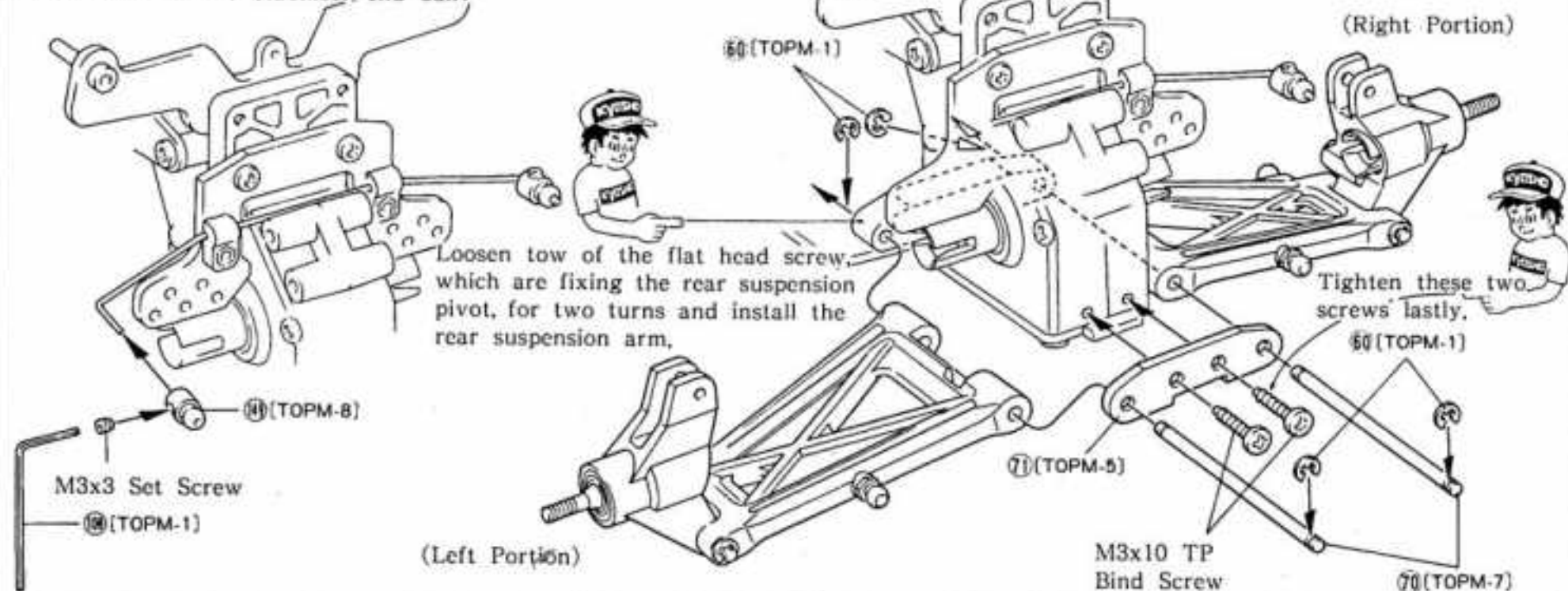

16 INSTALLATION OF REAR UPPER ROD

Step 1 (Assemble two pieces of upper rod.)

The illustration below is showing the left side upper rod.

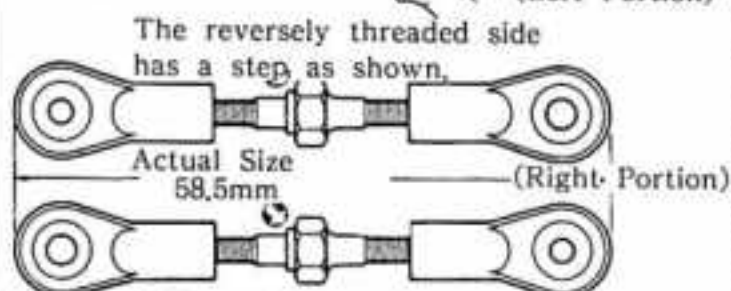
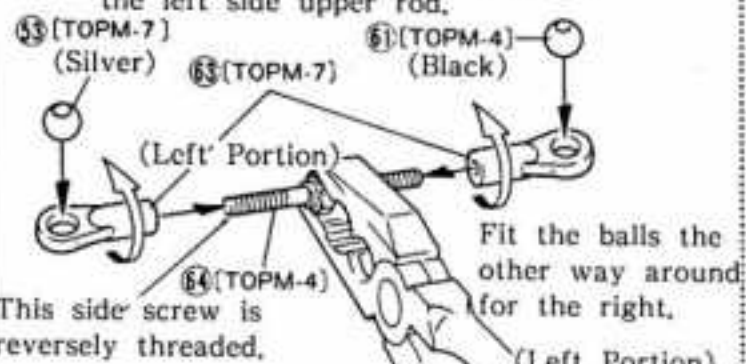

Step 2

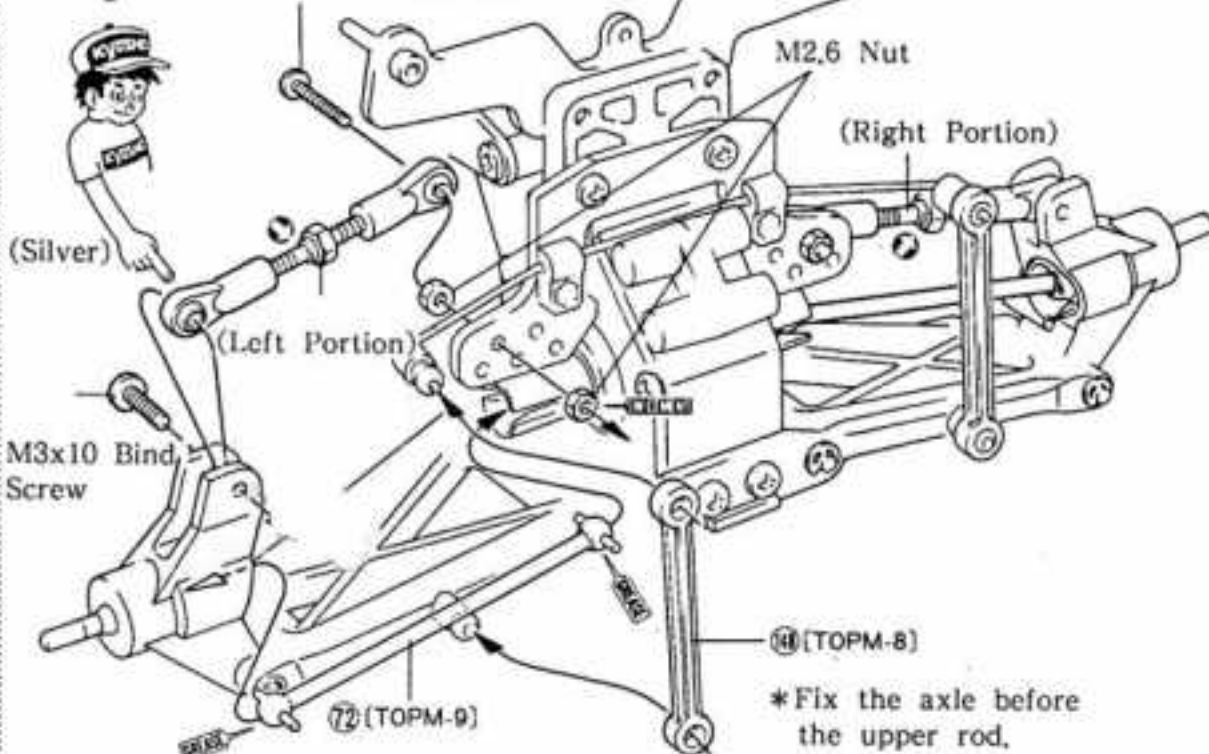

17 ASSEMBLY OF SERVO SAVER

Step 1 (Tighten the ball end.)

Cut off the shaded area so that the ball end should measure 19 mm long.

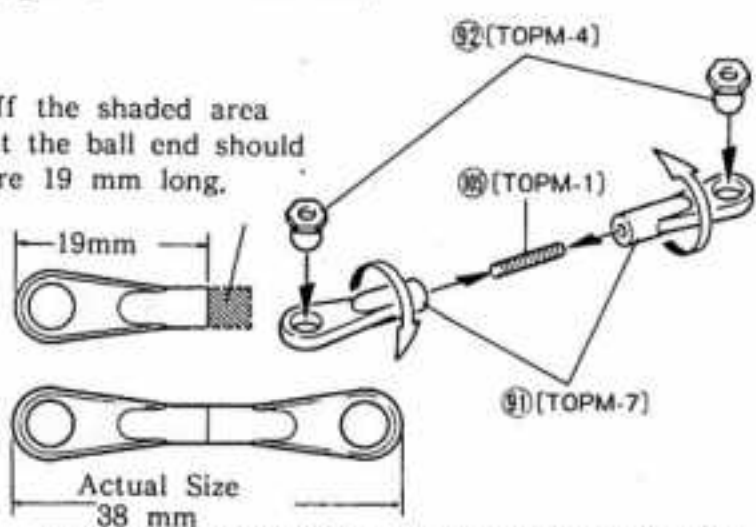

Step 2

Cut away the unnecessary part with a pair of clikes.

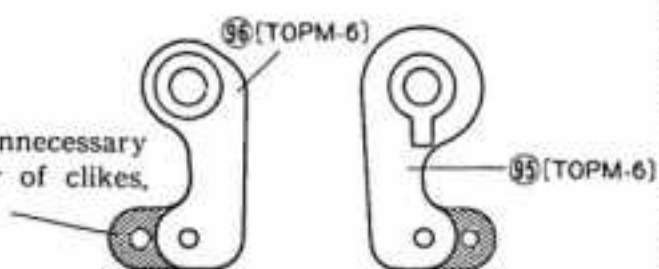

Step 3

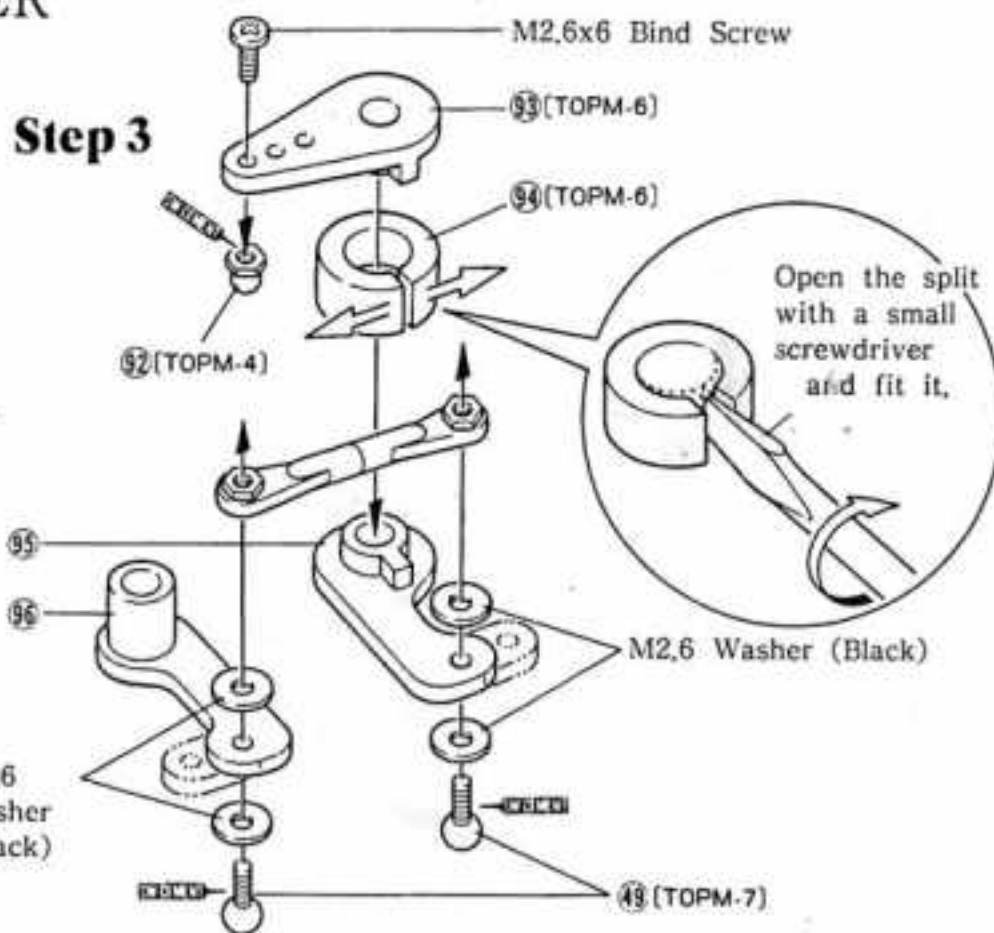

18 INSTALLATION OF SERVO SAVER (1)(TOPM-1)

Step 1

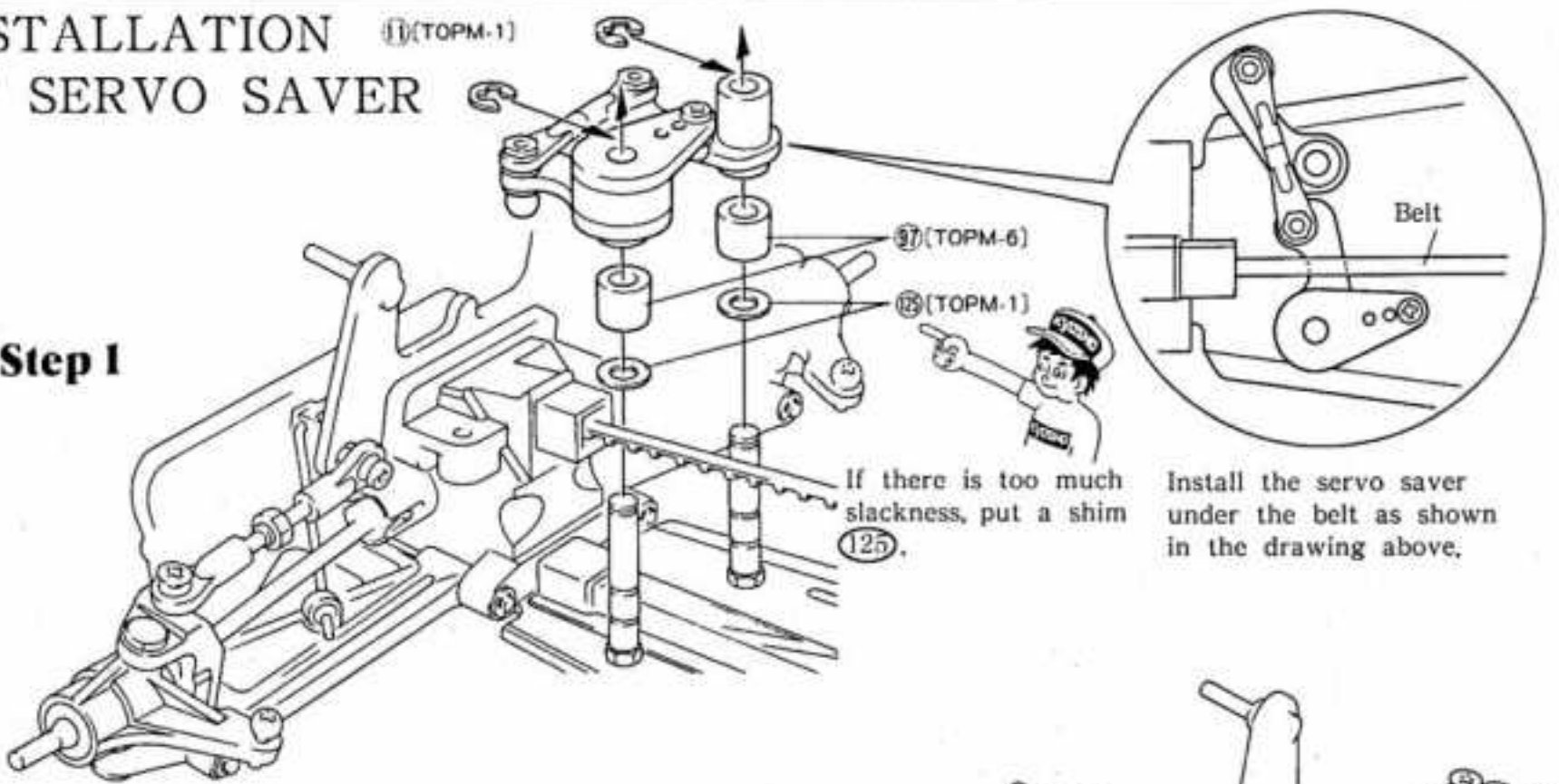

If there is too much slackness, put a shim (125).

Install the servo saver under the belt as shown in the drawing above.

Step 2

<Assembly of tie rod.>
Fix two pieces for the right and left.

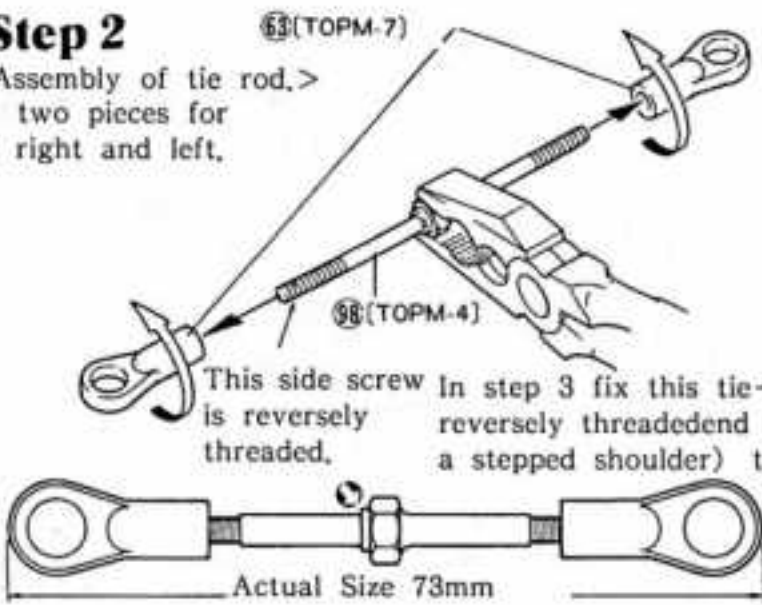

This side screw is reversely threaded. In step 3 fix this tie-rod with the reversely threaded end (marked with a stepped shoulder) to the left side.

Step 3

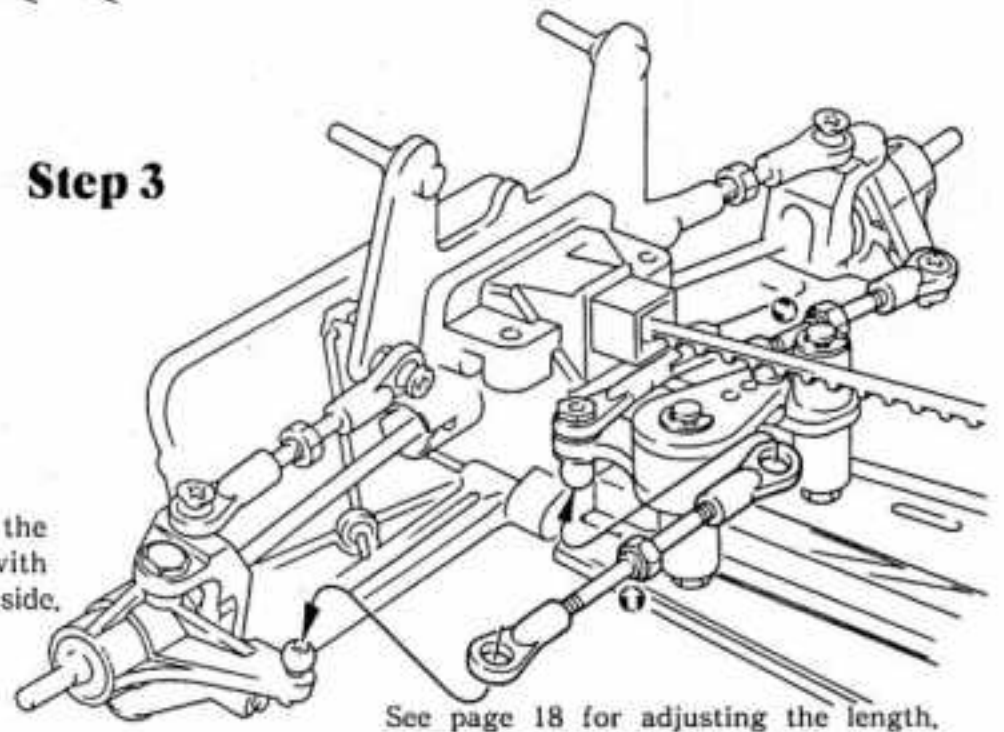

See page 18 for adjusting the length.

19 ASSEMBLY OF OIL SHOCK

Rear Shock Piston

Front Shock Piston

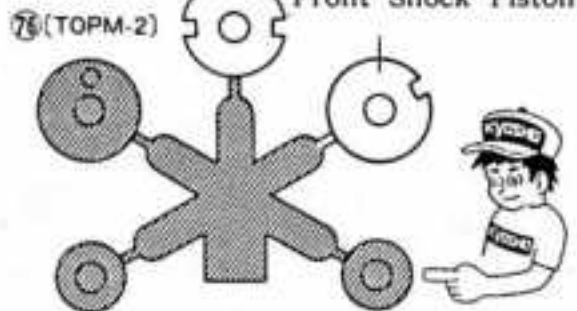

Cut away the shaded area, they will not be used.

Cut off the remaining of sprue runners carefully.



The parts marked with ★ will be used for the front and rear commonly.

Assemble the parts in order from 1 to 6.

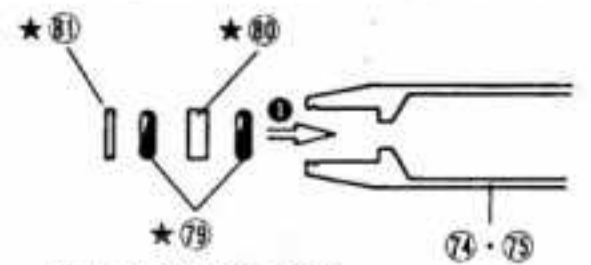

Put on an C-ring. (Be careful not to lose it.)

Fit into the groove.



Fix the piston with an E-ring.

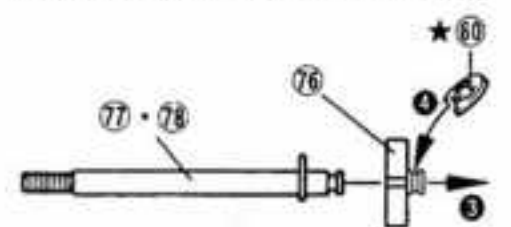

Put the shaft through the shock case and screw in the shock end.



Screw it in.

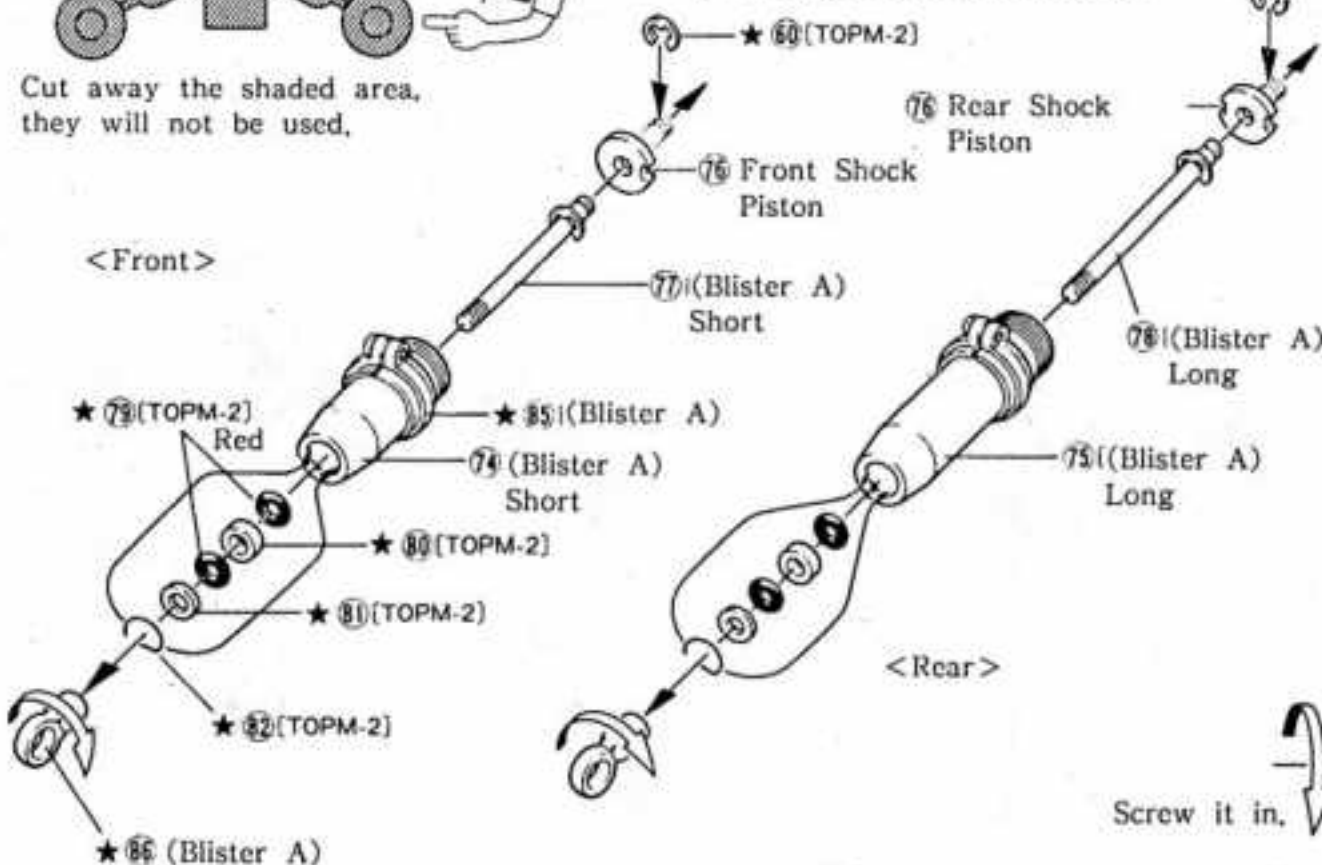

20 FILLING THE SHOCK OIL

Step 1 Pull down the piston to the bottom and pour oil slowly. Then move the piston up and down gently to get rid of air bubbles.

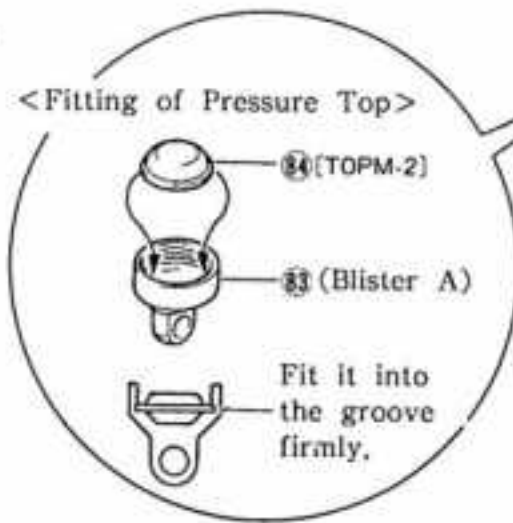
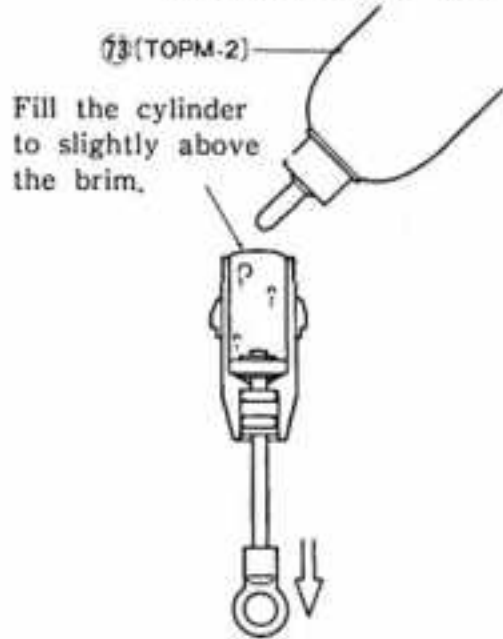

Step 2

Keep the piston in the lowest position and tight (83) gradually, then excessive oil will run over.

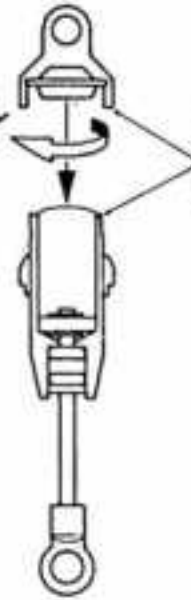

Step 3

Confirm that it will work smoothly by moving the piston up and down.



21 INSTALLATION OF SHOCK SPRING

Step 1

Put the spring over it.

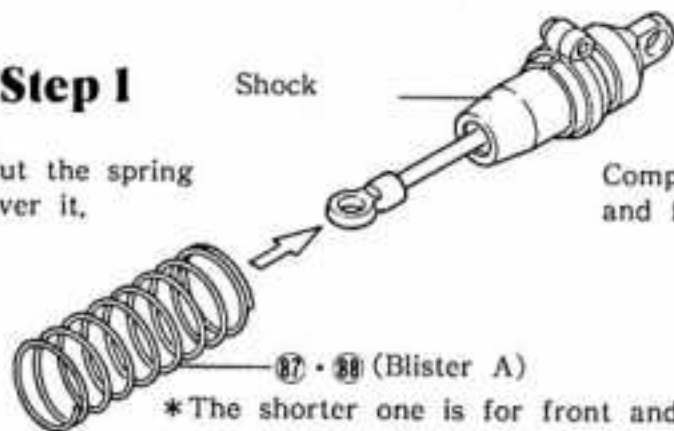

Step 2

Compress the spring and fix the (89).

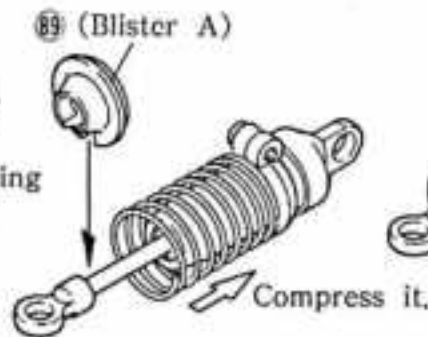

● Front Shock Short

● Rear Shock Long

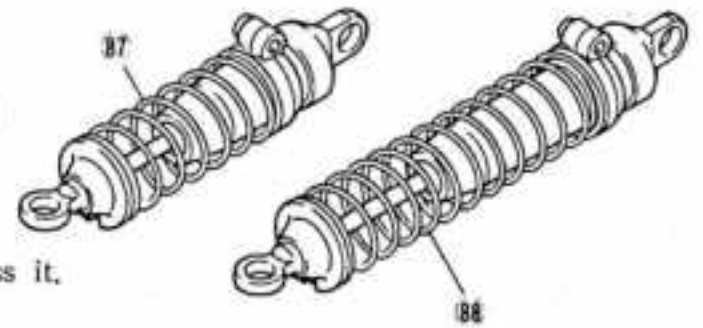

22 INSTALLATION OF SHOCK

<Front>

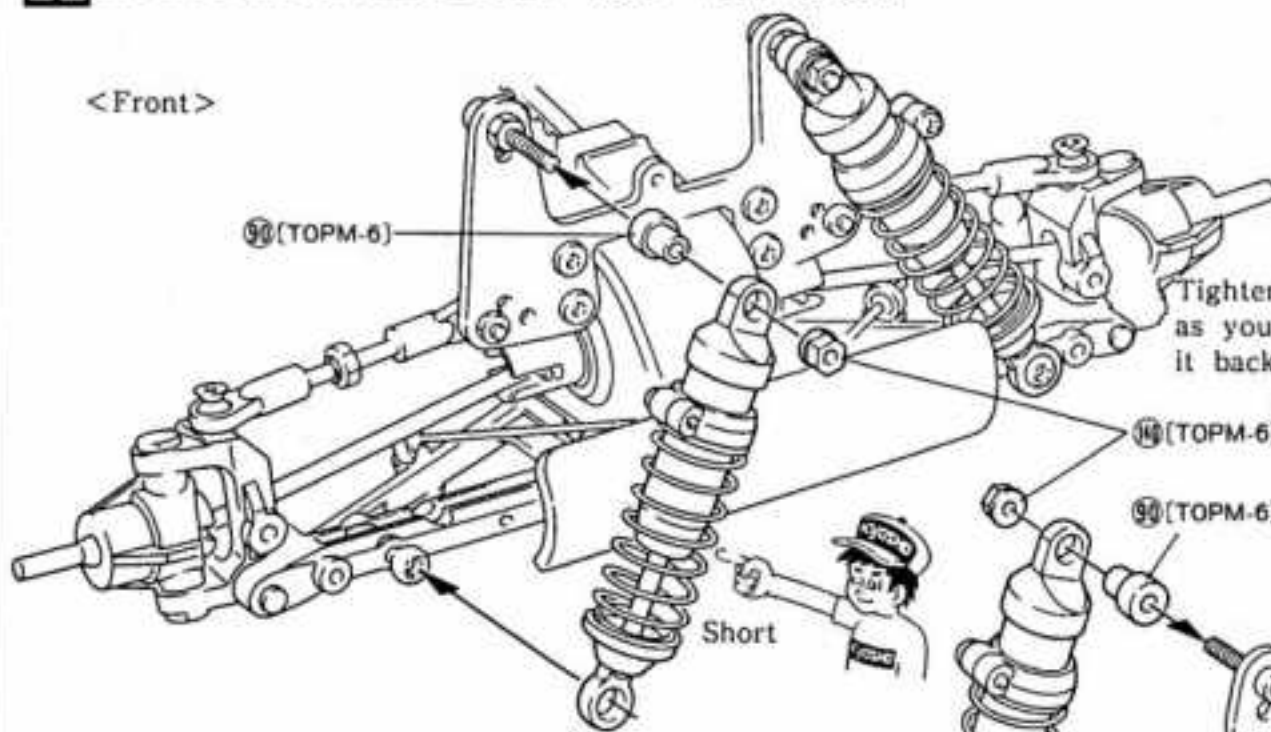

Tighten it as much as you can and turn it back for one turn.

Tighten this screw temporarily, since the upper part of the shock will be unfastened for a short time in the step 30 "Mounting of Motor".



Long

<Rear>

23 INSTALLATION OF MOTOR CORD

Step 1

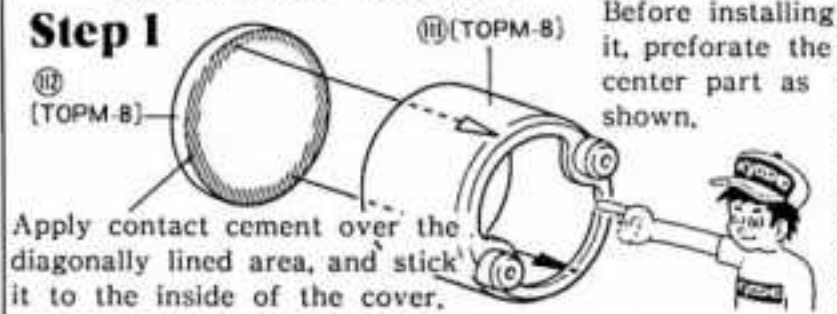

- SPA 240WS
- Le Mans Sport H-240S

Step 2

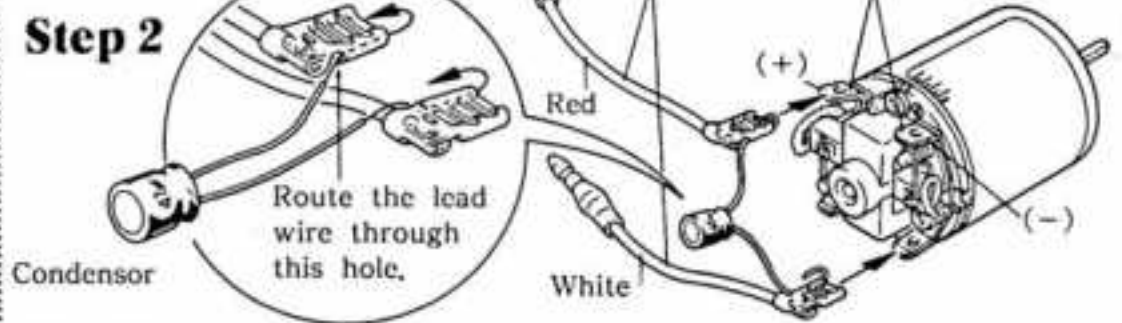

Step 3

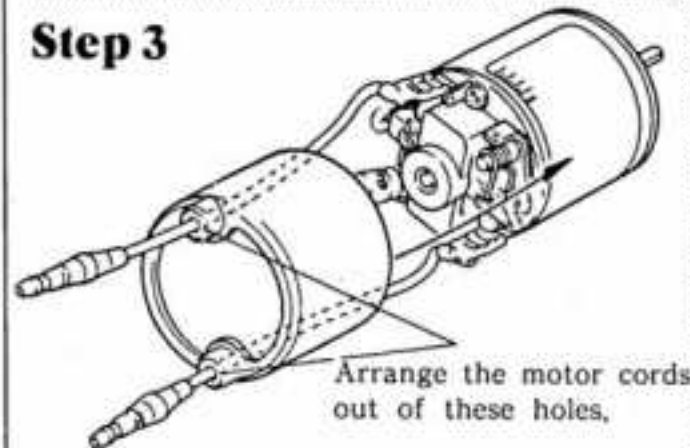

Motor is not included in the kit. The suitable motors are SPA240WS, Le Mans Sport H-240S and Le Mans 240SB.

- Le Mans 240SB

Cut the motor cord as shown below and solder it to the motor.

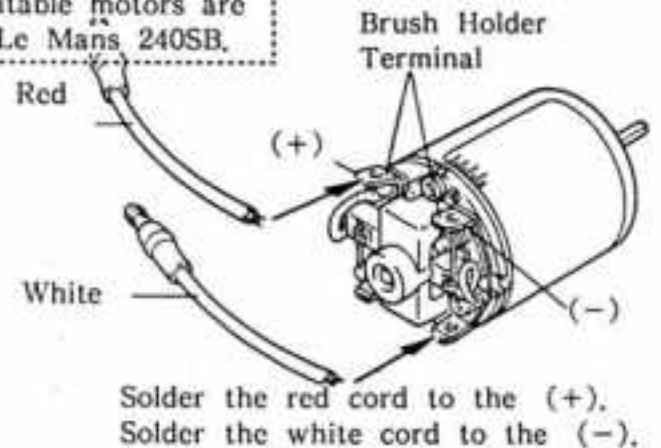
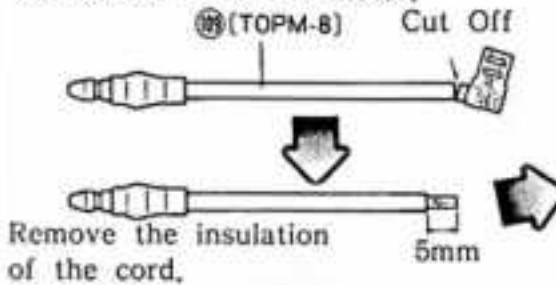

24 HOW TO CHECK RADIO SYSTEM

*Operate the radio units in numerical order.

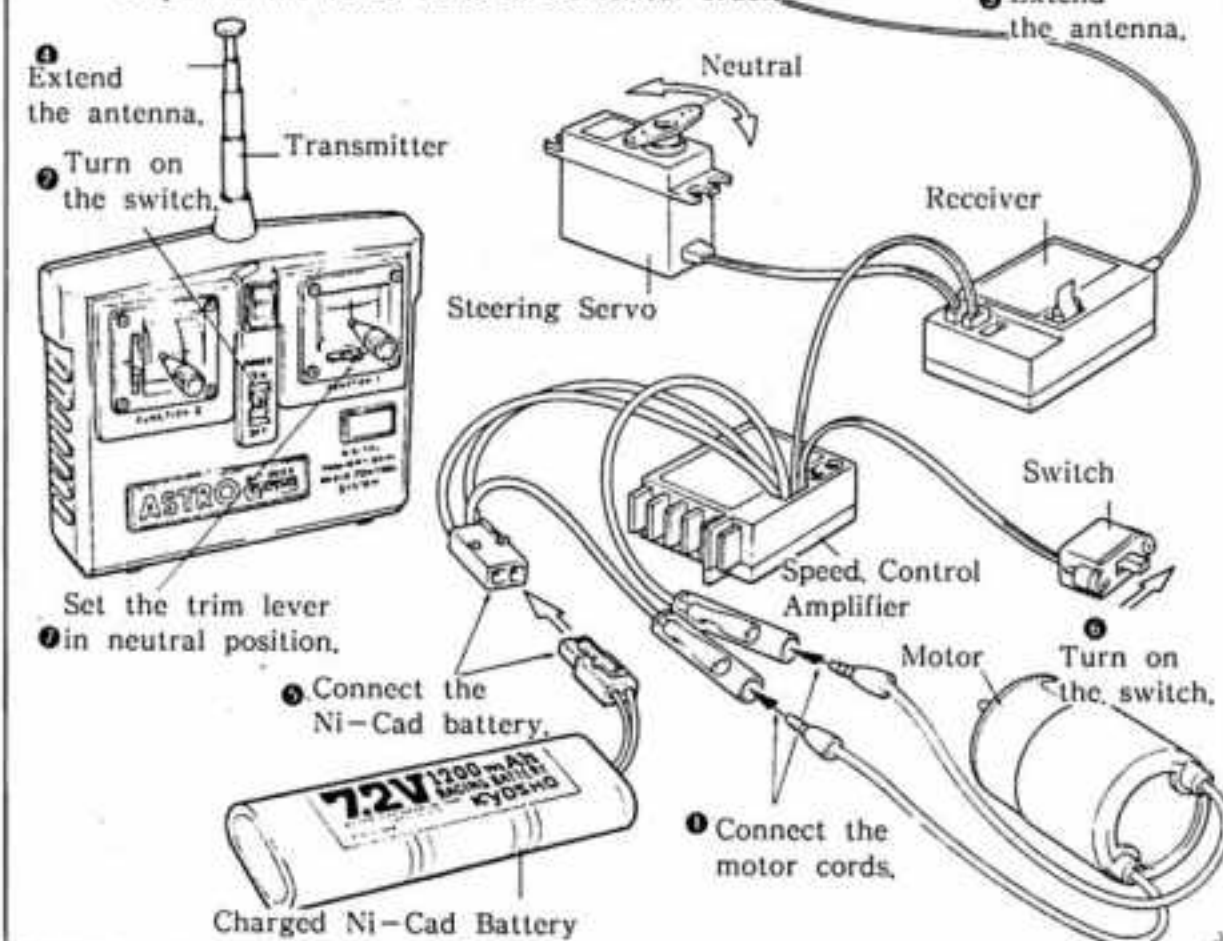

(Transmitter)
It is in effect a control box. Signal waves are transmitted through an antenna according to the stick movements.

(Receiver)
Receives the signals from the transmitter and send them to the servos.

(Servo)
They really move the control mechanism of a model car in accordance with the signals from the receiver.

(Antenna)
An antenna on the transmitter sends signals, and one on the receiver accepts them. They should be fully extended.

(Trim Lever)
They will adjust the neutral position of servos, thus regulate the steering and advancing controls finely.

(Battery Meter)
You can tell the amount of electricity in a battery and how the signals are emitted.

(Servo Horns)
They are intermediate devices on the servos to activate the controls. There are several types in shape. They should be selected depending upon the usage.

It is important to always switch the transmitter on first...then the receiver. When turning off the system, turn off the receiver first and then transmitter.

25 INSTALLATION OF STEERING TIE ROD

Step 1 <Cut Off Shaded Part>

Enlarge the hole with an awl so that you can put the control easily.

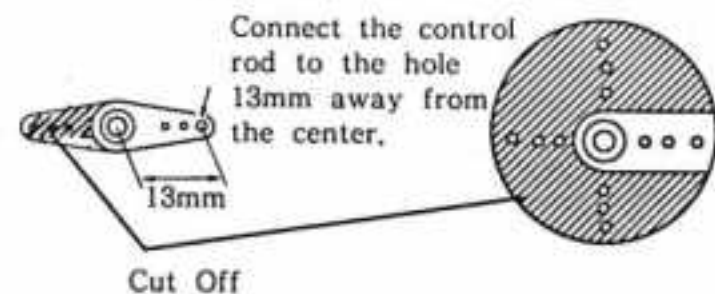

Step 2

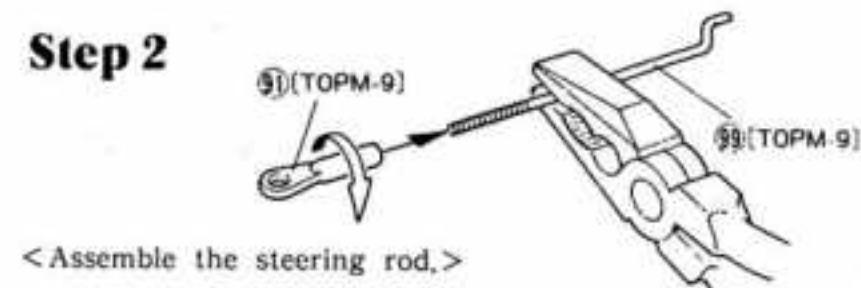

Step 3

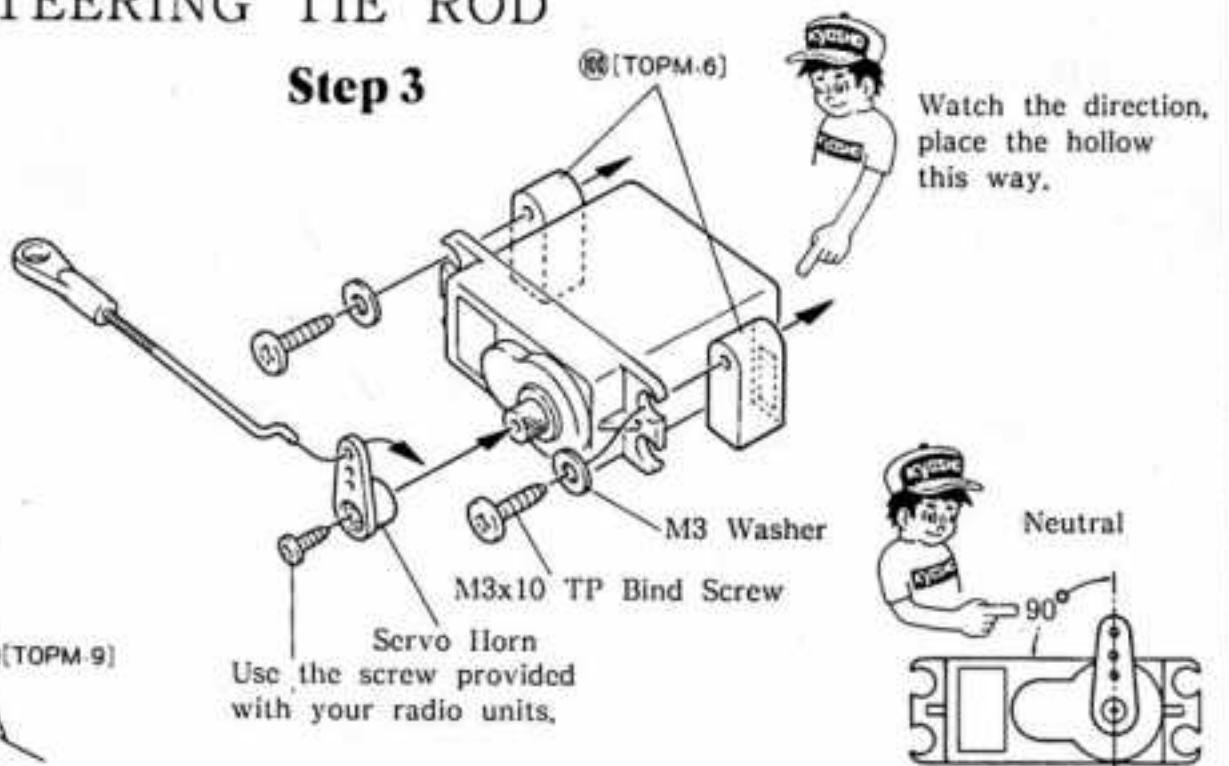

26 INSTALLATION OF STEERING TIE ROD

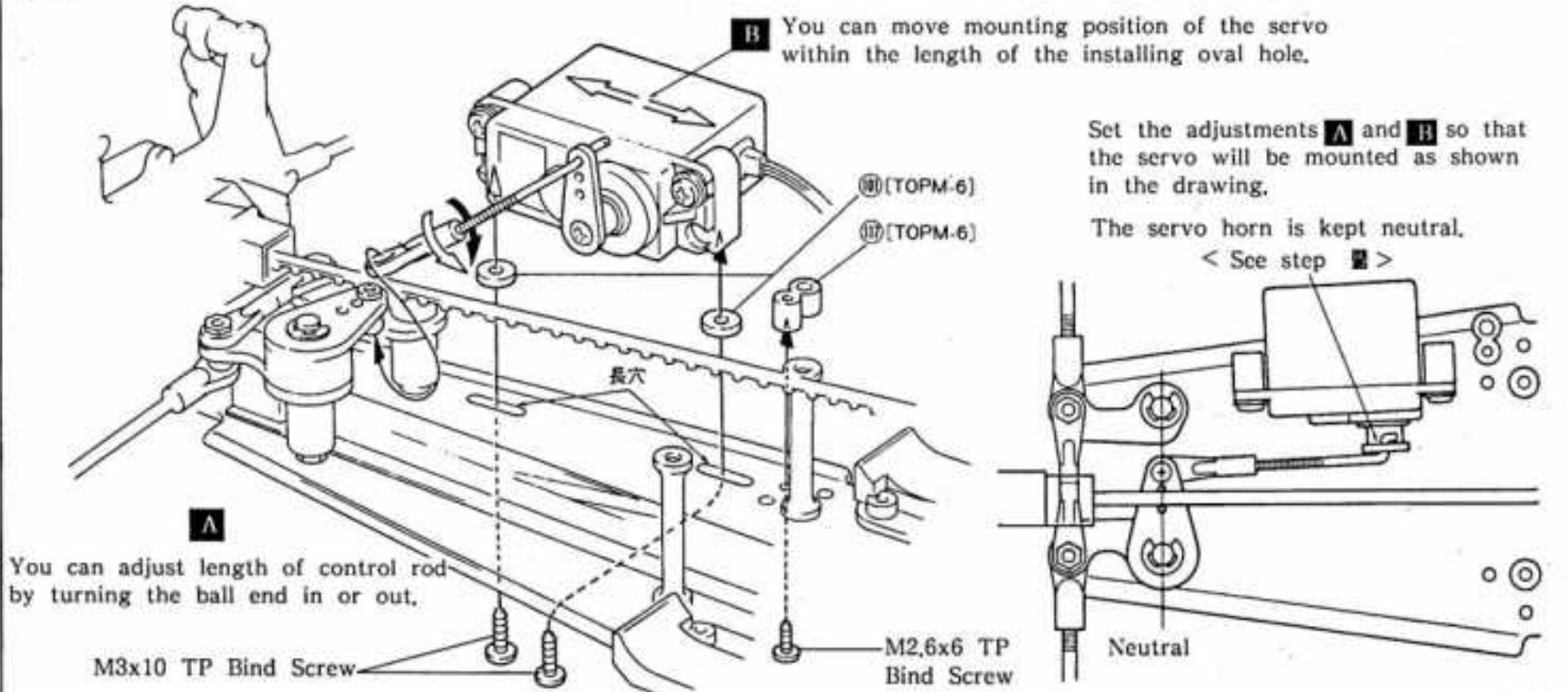

27 INSTALLATION OF UPPER DECK

Step 1

(In the case of an amp with a switch, fix the switch in this step.)

Use the screws provided with your radio units,

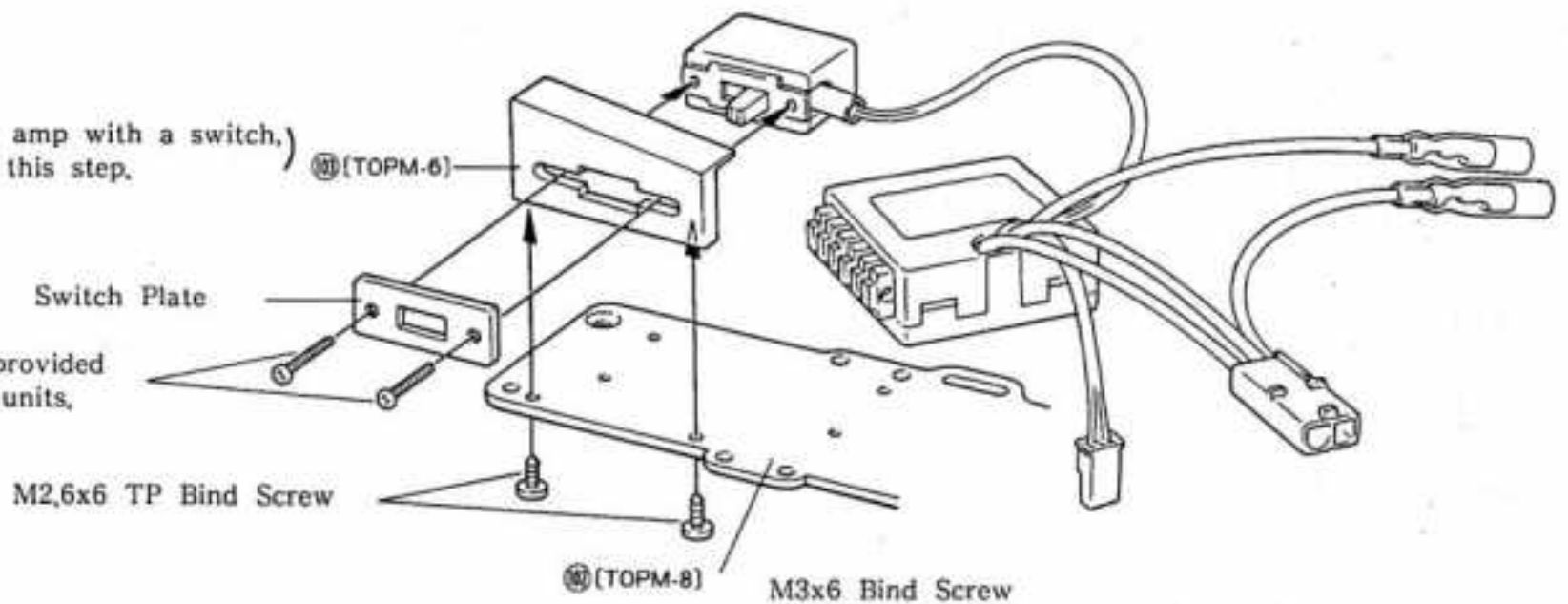

Install the upper deck through the belt loop.

4x12 Bind Screw

Step 2

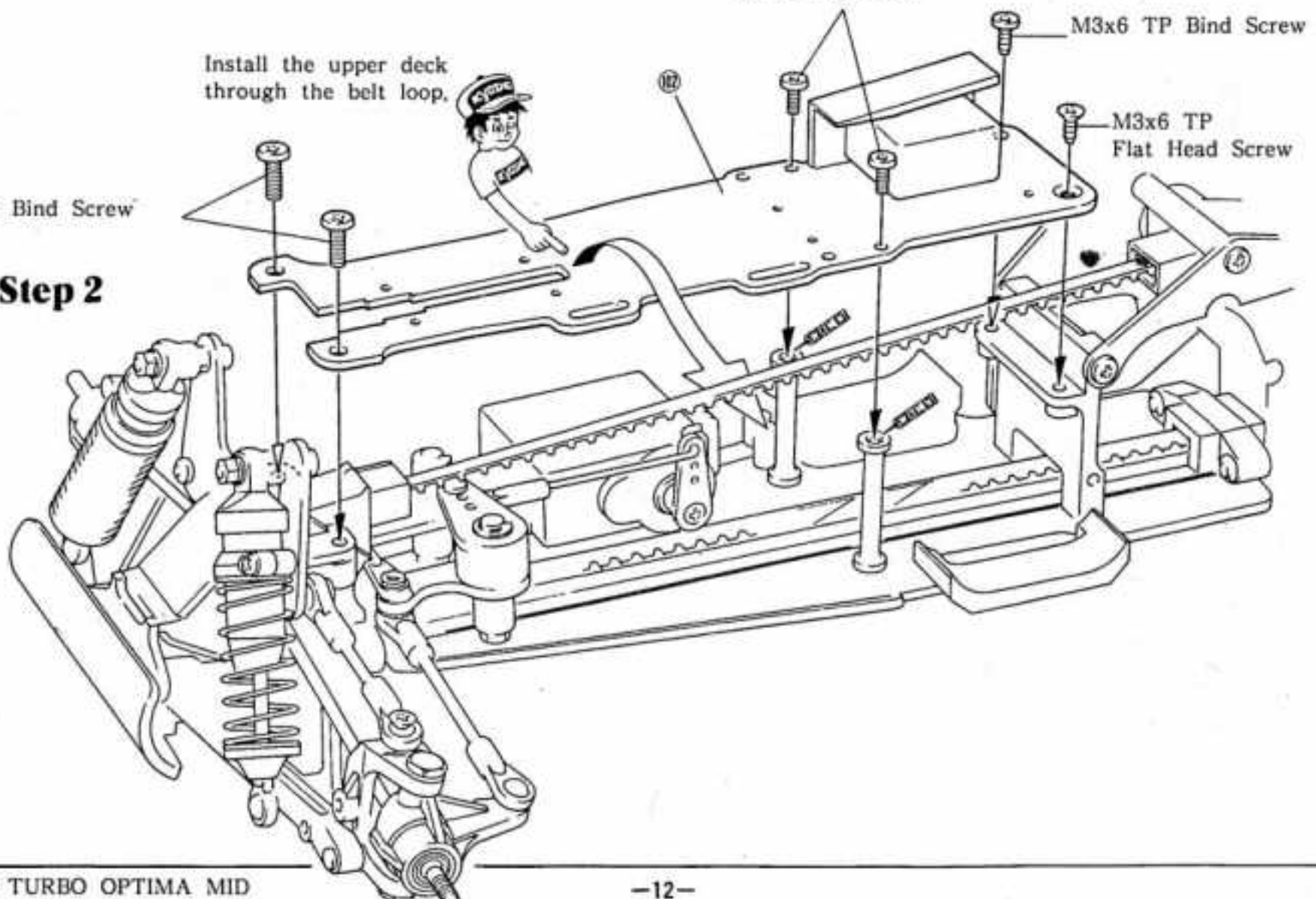

28 INSTALLATION OF BELT COVER (B),(C)

Step 1



Cut off the shaded area along with the cutout line.

Step 3

After installing the belt cover, apply screw locking compound along the obliquely lined edges, (both sides) as done in step ⑨.

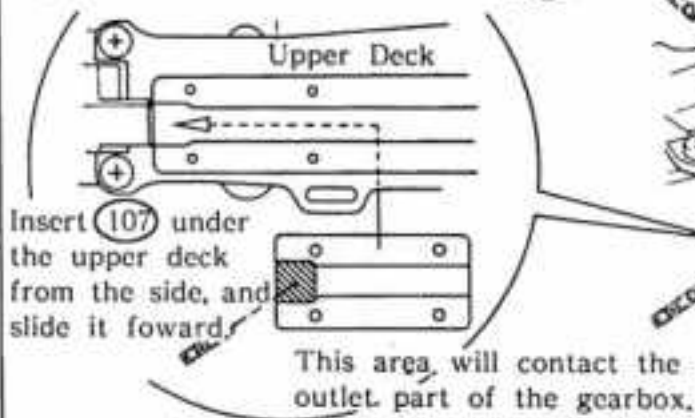

Step 2

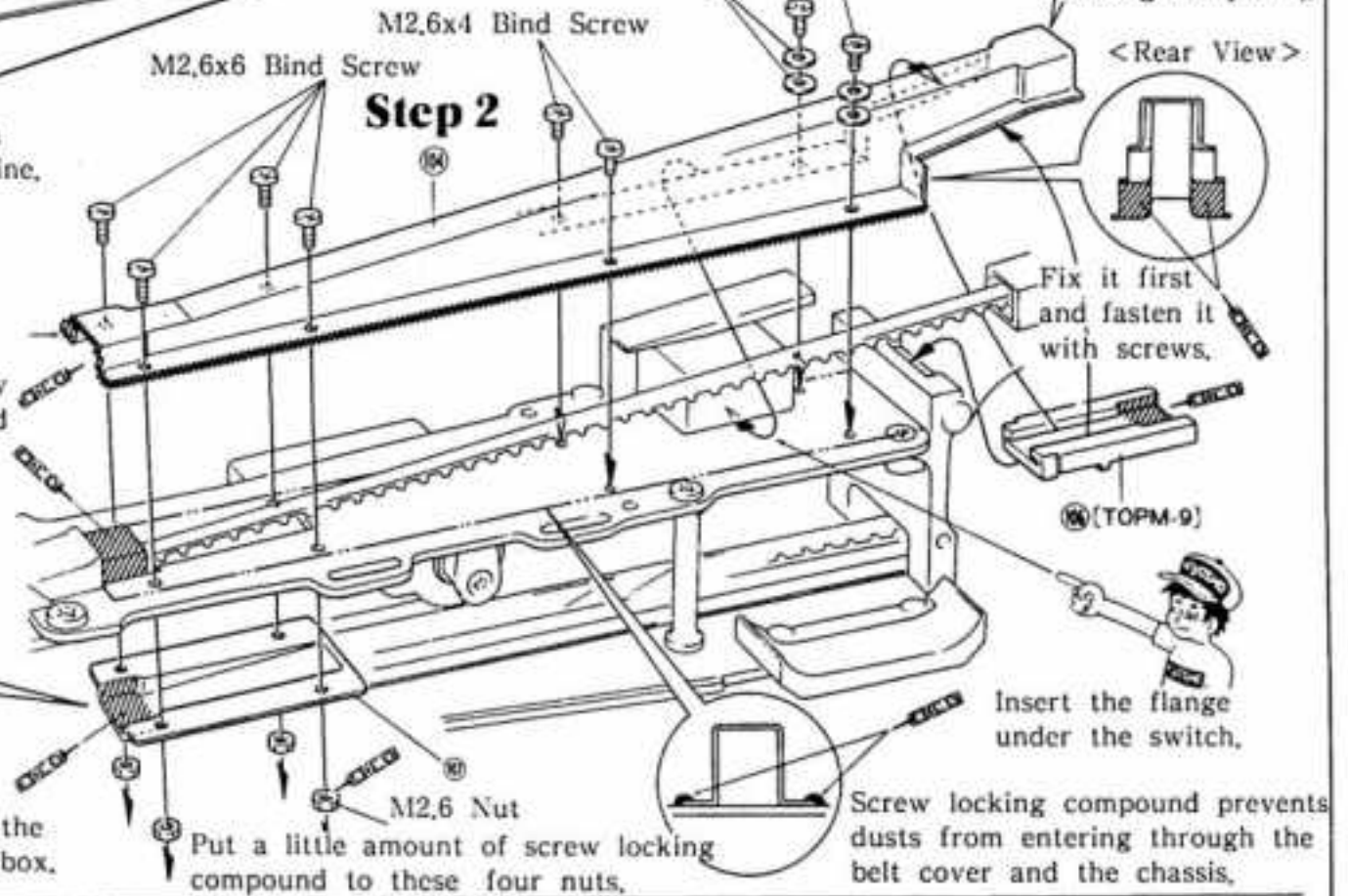

29 CHECK OF BELT COVER

Through even a small opening on the fitting edge of the belt cover, dust may get in. The dirt or dust inside may chip the gear teeth or damage the belt resulting in loss of power or noise. Check again to see if the seams are all sealed completely with screw locking compound.

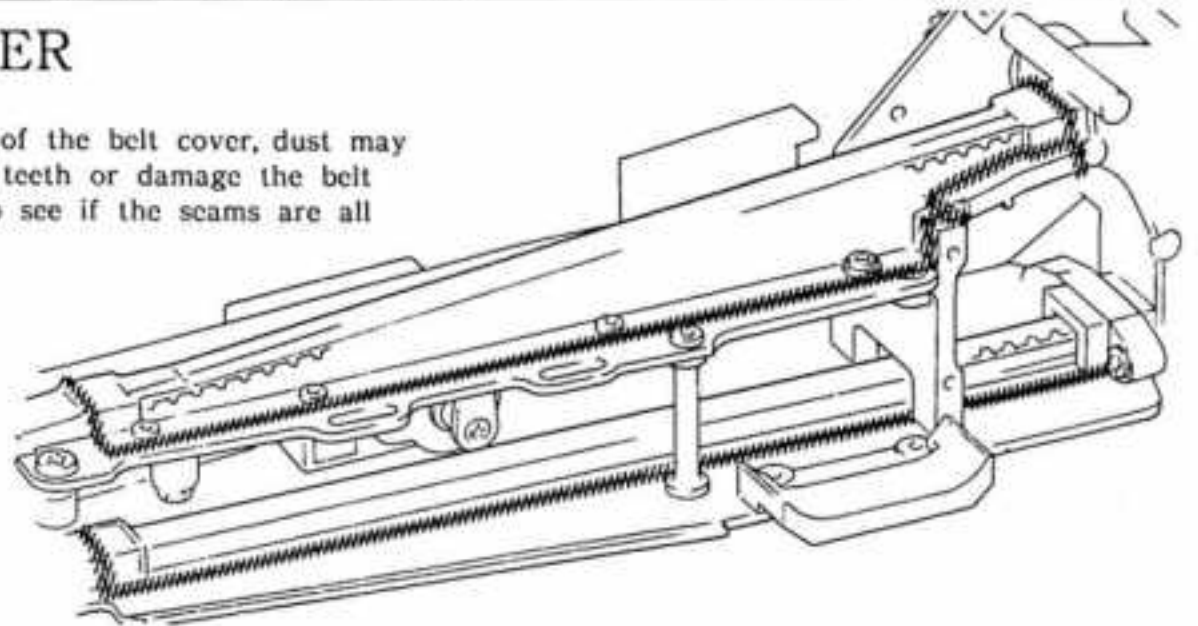

30 INSTALLATION OF MOTOR

Step 1

Take off the upper end of the right shock temporarily.

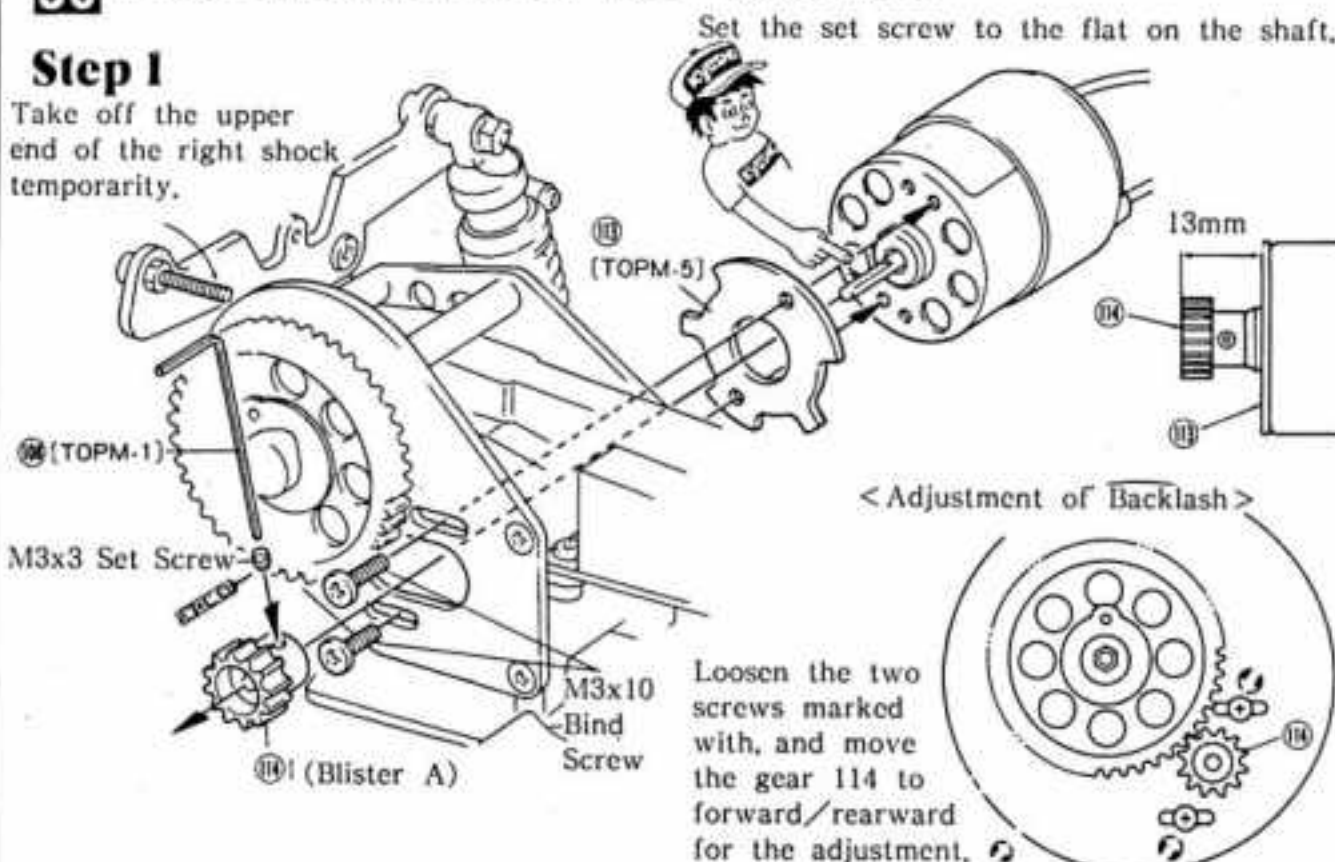

Step 2

After installing (115), fix the shock as it was before. Cut off the striped area before fixing it.

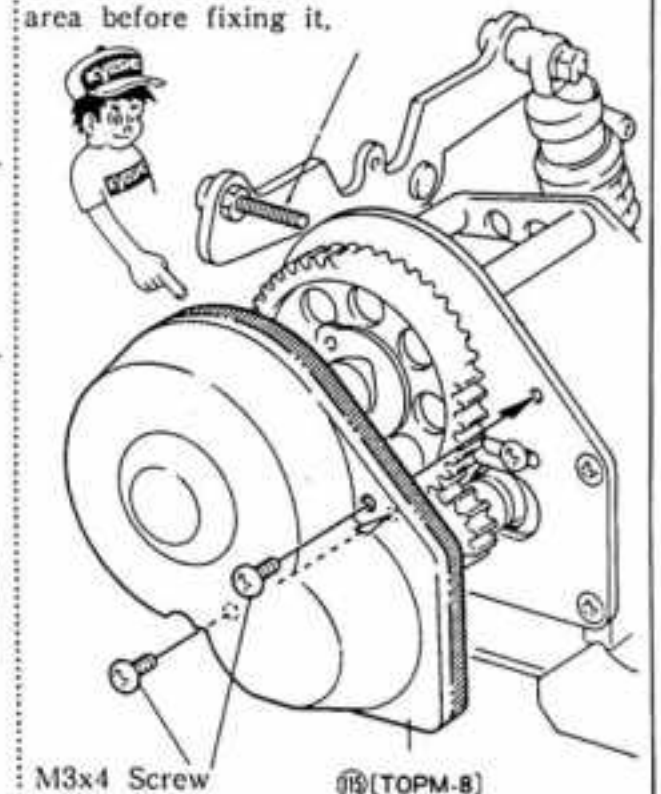

31 INSTALLATION OF AMP.

<With A Small Amp.>

Arrange the amp so as not to rub against the servo horn.

Cut the tape to the length of the amp.

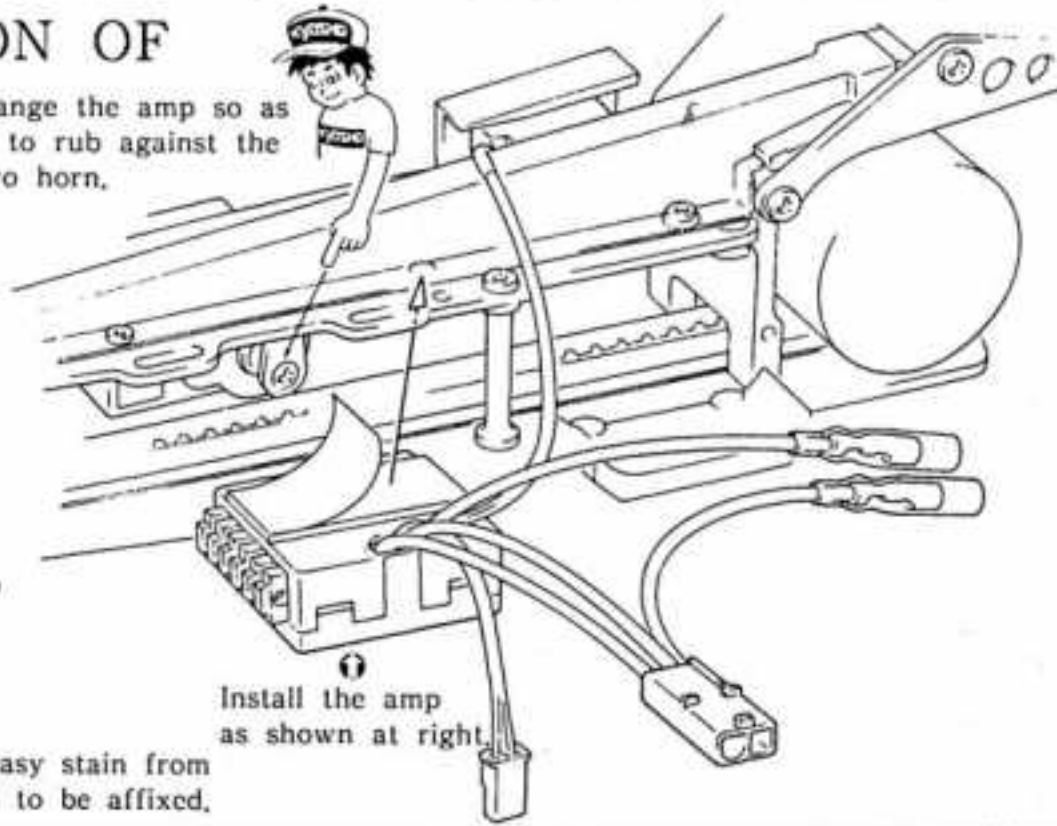
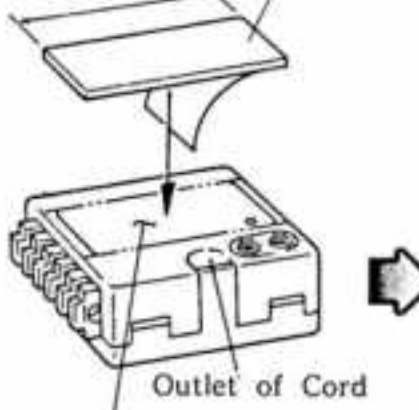

Install the amp as shown at right.

<Assembled View>

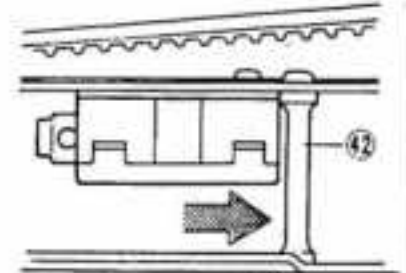

Put the rear of the amp close to (12).

Wipe off oil of the fingers or greasy stain from the surface where the tape (116) is to be affixed.

<With A Servo-Type Amp.>

If the amp is too big to install as shown below, mount it with dual adhesive sponge tape onto the place, where the receiver is to be fixed in step 32; and install the receiver under the plate as shown above.

(116) [TOPM-6]

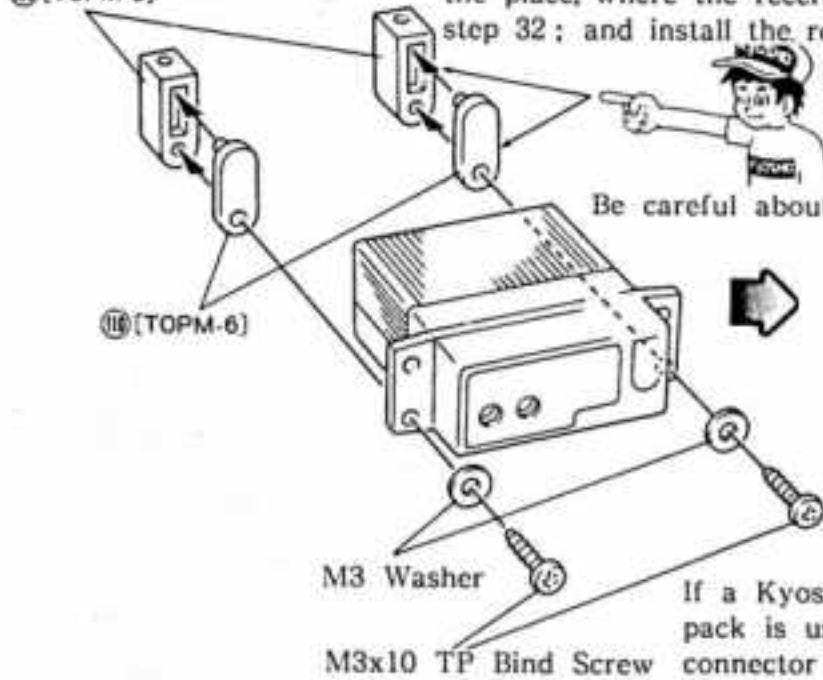

Be careful about the orientation.

M3x10 TP Bind Screw

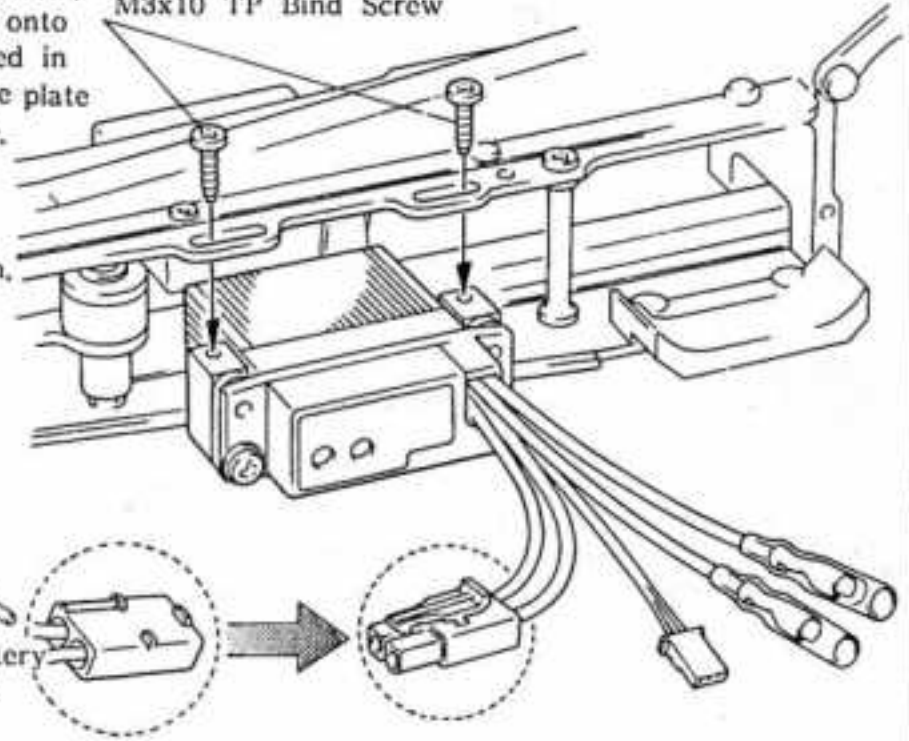

<With An Oblong Amp.>

Wipe off oil of the fingers or greasy stain from the surface where the tape (116) is to be affixed.

Cut the tape (116) to the length of the amp or the switch.

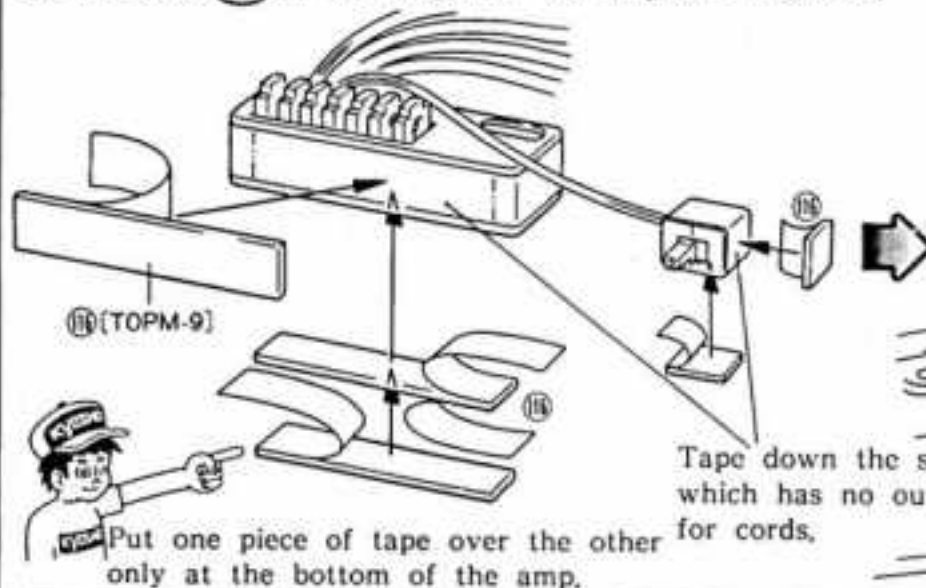

Tape down the side which has no outlet for cords.

Fasten it tight and cut off the excess.

<After the amp is fixed>

Plug in the motor connector.

Red (+)

Red (+)

If the cords are too long, bind them with a strap (119) for convenience' sake.

Black (-)

Be careful about polarity.

White (-)

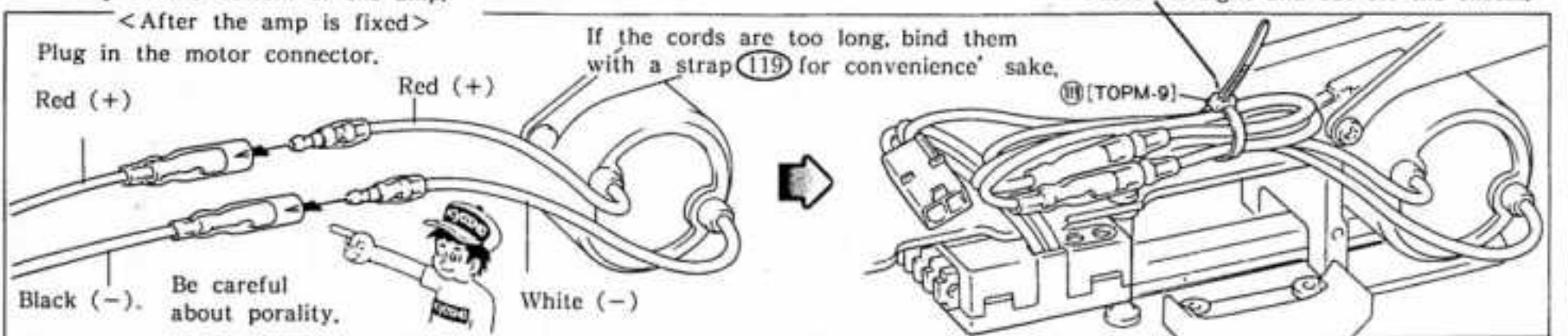

32 INSTALLATION OF RECEIVER Step 1 <Cutting of Double Sided Tape>

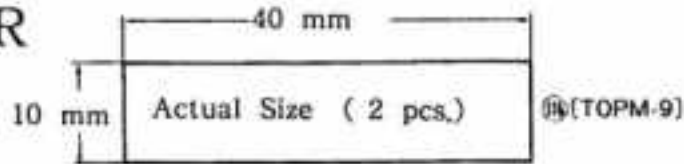

Step 2

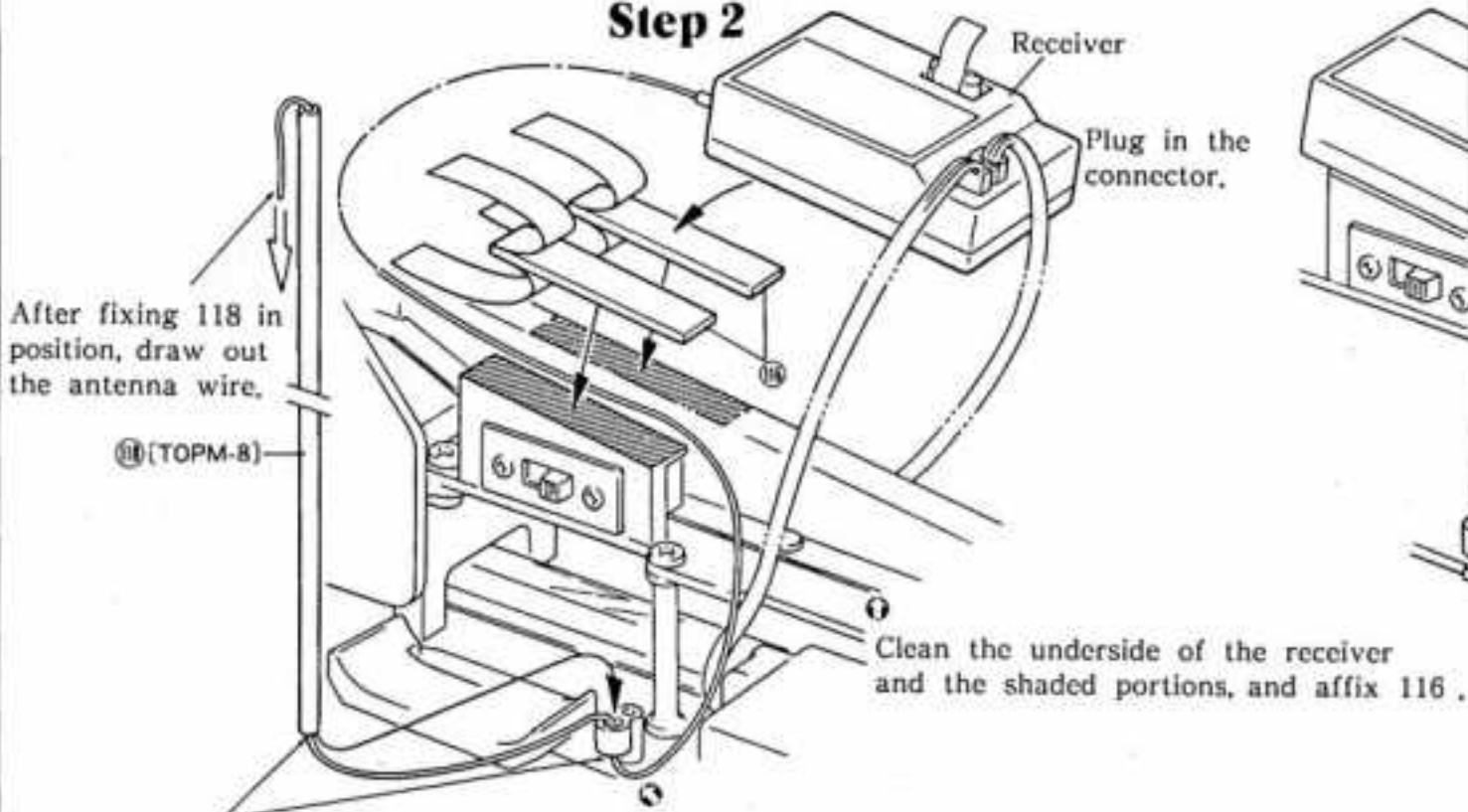

Pass the antenna through the pipe.

Step 3

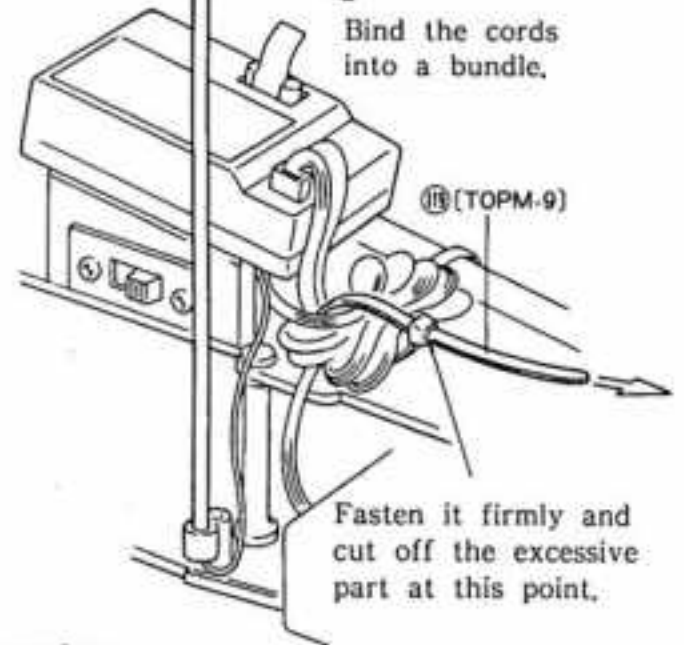

33 INSTALLATION OF WING STAY

*All the parts, except screws, used in this step are packed in (TOPM-6).

<Preparation of Stabilizer Stopper>

Try to put up the wing stay A 120 and 121 ; and if you find it rub against the stoppers, cut off the part as indicated in the illustration.

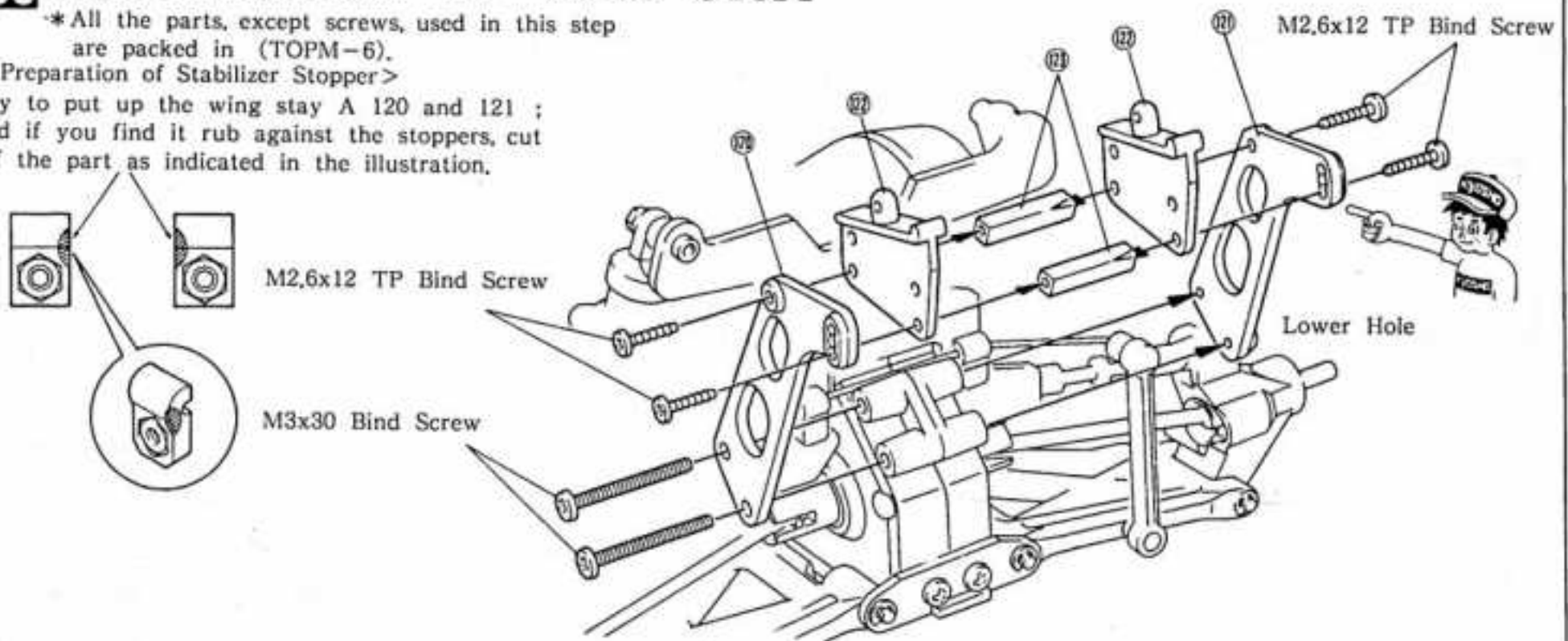

34 ASSEMBLY OF TIRE AND WHEEL

<Sectional View of Tire and Wheel Fitted>

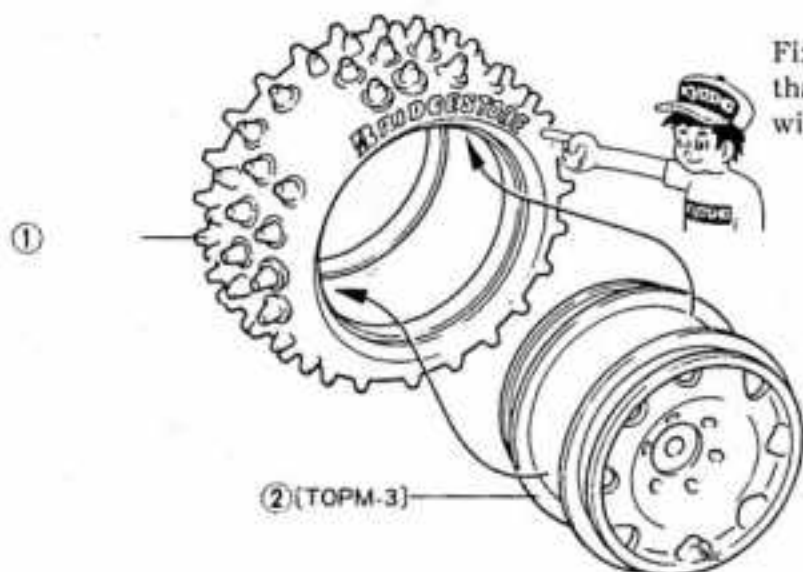

Fix the tire in such a way that the molded description will face toward the outside.

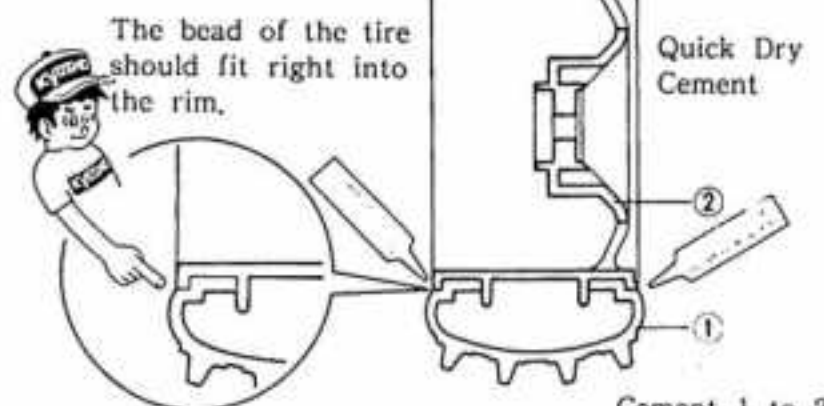

35 INSTALLATION OF TIRES

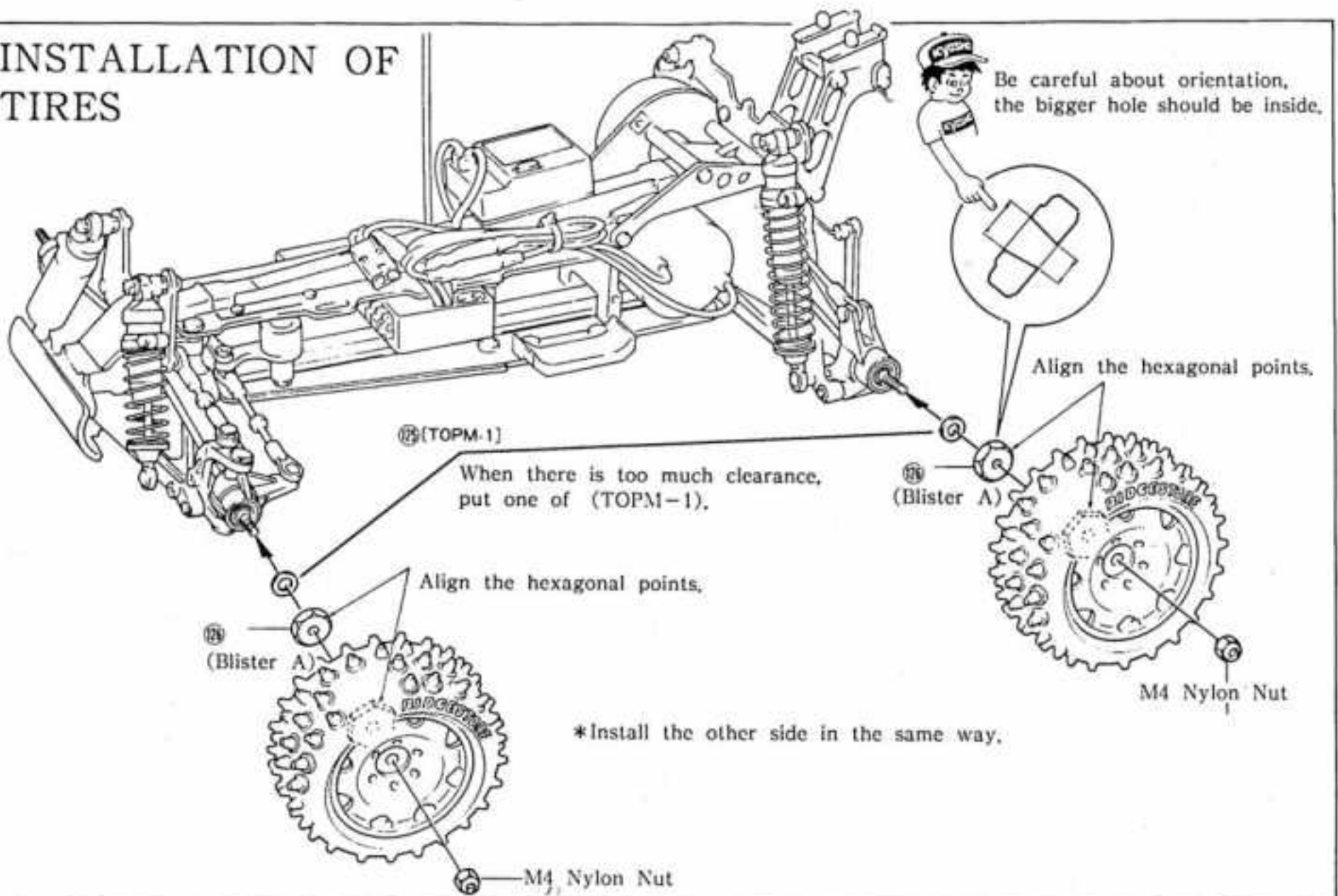

36 CUTTING OF BODY AND WING

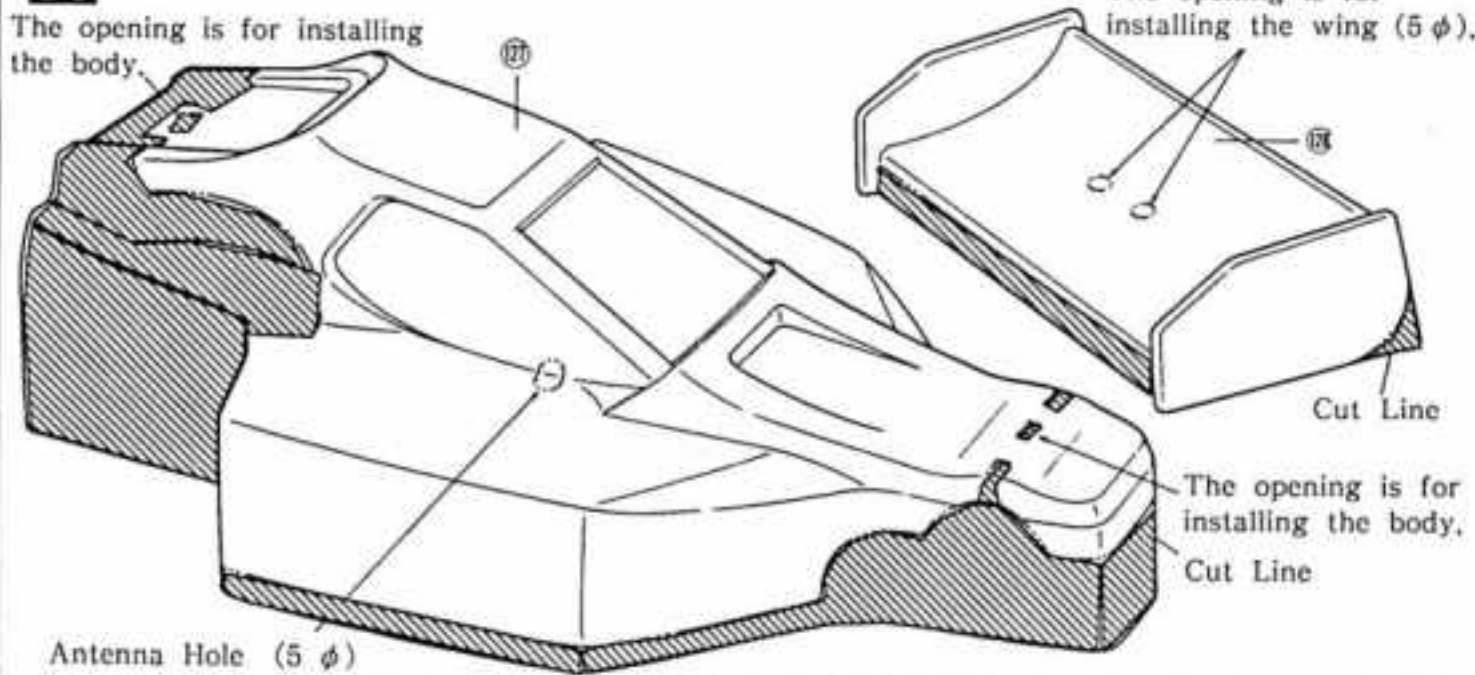

KYOSHO NO.1829

These special Lexan Scissors make trimming bodies a breeze and the sander comes in handy for finishing the rough edges.

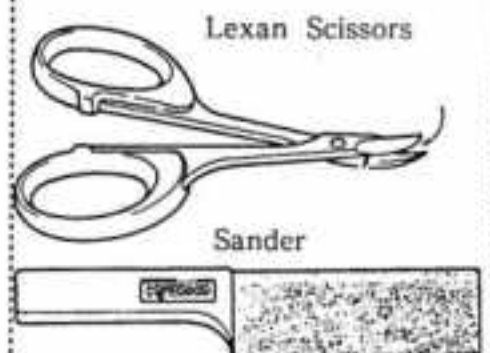

Finish the cuts smoothly with the Sander.

37 PAINTING

First, wash the body to remove any oil or dirt. Rinse thoroughly. Paint the inside of the body. You can obtain a color scheme by masking a portion with tape then removing the tape and painting. Apply the lightest color last.

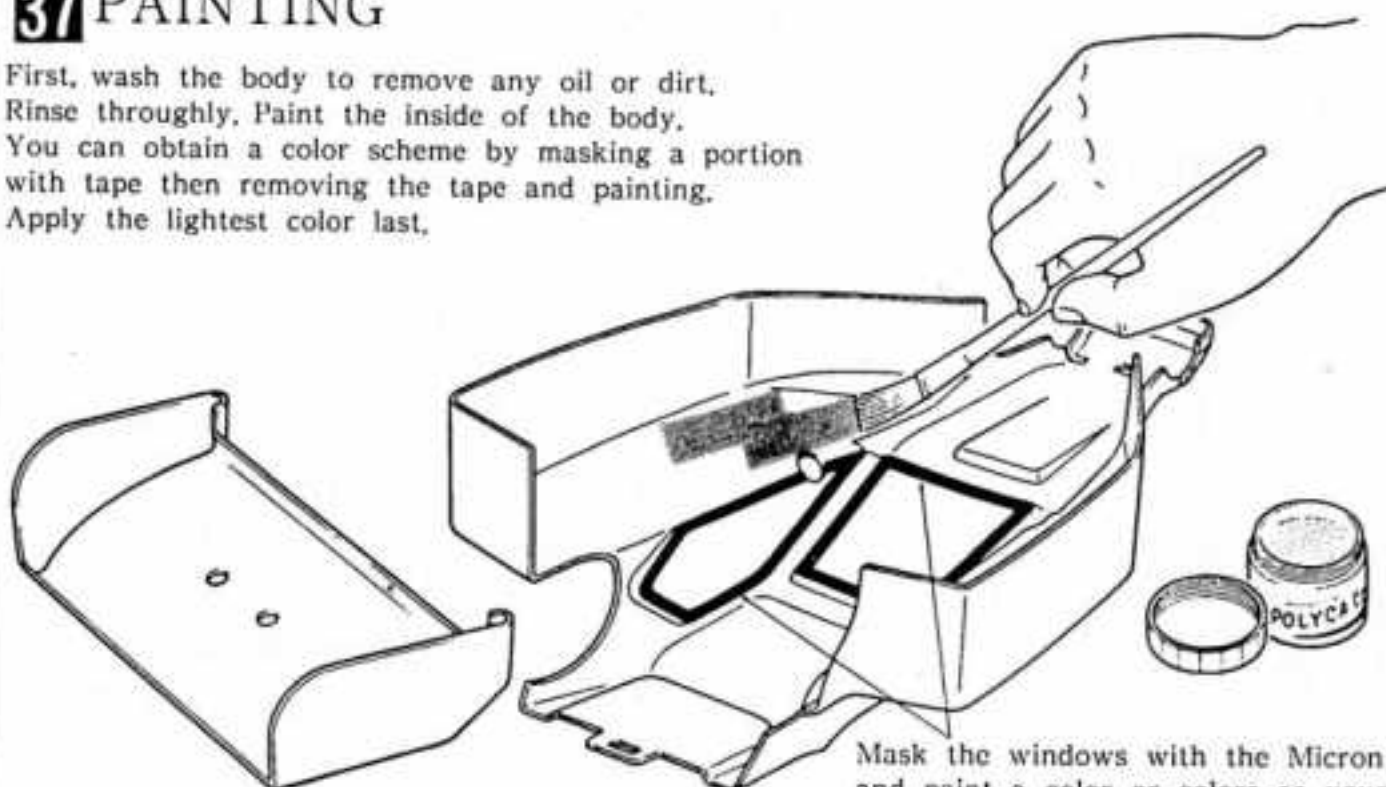

KYOSHO

Micron Line Tape
NO.1841 ... 1mm
1842 ... 1.5mm
1843 ... 2.5mm

Color
White, Red, Yellow
Green, Blue, Black



KYOSHO

Polyca Color
NO.2230
Color
White, Red, Yellow
Green, Blue, Sky Blue
Orange, Black, Violet
F, Pink, F, Orange,
Yellow Green



Mask the windows with the Micron Tape and paint a color or colors as your choice.

38 APPLYING DECALS

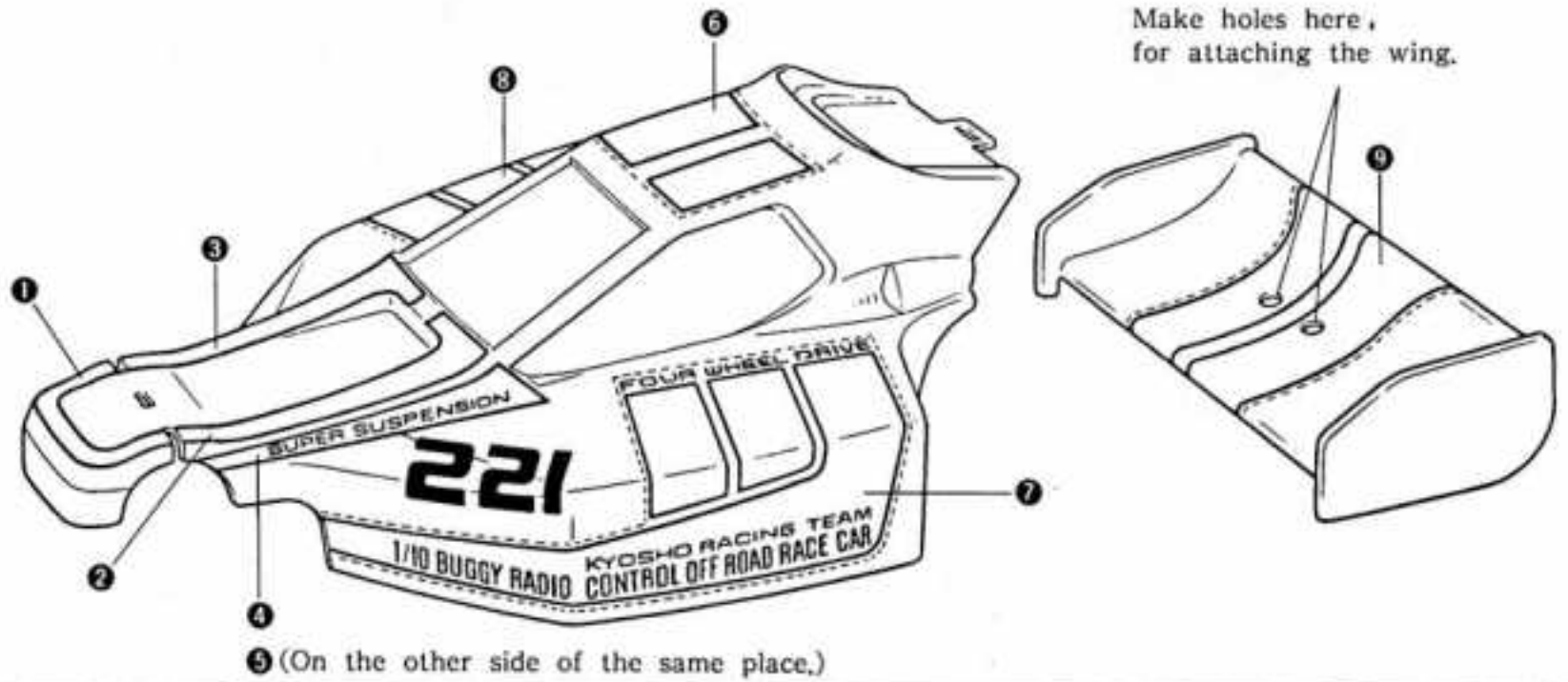

Make holes here, for attaching the wing.

9 (On the other side of the same place.)

39 MOUNTING OF BATTERY

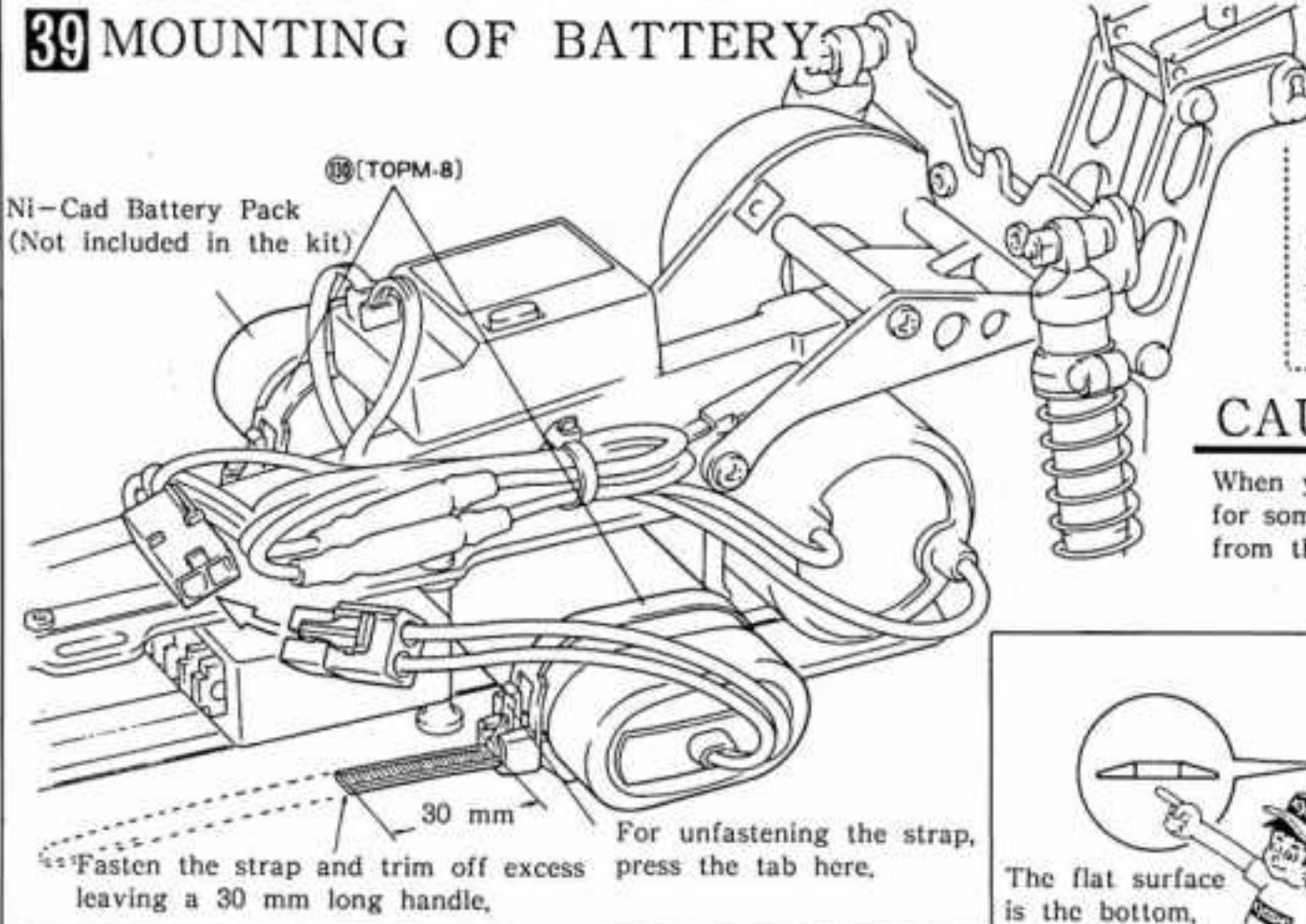

KYOSHO NO. 2310



For maximum performance, use a high performance battery. The Kyosho 7.2V Sprint Battery SCR is recommended.

CAUTION!

When you keep the model not running for some time or stored, remove the battery from the model without fail.

40 INSTALLATION OF BODY AND WING

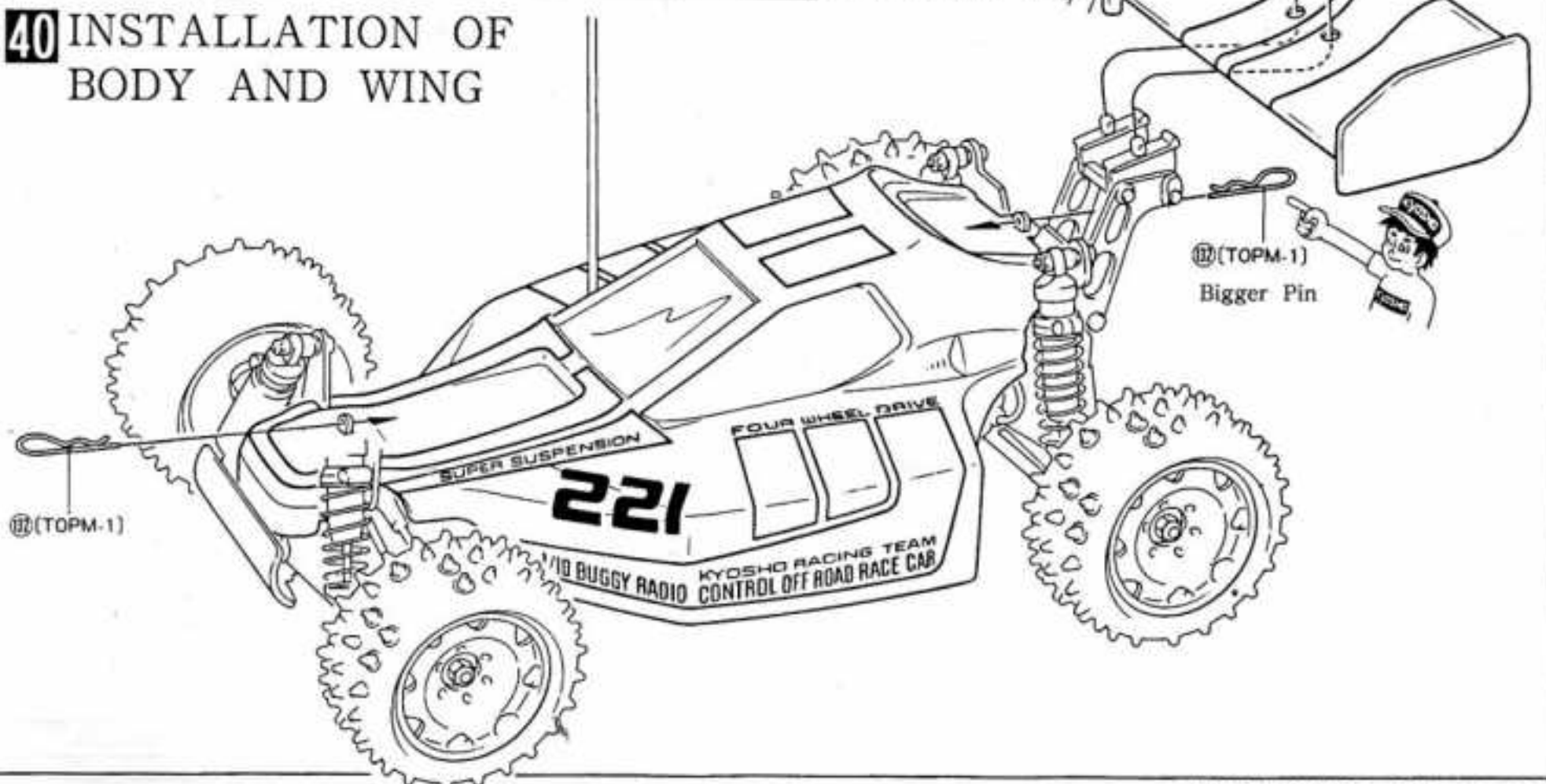

Guide for Characterizing "Turbo Optima Mid" (1)

(Basic Setting 1)

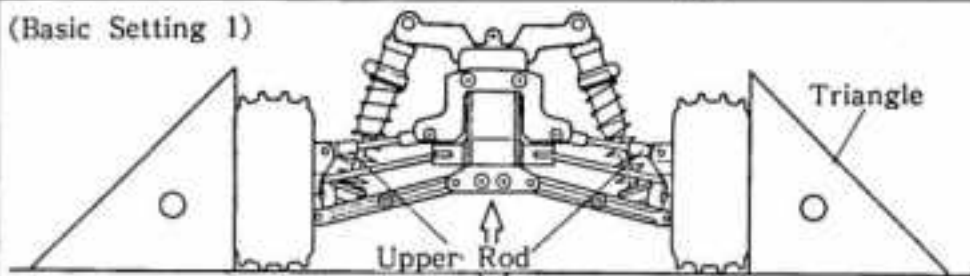

Place the model car on a flat surface, and keep the car with the maximum body clearance, and adjust length of the front and rear upper rods so that the wheels stand at a right angle to the ground.

(Adjustment of Upper Rod)

To get rod longer: Turn wrench forward.

To get rod shorter: Turn wrench reverse.

*Tie rod can be adjusted in the same way.

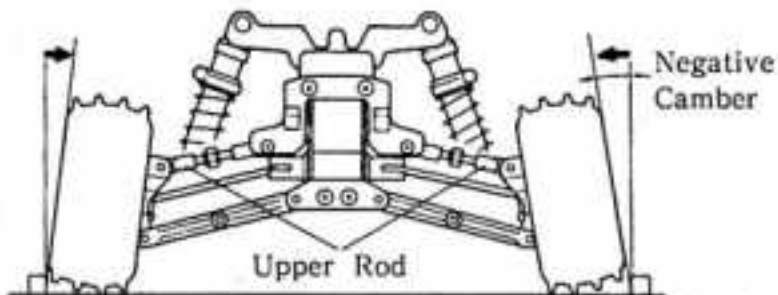
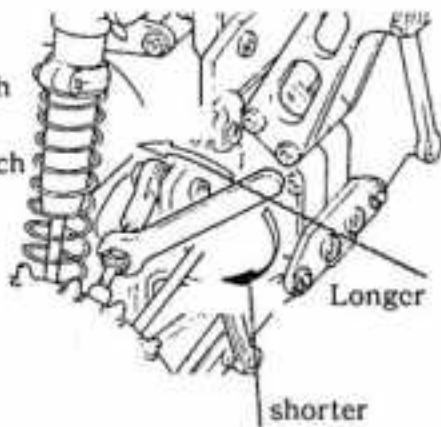

By adjusting the upper rod shorter, you will have a trait of negative camber. With negative camber adjustment of the front wheels, you will have sharper steering tendency, while on the rear wheel the gripping power becomes higher.

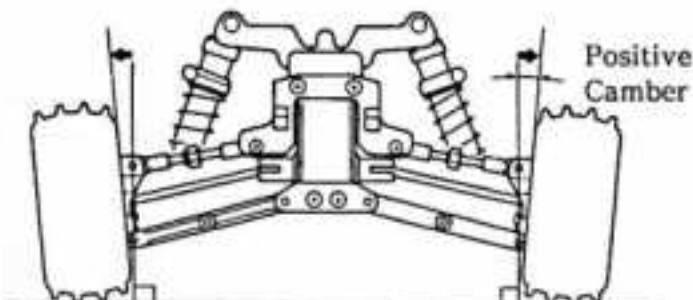

By lengthening the upper rod, positive camber adjustment is gained. With positive camber on the front wheels, you will have a trait of under steering, while on the rear wheels you will have the car with over steering traits.

*Excessive positive camber adjustment may make the swing shaft dislocated.

(Basic Setting 2)

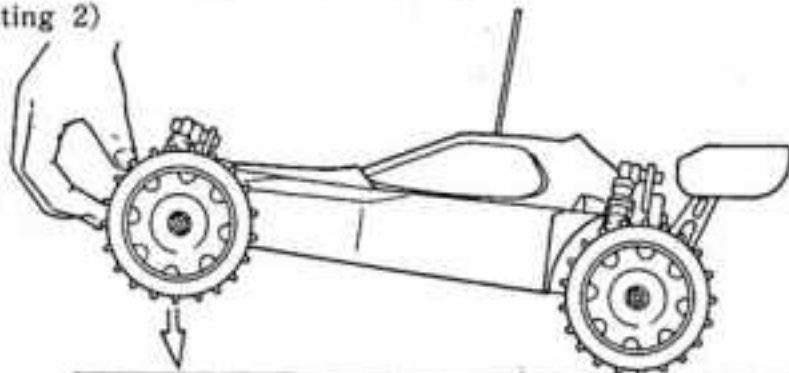

Adjust the right and left shocks in such a way that both sides of the front wheels will touch down the ground simultaneously when raising the front portion of the model and lowering it down gently. In the case the right and left side wheels land not in the same instant, the steering of each wheel will differ.

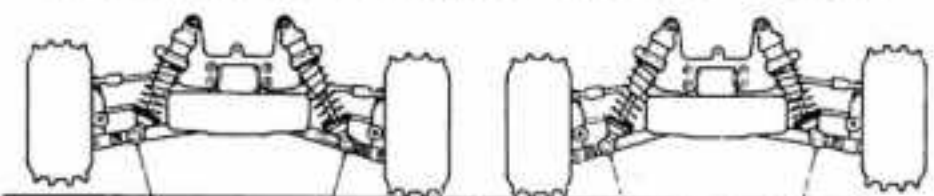

Adjust it longer, Make it shorter.

Adjust it shorter, Make it longer.

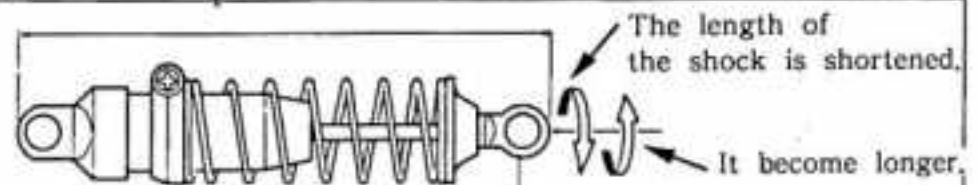

*Turn the shock end in or out for the adjustment.
(Selection of Shock Oil and Adjustment of Spring)

Front	With lighter shock oil Lesser spring tension	→ Sharper steering response
Front	With heavier shock oil Harder spring tension	→ Slower steering response
Rear	With lighter shock oil Lesser spring tension	→ Higher gripping power
Rear	With heavier shock oil Harder spring tension	→ Lower gripping power

(Landing Attitude After a Leap)

Harder spring tension of the front shocks and lighter oil in them will prevent a head down crash landing.

(Adjustment of Hardness of Shock Action)

NO.1951 Oil Set	Yellow	Green	Yellow	Red	Green	Red
Piston						
Hardness	← Harder			Softer →		

*Take this chart just as general indication.

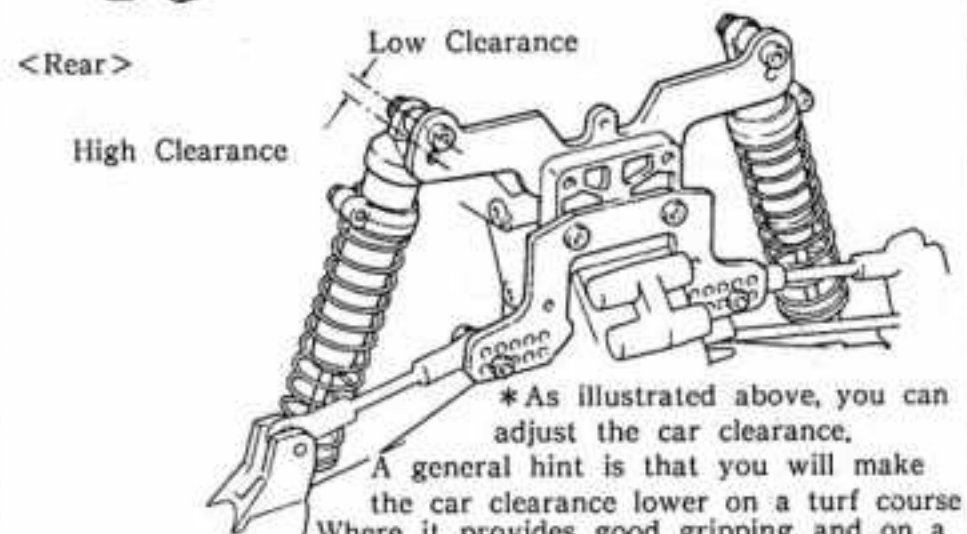
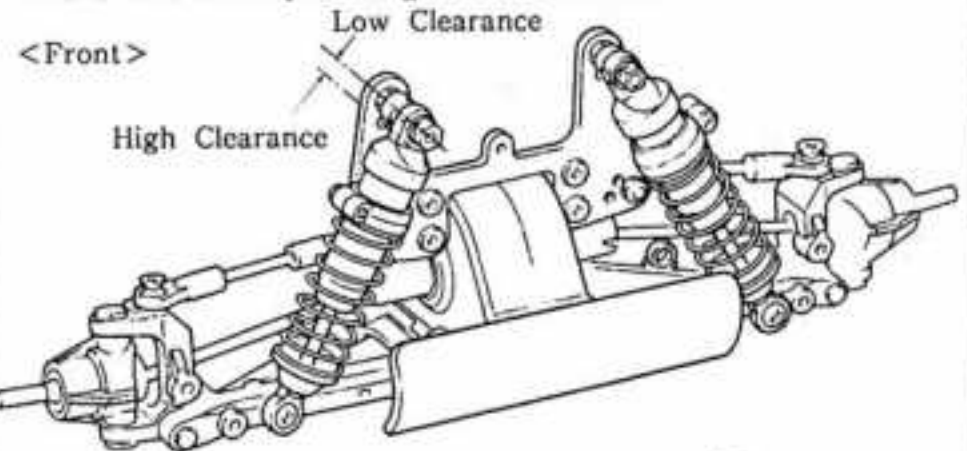

*As illustrated above, you can adjust the car clearance.

A general hint is that you will make the car clearance lower on a turf course where it provides good gripping, and on a track which gives you poor gripping you will set the clearance higher.

(Gear Protector)

This function is to protect gear from emergent shock when after jump or crashed in accident. When the car is started, the gear tends to skid, then be sure to tighten M3 nylon nut a quarter of turn at each time. Otherwise shall take some trouble causing by heat. M3 nylon nut which put in at step 4 on page 4.

(Gear Ratio and Optional Motors)

PinionGear	15	16	17	18	19	20	21	22	23	24	25
Gear Ratio	13.04	12.22	11.50	10.87	10.29	9.78	9.31	8.89	8.50	8.15	7.82
Proper Motor	SPA 240 WS										
							Le Mans H-240S				
					Le Mans 240ST						
								Le Mans 360Gold			

Guide for Characterizing "Turbo Optima Mid" (2)

(Modification of Tire)

By changing the shape of the knobs on the tire, you can improve the running performance of the car.

*If your car displays the quick steering response, cut off the knobs by 1/2 to 1/3 then you can make it with milder response.

Let the knobs down,

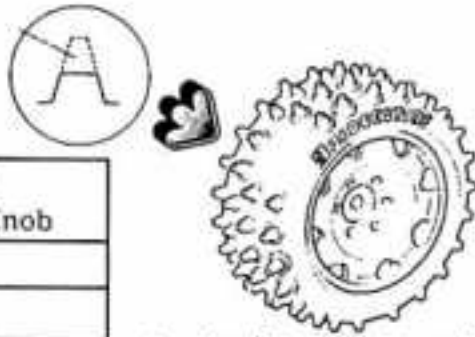

Type of Course Surface	Amount of Lowering Knob
Turf	Cut 1/2
Concrete	Cut 2/3
Sandy	No Cutting
Hard Dirt Track	Cut 1/3
Soft Dirt Track	No Cutting

*In the "Option House" series, the W5031 Low Profile Tire (for hard surface) and the W5032 (for soft surface) are available.

(Adjustment of Differential Gear)

The working of the differential gear system depends on amount and viscosity of the oil in the system. When you like to make it heavier, put more the 1952 Differential Oil, and to the other way, mix 10 % to 20 % shock oil with the differential oil in the system.

(Change of Steering Characteristics by Adjustment of Differential)

Adjustment of Differential	Steering Trait at Low Speed Cornering	Steering Trait at High Speed Cornering
Front Differential (Heavier)	Neutral Steering	Under Steering
Rear Differential (Heavier)	Under Steering	Over Steering
Both Front and Rear (Lighter)	Over Steering	Neutral Steering

*This is just a rule of thumb.

Step 1

Take off the screw and E ring which illustrated in a red color.

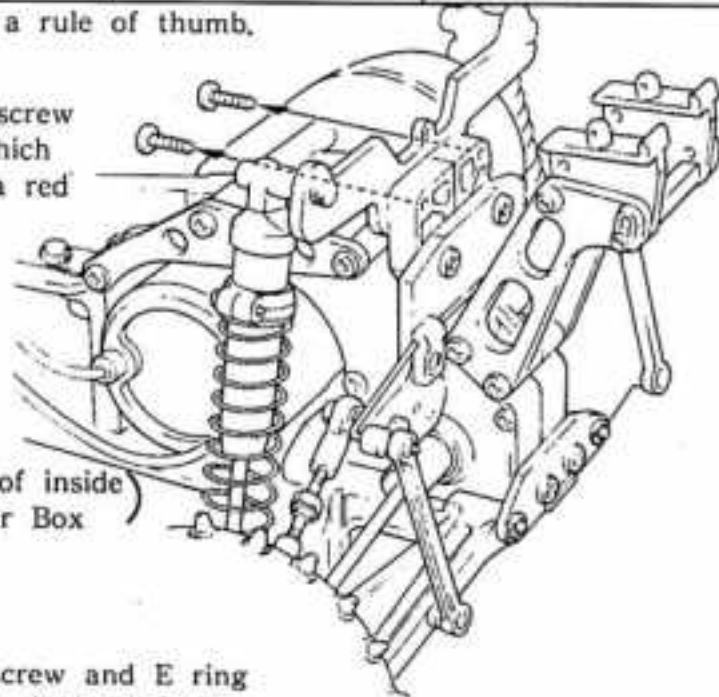

(Maintenance of inside the Rear Gear Box)

Step 2

Take off the screw and E ring indicated below. And take off a motor too.

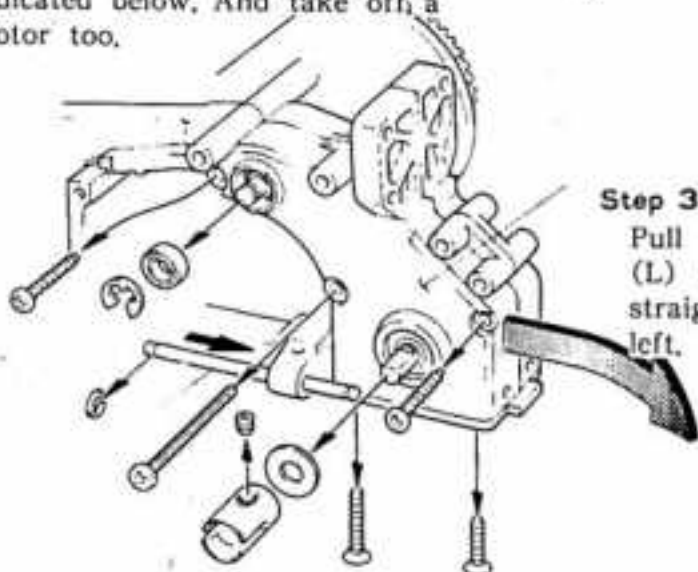

Step 3

Pull Rear Gear Box (L) back keeping straight and turn it left.

(Maintenance of Sprocket)

Dust or other foreign articles are subject to be accumulated on cogs of the sprocket in front and rear. Check them from time to time.

(Correlation between the Position of Front Upper Rod and Camber Angle)

The installing points A, B, and C on the front shock stay for the upper rod correspond to A', B' and C' which are the maximum camber angle when the front suspension arms swing down to the lowest position.

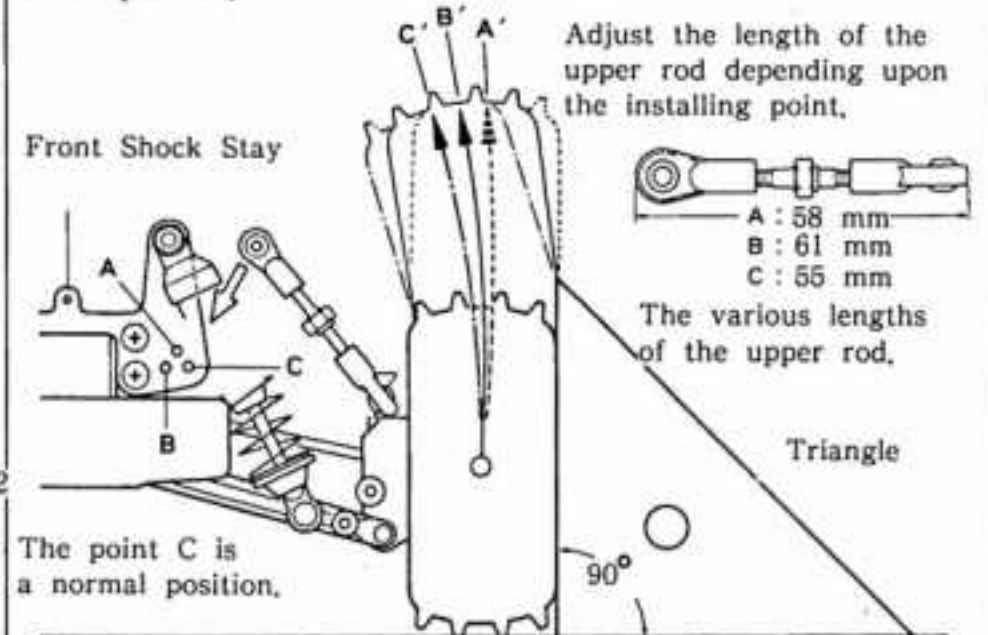

The point C is a normal position.

(Correlation between Installing Position of the Rear Upper Rod and Camber Angle)

The installing points A, B, C and D on the upper rod plate will result in the positions of the rear camber angle A', B', C' and D' when the rear suspension arms sink the most.

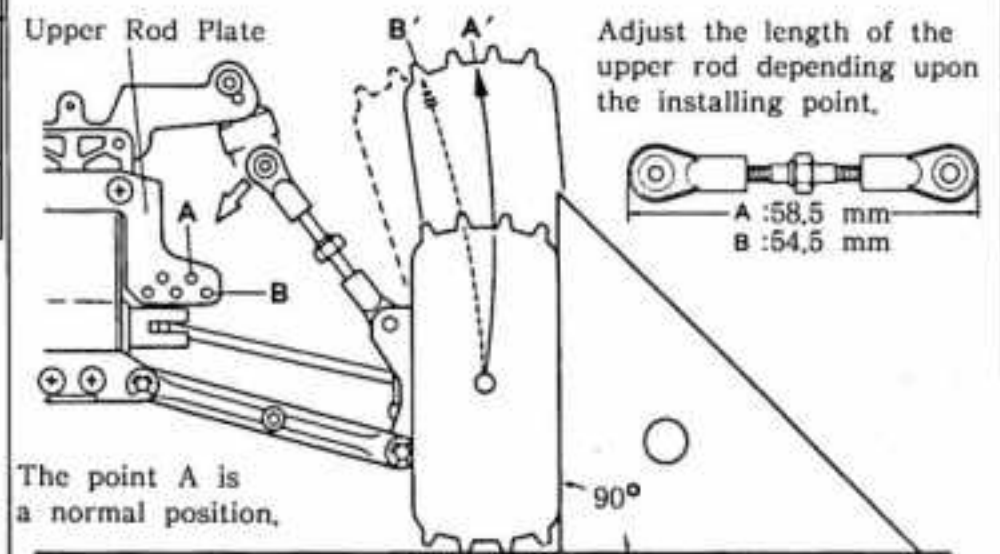

The point A is a normal position.

(Adjustment of Belt tension)

This model is so designed that the belt is engaged rather tightly. If you find it too tight to let it go smoothly, enlarge the hole on the upper deck toward the front end, and reassemble it by pushing the front gear box from the front and tightening the screw.

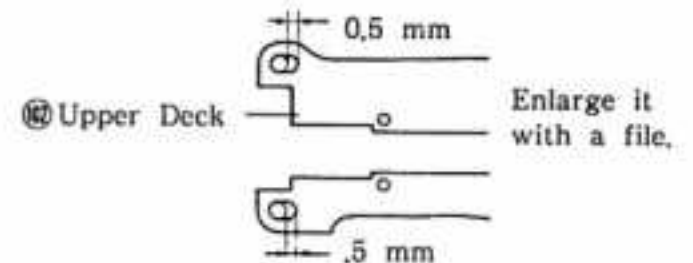

(Adjustment of Wing Stay)

When fastening the wing stay B to the wing stay A, the assembled angle of the two components will be bigger in order from A to B to C fixing points.

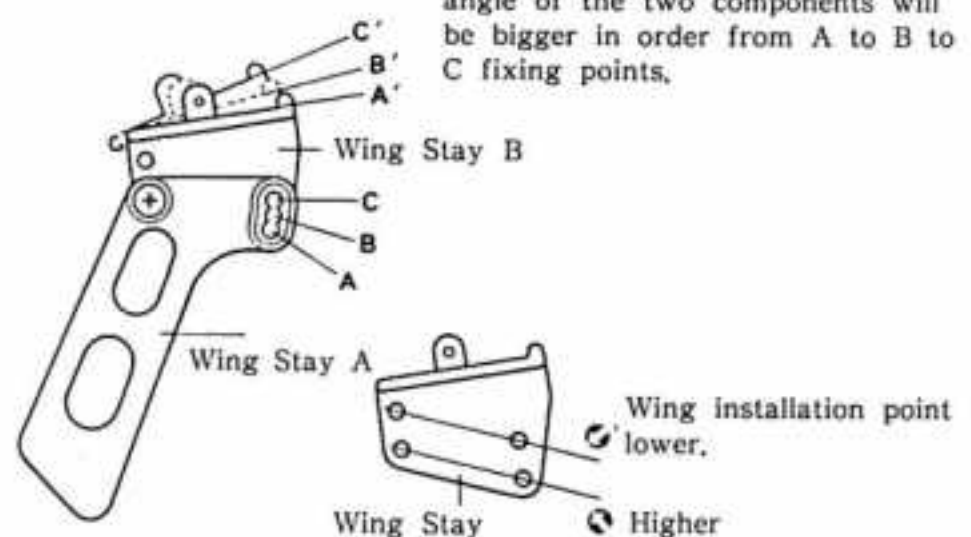

Things to Observe

(Running the Turbo Optima Mid)

This model has only Ni-Cad battery powering the motor, receiver and servos at a time. Whenever you notice the car losing the speed, discontinue the operation, otherwise your car will out of control.



(After Running)

After you had a pleasure of running your car, unplug the connector from the battery. And store the battery separately from the model.

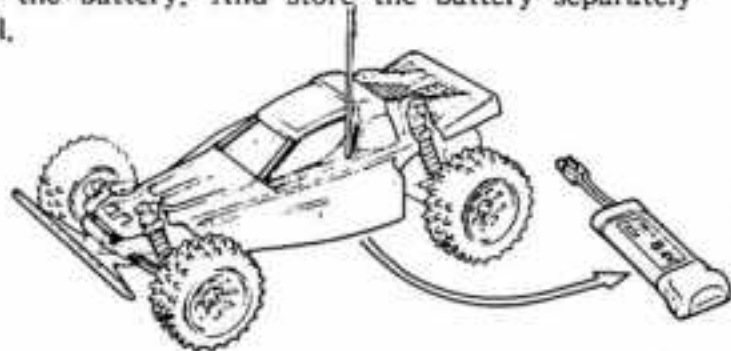

(Checking Your Car before Running)

*When you have your car run for the first time, drive it slowly for the duration of one to three charges of the Ni-Cad battery.

- (1) Check to see if all bolts and nuts are tightened firmly.
- (2) Check to see if Ni-Cad battery is fully charged.
- (3) Check to see if the steering and the speed control is in proportion to your control of the transmitter.
- (4) Check to see if all wiring are properly secured.
- (5) Check to see if all rotating parts move smoothly.

(Operation Procedures)

- (1) Turn on the switch of the transmitter.
- (2) Turn on the switch of the receiver.
- (3) Test the operation of the radio control units.

*When turning off the switch, turn off the receiver first, then the transmitter. If you don't keep this order, your model may start to run haphazardly.

(Trouble Shooting)

- (1) Poor contact of batteries, connectors, and speed controller.
- (2) Check to see if the Ni-Cad battery is properly charged.
- (3) Check to see shortage of battery power for the transmitter.
- (4) Check to see if there is no signal interference by other radios.

Dos and Don'ts for Operation

Radio controlled model cars are powered by high effective Ni-Cad battery and can attain great speed. You are required to be very careful in handling them.

- Do not use the streets for running model cars.
- Two cars under the same frequency cannot run at a time. When there is another model going in the same time, compare the frequency of your radio with his.
- When your car stalled, or being caught by some obstacles, do not continue running forcibly. The motor and wiring may be burnt down or damaged.
- Do not grab the rotating wheel.
- Before connecting the Ni-Cad battery, confirm that the speed controller is positioned in neutral.
- If the bearing in the driving train do not rotate smoothly, the motor and battery may be loaded excessively, resulting in losing speed or overheating. Check always that the drive train will turn lightly and grease the bearings from time to time.
- The car with one battery for both motor and radio units will lose control as the battery power is falling. When the car slows down, stop the running.

Maintenance after Running The Car

- Remove the Ni-Cad battery from the car.
- Wipe dirt and oily stain off the car.
- Turn off the switches of the radio control units.
- Grease the moving parts periodically.
- Tighten the loose screws and nuts, if any.

Handling the Motor

- The motor generates heat while it is running. A continuous running of the motor may shorten its span of life. Do not operate the motor until it cools off.
- Several times of running of the motor will decrease the power, since carbon has been accumulated on the commutator. Remove the pinion gear and run the motor without load under 7.2 volts for about 15 minutes for cleaning the commutator.
- Oil the motor bearings at regular intervals.

Exploded View of Front & Rear Differential Gears

Front Differential Gear

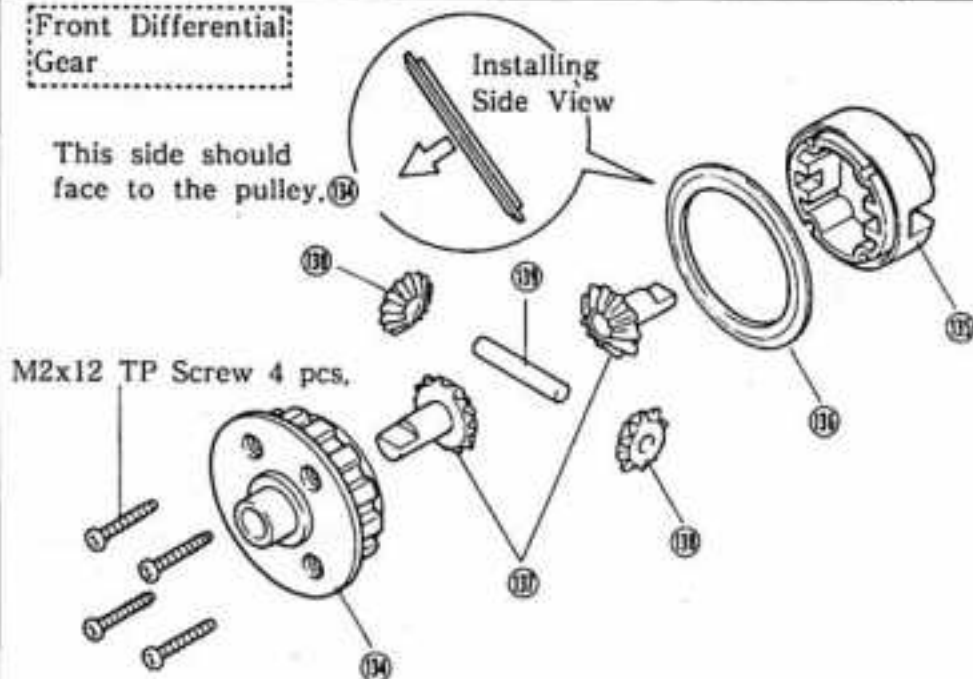

Rear Differential Gear

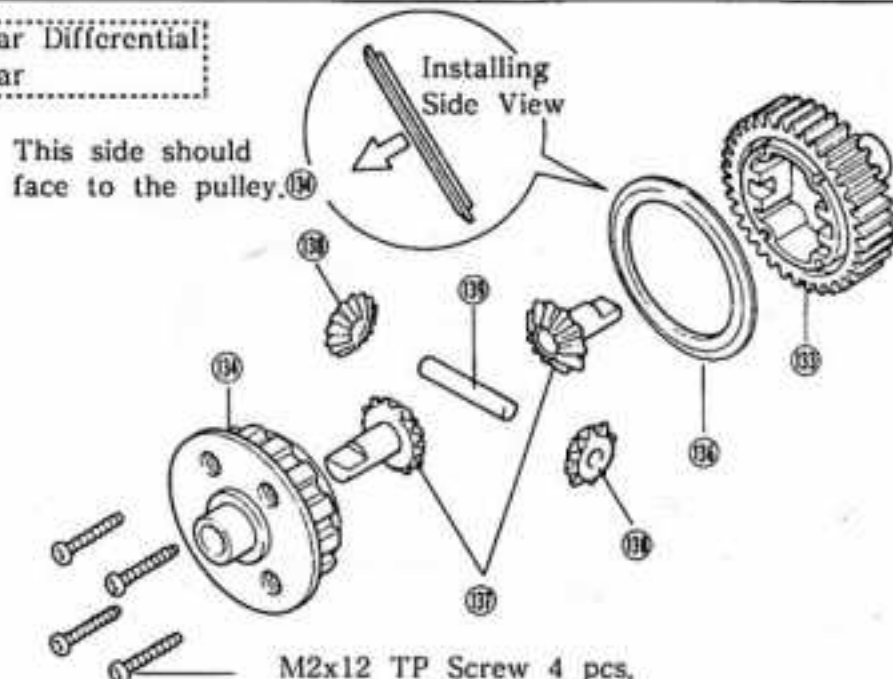

"TURBO OPTIMA MID" KEY NUMBERS FOR PARTS

NO.	PARTS NAME	Q'TY	NO.	PARTS NAME	Q'TY	NO.	PARTS NAME	Q'TY
1	Tire	4	52	King Pin	4	103	Switch Plate	1
2	Wheel	4	53	5.8 φ Ball (Silver)	4	104	Belt Cover (B)	1
3	8 φ x14 Ball Bearing	4	54	Front Suspension Arm	2	105	M2 Shaft	2
4	Joint	4	55	M3 Pillow Ball (Silver)	4	106	Rubber Cover	1
5	Allen Wrench (2 mm)	1	56	Front Stabilizer End	2	107	Belt Cover (C)	1
6	Rear Gear Box (R)	1	57	E Ring (E-3) (Black)	2	108	Allen Wrench (1.5 mm)	1
7	5 φ x10 Ball Bearing	10	58	Suspension Shaft (A)	2	109	Motor Cord	2
8	Spur Gear Shaft	1	59	Suspension shaft (B)	2	110	Motor Spacer	2
9	2 φ x11 Pin	2	60	E Ring (E-2.5)	20	111	Motor Cover	1
10	Counter Gear	1	61	5.8 φ Ball (Black)	4	112	Motor Cleaner	1
11	E Ring (E-4)	4	62	Allen Wrench (2.5 mm)	1	113	Motor Plate	1
12	5 φ x8 Ball Bearing	2	63	Ball End (L)	12	114	Pinion Gear (20T)	1
13	Pulley (Yellow)	1	64	Upper Rod	4	115	Gear Cover	1
14	Pulley Flange (Yellow)	1	65	Rear Hub (R)	1	116	Double Sided Tape	1
15	5 φ Collar (S) (Yellow)	2	66	Rear Hub (L)	1	117	Antenna Post	1
16	4 φ x8 Ball Bearing	2	67	Rear Shaft	2	118	Antenna Pipe	1
17	Center Gear	1	68	Rear Suspension Arm	2	119	Strap (S)	3
18	Center Gear Shaft	1	69	Suspension Shaft (C)	2	120	Wing Stay (A) (L)	1
19	Toothed Belt	1	70	Suspension Shaft (D)	2	121	Wing Stay (A) (R)	1
20	Rear Gear Box (L)	1	71	Rear Suspension Plate	1	122	Wing Stay B	2
21	Rear Plate (L)	1	72	Swing Shaft	2	123	Wing Stay Joint	2
22	Rear Plate (R)	1	73	Shock Oil	1	124	Wing Washer	4
23	5 φ Collar (L) (Yellow)	1	74	Front Shock Case	2	125	5 φ Shim	8
24	Gear Protector Plate (B)	1	75	Rear Shock Case	2	126	Driver Washer	4
25	Gear Protector Washer	2	76	Shock Piston	4	127	Body	1
26	Spur Gear	1	77	Front Shock Shaft	2	128	Wing	1
27	Gear Protector Plate (A)	1	78	Rear Shock Shaft	2	129	Decal	1
28	Wave Washer	3	79	Shock O Ring (Red)	8	130	Ni-Cad Strap	2
29	Gear Protector Collar	1	80	Shock Collar (White)	4	131	Wing Pin	2
30	Upper Rod Plate	1	81	Plastic Washer (Black)	4	132	Body Pin	2
31	Rear Shock Stay	1	82	C Ring	4	133	Main Gear	1
32	Front Gear Box (R)	1	83	Shock Cap	4	134	Sprocket	2
33	Front Gear Box (L)	1	84	Pressure Top	4	135	Differential Gear Case	1
34	Front Shock Stay	1	85	Spring Stopper	4	136	Diff. Gear Ring (Yellow)	2
35	Front Suspension Plate	1	86	Shock End	4	137	Bevel Gear (A)	4
36	Chassis	1	87	Front Spring	2	138	Bevel Gear (B)	4
37	Bumper	1	88	Rear Spring	2	139	Bevel Shaft	2
38	Belt Cover (A)	1	89	Spring Holder	4	140	M3 Plastic Nut	4
39	One Touch Tape	2	90	Shock Bushing	4	141	Silicone Grease	1
40	Sponge Tape	2	91	Ball End (S)	3	142	Screw Locking Compound	2
41	Saver Shaft	2	92	Ball Nut	3	143	Front Stabilizer	1
42	Upper Deck Post	2	93	Servo Saver (A)	1	144	Rear Stabilizer	1
43	Upper Deck Mount	1	94	Servo Saver (B)	1	145	4.8 φ Ball	2
44	Rear Suspension Pivot	1	95	Servo Saver (C)	1	146	Stabilizer Stopper	2
45	Battery Holder	2	96	Servo Saver (D)	1	147	Stabilizer Pillow Ball	2
46	Knuckle Arm (L)	1	97	Servo Saver Collar	2	148	Stabilizer Ring	2
47	Knuckle Arm (R)	1	98	Tie Rod	2	149	Stabilizer End Ball	2
48	Universal Swing Shaft	2	99	Steering Rod	1			
49	M2.6 Pillow Ball (Black)	4	100	Servo Stay	4			
50	Front Hub (R)	1	101	Servo Stay Spacer	2			
51	Front Hub (L)	1	102	Upper Deck	1			

"TURBO OPTIMA MID" BAGGED PARTS LIST (1)

BAG.	NO.	PARTS NAME	Q'TY	STEP
Blister (A)	4	Joint	4	1
	10	Counter Gear	1	2
	17	Center Gear	1	2
	19	Toothed Belt	1	2
	26	Spur Gear	1	4
	114	Motor Pinion Gear (20T)	1	10
	126	Drive Washer	4	15
		Front Differential Gear	1	1
		Rear Differential Gear	1	1
		Pressure Oil Shock (S)	2	19
	Pressure Oil Shock (L)	2	19	
Blister (B)	3	8 φ x14 Ball Bearing	4	1
	7	5 φ x10 Ball Bearing	10	2 11 14
	12	5 φ x8 Ball Bearing	2	2
	16	4 φ x8 Ball Bearing	2	2
	36	Chassis	1	7
	46	Knuckle Arm (L)	1	11
	47	Knuckle Arm (R)	1	11
	48	Universal Swing Shaft	2	11
67	Rear Shaft	2	14	
TOPM-1		Screw Set (See Page 23)		
TOPM-2	6	Rear Gear Box (R)	1	2
	20	Rear Gear Box (L)	1	2
	32	Front Gear Box (R)	1	6
	33	Front Gear Box (L)	1	6
	60	E Ring (E-2.5)	4	19
	73	Shock Oil	1	20
	76	Shock Piston	4	19
	79	Shock O Ring (Red)	8	19
	80	Shock Collar (White)	4	19
	81	Plastic Washer (Black)	4	19
	82	C Ring	4	19
	84	Pressure Top	4	20
		Cap Bolt M3x18	4	5 6
	141	Silicone Grease	1	
142	Screw Locking Compound	2		
TOPM-3	2	Wheel	4	
TOPM-4	8	Spur Gear Shaft	1	2
	9	2 φ x11 Pin	2	2
	18	Center Gear Shaft	1	2
	24	Gear Protector Plate (B)	1	4
	25	Gear Protector Washer	2	4
	29	Gear Protector Collar	1	4
41	Saver Shaft	2	9	

BAG.	NO.	PARTS NAME	Q'TY	STEP
TOPM-4	52	King Pin	4	11
	61	5.8 φ Ball (Black)	4	13 16
	64	Upper Rod	4	13 16
	92	Ball Nut	3	17
	98	Tie Rod	2	18
TOPM-5	21	Rear Plate (L)	1	3
	22	Rear Plate (R)	1	3
	27	Gear Protector Plate (A)	1	4
	30	Upper Rod Plate	1	3
	31	Rear Shock Stay	1	5
	34	Front Shock Stay	1	6
	35	Front Suspension Plate	1	6
	71	Rear Suspension Plate	1	15
	113	Motor Plate	1	10
	TOPM-6	13	Pulley (Yellow)	1
14		Pulley Flange (Yellow)	1	2
15		5 φ Collar (S) (Yellow)	2	2
23		5 φ Collar (L) (Yellow)	1	4
37		Bumper	1	18
43		Upper Deck Mount	1	9
44		Rear Suspension Pivot	1	9
45		Battery Holder	2	10
50		Front Hub (R)	1	11
51		Front Hub (L)	1	11
56		Front Stabilizer End	2	12
65		Rear Hub (R)	1	12
66		Rear HUB (L)	1	12
90		Shock Bushing	4	22
93		Servo Saver (A)	1	17
94		Servo Saver (B)	1	17
95		Servo Saver (C)	1	17
96		Servo Saver (D)	1	17
97		Servo Saver Collar	2	18
100		Servo Stay	4	25 31
101	Servo Stay Spacer	2	26	
103	Switch Plate	1	27	
110	Servo Spacer	2	31	
117	Antenna Post	1	28	
120	Wing Stay (A) (L)	1	33	
121	Wing Stay (R)	1	33	
122	Wing Stay (B)	2	33	
123	Wing Stay Joint	2	33	
124	Wing Washer	4	40	
140	M3 Plastic Nut	4	22	

"TURBO OPTIMA MID" BAGGED PARTS LIST (2)

BAG.	NO.	PARTS NAME	Q'TY	STEP
TOPM-7	49	M2.6 Pillow Ball (Black)	4	11 17
	53	5.8 φ Ball (silver)	4	13 16
	55	M3 Pillow Ball (Silver)	4	17 14
	58	Suspension Shaft (A)	2	12
	59	Suspension Shaft (B) (Silver)	2	12
	63	Ball End (L)	12	13 16 18
	69	Suspension Shaft (B) (Black)	2	15
	70	Suspension Shaft (D)	2	15
	91	Ball End (S)	2	17
TOPM-8	38	Belt Cover (A)	1	3
	39	One Touch Tape	2	3
	54	Front Suspension Arm	2	12
	68	Rear Suspension Arm	2	12
	102	Upper Deck	1	27
	104	Belt Cover (B)	1	28
	107	Belt Cover (C)	1	28
	109	Motor Cord	2	28
	111	Motor Cover	1	28
	112	Motor Cleaner	1	28
	115	Gear Cover	1	30
	118	Antenna Pipe	1	32
	130	Ni-Cad Strap	2	33
	143	Front Stabilizer	1	3
	144	Rear Stabilizer	1	3
	145	4.8 φ Ball	2	17
	146	Stabilizer Stopper	2	3
	147	Stabilizer Pillow Ball	2	14
	148	Stabilizer Link	2	16
	149	Stabilizer End Ball	2	15
TOPM-9	40	Sponge Tape	2	9
	42	Upper Deck Post	2	9
	72	Swing Shaft	2	16
	91	Ball End (S)	1	25
	99	Steering Rod	1	25
	106	Rubber Cover	1	23
	116	Double Sided Tape	1	31 32
	119	Strap (S)	3	31 32
	1	Tire	4	34
	127	Body	1	30
	128	Wing	1	35
	129	Decal	1	38
		Instruction	1	

BAG.	PARTS NAME	Q'TY	STEP
TOPM-1	M2.6x4 Bind Screw	4	
	M2.6x6 Bind Screw	7	
	M2.6x12 Bind Screw	4	
	M3x6 Bind Screw	2	
	M3x10 Bind Screw	4	
	M3x30 Bind Screw	2	
	M3x35 Bind Screw	1	
	M3x45 Bind Screw	2	
	M4x12 Bind Screw	2	
	M3x4 Screw	2	
	M3x6 Flat Head Screw	4	
	M3x12 Flat Head Screw	2	
	M2.6x6 TP Bind Screw	3	
	M2.6x12 TP Bind Screw	4	
	M3x6 TP Bind Screw	3	
	M3x10 TP Bind Screw	19	
	M3x18 TP Screw	4	
	M3x6 TP Flat Head Screw	5	
	M3x10 TP Flat Head Screw	11	
	M3x15 TP Flat Head Screw	3	
	M2.6 Nut	16	
	M3 Nut	4	
	M3 Nylon Nut	1	
	M4 Nylon Nut	4	
	M2.6 Washer	8	
	M3 Washer	4	
	M4 Washer	2	
	M5 Washer	4	
	25 5 φ Shim	8	
	28 Wave Washer	3	
	M3x3 Set Screw	3	
	M4x4 Set Screw	4	
	30 E Ring (E-2.5)	13	
	37 E Ring (E-3 Black)	3	
	11 E Ring (E-4)	5	
	39 Wing Pin (S)	2	
	40 Body Pin (L)	2	
	46 M2 Shaft	2	
	48 Allen Wrench (1.5 mm)	1	
	5 Allen Wrench (2.0 mm)	1	
	62 Allen Wrench (2.5 mm)	1	

"TURBO OPTIMA MID" SMALL PARTS (1)

③ Allen Wrench (2.9 mm)....1

④ Allen Wrench (2.0 mm)....1

⑤ Allen Wrench (1.5 mm)....1

1 INSTALLATION OF JOINT

M4x4 Set Screw....4

M5 Washer4

⑧ ϕ x14
Ball Bearing4

④ Joint4

2 ASSEMBLY OF REAR GEAR BOX

M3x18 TP Screw ..2

M4 Washer2

⑦ ϕ x10
Ball Bearing ..2

⑧ Spur Gear Shaft..1

⑨ ϕ x11 Pin1

⑩ Counter Gear.....1

⑪ E Ring (E-4).....2

⑫ ϕ x8
Ball Bearing ..2

⑬ Pulley (A)
(Yellow)1

⑭ Pulley Flange ..1
(A) (Yellow)

⑮ ϕ Collar
(S) (Yellow)1

⑯ ϕ x8
Ball Bearing ..2

⑰ Center Gear
Shaft.....1

3 INSTALLATION OF REAR PLATE

M3x35 Bind Screw..1

M3x45 Bind Screw..2

M2.6x6 Bind Screw..2

M2.6 Nut2

⑱ Stabilizer
Stopper2

4 INSTALLATION OF SPUR GEAR

M3x10
TP Bind Screw ..2

M3 Nylon Nut1

⑲ ϕ Collar
(L) (Yellow)1

⑳ Wave Washer ...3

㉑ Limiter Collar....1

㉒ ϕ Shim.....2

*Use when excessive
plays.

5 INSTALLATION OF REAR SHOCK STAY

M3x10
TP Bind Screw ..2

M3x18 Cap Bolt ...2

M3 Nut2

6 ASSEMBLY OF FRONT GEAR BOX

M3x6
TP Bind Screw ..2

M3x10
TP Bind Screw ...4

M3x18 Cap Bolt ..2

M3x18 TP Screw ..2

M3 Nut2

7 INSTALLATION OF GEAR BOX

M3x10 TP
Flat Head Screw ...5

M3x15 TP
Flat Head Screw ...1

9 INSTALLATION OF UPPER DECK MOUNT

M3x6
Flat Head Screw ..4

M3x10 TP
Flat Head Screw ..4

① Saver Shaft2

⑲ Upper Deck Post..2

10 INSTALLATION OF BATTERY HOLDER

M3x6 TP
Flat Head Screw ...4

M3x10 TP
Flat Head Screw ...2

M3x10 TP
Bind Screw1

11 ASSEMBLY OF KNUCKLE ARM

M2.6 Nut2

⑦ ϕ x10
Ball Bearing4

⑲ M2.6 Pillow Ball..2
(Black)

⑳ King Pin4

12 INSTALLATION OF FRONT SUSPENSION ARM

⑳ M3 Pillow Ball ...2
(Silver)

㉑ Front Stabilizer ...2
End

㉒ E Ring (E-3) ...2
(Black)

㉓ Suspension Shaft (A)...2

㉔ Suspension Shaft...2
(B) (silver)

㉕ E Ring (E-2.5)...6

㉖ ϕ Ball2

13 INSTALLATION OF FRONT UPPER ROD

M2.6x12 Bind Screw 2

M3x12
Flat Head Screw2

M3x15
Flat Head Screw ...2

M2.6 Nut4

㉗ ϕ Ball (Silver) 2





㉘ ϕ Ball (Black) 2

㉙ Ball End (L)4



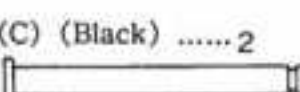
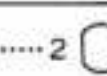

㉚ Upper Rod
.....2

"TURBO OPTIMA MID" SMALL PARTS (2)



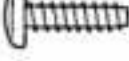



14 INSTALLATION OF REAR HUB

- 7 5 φ x10 Ball Bearing ...4 
- 55 M3 Pillow Ball (Silver) ...2 
- 60 E Ring (E-2.5) ...2 
- 67 Rear Shaft2 
- 69 Suspension Shaft (C) (Black)2 
- 68 Stabilizer Pillow Ball2 

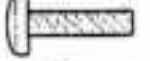



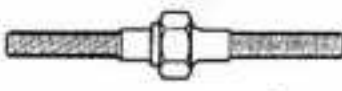

15 INSTALLATION OF REAR SUSPENSION ARM

- M3x10 TP Bind Screw ...2 
- M3x3 Set Screw2 
- 60 E Ring (E-2.5)4 
- 70 Suspension Shaft (D)2 
- 68 Stabilizer End Ball2 



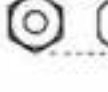

16 INSTALLATION OF REAR UPPER ROD

- M2.6x12 Bind Screw ...2 
- M3x10 Bind Screw ...2 
- M2.6 Nut4 
- 53 5.8 φ Ball (silver)2 
- 61 5.8 φ Ball (Black)2 
- 63 Ball End (L)4 
- 64 Upper Rod2 
- 68 Stabilizer Link2 





17 ASSEMBLY OF SERVO SAVER

- M2.6x6 Bind Screw ...1 
- M2.6 Washer (Black) ...4 
- 49 M2.6 Pillow Ball (Black) ...2 
- 91 Ball End (S)2 
- 92 Ball Nut3 
- 68 M2 Shaft1 

18 INSTALLATION OF SERVO SAVER

- 11 E Ring (E-4) ...2 
- 63 Ball End (L) ...4 
- 97 Servo Saver Collar ...2 
- 98 Tie Rod2 
- 75 5 φ Shim2 

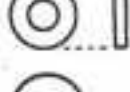

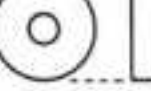
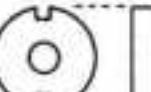
19 ASSEMBLY OF OIL SHOCK

- 60 E Ring (E-2.5)4 
- 79 Shock O Ring (Red) ...8 
- 80 Shock Collar (white) ...4 
- 81 Plastic Washer (Black) ...4 
- 82 C Ring4 
- 76 Shock Piston Front ...2 
- 76 Shock Piston Rear ...2 



20 FILLING OF SHOCK OIL

- 84 Shock Top4 



22 INSTALLATION OF SHOCK

- 90 Shock Bushing4 
- 68 M3 Plastic Nut4 

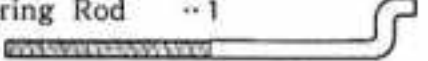
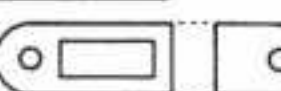

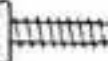

25 INSTALLATION OF STEERING ROD

- M3x10 TP Bind Screw ...2 
- M3 Washer2 
- 91 Ball End (S)1 
- 99 Steering Rod ...1 
- 68 Servo Stay2 



26 INSTALLATION OF STEERING TIE ROD

- M2.6x6 TP Bind Screw ...1 
- M3x10 TP Bind Screw ...2 
- 68 Servo Stay Spacer ...2 
- 68 Antenna Post1 



27 INSTALLATION OF UPPER DECK

- M2.6x6 TP Bind Screw ...2 
- M3x6 TP Bind Screw ...1 
- M3x6 Bind Screw ...2 
- M3x6 TP Flat Head Screw ...1 
- M4x12 Bind Screw ...2 



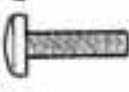

28 INSTALLATION OF BELT COVER (B),(C)

- M2.6x4 Bind Screw ...4 
- M2.6x6 Bind Screw ...4 
- M2.6 Washer4 

30 INSTALLATION OF MOTOR

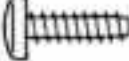
- M3x4 Screw2 
- M3x10 Bind Screw ...2 
- M3x3 Set Screw1 



31 INSTALLATION AMP.

- M3x10 TP Bind Screw ...4 
- M3 Washer2 
- 68 Servo Stay2 
- 68 Servo Spacer2 

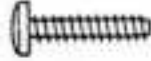
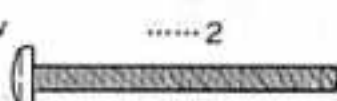

33 INSTALLATION OF WING STAY

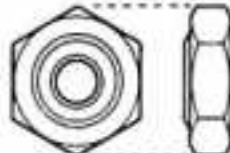
- M2.6x12 TP Bind Screw ...4 
- M3x30 Bind Screw2 

35 INSTALLATION OF TIRE

- M4 Nylon Nut ...4 
- 68 Drive Washer ...4 
- 75 5 φ Shim4 

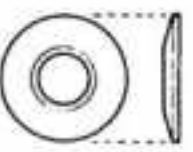
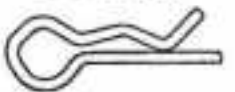









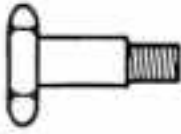
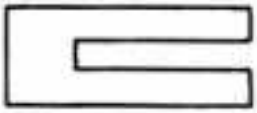

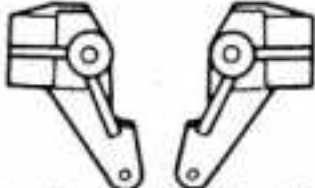
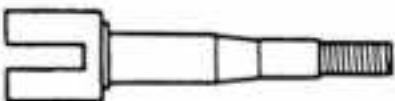



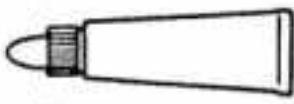

40 INSTALLATION OF BODY AND WING

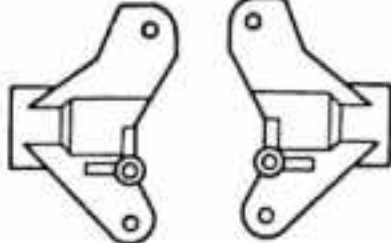
- 68 Wing Washer ...2 
- 68 Wing Pin2 
- 68 Body Pin2 

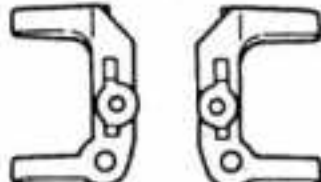
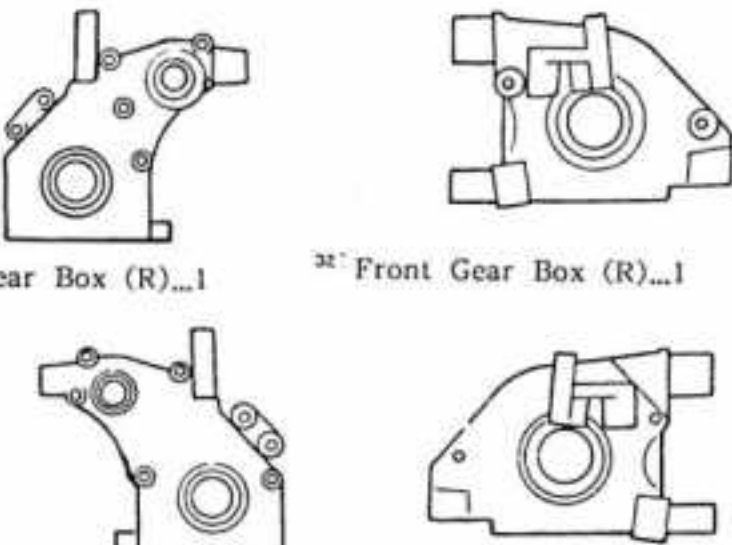
PURCHASING PARTS FOR YOUR KIT

You can purchase replacement and optional parts for your kit. All of the part identified by key numbers (see page 21 for a complete list) are usually not available singularly, but we offer these parts in convenient parts "packs" which can be purchased separately.

To figure out which parts pack you need, find the key number for that part within the manual. Then consult our parts pack guide, below. When referring to the parts you need, always use the parts pack number. For instance, if you need a King Pin (Key No.52) ask your dealer for Kyosho Parts Pack OT-4 (King Pin).

<p>OT-4 KING PIN</p>  <p>Ⓢ King Pin ...4</p>	<p>OT-5 JOINT</p>  <p>Ⓢ Joint ...2</p>	<p>OT-6 SWING SHAFT</p>  <p>Ⓢ Swing Shaft...2</p>	<p>OT-16 KNUCKLE ARM</p>  <p>Ⓢ Knuckle Arm (R)...1 Ⓢ Knuckle Arm (L)...1</p>
<p>OT-18 REAR SHAFT</p>  <p>Ⓢ Rear Shaft...2</p>	<p>OT-19 DRIVE WASHER</p>  <p>Ⓢ Drive Washer...4</p>	<p>OT-28 DIFFERENTIAL GEAR</p>  <p>Ⓢ Bevel Gear A...4 Ⓢ Bevel Gear B...4 Ⓢ Bevel Shaft...2</p>	
<p>OT-31 M3 PILLOW BALL</p>  <p>Ⓢ M3 Pillow Ball (Silver)...10</p>	<p>OT-32 5.8 φ BALL</p>  <p>Ⓢ 5.8 φ Ball (Silver)...10</p>	<p>OT-33 BALL NUT (M2,6)</p>  <p>Ⓢ Ball NUT ...10</p>	<p>OT-36 M2,6 PILLOW BALL</p>  <p>Ⓢ M2,6 Pillow Ball...10</p>
<p>OT-38 SILICONE GREASE</p>  <p>Ⓢ Silicone Grease...2</p>	<p>OT-39 E RING (2,5)</p>  <p>Ⓢ E Ring (E-2,5)...10</p>	<p>OT-45 REAR HUB</p>  <p>Ⓢ Rear Hub (R)...1 Ⓢ Rear Hub (L)...1</p>	
<p>OT-66 LOW PROFILE TIRE (PIN TYPE)</p>  <p>Ⓢ Tire...2</p>	<p>OT-69 SUSPENSION ARM SET</p>  <p>Ⓢ Front Suspension Arm...2 Ⓢ Rear Suspension Arm...2</p>		<p>OT-55 FRONT HUB</p>  <p>Ⓢ Front Hub (R)...1 Ⓢ Front Hub (L)...1</p>
<p>OT-84 GEAR BOX</p>  <p>Ⓢ Rear Gear Box (R)...1 Ⓢ Front Gear Box (R)...1 Ⓢ Rear Gear Box (L)...1 Ⓢ Front Gear Box (L)...1</p>		<p>OT-73 MOTOR CLEANER</p>  <p>Ⓢ Motor Cleaner...2</p>  <p>Ⓢ Motor Plate...1</p>	
<p>OT-85 SPUR GEAR</p>  <p>Ⓢ Center Gear...1 Ⓢ Spur Gear...1</p>		<p>OT-79 MOTOR CORD</p>  <p>Ⓢ Motor Cord...2</p>	
<p>OT-86 COUNTER GEAR</p>  <p>Ⓢ Counter Gear...1</p>			

OPTIONAL PARTS LIST

OT-64 SPECIAL WING

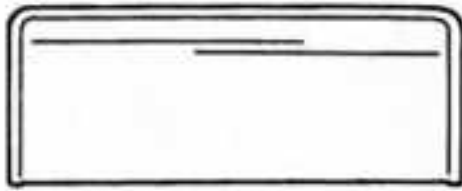

Special Wing (Silver)...1

OT-67 LOW PROFILE WHEEL (White)

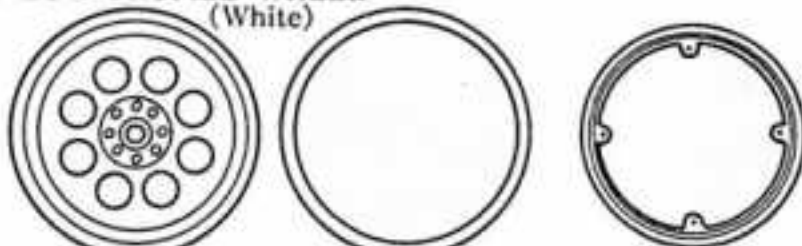

Wheel (1)...2 Wheel (2)...2 Wheel (3)...2

1863 SPONCER STICKER

Sponcer Sticker ...2

OT-47 FRONT HUB SET (Low Caster)

Front Hub (R)...1 Front Hub (L)...1

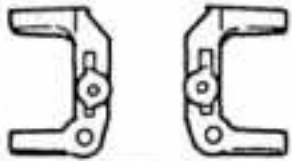

HARD PINION GEAR



W-5085(15T) W-5090(20T)
W-5086(16T) W-5091(21T)
W-5087(17T) W-5092(22T)
W-5088(18T) W-5093(23T)
W-5089(19T) W-5094(24T)
W-5095(25T)

LM-15 COOLING PLATE



Cooling Plate...1

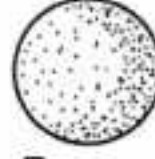

Sponge...1



M3x12
Cap Screw

1951 SHOCK OIL SET (S,M,H)



1952 DIFFERENTIAL OIL



Differential Oil...1

1953 SILICONE OIL (S)



Viscosity 100SC,200SC...1ea

1954 SILICONE OIL (M)



Viscosity 300SC,400SC...1ea

1955 SILICONE OIL (H)



Viscosity 500SC,600SC...1ea

W-5031 LOW PROFILE TIRE (Hard)



Low Profile Tire...2

UM-17 WHEEL SET (White)



Wheel (1)...2

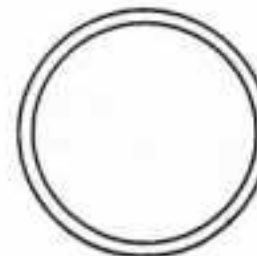

Wheel (2)...2



Wheel (3)...2

W-5032 LOW PROFILE TIRE (Soft)



Low Profile Tire ...2

W-5021 LOW PROFILE WHEEL SET (Silver Plated)



Wheel (1)...2

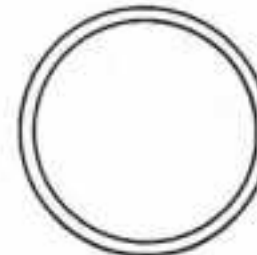

Wheel (2)...2



Wheel (3)...2

W-5003 ADJUSTABLE OIL SHOCK (S)



Adjustable Oil Shock (S)...2

W-5004 ADJUSTABLE OIL SHOCK (L)



Adjustable Oil Shock (L)...2

MEMO

.....

.....

.....

.....

.....

The Super Hobby



®

PRINTED IN JAPAN.

AFC10T