

RADIO CONTROLLED ELECTRIC POWERED SPECIAL RACING BUGGY

OFF-ROAD RACER

ULTIMA PRO

- LONG-TRAVEL WISHBONE/PARALLEL ARM FRONT AND REAR SUSPENSION.
- INDEPENDENT SUSPENSION ON ALL FOUR WHEELS WITH OIL-FILLED PRESSURE SHOCK ABSORBERS AND STABILIZER BARS.
- FOURTEEN BALL BEARING INCLUDED IN KIT.
- STRONG, LIGHT ITS ALLOY CHASSIS, PERFORATED FOR SADDLE PACK-TYPE BATTERIES.
- FINE-PITCH DRIVE GEARS FOR SMOOTH POWERFLOW STRONG ENOUGH FOR THE MOST POWERFUL MOTORS.
- LIGHT, LOW-LOSS BALL-TYPE DIFFERENTIAL.
- LOW-PROFILE TIRES WITH HIGH-GRIP SPIKE TREAD.
- MOTOR, 7.2v-1700mAh NiCd BATTERY, 2 CHANNEL RADIO. (NOT INCLUDED)

1:10 SCALE



KYOSHO
THE FINEST RADIO CONTROL MODELS

KIT NO.3117

BEFORE YOU BEGIN ASSEMBLY!

Thank you for purchasing the Kyosho's R/C "EP Off-Road Car Ultima Pro".

In order to keep your Ultima Pro in the tip top condition to enjoy the most pleasure from the R/C world, you should thoroughly read through this instruction manual and the operation instruction of the radio control units to keep the correct way of assembling, and handling.

《KIT FUTURES》

- Our new designed chassis from duralummin made for the saddle type battery, but stick type battery is also can be installed.
- For front new pin spike tires and for rear low-profile pin spike tires are included.
- For reduction gear this kit uses new gear type with module of 0.6 mm. This change made the possibility of setting the gear even finer for adjustment.
- This kit was made to use the 2 channel radio controller and electrical speed control.

CONTENTS

BEFORE YOU BEGIN ASSEMBLY	2	23 INSTALLATION OF MOTOR CORD	14
BEFORE ASSEMBLY	3	24 INSTALLATION OF MOTOR GUARD	14
LIST OF BAGGED PARTS (1)	4	25 INSTALLATION OF CENTER GUARD	14
LIST OF BAGGED PARTS (2) LAYOUT DRAWING OF PLASTIC PARTS ON RUNNERS.	5	26 INSTALLATION OF MOTOR	15
● ASSEMBLY OF CHASSIS PORTION 1 ~ 29		27 INSTALLATION OF GEAR COVER	15
1 DISASSEMBLY OF SHOCK	6	28 ASSEMBLY OF WHEEL TIRE	15
2 ASEEMBLY OF SHOCK	6	29 INSTALLATION OF TIRE	16
3 FILLING THE OIL SHOCK	6	● INSTALLATION OF RADIO UNIT • LINKAGE 30 ~ 34	
4 SCREW IN TEH BALL END	7	30 HOW TO CHECK RADIO UNIT	16
5 INSTALLATION OF COUNTER GEAR	7	31 INSTALLATION OF STEERING SERVO	16
6 INSTALLATION FINAL PINION GEAR	7	32 INSTALLATION OF AMP	17
7 ASSEMBLY OF GEARBOX	8	33 INSTALLATION OF RECEIVER	18
8 INSTALLATION OF REAR SHOCK STAY	8	34 INSTALLATION OF BATTERY	18
9 INSTALLATION OF GEARBOX	9	● CUTTING & MOUNTING OF BODY 35 ~ 38	
10 INSTALLATION OF REAR HUB	9	35 CUTTING OF BODY AND WING	19
11 INSTALLATION OF REAR SUSPENAION ARM	9	36 PAINTING	19
12 INSTALLATION OF REAR SHOCK AND STABILIZER	10	37 APPLY OF DECAL	19
13 INSTALLATION OF KNUCKLE ARM	10	38 ASSEMBLY OF WING AND MOUNTING OF BODY	20
14 INSTSALLATION OF FRONT SHOCK STAY	10		20
15 INSTALLATION OF FRONT SUSPENSION ARM	11	SETTING GUIDE (1)	21
16 INSTALLATION OF FRONT STABILIZER	11	SETTING GUIDE (2) /PARTS LIST	22
17 INSTALLATION OF FRONT BULK HEAD	11	PURCHASABLE PARTS FOR YOUR KIT	23
18 INSTSALLATION OF FRONT SHOCK	12	EXPLODED VIEW	24
19 ASSEMBLY OF SERVO SAVER	12	"	25
20 INSTALLATION OF SERVO SAVER	12		
21 INSTALLATION OF TIE ROD	13		
22 INSTALLATION OF RADIO PLATE	13		

BEFORE ASSEMBLY

○ Read the instruction carefully.

You can assemble the kit more easily if you have grasped the general idea of steps and structure beforehand by reading it through to the end.

○ Check the parts in the kits.

Check to see if all the parts are correctly bagged as they are listed in the "List of Bagged Parts" (page 4,5). Your thorough understanding of the assembly will enable you to build the kit without any difficulty.

Check the components in the kit prior to your startings of the assembly.

Any claims for replacements or refunds for the model in the process of assembly will not be accepted.

○ Learn the marks described in the instruction.

SW-CEMENT ... Place to put some locktite.

It will prevent the screws and nuts get loosen by vibration while running.

GREASE ... Point where grease should applied.

It will reduce friction and assure smooth movements.



Instruction



List of bagged parts



Steps where your particular attention is required.

○ Be well aware of the different types of screws.

1 The difference between the TP screw (short form of self-tapping screw) and the ordinary screw is ...

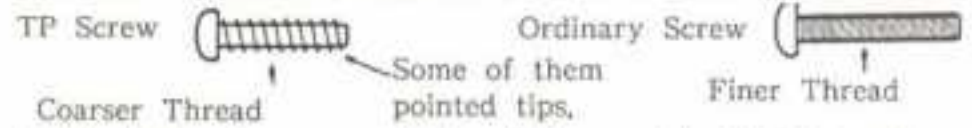

2 The kinds of screws which will be used in this instruction.

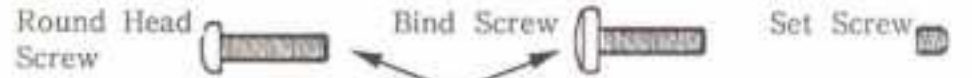

There are two kinds of thread, finer and coarser ones.



○ Pick up the correct parts and screw. Compare the shape and size of small parts, such as screws, nuts, and washers.

○ Be sure about the location and direction of parts to install.

Double-check the location and orientation of parts with the illustration before installation. When necessary, assemble the parts themselves tentatively before proceeding to the next step.

○ Do not tighten the self-tapping screw too tight.

Do not use excessive force when tightening the self-tapping screws, or you may strip the thread in the plastic. It is recommended to stop tightening it when the thread part on the screw goes into the plastic part and you feel some resistance from the tightening.

Over tighten may strip the thread in the plastic

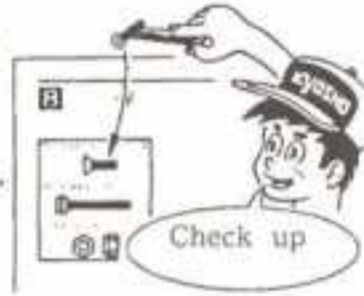
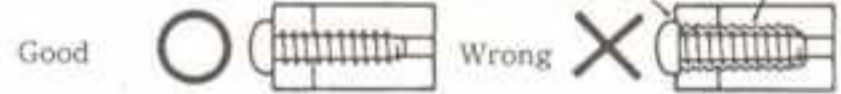

THINGS NEED BESIDES THE KIT

<2 Channel Radio System>

Two types of radio control set are on the market, the stick and the steering wheel type. Choose which ever you like.

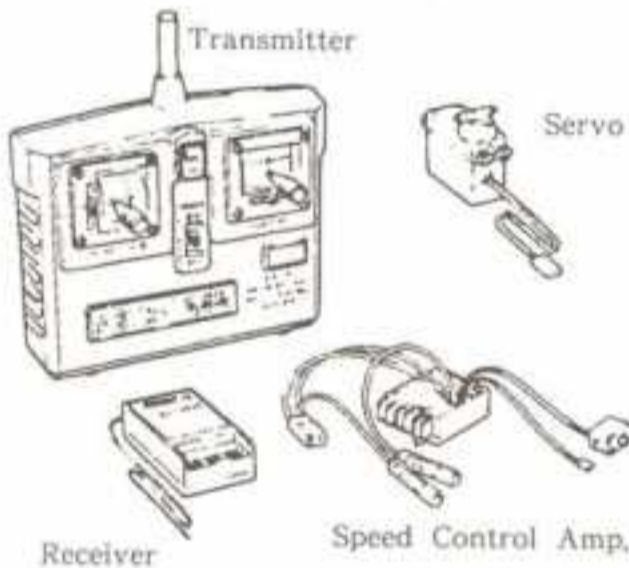

Receiver

Speed Control Amp.

AA Size Battery For Transmitter

.....8 pcs.



<NiCd Battery>

"Ultima Pro" is designed to use a rechargeable 7.2V NiCd Battery pack.

7.2V Sprint Battery and 7.2V Saddle Pack are ideal for the purpose.



No.2331 7.2V-1200 SCR Battery (Saddle Pack)

No.2310 7.2V-1200 Sprint Battery

<Motor>

The Ultima Pro not come with a motor, A Le Mans series type motor is recommended for top performance.

No.1986 Le Mans Speed 240T No.1925 Le Mans 360Gold
No.1926 Le Mans H-240S No.W1011 SPA 240WS



<Charger for NiCd Battery>

The Kyosho's NiCd battery is of high performance. If it is charged correctly, it will operate for a considerable period of time.

Use one of the Chargers listed below which suits your need.

Model	Name	Time	Rate %	Features
No.2326	7.2V Power Charger	15 (min.)	70	For bigginer Built-in timer
No.1849	Multi Charger II	20 (min.)	100	Timer, Ammeter built in
No.1845	Lambda Quick Charger	20 (min.)	100	Trickle charging Automatic cut-off at peak of charge

<Tools Required> A Hex Key, Grease and SW-cement are in the kit.

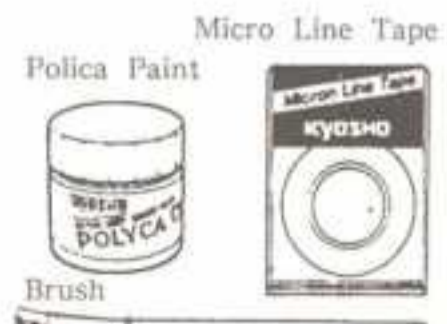
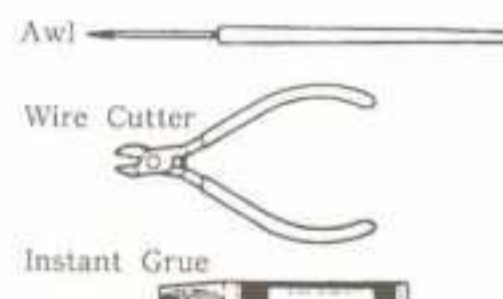
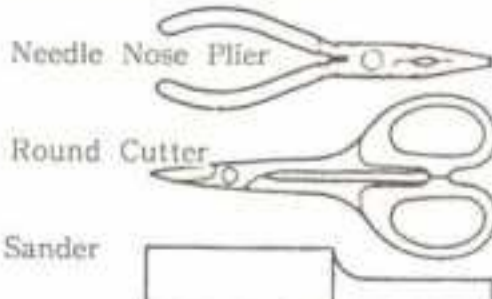
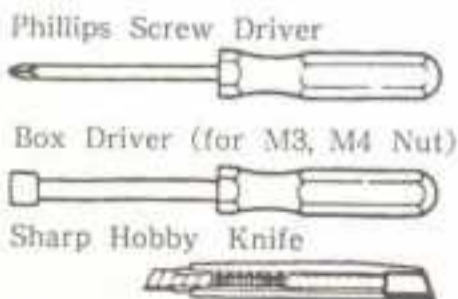

LIST OF BAGGED PARTS (1) The key numbers with ★ indicated plastic parts on a runner. See page 6 for the layout drawing.

[Do not throw away a bag header]

- The symbol in the brackets after a name of parts in this instruction is the header number in which the part is contained.
- The header is the only thing to rely upon when looking for a part. Do not discard it until you finish the assembly.



Bag	Key #	Parts Name	Q'ty	Step	
BLISTER (A)	1	Front Shock Stay	1	12	
	2	Rear Shock Stay	1	8	
	3	4 φ x8 Bearing	6	28 29	
	4	5 φ x10 Bearing	6	5 7 10	
	5	Center Gear Collar	1	25	
	6	Motor Guard	1	21	
	7	Motor Plate	1	5	
BLISTER (B)	⑧ 8	8 φ x14 Bearing	2	⑧	
	⑧ 9	Body of differential	1		
	⑧ 10	Differential Shaft (A)	1		
	⑧ 11	Differential Shaft (B)	1		
	⑧ 12	Pressure Plate	2		
	⑧ 13	8 φ x10 Collar	1		
	⑧ 14	Torque Keeper	1		
	⑧ 15	Tapered Washer	4		
	⑧ 16	Differential Ball	10		
	⑧ 17	Thrust Ball	8		
	⑧ 18	Thrust Washer	2	⑧	
	● 19	Front Shock Shaft	2		
	● 20	Rear Shock Shaft	2		
	● 21	Front Shock Case	2		
	● 22	Rear Shock Case	2		
	● 23	Front Shock Spring	2		
	● 24	Rear Shock Spring	2		
	● 25	Spring Holder	4		
	● 26	Shock Cap	4		
	● 27	Spring Stopper	4		
	● 28	Shock End	4	⑧	
	● 29	E Ring (E2.5)	4		
	30	Final Pinion	1		3
	31	Center Gear	1		28
	32	Counter Gear	1		5
	33	Swing Shaft	2		11
	34	Wing Post	2		22
	35	Drive Washer	2		20
	36	Rear Wheel Shaft	2		10
37	Front Suspension Arm	2	15		
38	Rear Suspension Arm	2	10		
UTP-2	39	Radio Plate	1	22	
	40	Gearbox (L)	1	7	
	41	Gearbox (R)	1	5	
	★ 42	Stabilizer Link (L)	2	12	
	★ 43	Stabilizer Link (S)	2	10	
	★ 44	Stabilizer Stopper	2	3	
	45	Motor Cord	1	28	
	46	Wing Stay	1	11	
	47	Gear Cover Seal	1	27	
	48	Double Sided Tape	1	17 18 19	
	49	Strap (S)	2	17 18	
	50	Ni-Cd Strap	2	10	
	51	Antenna Pipe	1	88	

Bag	Key #	Parts Name	Q'ty	Step
UTP-2	52	Shock Oil (Green)	1	8
	53	Screw Locking Compound	1	
	54	Silicon Grease	1	
	55	Condensor	1	23
UTP-3	56	Rear Wheel	2	28
	57	Front Wheel	2	28
UTP-4	58	Pinion Gear (20T)	1	28
	59	Center Gear Shaft	1	29
	60	Counter Gear Shaft	1	5
	61	2 φ x11 Pin	2	5
	62	Front Wheel Shaft	2	16
	63	Servo Saver Shaft	2	20
	64	Wing Stopper	2	10
	65	Radio Plate Post	2	22
	66	3 φ x32 Adjust Rod	4	2
	67	3 φ x50 Adjust Rod	2	2
	68	5.8 φ Ball (Black)	6	2
	69	O Ring (P3 • Black)	1	28
	70	Motor Guard Collar	2	21
	★ 71	Shock Piston	4	2
	72	Shock Collar (White)	4	2
	73	Shock Collar (Black)	4	2
	74	Pressure Top	4	3
	75	O Ring (P3 • Red)	8	2
	76	C Ring	8	2
	29	E Ring (E2.5)	8	2
	M3x18 Cap Screw	2	5 10	
UTP-5	77	Front Stabilizer	1	10
	78	Rear Stabilizer	1	13
	79	Rear Suspension Shaft (B)	2	10
	80	Stabilizer Ball	2	10
	81	Adjust Ball	4	12 13
	82	Sponge Cap	1	7
	83	Motor Guard Plate	1	21
	84	Servo Saver Spring	1	19
	85	Front Bulk Head	1	10
	86	Rear Axle Stopper	1	10
UTP-6	87	Rear Bulk Head	1	3
	88	Gear Cover	1	27
	89	Bumper	1	10
	★ 90	Front Hub	2	13
	★ 91	Rear Hub	2	10
	★ 92	Knuckle Arm (L)	1	10
	★ 93	Knuckle (R)	1	13
	★ 94	Servo Saver (A)	1	10
	★ 95	Servo Saver (B)	1	10
	★ 96	Servo Saver (C)	1	10
	★ 97	Servo Saver (D)	1	10
	★ 98	Servo Saver Collar	2	20
	★ 99	Gearbox Hatch	1	9
	★ 100	M3 Plastic Nut	6	12 13

LIST OF BAGGED PARTS (2)

Bag	Key #	Parts Name	Q'ty	Step
UTP-6 PLASTIC PAR	★101	Servo Stay	4	20 Spare x 2
	★102	Shock Collar	4	17 18
	★103	Antenna Post	1	22
	★104	Battery Stopper	2	34
	★105	Stopper Post	4	22
	★106	Stopper Washer (Thinner one)	2	
	★107	Stopper Washer (Thicker one)	2	22
UTP-7	★133	Body Hook	1	22
	108	Ball End (L)	12	23
	109	Ball End (S)	1	21
	110	Front Sus. Shaft (A) (Silver)	2	15
	111	Rear Sus. Shaft (A) (Black)	2	16
	112	Ball Nut	1	19
	113	5,8 φ Ball (Silver)	10	24 25
	114	4,8 φ Ball	2	10
	115	Front Suspension Shaft (B)	2	15
	116	King Pin	2	18
	117	Steering Rod	1	21
118	Center Rod	1	10	
119	Motor Guard Joint	1	23	
	120	Body	1	15
	121	Wing	1	15
	122	Front Tire	2	25
	123	Rear Tire	2	28
	124	Main Frame	1	9
	125	Decal	1	17
UTP-1 SCREW, NUT, WASHER, OTHERS		Instruction	1	
	29	E Ring (E2,5)	10	10 15 Spare x 2
	126	E Ring (E3) (Black)	3	18 Spare x 1
	127	E Ring (E4)	2	7 "
	128	Hook Pin	2	22 "
	129	Body Pin	7	12 13 page 20
	130	Hex Key (1,5mm)	1	15 20 page 22
	131	Hex Key (2mm)	1	6 7
	132	Hex Key (2,5mm)	1	13 14
		Bind Screw M2,6x6	8	
		" M3x6	11	
		" M3x18	2	
		" M3x35	1	
		" M3x45	2	
		Round Head Screw M2x10	2	
		" M3x33	1	
		Flat Head Screw M2,6x12	6	
		" M3x6	4	
		" M3x15	12	
		" M4x8	8	
		" M4x12	4	
		Truss Screw M4x8	4	
		TP Bind Screw M3x8	11	
		TP Round Head Screw M3x18	1	
		Nut M2,6 (3 Kinds)	10	
		Nut M3	8	
		Nylon Nut M4	4	
		Washer M3	2	
	Washer M4	2		
	Washer φ 8x12	2		
	Set Screw M3x3	5		
	Set Screw M4x4	1		

LAYOUT DRAWING OF PLASTIC PARTS ON RUNNERS

(When cutting off parts from a runner...) *Pay particular attention when detaching the position.

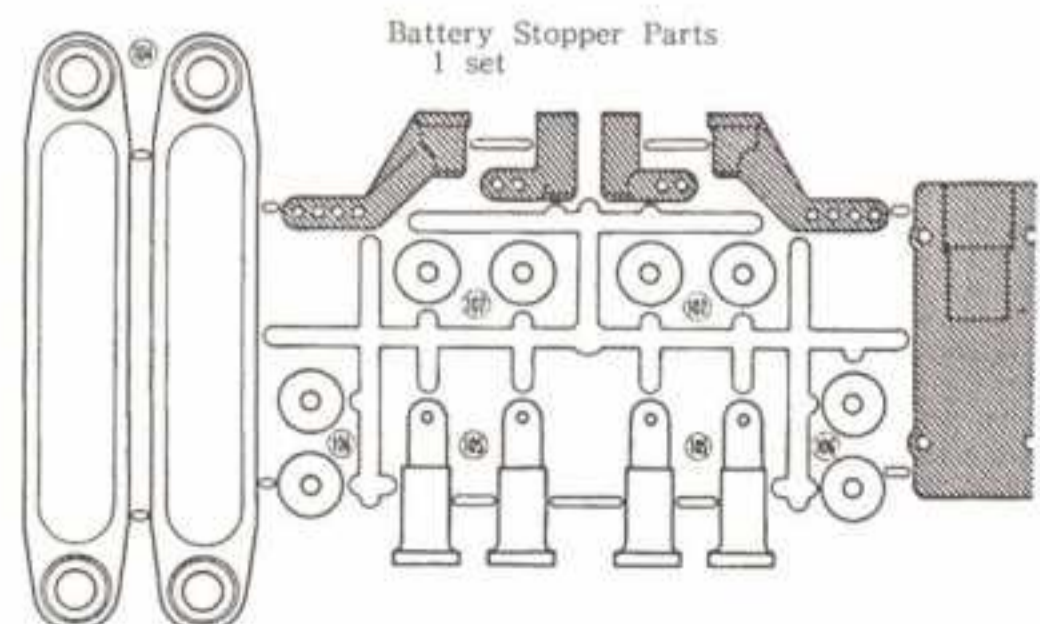
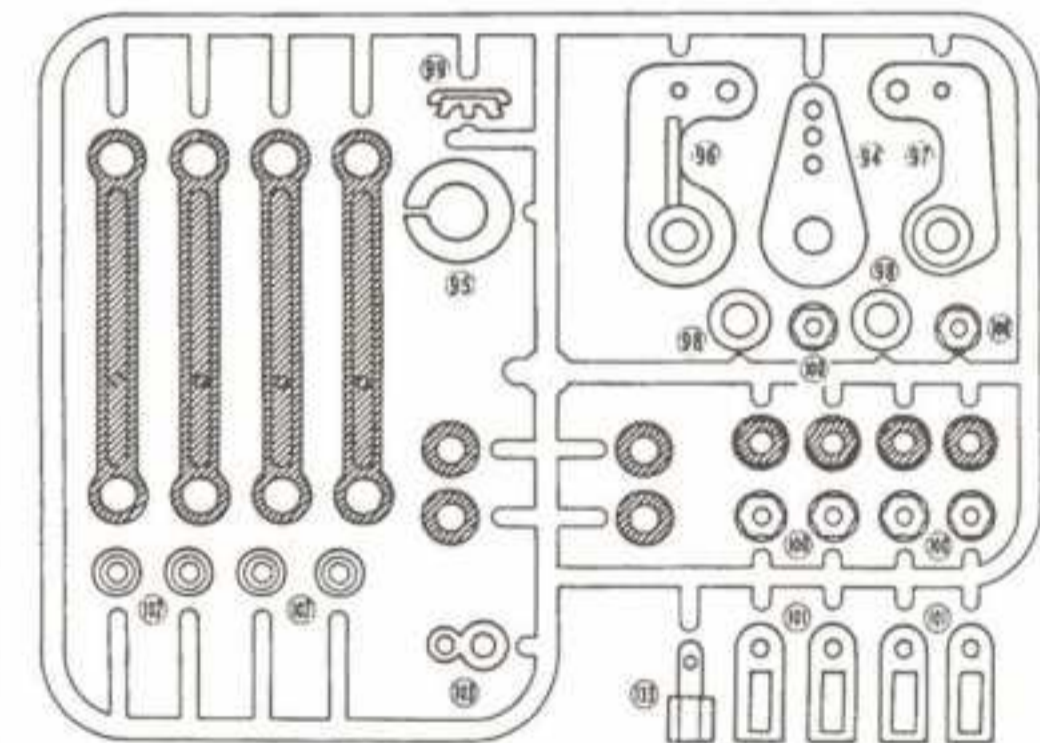
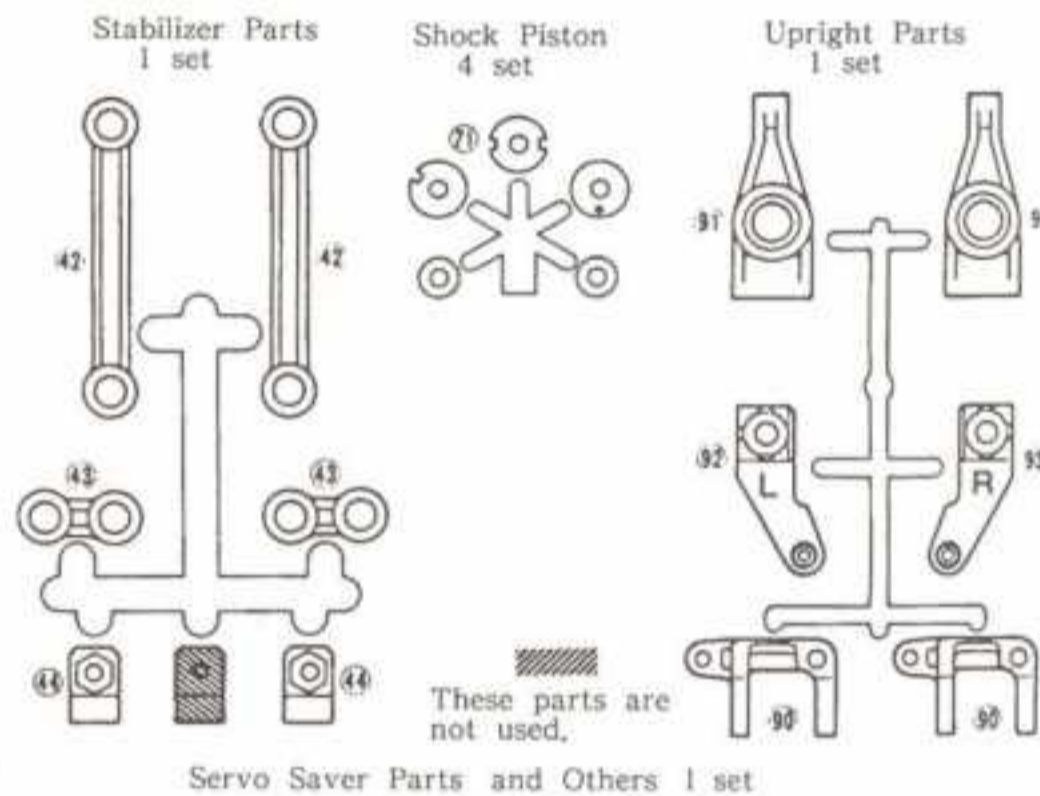
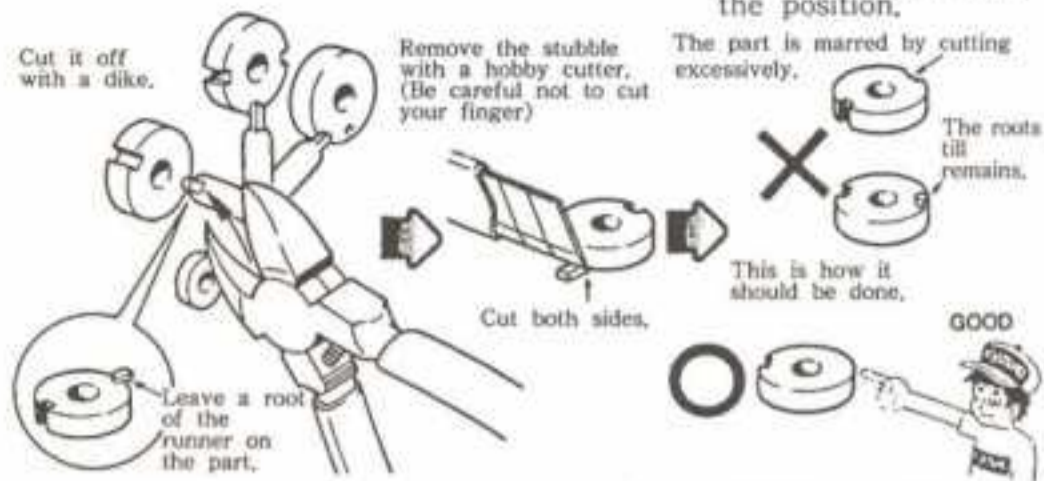

1 DISASSEMBLY OF SHOCK

Shocks are assembled temporarily, and must be disassembled to add parts and oil.

Pressure Shock (S)



Pressure Shock (L)



Stage 1

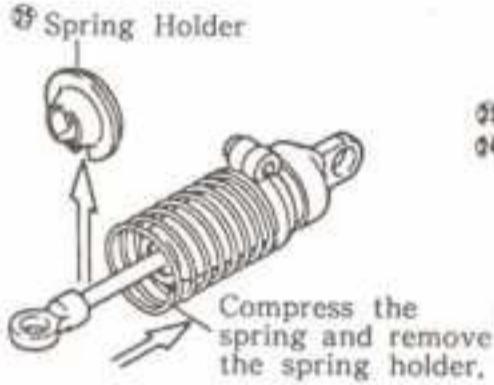

Stage 2



Stage 3

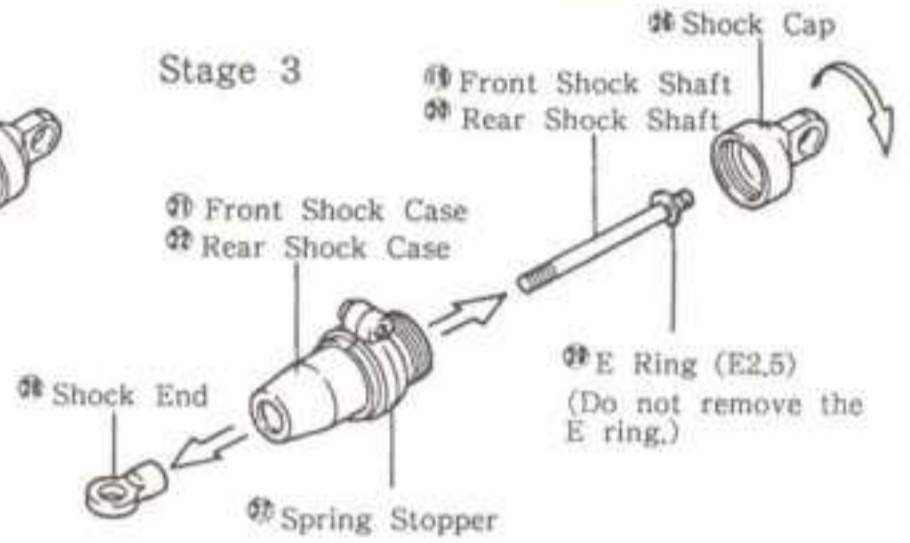

2 ASSEMBLY OF SHOCK

At each assembly stage, a drawing shows screws and other fasteners used in the actual size. Identify those required in each stage.

Shock parts included in (UTP-4)

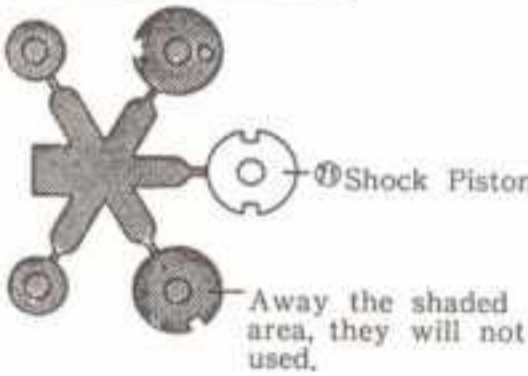
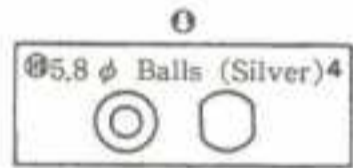

Stage 1

Fit into the groove.



Stage 2

O Ring (P3 • Red)

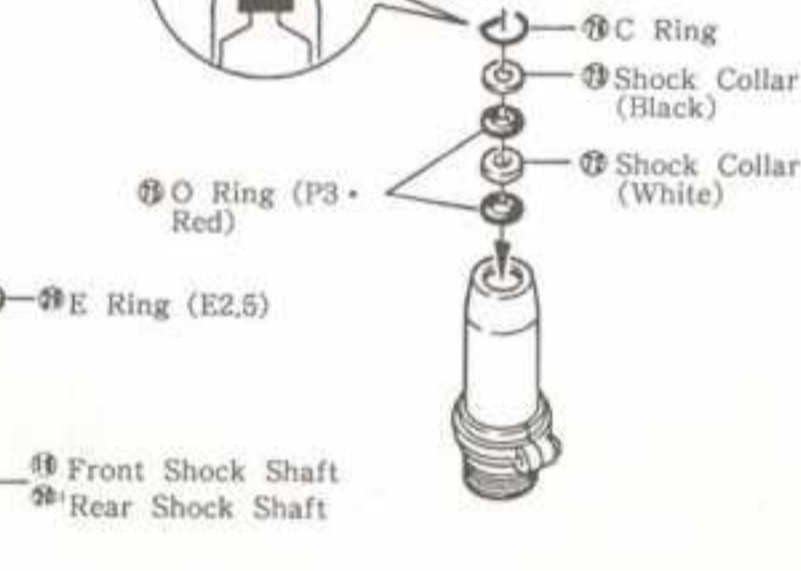

Stage 3

5.8 φ Ball (Silver) (UTP-7)



3 FILLING OF SHOCK

Stage 1 Pull down the piston to the bottom and pour oil slowly. Then move the piston up and down gently to get rid of air bubbles.

Shock Oil (Green) (UTP-2)

Full the cylinder to slightly above brim.

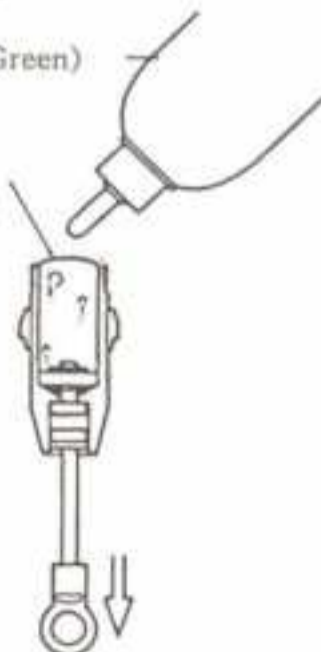

Stage 2

Keep the piston in the lowest position and tight 26 gradually, then excessive oil will run over.

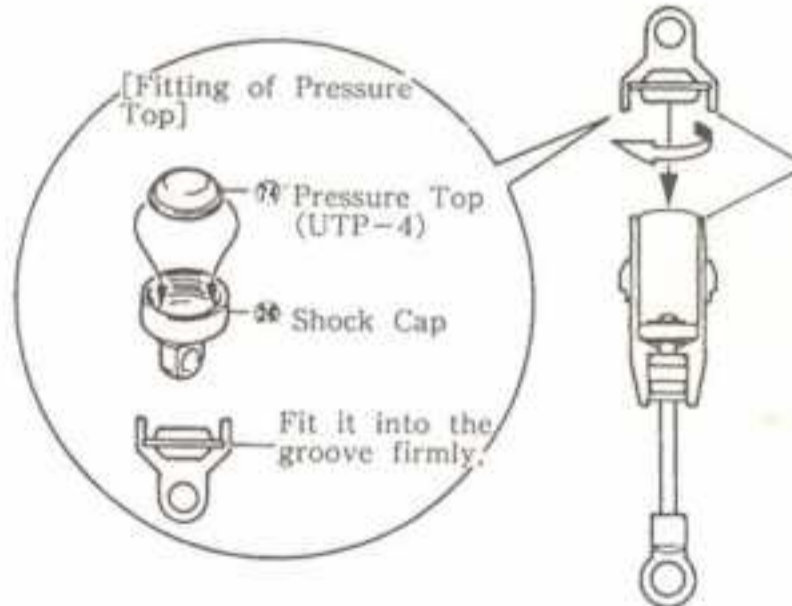

Stage 3

Confirm that it will work smoothly by moving the piston up and down.

In the end, tighten it firmly so that the oil will not leak out.

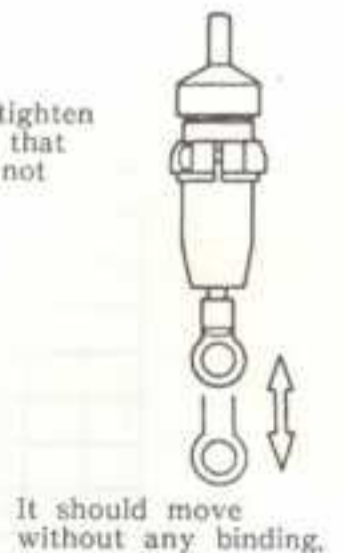

4 SCREW IN BALL END

Screw in each ball ends matching to the actual size drawings.

Assemble with caution making sure that there is not mistake in the color of the 5.8 φ ball and the direction the rods should be facing.

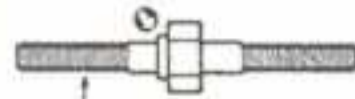

Side with the collar is a reverse thread. Screw in the ball end anti-clockwise.

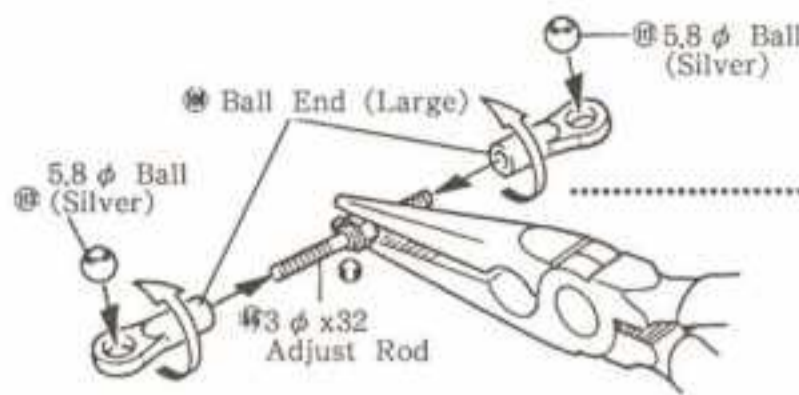

[Actual Size Drawing]

• Front Upper Rod Used in 14.

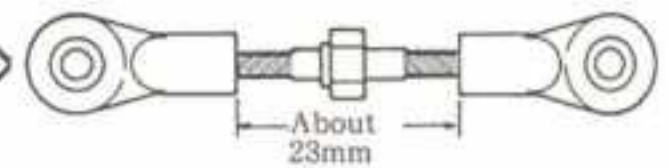

Included in [UTP-7]

• Ball Ends (L).....12

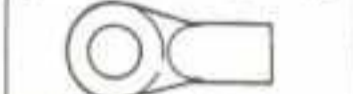

• 5.8 φ Balls (Silver).....6



Included in [UTP-4]

• 3 φ x 50 Adjust Rods.....2



• 3 φ x 32 Adjust Rods.....4

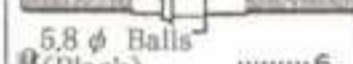

• 5.8 φ Balls (Black).....6

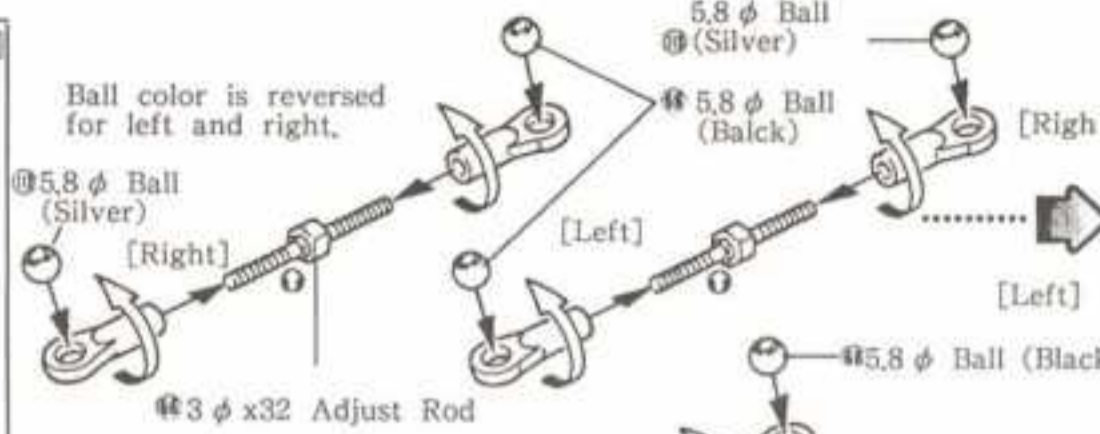
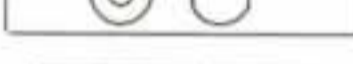

• Rear Upper rod Use in 8.

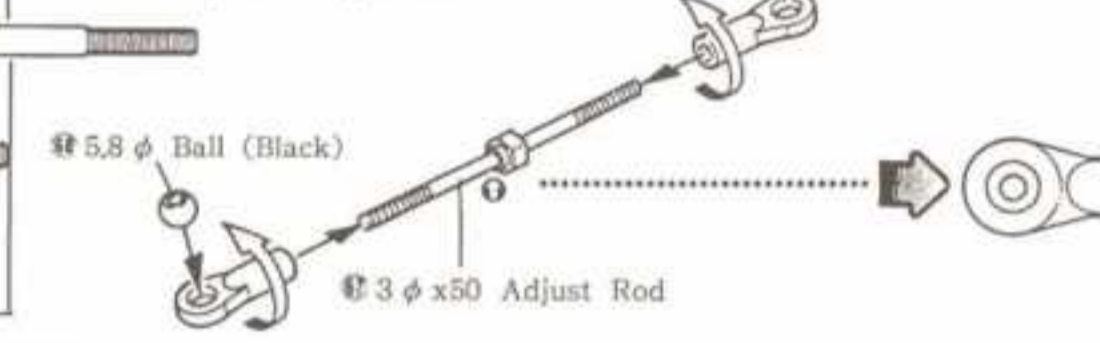
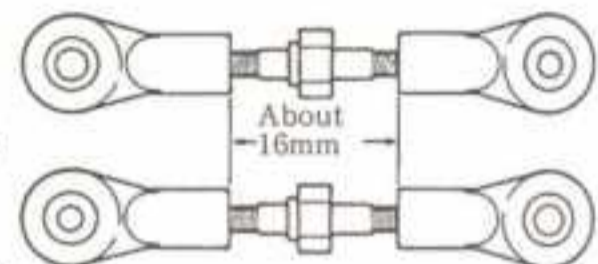

• Tie Rod Used in 21.

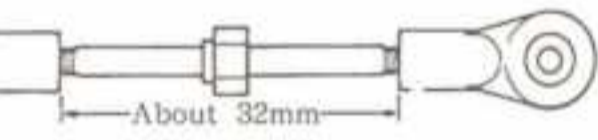

5 INSTALLATION OF COUNTER GEAR

• 5 φ x 10 Bearing 1



• 2 φ x 11 Pin..... 1

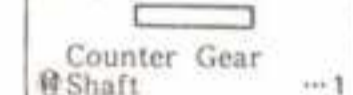

• Counter Gear Shaft..... 1

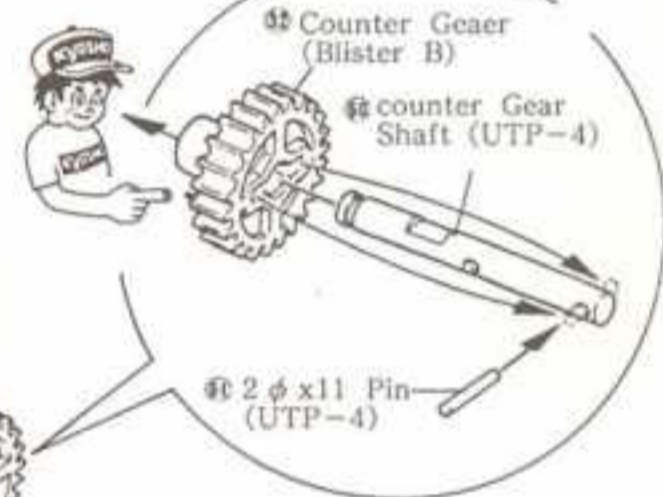
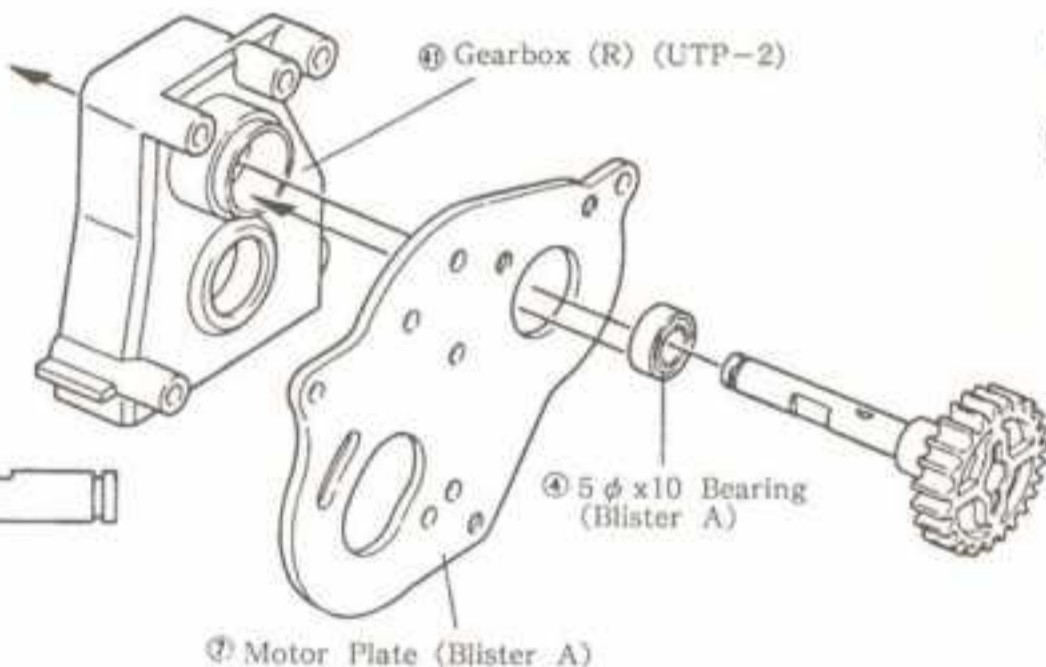

6 INSTALLATION OF FINAL PINION GEAR

• Hex Key (2mm) (UTP-1)

• M4x4 Set Screw

• M4x4 Set Screw..... 1

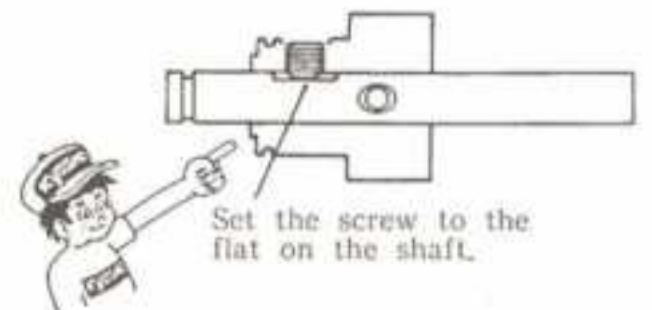
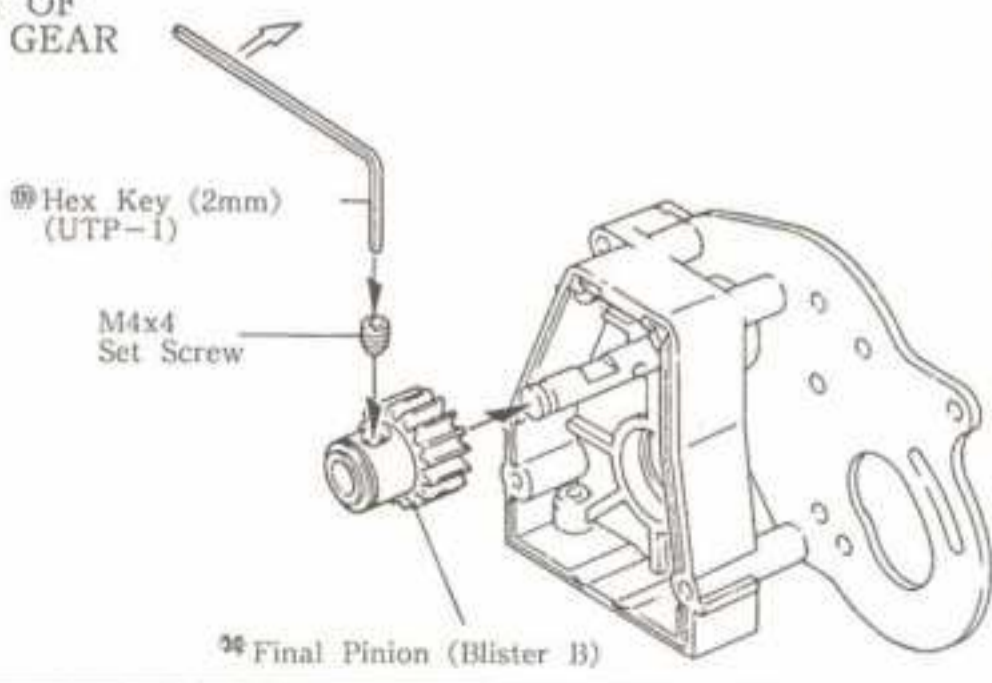

• Final Pinion (Blister B)

7 ASSEMBLY OF GEARBOX

Stage 1

Ball differential is already assembled and is included in [Blister B] but before assembling it into the gear box, check ① and ②.

① DIFFERENTIAL ITSELF SHOULD NOT TURN FREELY

When the differential itself is turned with your hand with both end of the shaft is stabilized with a minus screw driver, does it turn freely?

If it is turning freely, make adjustment as shown in the right diagrams.

- M3x18 TP Screw.....1
- M3x33 Screw.....1
- ④ 5 φ x10 Bearing.....1
- ⊗ E Ring (E4).....1

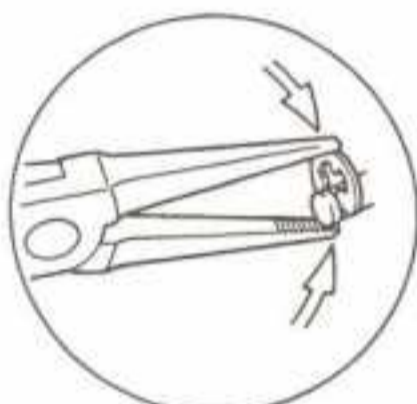
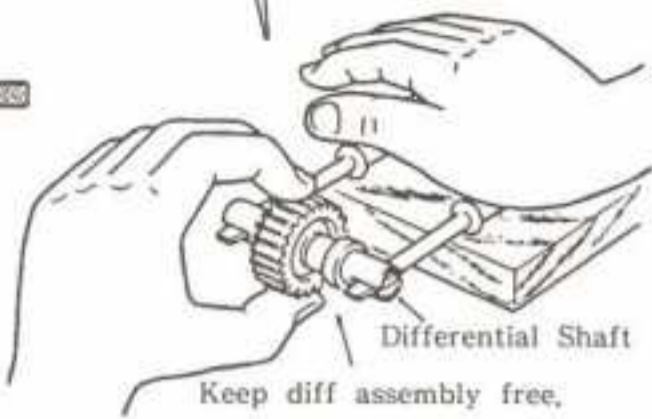

Fit an E-ring a pair of pliers.

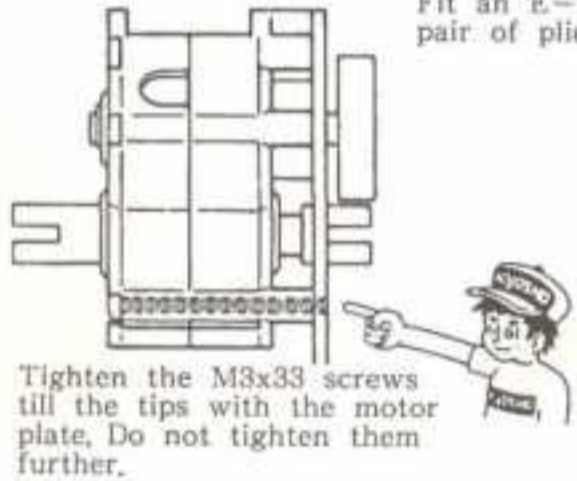

Tighten the M3x33 screws till the tips with the motor plate. Do not tighten them further.

The point of adjustment is how tight the cap screw is tightened. Adjust and re-adjust (1) and (2) are OK.



Stabilize with hex key or ⊖ screw driver.

*If the screw is over tightened or use with the differential turning freely, it will result to damaging the ball and plates.

After the adjustment has been effective... ⊗ Sponge Cap [UTP-5]



Push in.

② DIFFERENTIAL MUST BE EFFECTIVE

By holding the differential itself and by turning the differential shaft, does the opposite side shaft lightly turn in the opposite direction? (This is called the differential effectiveness)

The more you tighten the cap screw, the differential effect is lost.



Stage 2

Apply grease all around the gear teeth.

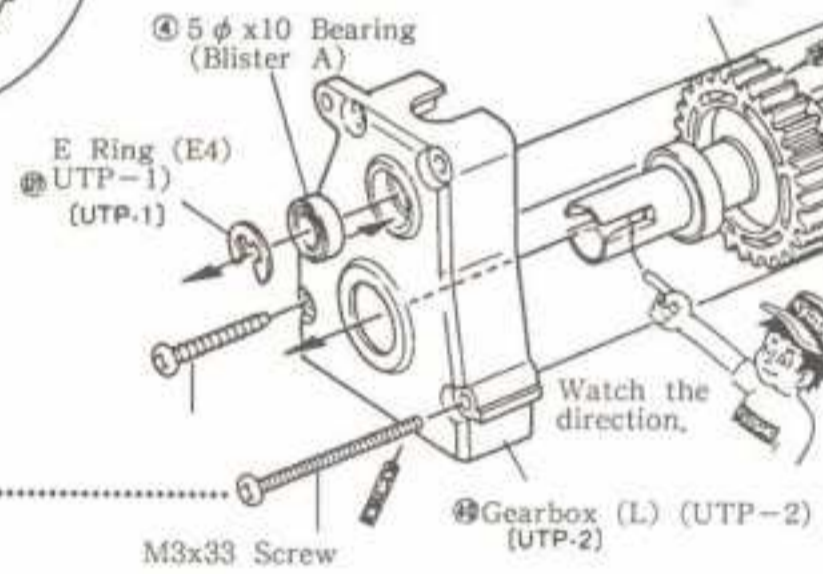

When having assembled it as shown in the drawing at right, and if you find too much end play...

See page 22. (When inserting shim for ball differential adjustment...)

8 INSTALLATION OF REAR SHOCK STAY

Stage 1

- M2,6x6 BinD Screws...2
- M3x18 Cap Screws...2
- M2,6x12 Flat Head Screws...2
- M3x8 TP Bind Screws...4
- M3 Nuts...2
- M2,6 Nuts...6

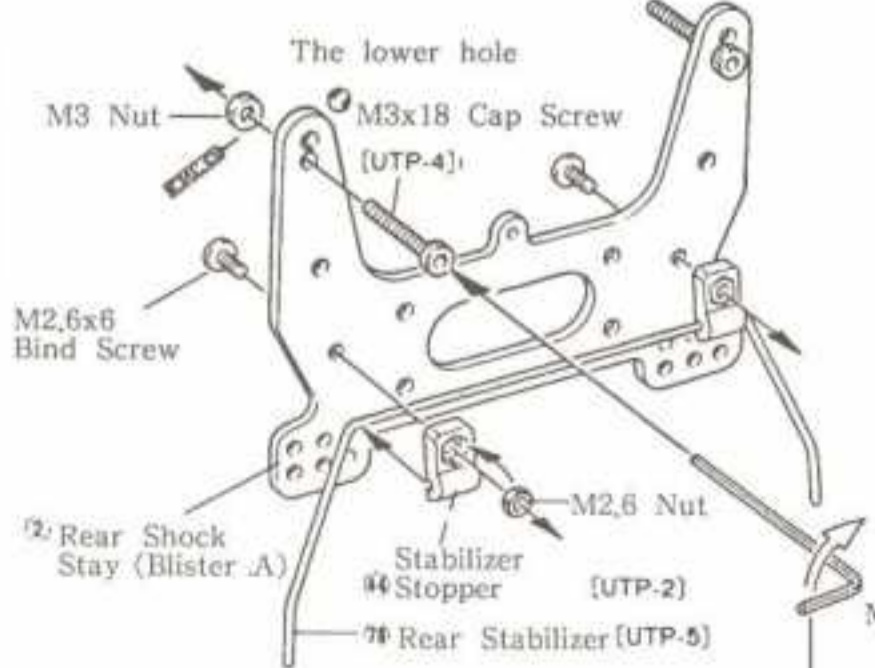

Stage 2

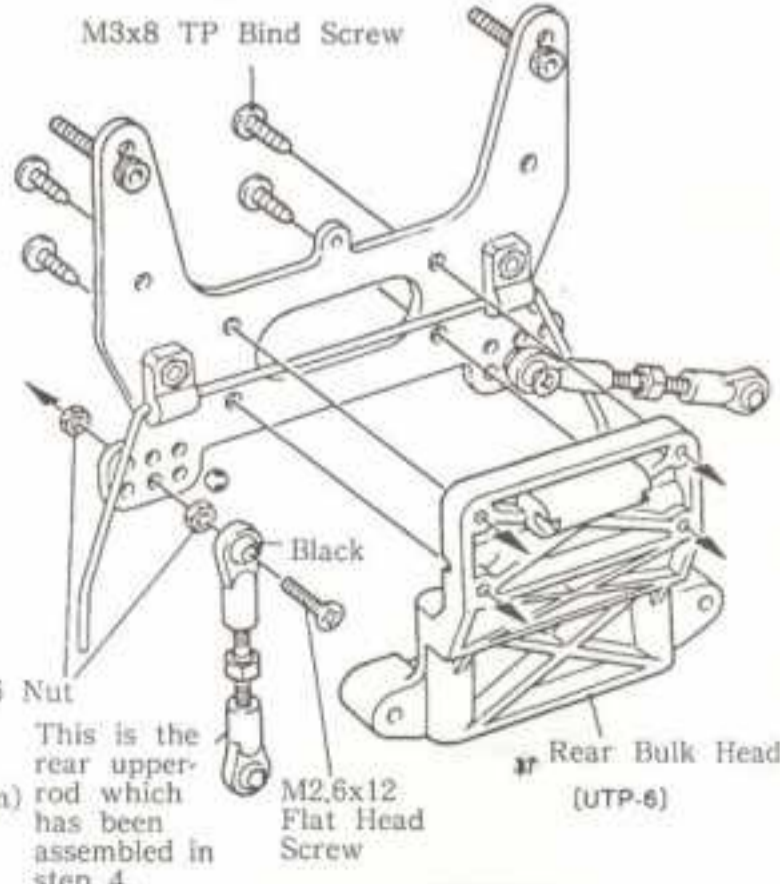

This is the rear upper rod which has been assembled in step 4.

9 INSTALLATION OF GEARBOX

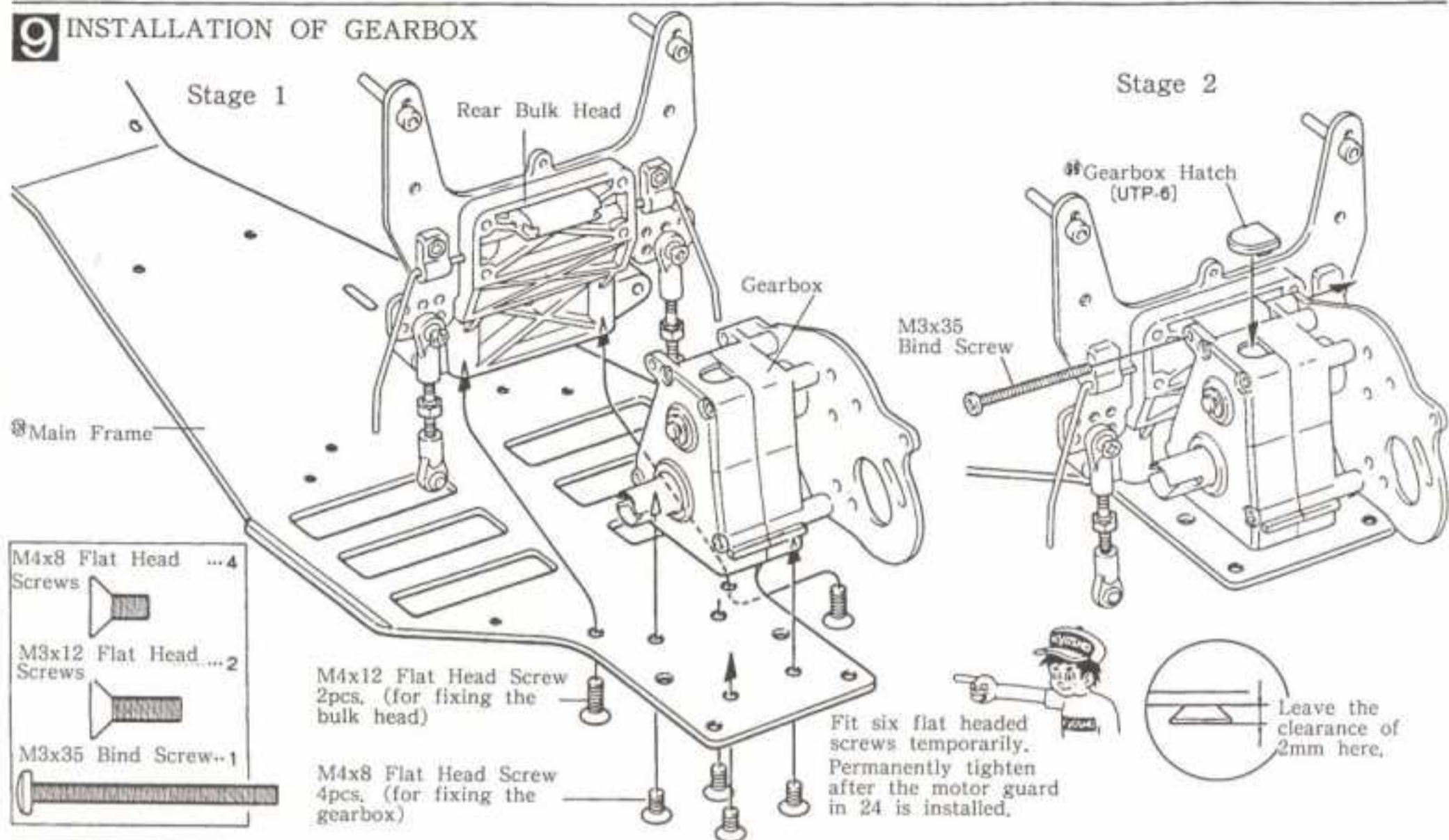

10 INSTALLATION OF REAR HUB

Stage 1

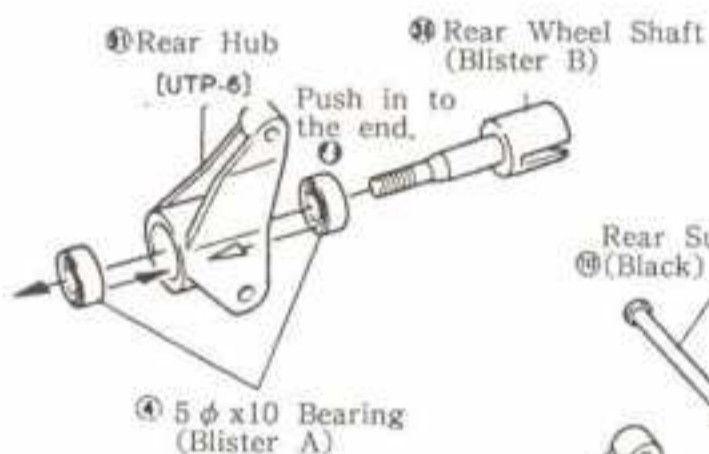
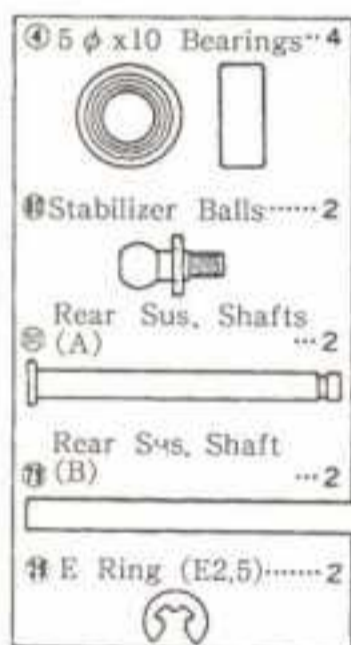

Stage 2

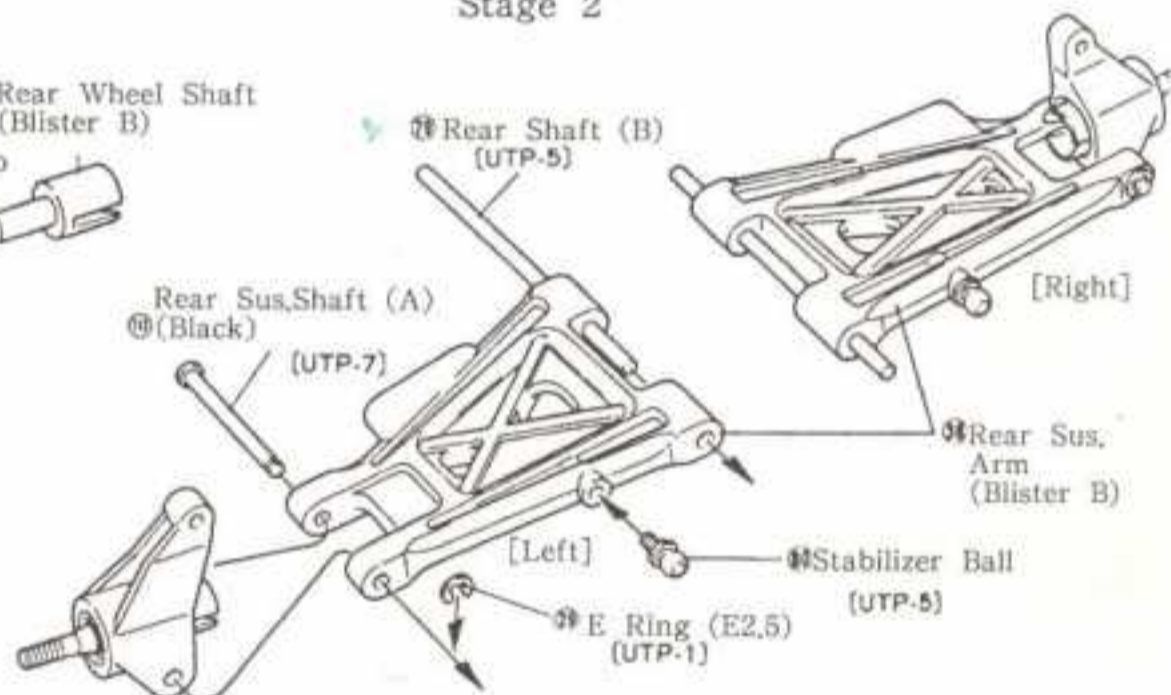

11 INSTALLATION OF REAR SUSPENSION ARM

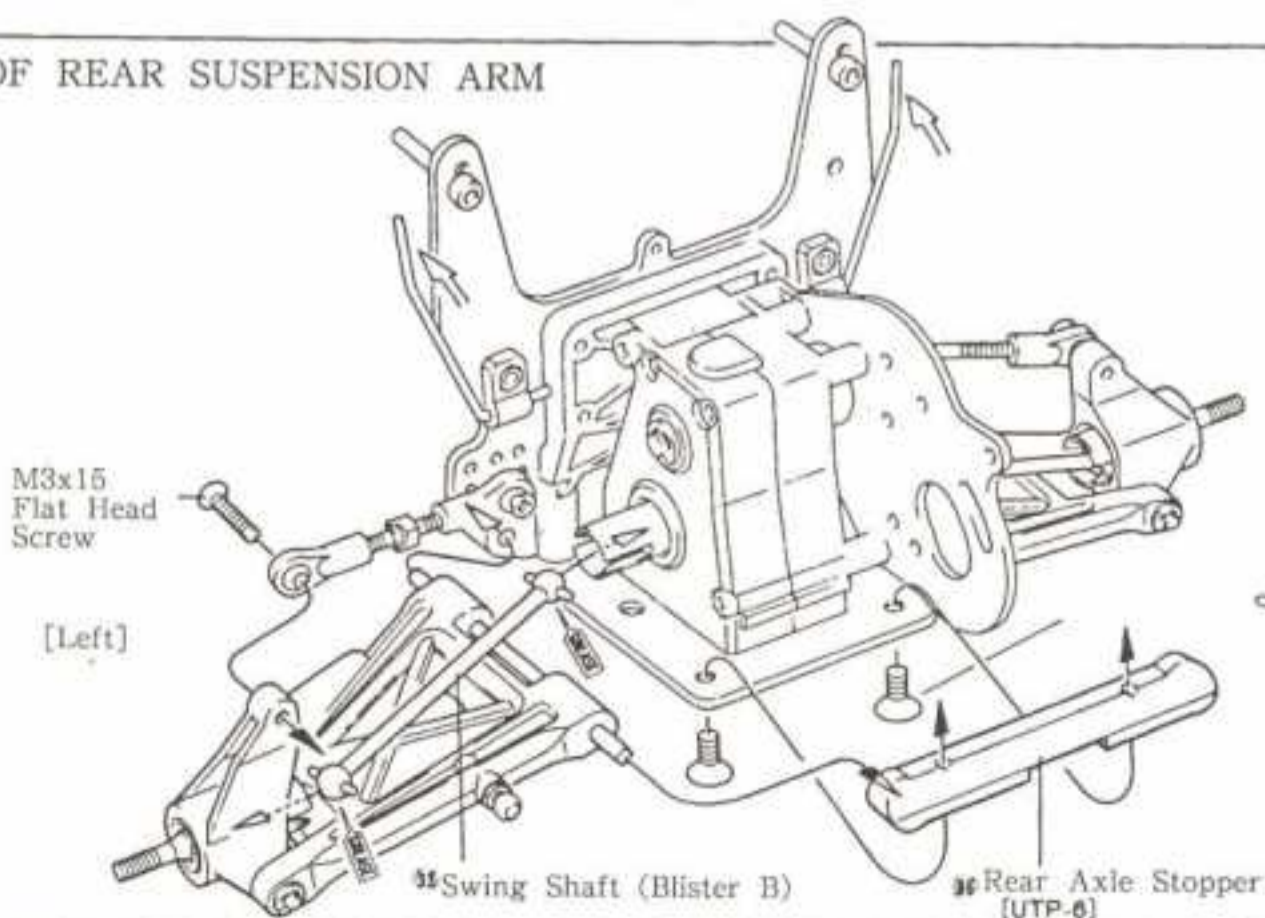
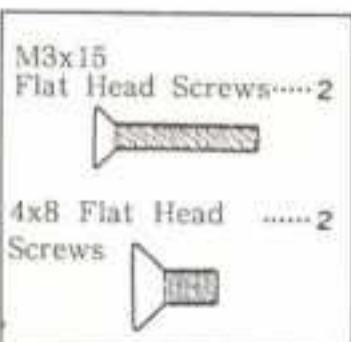

Have these 2 flat screws temporarily tightened in the same way as 9. Permanently tighten after the motor guard in 24 is installed.

12 INSTALLATION OF REAR SHOCK AND REAR STABILIZER

- M3x3 Set Screws.....2
- M3x15 Flat Head Screws.....2
- M3 Plastic Nuts.....2
- Shock Collar.....2

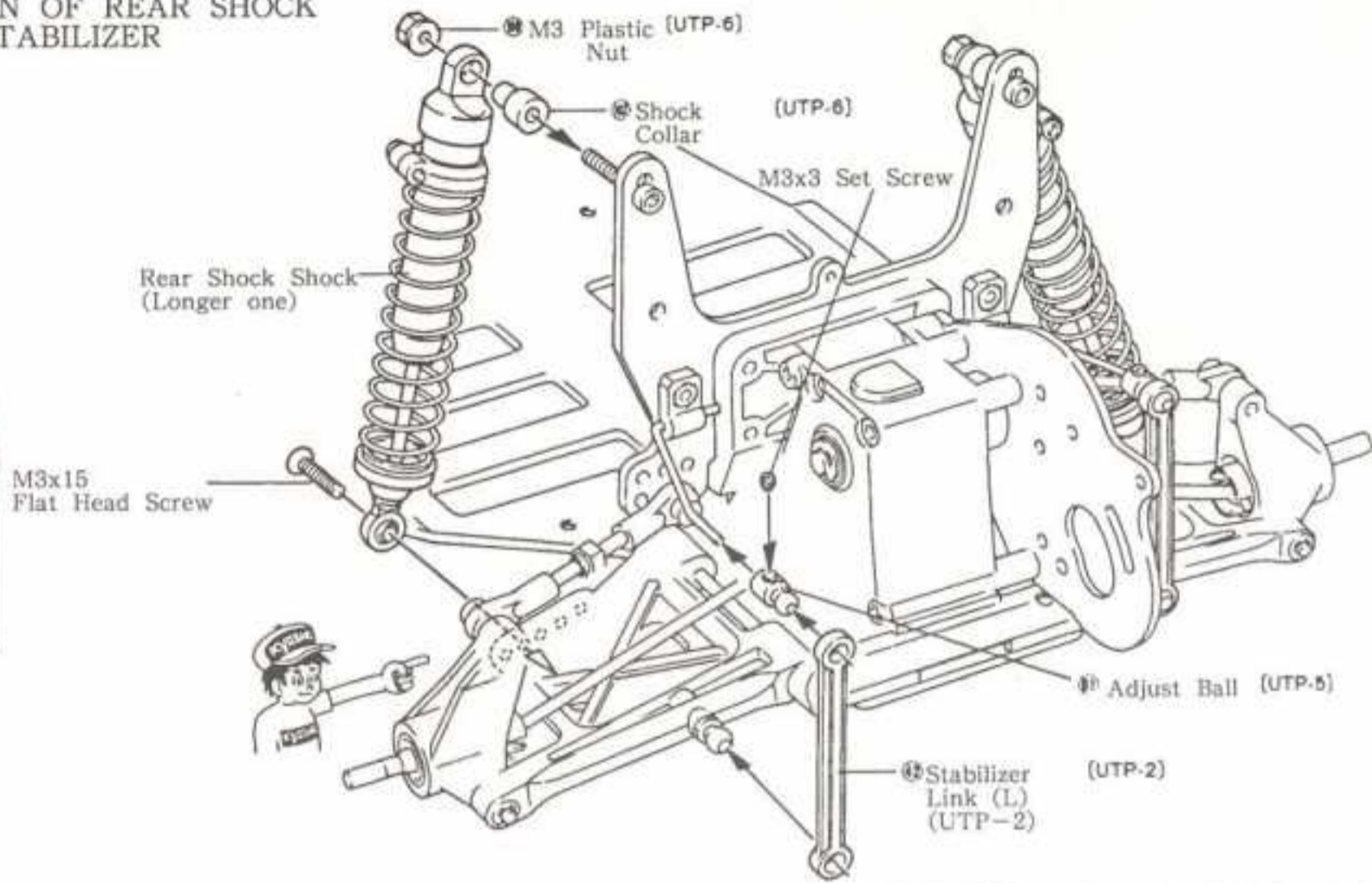

13 INSTALLATION OF KNUCKLE ARM

- King Pin.....2
- Front Hub.....2
- E Ring (E3).....2

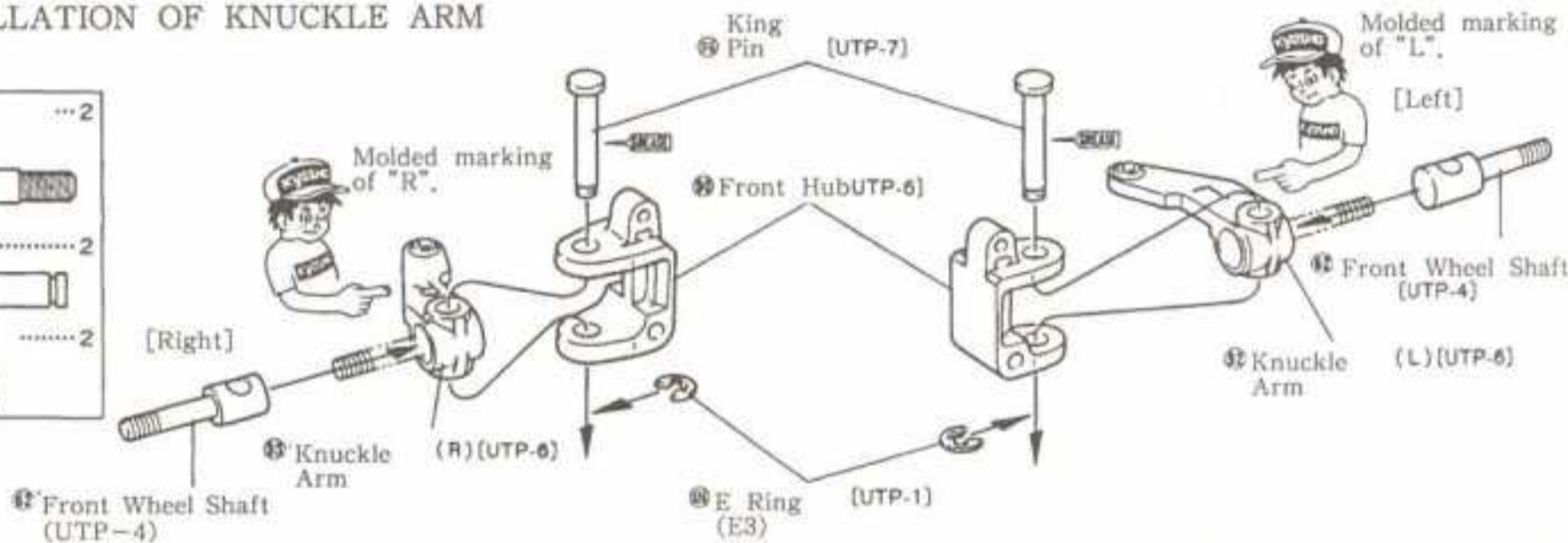

14 INSTALLATION OF FRONT SHOCK STAY

M3x18 Cap Screw (Small bag of UM-4)

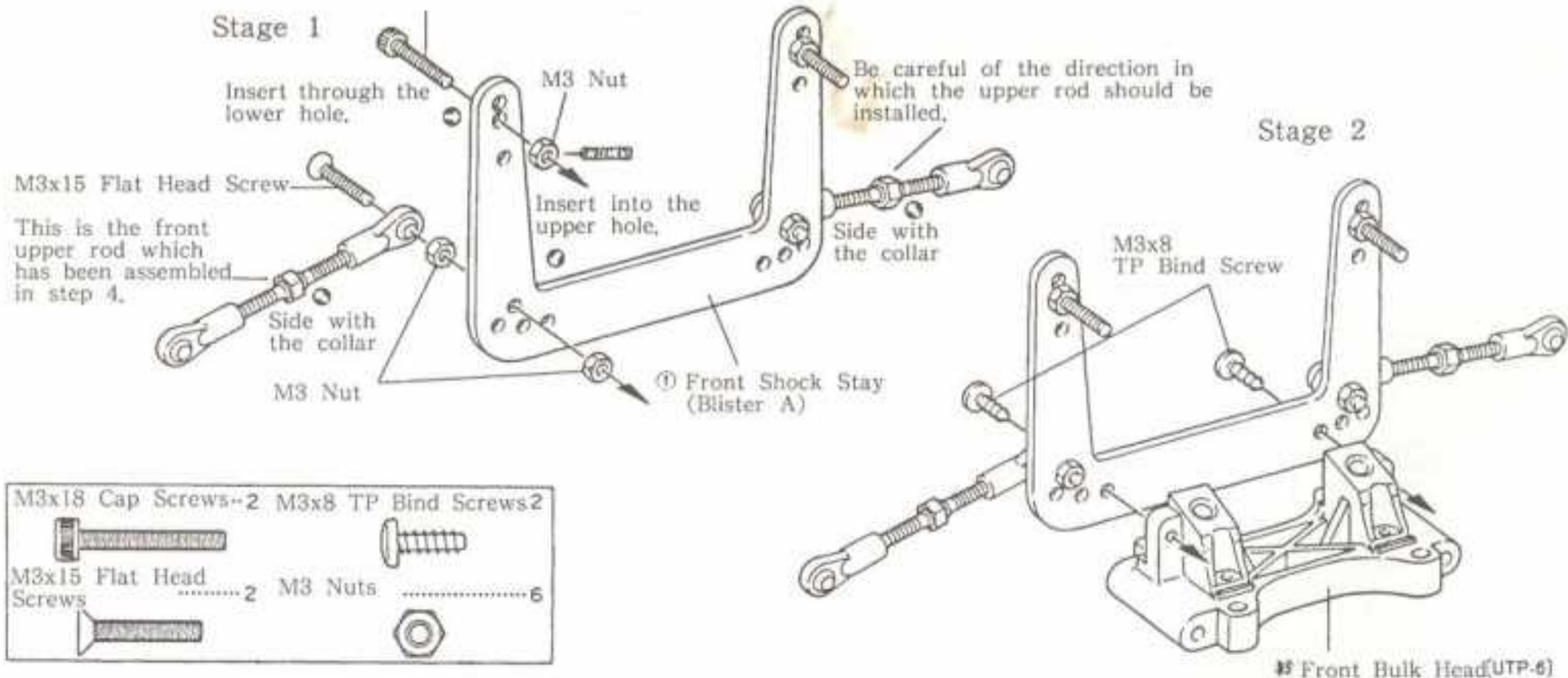

- M3x18 Cap Screws.....2
- M3x15 Flat Head Screws.....2
- M3x8 TP Bind Screws.....2
- M3 Nuts.....6

15 INSTALLATION OF FRONT SUSPENSION ARM

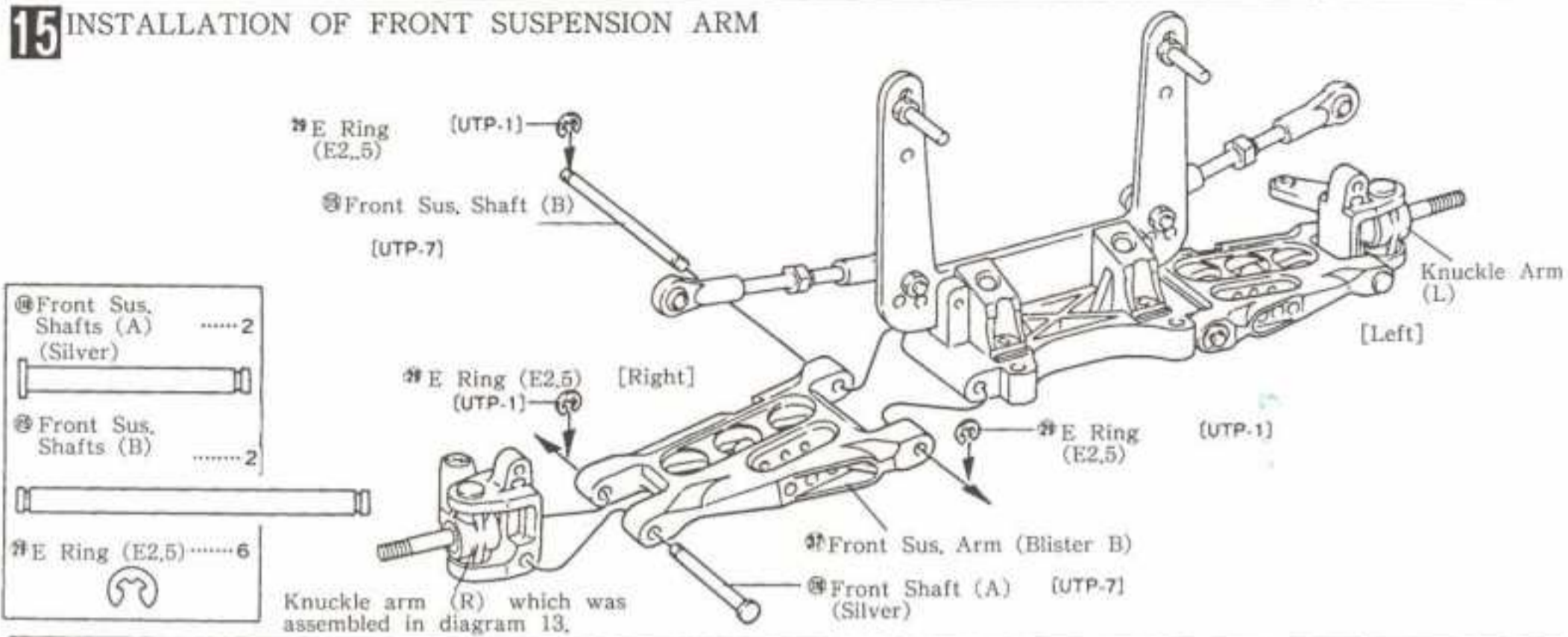

16 INSTALLATION OF FRONT STABILIZER

Stage 1

Assemble two of these for right and left.

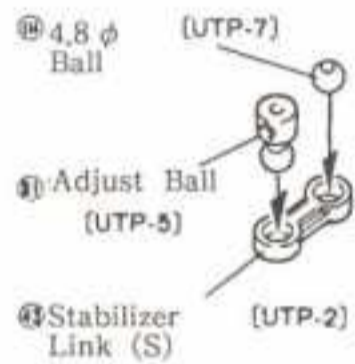

Stage 2

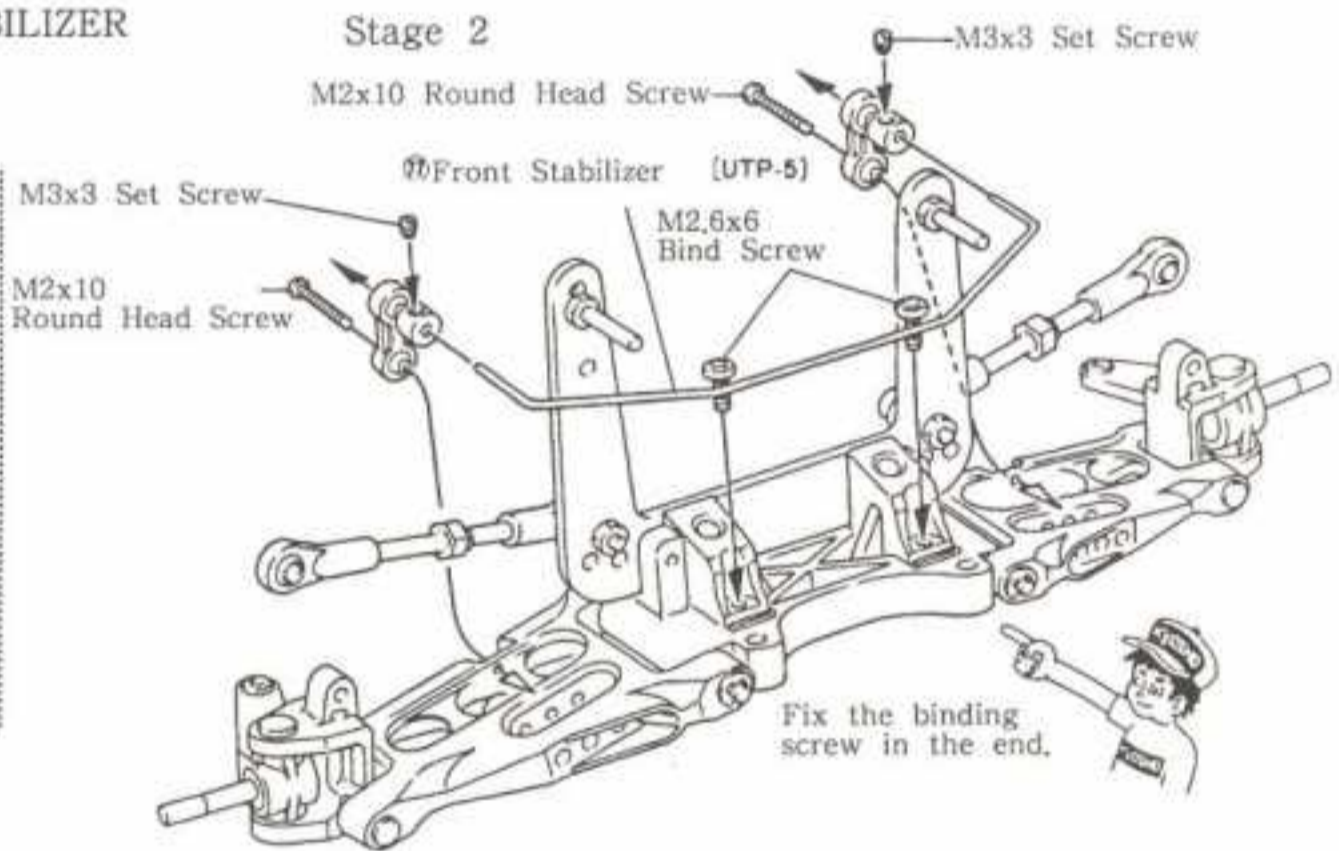

17 INSTALLATION OF FRONT BULK HEAD

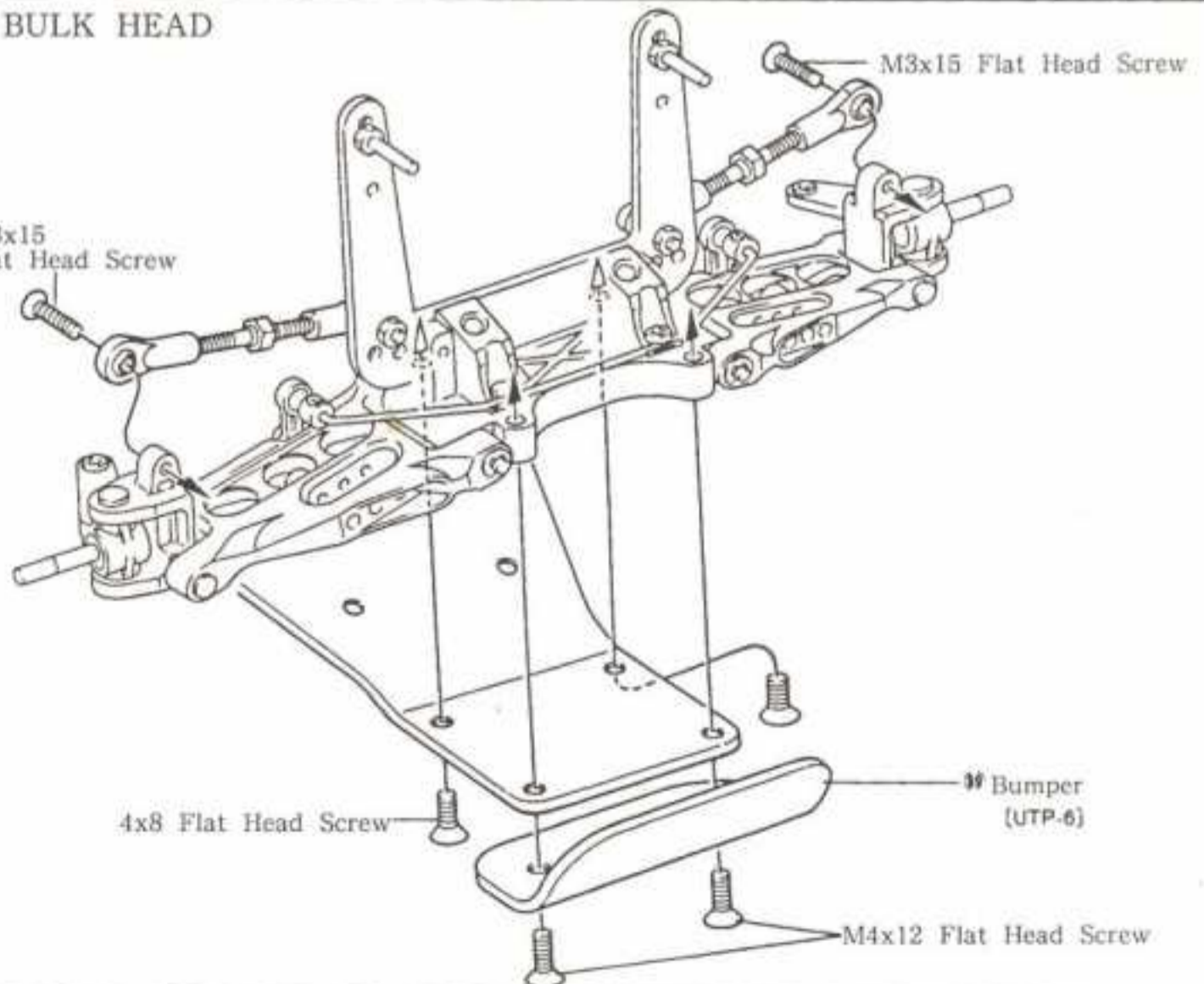

- M3x15 Flat Head 2 Screws
- M4x8 Flat Head 2 Screws
- M4x12 Flat Head 2 Screws

18 INSTALLATION OF FRONT SHOCK

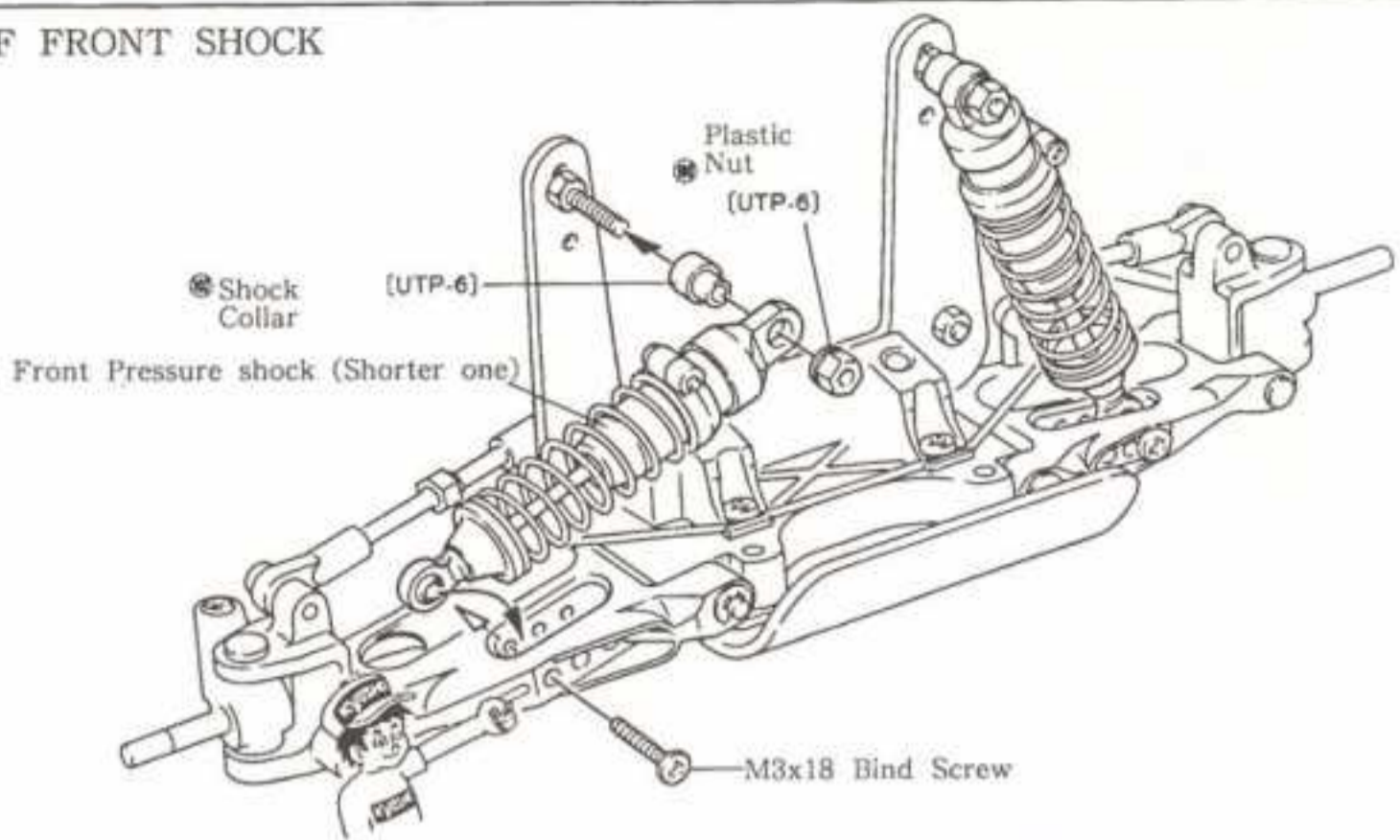
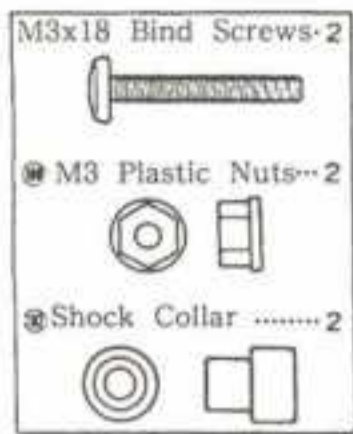

19 ASSEMBLY OF SERVO SAVER

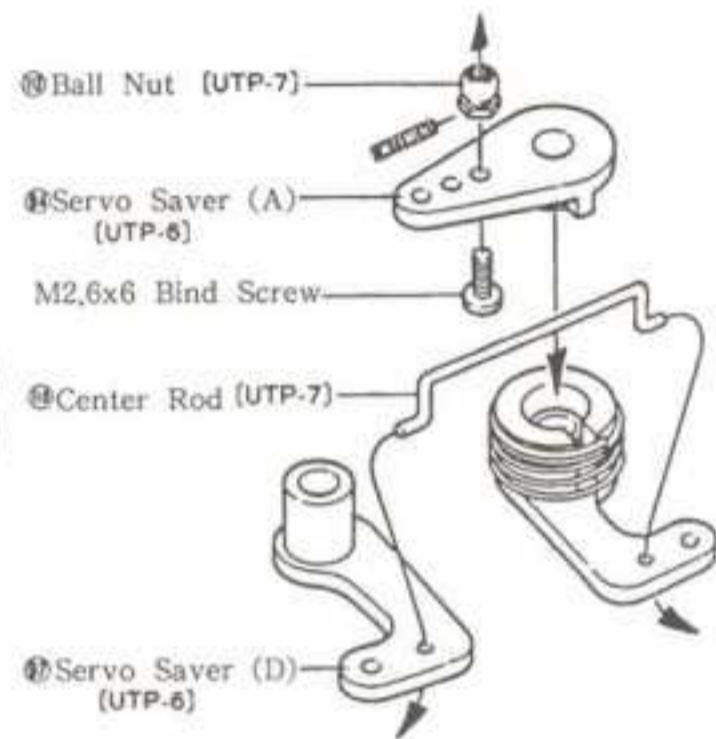
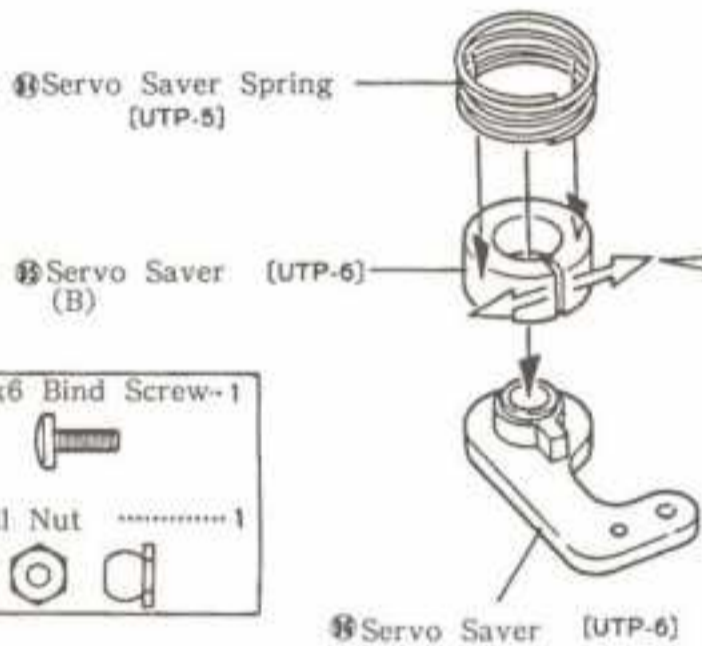

20 INSTALLATION OF SERVO SAVER

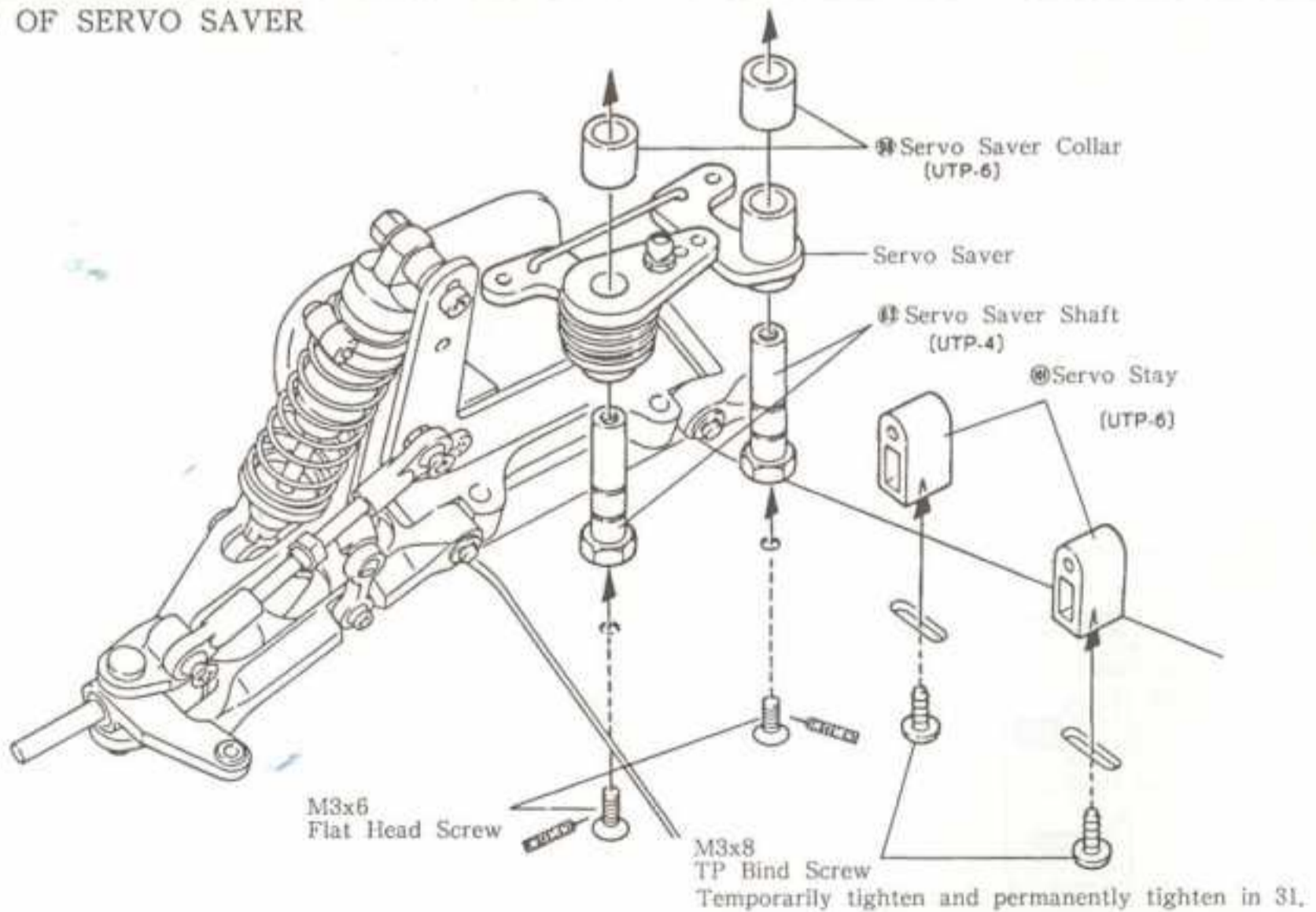
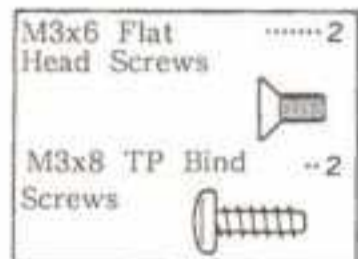

21 INSTALLATION OF TIE ROD

M2.6x12 Flat Head *4
Screws



M2.6 Nuts4



Ⓢ Ball End (S)1



Ⓢ Steering Rod (UTP-7)

Ⓢ Ball End (S) (UTP-7)

Stage 1

The more you screw in, the length of the rod becomes shorter.

M2.6x12 Flat Head Screw

This is the tie rod which has been assembled in step 4.

Be careful in the installing direction.

Side with the collar

Side with the collar

M2.6 Nut

Stage 2

22 INSTALLATION OF RADIO PLATE

M2.6x6 Bind Screw *1

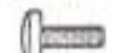

M3x6 Bind Screws *6



M3x8 TP Bind *1
Screw

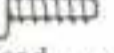

M3x6 Flat Head *2
Screws



M4x8 Truss *4
Screws



•When using separate type battery.

M3x15 Flat Head *4
Screw

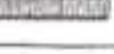

4x8 Truss Screw

Ⓢ Body Hook (UTP-6)

Install in parallel.

Stage 1

Ⓢ Radio Plate (UTP-2)

Ⓢ Antenna Post (UTP-6)

Ⓢ Wing Post (Blister B)

M2.6x6 Bind Screw (Temporarily tighten and permanently tighten after the antenna has been passed through in 33.)

M3x6 Bind Screw

M4x8 Truss Screw

Stage 2

3x6 Bind Screw

Install in parallel.

Ⓢ Radio Plate Post (UTP-4)

M3x6 Flat Head Screw

Ⓢ Stopper Post (UTP-6)

Install only when using separate type battery. (In case of stick type it is not installed)

Ⓢ Stopper Washer (Thicker one) (UTP-6)

M3x15 Flat Head Screw

23 INSTALLATION OF MOTOR CORD

Motor is not included. Recommended motors are:

- SPA 240WS
- Le Mans 360GOLD
- Le Mans H240S
- Le Mans 240SB
- Le Mans Speed 240T

SPA240WS/Le MansH-240S/Le Mans Speed 240T/Le Mans 360 GOLD

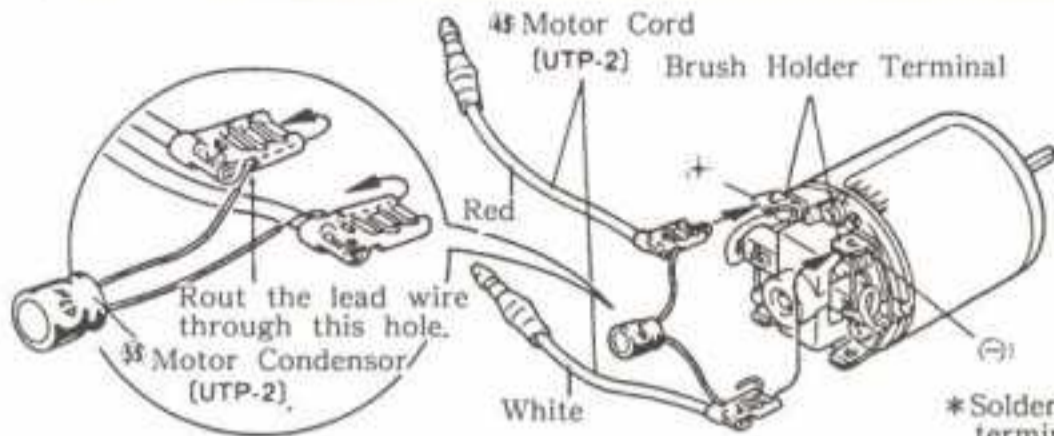

*Solder the red lead to the (+) terminal, the white to (-).

Le Mans 240SB

Repair the motor leads as shown below.

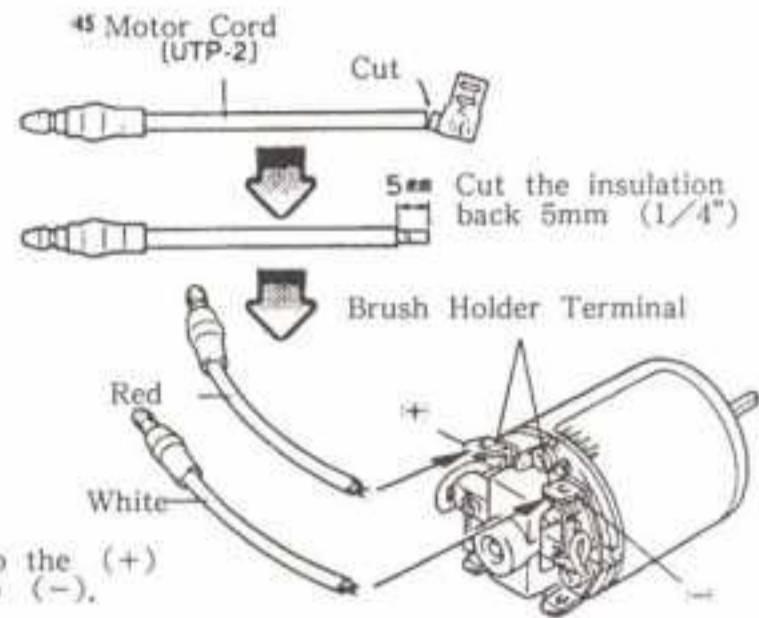

24 INSTALLATION OF MOTOR GUARD

- M2,6x6 Bind Screws-2
- M3x6 Bind Screws ...2
- M3x45 Bind Screws2

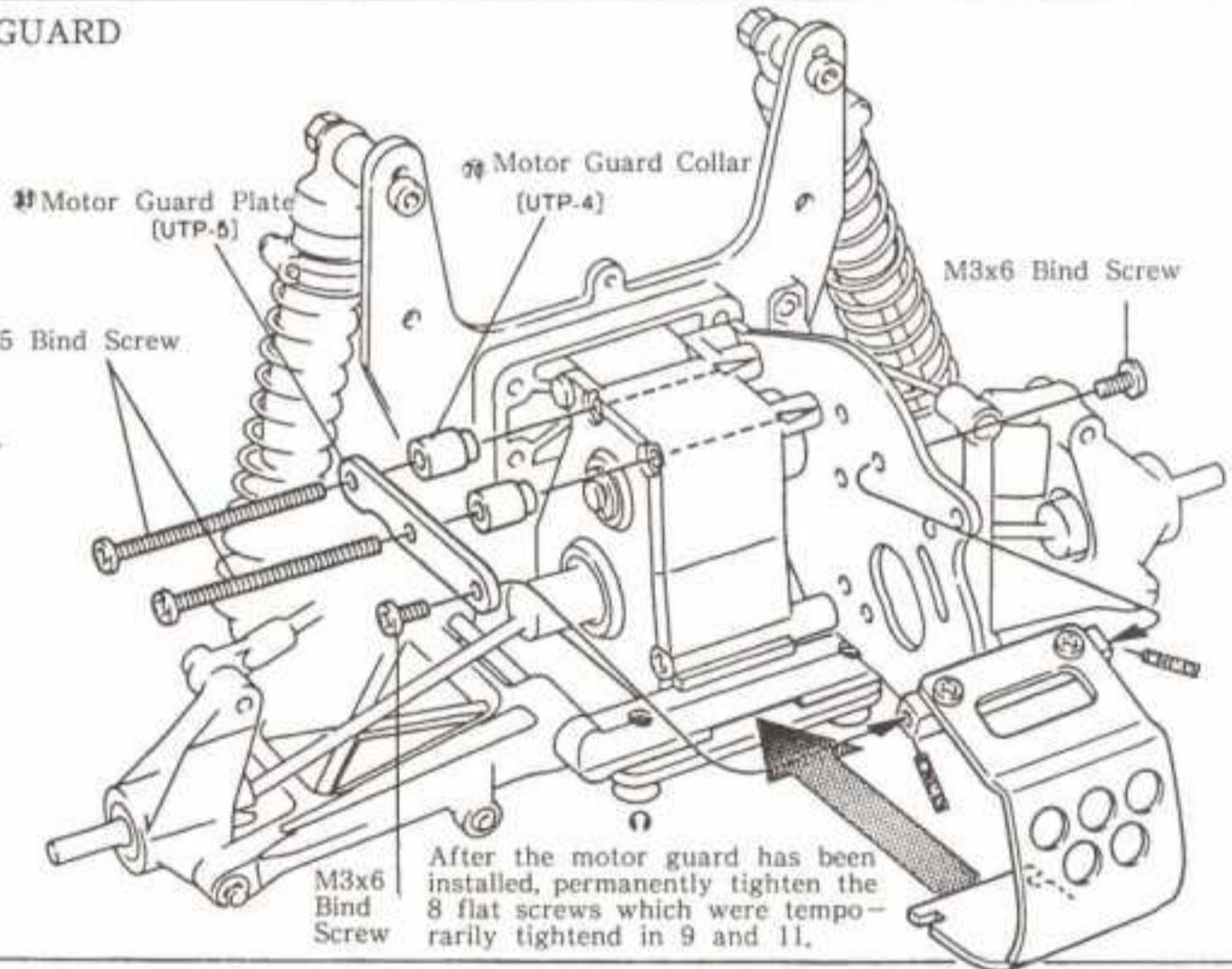
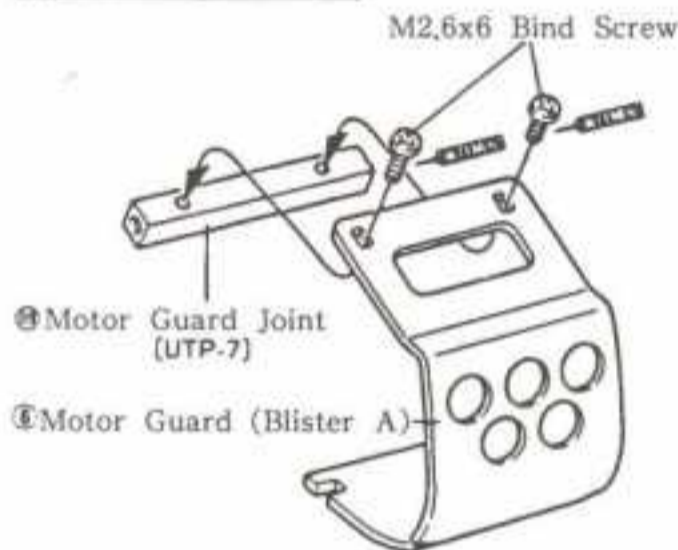

25 INSTALLATION OF CENTER GEAR

- M3x6 Bind Screw...1
- M4 Washers2
- 3/4 φ x8 Bearings.....2
- Center Gear Collar1
- Center Gear Shaft 1
- O Ring (P3 • Black)1

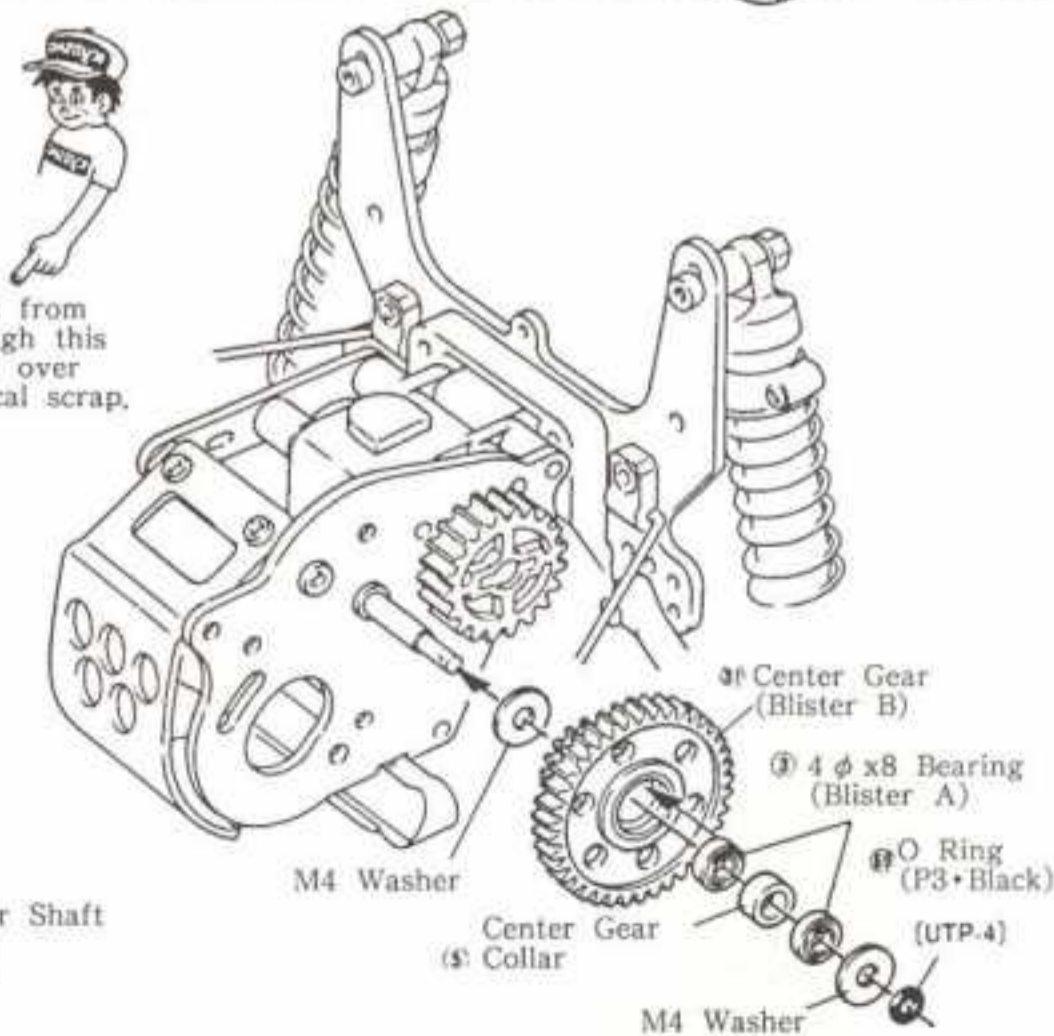
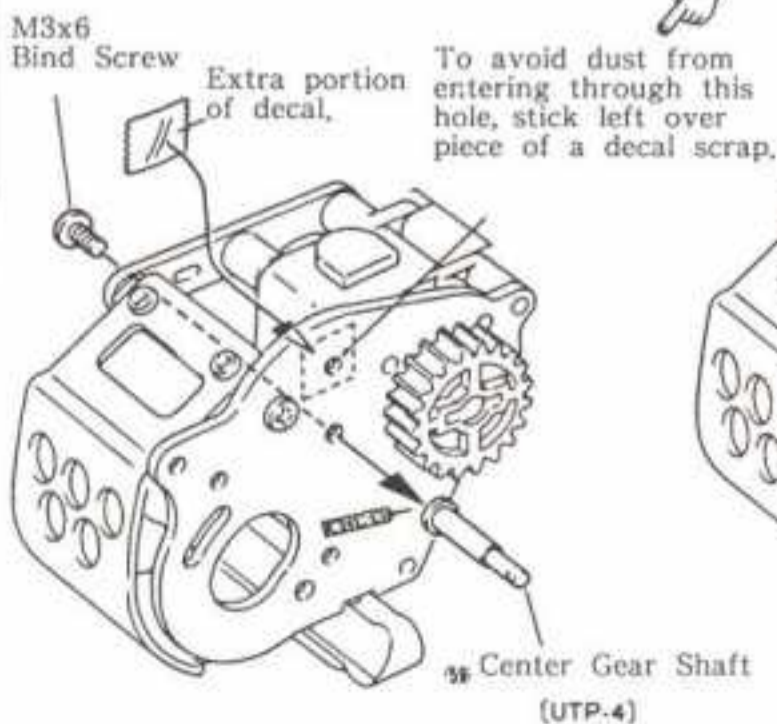

26 INSTALLATION OF MOTOR

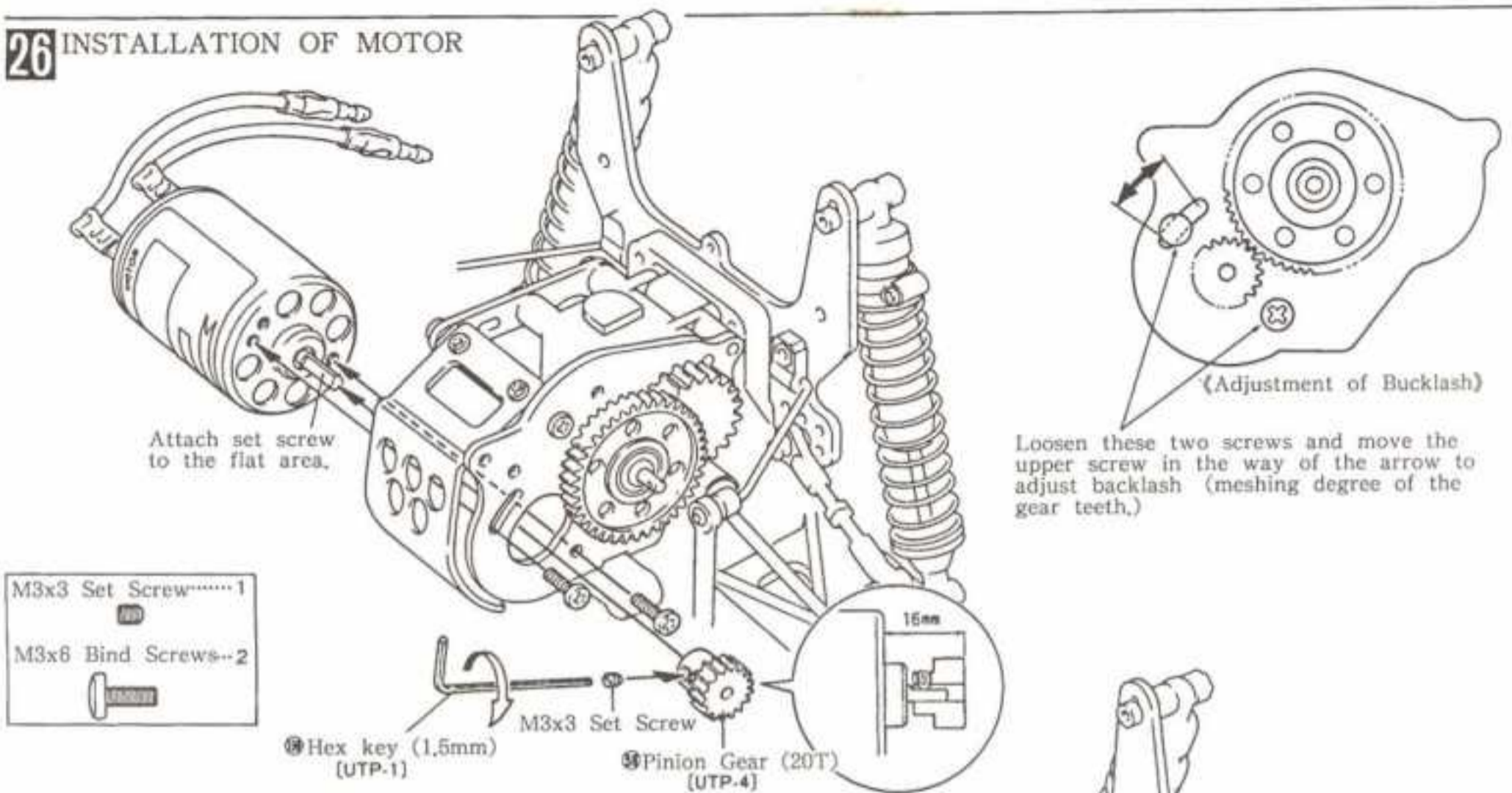

27 INSTALLATION OF GEAR COVER

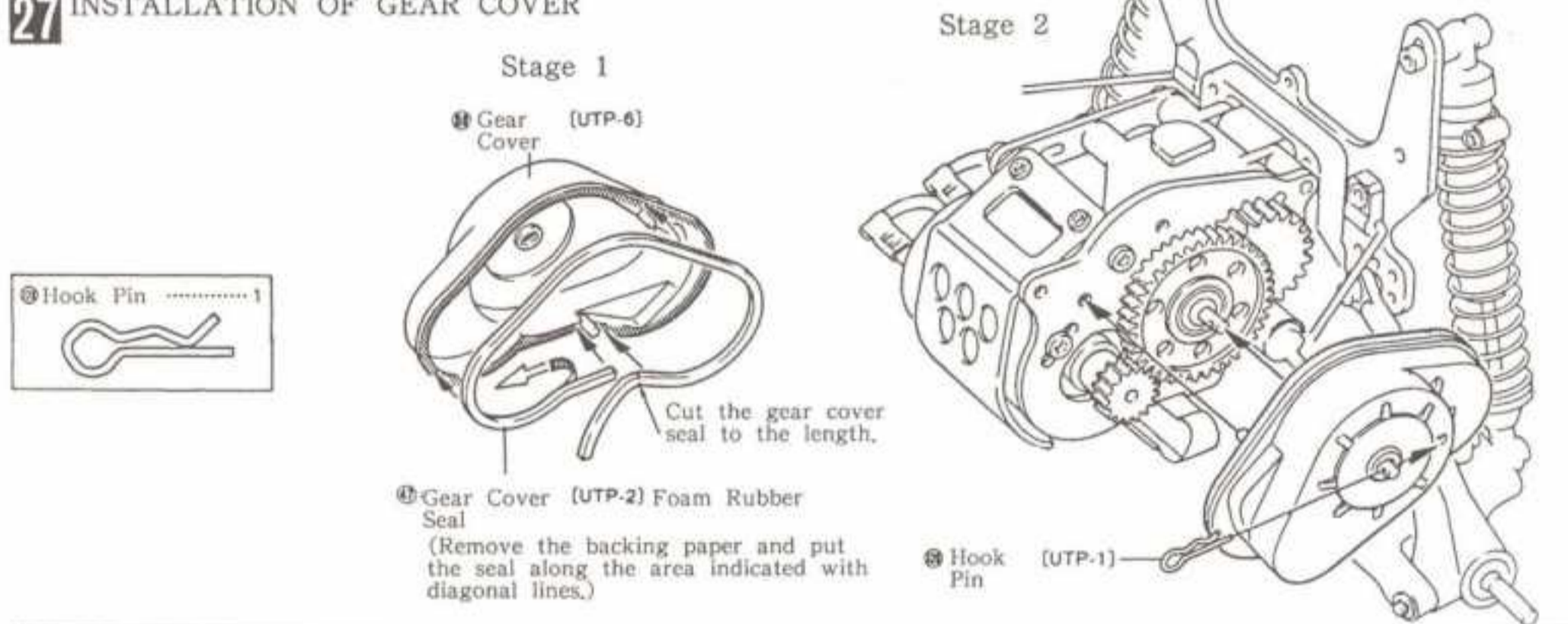

28 ASSEMBLY OF WHEEL AND TIRE

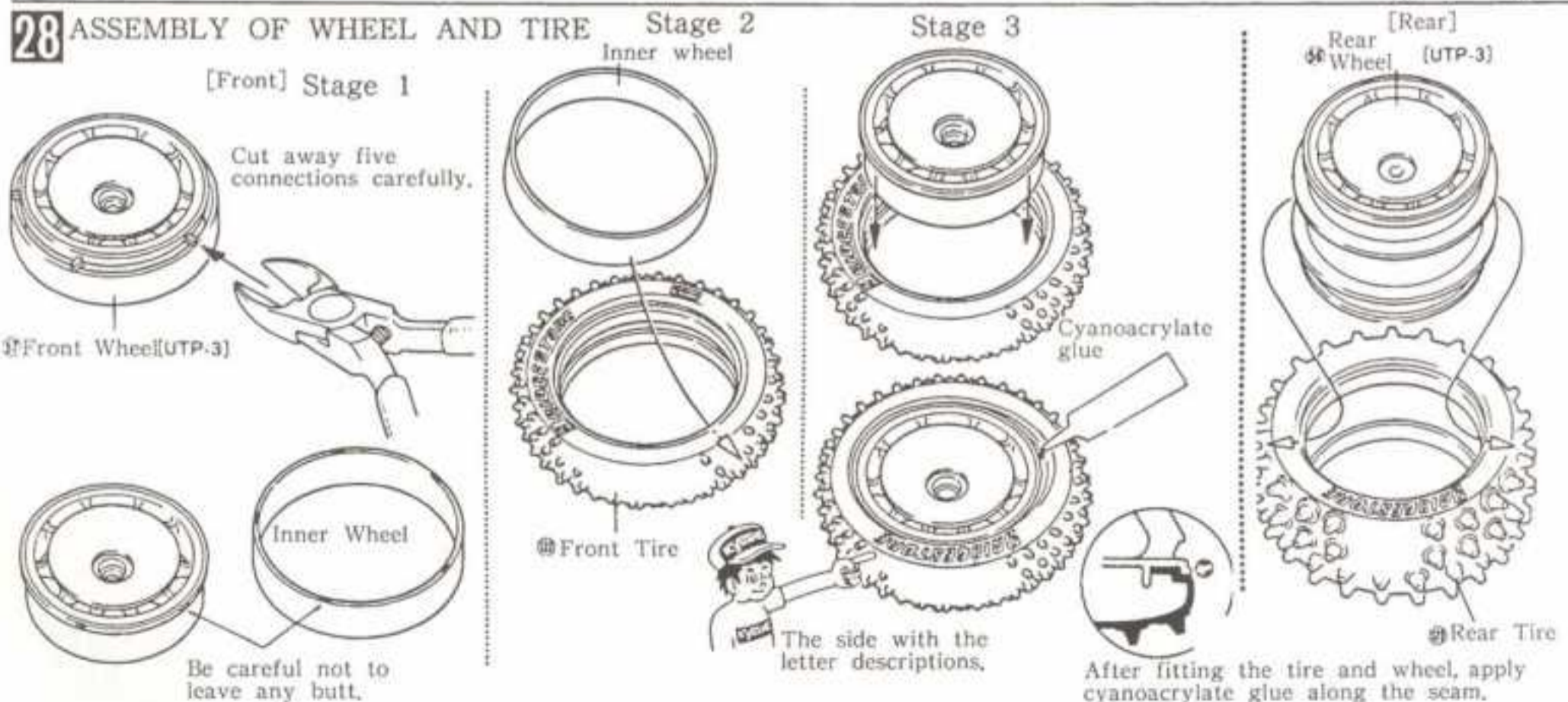

29 INSTALLATION OF TIRE

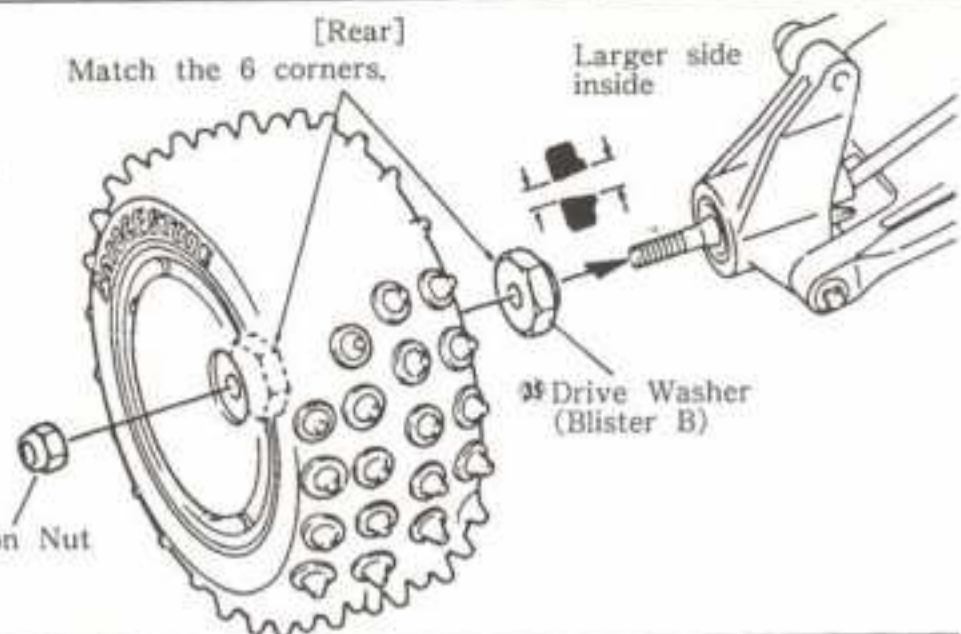
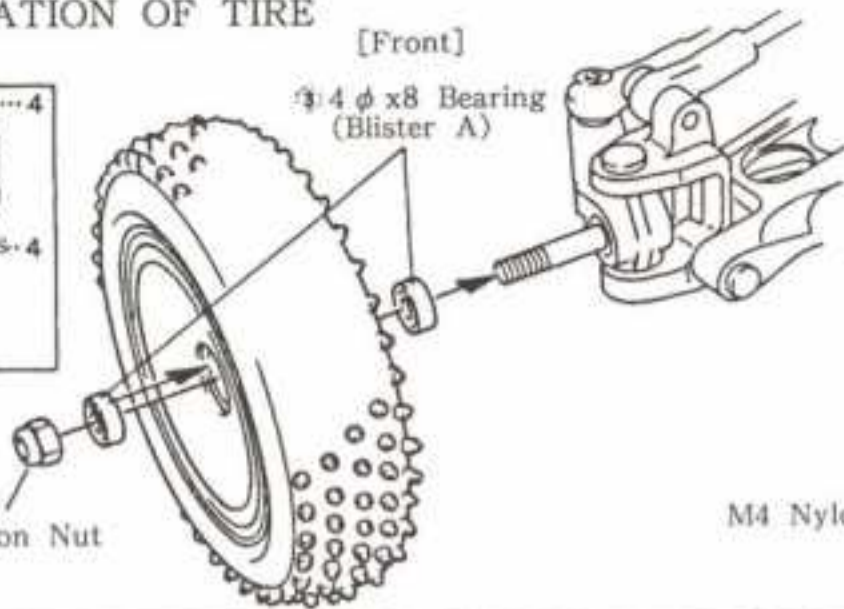
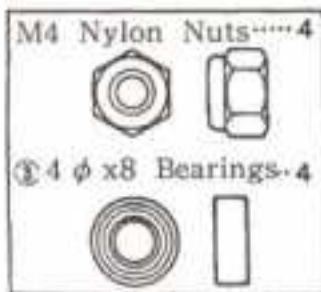

INSTALLATION OF RADIO UNIT • LINKAGE

30~34

30 HOW TO CHECK RADIO SYSTEM

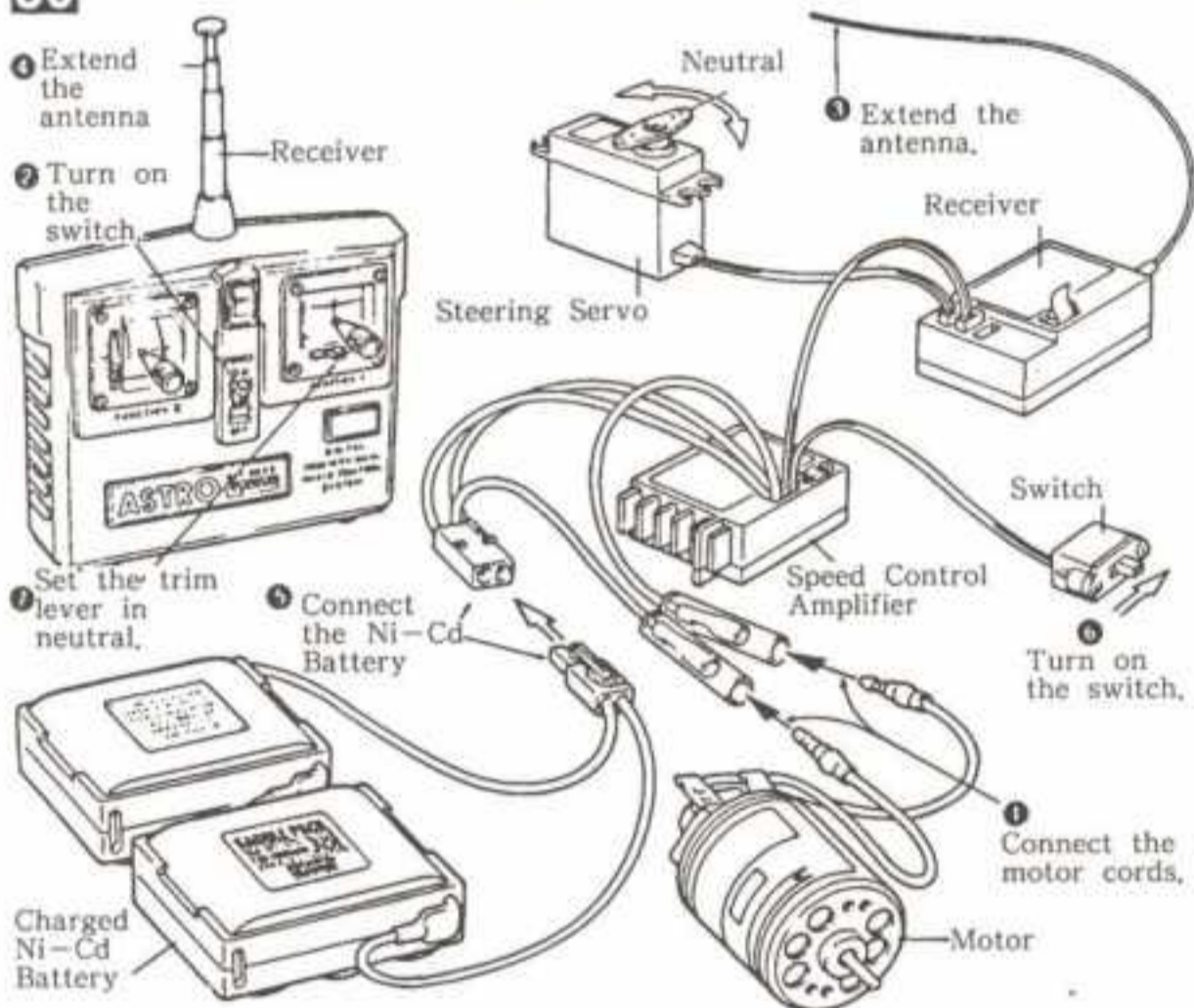

*Operate the radio control units in order of the numerical figures.

A two channel radio is composed of things like a transmitter, receiver, servos, and battery.

- *Transmitter----- It is in effect a control box. Signal waves are transmitted through an antenna according to the stick movements.
- *Receiver ----- Receives the signals from the transmitter and send them to the servos.
- *Servo ----- They really move the control mechanism of a model car in accordance with the signals from the receiver.
- *Antenna ----- An antenna on the transmitter sends signals, and
- *Trim Lever----- They will adjust the neutral position of servos, thus regulate the steering and advancing controls finely.
- *Battery----- You can tell the amount of electricity in a Meter and how the signals are emitted.
- *Servo ----- They are intermediate devices on the servos to activate the controls. There are several types in shape. They should be selected depending upon the usage.

When switch on the radio...
Get the switches in order from transmitter to receiver.

When switch off the radio...
In order from receiver to transmitter.

31 INSTALLATION OF STEERING CHECK

Stage 1 Cut off shaded part.

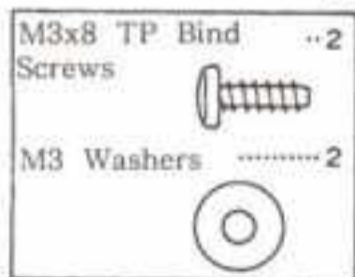

Enlarge the hole with an awl so that the control rod can fit easily.

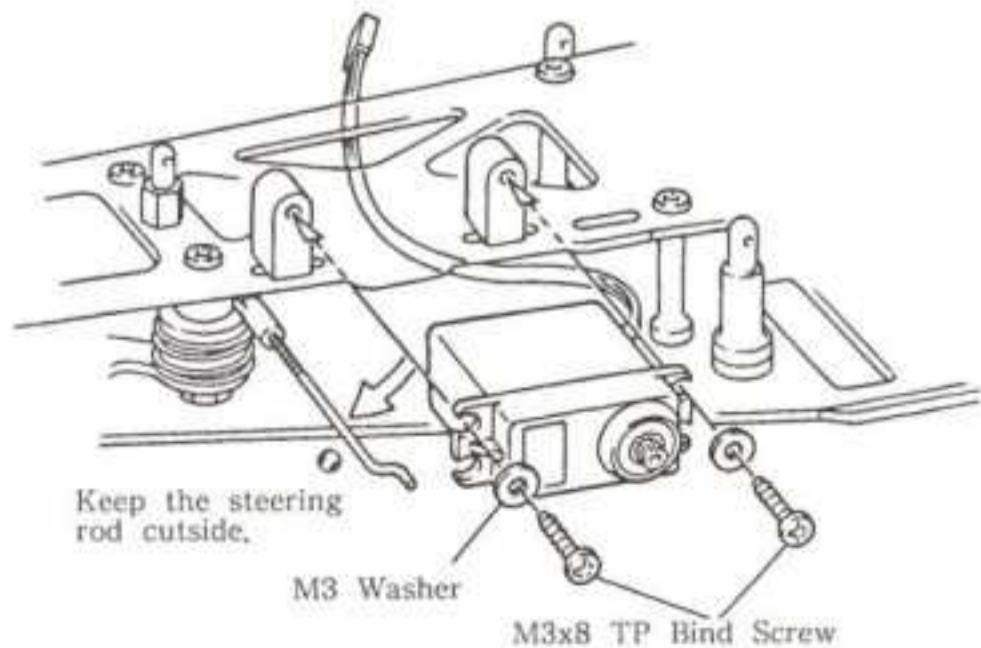
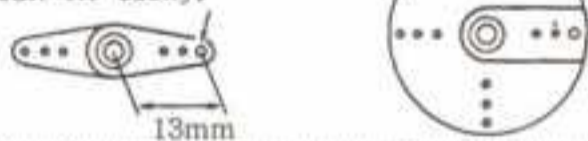

(1) Adjust servo by moving back and forth.

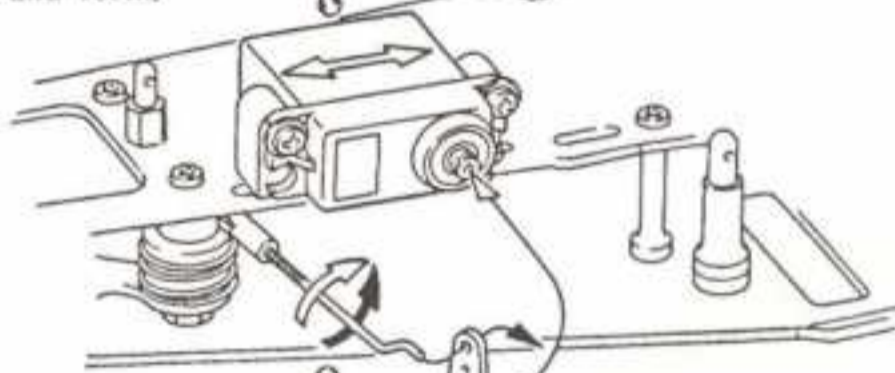

(2) Adjust by screwing in or out the rod.

Use the screw provided with your radio units.

When the servo horn is in the neutral position, adjust with (1) or (2) so it will become A=B.

If ok permanently tighten.

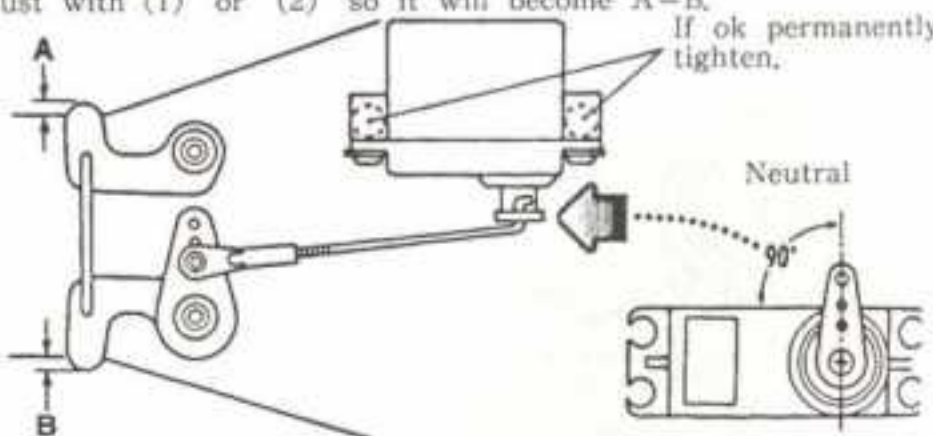

32 INSTALLATION OF AMP

IN GENERAL THERE ARE 3 TYPES OF SPEED CONTROL AMP, SMALL TYPE, SERVO TYPE AND OBLONG TYPE.

(SMALL SIZE • SERVO TYPE • OBLONG TYPE COMMON)

Have finger prints and oils removed and cleaned from the surface of the amp and mechanism plate where the both surface double sided tape is to be attached.

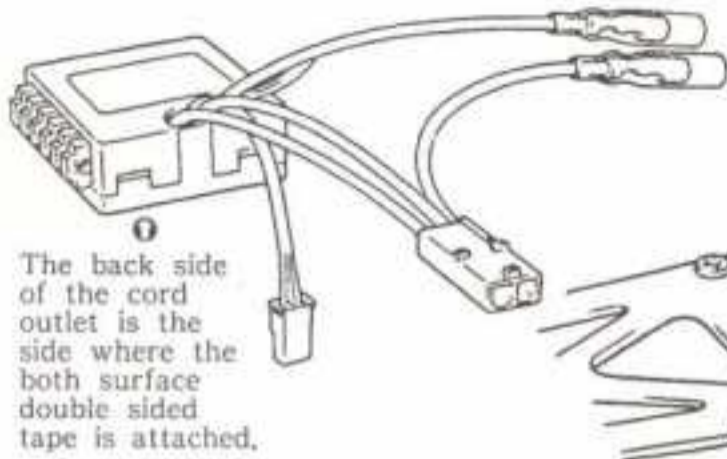

The back side of the cord outlet is the side where the both surface double sided tape is attached.

(In case of Amp with Switch)

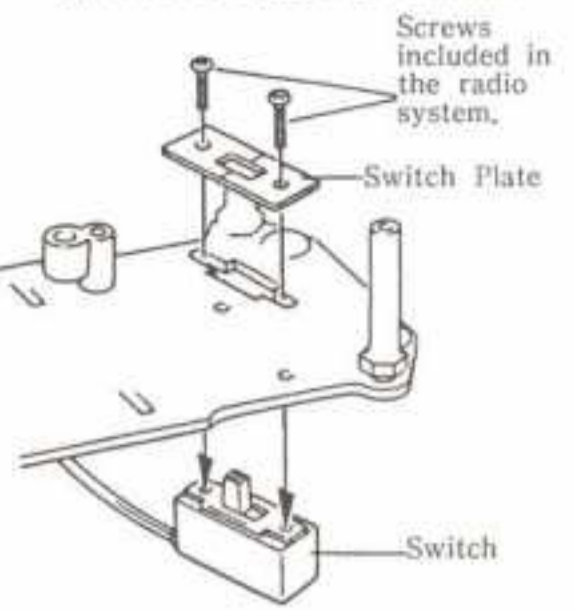

Screws included in the radio system.

Switch Plate

Switch

- Install so that the cords exit will come to the left side.
- Cut the (49) double sided tape (UTP-2) to match the amp and switch.

(SMALL TYPE)

(SERVO TYPE)

(OBLONG TYPE)

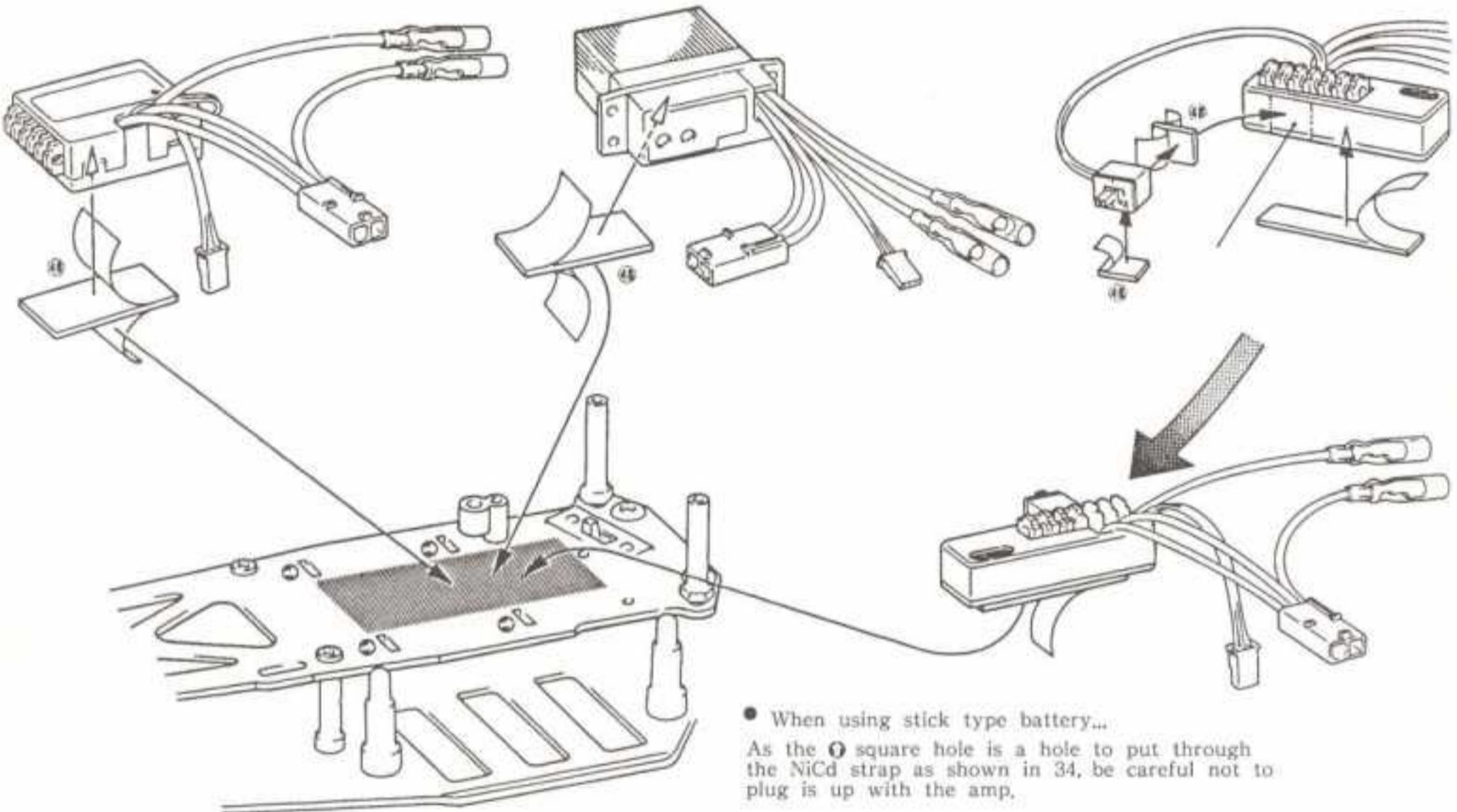

• When using stick type battery... As the (1) square hole is a hole to put through the NiCd strap as shown in 34, be careful not to plug is up with the amp.

• AFTER THE AMP HAS BEEN INSTALLED...

Stage 1 Joint the connector being careful of the motor cord color.

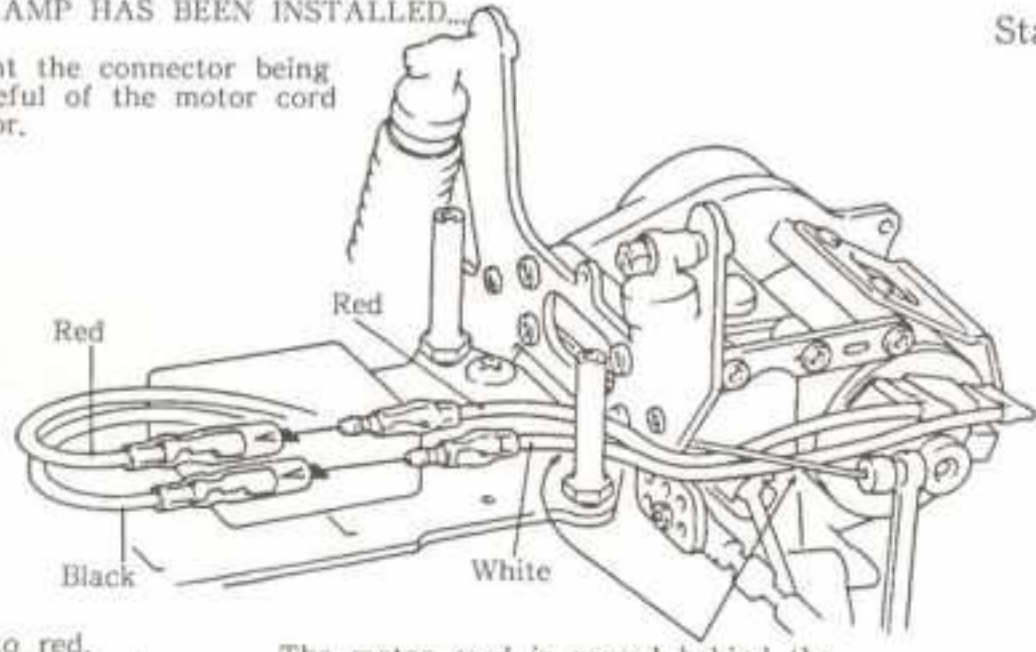

Join red to red, white to black cord.

The motor cord is passed behind the wing post from underneath the stabilizer.

Stage 2 In case the cord is too long, bundle it neatly with the strap.

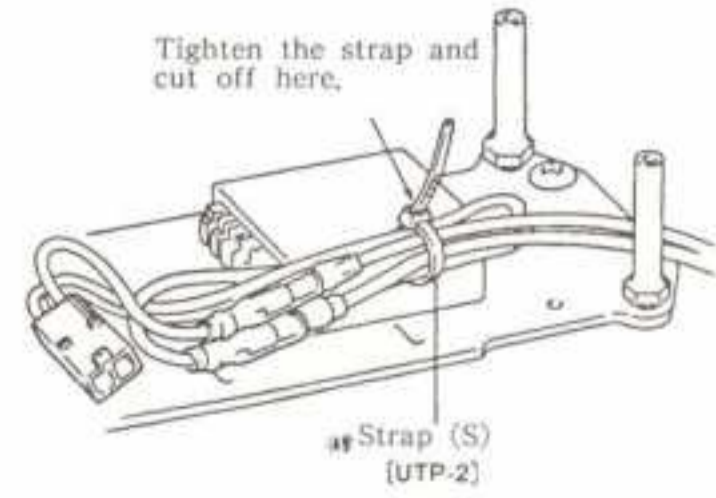

Tighten the strap and cut off here.

Strap (S) [UTP-2]

33 INSTALLATION OF RECEIVER

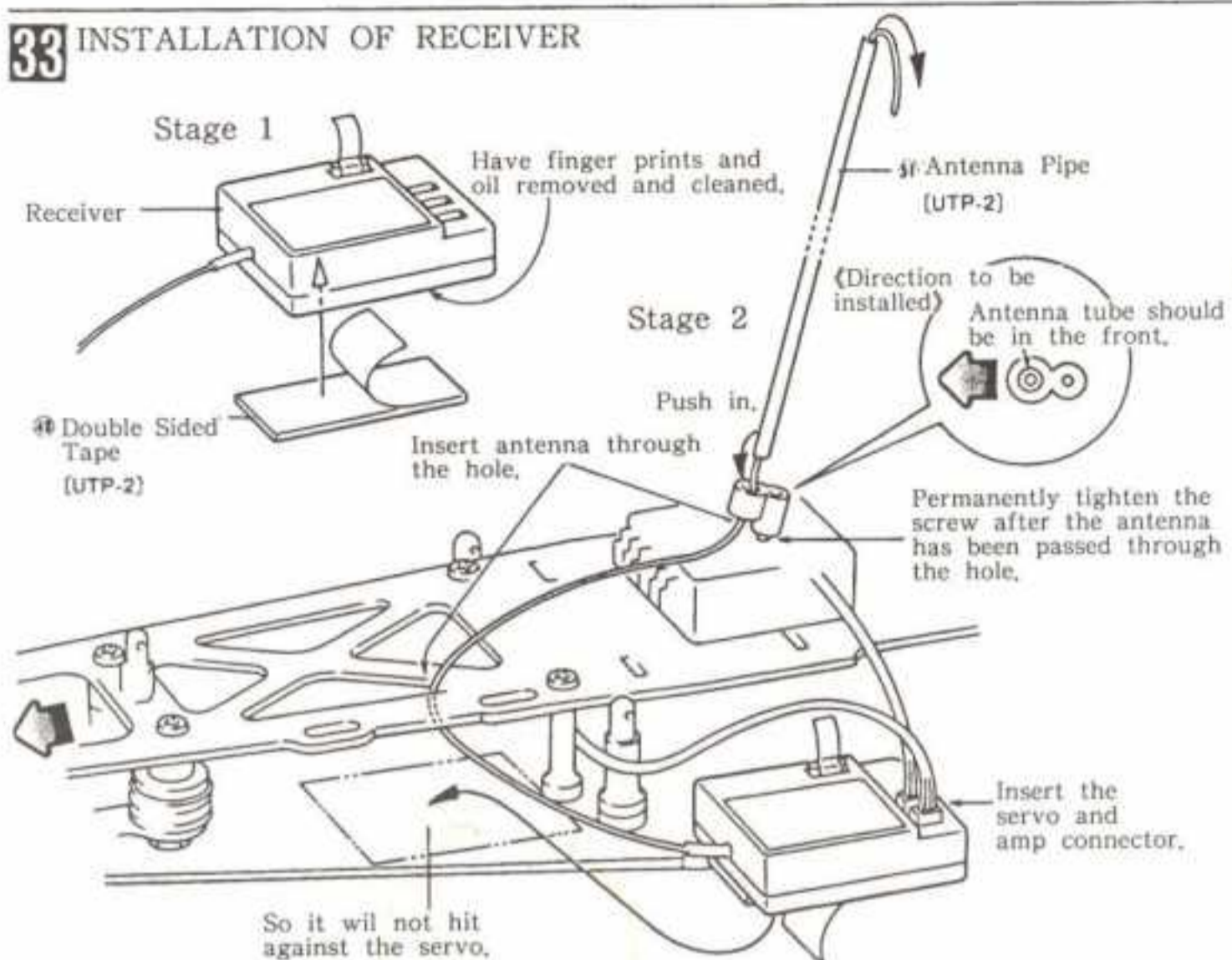

Stage 3
Bundle the cord and strap it onto the mechanism plate.

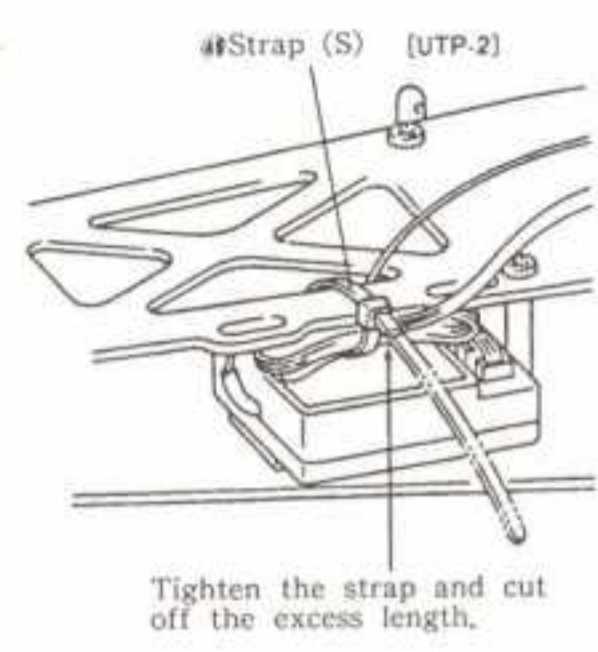

34 INSTALLATION OF BATTERY

Stage 1 Set the saddle pack onto the chassis in the direction shown in the diagram.
Stage 2 The terminal of the battery connector black cord should be bent as shown in the diagram and passed in between the post.

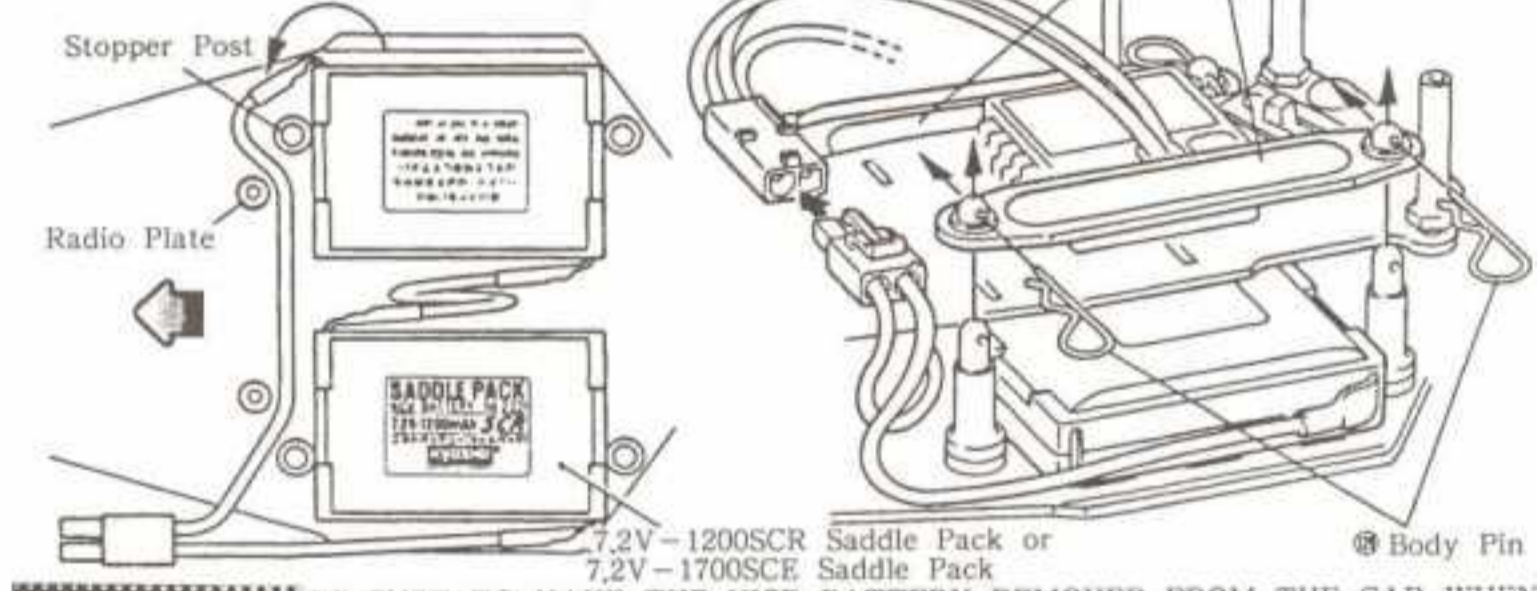

KYOSHO
No 2331
Kyosho offers 7.2V-1200SCR and 7.2V-1700SCE Saddle Pack as recommended battery for experienced driver. (Incl. Hard battery case)

BE SURE TO HAVE THE NICD BATTERY REMOVED FROM THE CAR WHEN IT IS NOT BEING RUN OR BEING STORED.

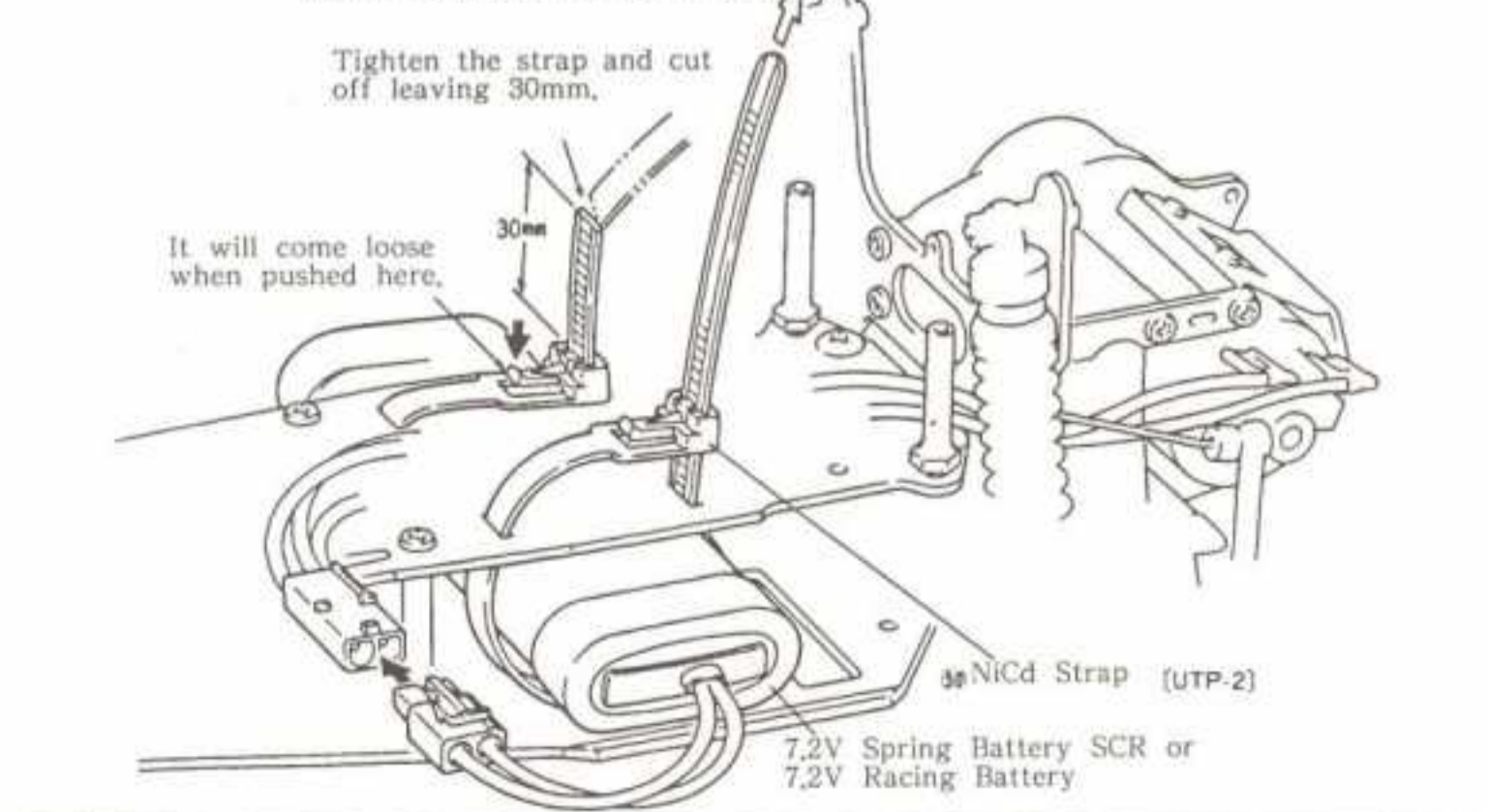

KYOSHO
No 2310
Select a high performance NiCd battery pack which is powerful enough to drive a model buggy car vigorously. Kyosho offers the 7.2V Sprint Battery SCR which is prepared for the buggy car specially.

35 CUTTING OF BODY AND WING

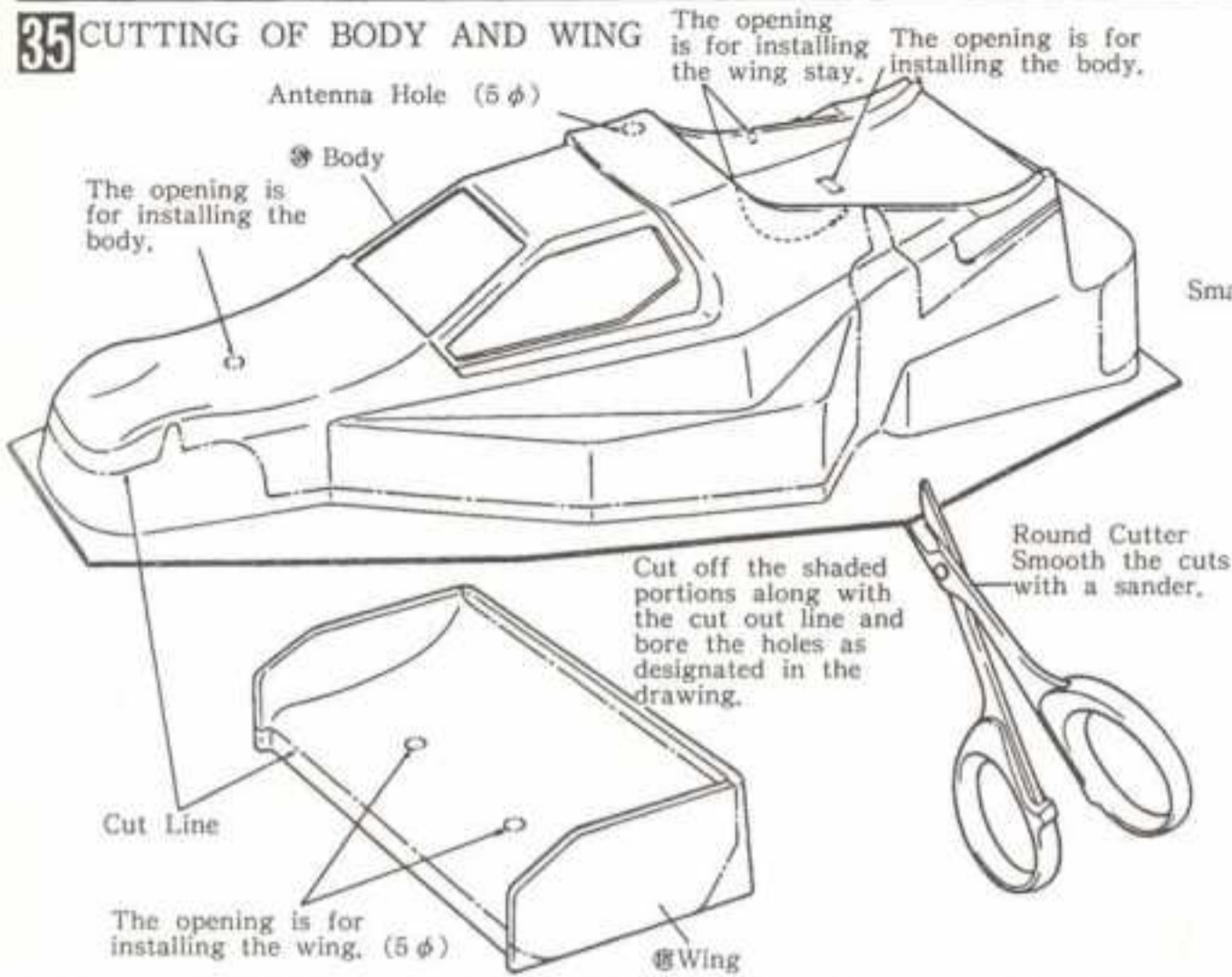

(Rear Part of the Body)

KYOSHO

These special Lexan Scissors make trimming bodies a breeze and the sander comes in handy for finishing the rough edges.

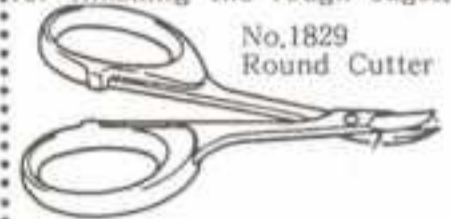

36 PAINTING

First wash the body to remove any oil or dirt. Rinse thoroughly. Paint the inside of body. You can obtain a color scheme by masking a portion with tape then removing the tape and painting. Apply the lightest color last.

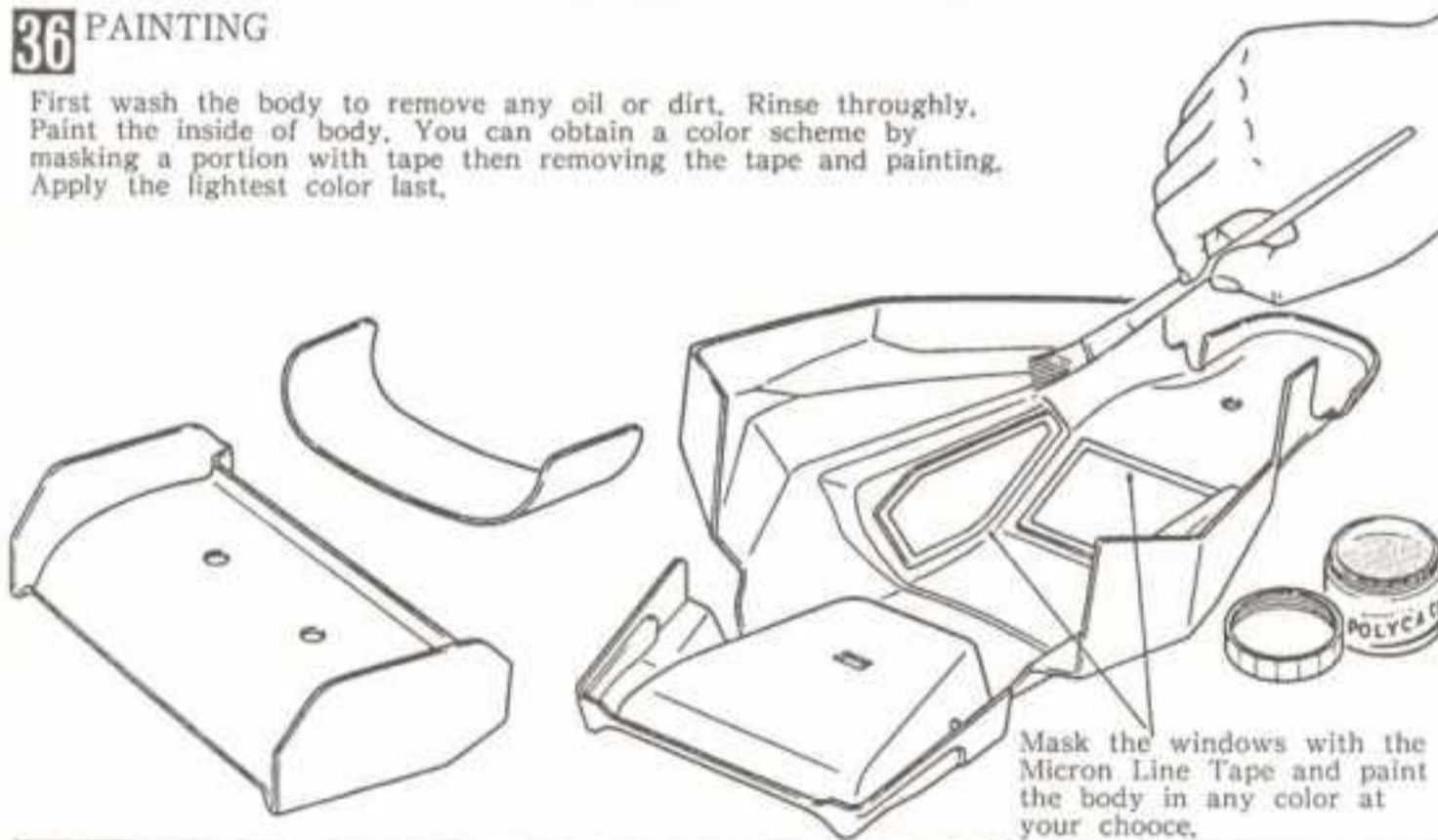

KYOSHO

Micron Line Tape
No.1841...1mm
No.1842...1.5mm
No.1843...2.5mm
Color
White, Red
Yellow, Green
Blue & Black



KYOSHO

Polica Color No.2230
White,Red,Yellow,
Green,Blue,Sky Blue,
Orange,Black,Violet,
F. Pink, Yellow Green
& Orange



37 APPLY OF DECAL

Cut off the decals with a scissors without leaving any blank space. The below decals should be attached in one area (block). Do not cut off in scattered pieces. Do not rush to attach the decal without planning. Attach after determining the position by placing it on the location you would like to attach with the back protector sheet still on and then attach. To prevent air bubbles from forming start by sticking the center part of the decal onto the surface first and then rub towards the outside and attach. (Special care is necessary when attaching large size decals.)

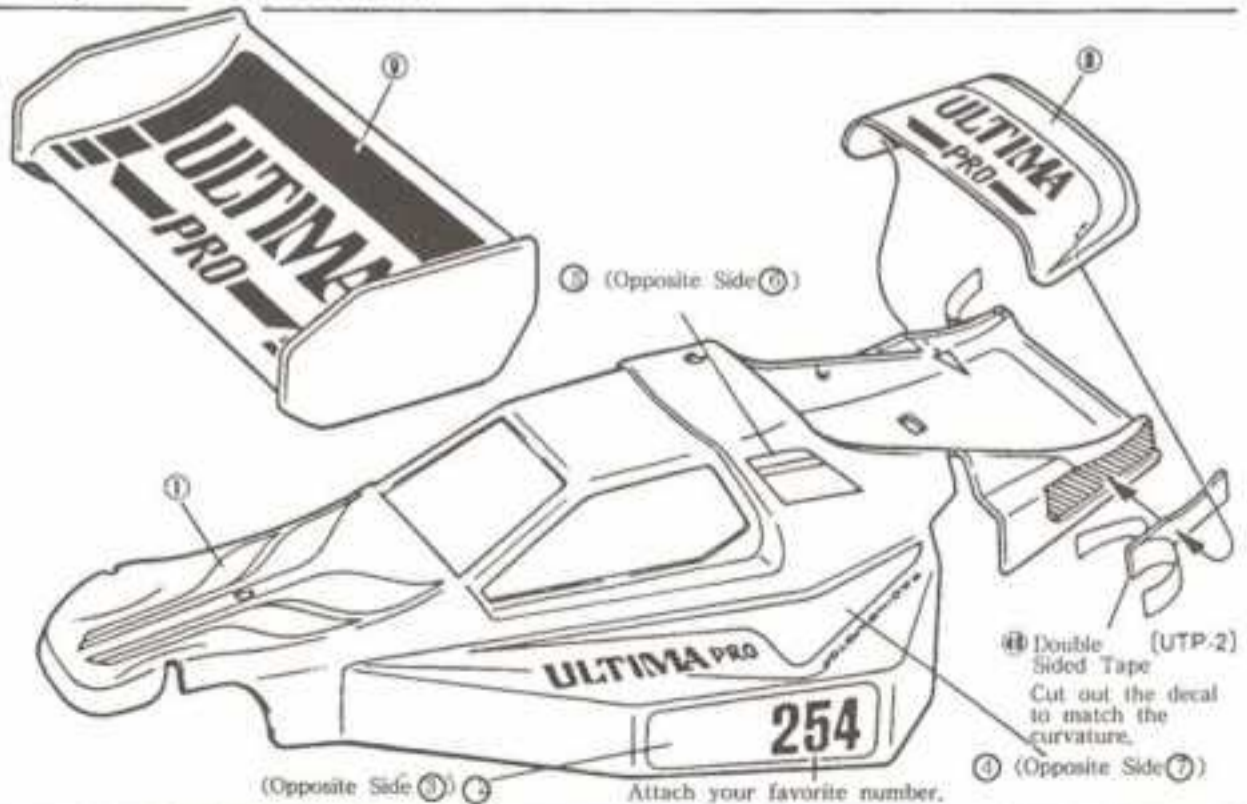

38 ASSEMBLY OF WING AND INSTALLATION OF BODY

Assemble it in order from ①-⑤

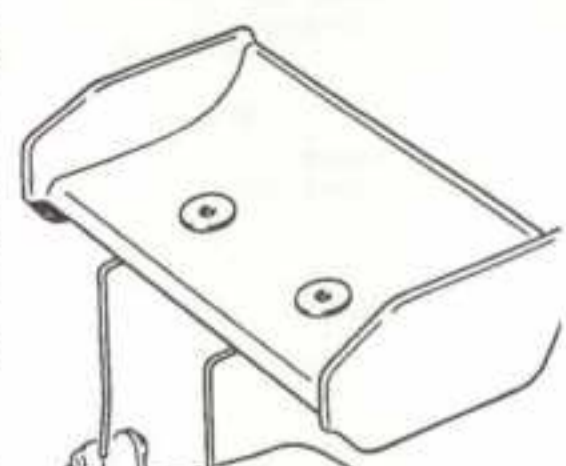
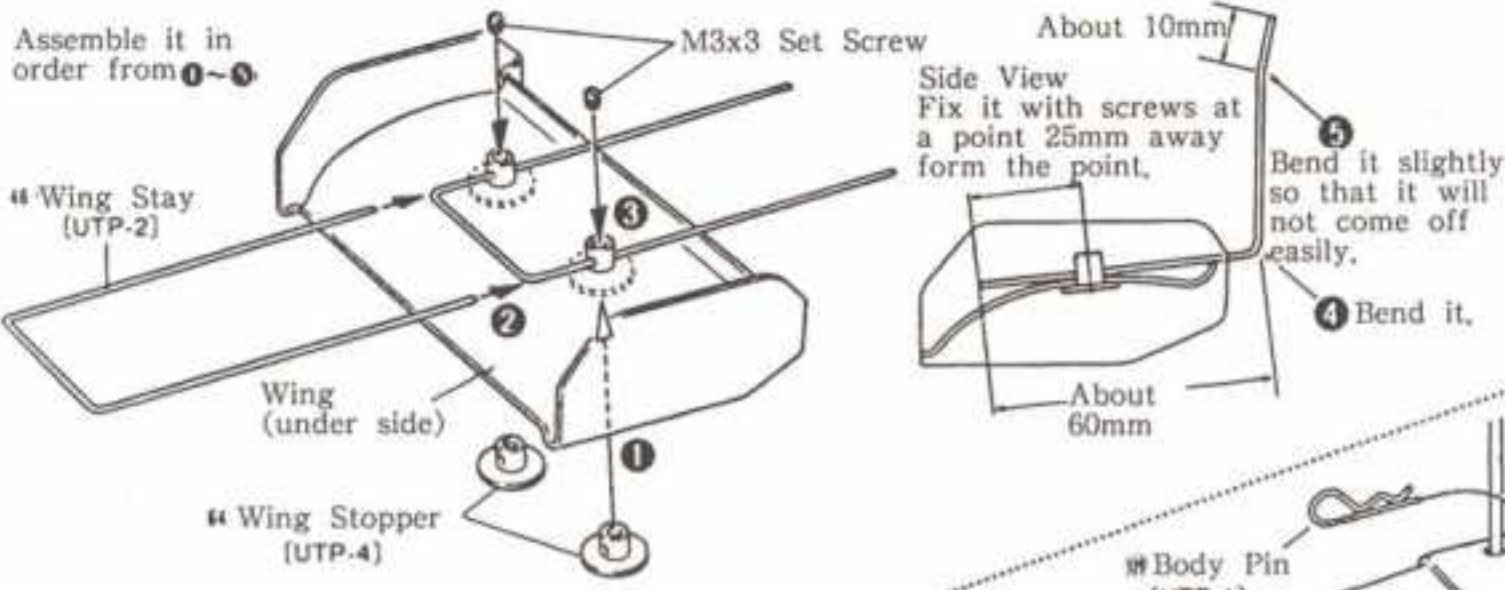

- M3x3 Set Screws... 2
- Body Pins 2

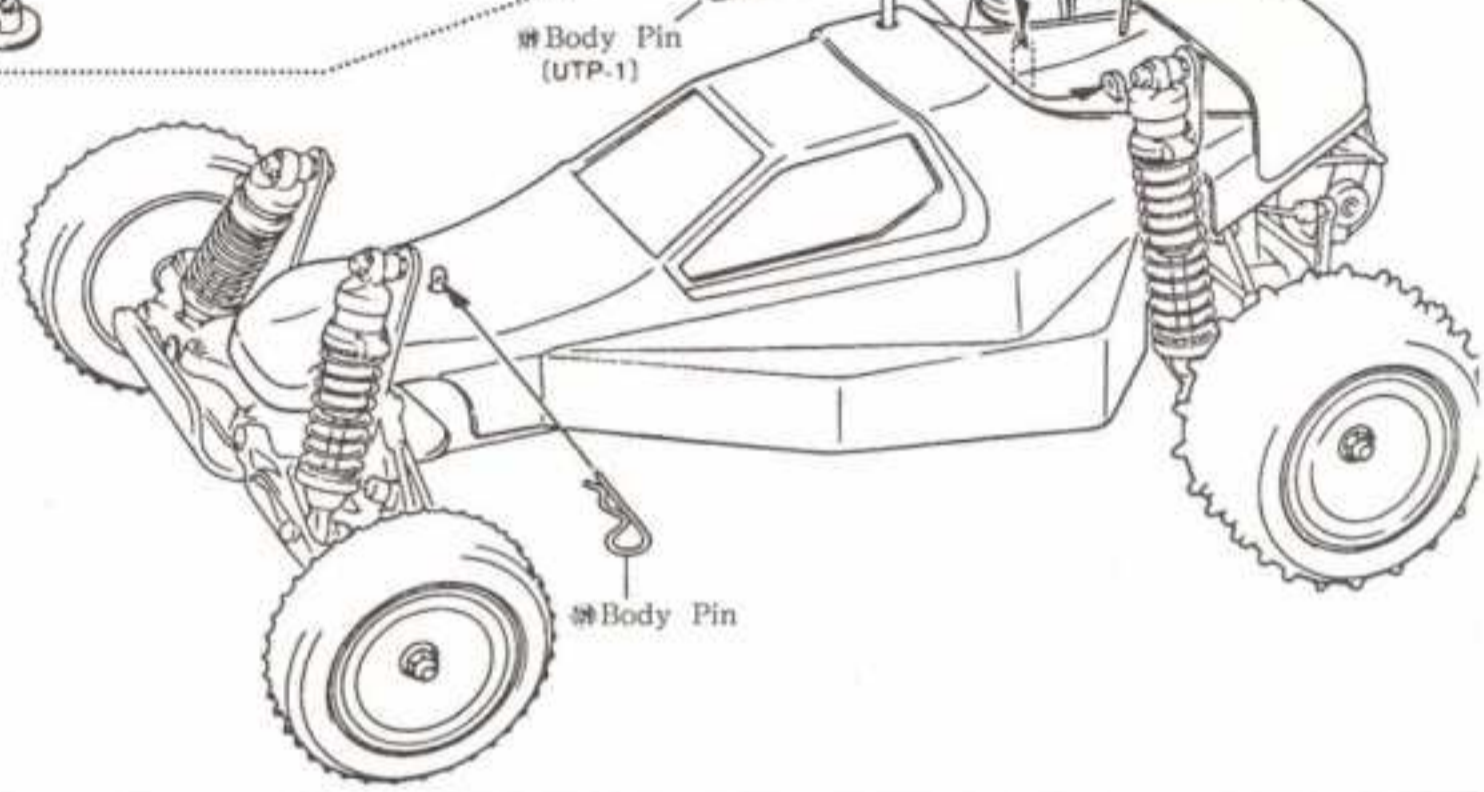

[Adjustment of Ball Differential after Assembly]
The ball differential gear has been adjusted as shown at the left column. But after the assembly, take a look in the following ways if the cap screw is tightened properly.

① Remove the gearbox cover first, then put a piece of foam rubber or thick paper between the center gear and the pinion gear to lock them.

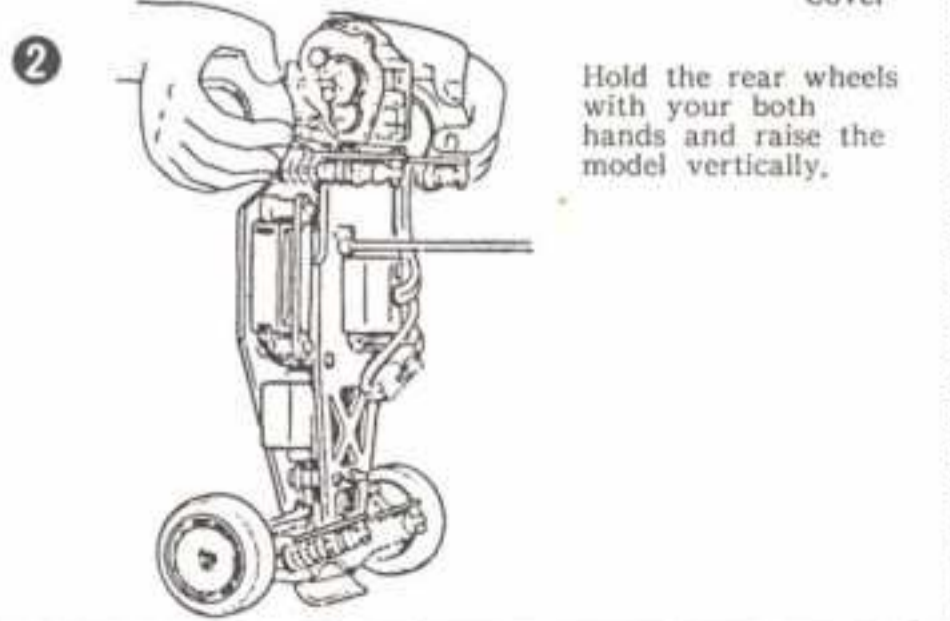
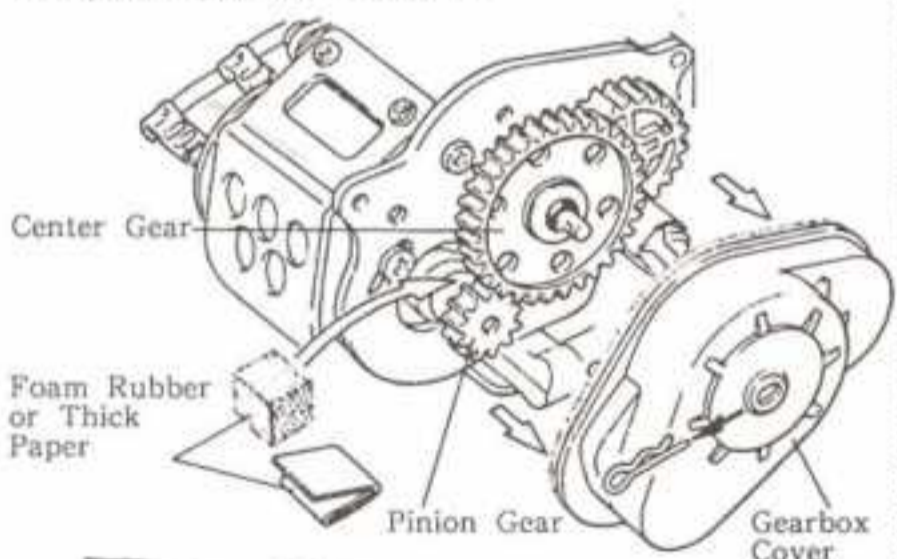

③ Swing the model car upward by holding the rear wheels. The best adjusted model will be raised to become horizontal and not farther.

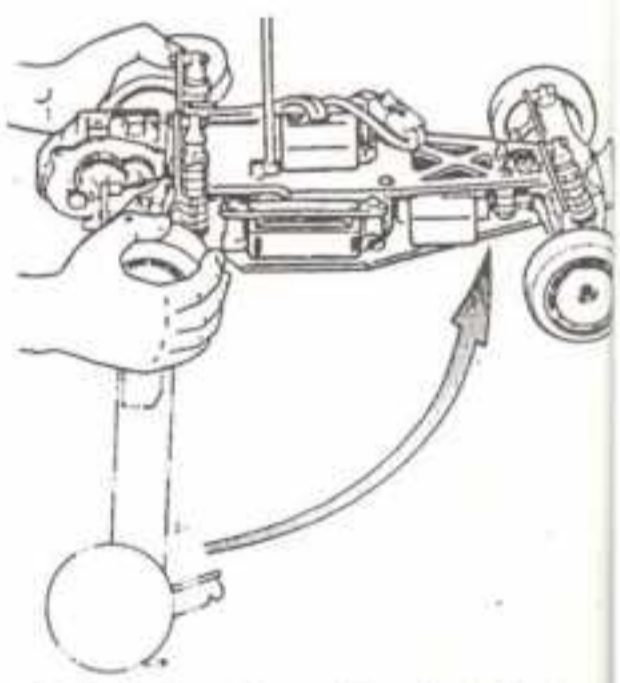

④ If the model goes up beyond the horizontal position, it indicates that the cap screw has been tightened excessively. Conversely if it does not reach to the horizontal line, tightening of the cap screw is inadequate. In such a case remove the flat headed screw which is fastening the rear hub and readjust the cap screw as shown. (During this procedure, hold the right side wheel to lock the shaft.)

M3x12 Flat Head Screw

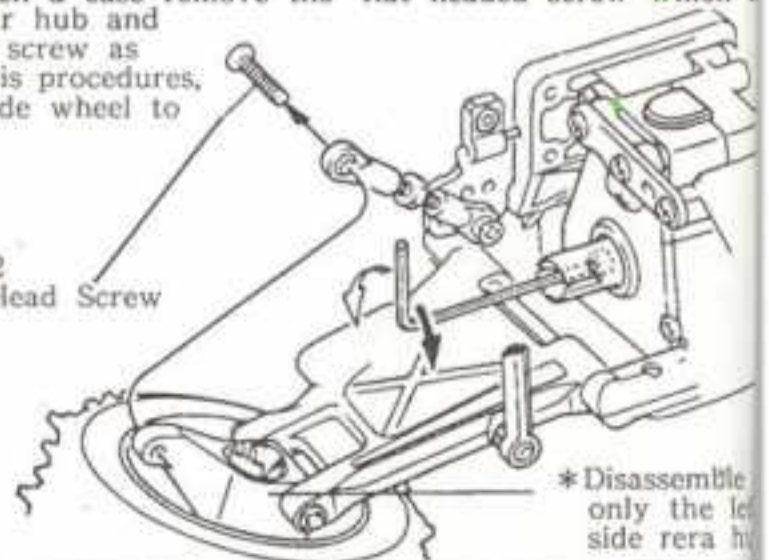

SETTING GUIDE (1)

[Basic Setting 1]

Place the model car on a flat surface, and keep the car with the maximum body clearance, and adjust length of the front and rear upper rods so that the wheels stand at a right angle to the ground.

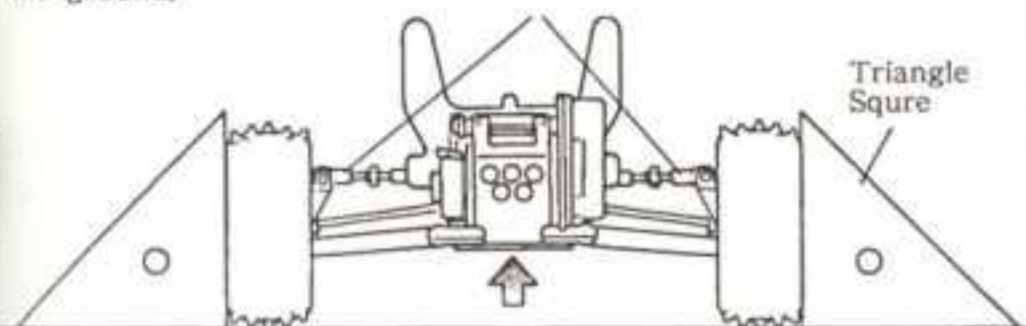

• The way of adjustment of upper rod.

As same as tie rod, it can be adjusted in the way right picture.



• By adjusting the upper rod shorter, you will have a trait of negative camber. With negative camber adjustment on the front wheels, you will have sharper steering tendency, while on the rear wheel, the gripping power becomes higher.

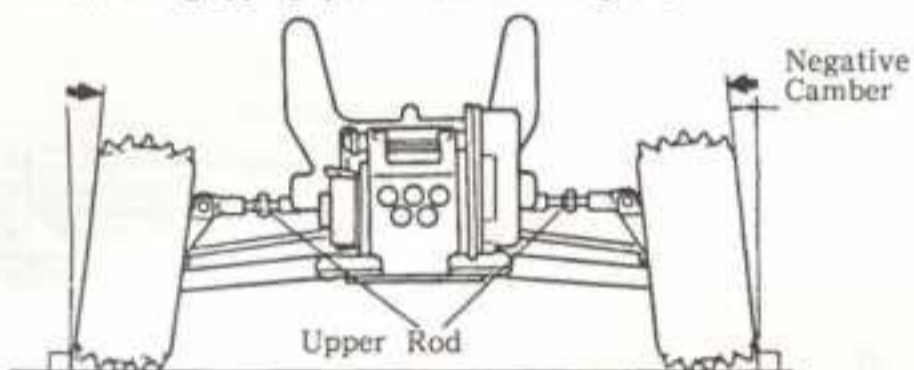

• By lengthening the upper rod, positive camber adjustment is gained. With positive camber on the front wheels, you will have a trait of under steering, while on the rear wheel you will have the car with over steering traits.

*Excessive positive camber adjust may make the swing shaft dislocated.

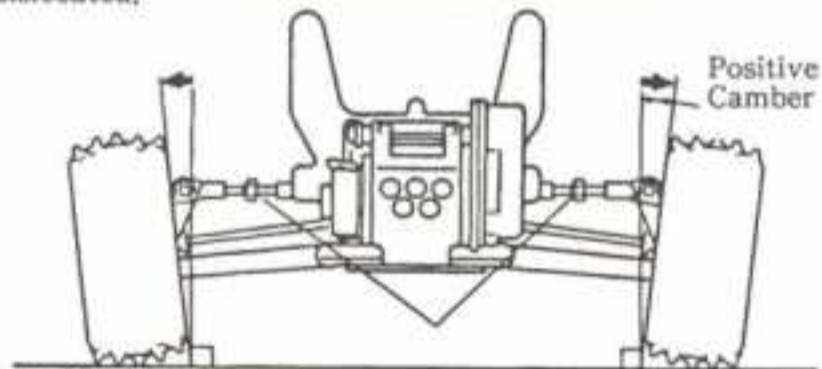

[Basic Setting 2]

Adjust the right and left shocks in such a way that both sides of the front wheels will touch down the ground simultaneously when raising the front portion of the model and lowering it down gently. In the case the right and left side wheels land not in the same instant, the steering of each wheel will differ.

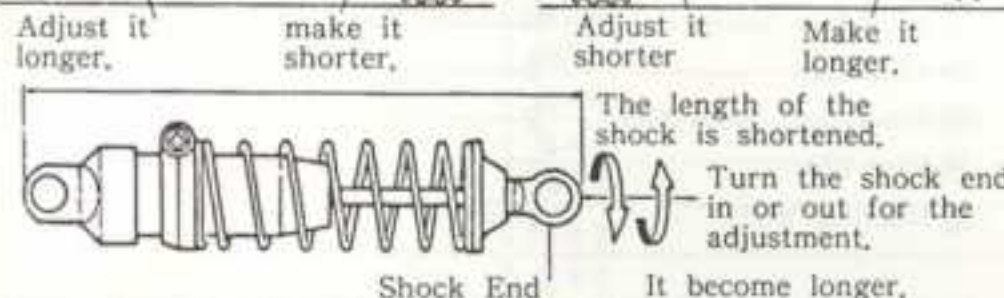
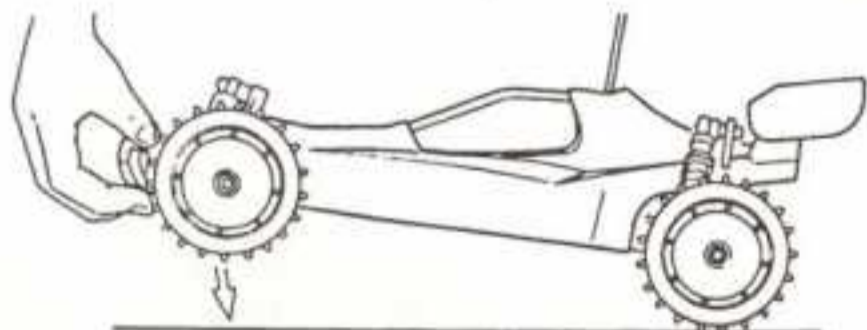

[Correlation between installing Position of Front Upper Rod and Camber Angle]

The installing points A,B, and C on the front shock stay for the upper rod correspond to A',B' and C' which are the maximum camber angle when the front suspension arms swing down to the lowest position.

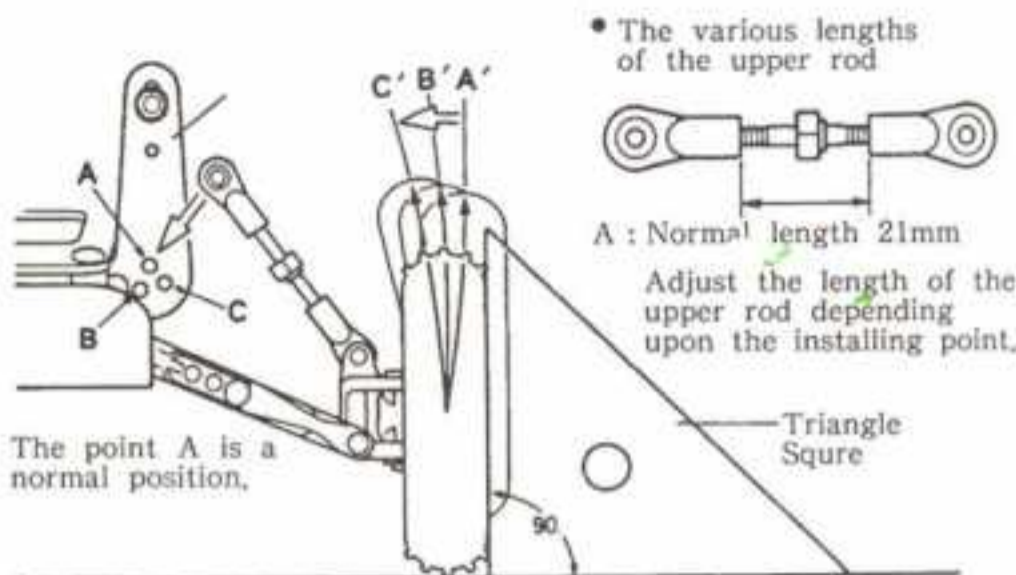

• The various lengths of the upper rod

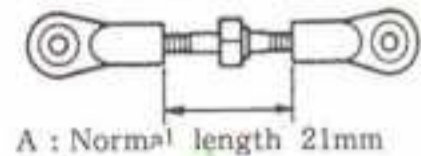

Adjust the length of the upper rod depending upon the installing point.

The point A is a normal position.

[Correlation between installing position of the Rear Upper Rod and Camber Angle]

The installing points A and B on the upper rod plate will result in the positions of the rear camber angle A' and B' when the rear suspension, arms sink the most.

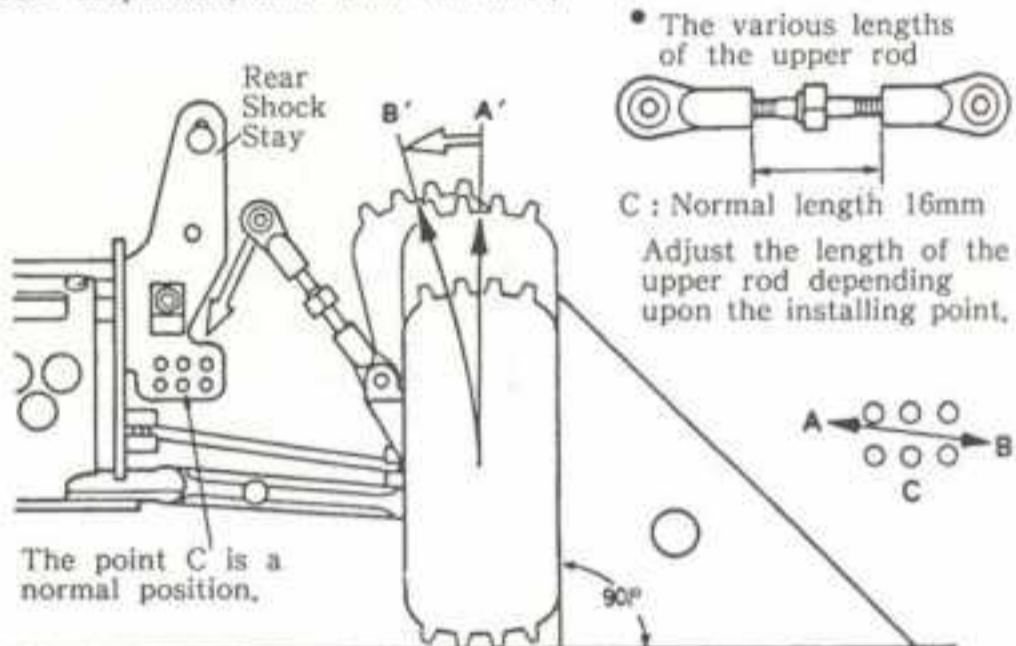

• The various lengths of the upper rod

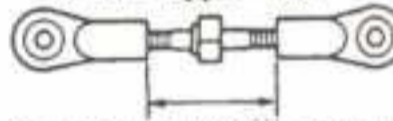

Adjust the length of the upper rod depending upon the installing point.

The point C is a normal position.

[Adjustment of Suspension Spring]

Adjust it with the spring stopper. Leave the clearance of 5mm to 10mm here.

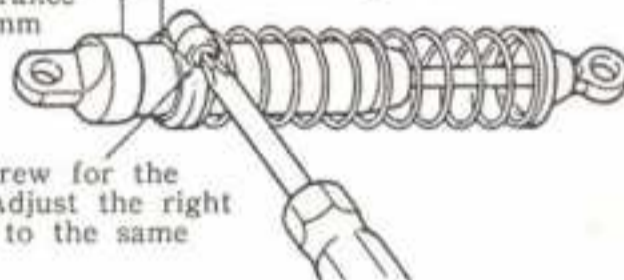

Loosen this screw for the adjustment. (Adjust the right and left sides to the same degree.)

[Adjustment of Shock Oil and Spring]

- Front (With lighter shock oil) → Quicker steering response
- Front (With less spring tension) → Quicker steering response
- Front (With heavier shock oil) → Slower steering response
- Front (With more spring tension) → Slower steering response
- Rear (With lighter shock oil) → More traction
- Rear (With less spring tension) → More traction
- Rear (With heavier shock oil) → less traction
- Rear (With more spring tension) → less traction

[Adjustment of Hardness of Shock Action]

*Take this chart just as general indication.

No.1951 Oil Set	Yellow	Green	Yellow	Red	Green	Red
Piston						
Hardness	← Harder			Softer →		

SETTING GUIDE (2)

[When inserting Shim for Ball Differential adjustment...]

With the torque keeper side facing up, disassemble up to the extent as shown in the diagram.

Stage 1 Remove the torque keeper.

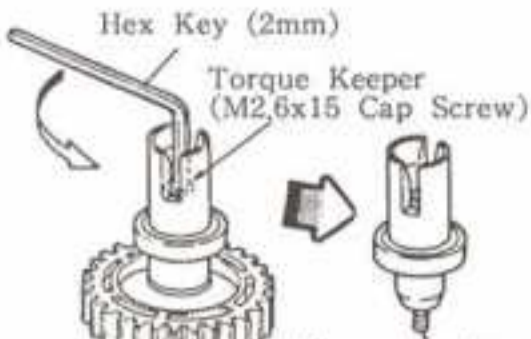

*Leave the torque keeper in this condition. As there are small parts inside, do not pull out.

Depending on the amount of play, add one or two shims in the location shown in the diagram and assemble it back to the original form.

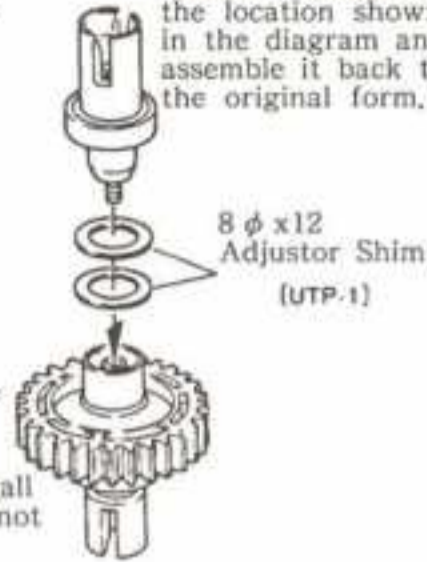

[Relation between Gear Ratio and the Motor]

Pinion Gear (No. of Teeth)	15T	16T	17T	18T	19T	20T	21T	22T	23T	24T	25T	
Gear Ratio	11.1	10.4	9.8	9.2	8.7	8.3	7.9	7.5	7.2	6.9	6.6	
Proper Motor	Le Mans Speed 240T SPA 240WS						Le Mans 240ST, H240S			Le Mans 360GOLD		

MEMO

PARTS LIST

Key #	Parts Name	Q'ty	Key #	Parts Name	Q'ty	Key #	Parts Name	Q'ty	Key #	Parts Name	Q'ty
①	Front Shock Stay	1	④⑩	Gearbox (L)	1	⑦⑨	Rear Suspension Shaft (B)	2	⑩⑩	Center Rod	1
②	Rear Shock Stay	1	④⑪	Gearbox (R)	1	⑩⑪	Stabilizer Ball	2	⑩⑪	Motor Guard joint	1
③	4 φ x 8 Bearing	6	④⑫	Stabilizer Link (L)	2	⑩⑫	Adjust Ball	4	⑩⑫	Body	1
④	5 φ x 10 Bearing	6	④⑬	Stabilizer Link (S)	2	⑩⑬	Sponge Cap	1	⑩⑬	Wing	1
⑤	Center Gear collar	1	④⑭	Stabilizer Stopper	2	⑩⑭	Motor Guard Plate	1	⑩⑭	Front Tire	2
⑥	Motor Guard	1	④⑮	Motor Cord	1	⑩⑮	Servo Saver Spring	1	⑩⑮	Rear Tire	2
⑦	Motor Plate	1	④⑯	Wing Stay	1	⑩⑯	Front Bulk Head	1	⑩⑯	Main Frame	1
⑧	8 φ x 14 Bearing	2	④⑰	Gear Cover Seal	1	⑩⑰	Rear Axle Stopper	1	⑩⑰	Decal	1
⑨	Differential Body	1	④⑱	Double Sided Tape	1	⑩⑱	Rear Bulk Head	1	⑩⑱	E Ring (E3) (Black)	*2
⑩	Differential Shaft (A)	1	④⑲	Strap (S)	2	⑩⑲	Gear Cover	1	⑩⑲	E Ring (E4)	*1
⑪	Differential Shaft (B)	1	④⑳	NiCd Strap	2	⑩⑳	Bumper	1	⑩⑳	Hook Pin	*1
⑫	Pressure Plate	2	④㉑	Antenna Pipe	1	⑩㉑	Front Hub	2	⑩㉑	Body Pin	*6
⑬	8 φ x 10 Collar	1	④㉒	Shock Oil (Green)	1	⑩㉒	Rear Hub	2	⑩㉑	Hex Key (1.5mm)	1
⑭	Torque keeper ^{M2.6x15} Cap Screw	1	④㉓	Screw Cement (Loctite)	1	⑩㉓	Knuckle Arm (L)	1	⑩㉑	Hex Key (2mm)	1
⑮	Tapered Washer	4	④㉔	Silicon Grease	1	⑩㉔	Knuckle Arm (R)	1	⑩㉑	Hex Key (2.5mm)	1
⑯	Differential Ball	10	④㉕	Condensor	1	⑩㉕	Servo Saver (A)	1	⑩㉑	Body Hook	1
⑰	Thrust Ball	8	④㉖	Rear Wheel	2	⑩㉖	Servo Saver (B)	1	⑩㉑	Bind Screw M2.6x6	8
⑱	Thrust Washer	2	④㉗	Front Wheel	2	⑩㉖	Servo Saver (C)	1	⑩㉑	" M3x6	11
⑲	Front Shock Shaft	2	④㉘	Pinion Gear (20T)	1	⑩㉖	Servo Saver (D)	1	⑩㉑	" M3x18	2
⑳	Rear Shock Shaft	2	④㉙	Center Gear Shaft	1	⑩㉖	Servo Saver Collar	2	⑩㉑	" M3x36	1
㉑	Front Shock Case	2	④㉚	Counter Gear Shaft	1	⑩㉖	Gearbox Hatch	1	⑩㉑	" M3x45	2
㉒	Rear Shock Case	2	④㉛	2 φ x 11 Pin	*1	⑩㉖	M3 Plastic Nut	*4	⑩㉑	Round Head Screw M2x10	2
㉓	Front Shock Spring	2	④㉜	Front Wheel Shaft	2	⑩㉖	Servo Stay	*2	⑩㉑	" M3x33	1
㉔	Rear Shock Spring	2	④㉝	Servo Saver Shaft	2	⑩㉖	Shock Collar	4	⑩㉑	Flat Head Screw M2.6x12	6
㉕	Spring Holder	4	④㉞	Wing Stopper	2	⑩㉖	Antenna Post	1	⑩㉑	" M3x6	4
㉖	Shock Cap	4	④㉟	Radio Plate Post	2	⑩㉖	Battery Stopper	2	⑩㉑	" M3x15	12
㉗	Spring Stopper	4	④㊱	3 φ x 32 Adjust Rod	4	⑩㉖	Stopper Post	4	⑩㉑	" M4x8	8
㉘	Shock End	4	④㊲	3 φ x 50 Adjust Rod	2	⑩㉖	Stopper Washer (Thinner one)	2	⑩㉑	" M4x12	4
㉙	E Ring (E2.5)	*16	④㊳	5.8 φ Ball (Black)	6	⑩㉖	Stopper Washer (Thicker one)	2	⑩㉑	Thru Screw M4x8	4
㉚	Final Pinion	1	④㊴	O Ring (P3 • Black)	1	⑩㉖	Ball End (L)	12	⑩㉑	TP Bind Screw M3x8	11
㉛	Center Gear	1	④㊵	Motor Guard Collar	2	⑩㉖	Ball End (S)	1	⑩㉑	TP Round Head Screw M3x18	1
㉜	Counter Gear	1	④㊶	Shock Piston	4	⑩㉖	Front Sus. Shaft (A) (Silver)	2	⑩㉑	Nut M2.6 (3 kinds)	10
㉝	Swing Shaft	2	④㊷	Shock Collar (White)	4	⑩㉖	Front Sus. Shaft (A) (Black)	2	⑩㉑	" M3	8
㉞	Wing Post	2	④㊸	Shock Collar (Black)	4	⑩㉖	Ball Nut	1	⑩㉑	Nylon Nut	4
㉟	Drive Washer	2	④㊹	Pressure Top	4	⑩㉖	5.8 φ Ball (Silver)	10	⑩㉑	Washer M3	2
㊱	Rear Wheel Shaft	2	④㊺	O Ring (P3 • Red)	8	⑩㉖	4.8 φ Ball	2	⑩㉑	" M4	2
㊲	Front Suspension Arm	2	④㊻	C Ring	*4	⑩㉖	Front Sus. Shaft (B)	2	⑩㉑	" φ 8x12	2
㊳	Rear Suspension Arm	2	④㊼	Front Stabilizer	1	⑩㉖	King Pin	2	⑩㉑	Set Screw M3x3	5
㊴	Radio Plate	1	④㊽	Rear Stabilizer	1	⑩㉖	Steering Rod	1	⑩㉑	" M4x4	1

PURCHASABLE PARTS FOR YOUR KIT

You can purchase replacement and optional parts for your kit. All of the part identified by key number are usually not available singularly, but we offer these parts in convenient parts "packs" which can be purchased separately. To figure out which parts pack you need, find the key number for that part with the manual.

Then consult out parts pack guide below. When referring to the parts you need, always use the Parts Pack Number. For example, if you need a Center Gear Shaft (Key #59) ask your dealer for Kyosho Parts Pack UM-5 (Gear Shaft Set).

OT-6	Swing Shaft	⊗×2
OT-18	Rear Shaft	⊗×2
OT-19	Drive Washer	⊗×4
OT-29	O Ring	⊗×10
OT-32	5,8 φ Ball	⊗×10
OT-33	Ball Nut (M2,6)	⊗×10
OT-38	Silicon Grease	⊗×1
OT-39	E Ring (E2,5)	⊗×10
OT-65	Wing Stay Set	⊗×1 ⊗⊗×2
OT-66	Low Profile Tire	⊗×2
OT-76	Hard Final Pinion	⊗×1
OT-79	Motor Cord Set	⊗×1 Set
OT-101	5,8 φ Ball (Black2,6Hole)	⊗×10
OT-107	Wing	⊗×1
OTW-9	Plastic Parts Set	⊗⊗⊗×2 ⊗×4
MA-17	Wheel Set	⊗×4
UM-1	Gear Set	⊗×1
UM-3	Gearbox	⊗⊗×1
UM-4	Motor Plate	⊗×1
UM-5	Gear Shaft Set	⊗⊗×1 ⊗×2
UM-7	Suspension Shaft Set	⊗⊗⊗⊗×2
UM-8	Front Shaft Set	⊗⊗×2
UM-9	Rod Set	⊗⊗×1 ⊗×2
UM-11	Up Light Set	⊗⊗×1 ⊗⊗×2
UM-12	Bulk Head Set	⊗⊗⊗⊗⊗×1
UM-13	Suspension Arm Set	⊗⊗×2
UM-14	Servo Saver Set	⊗⊗⊗⊗⊗⊗⊗×1 ⊗×2 ⊗⊗×4 ⊗×6
UM-21	Front Bumper	⊗×1
UM-26	Special Shock Stay	⊗⊗×1
UM-28	Motor Guard	⊗⊗⊗×1 ⊗×2
UM-29	Stabilizer Set	⊗⊗×1 ⊗⊗⊗⊗⊗⊗×2 ⊗×4
UM-34	Body (Ultima Pro)	⊗×1
UM-37	Chassis	⊗×1
UM-38	Upper Plate	⊗×1
UM-39	Front Wheel Set (Yellow)	⊗×2
UM-40	Decal (Ultima Pro)	⊗×1
UM-41	Screw Set (Ultima Pro)	Screw, Nut & Hex Key Set
W-0109	Ball Diff.	⊗⊗⊗⊗⊗⊗×1 ⊗⊗×2 ⊗×4 ⊗×8 ⊗×10
W-0110	Special Spur Gear	⊗×1
W-5005	Special Rod Set	⊗×2 ⊗⊗×4 ⊗×8 ⊗×12
W-5001	Pressure Shock (S)	⊗⊗⊗⊗⊗⊗⊗⊗⊗⊗×2 ⊗⊗⊗×4
W-5002	Pressure Shock (L)	⊗⊗⊗⊗⊗⊗⊗⊗⊗⊗×2 ⊗⊗⊗×4
W-5074	Front Tire S-H (Pin Spike, Hard Compound)	⊗×2
1840	Double Sided Tape	⊗×1
EP-22	Hook Pin	⊗×5
EF-37	Strap (S)	⊗×6
EF-39	NiCd Strap	⊗×6
SD-79	Antenna Pipe	⊗×5
CB-72	E Ring (E3)	⊗×4
KC-20	E Ring (E4)	⊗×4
1889	Body Pin	⊗×5
1901	Ball Bearing (5 φ x10)	⊗×2
1903	" (4 φ x8)	⊗×2
1911	Ball Bearing (8 φ x14)	⊗×2
1878	Screw Cement (Loctite)	⊗
1974	Bearing Set (For Ultima)	⊗×1 ⊗×2 ⊗⊗×6
UM-42	Saver Shaft Set	⊗⊗×2
UM-43	Servo Saver Strong Ring	⊗×2
	OPTIONAL PARTS	
UM-17	Wheel Set	Front • Rear x 2
OT-90	Wheel	One piece type 4pcs.
FD-2	Wheel	"
EF-103	Racing Wire	4 φ Silicon Cord
LM-15	Motor Cooling Plate	For Lemans
RK-15	Low Profile Tire	Rear Tire x 2
1863	Sponsor Sticker	Decal Sponsor Mark
SC-90	Front Tire	
SC-26	"	
1872	Sponge Tire (A)	
1883	Frontier Hobby Oil	30cc.
1953	Silicon Oil (S)	Viscosity 100SC,200SC x 1 (Same as 1951S)
1954	" (M)	Viscosity 300SC,400SC x 1 (Same as 1951M)
1955	" (H)	Viscosity 500SC,600SC x 1 (Same as 1951H)
1951	Shock Oil (S,M,H)	Soft, Midium, Hard
LM-18		⊗
WBD-1	Ball Diff. Shaft Plate Set	⊗⊗⊗×1 ⊗×2
WBD-2	Ball Diff. Ball Set	⊗⊗×1 ⊗×2 ⊗×10 ⊗⊗×12
WBD-3	Ball Differential (Body)	⊗×1 Others x 4
W-5003	Adjustable Shock (S)	
W-5004	Adjustable Shock (L)	
W-5021	Low profile Wheel	Silver Plate x 2
W-5022	Narrow Wheel	"
W-5023	Low Profile Wheel (Yellow)	
W-5024	Narrow Wheel (Yellow)	
OT-121	Narrow Wheel	
1875	Front Tire (A)	
W-5031	Low Profile Tire (Hard)	2pcs.
W-5032	Low Profile Tire (Soft)	2pcs.
W-5033	Narrow Wheel (Pin Typ)	2pcs.
W-5034	Narrow Wheel (Hard)	2pcs.
W-5071	Front Tire M-S	
W-5072	" M-H	
W-5073	" S-S	Pin Spike Soft Compound 2pcs.
W-5075	Narrow Wheel SS-M	
W-5076	" MH-M	Multi Spike x 2
W-5077	Low Profile Wheel SS-M	
W-5078	" MH-M	Multi Spike x 2
W-5085	Hard Pinion Gear (15T-25T)	Hard Aluminum
W-5095		
W-0111	Special Counter Gear	⊗ Strong Type
W-5061	Universal Swing Shaft	⊗⊗

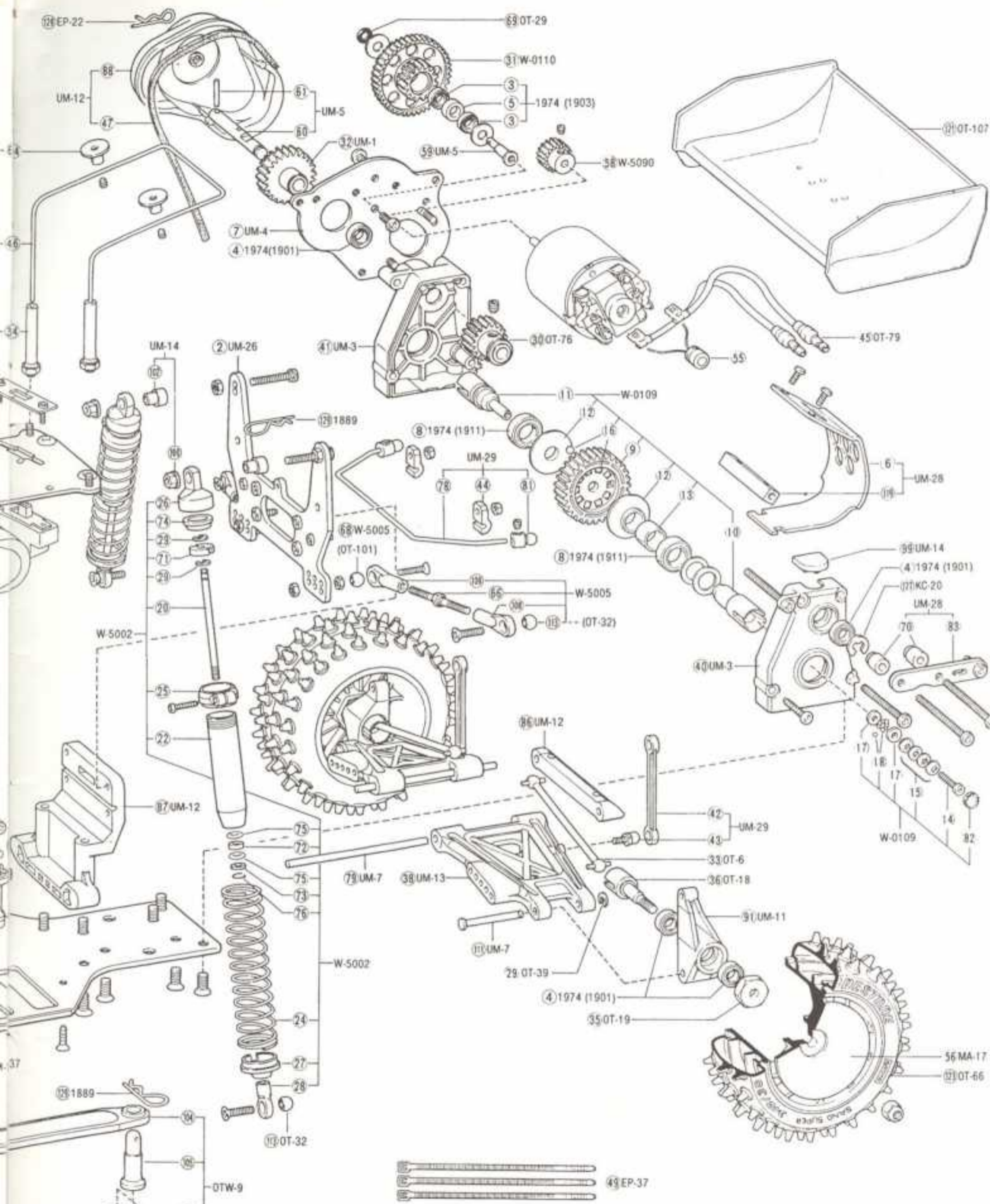

- 49 EP-37
- 33 1878
- 54 OT-38

—The Super Hobby—
KYOSHO
THE FINEST RADIO CONTROL MODELS
 KYOSHO CORPORATION

The Super Hobby



This products is not to be sold in the United States. If you have purchased this product in the United States, please contact Tom Miller at Kyosho U.S.A, phone number (217) 398-3630.

PRINTED IN JAPAN
AFCM3T