

RADIO CONTROLLED ELECTRIC POWERED SPECIAL RACING BUGGY

OFF-ROAD RACER

TURBO ULTIMA

THE HIGHEST PERFORMANCE 2WD BUGGY ON THE TRACK.
SUPER LIGHT WEIGHT FOR QUICK ACCELERATION.
SUPERB LONG-TRAVEL SUSPENSION FOR EXCELLENT HANDLING ON ANY SURFACE.
INDIPENDENT SUSPENSION ON ALL FOR WHEELS WITH PLATINUM OIL-FILLED SHOCK
ABSORBERS AND STABILIZER BARS.
NEW SHIELDED HEAVY DUTY ROTALY SPEED CONTROLLER.
DOUBLE WISHBONE SUSPENSION DESIGN FOR OPTIMUM WHEEL POSITIONING.
RACE-TESTED GEOMETRY.
BALL DIFFERENTIAL FOR OPTIMUM POWER DISTRIBUTION.
RIGID, LIGHT ALUMINUM-ALLOY CHASSIS.
POWERFUL LeMANS 240ST MOTOR INCLUDED IN KIT.
FOURTEEN BALL BEARING TO REDUCE FRICTION.
HIGH-STRENGTH, HIGH-QUALITY PARTS FOR LONG SERVICE LIFE.

1:10 SCALE

BATTERY: 7.2V-11200mAh NiCd

RADIO: 2 channel
(NOT INCLUDED)



KYOSHO
THE FINEST RADIO CONTROL MODELS

◀ KIT No.3116 ▶

BEFORE ASSEMBLY

○ Read the instruction carefully.

You can assemble the kit more easily if you have grasped the general idea of steps and structure beforehand by reading it through to the end.

○ Check the parts in the kit.

Check to see if all the parts are correctly bagged as they are listed in the "List of Bagged Parts". Your thorough understanding of the assembly will enable you to build the kit without any difficulty. Check the components in the kit prior to your starting of the assembly.



Any claims for replacements or refunds for the model in the process of assembly will not be accepted.

○ Learn the marks described in the instruction.

SW-CEMENT ... Places to put some locktite.

It will prevent the screws and nuts get loosen by vibration while running.

Point where grease should applied.

GREASE ...

(It will reduce friction and assure smooth movement.)



Steps where your particular attention is required.

○ Be well aware of the different types of screws.

1 The difference between the TP screw (short form of self-tapping screw) and the ordinary screw is ...

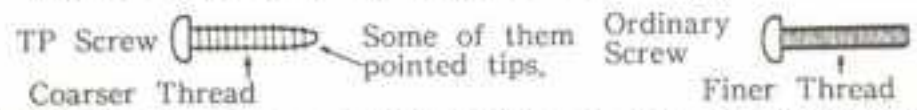

2 The kinds of screws which will be used in this instruction.

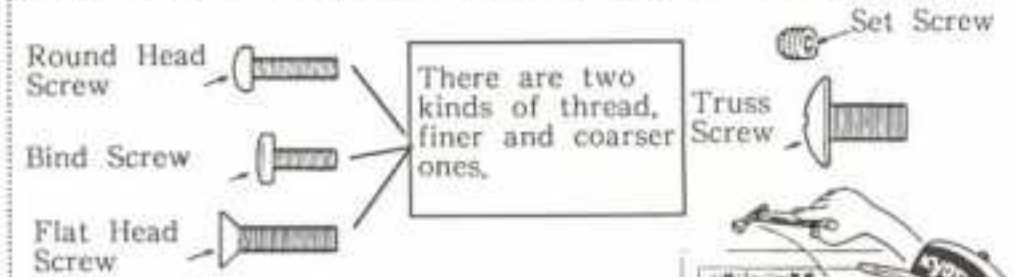

○ Pick up the correct parts and screw.

Compare the shape and size of small parts, such as screws, nuts, and washers with the attached sheet of "List of Small Parts."



Check up small parts with the list.

○ Be sure about the location and direction of parts to install.

Double-check the location and orientation of parts with the illustration before installation. When necessary, assemble the parts themselves tentatively before proceeding to the next step.

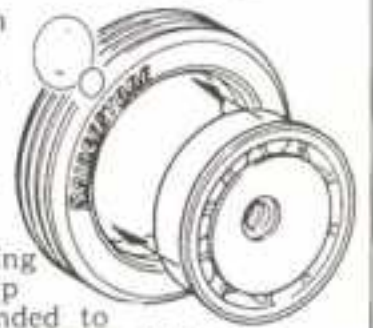

○ Do not tighten the self-tapping screw too tight.

Do not use excessive force when tightening the self-tapping screws, or you may strip the thread in the plastic. It is recommended to stop tightening it when the thread part on the screw goes into the plastic part and you feel some resistance from the tightening.

Over tighten may strip the thread in the plastic.

Good

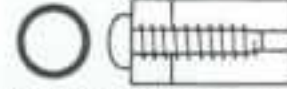

Wrong

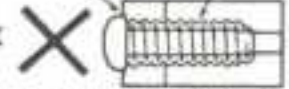

THINGS NEED BESIDES THE KIT

[2 Channel Radio System]



This model is designed for being controlled by a BEC type radio only. Get a radio with a mark as shown at left.

Two types of radio control set are on the market, the stick type and the steering wheel type. Choose whichever you like.

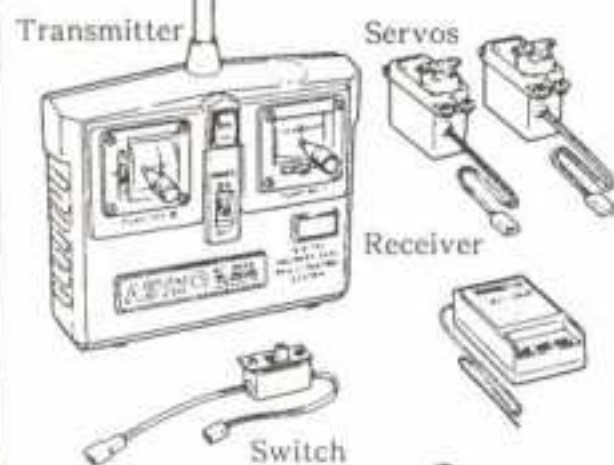

[Battery for Radio System]

For Transmitter ... 8 pcs.



[NiCd Battery]

"Turbo Ultima" is designed to use a rechargeable 7.2V NiCd Battery pack.

7.2V Racing Battery and 7.2V Sprint Battery are ideal for the purpose.

7.2V Sprint Battery SCR 7.2V Racing Battery

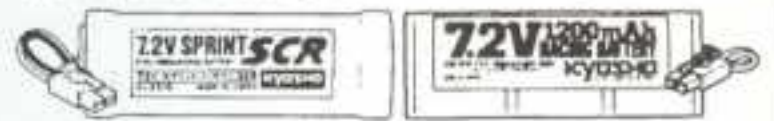

[Motor]

This model kit includes the Le Mans 240ST motor, as a standardized item but the following motors are also optimum to mount:

- W-1011 SPA MOTOR 240WS,
- #1924 LE MANS 240SB
- #1926 LE MANS SPORTS H-240S.



[Charger for NiCd Battery]

The Kyosho's NiCd battery is of high performance. If it is charged correctly, it will operate for a considerable period of time.

Use one of the Chargers listed below which suits your need.

Model	Name	Time	Rate %	Features
No.2221	Super NiCd Charger (AC100V)	14 to 16 (hrs.)	100 %	For beginners
No.2326	7.2V Power Charger (DC12V)	10 (min.)	about 70 %	For beginners Built-in timer
No.1849	Multi Charger II (DC12V)	20 (min.)	100 %	Timer, Ammeter built in
No.1845	Lambda Quick Charger (DC12V)	about 20 (min.)	100%	Trickle charging Automatic cut-off at peak of charge
No.2232	Super NiCd AC Rapid Charger	about 40 (min.)	about 80%	Chargeable from Household Outlet, Electronic Timer built in.

[Tools Required] A Hex Key, Grease and SW-cement are included in the kit.

Philips Screw Driver

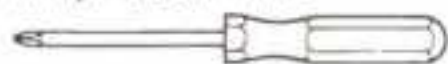

Box Driver (for M3, M4 Nut)



Sharp Hobby Knife



Needle Nose Plier



Round Cutter



Sander



Awl



Wire Cutter



Instant Glue



Polyca Paint



Brush



Micron Line Tape



1 INSTALLATION OF COUNTER GEAR

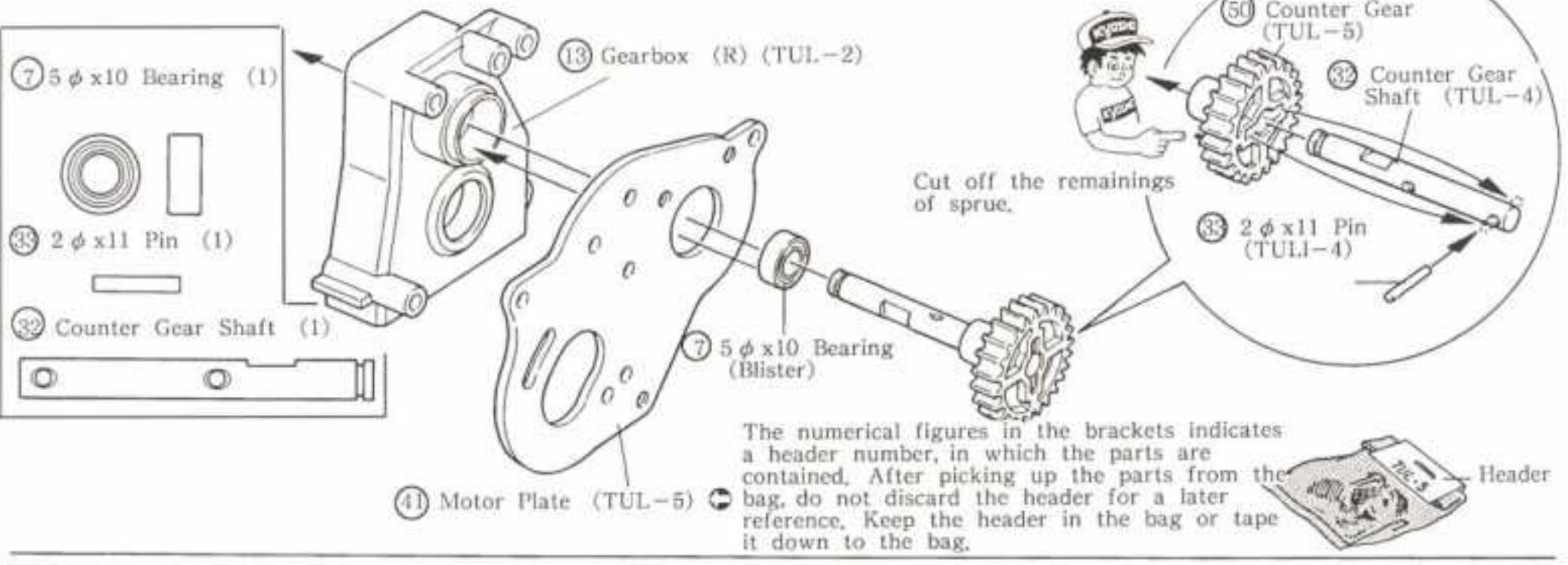

2 INSTALLATION OF FINAL PINION GEAR

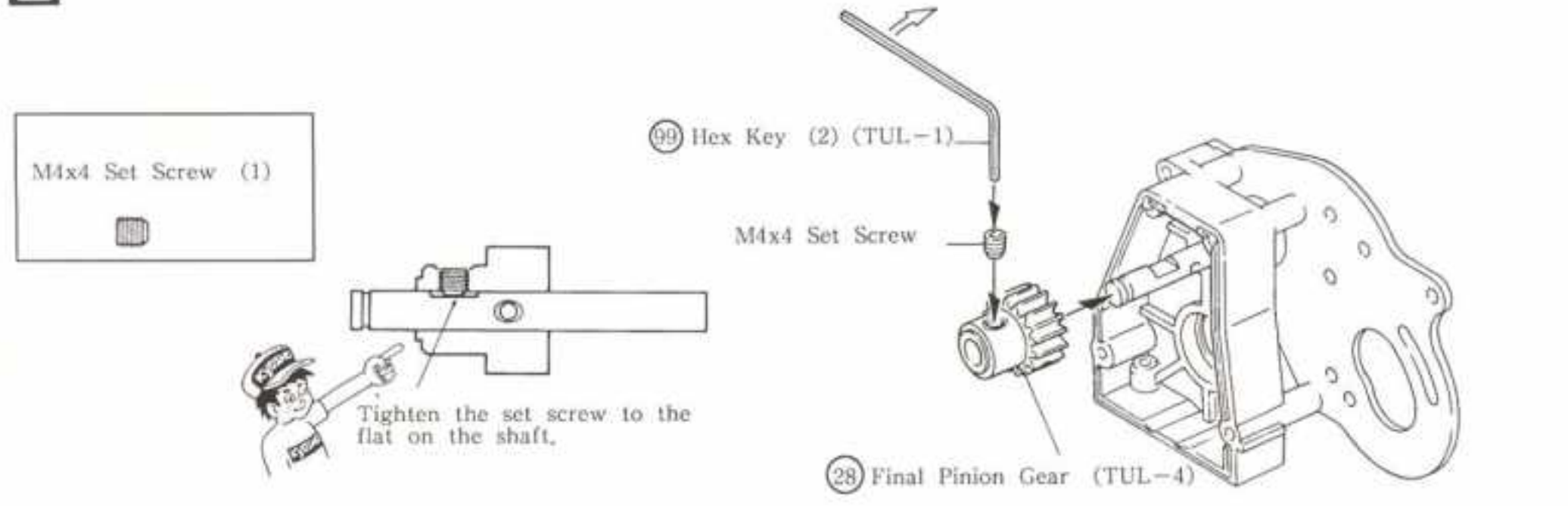

3 ASSEMBLY OF GEARBOX

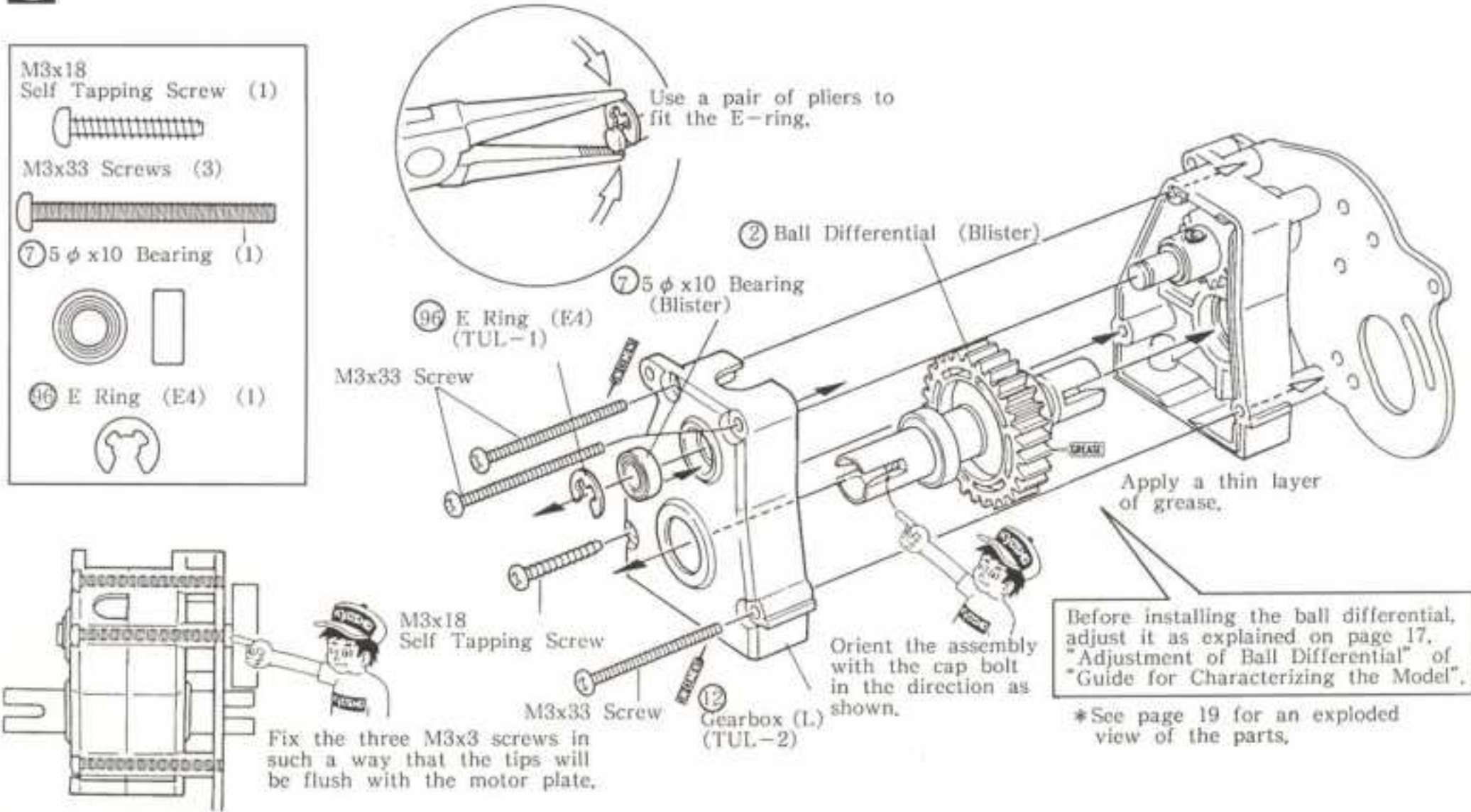

4 INSTALLATION OF REAR SHOCK STAY

Step 1

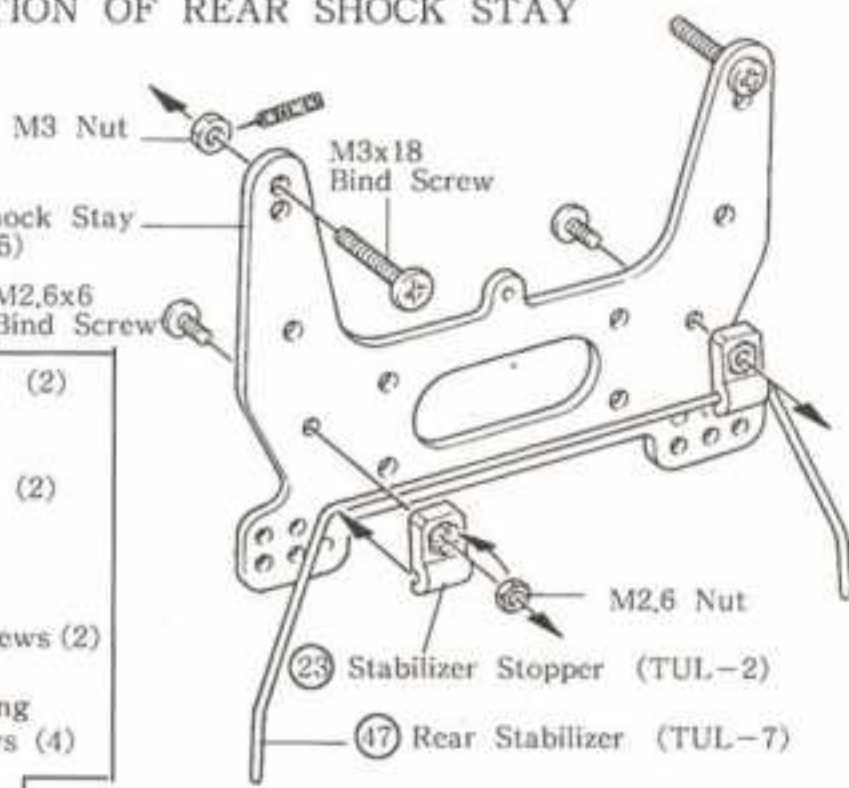

- M2,6x6 Bind Screws (2)
- M3x18 Bind Screws (2)
- M2,6x15 Flat Head Screws (2)
- 3x8 Bind Self Tapping Screws (4)
- M3 Nuts (2)
- M2,6 Nuts (6)
- ⑩ 5,8 φ Balls (Black Color) (2)
- ⑧ 5,8 φ Balls (Silver Color) (2)

Step 2 Assemble two upper rods, right and left, fitting the ball ends referring the actual sized drawing.

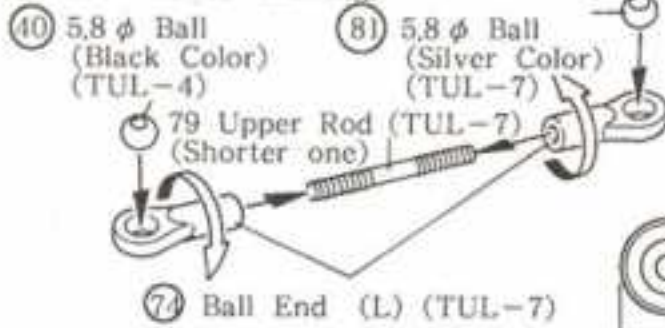

Step 3

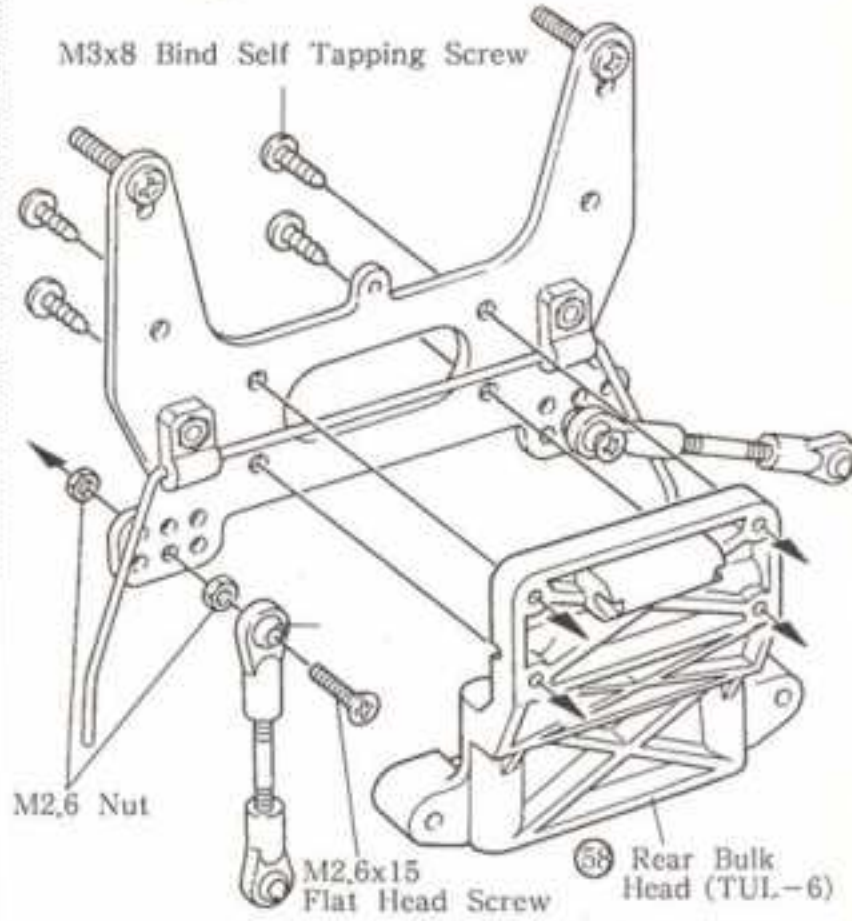

Bolt the upper rod through a center hole in the bottom law.

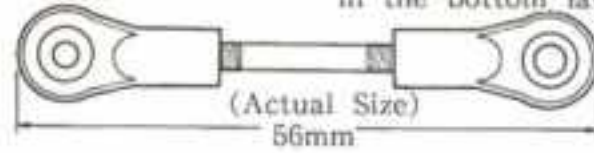

5 INSTALLATION OF GEARBOX

Step 1

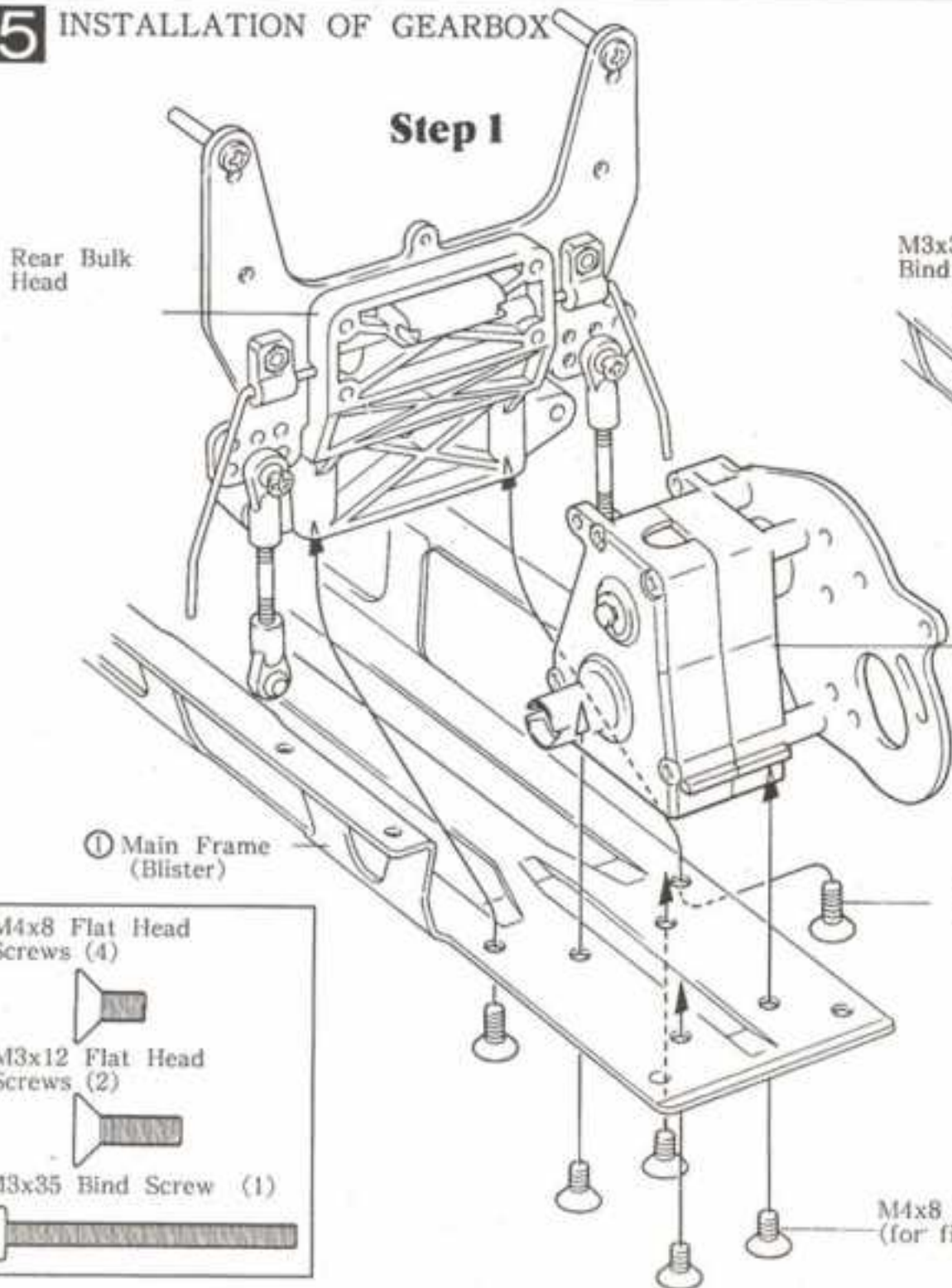

- M4x8 Flat Head Screws (4)
- M3x12 Flat Head Screws (2)
- M3x35 Bind Screw (1)

Step 2

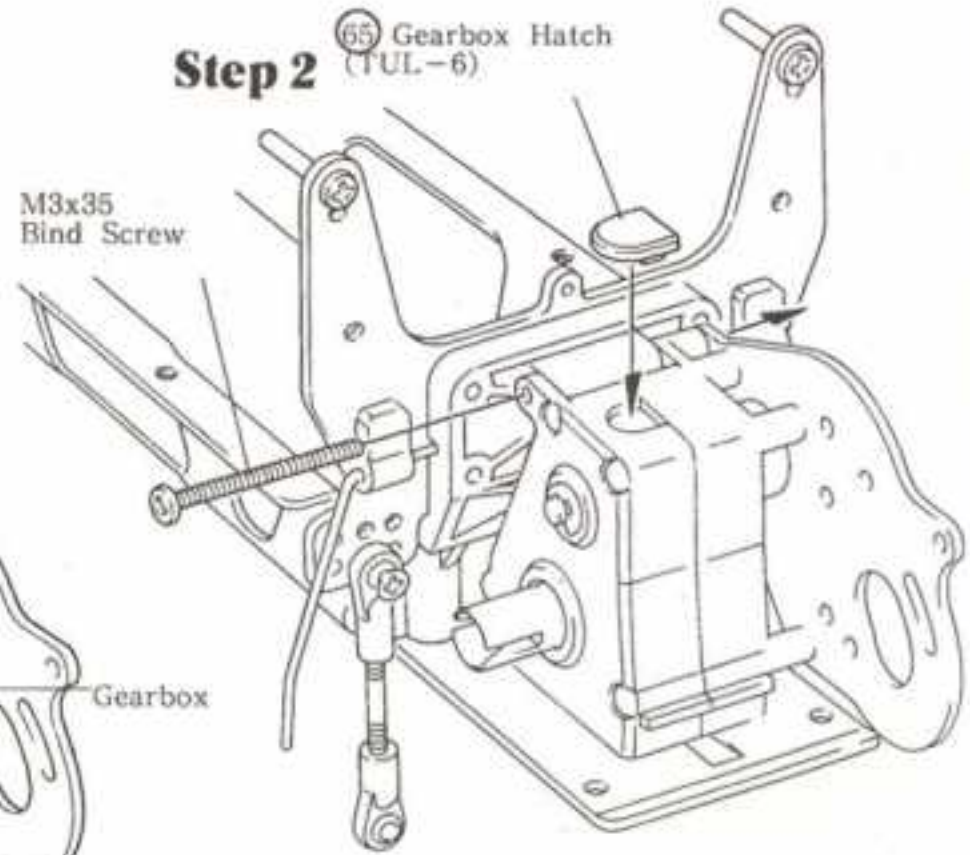

M4x12 Flat Head Screws (2) (for fixing the bulk head)

Fit six flat headed screws temporarily.



M4x8 Flat Head Screw (for fixing the gearbox)

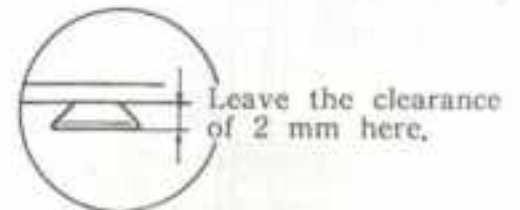

Leave the clearance of 2 mm here.

6 INSTALLATION OF REAR HUB

⑦ 5 φ x10 Bearings (4)



⑤1 Stabilizer Balls (2)



⑦7 Suspension Shafts (A) (2)

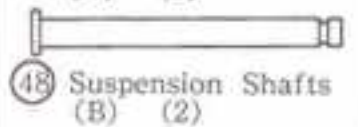

④8 Suspension Shafts (B) (2)

⑨4 E Rings (E2.5) (2)



⑥4 Rear Hub (TUL-6)

③ Universal Swing Shaft (Blister)

④8 Suspension Shaft (B) (TUL-5)

⑥5 Rear Suspension Arm (TUL-6)

Step 1

⑦ 5 φ x10 Bearing (Blister)

Step 2

⑦7 Suspension Shaft (A) (Black Color) (TUL-7)

LEFT

⑤1 Stabilizer Ball (TUL-5)

⑨4 E-ring (E2.5) (TUL-1)

RIGHT

7 INSTALLATION OF REAR SUSPENSION ARM

3x12 Flat Head Screws (2)



M4x8 Flat Head Screws (2)



M3x12 Flat Head Screw



LEFT

RIGHT

M4x8 Flat Head Screw

⑥7 Rear Axle Stopper (TUL-6)

After finishing the work of this step, tighten firmly the six screws which have been left tightened loosely in step 5 "Installation of Gearbox"

8 FILLING SHOCK WITH OIL

⑧1 5.8 φ Balls (Silver Color) (4)



[Disassembly of Shock] Disassemble the four shocks, which are of assembled form in the kit, to the state as shown at right.

Step 1 Compress the spring and remove the stopper (B).

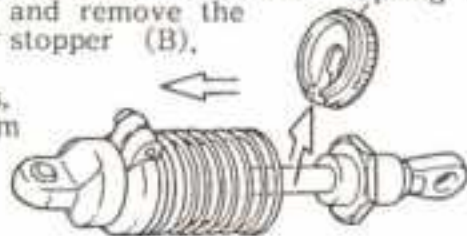

Step 2 Take off the spring and the cap.

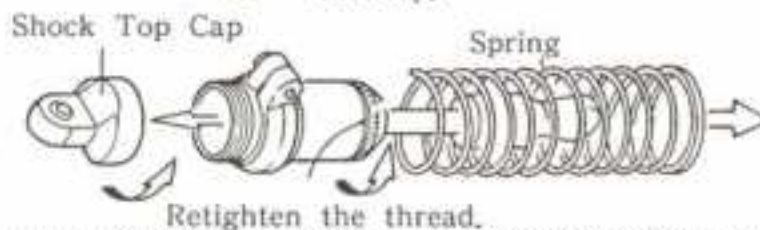

Retighten the thread.

Step 3

[Pouring Oil] Place the piston to the bottom and fill the oil slowly.

Fill the cylinder with oil to the level of over the brim as shown.

⑨3 Shock Oil (TUL-2) Be careful not leave any air bubble in the oil.

Move the piston up and down slowly to get rid of bubbles.

Step 4

Tighten the cap firmly so that the oil will not leak.

⑧1 5.8 φ Ball (Silver Color) (TUL-7)

Step 5

Fit the spring stopper (B) by pressing down the spring.

Spring Stopper (B)

Less tension of the shock.

[Adjustment of damping Ratio] You can characterize your model car by changing the ratio.

Depending upon the clearance here, the damping ratio will vary.

Valve

More tension.

In order to turn the spring stopper (B), hold the shock end here.

12 INSTALLATION OF FRONT SUSPENSION ARM

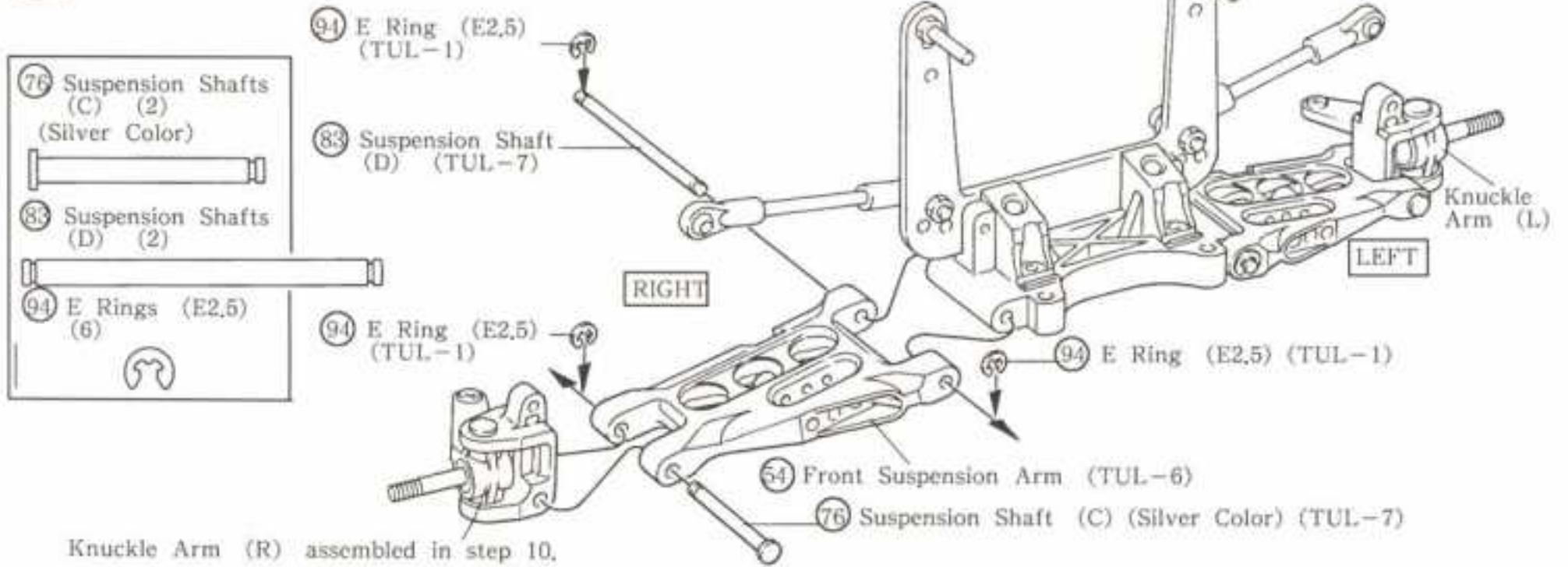

13 INSTALLATION OF FRONT STABILIZER

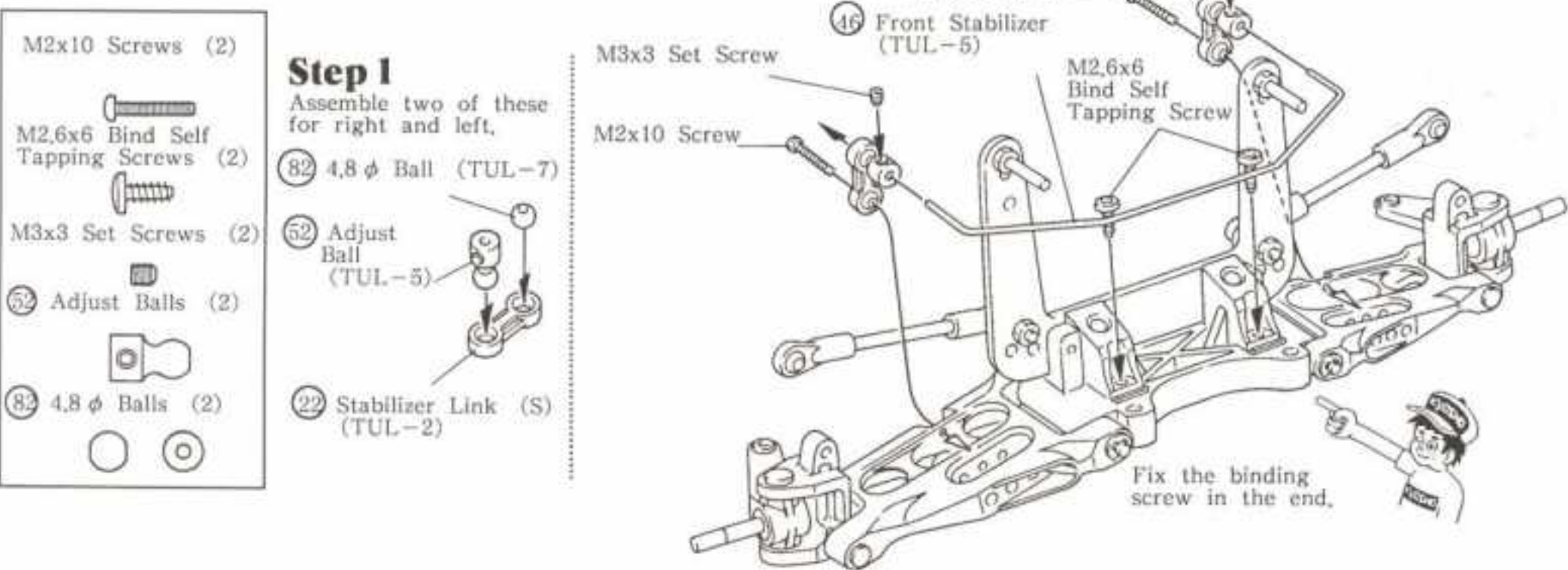

14 INSTALLATION OF FRONT BULK HEAD

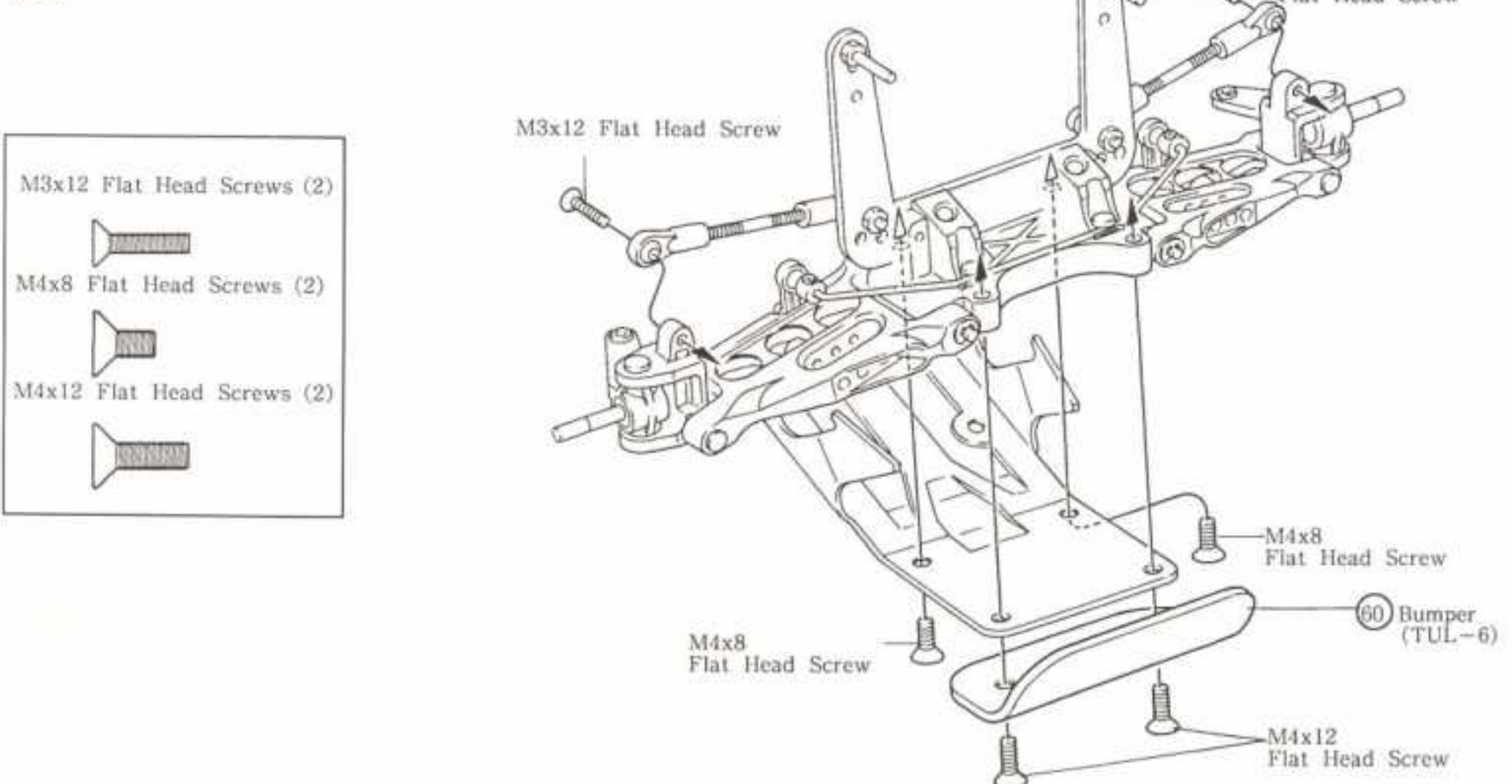

15 INSTALLATION OF FRONT SHOCK

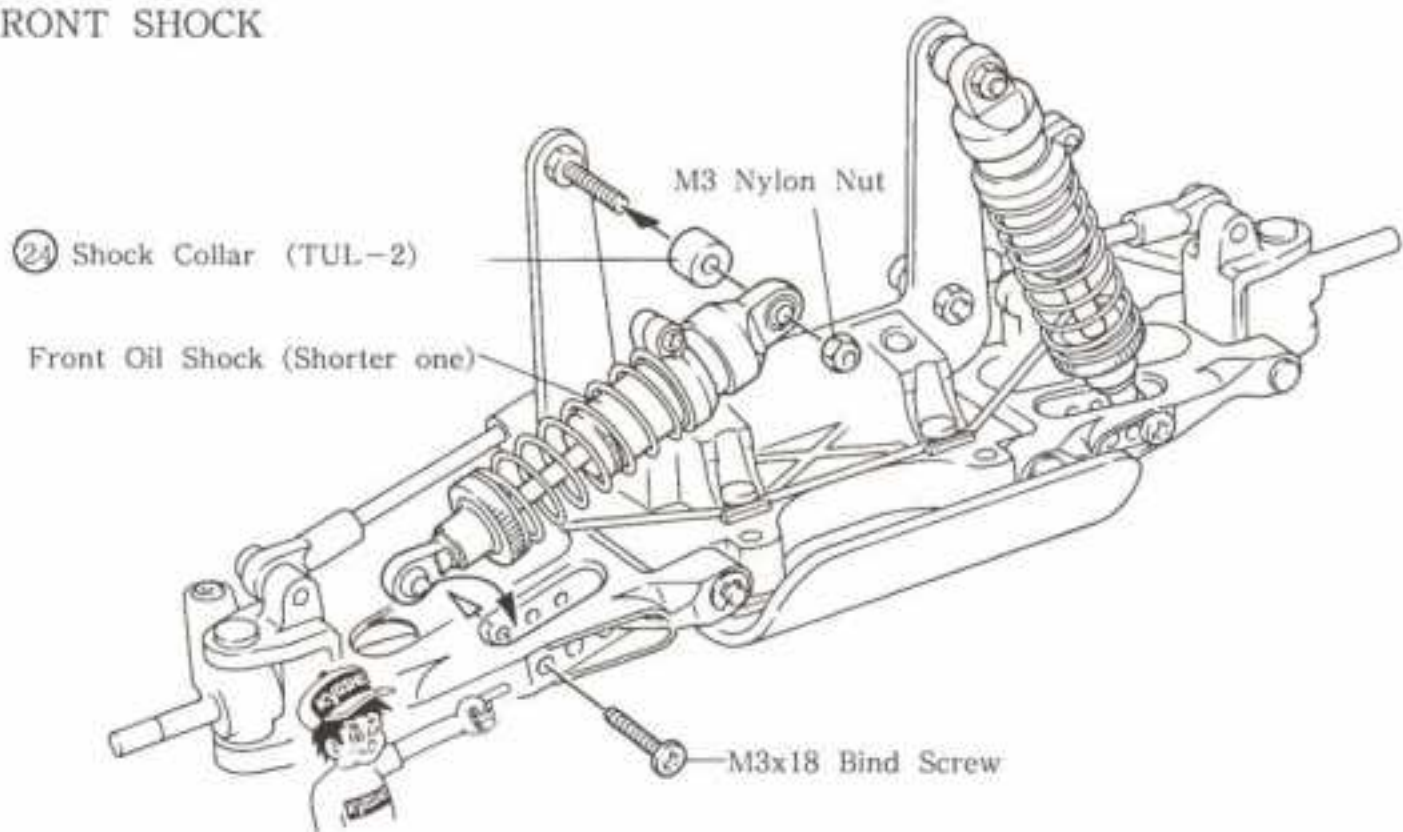
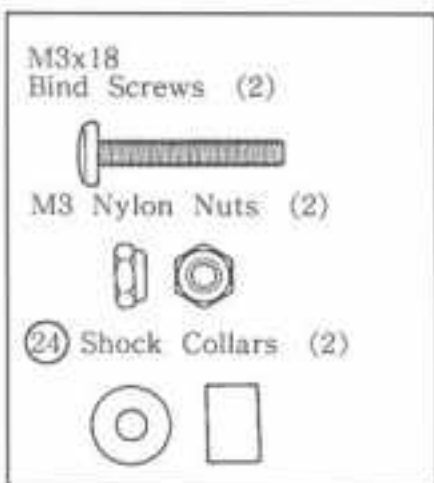

16 ASSEMBLY OF SERVO SAVER

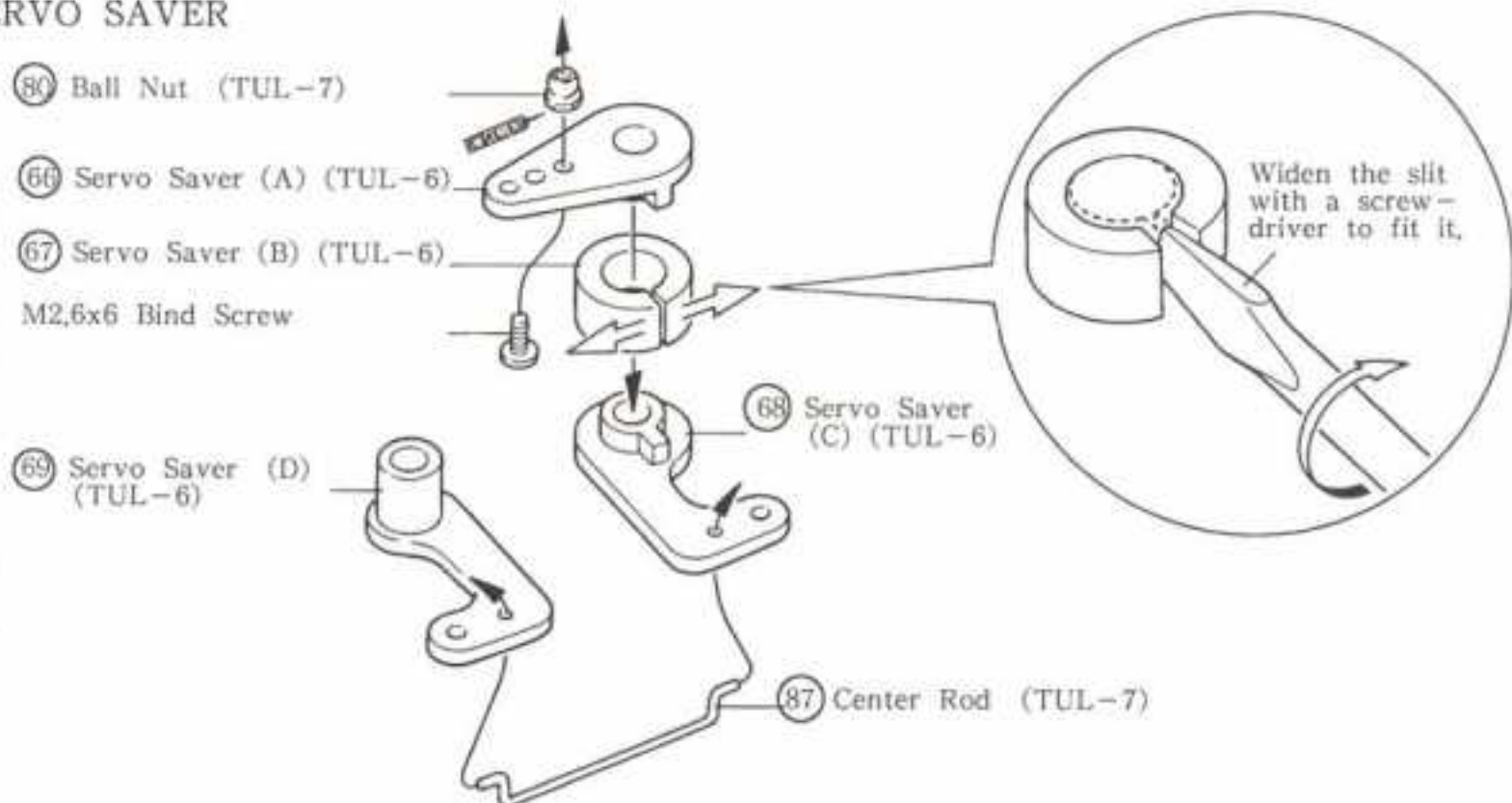
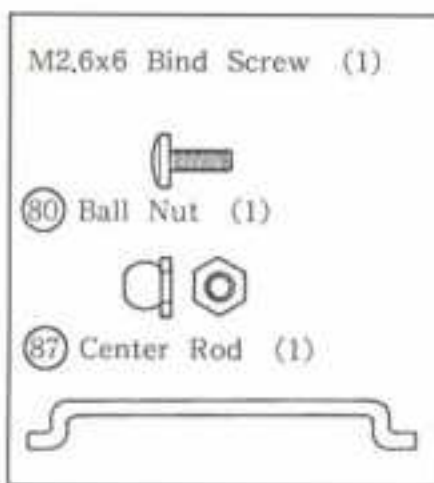

17 INSTALLATION OF SERVO SAVER

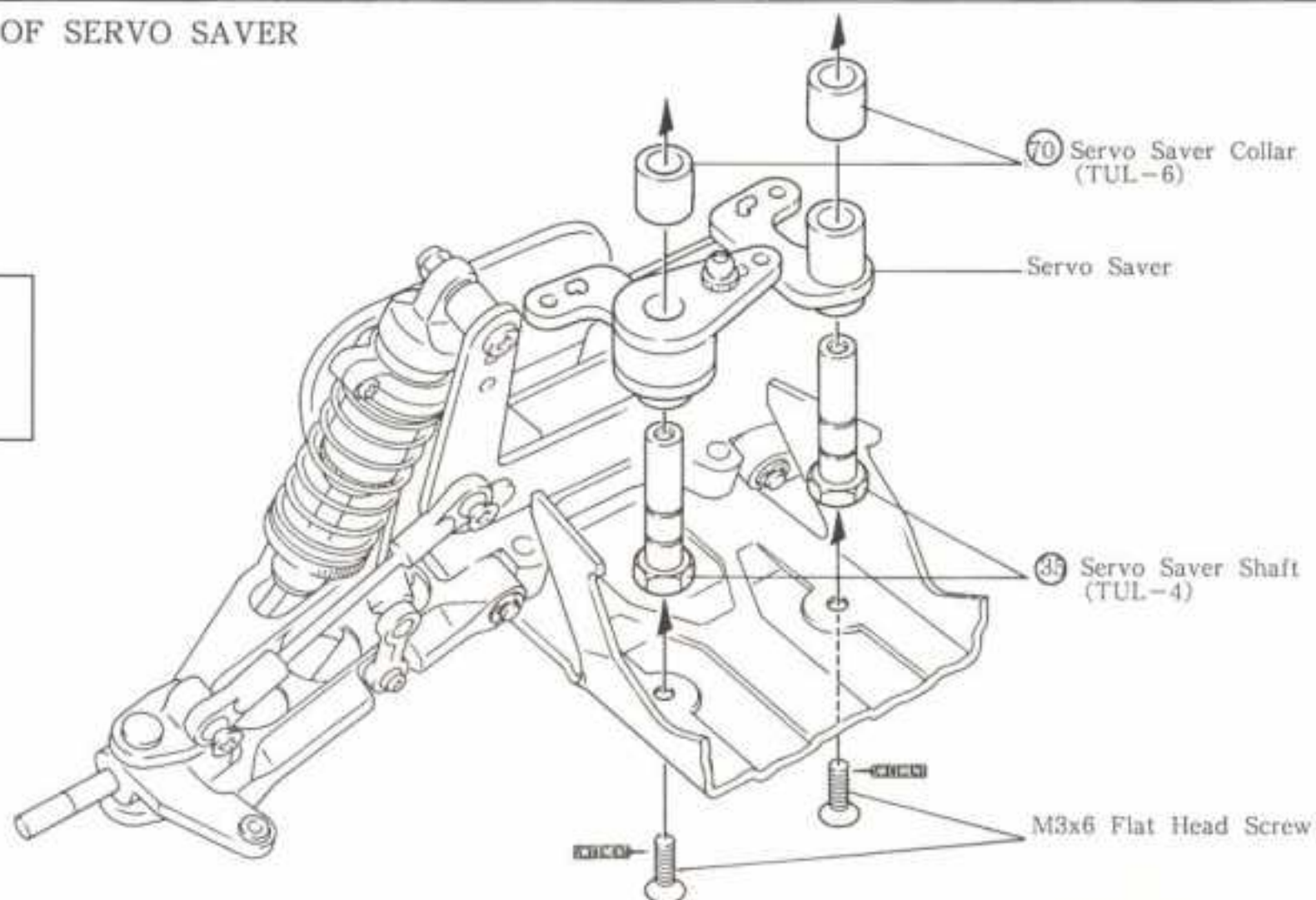
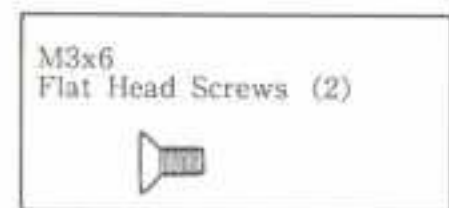

18 INSTALLATION OF TIE ROD

M2,6X15 Flat Head Screws (4)



M2,6 Nuts (4)



⑩ 5.8 φ Balls (Black Color) (4)

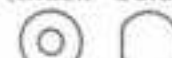

Step 1

Screw in ball ends to two each of the tie rod, right and left referring to the actual size drawing.

⑩ 5.8 φ Ball (Black Color) (TUL-4)

⑦④ Ball End (L) (TUL-7)

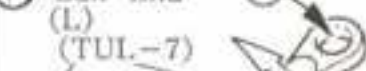

⑩ 5.8 φ Ball (Black Color) (TUL-4)



⑦④ Tie Rod (TUL-7)

Step 2

M2,6x15 Flat Head Screw

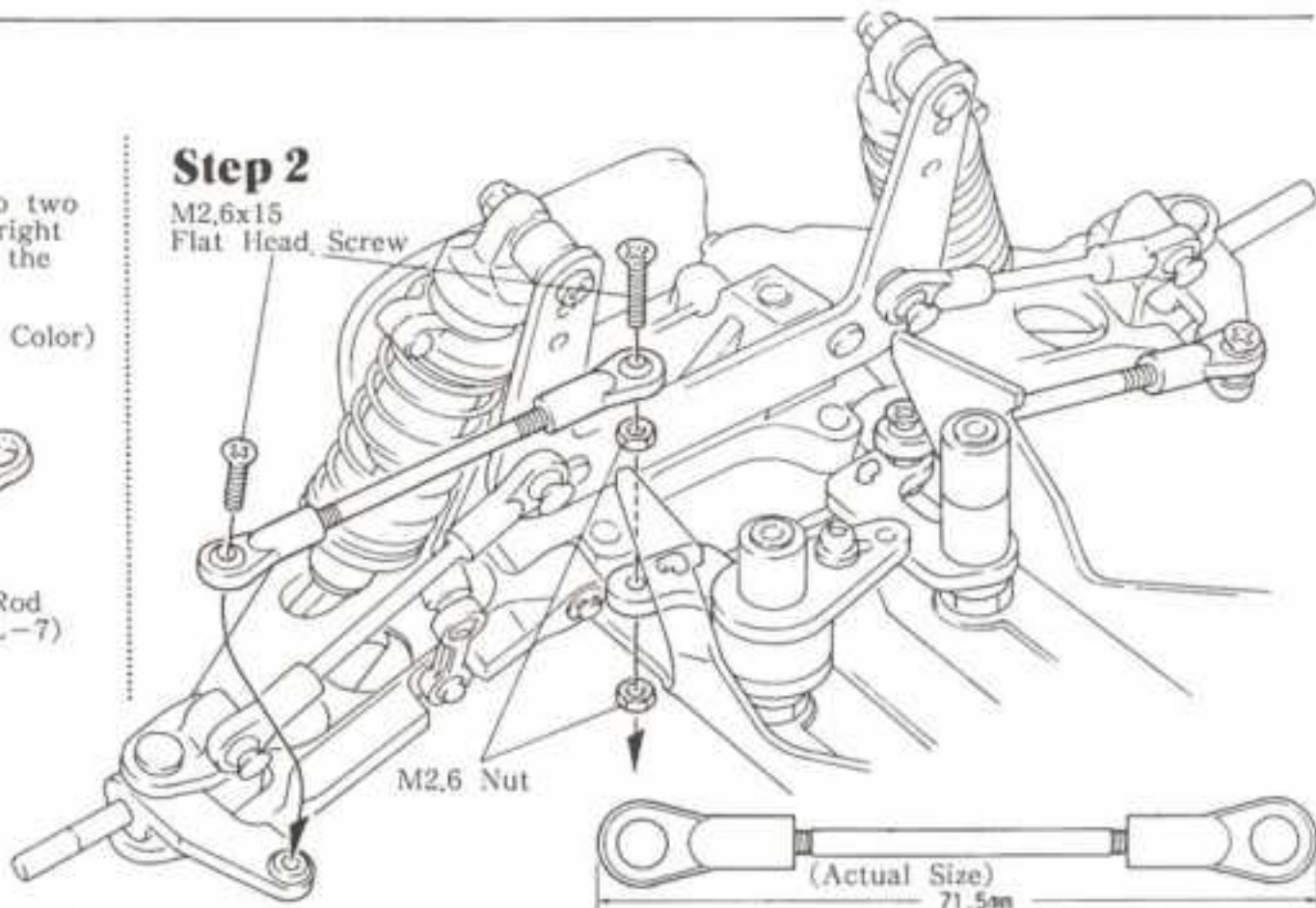

M2,6 Nut

(Actual Size)
71.5mm

19 HOW TO CHECK RADIO SYSTEM

Check the radio control system by operating components in order of the numerical figures.



This model car is designed to be controlled by the BEC type radio only.

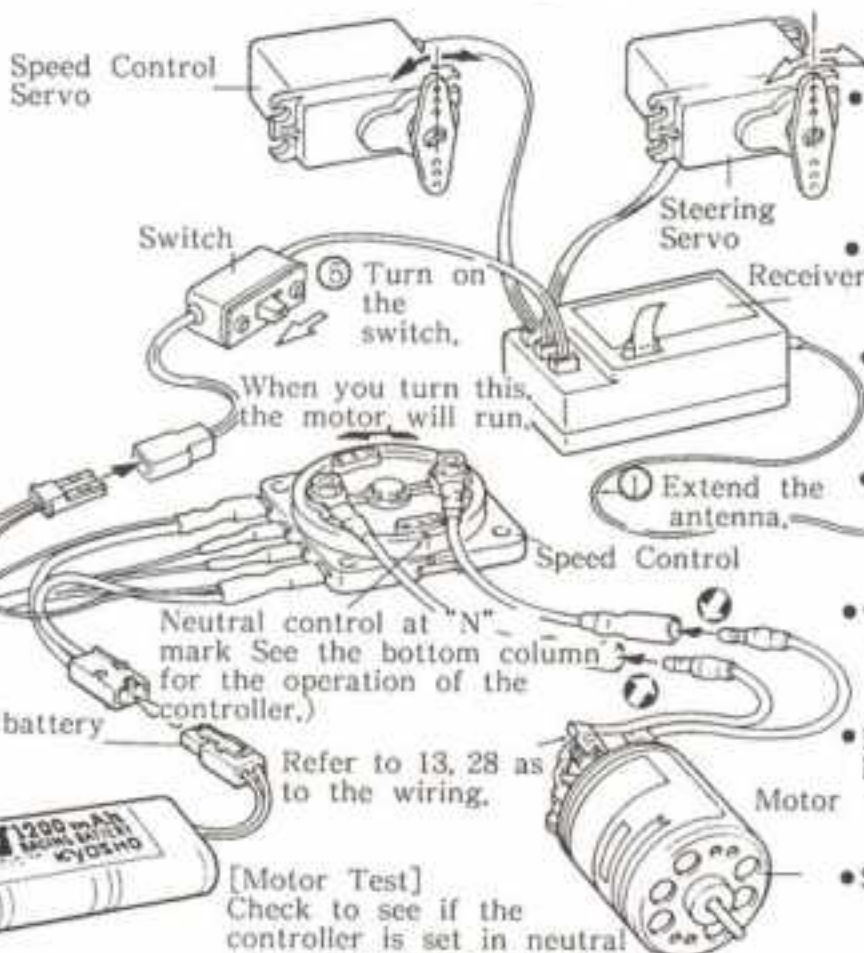
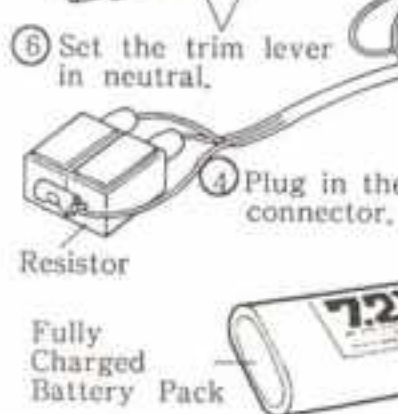
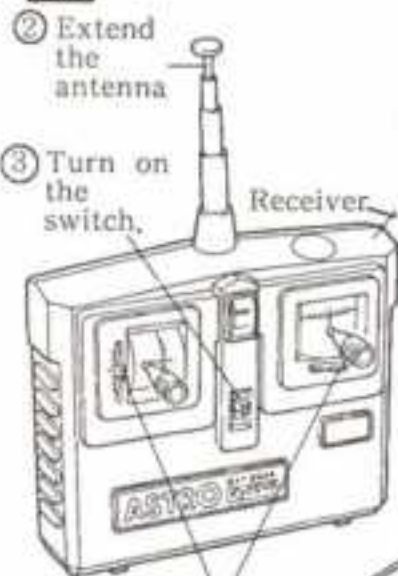

- Transmitter..... It is in effect a control box. Signal waves are transmitted through an antenna according to the stick movements.
- Receiver Receives the signals from the transmitter and send them to the servos.
- Servo They really move the control mechanism of a model car in accordance with the signals from the receiver
- Antenna An antenna on the transmitter sends signals, and one on the receiver accepts them. They should be fully extended.
- Trim Lever They will adjust the neutral position of servos, thus regulate the steering and advancing controls finely.
- Battery You can tell the amount of electricity in a battery and how the signals are emitted.
- Servo Horns They are intermediate devices on the servo to activate the controls. There are several types in shape. They should be selected depending upon the usage.

20 INSTALLATION OF STEERING

Step 1 Cut off shaded part.

M3x8 Bind Self Tapping Screws (2)

3 φ Washers (2)

⑦⑤ Ball End (S)

⑧⑤ Steering Rod (1)

Enlarge the hole with an awl so that the control rod can fit easily.

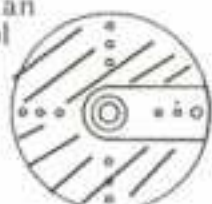

⑦⑤ Ball End (S) (TUL-7)

Step 2

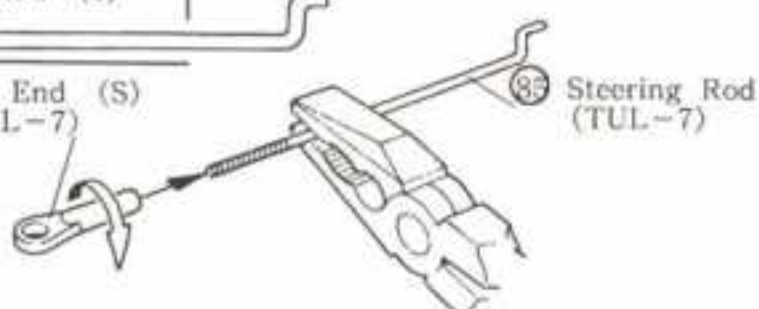

Step 3

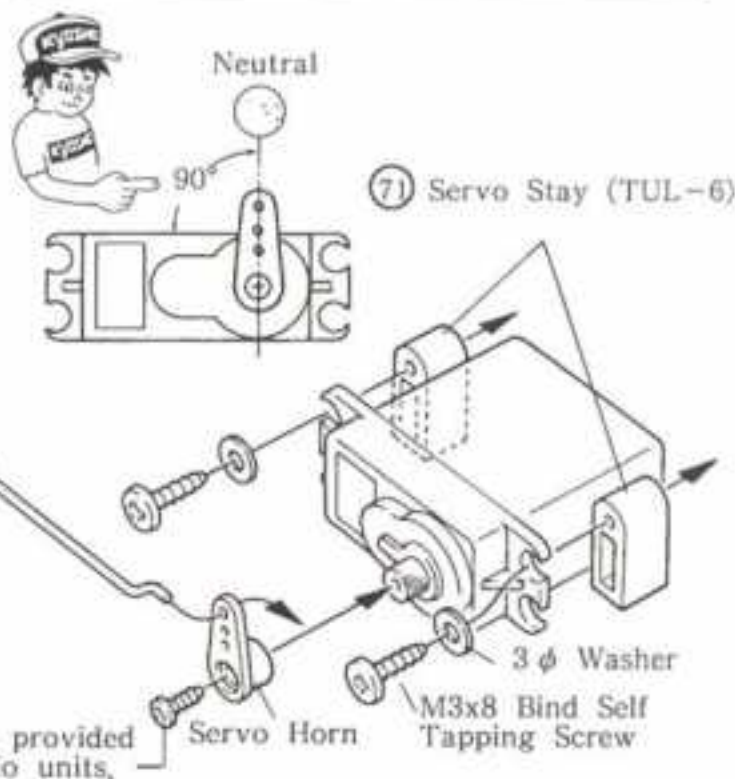

21 INSTALLATION OF STEERING SERVO

M3x8
Bind Self Tapping
Screws (2)

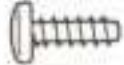

A You can change the length of the control rod by turning the ball ends.

To become longer.

To become shorter.

Bend it as shown in the drawing at right.

Adjust the length of the control rod as shown in A and the installing position as shown in B, so that the clearance indicated by C and D should become the same.

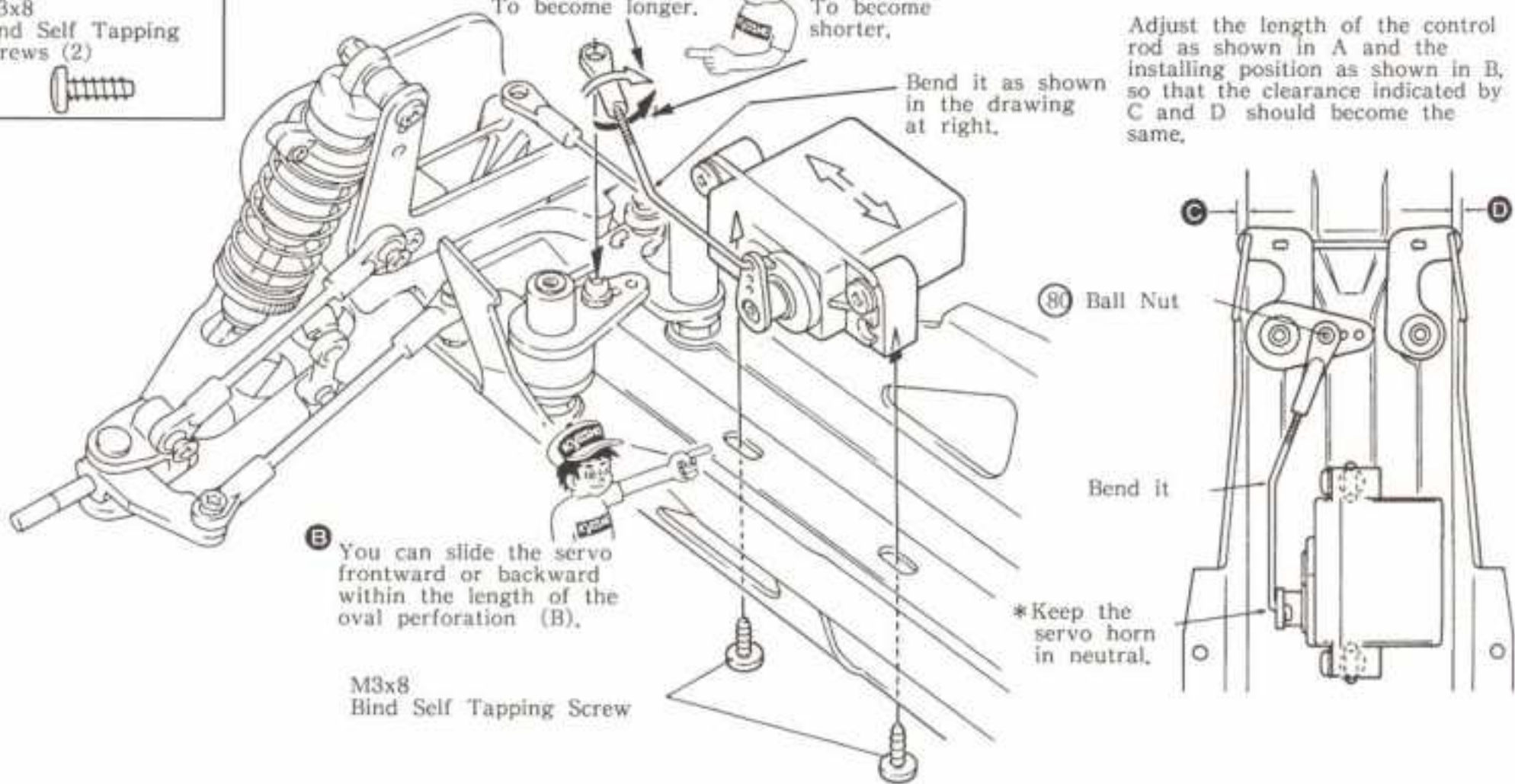

B You can slide the servo forward or backward within the length of the oval perforation (B).

M3x8
Bind Self Tapping Screw

22 MOUNTING OF RADIO PLATE

M2x8
Self Tapping
Screw (1)

M2,6x8 Bind Self
Tapping Screw (1)

M3x8 Bind Self
Tapping Screw (1)

M3x6
Bind Screws (2)

M3x10
Screws (2)

M3 Nuts (2)

82 8,4 φ Ball (1)

Step 1

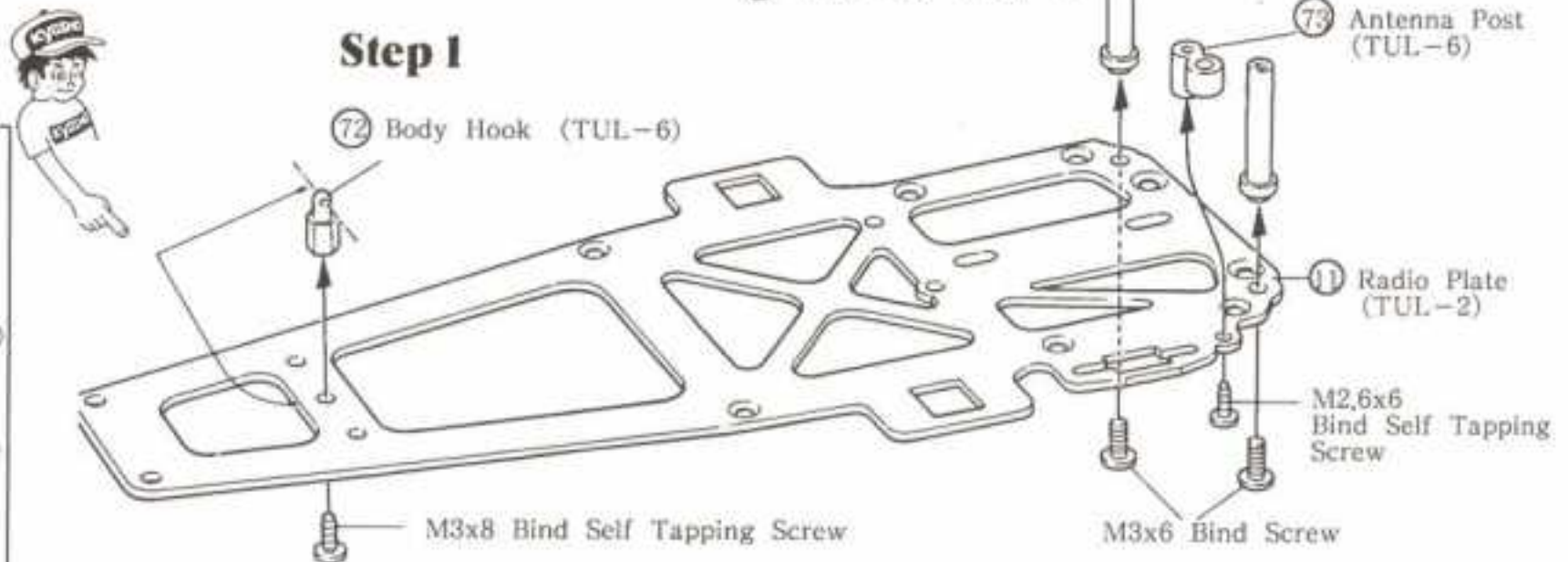

Step 2

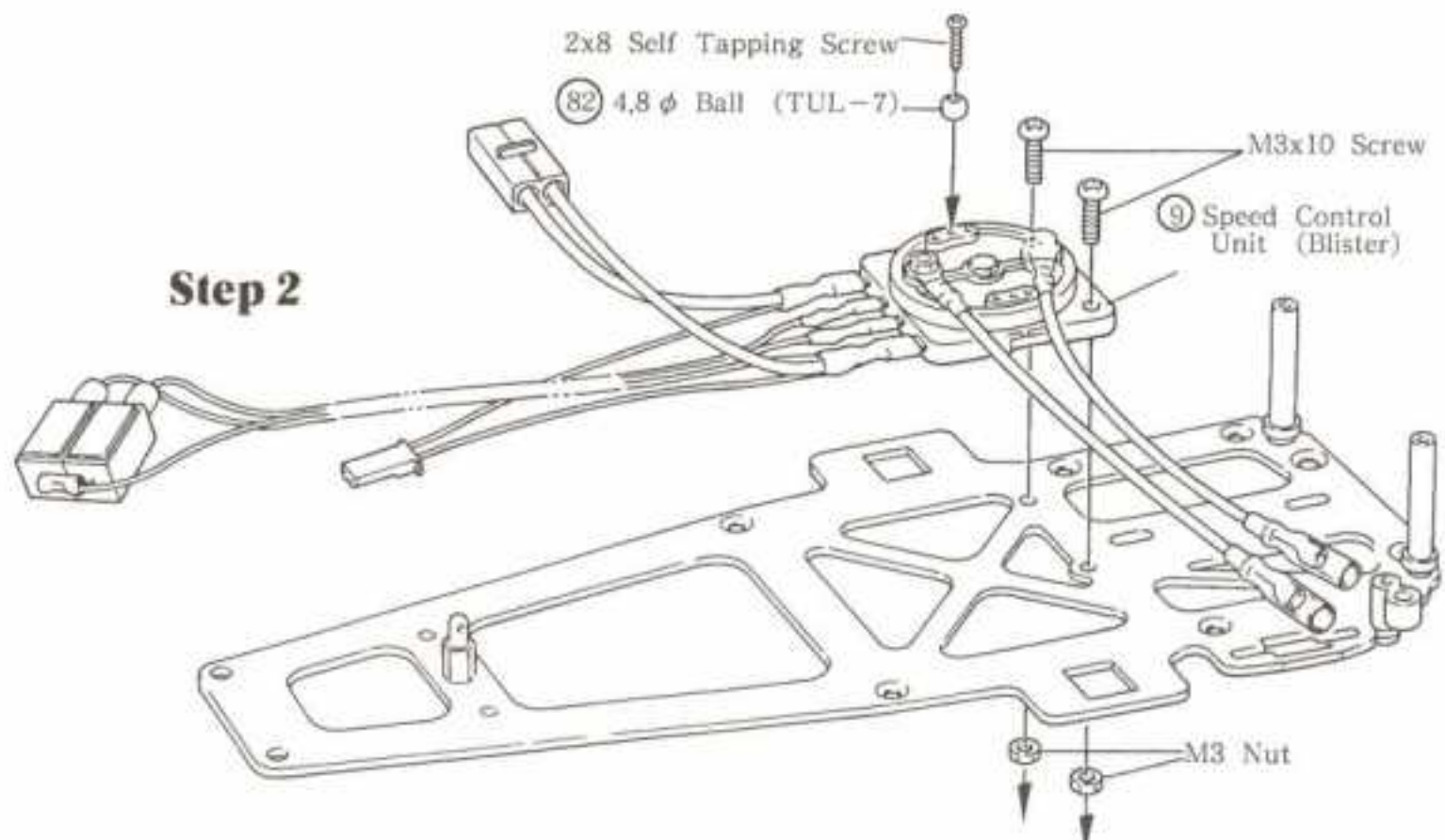

23 INSTALLATION OF SPEED CONTROL SERVO (71) Servo Stay (TUL-6)

Step 1 Cut off shaded part.

Enlarge the hole with an awl so that the control rod can fit easily.



Use a hole which is 15 mm away from the pivot.

Step 2

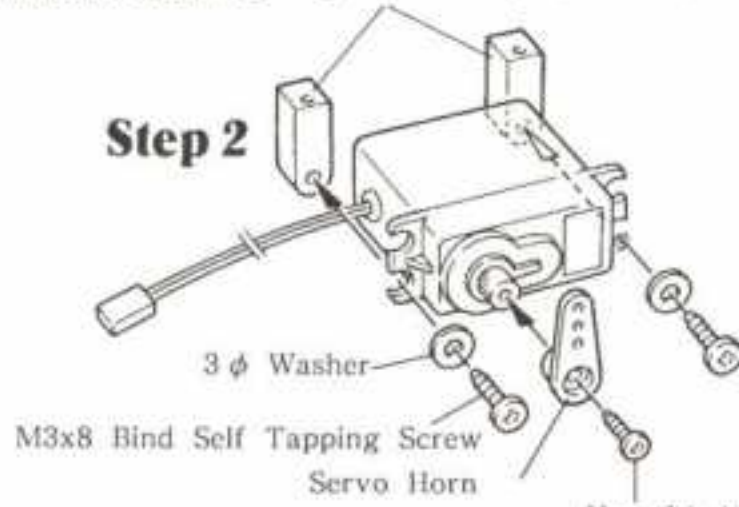

Use the screw provided with your radio units.

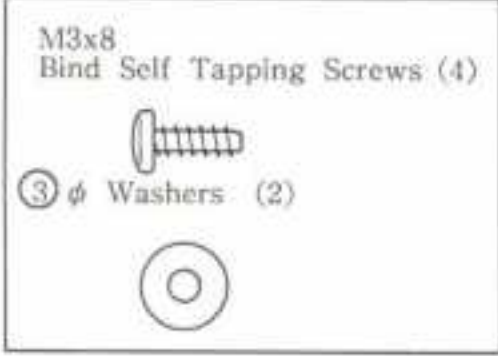
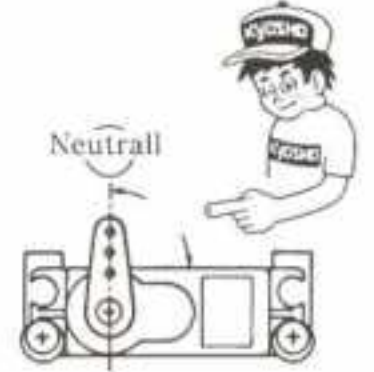

Step 3

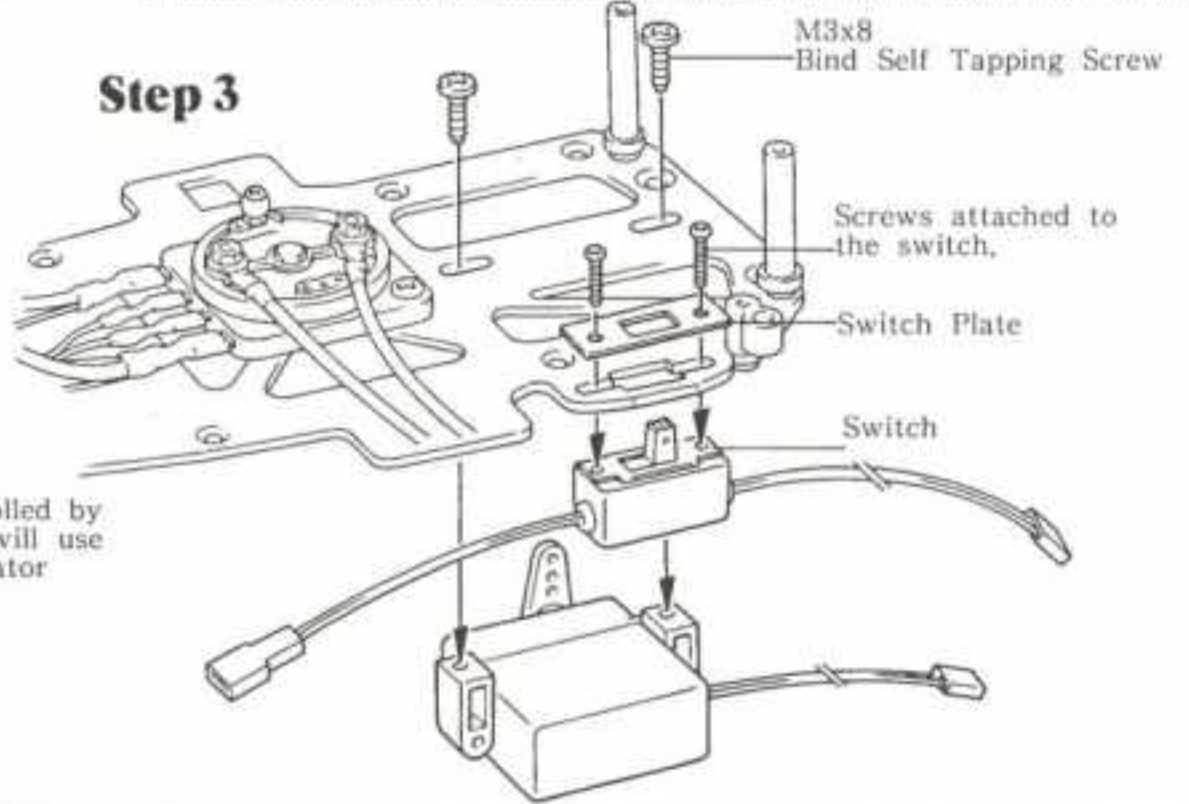

This model car is designed to be controlled by the BEC type radio only. Those who will use a non-BEC radio should have a regulator offered by the radio maker.

24 SPEED CONTROL LINKAGE

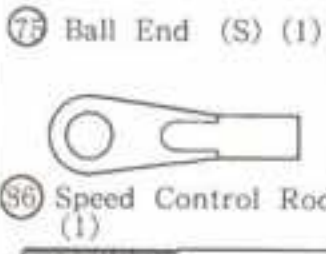

Step 1

5 Ball End (S) (TUL-7)

86 Speed Control Rod (TUL-7)

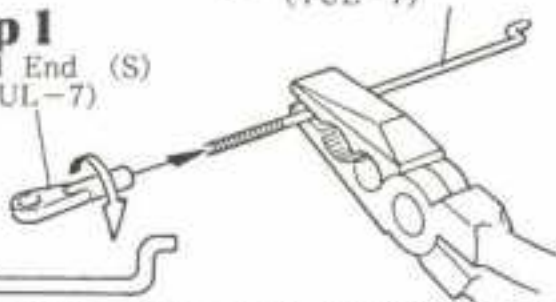

TOP VIEW

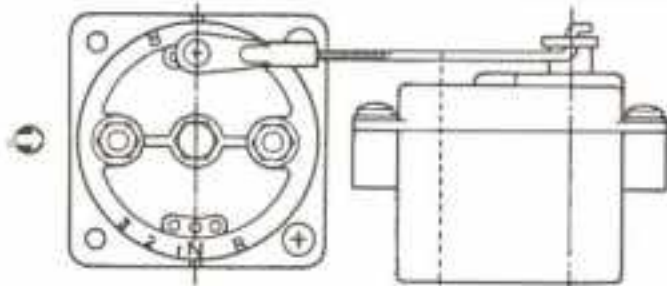

These lines should be parallel.

SIDE VIEW

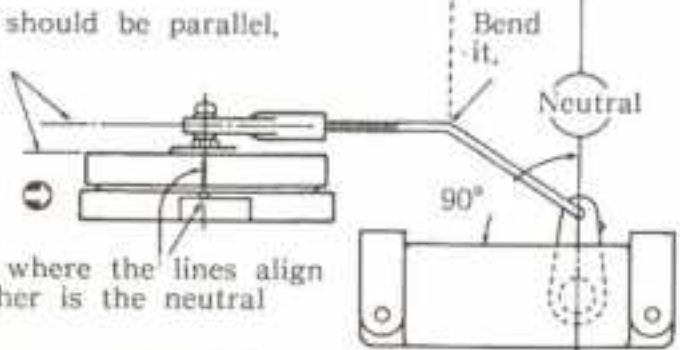

The position where the lines align with each other is the neutral setting.

Step 2

Adjust A and B so that the controller is set neutral as shown at left.



A You can adjust the length of the control rod by turning the ball end.

You can slide the servo frontward or backward within the length of the oval perforation.

It become shorter.

Getting longer.

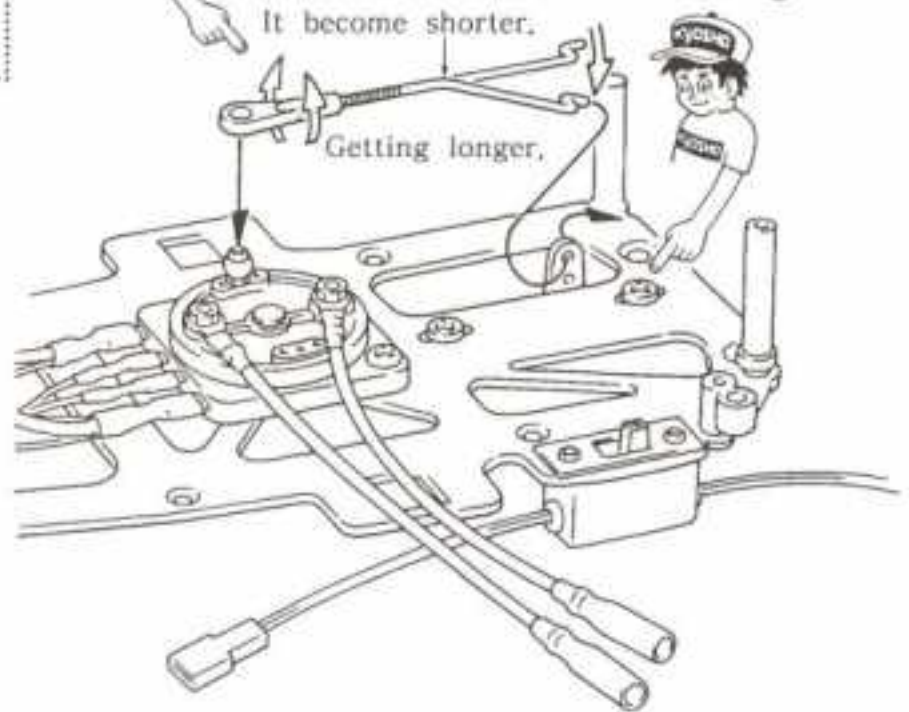

MOVEMENT OF CONTROLLER

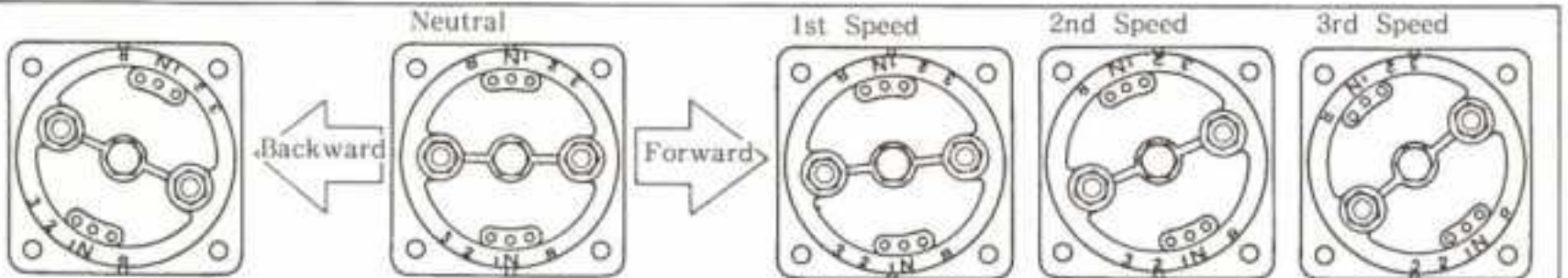

25 INSTALLATION OF RADIO PLATE

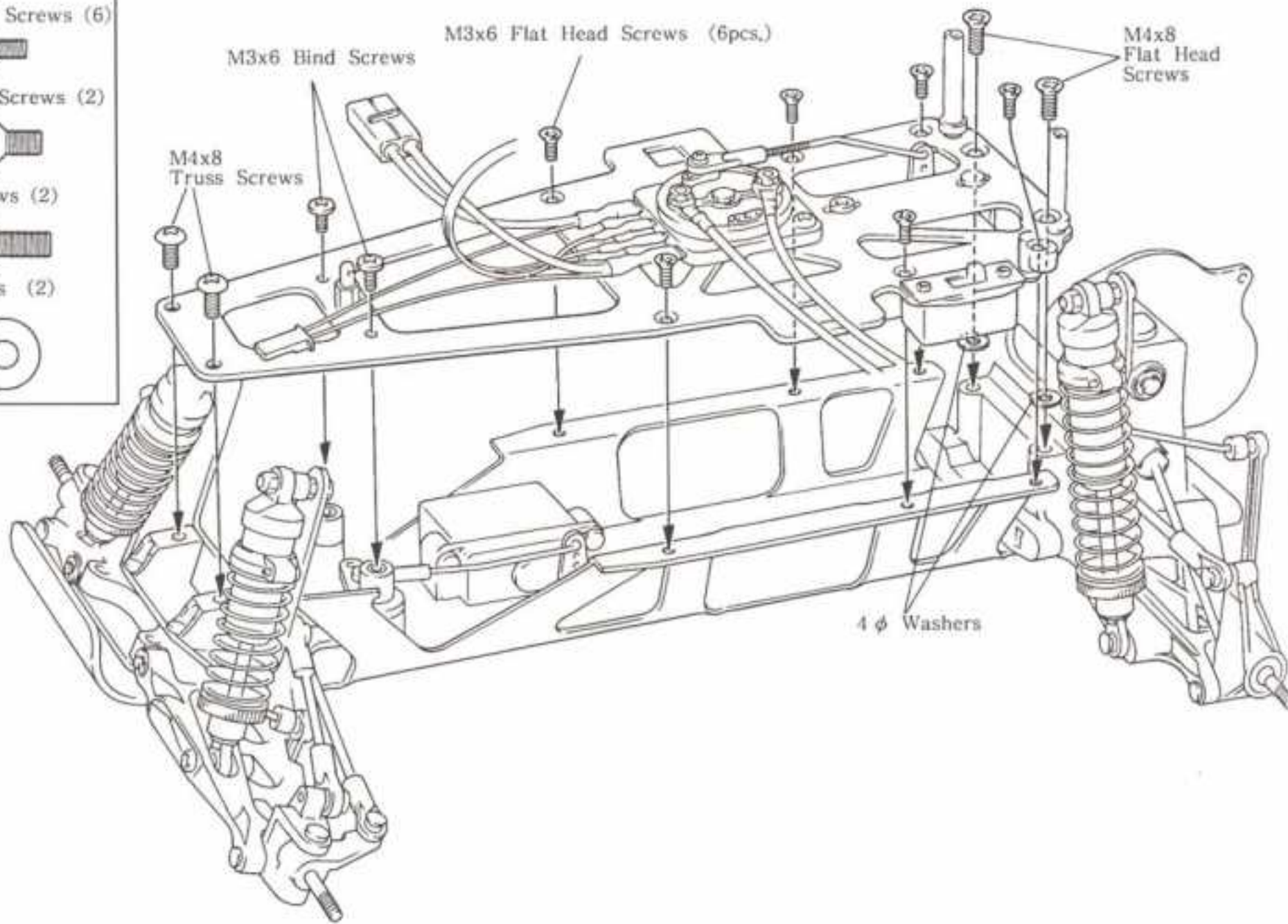
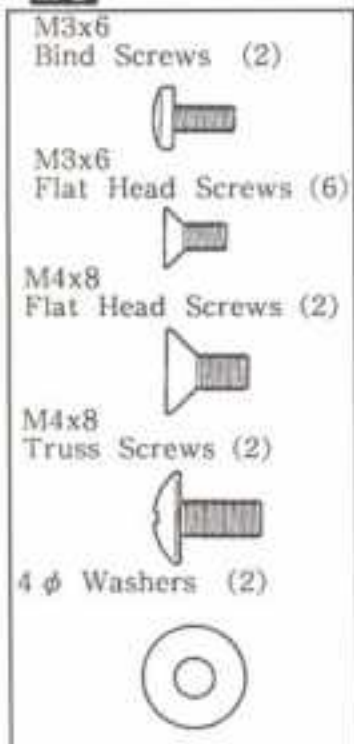

26 INSTALLATION OF RESISTOR

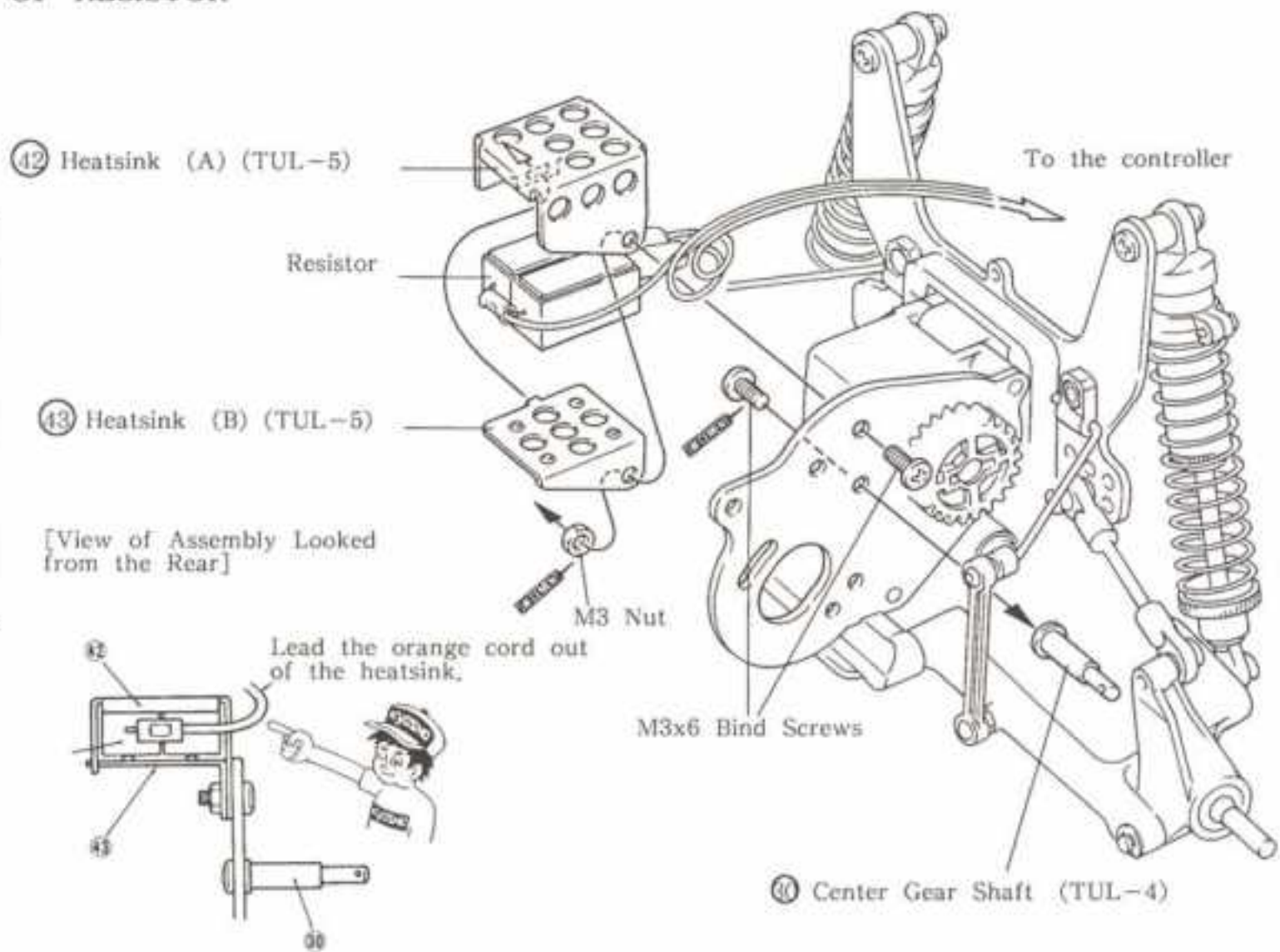
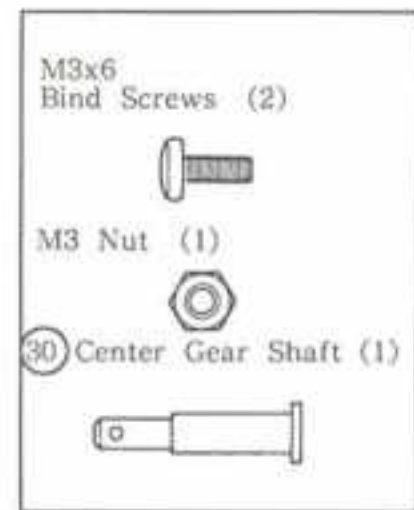

27 INSTALLATION OF CENTER GEAR

4 ϕ Washers (2)



4 ϕ x8 Bearings (2)



38 O Ring (P3) (1)



39 Center Gear Collar (1)



Remainings of the decal.

This hole is for installing the optional motor guard. When you don't employ the motor guard, put a surplus piece of decal over the hole so as to prevent any dust from entering.

4 ϕ Washer

6 4 ϕ x8 Bearing (Blister)

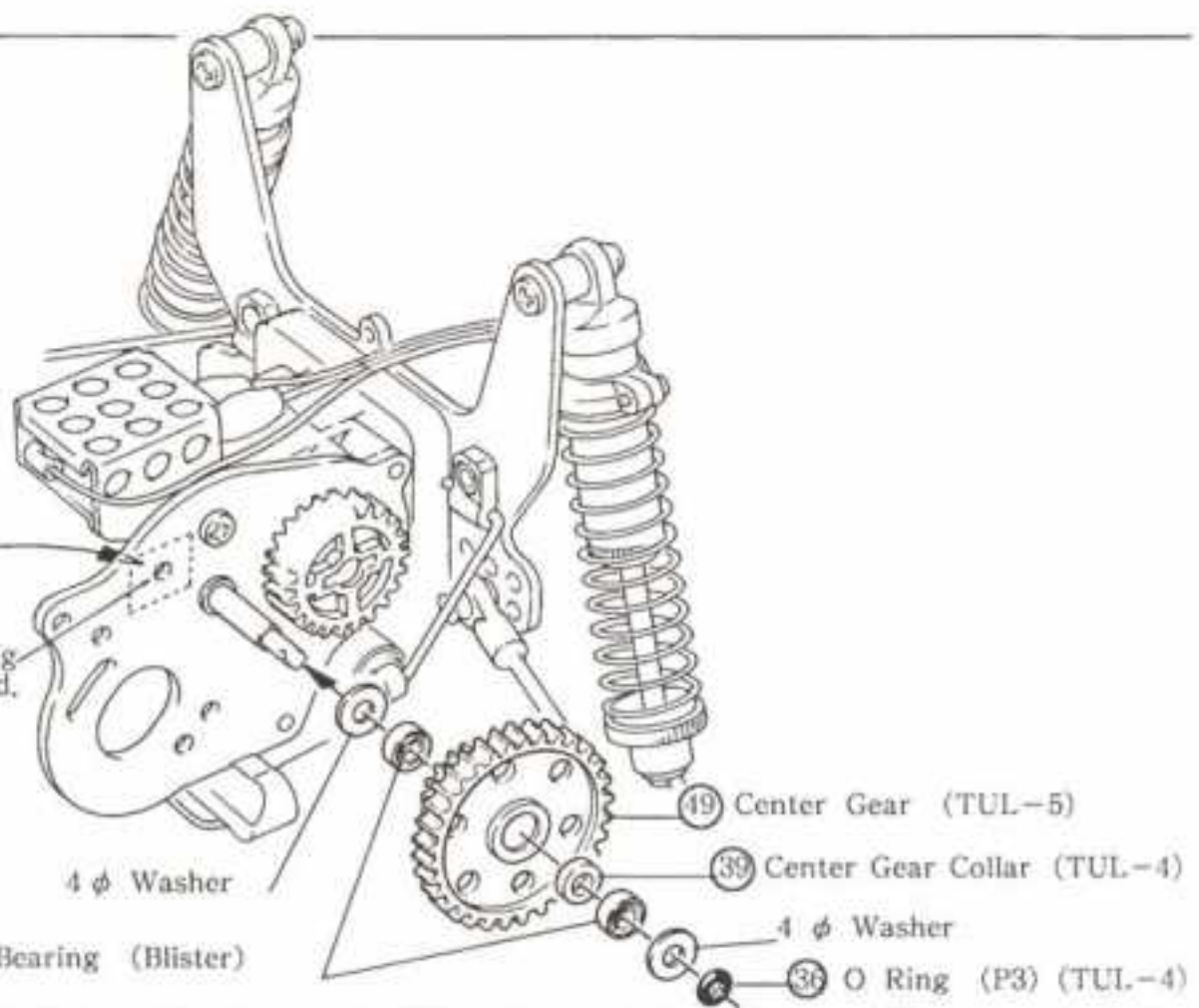

28 INSTALLATION OF MOTOR

14 Motor Cord (TUL-2) **Step 1**
 10 Le Mans 240ST Motor (Blister)

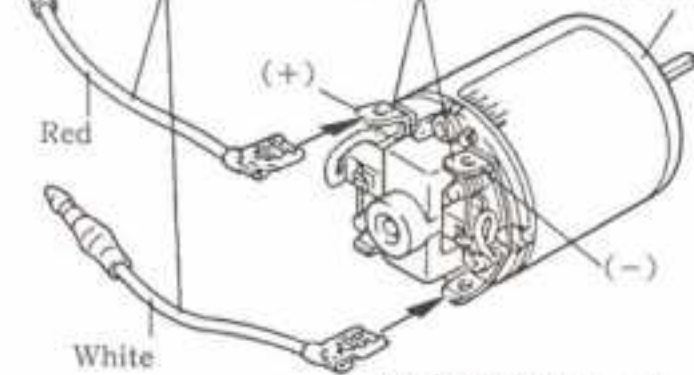

[Adjusting way of backlash]

M3x3 Set Screw (1)

M3x6 Bind Screws (2)

Loosen these two screws and move the upper screw in the way of the arrow to adjust backlash (meshing degree of the gear teeth.)

Step 2

Plug in.

To the controller

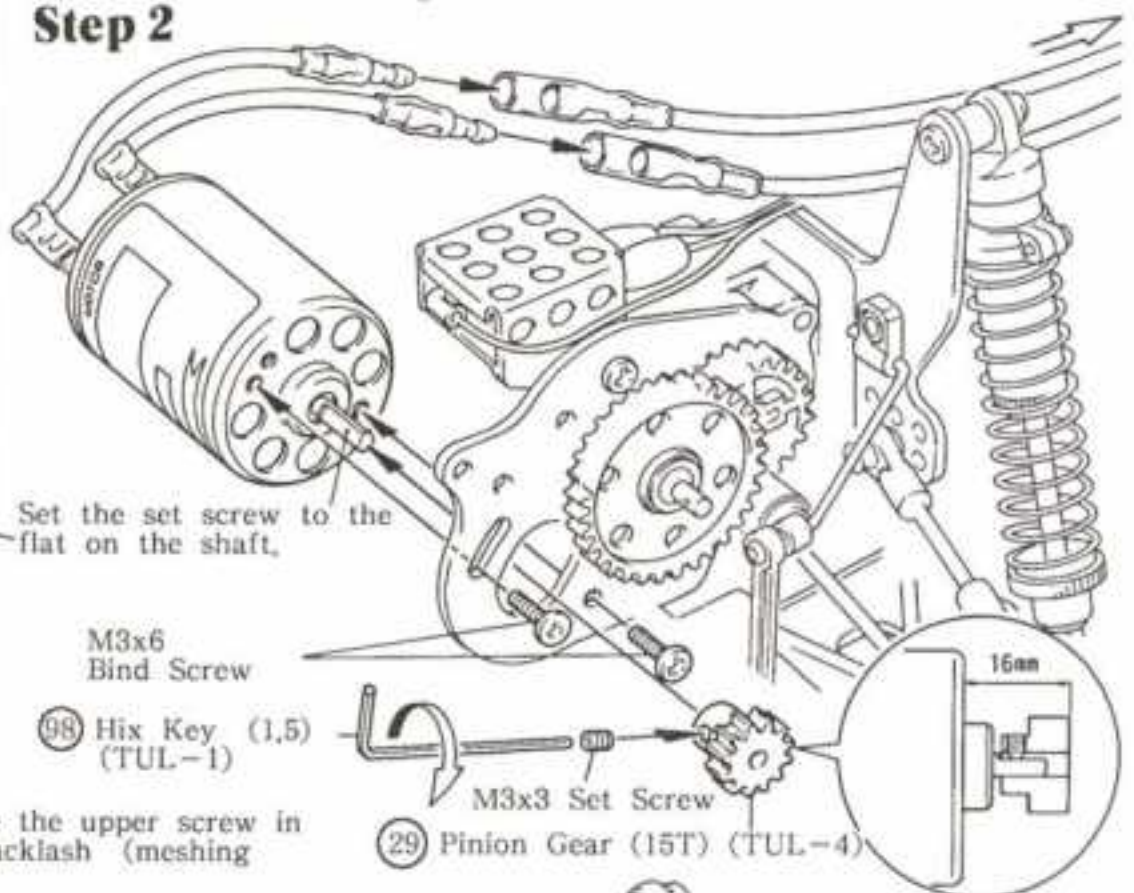

29 INSTASLLATION OF GEAR COVER

59 Gear cover (TUL-6)

37 Hook Pin (1)

Cut the gear cover seal to the length.

16 Gear Cover Seal (TUL-2) (Foam Rubber)

(Remove the backing paper and put the seal along the area indicated with diagonal lines.)

97 Hook Pin (TUL-1)

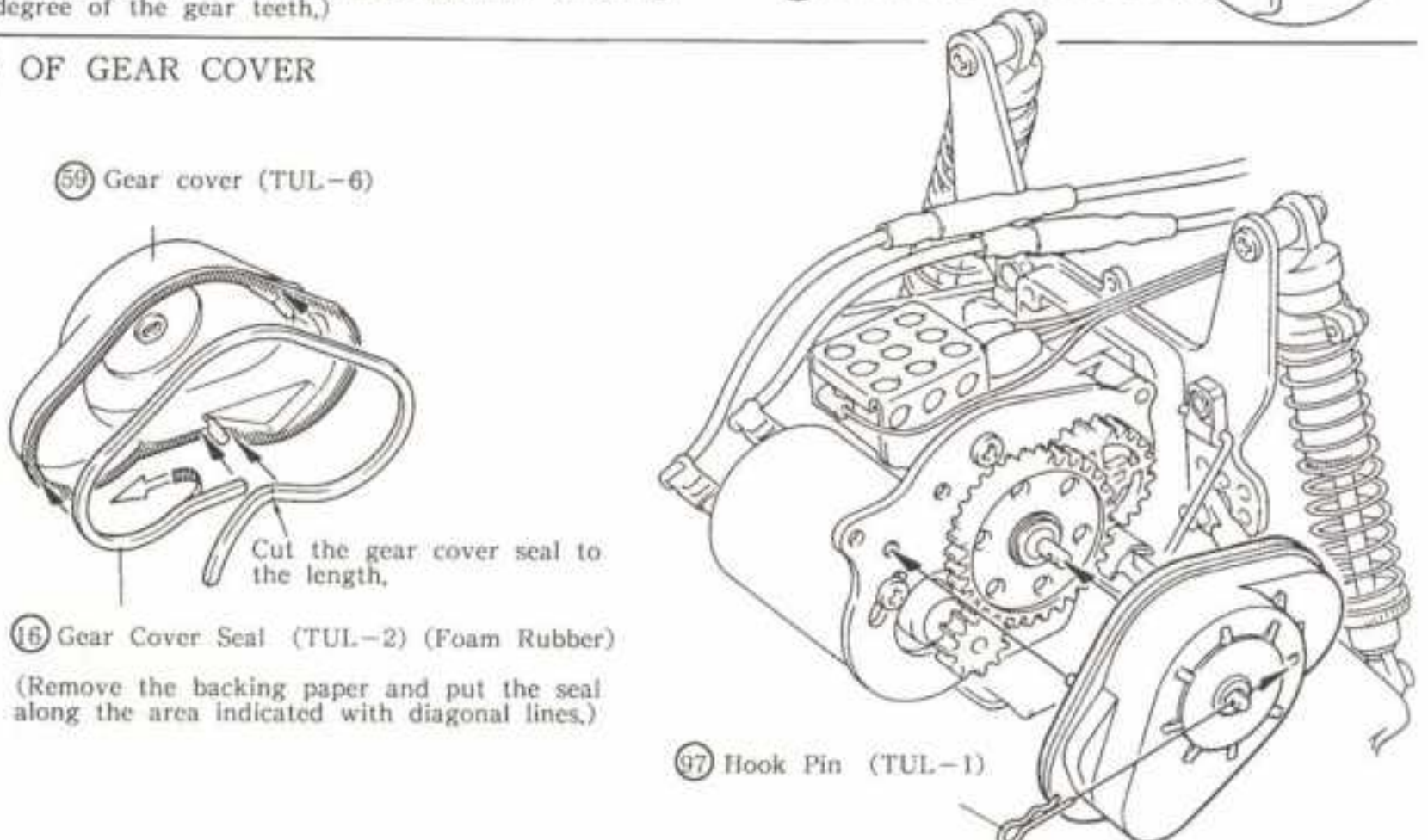

30 ASSEMBLY OF WHEEL AND TIRE Step 2

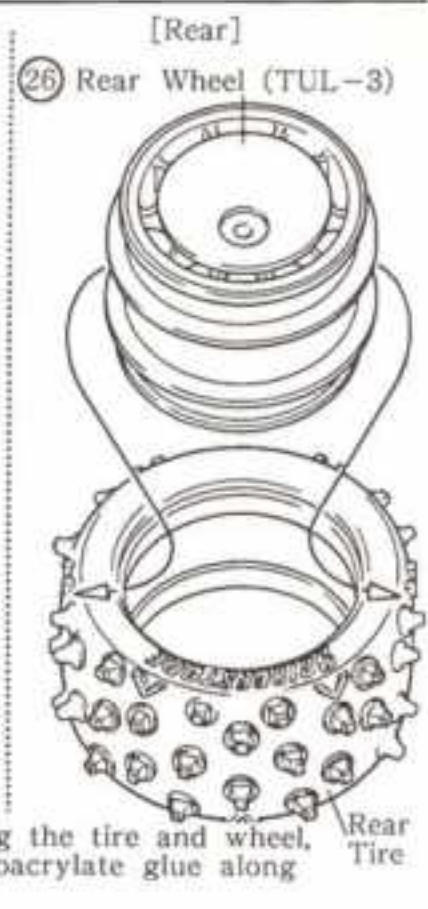
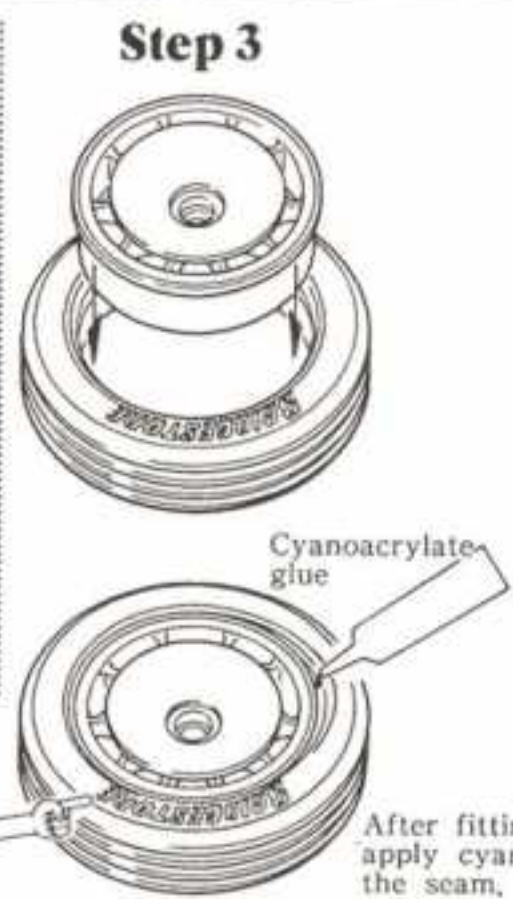
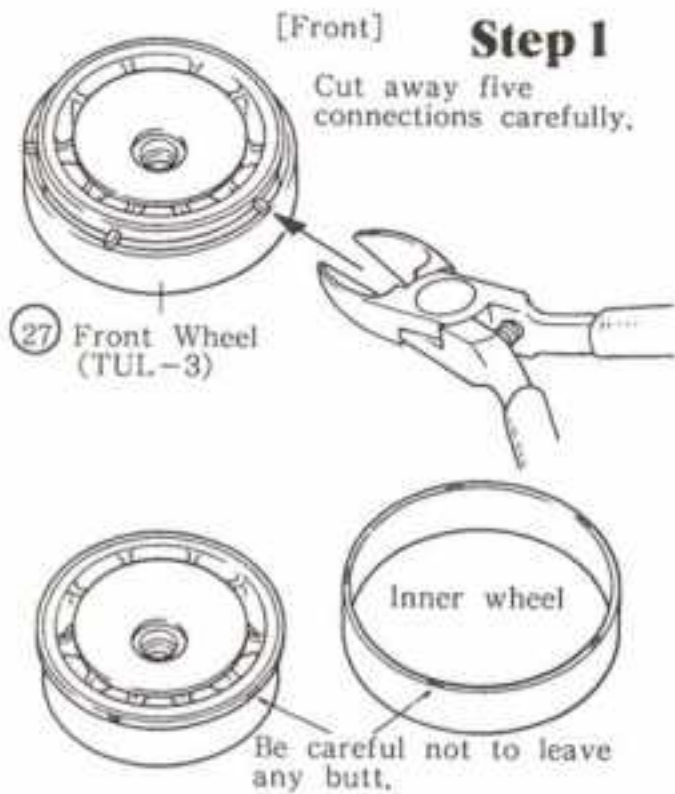

31 INSTALLATION OF TIRE

- M4 Nylon Nuts (4)
- 6 4 φ x8 Bearings (4)
- 31 Drive Washers (2)
- 6 4 φ x8 Bearing (Blister)

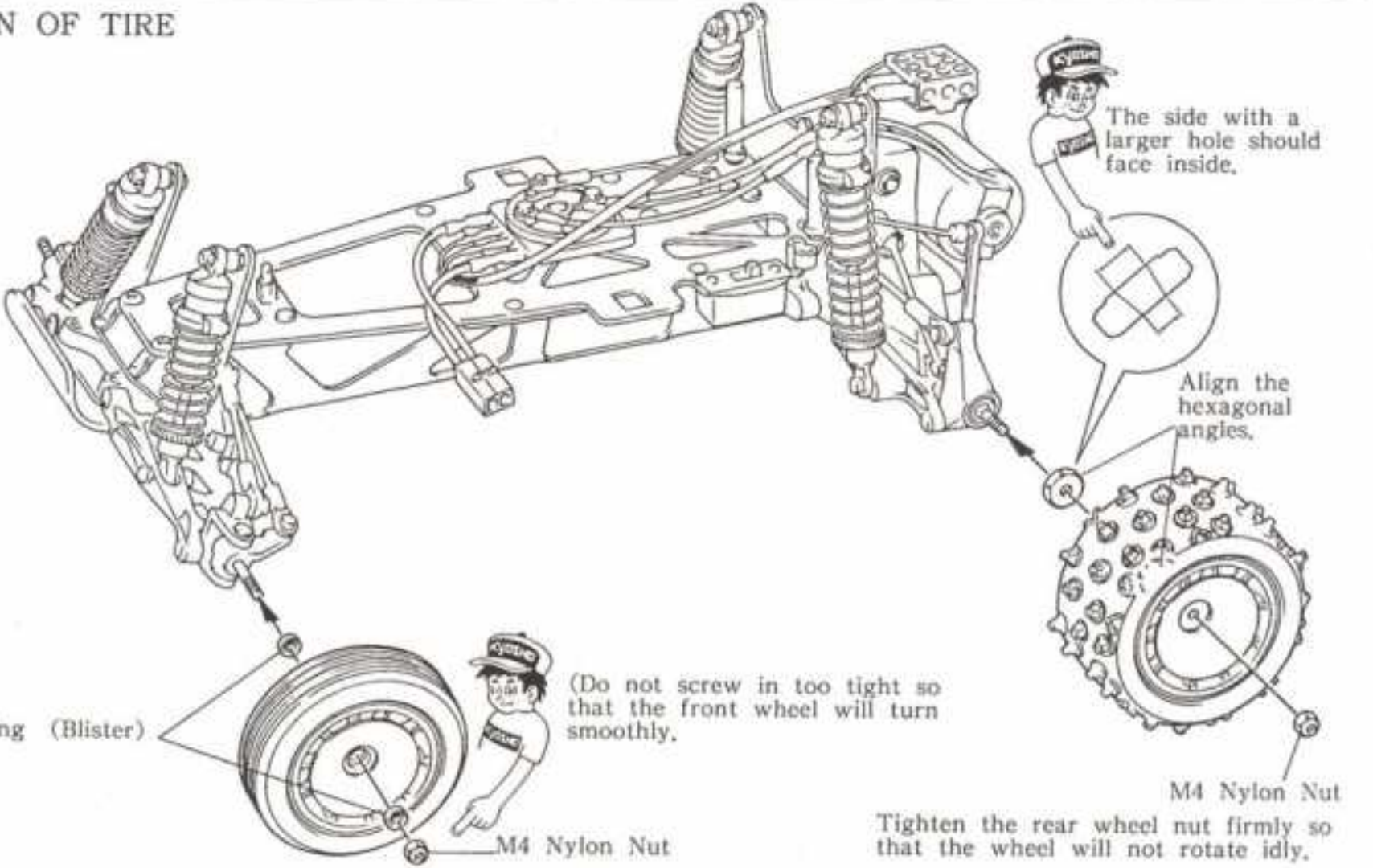

32 MOUNTING OF RECEIVER

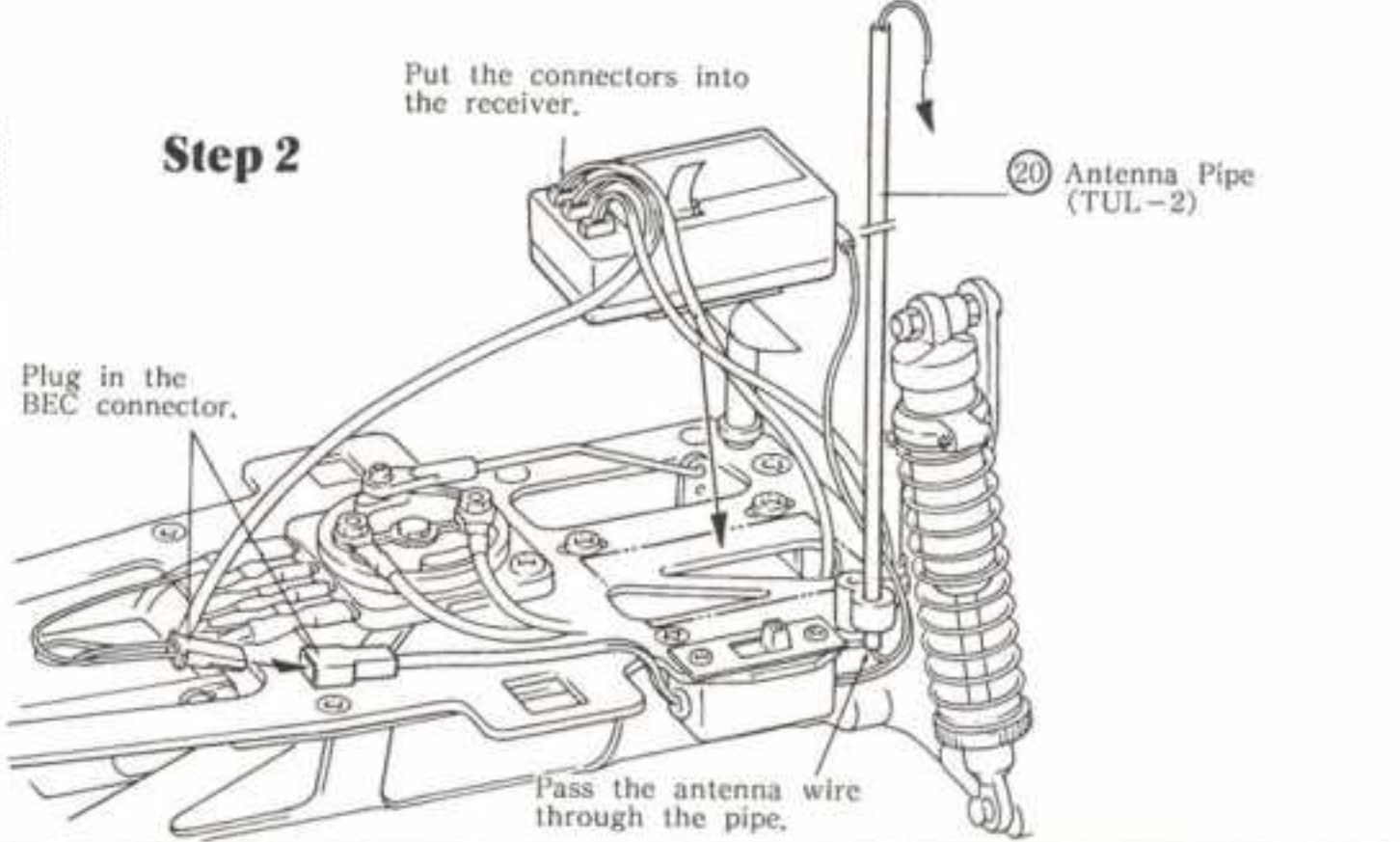
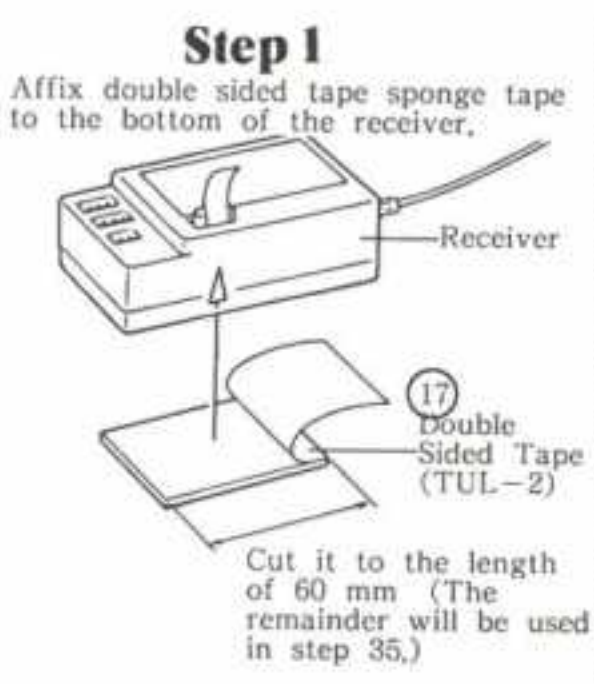

33 CUTTING OF BODY AND WING

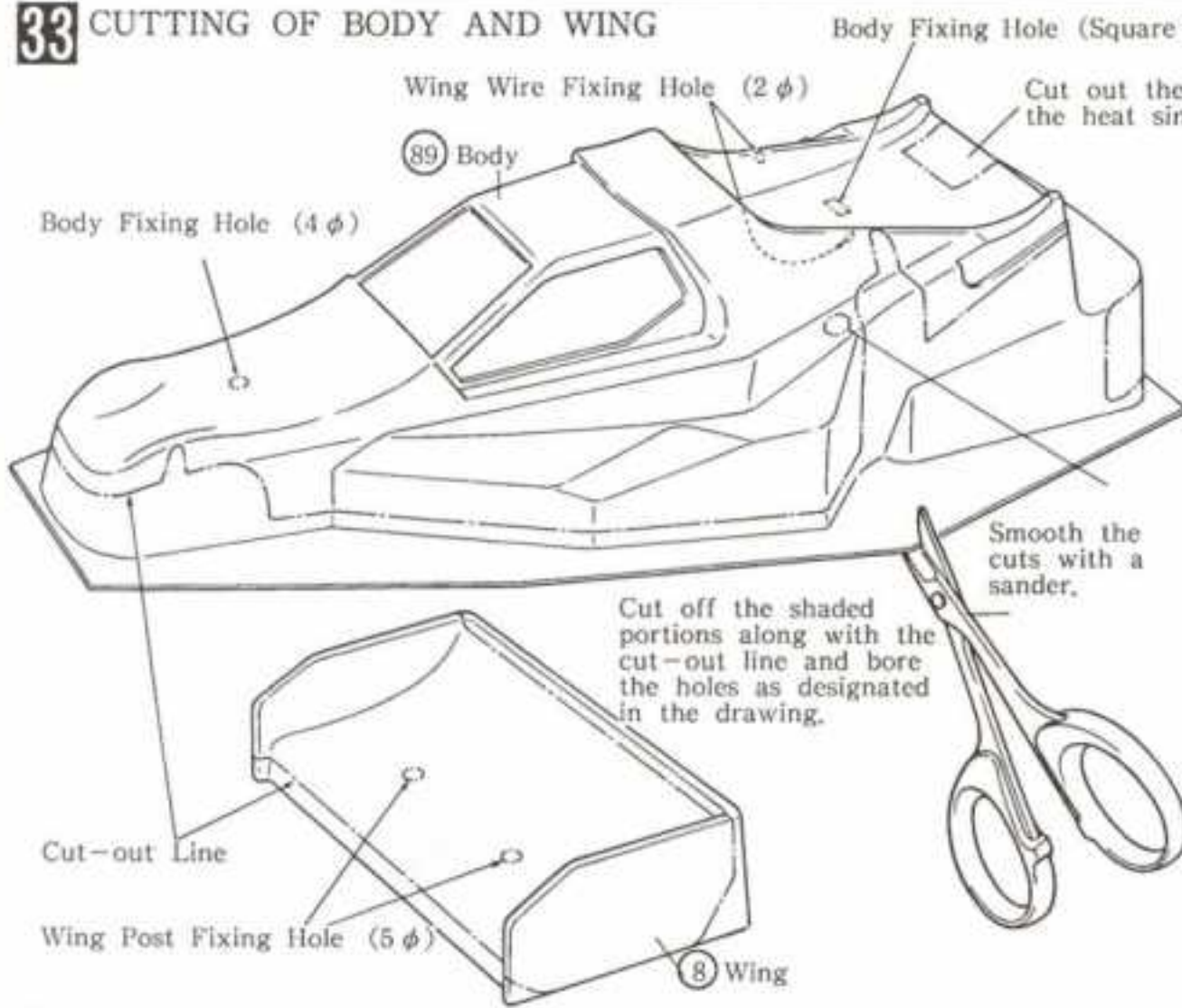

KYOSHO

The shears for cutting polycarbonate is available from Kyosho, No.1829

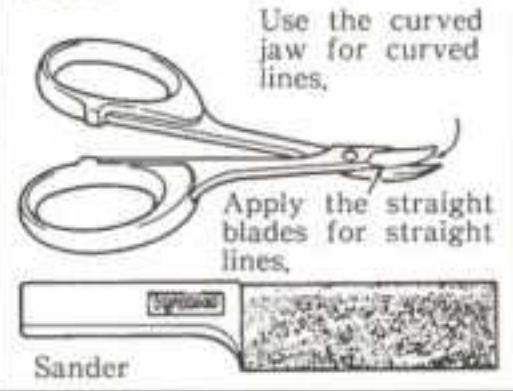

34 PAINTING

The body of this model of polycarbonate, a transparent plastic resin moulded into shape. It is recommended that the inside of the body is painted, this will give a better finish. For better paint adhesion wash the inside of the body with a neutral detergent and rinse it well with water.

Whilst the body is drying be careful not to stain the surface with thumb marks. If you paint your Turbo Ultima in one color only 2-3 coats of paint will be sufficient. If you like to paint it with a coloring scheme in more than two colors, mask the inside with masking tape or the Micron Line Tape according to your scheme and start with the darkest paint, and lastly apply the lightest color, all over the area.

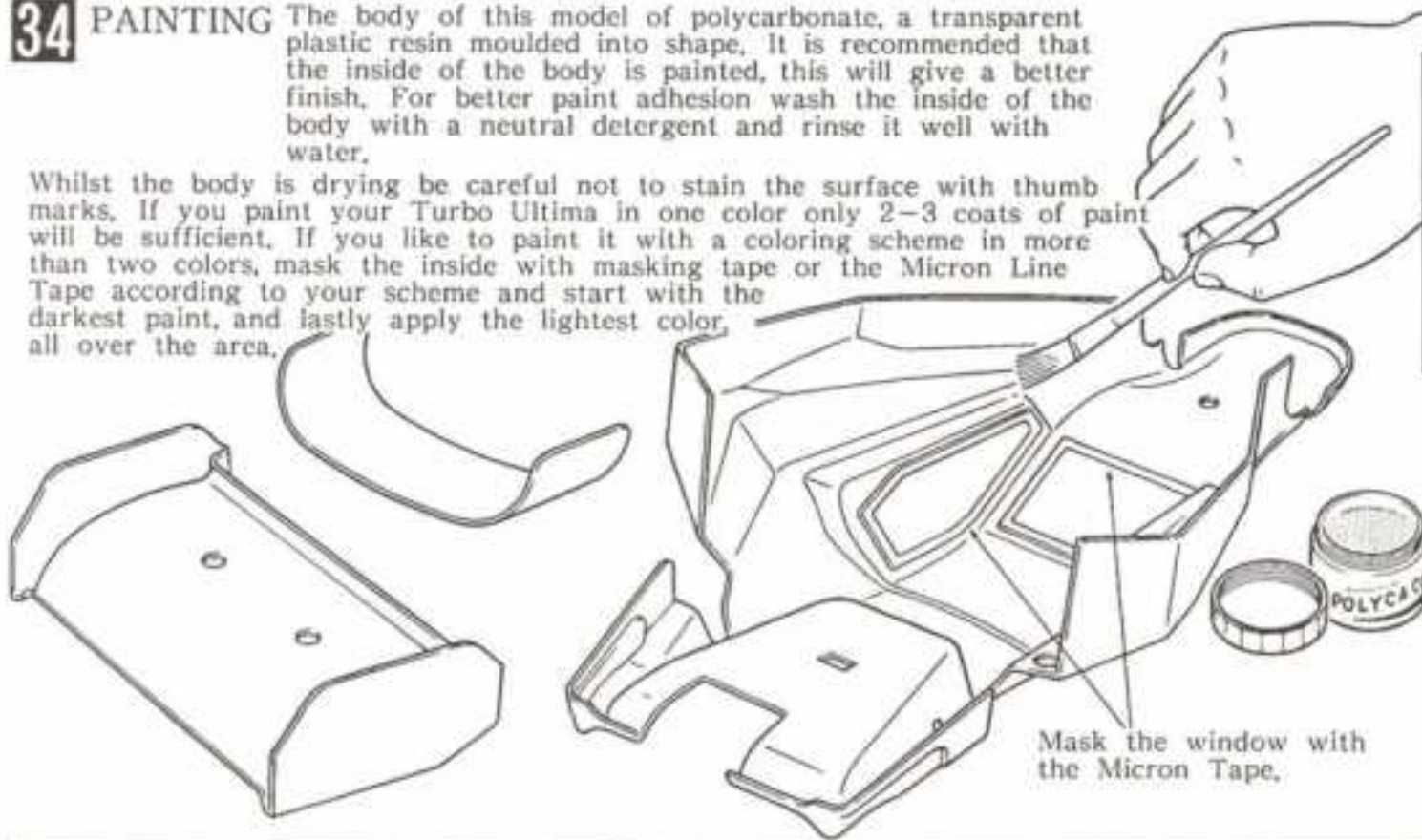

KYOSHO

Micron Line tape or equivalent can be used as make patterns. They are available in different colors and widths.



KYOSHO

Polyca Colors are paints Composed exclusively for painting polycarbonate resin. They are very easy to use. Different colors are available.



35 ASSEMBLY OF BODY AND WING

Cut out the decals as close as to the cutout line, and affix them as shown.

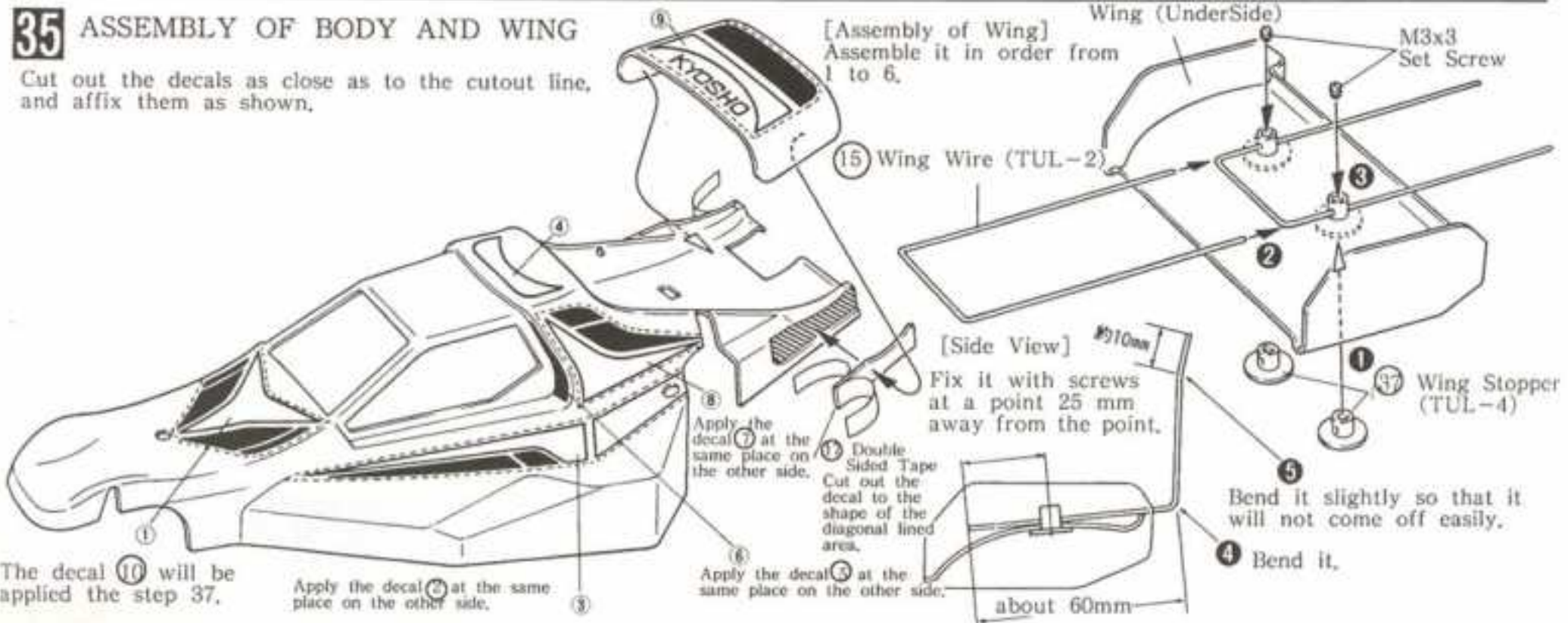

36 INSTALLATION OF BATTERY

*WHEN YOU KEEP THE MODEL NOT RUNNING FOR SOME TIME OR STORED, REMOVE THE BATTERY FROM THE MODEL WITHOUT FAIL.

Push this trigger when removing the battery pack.

Step 1

88 Battery Holder (TUL-7)



Remainings of cellophane tape or decals.

Step 2

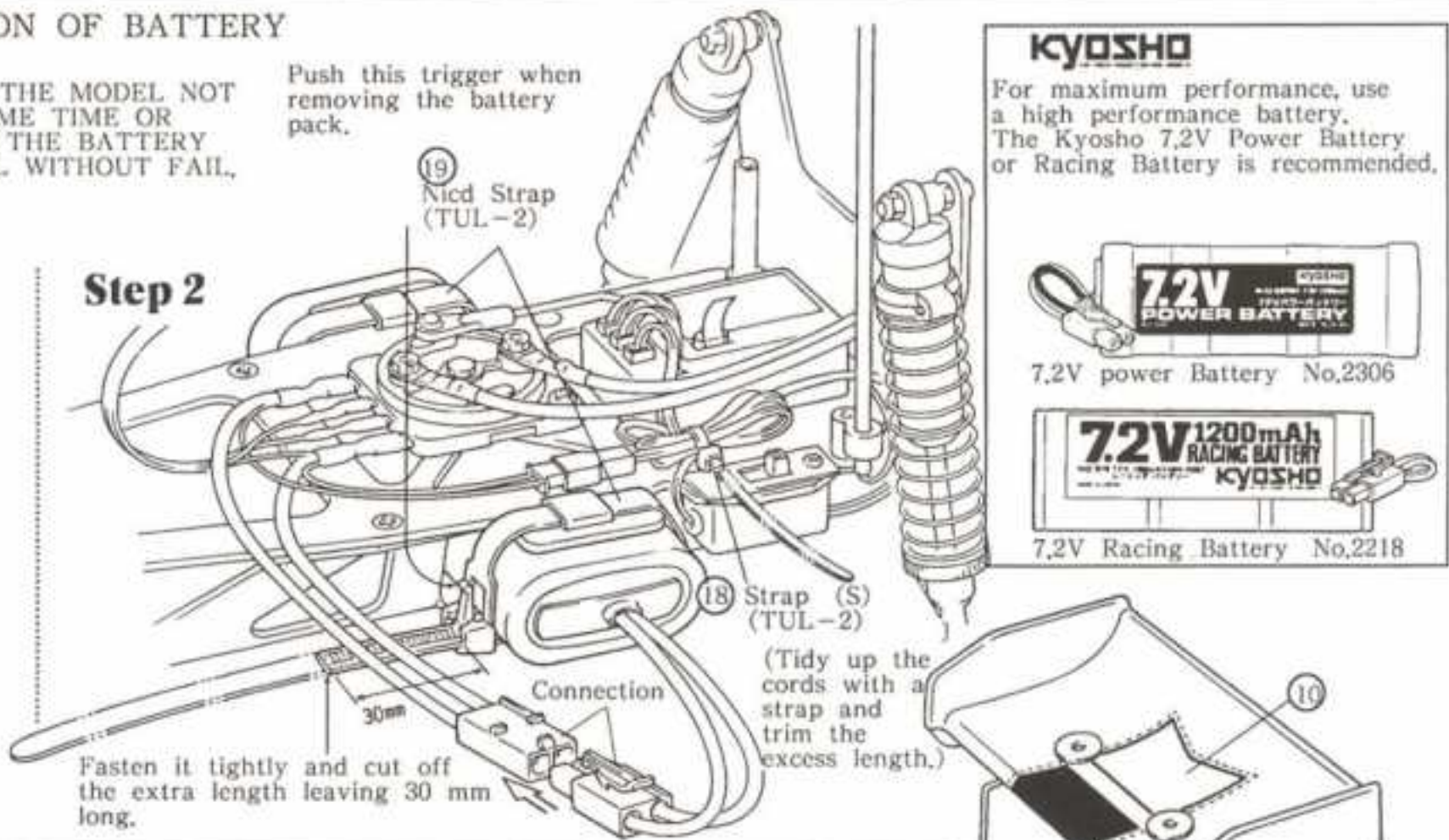

Fasten it tightly and cut off the extra length leaving 30 mm long.

KYOSHO

For maximum performance, use a high performance battery. The Kyosho 7.2V Power Battery or Racing Battery is recommended.



7.2V power Battery No.2306



7.2V Racing Battery No.2218

37 MOUNTING OF BODY AND WING

100 Body Pin (TUL-1)

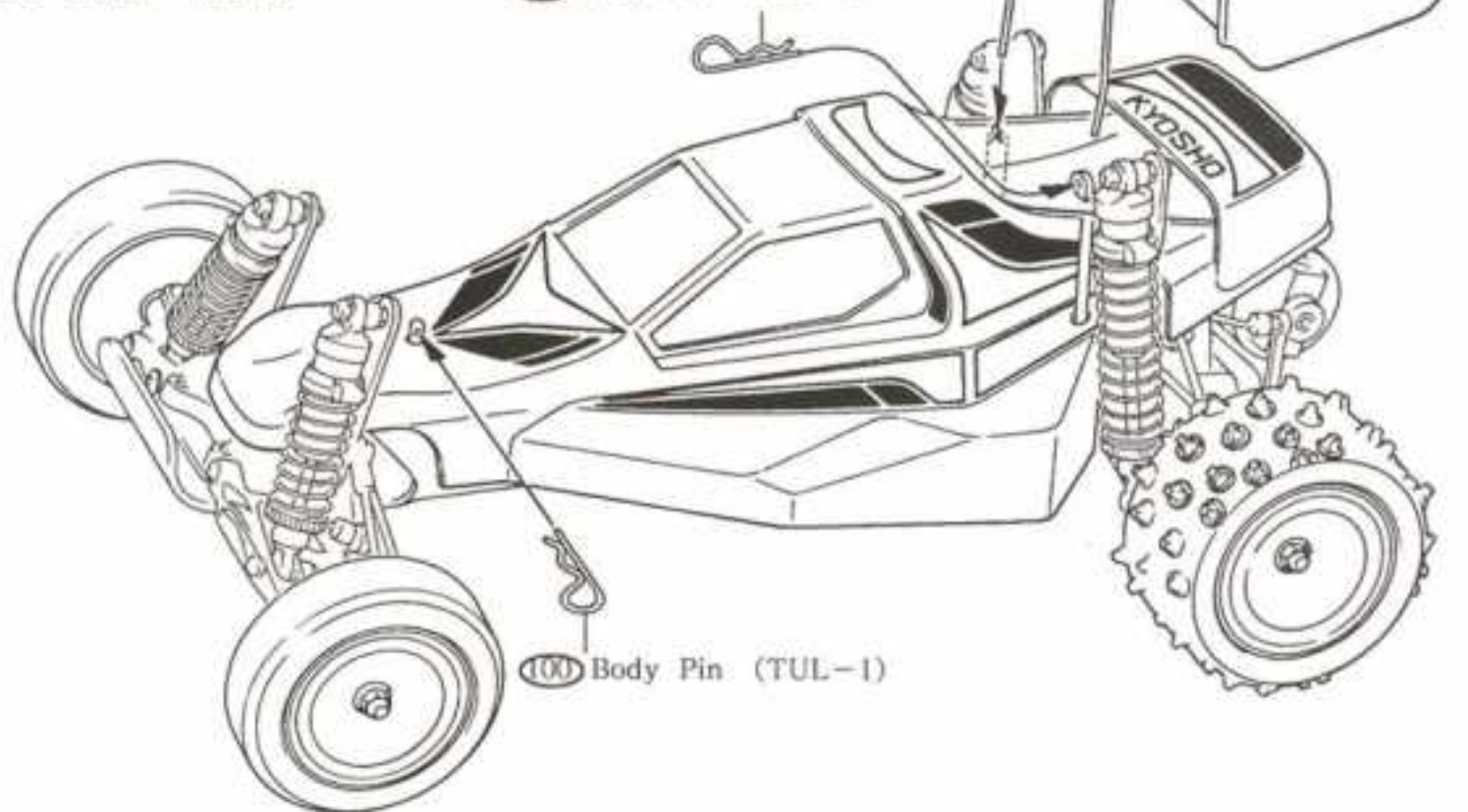

100 Body Pin (TUL-1)

WIRING

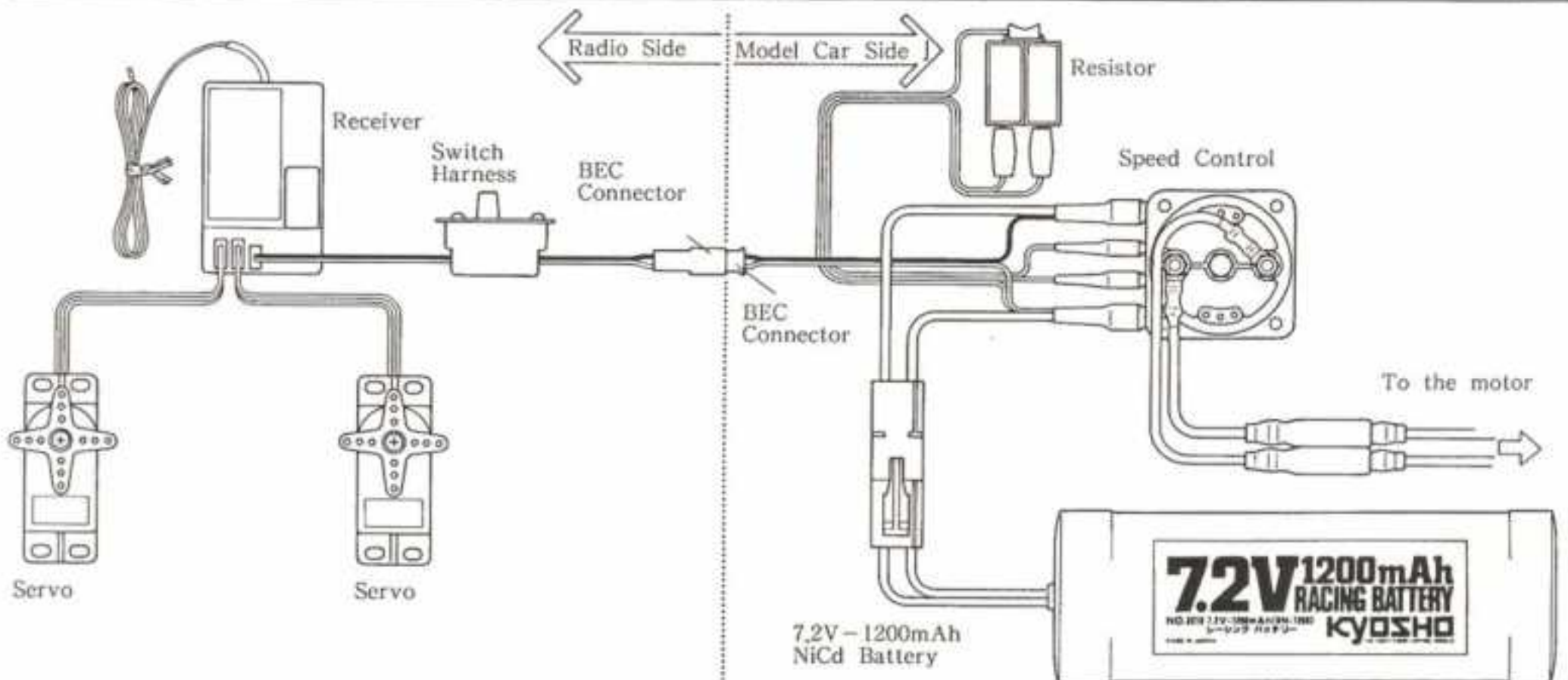

Servo

Servo

7.2V - 1200mAh NiCd Battery

7.2V 1200mAh RACING BATTERY
NO. 2218 7.2V-1200mAh NiCd
KYOSHO

To the motor

GUIDE FOR CHARACTERIZING MODEL (1)

[Adjustment of Ball Differential before Assembly]

Adjust the differential before installation by tightening the M2.6x15 screw in such a degree that the differential will not turn idly as shown in illustration ① and the differential gear shaft will turn smoothly in the reverse way as shown in illustration ②

- 1 Hold the differential by inserting screwdrivers, then tighten the cap screw little by little so that the gear will not rotate idly. Tightening the cap screw too much or letting the differential operate without tightening the cap screw may damage the plate or balls in the system.

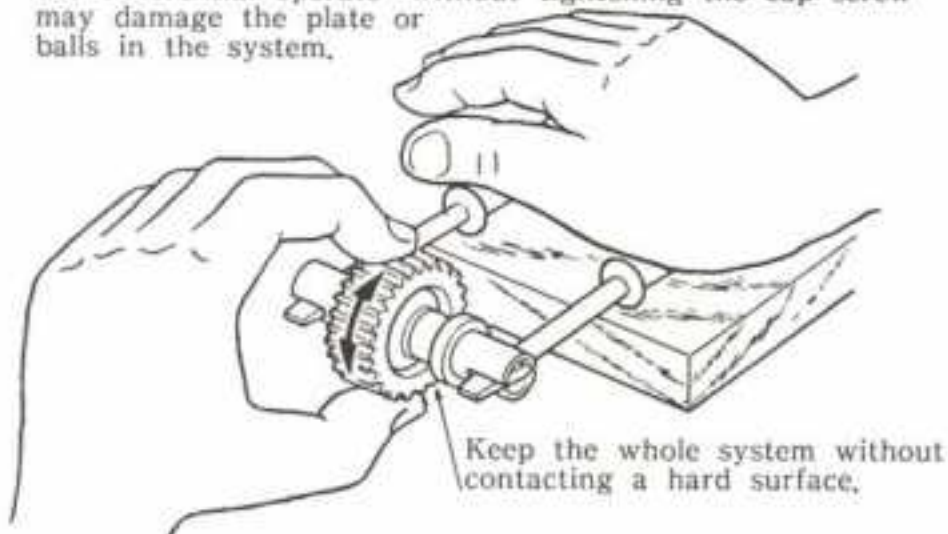

- 2 Hold the differential gear by your fingers, and check to see if the other side will turn in the opposite direction to your drive on one side. This movement is called the differential effect. The more you tighten the cap screw, the less the effect becomes.

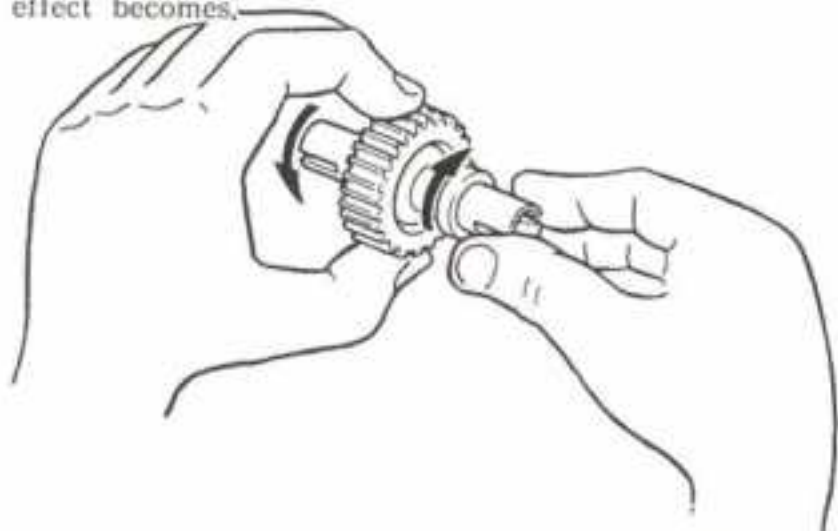

- 3 Repeat the steps ① and ② until you get the ideal adjustment, then put the sponge cap into the shaft of the end where the cap screw is fixed.



[Relation between Motor and Ratio]

No. of Pinion Gear Teeth	14T	15T	16T	17T	18T	19T	20T
Gear Ratio	8.8	8.2	7.7	7.3	6.9	6.5	6.2
Compatible Le Mans Motors	240 S, 240 SB						
			360 GOLD, 360 PT				
	480 S, 480 T, 480 GOLD						

[When the Center Gear is Too Tight to Fix]

All parts of this model are precision-worked, so sometimes you may find the center gear is too tight to install, the step is in 27 "Fixing of Center Gear" on page 13. In such a case, disassemble the center gear shaft once as shown below and enlarge the shaft hole with a round file a little bit.

Step 1

Take out the center gear shaft once.



Step 2

File off the hole 0.1 to 0.3mm to the direction as indicated with an arrow.

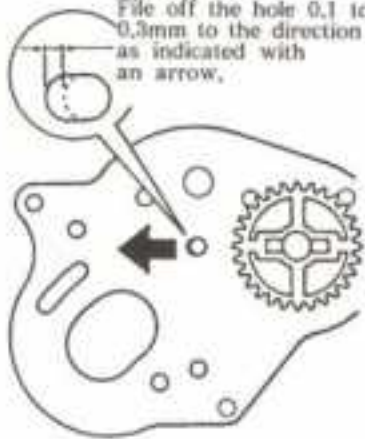

Step 3

Install the shaft pushing it toward the direction of the arrow.



Center Gear Shaft

[Adjustment of Ball Differential after Assembly]

The ball differential gear has been adjusted as shown at the left column. But after the assembly, take a look in the following ways if the cap screw is tightened properly.

- 1 Remove the gearbox cover first, then put a piece of foam rubber or thick paper between the center gear and the pinion gear to lock them.

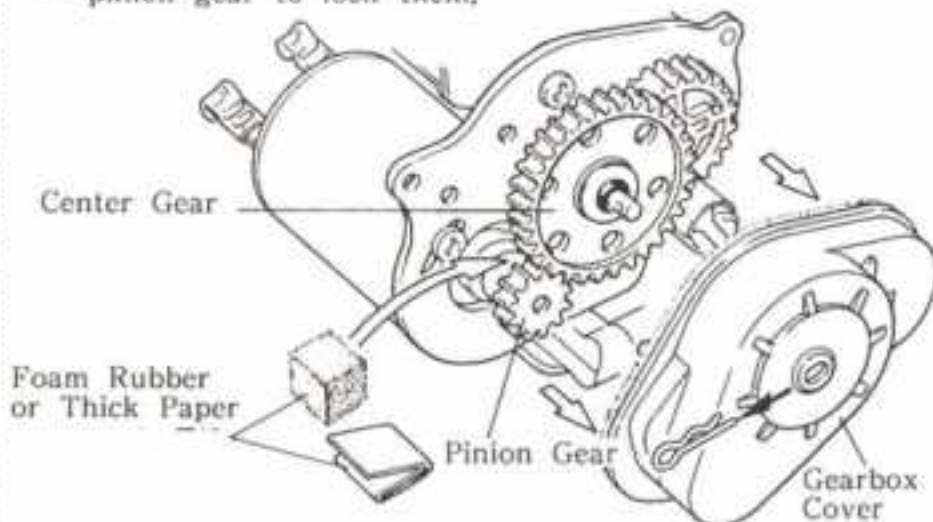

- 2 Hold the rear wheels with your both hands and raise the model vertically.

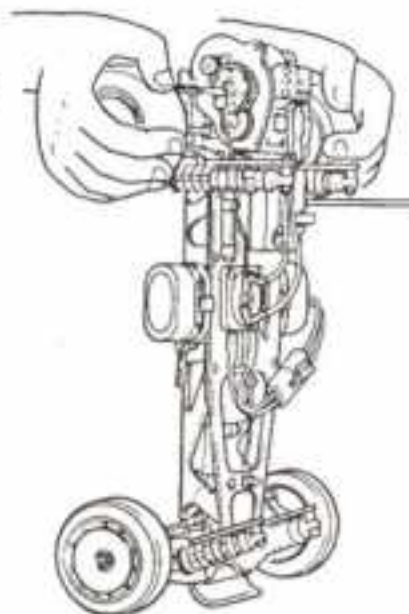

- 3 Swing the model car upward by holding the rear wheels. The best adjusted model will be raised to become horizontal and not farther.

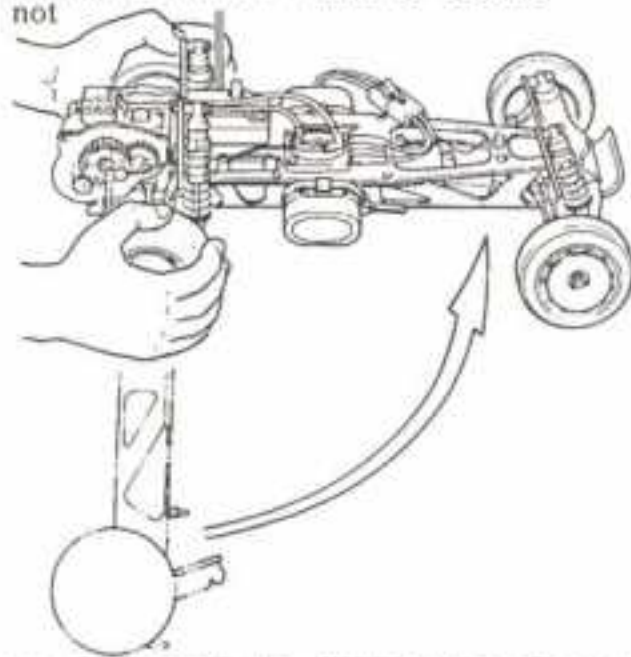

- 4 If the model goes up beyond the horizontal position, it indicates that the cap screw has been tightened excessively. Conversely if it does not reach to the horizontal line, tightening of the cap screw is inadequate. In such a case remove the flat headed screw which is fastening the rear hub and readjust the cap screw as shown. (During this procedure, hold the right side wheel to lock the shaft.)

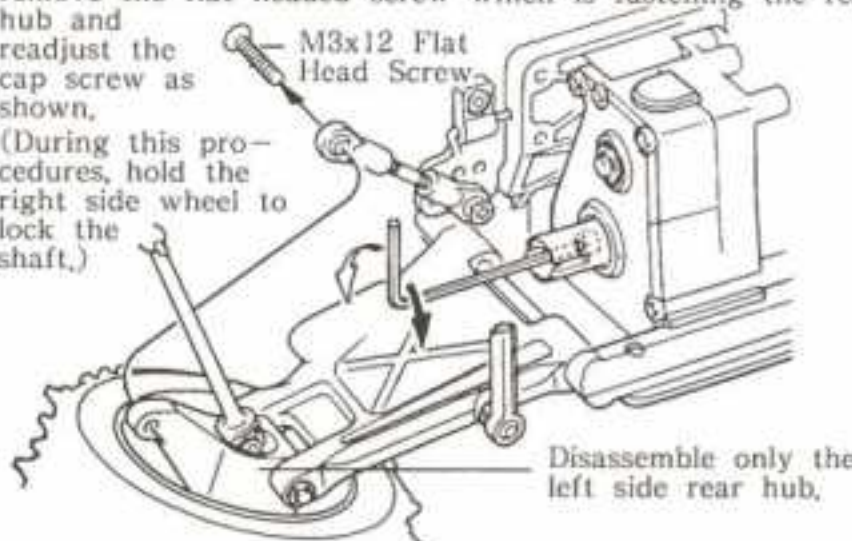

GUIDE FOR CHARACTERIZING MODEL (2)

[Fundamental Adjustment]

Place the car on a flat surface and keep the car with the highest clearance, and check to see if the wheels are positioned at a right angle to the ground. If necessary, adjust the front and rear upper rods.

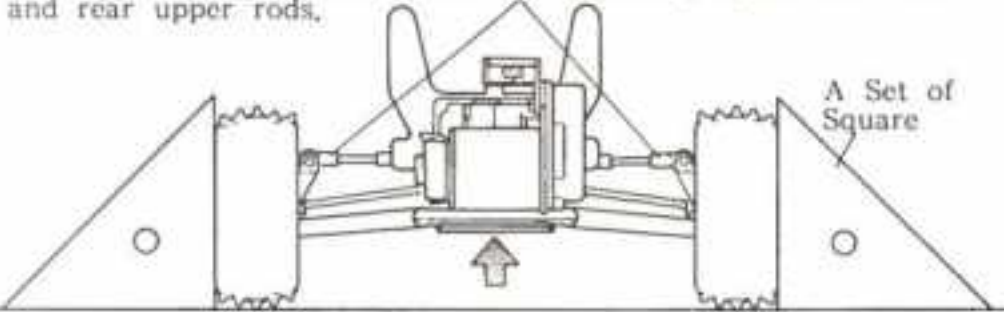

- By shortening the upper rods, you will have a negative camber angle. With a negative camber angle to the front wheels, you will have sharper steering response. With a negative camber angle to the rear wheels, you will have more traction on the rear.

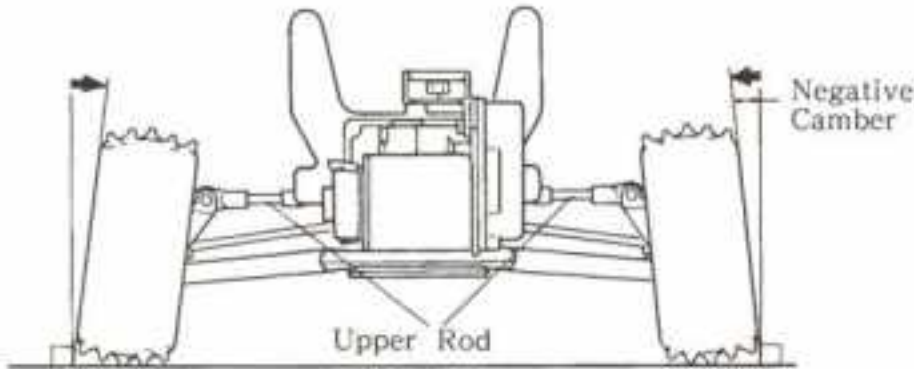

- By lengthening the upper rods, you will have a positive camber angle. With a positive camber angle to the front wheels, you will have an under-steering trait. With a positive camber angle to the rear wheels, you will have an over-steering trait.

* With an excessive positive camber angle adjustment, the universal swing shaft will be sometimes dislocated.

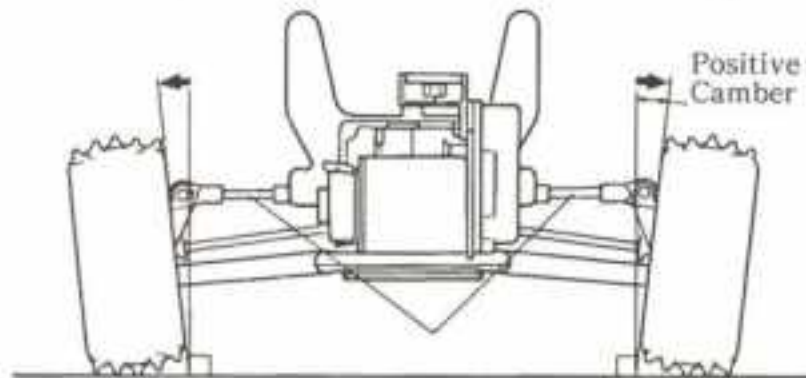

[Adjustment of Shock Oil and Spring]

- | | | |
|-------|--|----------------------------|
| Front | (With lighter shock oil
With weaker spring tension) | Sharper steering response. |
| Front | (With heavier shock oil
With stronger spring tension) | Slower steering response. |
| Rear | (With lighter shock oil
With weaker spring tension) | More wheel traction |
| Rear | (With heavier shock oil
With stronger spring tension) | Less wheel traction. |

*The above is just for a general indication.

[Adjustment of Suspension Spring]

- | | |
|--|---|
| 1 In the case of adjusting the spring stopper. | 2 In the case of adjusting the spring spacer. |
|--|---|

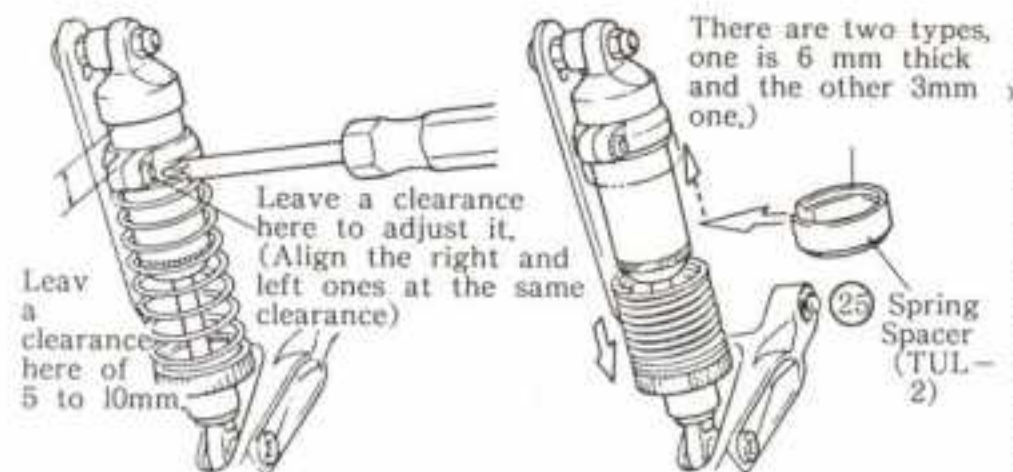

[Relation between the Installing position of the front Upper Rod and Camber Angle Adjustment]

When installing the upper rod to A position on the front shock stay, the camber angle is positioned to A adjustment at the lowest point of the front suspension systems; likewise B to B and C to C. In conclusion by changing the connecting points from A to B to C, more camber angles are realized.

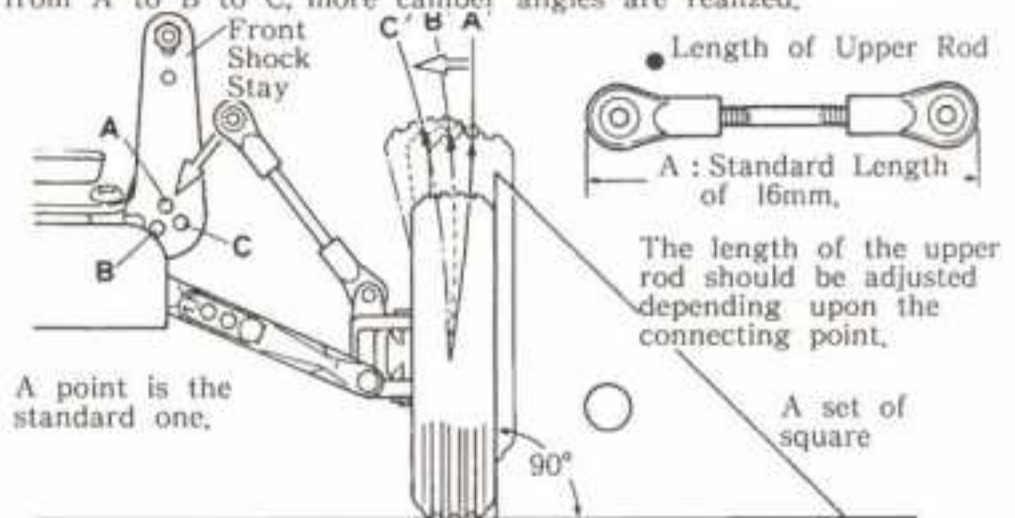

[Relation between the Installing Position of the Rear Upper Rod and Camber Angle Adjustment]

If you connect the upper rod to A point on the rear shock stay A is the maximum camber angle when the rear suspension systems sink most. At B point, B angle is achieved; that is, from A to B direction, the camber angle is augmented.

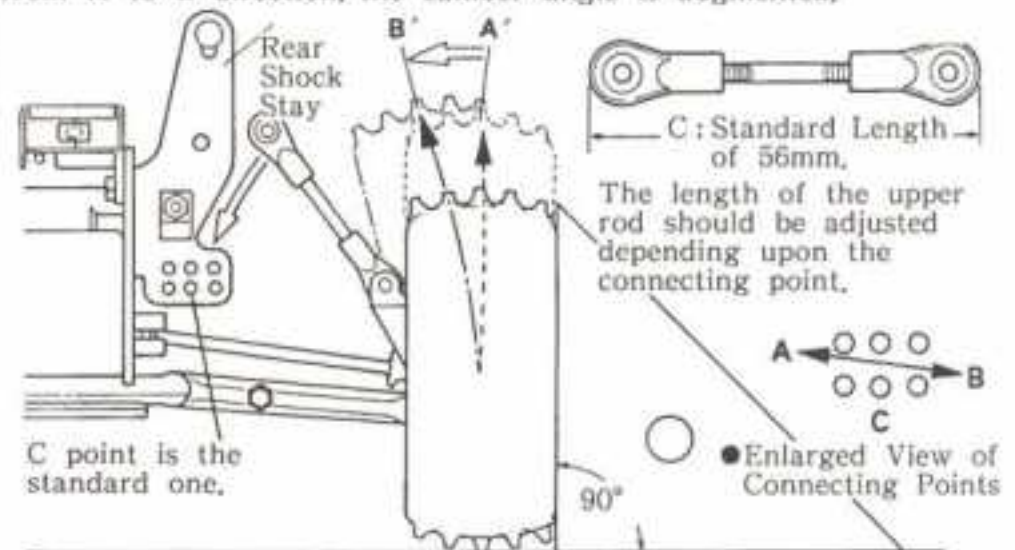

[Optional Racing Clutch]

This is a centrifugal clutch for the electric buggy car, it also functions as a torque limiter. It provides you an easy control on the slipper road surface. At the same time the device protects the motor and gears from impacts.

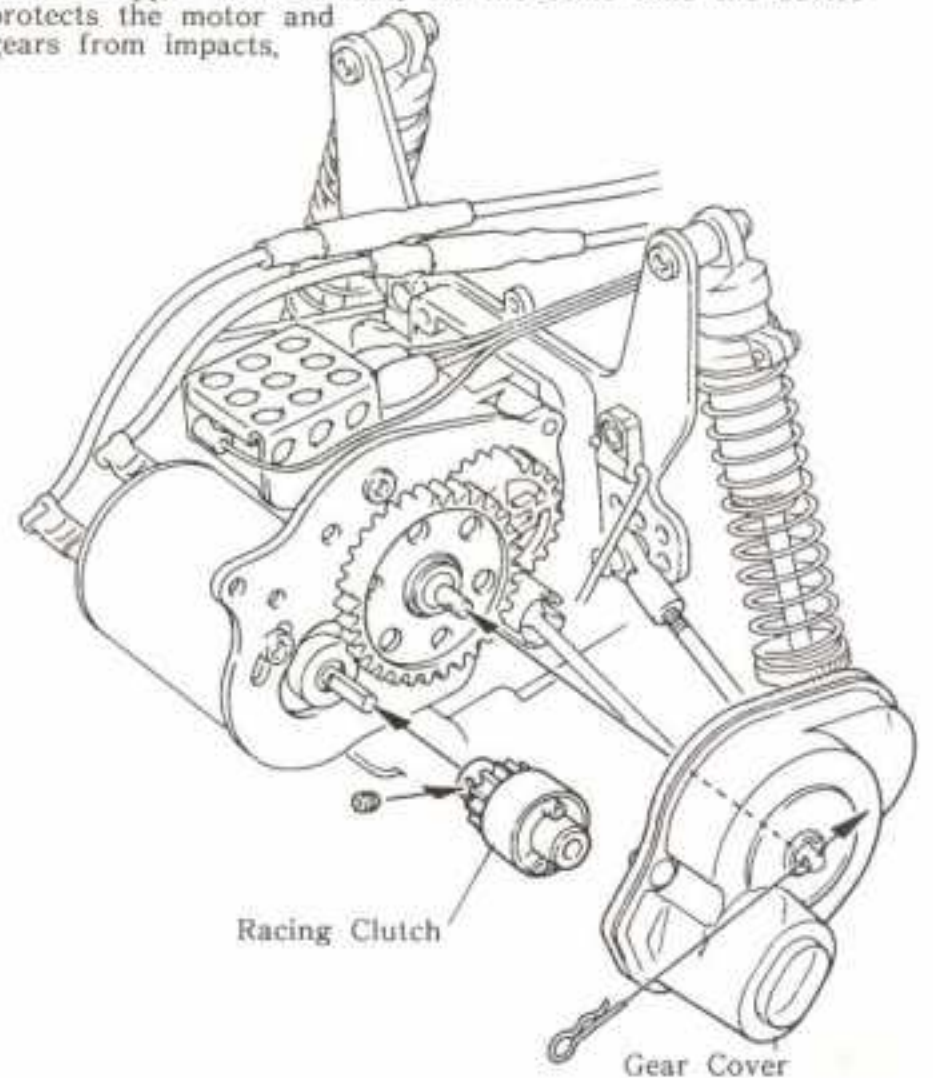

*There are five types of the racing clutch available. Refer to the optional parts list in the article of "When you lose or shock a part" on page 20.

EXPLODED VIEW OF BALL DIFFERENTIAL AND OIL SHOCK

[BALL DIFFERENTIAL]

● BALL DIFFERENTIAL

Refer to step 3 gearbox assembly and if there is any extra play insert 1 or 2 $\phi 8 \times 12$ shims to arrow area to make necessary adjustment.

Key #	Parts Name	Q'ty
Ⓐ	Diff. Shaft (B)	1
Ⓑ	8 ϕ x14 Bearing	2
Ⓒ	Presser Plate	2
Ⓓ	Diff. Ball	10
Ⓔ	Diff. Body	1
Ⓕ	Collar	1
Ⓖ	Diff. Shaft (A)	1
Ⓗ	Thrust Washer	2
Ⓘ	Thrust Ball	8
Ⓝ	Tapered Washer	5
Ⓚ	M2.6x15 Cap Screw	1
Ⓛ	8 ϕ x12 Adjustment Shim	2

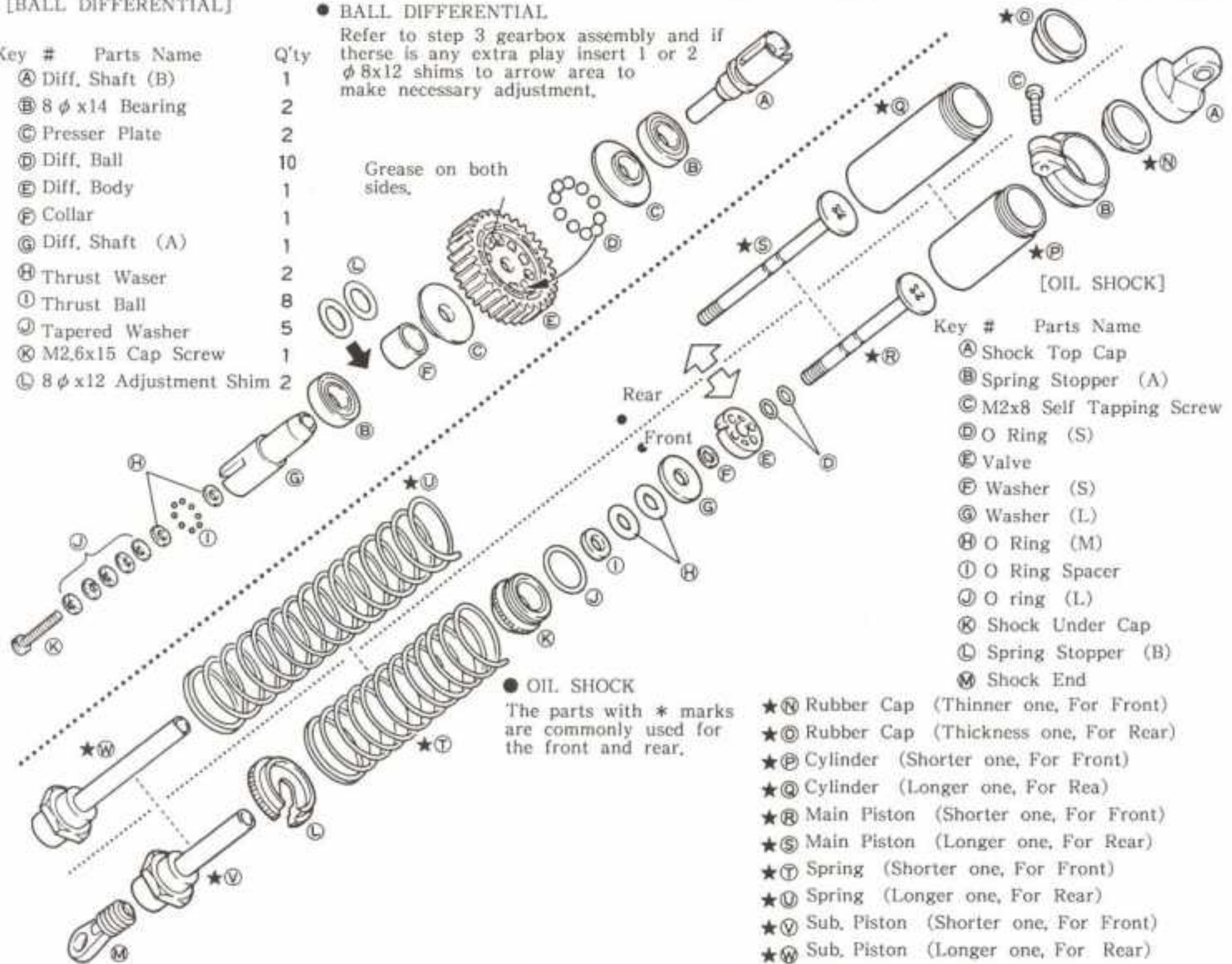

[OIL SHOCK]

Key #	Parts Name	Q'ty
Ⓐ	Shock Top Cap	4
Ⓑ	Spring Stopper (A)	4
Ⓒ	M2x8 Self Tapping Screw	4
Ⓓ	O Ring (S)	8
Ⓔ	Valve	4
Ⓕ	Washer (S)	4
Ⓖ	Washer (L)	4
Ⓗ	O Ring (M)	8
Ⓘ	O Ring Spacer	4
Ⓝ	O ring (L)	4
Ⓚ	Shock Under Cap	4
Ⓛ	Spring Stopper (B)	4
Ⓜ	Shock End	4
★Ⓝ	Rubber Cap (Thinner one, For Front)	2
★Ⓓ	Rubber Cap (Thickness one, For Rear)	2
★Ⓖ	Cylinder (Shorter one, For Front)	2
★Ⓝ	Cylinder (Longer one, For Rear)	2
★Ⓚ	Main Piston (Shorter one, For Front)	2
★Ⓛ	Main Piston (Longer one, For Rear)	2
★Ⓜ	Spring (Shorter one, For Front)	2
★Ⓝ	Spring (Longer one, For Rear)	2
★Ⓟ	Sub. Piston (Shorter one, For Front)	2
★Ⓠ	Sub. Piston (Longer one, For Rear)	2

● OIL SHOCK

The parts with * marks are commonly used for the front and rear.

PARTS LIST

Key #	Parts Name	Q'ty	Key #	Parts Name	Q'ty	Key #	Parts Name	Q'ty	Key #	Parts Name	Q'ty
①	Main Frame	1	⑳	Front Wheel	2	③③	Sponge Cap	1	⑧⑨	Upper Rod	4
●②	Ball Differential	1	㉑	Final Pinion	1	③④	Front Suspension Arm	2	⑧⑩	Ball Nut	1
③	Univasal Swing Shaft	2	㉒	Pinion Gear (15T)	1	③⑤	Rear Suspension Arm	2	⑧⑪	5.8 ϕ Ball (Silver Color)	10
●④	Front Oil Shock	2	㉓	Center Gear Shaft	1	③⑥	Front Bulk Head	1	⑧⑫	4.8 ϕ Ball	3
●⑤	Rear Oil Shock	2	㉔	Drive Washer	2	③⑦	Rear Axle Stopper	1	⑧⑬	Suspension Shaft (D)	2
⑥	4 ϕ x8 Bearing	6	㉕	Counter Gear Shaft	1	③⑧	Rear Bulk Head	1	⑧⑭	King Pin	2
⑦	5 ϕ x10 Bearing	6	㉖	2 ϕ x11 Pin	1	③⑨	Gear Cover	1	⑧⑮	Steering Rod	1
⑧	Wing	1	㉗	Front Wheel Shaft	2	③⑩	Bumper	1	⑧⑯	Speed Control Rod	1
●⑨	Speed Control Unit	1 set	㉘	Servo Saver Shaft	2	③⑪	Front Hub	2	⑧⑰	Center Rod	1
⑩	Le Mans 240ST Motor	1	㉙	Wing Post	2	③⑫	Knuckle Arm (L)	1	⑧⑱	Battery Holder	2
⑪	Radio Plate	1	㉚	Wing Stopper	2	③⑬	Knuckle Arm (R)	1	⑧⑲	Body	1
⑫	Gearbox (L)	1	㉛	O Ring (P3)	1	③⑭	Rear Hub	2	⑧⑳	Rear Tire	2
⑬	Gearbox (R)	1	㉜	Center Gear Collar	1	③⑮	Gearbox Hatch	1	⑧㉑	Front Tire	2
⑭	Motor Cord	1 set	㉝	5.8 ϕ Ball (Black Color)	6	③⑯	Servo Saver (A)	1	⑧㉒	Decal	1
⑮	Wing Wire	1	㉞	Motor Plate	1	③⑰	Servo Saver (B)	1	⑧㉓	Shock Oil	1
⑯	Gear Cover Seal	1	㉟	Heat Sink (A)	1	③⑱	Servo Saver (C)	1	⑧㉔	E Ring (E2.5)	10
⑰	Double Sided Tape	1	㊱	Heat Sink (B)	1	③㉑	Servo Saver (D)	1	⑧㉕	E Ring (E3)	3
⑱	Strap (S)	2	㊲	Front Shock Stay	1	③㉒	Servo Saver Collar	2	⑧㉖	E Ring (E4)	2
㉑	Nicd Strap	2	㊳	Rear Shock Stay	1	③㉓	Servo Stay	4	⑧㉗	Hook Pin	2
㉒	Antenna Pipe	1	㊴	Front Stabilizer	1	③㉔	Body Hook	1	⑧㉘	Hex Key (1.5)	1
㉓	Stabilizer Link (L)	2	㊵	Rear Stabilizer	1	③㉕	Antenna Post	1	⑧㉙	Hex Key (2)	1
㉔	Stabilizer Link (S)	2	㊶	Suspension Shaft (B)	2	③㉖	Ball End (L)	12	⑧㉚	Body Pin	3
㉕	Stabilizer Stopper	2	㊷	Center Gear	1	③㉗	Ball End (S)	2			
★㉖	Shock collar	4	㊸	Counter Gear	1	③㉘	Sus. Shaft (C) (Silver)	2			
★㉗	Spring Spacer	4	㊹	Stabilizer Ball	2	③㉙	Sus. Shaft (A) (Black)	2			
㉘	Rear Wheel	2	㊺	Adjust Ball	4	③㉚	Tie Rod	2			

The parts with ● are assembled.

LIST OF PARTS & KEY NUMBERS (1)

1:10 TURBO ULTIMA BAGGED PART LIST

BLISTER

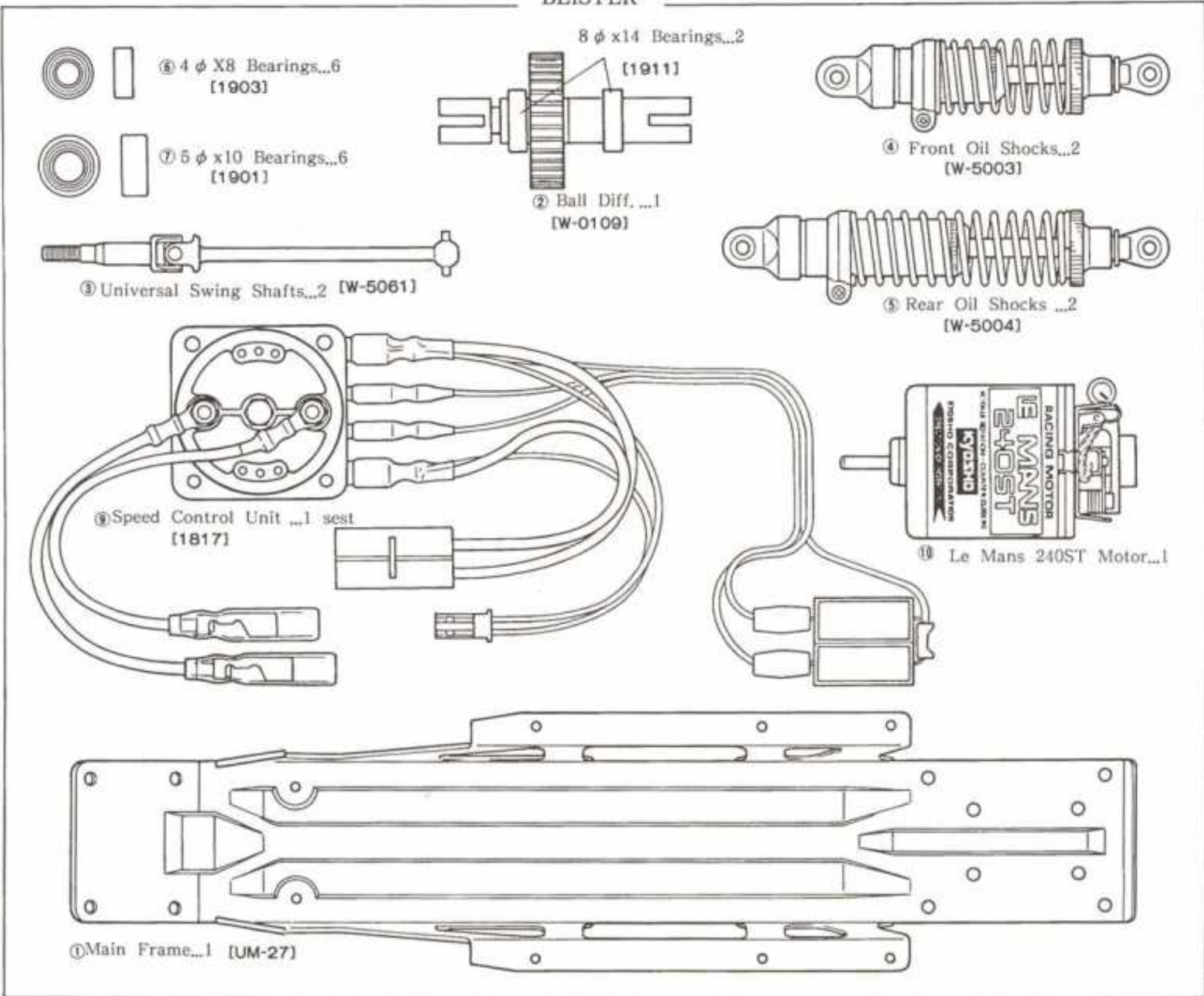

TUL-1

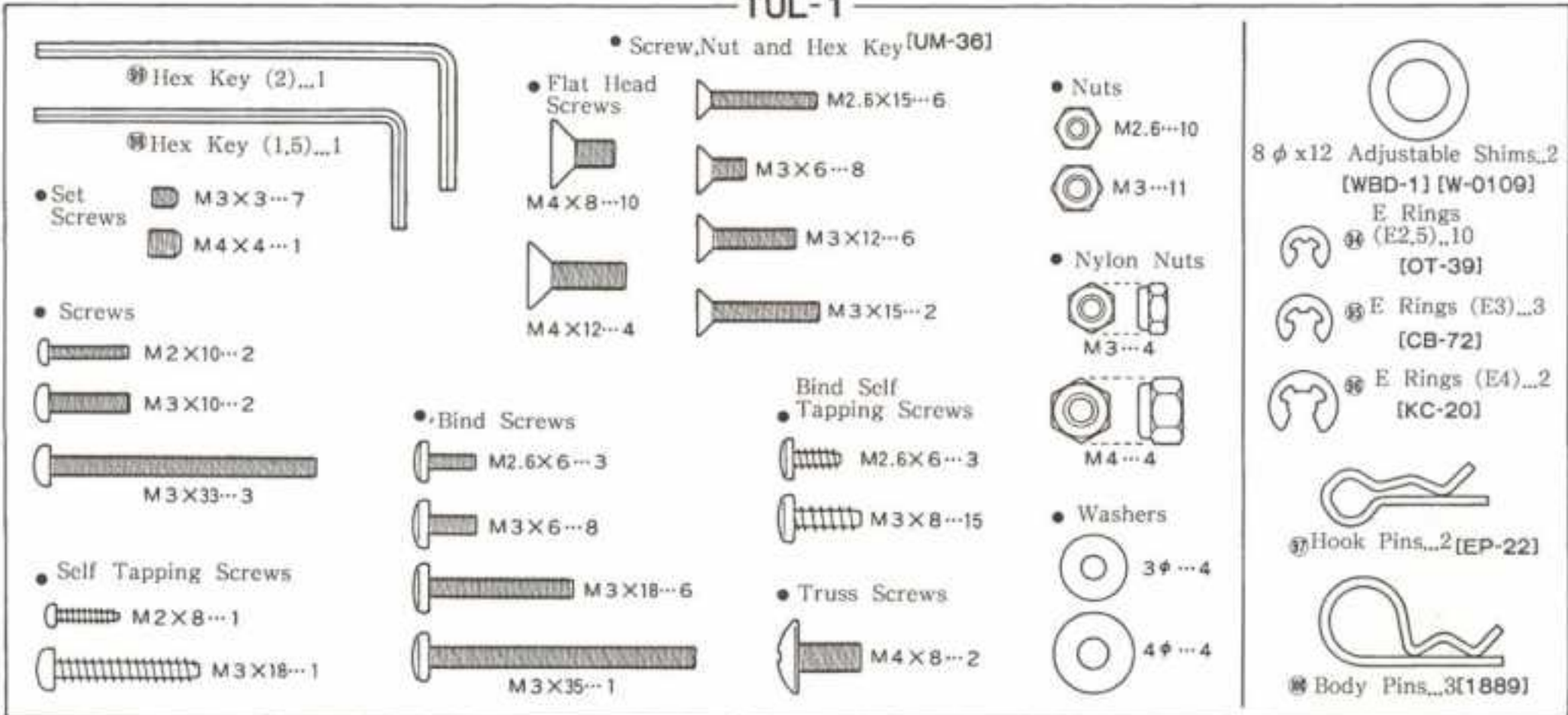

LIST OF PARTS & KEY NUMBERS (2)

TUL-2

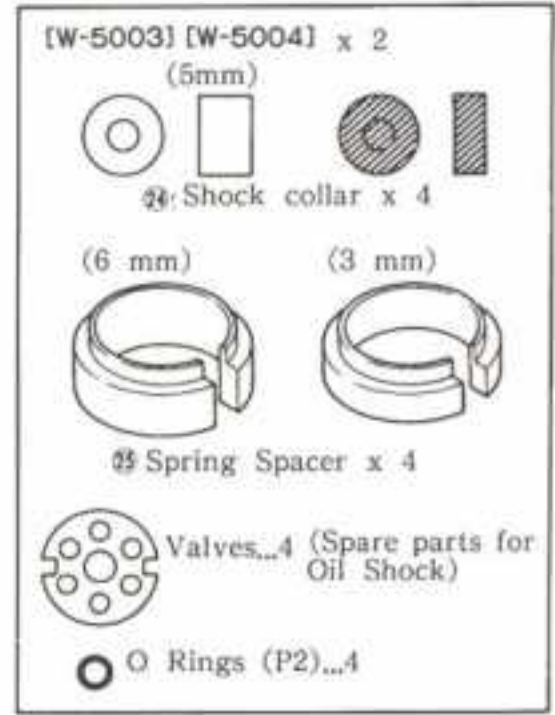
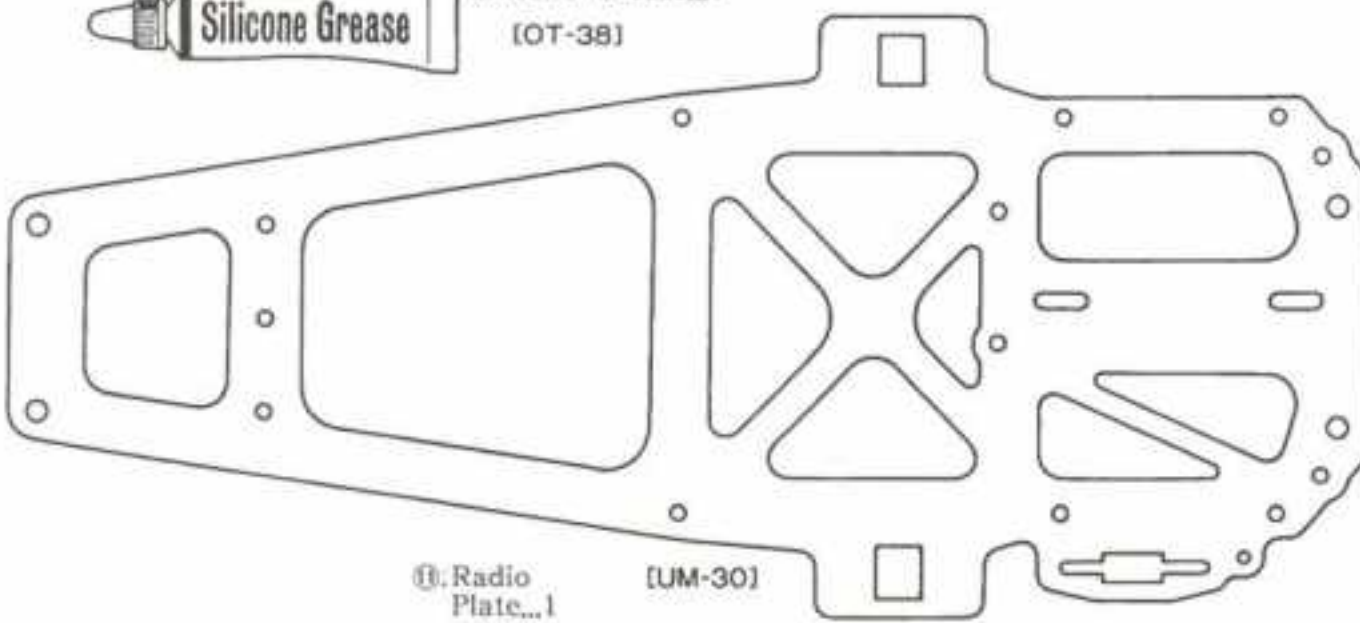
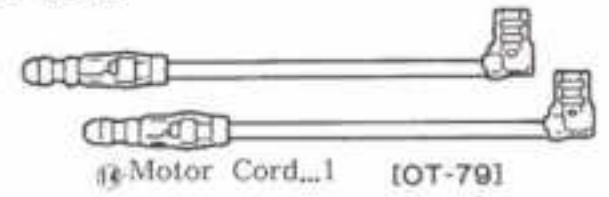
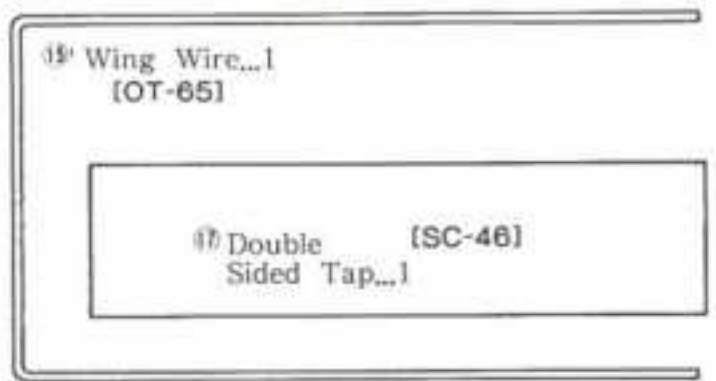
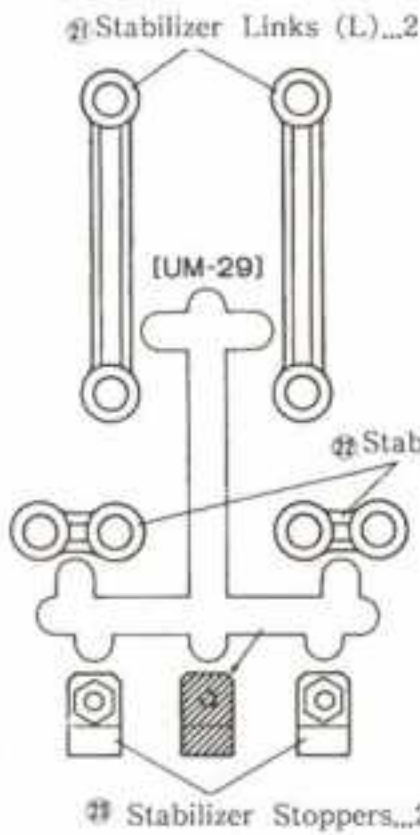
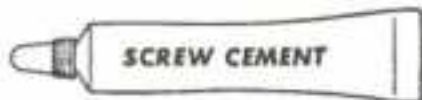
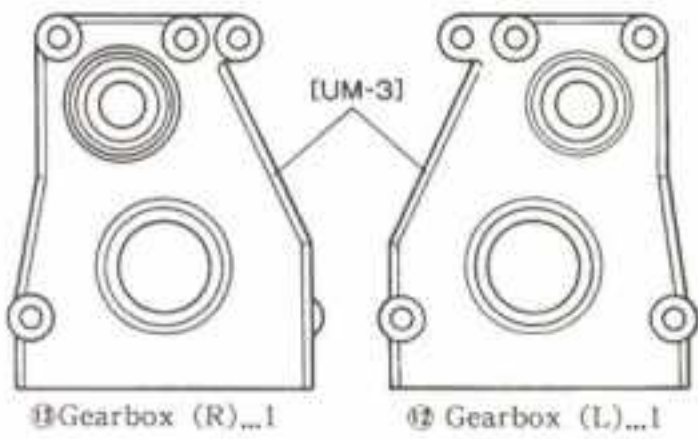

TUL-3

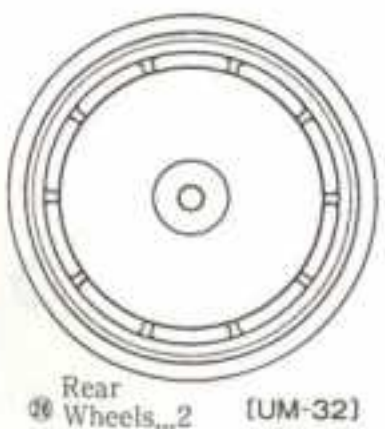

TUL-4

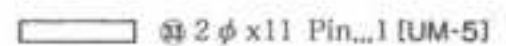
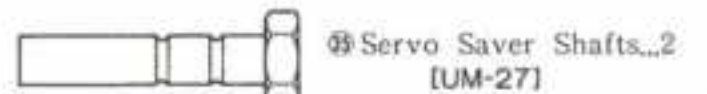
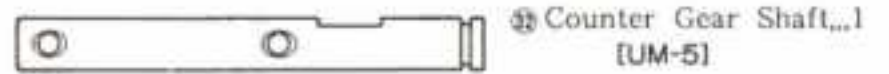
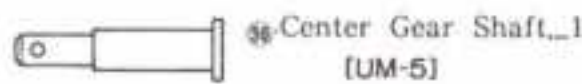
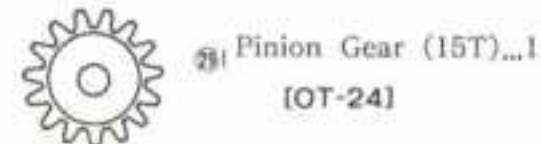
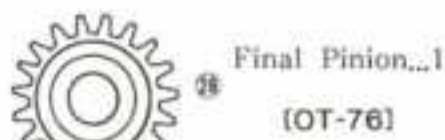

TUL-5

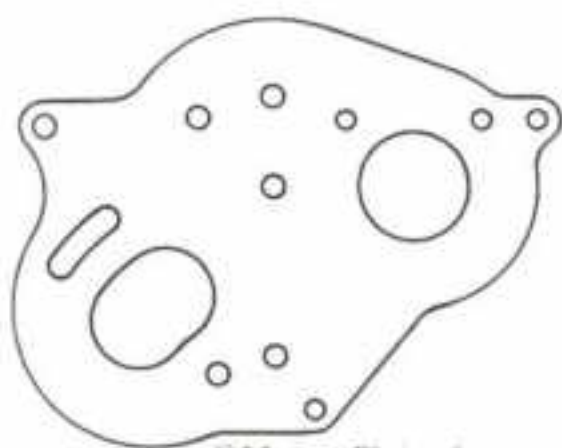

41 Motor Plate...1 [UM-4]

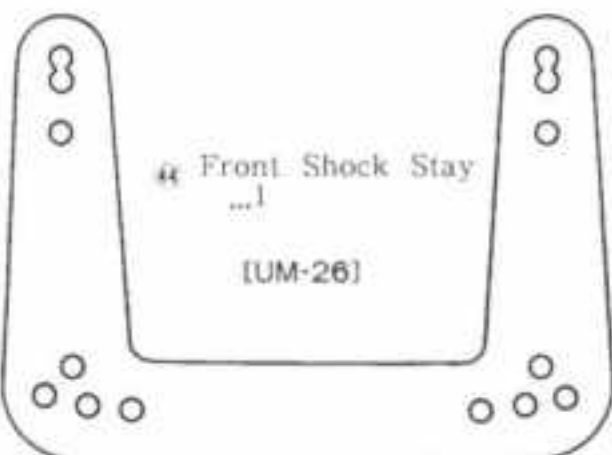

44 Front Shock Stay...1 [UM-26]

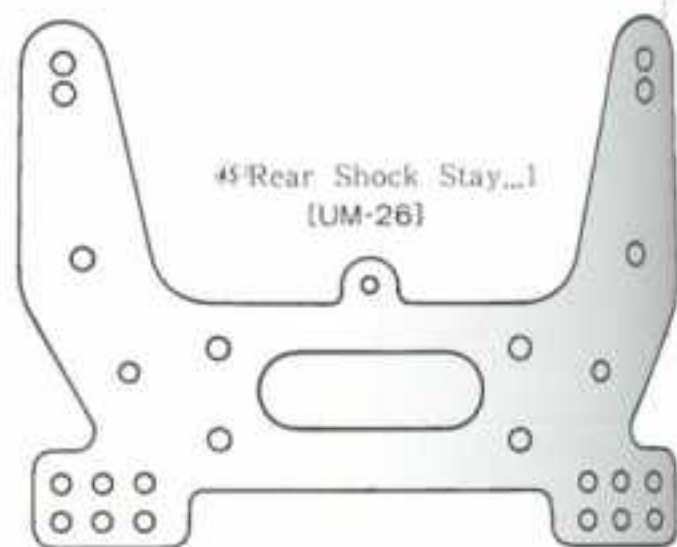

45 Rear Shock Stay...1 [UM-26]

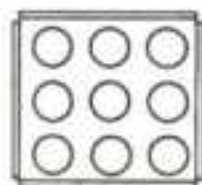

42 Heat Sink (A)...1 [OT-72]



46 Rear Stabilizer...1 [UM-29]

44 Front Stabilizer...1 [UM-29]



48 Sus. Shafts (B)...2 [UM-7]

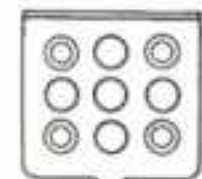

43 Heat Sink (B)...1 [OT-72]



47 Stabilizer Balls...2 [UM-29]



49 Adjust Balls...4 [UM-29]



59 Counter Gear...1 [UM-1]



48 Center Gear...1 [UM-1]



45 Sponge Cap...1 [W-0109]

TUL-6

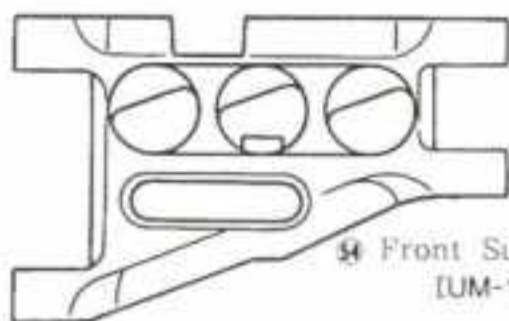

44 Front Sus. Arms...2 [UM-13]

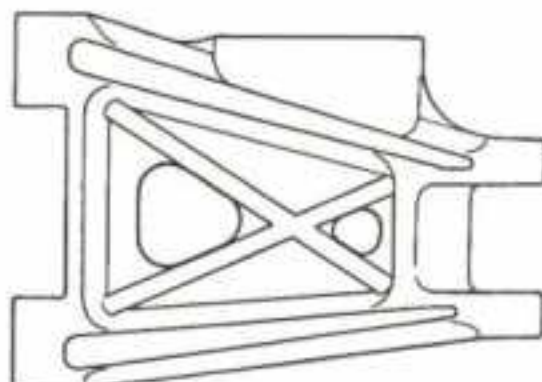

45 Rear Sus. Arms...2 [UM-13]

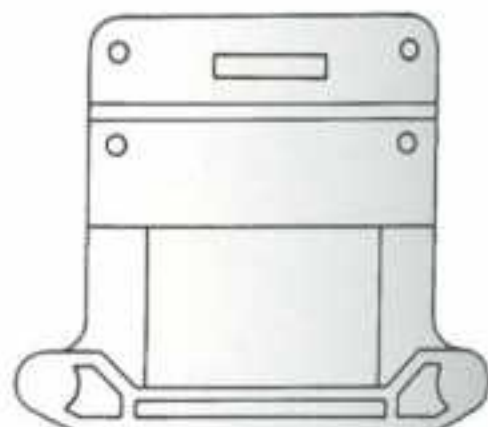

46 Rear Bulk Head...1 [UM-12]

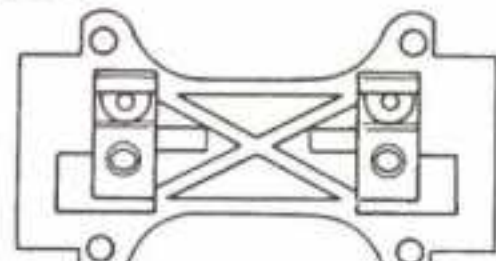

46 Front Bulk Head...1 [UM-12]

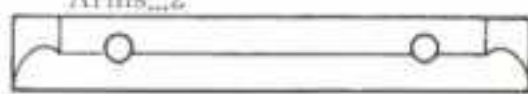

47 Rear Axle Stopper...1 [UM-12]



48 Bumper...1 [UM-21]

48 Servo Saver (C)...1

48 Servo Saver (A)...1

48 Servo Saver (D)...1

48 Gearbox Hatch...1

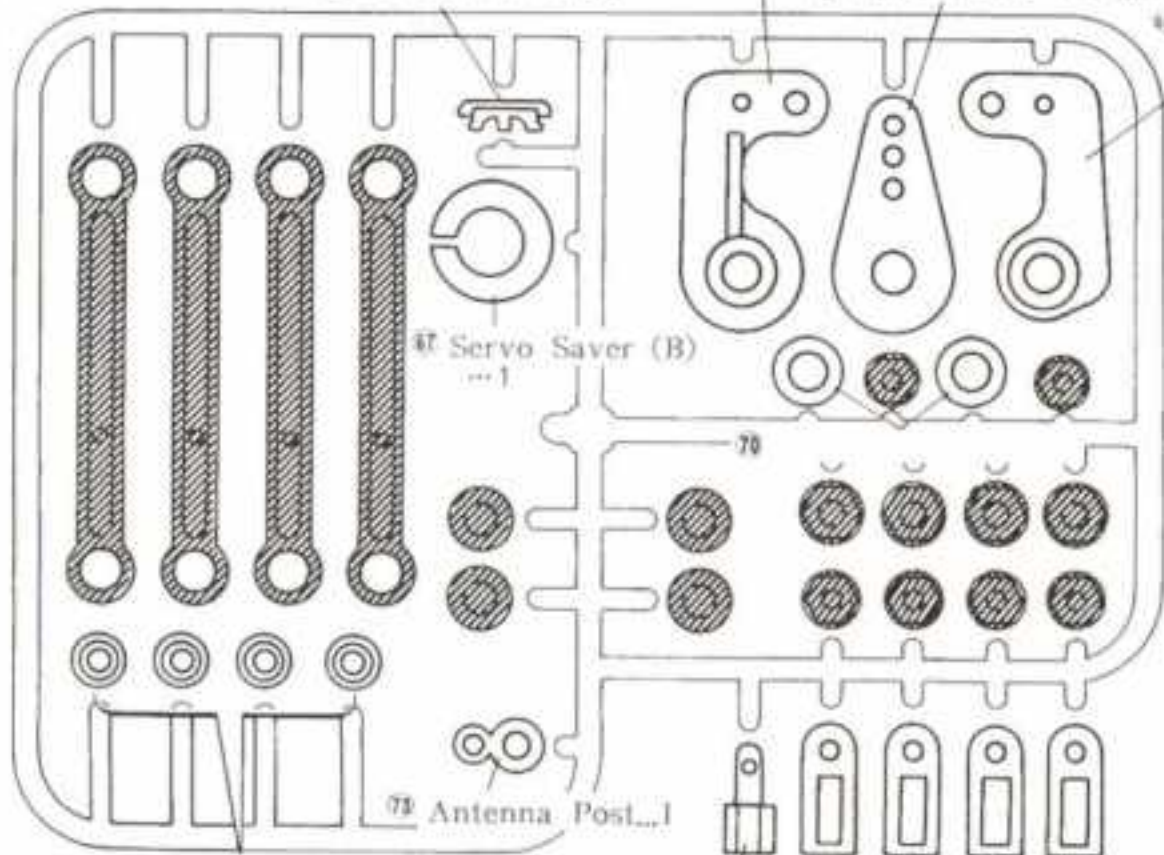

47 Servo Saver (B)...1

73 Antenna Post...1

70 Servo Stays...4

72 Body Hook...1

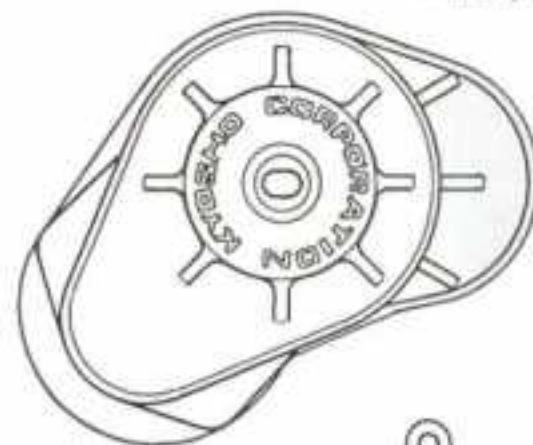

49 Gear Cover...1 [UM-12]



48 Rear Hubs...2 [UM-11]

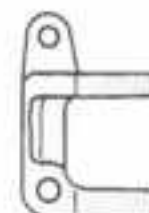

48 Front Hubs...2 [UM-11]















48 Knuckle Arm (R)...1 [UM-11]

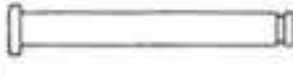

48 Knuckle Arm (L)...1 [UM-11]

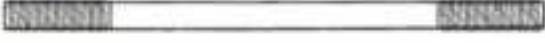
LIST OF PARTS & KEY NUMBERS (4)

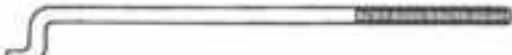
TUL-7

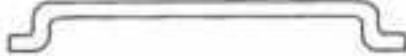
-  ④ Ball Ends (L) [OT-35]
...12 [SC-89]
-  ④ Ball Ends (S) [OT-35]
...2 [UM-9]
-  ⑧ Ball Nut...1 [OT-33]
-  ⑧ 5.8 φ Balls (Silver color)...10 [OT-32]
-  ⑧ 4.8 φ Balls [UM-29]
...3
-  ⑧ Battery Holders...2 [UM-27]
-  ④ King Pins...2 [UM-8]
-  ④ Sus. Shafts (C) (Silver color)...2 [UM-7]
-  ④ Sus. Shaft (A) (Black color)...2 [UM-7]
-  ④ Sus. Shafts (D)...2 [UM-7]
-  ④ Tie Rods...2 [SC-89]
-  ④ Upper Rods...4 [OT-35]
-  ④ Steering Rod...1 [UM-9]
-  ④ Speed Control Rod ...1 [UM-9]
-  ④ Center Rod...1 [UM-9]

⑧ Wing...1 [OT-107]

⑧ Decal...1 [UM-35]

⑧ Body...1 [UM-34]

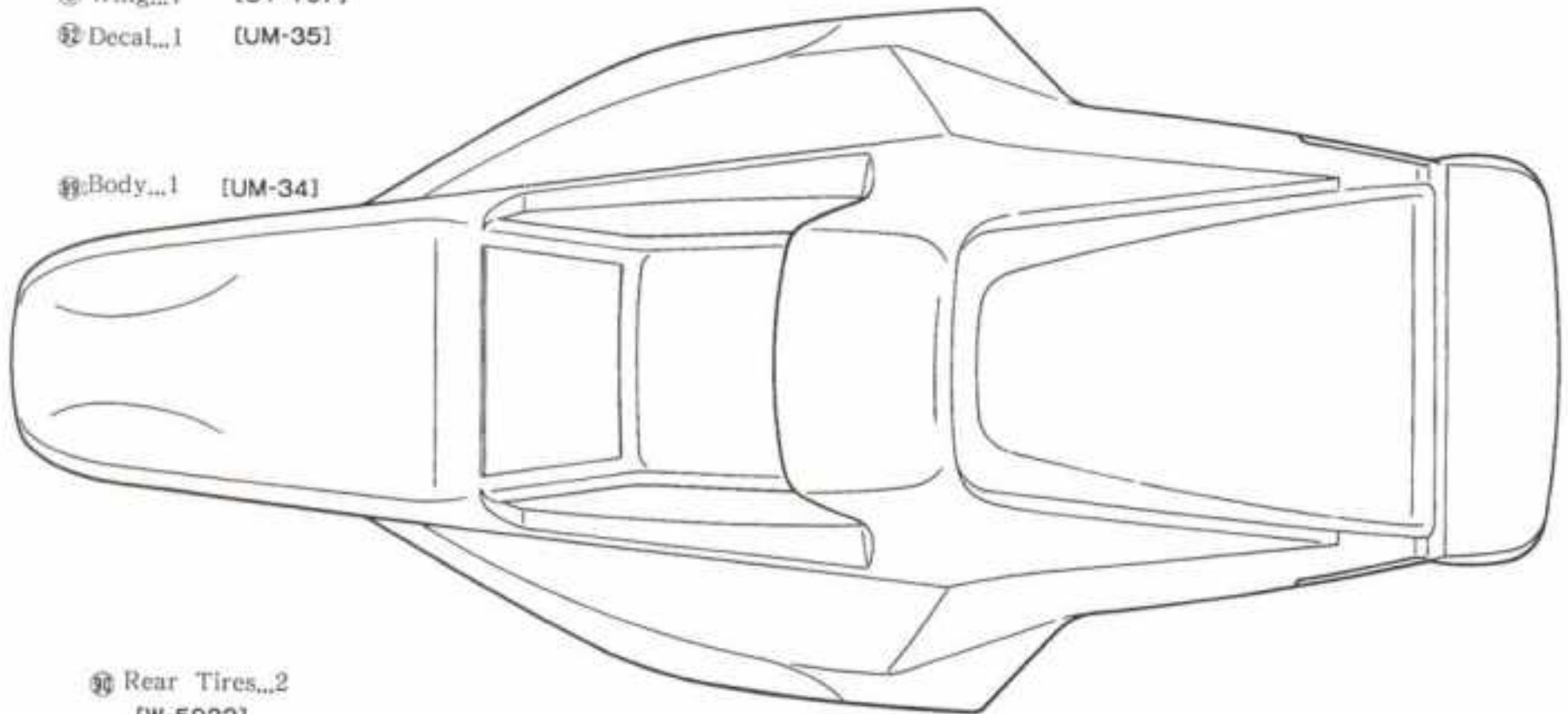

⑧ Rear Tires...2 [W-5032]

⑧ Front Tires...2 [SC-26]



The Super Hobby



PARTS LIST

You can purchase replacement and optional parts for your kit. We offer these parts in convenient "parts packs" which can be purchased anywhere Kyosho kits are sold. Note that parts are not sold separately but are available within a Parts Pack. When referring to the parts pack you need, always use the Kyosho Pack Number. For instance, if you need wing, ask your dealer for Kyosho Parts Pack OT-107.

Key #	Parts Name	Consisting of
OT-19	Drive Washer	① × 4
OT-24	Pinion Gear (15T)	② × 1
OT-29	O Ring	③ × 10
OT-32	5.8 φ Ball	④ × 10
OT-33	Ball Nut (M2,6)	⑤ × 10
OT-35	upper Rod Set	⑥ ⑦ × 4 ⑧ × 8
OT-39	E Ring (E2,5)	⑨ × 10
OT-65	Wing Stay Set	⑩ × 1 ⑪ ⑫ × 2
OT-72	Resistor Heat Sink	⑬ ⑭ × 1
OT-76	Hard Final Pinion Gear	⑮ × 1
OT-79	Cord Set	⑯ × 1 set
OT-101	5.8 φ Ball (Black 2.6 φ hole)	⑰ × 10
OT-107	Wing	⑱ × 1
UM-1	Gear Set	⑲ ⑳ × 1 Others × 3
UM-3	Gearbox	㉑ ㉒ × 1
UM-4	Motor Plate	㉓ × 1
UM-5	Gear Shaft Set	㉔ ㉕ × 1 ㉖ × 2
UM-7	Sus. Shaft Set	㉗ ㉘ ㉙ ㉚ × 2
UM-8	Front Shaft Set	㉛ ㉜ × 2
UM-9	Rod Set	㉝ × 2 ㉞ ㉟ ㊱ × 1 Others × 2
UM-11	Upright Set	㊲ ㊳ × 1 ㊴ ㊵ × 2
UM-12	Bulk Head Set	㊶ ㊷ ㊸ ㊹ ㊺ × 1
UM-13	Sus. Arm Set	㊻ ㊼ × 2
UM-14	Servo Saver Set	㊽ ㊾ ㊿ ① ② ③ ④ × 1 ⑤ × 2 ⑥ × 4 Others × 16
UM-21	Front Bumper	⑦ × 1
UM-26	Special Shock Stay	⑧ ⑨ × 1
UM-27	Special Chassis	⑩ × 1 ⑪ ⑫ × 2
UM-29	Stabilizer Set	⑬ ⑭ ⑮ ⑯ ⑰ × 2 ⑱ ⑲ × 1 ㉑ × 4
UM-30	Special Radio Plate	㉒ × 1
UM-32	Rear Wheel	㉓ × 2
UM-33	Front Wheel	㉔ × 2
UM-34	Body	㉕ × 1
UM-35	Decal	㉖ × 1
UM-36	Screw Set	Screw Nut Wrench Set
W-0109	Ball Diff.	㉗ × 1 ㉘ × 1
W-5003	Adjustable Oil Shock (S)	㉙ ㉚ ㉛ × 2
W-5004	Adjustable Oil Shock (L)	㉜ ㉝ ㉞ × 2
W-5032	Low Profile Tire (Soft)	㉟ × 2
W-5061	Universal Wing Shaft	① × 2
SC-26	Front Tire	② × 2
SC-46	Double Sided Tape	③ × 1
SC-89	Tie Rod	④ × 2 ⑤ ⑥ × 4
EP-22	Hook Pin	⑦ × 5
EP-37	Strap (S)	⑧ × 6
EP-39	Nick Strap	⑨ × 6
SD-79	Antenna Pipe	⑩ × 5
CB-72	E Ring (E3)	⑪ × 4
KC-20	E Ring (E4)	⑫ × 4
1817	Rotary Controller	⑬ × 1 set
1889	Body Pin	⑭ × 5
1901	Ball Bearing (5 φ x10)	⑮ × 2
1903	Ball Bearing (4 φ x8)	⑯ × 2

Key #	Parts Name	Consisting of
Optional Parts		
UM-17	Wheel Set	
UM-23	Pinion Gear (18T)	
UM-24	Pinion Gear (19T)	
UM-25	Pinion Gear (20T)	
UM-28	Motor Guard	
OT-23	Pinion Gear (12T)	
OT-24	Pinion Gear (15T)	
OT-38	Silicon Grease	2g x 2
OT-50	Pinion Gear (13T)	
OT-51	Pinion Gear (14T)	
OT-52	Pinion Gear (16T)	
OT-53	Pinion Gear (17T)	
OT-66	Low Profile Tire (Pin Type)	Pin Spike Rear Tire x 2
OT-67	Wheel for Low Profile tire	3 Piece Type x 2
OT-90	Wheel for Low Profile Tire	1 Piece Type x 4
EF-103	Racing Wire	4 φ Silicon Cord
LM-15	Motor Ring Plate	Cooling Plate for Le Mans Motor
SC-90	Front Tire	For Soft Surface Track
RK-15	Low Profile Tire	Rear Tire x 2
1863	Sponsor Sticker	
1871	Sponge Tire (A)	For Front & Low profile Wheel
1883	Frontia Hobby Oil	30cc
1953	Silicon Oil (S)	Does not change density against temperature change.
1954	Silicon Oil (M)	"
1955	Silicon Oil (H)	"
1990	Regulator	Stable Power Supply for RX.
W-5001	Pressure Shock (S)	High Efficiency 12 φ Shocks
W-5002	Pressure Shock (L)	"
W-5005	Special Rod Set	One Touch Adjustment
W-5009	Hard Pinion Gear (9T)	
W-5010	Hard Pinion Gear (10T)	
W-5011	Hard Pinion Gear (11T)	
W-5021	Large Size Wheel	For Rear Tire, Silver
W-5032	Low Profile Tire High Grip	
W-5033	Narrow Tire (Pin Type)	Used for front/rear, 2pcs.
W-5034	Narrow Tire (Hard Surface)	
W-5040	Racing Clutch (19T)	
W-5042	Racing Clutch (12T)	
W-5044	Racing Clutch (14T)	
W-5046	Racing Clutch (16T)	
W-5048	Racing Clutch (18&)	
1911	Ball Bearing (8 φ x14)	2
1951	Shock Oil Set (S,M,H)	3 different weight.
1974	Bearing Set for Ultima	① ② 6 8 φ x14 x2
WBD-1	Ball Diff. Shaft Plat Set	③ ④ ⑤ 1 ⑥ ⑦ 2 1
WBD-2	Ball Diff Ball Set	⑧ ⑨ 12 ⑩ x2 ⑪ x10 ⑫ ⑬ 1
WBD-3	Ball Diff. Body	⑭ x1



THINGS TO OBSERVE

KYOSHO ASKS YOU TO ABIDE BY THE FOLLOWING POINTS IN ORDER TO RUN YOUR MODEL SAFELY: THE PROPER HANDLING ONLY CAN BRING OUT ITS CAPABILITY TO THE FULL; SO READ THE INSTRUCTION CAREFULLY BEFORE ENJOYING THE RADIO CONTROLLED MODEL WORLD.

● CHECKING ALL POINTS

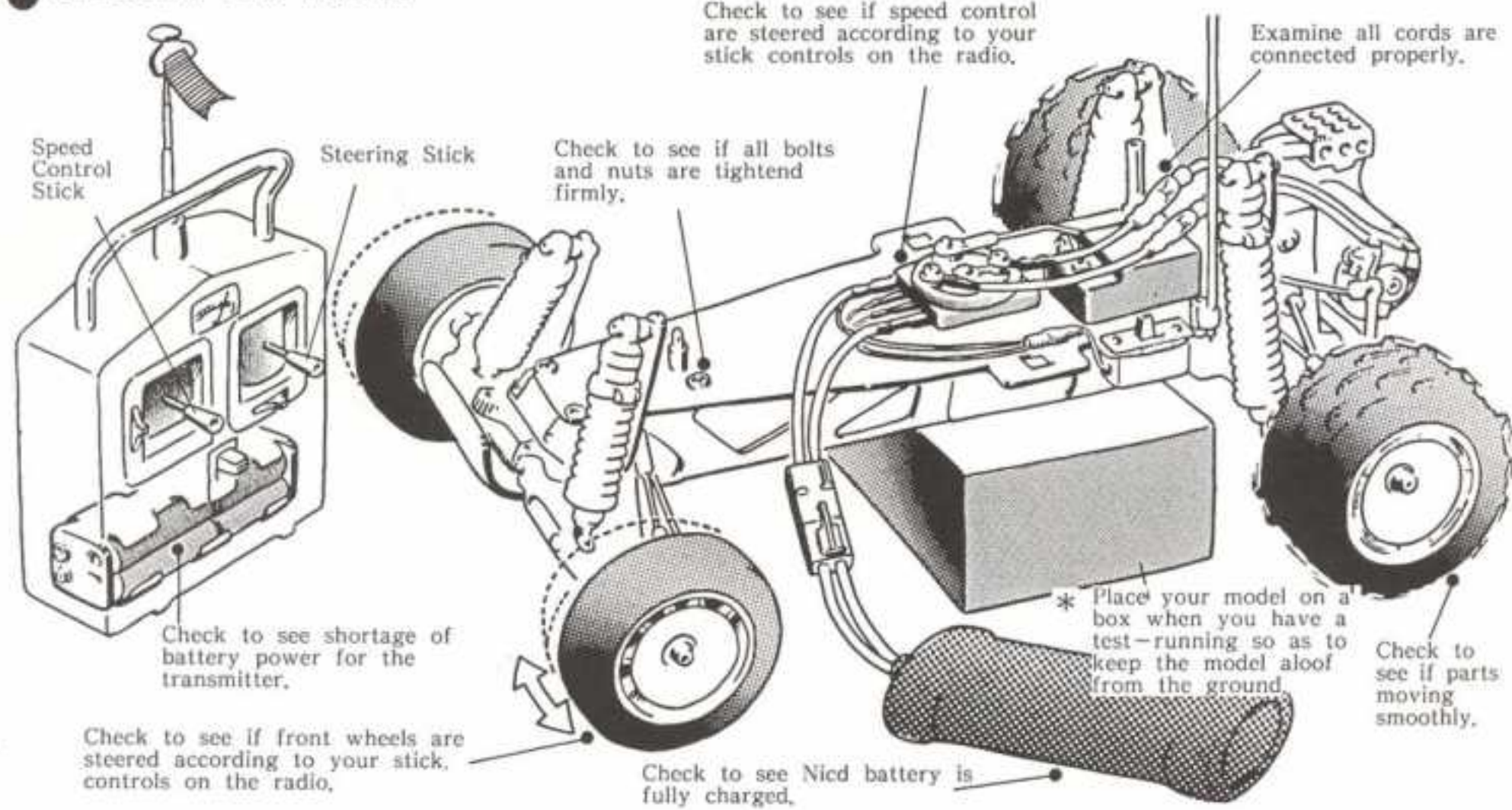

● WHEN CONNECTING THE NICD BATTERY

Before connecting the Nicd battery, confirm that the speed controller is positioned in neutral.

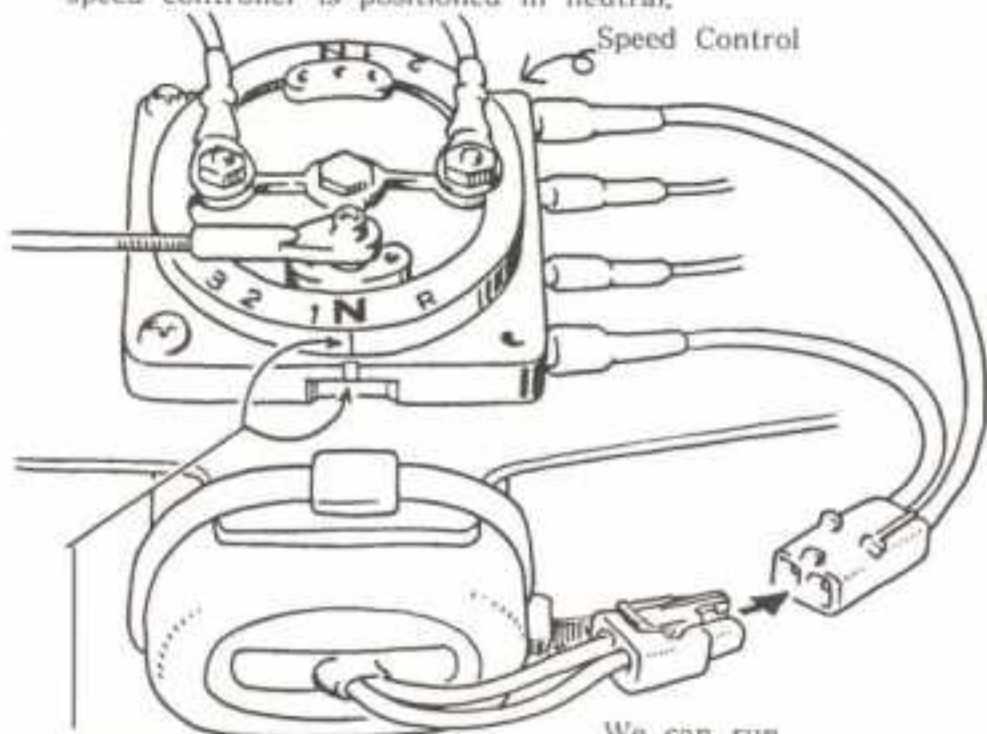

● WHEN YOU HAVE TWO CARS OR MORE RUN TOGETHER

Two cars under the same frequency cannot run at a time. When there is another model going in the same time, compare the frequency of your radio with his.

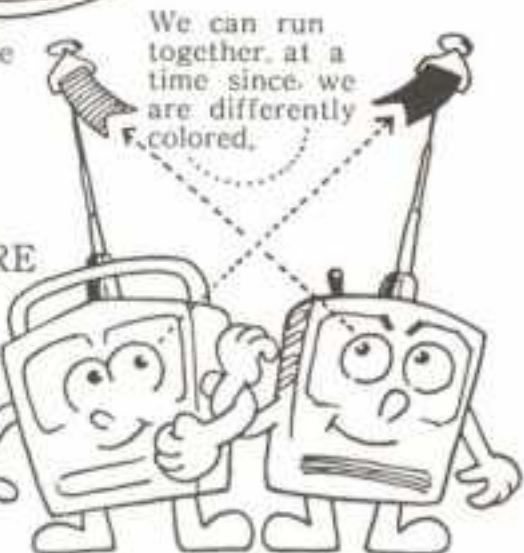

● PLACES YOU MUST NOT RUN YOUR MODEL

The electric R/C model car is powered by a powerful Nicd battery, so it may run at a faster speed than you expect it.



Under any circumstances, do not run your model in the rain or through a puddle. Water penetrated into the receiver, switch or servos may cause a trouble.



BEFORE RUNNING

↑ RUNNING ↓
 ↓ AFTER RUNNING ↓

BREAK-IN RUNNING

When you have your car run for the first time, drive it slowly while it uses up one to three charges of the battery pack.

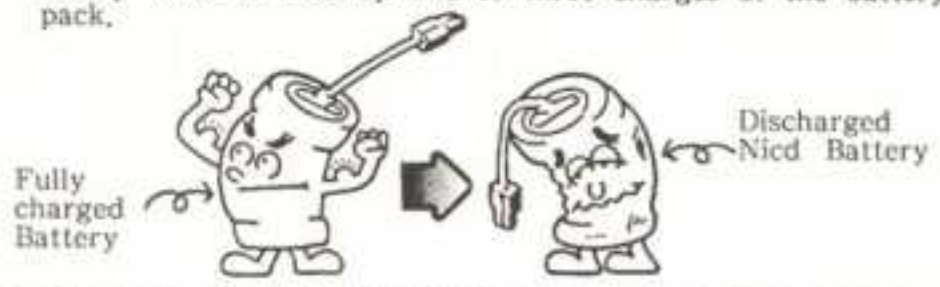

SEQUENCE OF SWITCHING ON WHEN YOU RUN YOUR MODEL

First turn on the switch of the transmitter, then that of the receiver. Remember it is from the transmitter to the receiver. If you don't keep this sequence, the car may start to run haphazardly or the resistor may generate heat excessively.



RESISTOR

The low speed and medium speed are realized by increasing resistance of the speed controller. So after keeping the car run in that condition for a while, do not touch the speed controller since it is very hot.

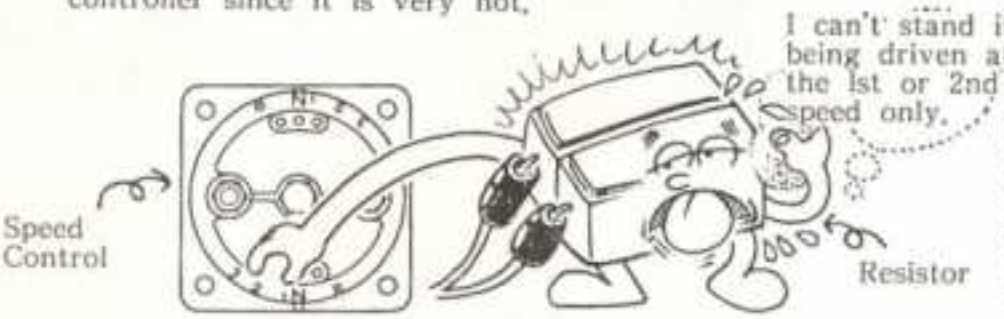

A CAR WITHOUT BATTERY BOX FOR RECEIVER

Some model cars have the only battery pack to drive the motor and to power the receiver. With such a type of cars, you cannot keep it running when the power in the battery decreases to some extent and electricity does not flow into the receiver. Whenever you notice your car beginning to lose speed, stop your operation.



WHEN A CAR STALLS SUDDENLY

Don't drive it by force. Otherwise, The heat generated by the motor or wiring may melt or damage some parts.



SEQUENCE OF TURNING OFF THE SWITCH

Switch off the receiver first, then that of the transmitter. In a word, It is the topsy-turvy proceeding of what when you start a car

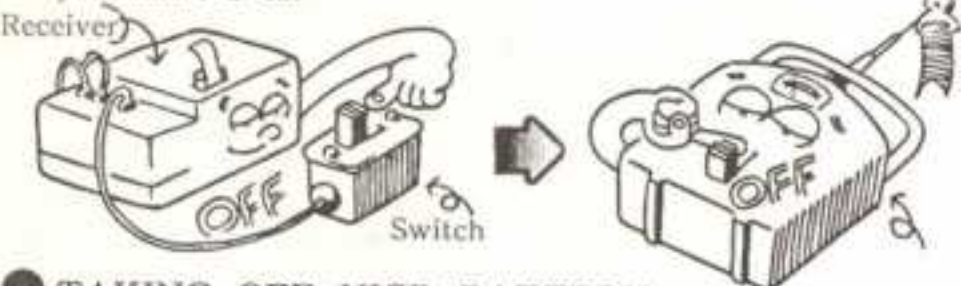

TAKING OFF NICD BATTERY

You must unplug the connectors of the Nicd battery pack and store it separately.

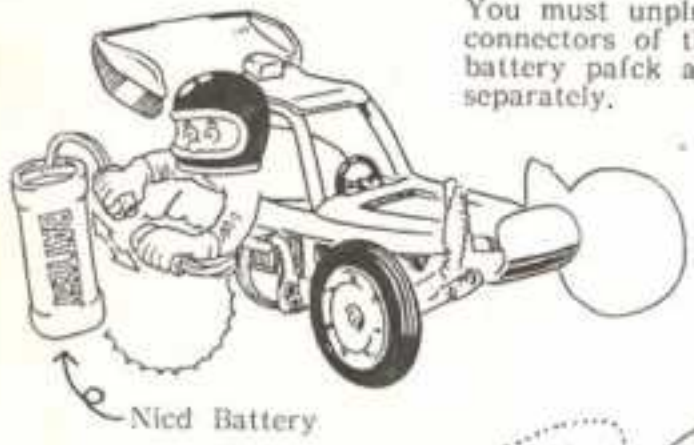

MAINTENANCE AFTER A RUNNING

Wipe off stains from the motor, gears, and chassis, in order to make them prepared for the next operation.



TAKING CARE OF MOTOR AFTER A RUN

The motor becomes hot after each run. So continuous running may shorten its life. Do not run the car until the motor gets cool after each operation. Depending upon a running condition, the resistor may generate heat. Do not touch it right after a run.



After several runs the motor may lose its power. This is because of carbon accumulated on the commutator of motor. In such a case, remove the pinion gear and run it idly for 15 minutes.

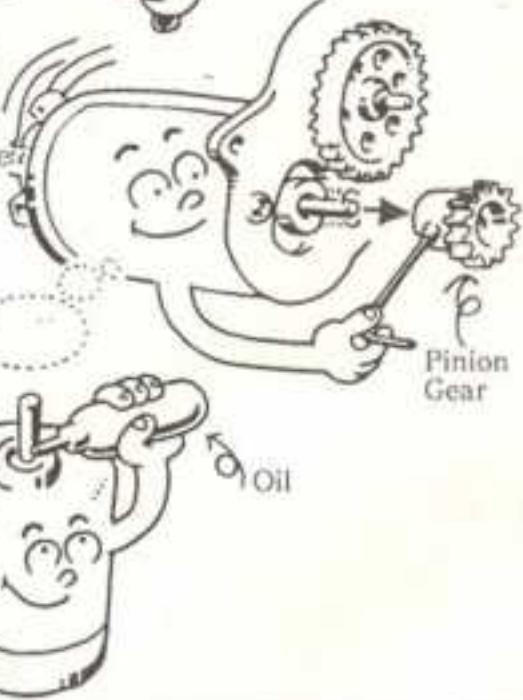

OFF-ROAD RACER "TURBO ULTIMA"

(Spare parts List)

KIT No. 3116



Parts No.	Description	Contents	Quantity
OT-19	Drive Washer	① × 4 pcs.	
OT-24	Pinion Gear (15T)	② × 1 pcs.	
OT-29	O Ring	③ × 10 pcs.	
OT-32	5.8φ Ball	④ × 10 pcs.	
OT-33	Ball Nut (M2.6)	⑤ × 10 pcs.	
OT-35	Upper Rod Set	⑥⑦ × 4 pcs. ⑧ × 8 pcs.	
OT-39	E Ring (E2.5)	⑨ × 10 pcs.	
OT-65	Wing Stay Set	⑩ × 1 pcs. ⑪⑫ × 2 pcs.	
OT-72	Heat Sink for Resistor	⑬⑭ × 1 pcs.	
OT-76	Hard Final Pinion Gear	⑮ × 1 pcs.	
OT-79	Code Set	⑯ × 1 set.	
OT-101	5.8φ Ball (Black 2.6φ Hole)	⑰ × 10 pcs.	
OT-107	Wing	⑱ × 1 pcs.	
UM-1	Gear Set	⑲ × ⑳ × 1 pcs. other 3 items	
UM-3	Gear Box	㉑㉒ × 1 pcs.	
UM-4	Motor Plate	㉓ × 1 pcs.	
UM-5	Gear Shaft Set	㉔㉕ × 1 pcs. ㉖ × 2 pcs.	
UM-7	Suspension Shaft Set	㉗㉘㉙㉚ × 2 pcs.	
UM-8	Front Shaft Set	㉛㉜ × 2 pcs.	
UM-9	Rod Set	㉝ × 2 pcs. ㉞㉟㊱ × 1 pcs. other 2 items	
UM-11	Up-right Set	㊲㊳ × 1 pcs. ㊴㊵ × 2 pcs.	
UM-12	Bulk Head Set	㊶㊷㊸㊹ × 1 pcs.	
UM-13	Suspension Arm Set	㊺㊻ × 2 pcs.	
UM-14	Servo Saver Set	㊼㊽㊾㊿㉑㉒㉓ × 1 pcs. ㉔ × 2 pcs. ㉕ × 4 pcs. other 16 items	
UM-21	Front Bumper	㉖ × 1 pcs.	
UM-26	Special Shock Stay	㉗㉘ × 1 pcs.	
UM-27	Special Chassis	㉙ × 1 pcs. ㉚㉛ × 2 pcs.	
UM-29	Stabilizer Set	㉜㉝㉞㉟㊱ × 2 pcs. ㊲㊳ × 1 pcs. ㊴ × 4 pcs.	
UM-30	Special Radio Plate	㊵ × 1 pcs.	
UM-32	Rear Wheel	㊶ × 2 pcs.	
UM-33	Front Wheel	㊷ × 2 pcs.	
UM-34	Body	㊸ × 1 pcs.	
UM-35	Decal	㊹ × 1 pcs.	
UM-36	Screw Set	Screw, Nut Wrench 1 set	
W-0109	Ball Differential	㊺ × 1 pcs. ㊻ × 1 pcs.	
W-5003	Platinum Oil Shocks (S)	㊼㊽㊾ × 2 pcs.	
W-5004	Platinum Oil Shocks (L)	㊿㉑㉒ × 2 pcs.	
W-5032	Low Profile Tire (Soft)	㉓ × 2 pcs.	
W-5061	Universal Swing Shaft	㉔ × 2 pcs.	
SC-26	Front Tire	㉕ × 2 pcs.	
SC-46	Double Sides Tape	㉖ × 1 pcs.	
SC-89	Tid Rod	㉗ × 2 pcs. ㉘㉙ × 4 pcs.	
EP-22	Hook Pin	㉚ × 5 pcs.	
EP-37	Strap (S)	㉛ × 6 pcs.	
EP-39	Ni-Cd Strap	㉜ × 6 pcs.	
SD-79	Antenna Pipe	㉝ × 5 pcs.	
CB-72	E Ring (E3)	㉞ × 4 pcs.	
KC-20	E Ring (E4)	㉟ × 4 pcs.	
1817	H.D.Rotary Speed Controller	㊱ × 1 set.	
1889	Body Pin	㊲ × 5 pcs.	
1901	Ball Bearing (5φ × 10)	㊳ × 2 pcs.	
1903	Ball Bearing (4φ × 8)	㊴ × 2 pcs.	

*RE OPTION PARTS. PLEASE SEE INSTRUCTION BOOKLET

KYOSHO CORPORATION
PRINTED IN JAPAN