

USA-1 MONSTER TRUCK

CAR CRUSHER

RADIO CONTROLLED ELECTRIC POWERED
OFF-ROAD RECREATIONAL VEHICLE

- TRUE SCALE MODEL OF EVERETT W. JASMER'S "USA-1", THE MOST POWERFUL MONSTER TRUCK ON THE TRACK.
 - DESIGNED FOR SCALE PERFORMANCE WITH TWIN-POWER MOTORS.
 - FOUR-WHEEL STEERING FOR NIMBLE HANDLING DESPITE THE "MONSTER" SIZE AND POWER.
 - HUGE 165mm (6.5 inch) TIRES CARRY THE "USA-1" OVER HIGH OBSTACLES AND ROUGH TRACKS. HIGH-GRIP PATTERN FOR TOP TRACTION.
 - FOUR-WHEEL INDEPENDENT SUSPENSION WITH WISHBONE/PARALLEL ARM LINKAGE AND DUAL SHOCKS TO KEEP VEHICLE UNDER CONTROL ON ALL SURFACES.
 - MANY REALISTIC CHROME-FINISH PARTS AND DECORATIVE LOGO STICKERS FOR SCALE APPEARANCE.
- RADIO 2 CHANNELS (NOT INCLUDED)
BATTERY 7.2V-1200/1700mAh (NOT INCLUDED)

1:10 SCALE



KYOSHO®
THE FINEST RADIO CONTROL MODELS

KIT No. 3165

BEFORE ASSEMBLY

○ Read the instruction carefully.

You can assemble the kit more easily if you have grasped the general idea of steps and structure beforehand by reading it through to the end.



○ Check the parts in the kit.

Check to see if all the parts are correctly bagged as they are listed in the Bagged Parts List. Your thorough understanding of the assembly prior to starting

will enable you to build the kit without any difficulty.



○ Check the components in the kit prior to your startings of the assembly.

Any claims for replacements or refunds for the model in the process of assembly will not accepted without shortage or inferiority of the parts.

○ Learn on the marks described in the instruction.

... Place where grease should be applied.



(It will reduce friction to assure smooth movements.)

Steps where your particular attention is required.

○ Be well aware of the different types of screws.

The difference between the TP Screw (short form of self-tapping screw) and the ordinary screw is

• TP Screw Some of them pointed tips.
Coarser Thread

• Ordinary Screw
Finer Thread

• Set Screw A hexagonal hollow in place of screw head.



○ Pick up the correct parts and screw.

Compare the shape and size of small parts, such as screws, nuts, and washers with the actual size drawing in each step.

○ Be sure about the location and direction of parts to install.

Double-check the location and direction of parts with the illustration before installation. When necessary, assemble the parts themselves tentatively before proceeding to the next step.



○ Do not tighten the TP Screw too strong...

Do not use excessive force when tightening the TP Screws, or you may strip the thread in the plastic. It is recommended to stop tightening it when the thread part on the screw goes into the plastic part and you feel some resistance from the tightening.

Over tighten may strip the thread in the plastic.

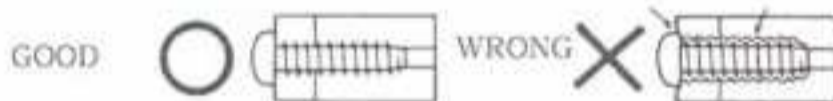

THINGS NEED BESIDES THE KIT

(2 Channel Radio System)



This model is designed for BEC system radio only. Use a radio which has a mark shown at left.

Two types of radio control set are on the market, the stick type and the steering wheel type. Choose which ever you like.

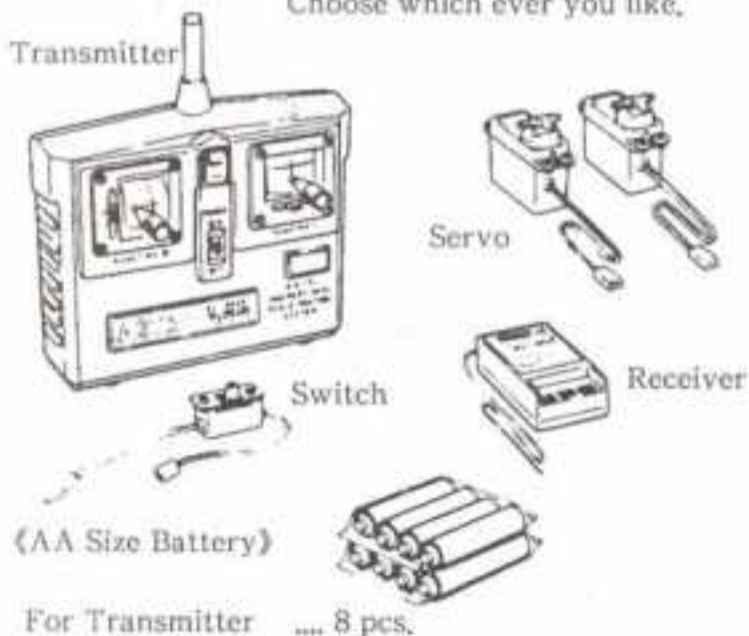

(Ni-Cad Battery)

This model is designed to use a rechargeable 7.2V Sprint Battery SCR and 7.2V Power Battery.

No.2310

7.2V Sprint Battery SCR



No.2306

7.2V Power Battery



(Charger for Ni-Cad Battery)

The Kyosho's Ni-Cad Battery is high performance, if it is charged correctly, it will operate for a considerable period.

Use one of the chargers listed below which suits your need.

NO.	Name	Time	Rate	Features
2326	7.2V Power Charger	15 min.	70%	For beginners Built-in timer
1849	Multi Charger II	20 min.	100%	Timer, Ammeter built-in
2246	FET Auto Charger	20 min.	100%	Trickle charging, Automatic cut-off at peak of charge

(Tools Required) A Hex key, Grease and Cross Wrench are in the kit.

Philips Screw Driver (L,M,S)



Needle Nose Pliers



Screw Driver (M)

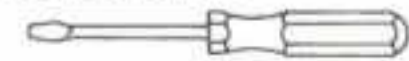

Round Cutter



Sharp Hobby Knife



Sander



Awl



Polyca Color Paint



Micron Line Tape



Wire Cutter



Instant Glue



Brush



BAGGED PARTS LIST

Bag No.	Key #	Parts Name	Q'ty	Step
Blister	1	Rotary Speed Controller	1	9
	2	Wheel Shaft	4	3
	3	Mega Monster Truck	1	21
	4	Mega Monster Truck (R)	1	22
	5	Pinion Gear (11T)	2	22
	6	Resistor	1	25
DDA-1	66	Shock Tower	4	15
	9	Gear Box (A)	2	1
USA-2	10	Gear Box (B)	2	2
	11	Knuckle Arm (A)	2	3
	12	Knuckle Arm (B)	2	3
	13	Rear Hub Carrier (Upper)	2	4
	14	Rear Hub Carrier (Lower)	2	4
	15	Front Hub R (Upper)	1	5
	16	Front Hub L (Upper)	1	5
	17	Front Hub R (Lower)	1	5
	18	Front Hub L (Lower)	1	5
	19	Knuckle Arm Washer	8	4 5
	20	Counter Gear Bushing	2	2
DDA-3	21	Half Shaft	4	4 5
	22	Main Frame	1	6
USA-4	23	Cover	1	22
	24	A Block Parts	2	11 15 17 18 22
USA-5	25	C Block Parts (Black)	4	16
DDA-5	26	E Block Parts	1	18 2
DDA-7	27	Front Guard (A)	1	17
	28	Front Guard (B)	1	17
	29	Front Guard (C)	1	17
	30	Front Guard Bar	1	17
	31	Front Body Mount	1	24
USA-8	32	Rear Body Mount	1	25
	33	Air Cleaner Cover	3	24
	34	Air Cleaner	3	24
	35	Carbretor	1	24
USA-9	36	Carbretor Base	1	24
	37	Rear Bumper	1	30
	38	Front Bumper	1	30
	39	Front Gril	1	30
	40	Front Gril Stopper	2	30
	41	Head Light Lens (R)	1	30
	42	Head Light Lens (L)	1	30
	43	Position Light Lens	2	30
	44	Door Mirror (R)	1	30
	45	Door Mirror (L)	1	30
USA-10	46	Door Mirror Stopper	2	30
	47	Diff. Joint	4	1 2
	48	Diff. Side Gear	4	1 2
	49	Idle Gear	2	1
	50	Counter Gear	2	2
	51	Diff. Carrier	2	2
	52	Diff. Bevel Gear	6	2
USA-11	53	Z Block Parts	1	11
	54	5.8 φ Ball Link	20	7 15 16
	55	Idle Gear Shaft	2	1
	56	Idle Gear Shaft Pin	2	1
	57	Diff. Joint Shaft	2	1
	58	Counter Gear Shaft	2	2
	59	Sus. Shaft (A)	4	8
	60	Sus. Shaft (B)	4	8
	61	Sus. Shaft (C)	4	8
	62	M3 Rod 43mm (Tie Rod)	4	15
	63	M3 Rod 25mm (Upper Sus.)	4	7
	64	Shock Shaft	8	16
	65	Wheel Shaft Pin	4	27
67	4 φ x8 Metal Bushing	8	1 2	

Bag No.	Key #	Parts Name	Q'ty	Step
USA-11	68	5 φ x10 Metal Bushing	8	3
	69	8 φ x12 Metal Bushing	4	1 2
	8	5.8 φ Pillow Ball	20	8 9 10 11
USA-12	70	4.5 φ Ball	1	10
	71	4.5 φ Ball Link	1	10
	72	Speed Control Rod	1	10
	73	Double Sided Tape	1	10 13
	74	Rubber Pipe	4	15 20
	75	Motor Cord	1	22
	76	Resistor Cover	1	25
	77	Resistor Base	1	25
	78	Wheel Hub	4	27
	79	Grease	2	
	80	Torque Rod	1	14
USA-13	81	Vinyl Tie Wrap	1	22
	82	Battery Hatch	1	21
	83	Window	1	23
	84	Motor Cover	2	22
USA-14	7	Shock Spring	8	10
	85	Roll Bar (F)	1	25
	86	Roll Bar (R)	1	25
	87	Roll Bar Back Stay (R)	1	25
	88	Roll Bar Back Stay (L)	1	25
USA-15	89	Fog Light Cover	5	29
	90	Fog Light	1	29
	91	Antenna Holder	1	26
DDA-16	92	Servo Mount	1	10
	93	Upper Sus. Arm	4	7
Others	94	Lower Sus. Arm	4	8
	95	A Block Parts (A-1,2)	2	6
Others	96	Tire	4	27
	97	Wheel	4	27
	98	Body	1	26
Others		Instruction Manual	1	
	99	Antenna Pipe	1	26
	100	Decal	1	14 22 31
	101	Mirror Seal	1	31
	102	Grommet	2	11 13
	103	5 φ Lock Ring	6	28
	104	Body Pin	5	21 33
	105	Hook Pin	4	33
	106	E Ring (E4)	8	13
	USA-17		TP RH Screw M2×6	18
		" M2×10	1	
		" M2.6×8	10	
		" M3×8	49	
		" M3×12	52	
		" M3×16	16	
		RH Screw M2×10	2	
		" M3×8	5	
		" M3×12	12	
		" M3×25	8	
		" M3×28	4	
		" M3×60	1	
		Set Screw M3×3	2	
		Nut M2	1	
		" M3	11	
		Flanged Nut M3	14	
		Nylon Nut M3	9	
	" M4	4		
	Washer M3	20		
	" M5	4		
	" M8	4		
	Cross Wrench	1		
	Hex Key (1.5mm)	1		

LAYOUT DRAWING OF PLASTIC PARTS

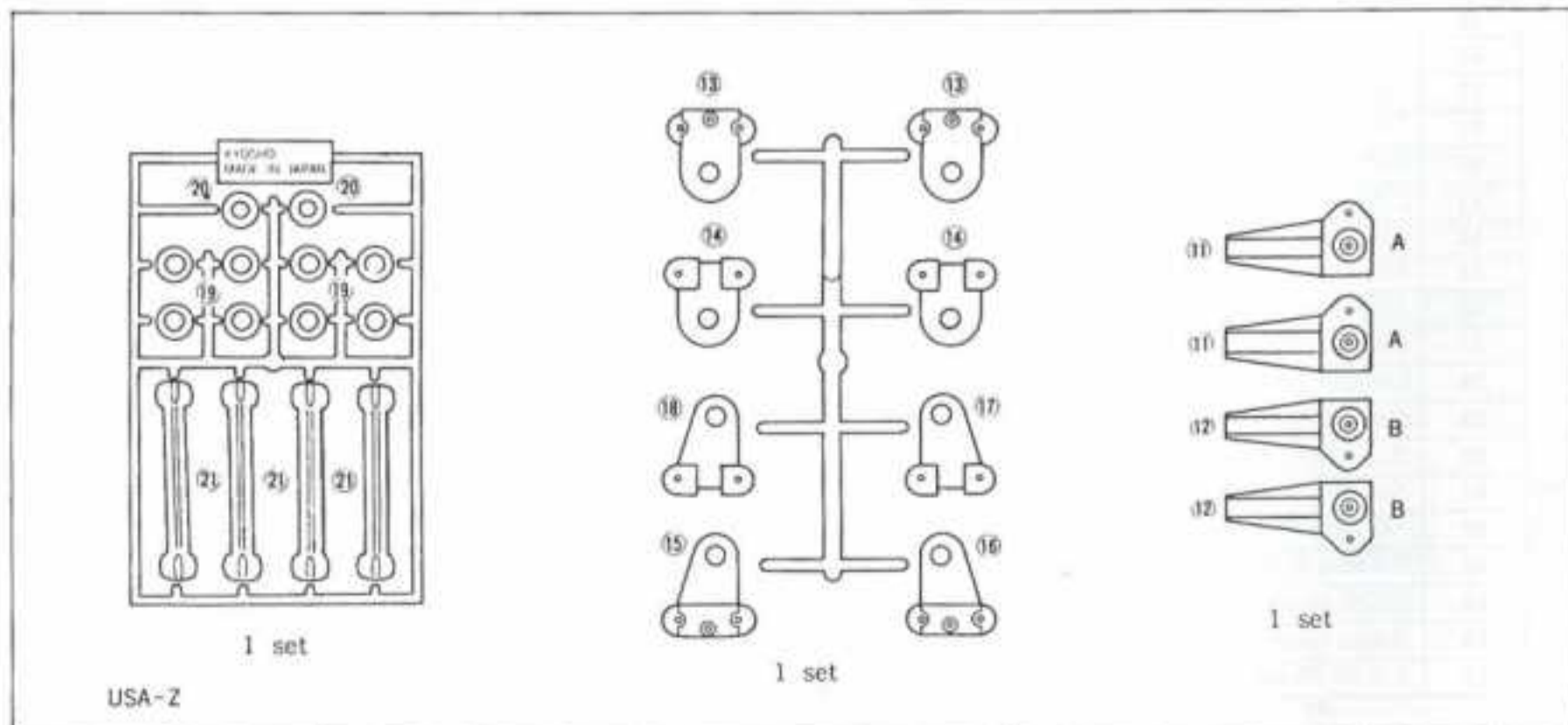
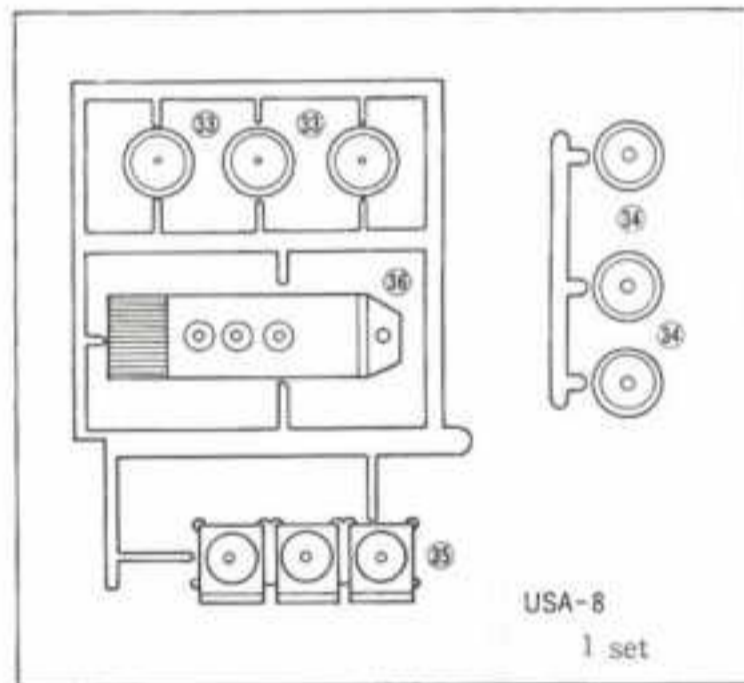
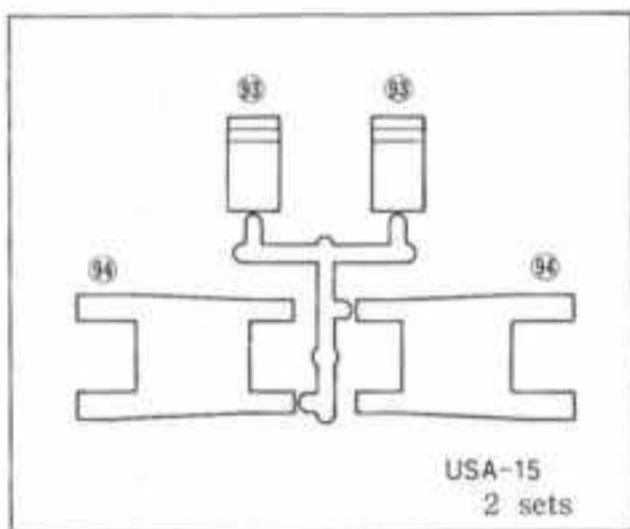
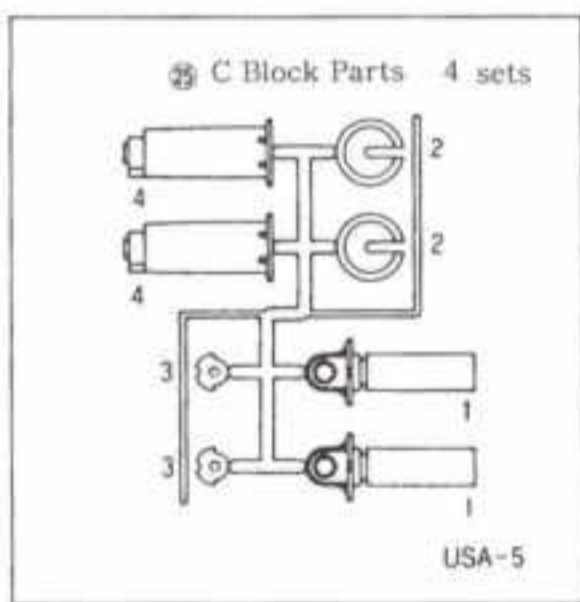
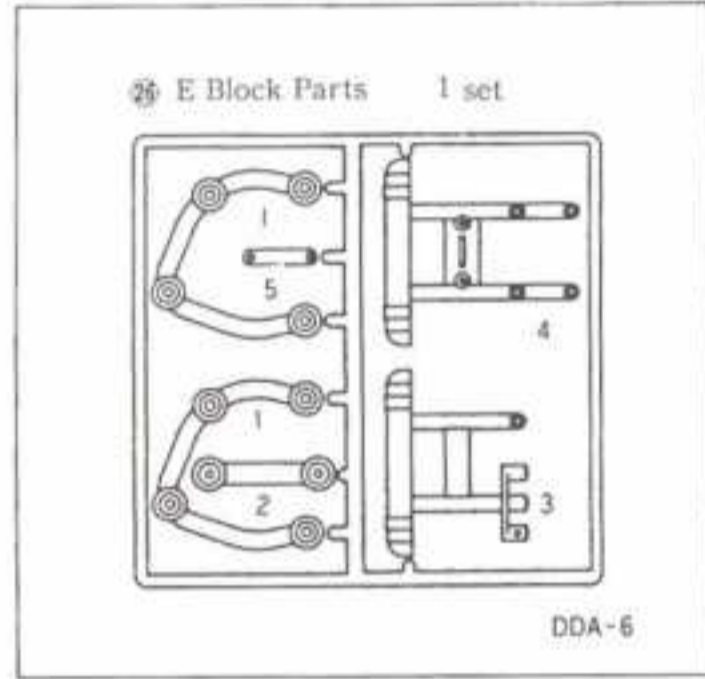
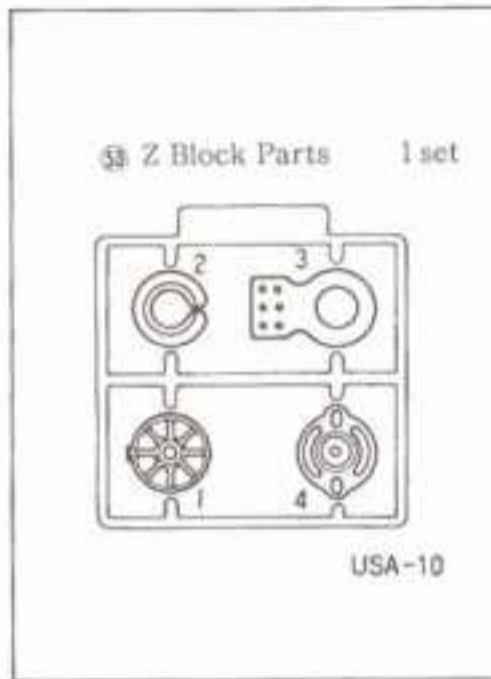
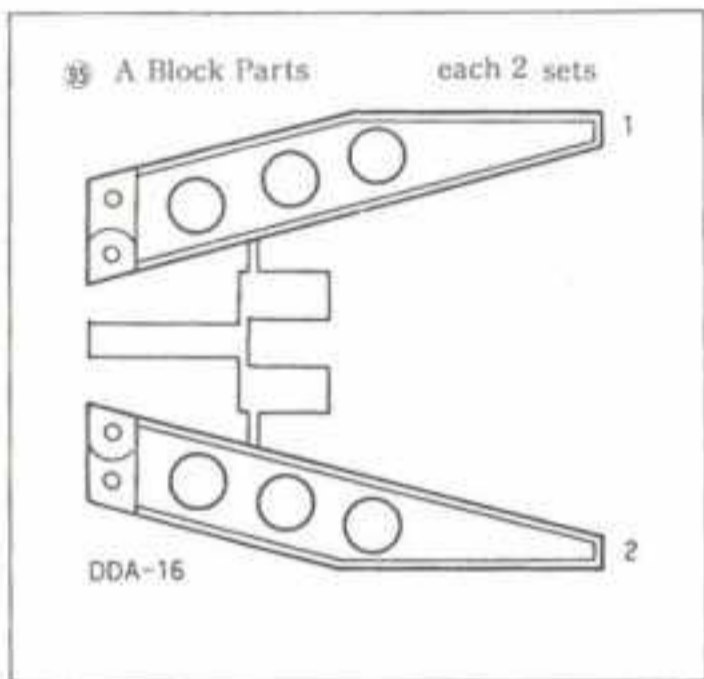
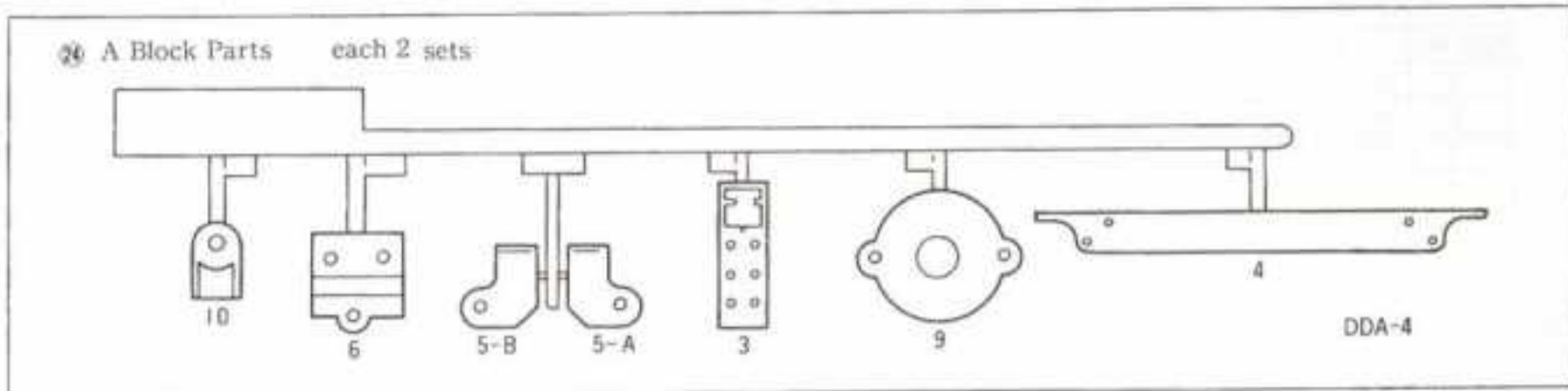

1 ASSEMBLY OF GEAR BOX (1)

M8 Washer2

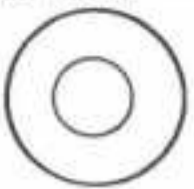

35 Idle Gear Shaft2

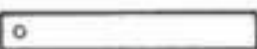

37 Diff. Joint Shaft2



38 Idle Gear Shaft Pin2



39 4 φ x8 Metal Bushing.....4



40 8 φ x12 Metal Bushing.....2



* Assemble 2 sets,

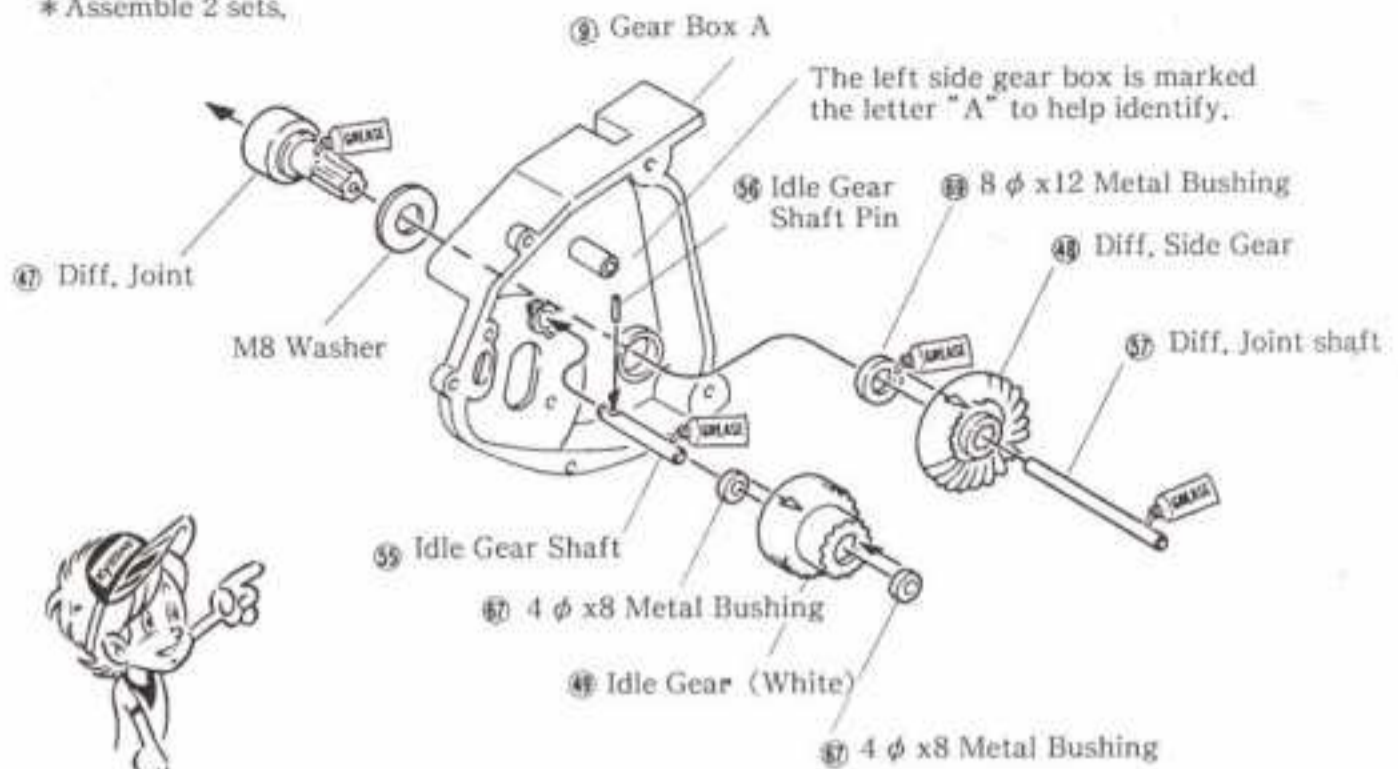

It is very important to thoroughly lubricate the gear & gear shafts during assembly. Use grease liberally.

2 ASSEMBLY OF GEAR BOX (2)

M8 Washer2

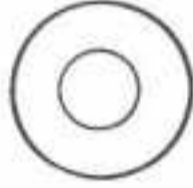

M3x12 TP Screw8

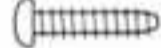

50 Counter Gear Shaft.....2



37 4 φ x8 Metal Bushing.....4



40 8 φ x12 Metal Bushing.....2



M3x12 TP Screw

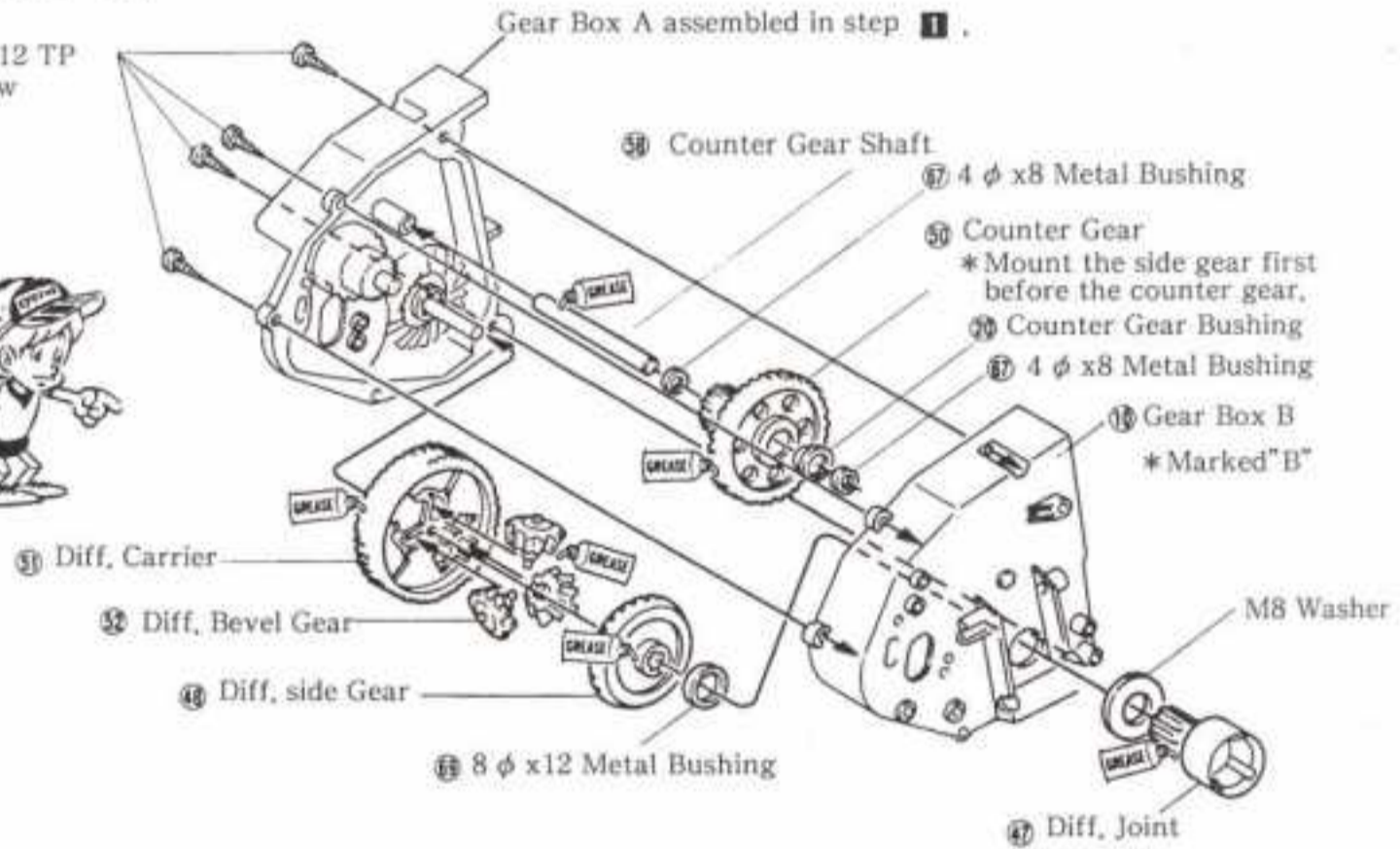

3 ASSEMBLY OF KNUCKLE ARM

M5 Washer4



8 5.8 φ Pillow Ball4



40 5 φ x10 Metal Bushing.....8



M4 Nylon Nut4



* Assemble 2 each for A & B.

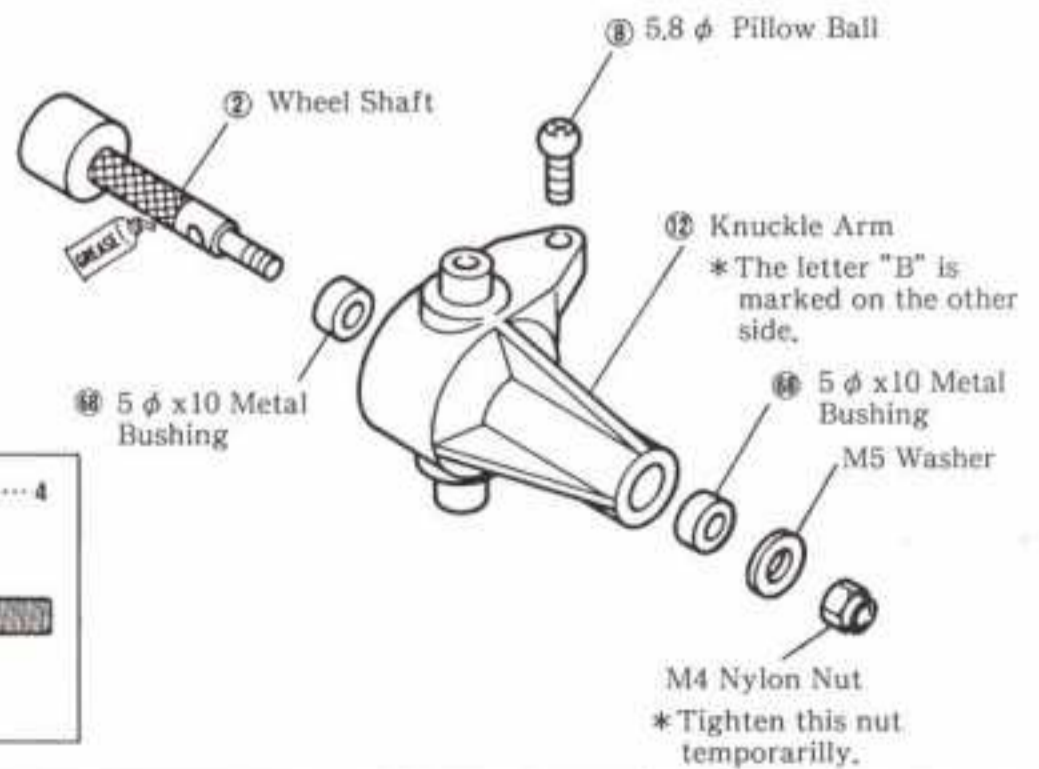
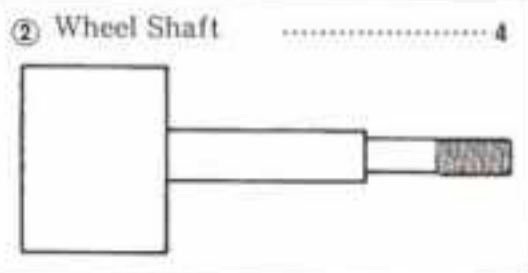

4 ASSEMBLY OF REAR HUB CARRIER

* Assemble 1 set each for A&B.

Tighten screws so the knuckle arm can move smoothly.

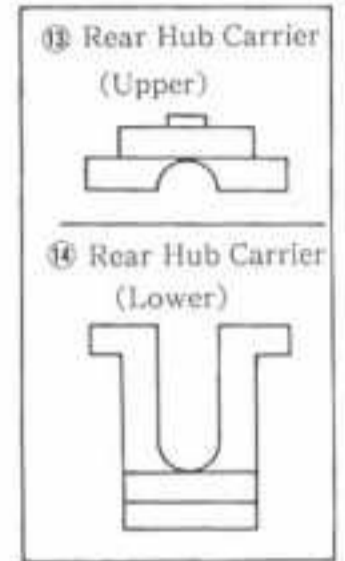
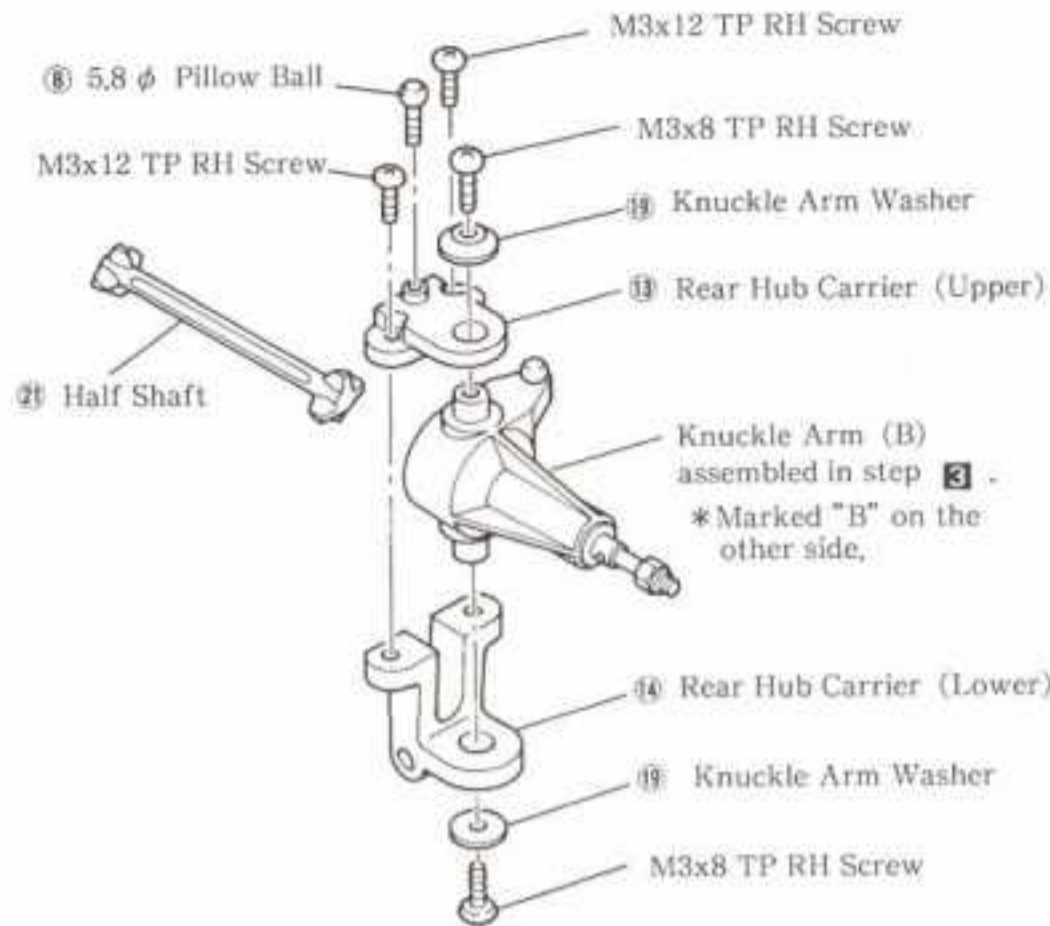

5 ASSEMBLY OF FRONT HUB CARRIER

* Assemble 1 set each for A&B.

Tighten screws so the knuckle arm can move smoothly.

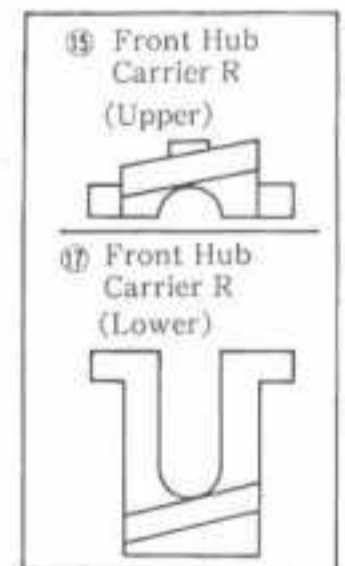
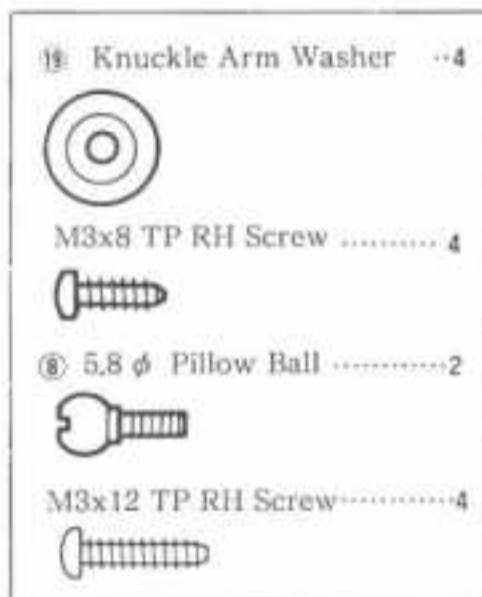
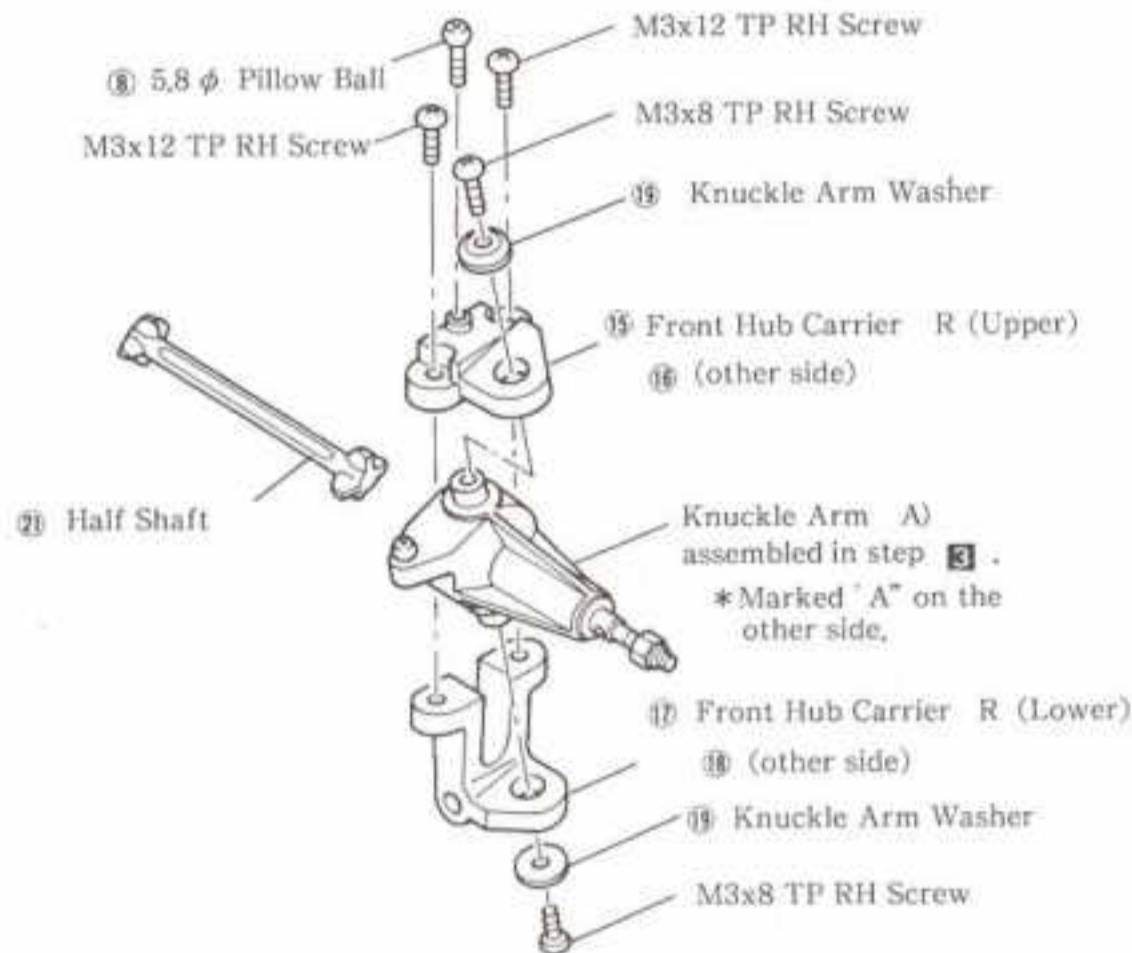

6 ASSEMBLY OF MAIN FRAME

* Install Front & Rear Gear Box.

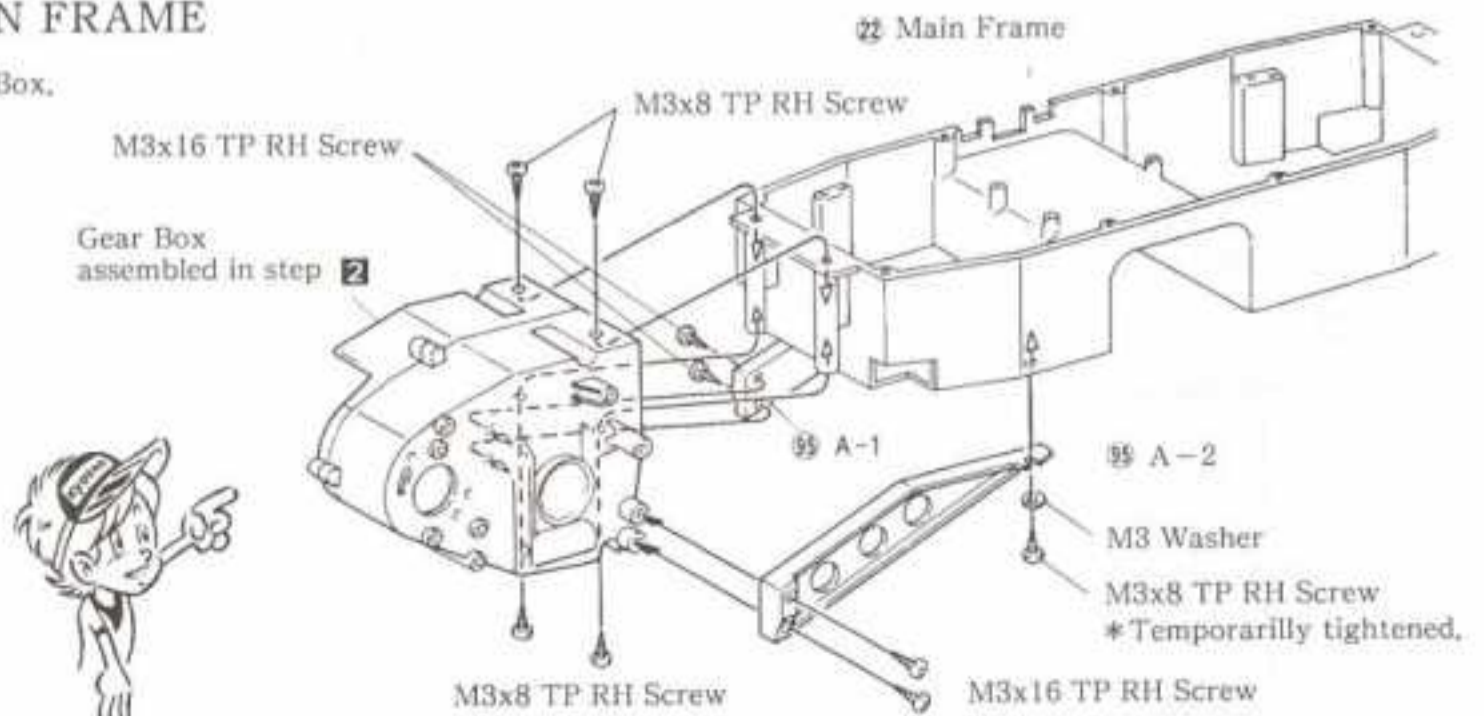
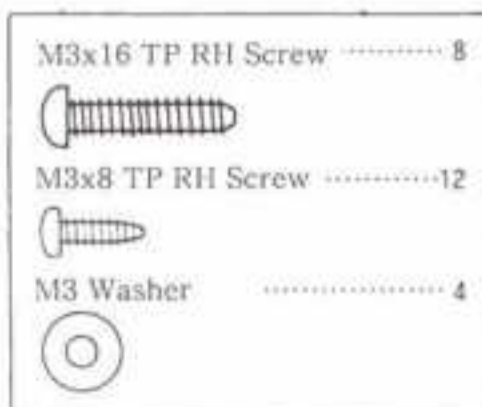

7 ASSEMBLY OF UPPER SUSPENSION ARM

* Assemble 4 sets.

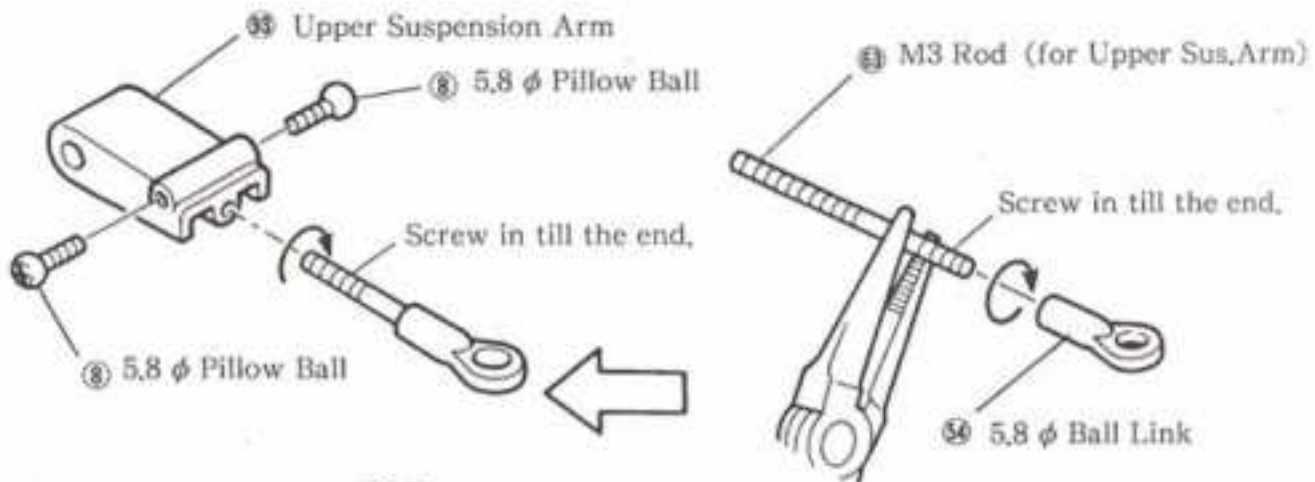

⑧ 5.8 φ Pillow Ball8
⑬ M3 Rod (for Upper Sus,Arm)4
⑭ 5.8 φ Ball Link4



Slightly flaring the tie rod ends will help start the rods to thread.



8 INSTALLATION OF SUSPENSION ARM

* Assemble both sides.

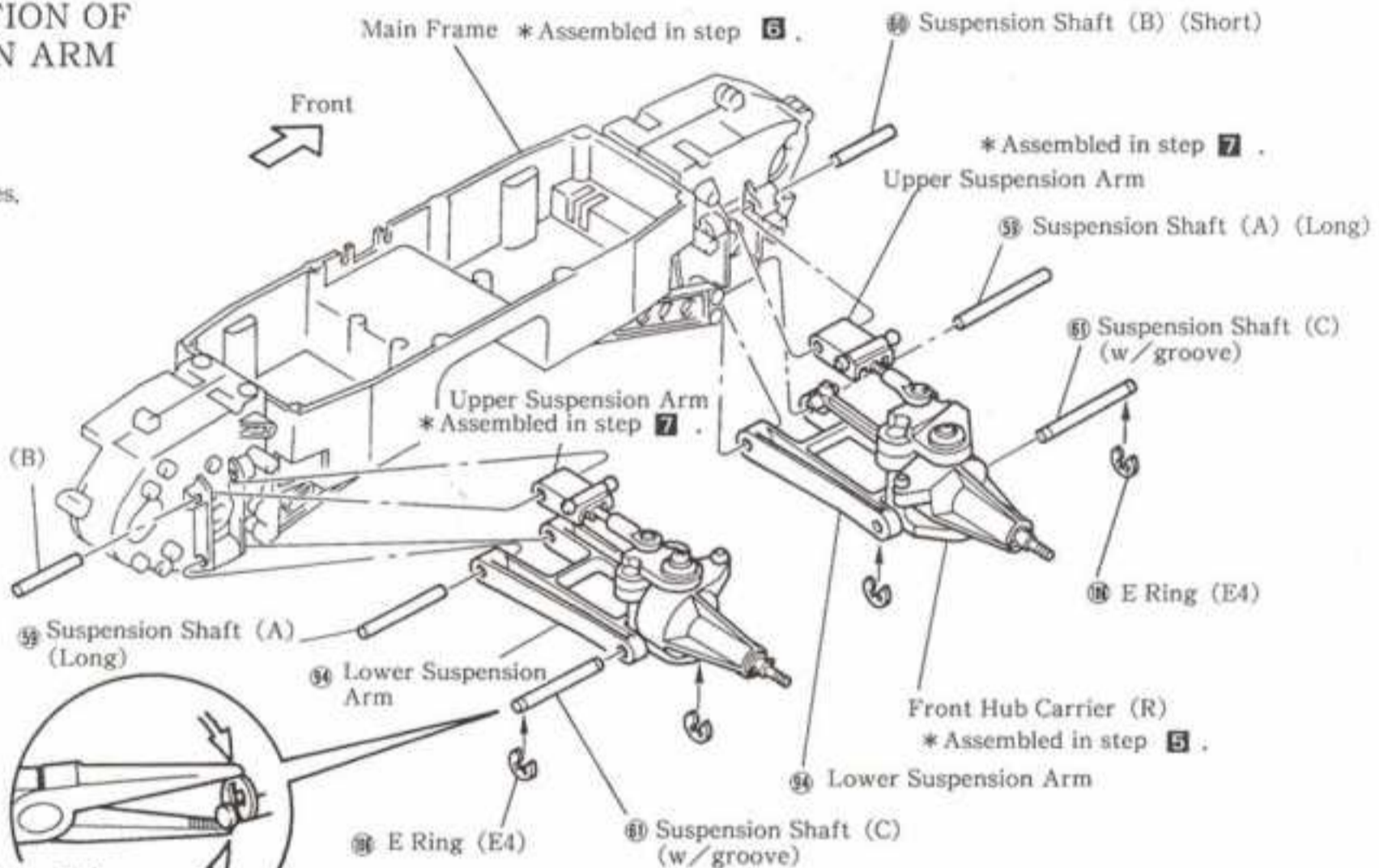

Fit an E Ring a pair of pliers.

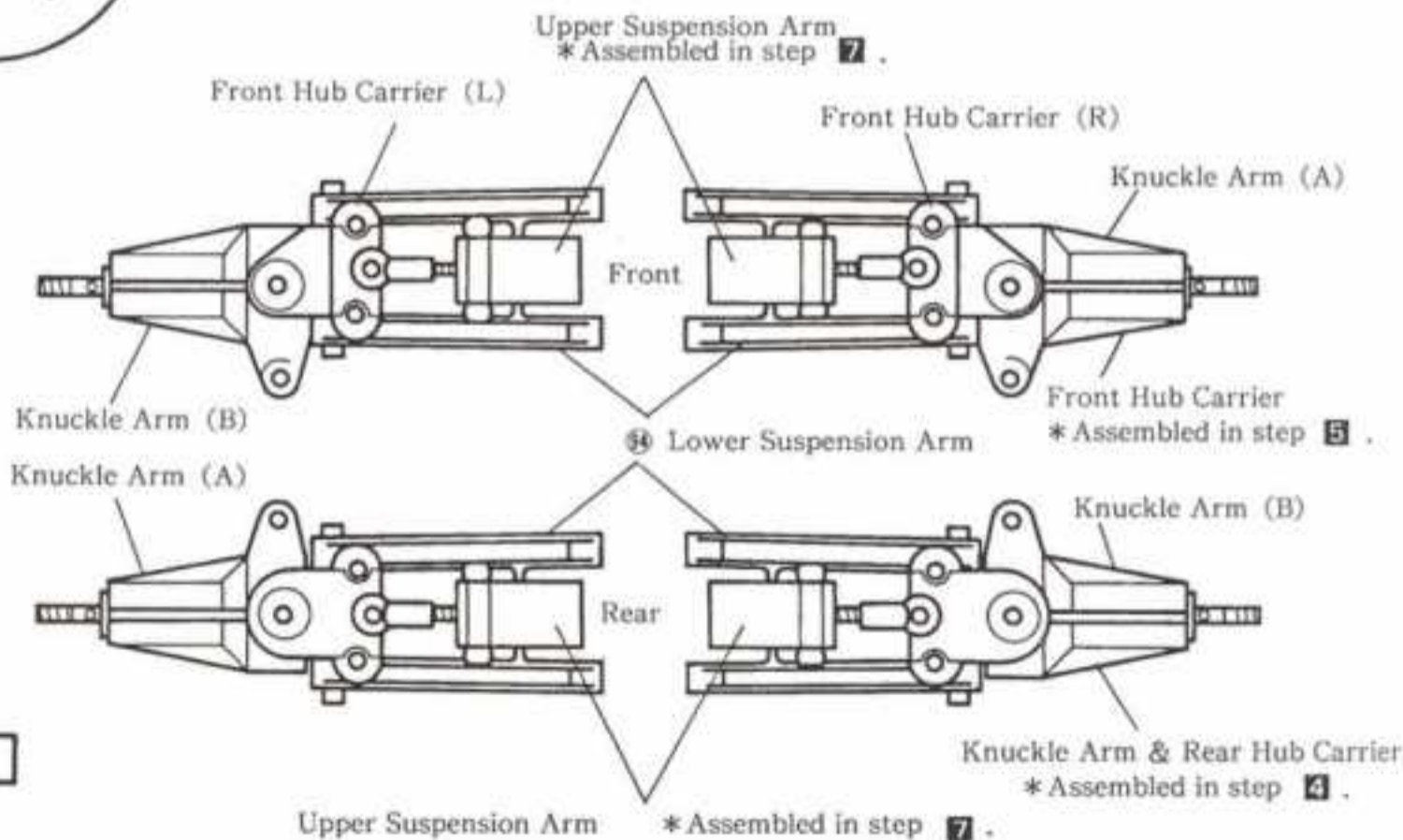

⑮ E Ring (E4)8
⑯ Suspension Shaft (C)4
⑰ Suspension Shaft (B)4
⑱ Suspension Shaft (A)4

9 HOW TO CHECK RADIO SYSTEM

Operate the radio control units in order of the numerical figures.

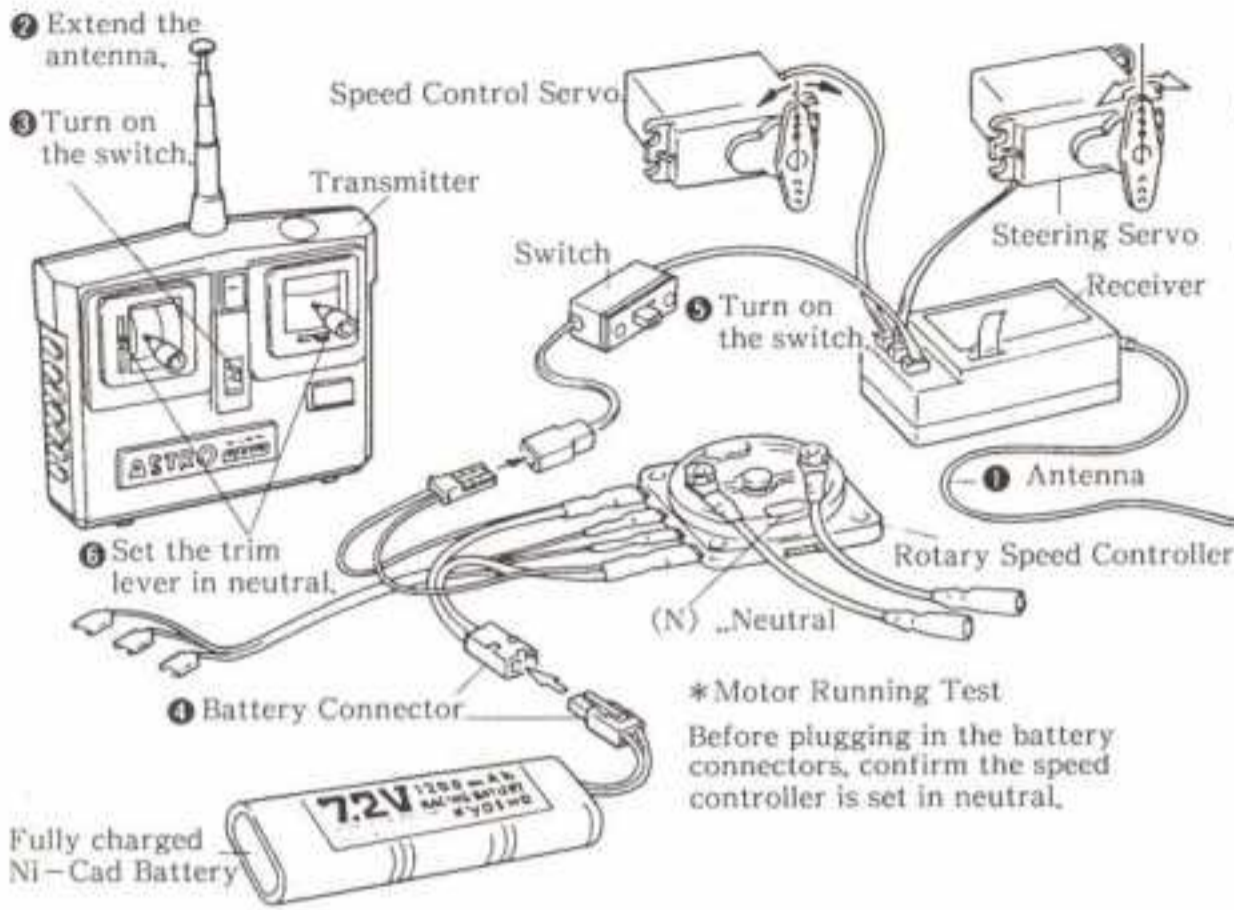

This model is for BEC system radio only.

A two channel radio is composed of things like a transmitter, receiver, servos, and battery.

- Transmitter ... It is effect a control box, Signal waves are transmitted through an antenna according to the stick movements.
- Receiver ... Receives the signals from the transmitter and send them to the servos.
- Servo ... They really move the control mechanism of a model car in accordance with the signals from the receiver.
- Antenna ... An antenna on the transmitter sends signals, and one on the receiver accepts them. They should be fully extended.
- Trim Lever ... They will adjust the neutral position of servos, thus regulate the steering and advancing controls finely.
- Battery Meter ... You can tell the amount of electricity in a battery and how the signals are emitted.
- Servo Horn ... They are intermediate devices on the servos to activate the controls. There are several types in shape, They should be selected depending upon the usage.

When switch on the radio ... Get the switches in order from transmitter to receiver.

When switch off the radio ... In order from receiver to transmitter.

10 ASSEMBLY OF SPEED CONTROL SERVO

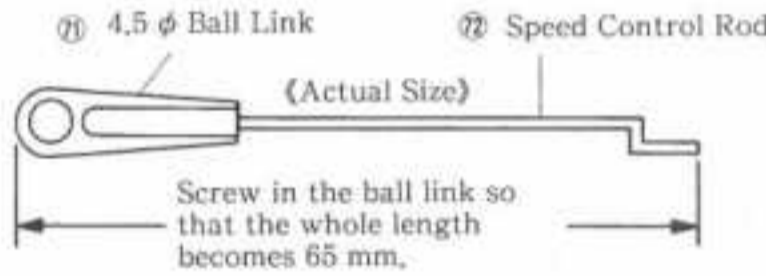
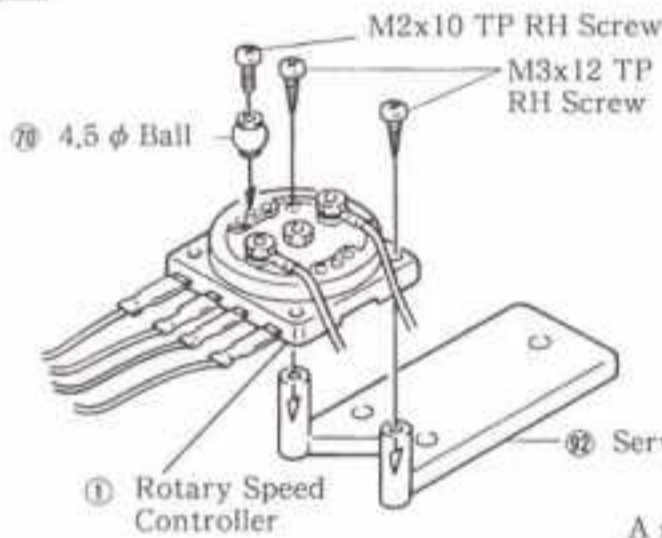

*Cut off the shaded area,

Trim the arm into the shape as shown,

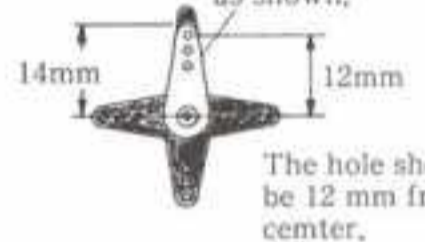

A screw which was used to fix the servo horn,

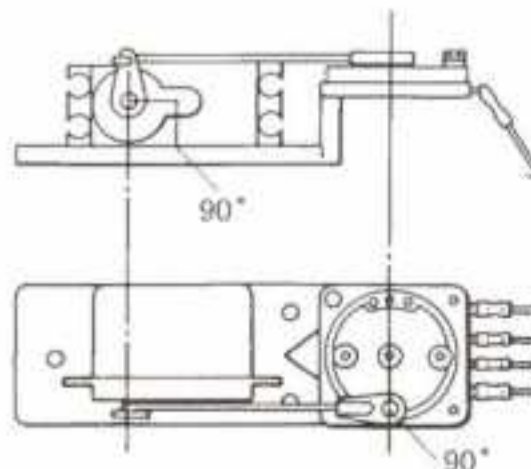
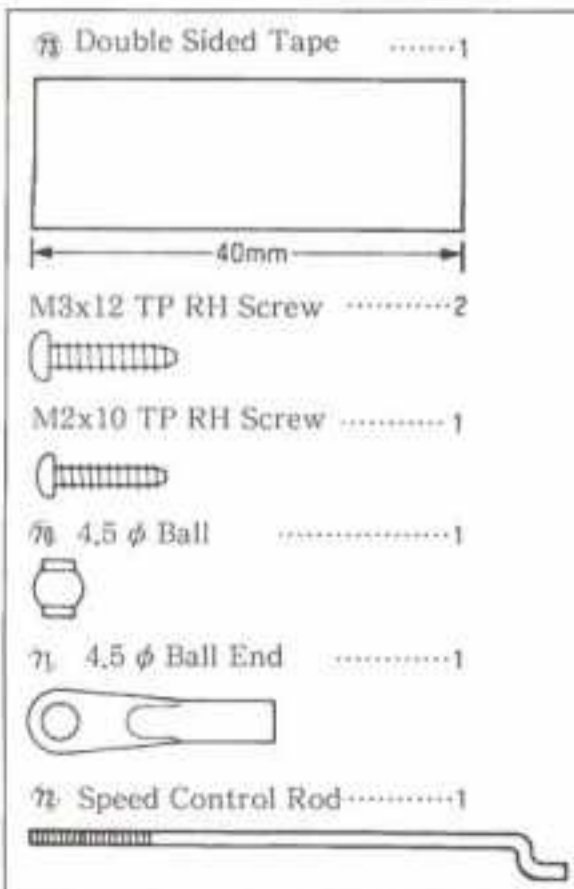
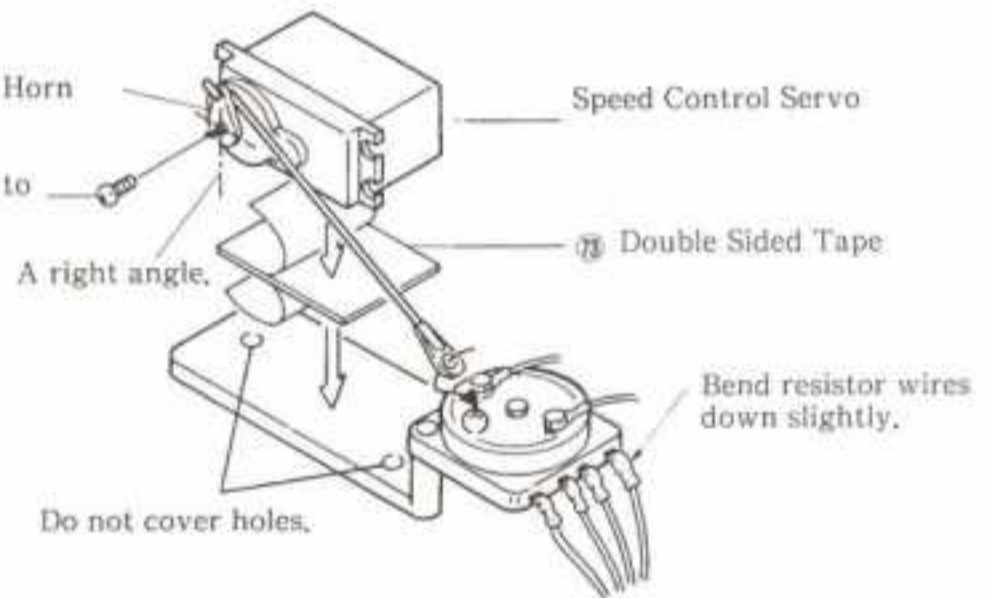

* Servo horn and control rod should be at a 90° angle.

11 ASSEMBLY OF STEERING SERVO

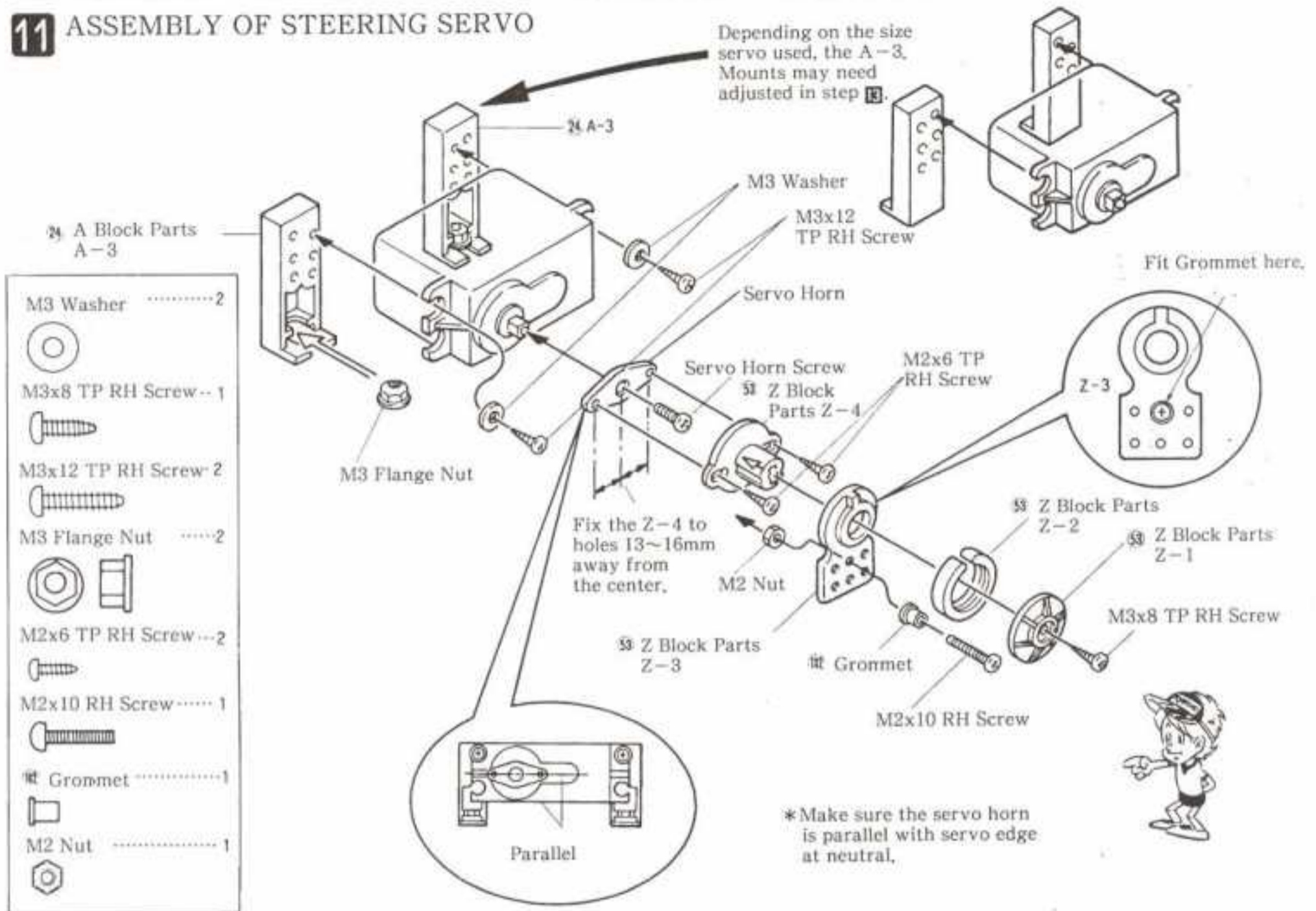

12 ASSEMBLY OF STEERING

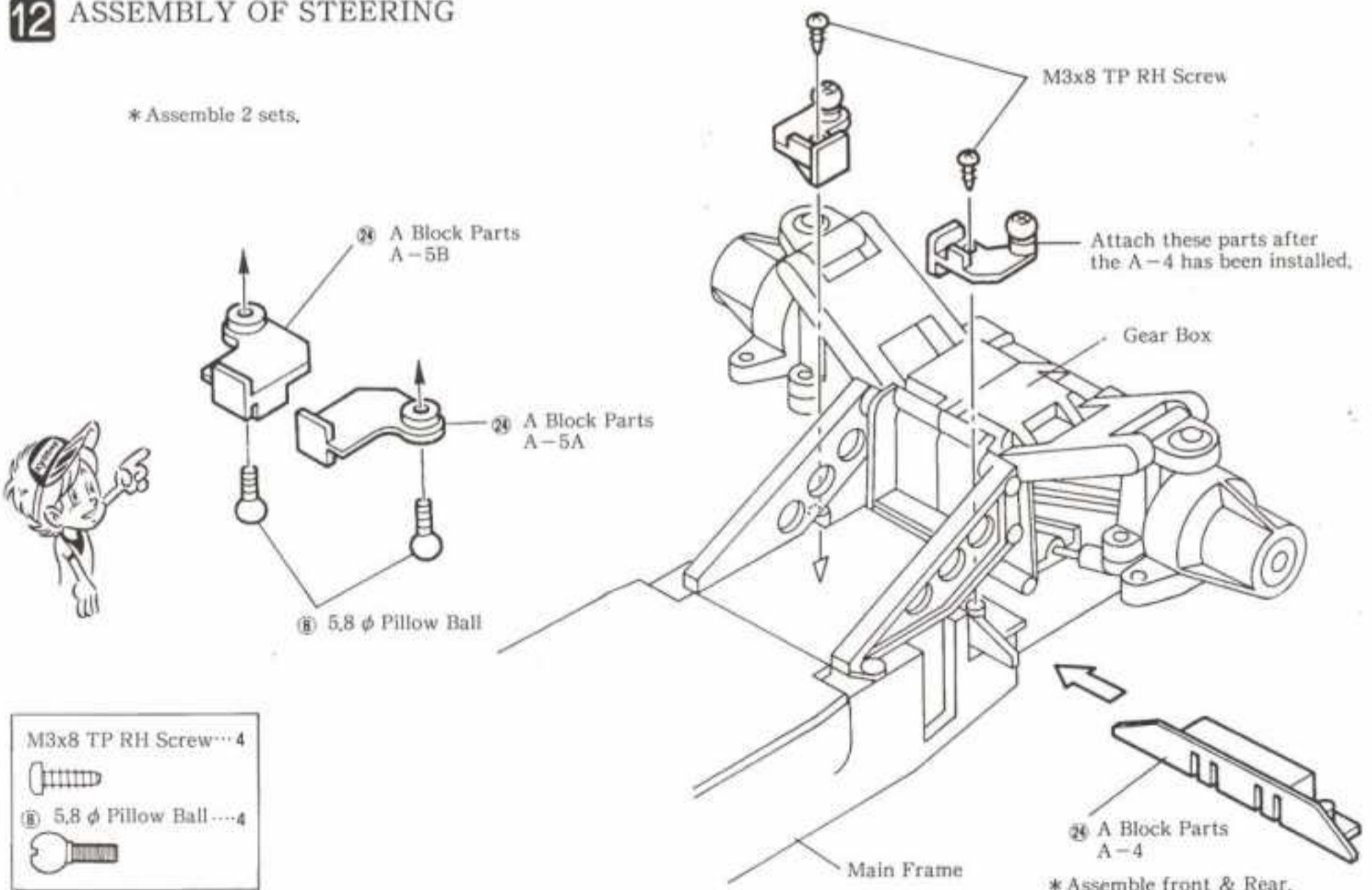

13 INSTALLATION OF R/C UNIT

- M3x8 TP RH Screw 3
 - M3x12 TP RH Screw 2
 - M3x8 RH Screw 2
 - M3 Washer 2
 - (Grommet 1)
 - Double Sided Tape 1
- 

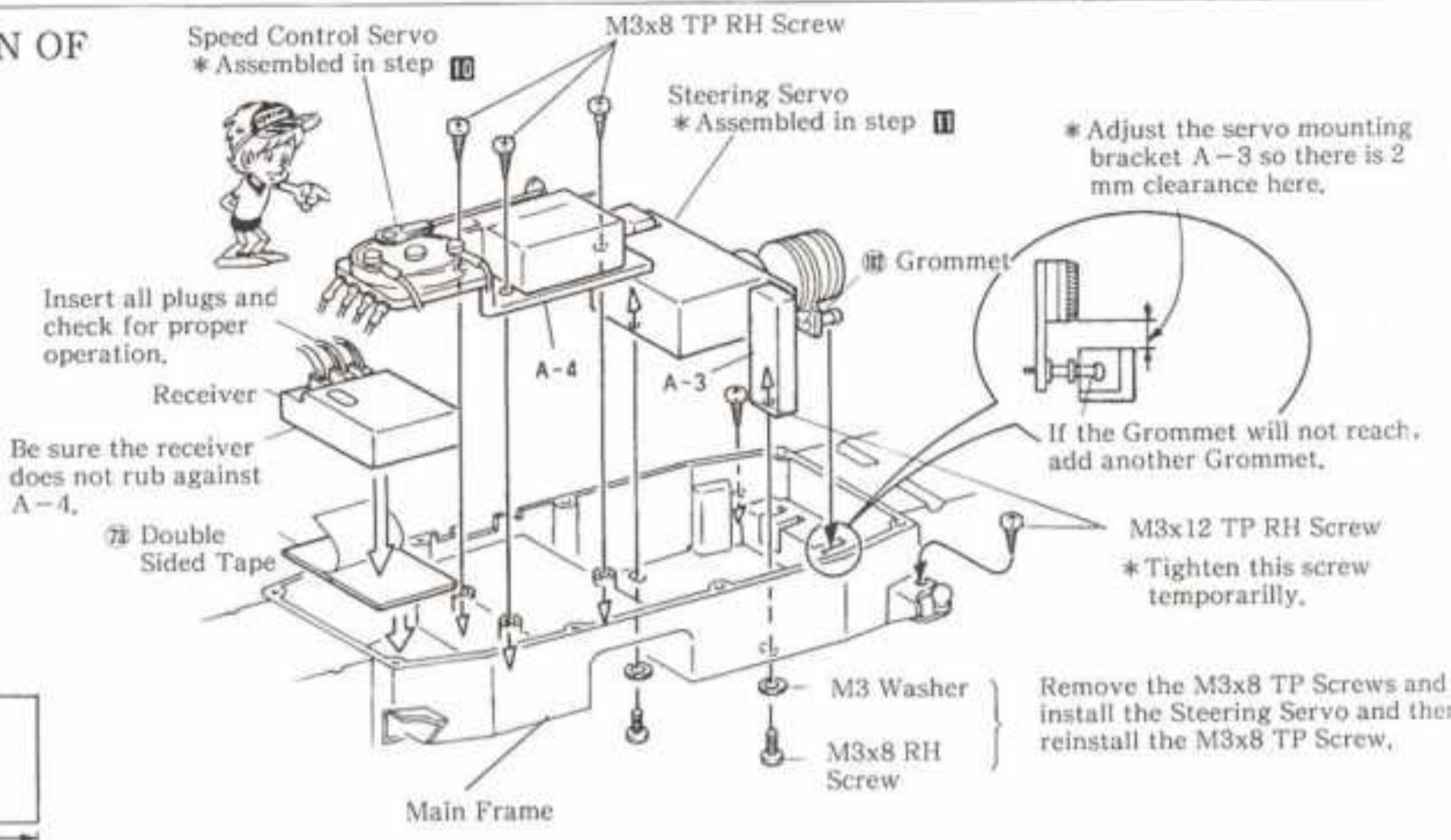

14 INSTALLATION OF TORQUE ROD

- M3x12 TP RH Screw 4
- M3x8 TP RH Screw 2
- M3 Washer 2

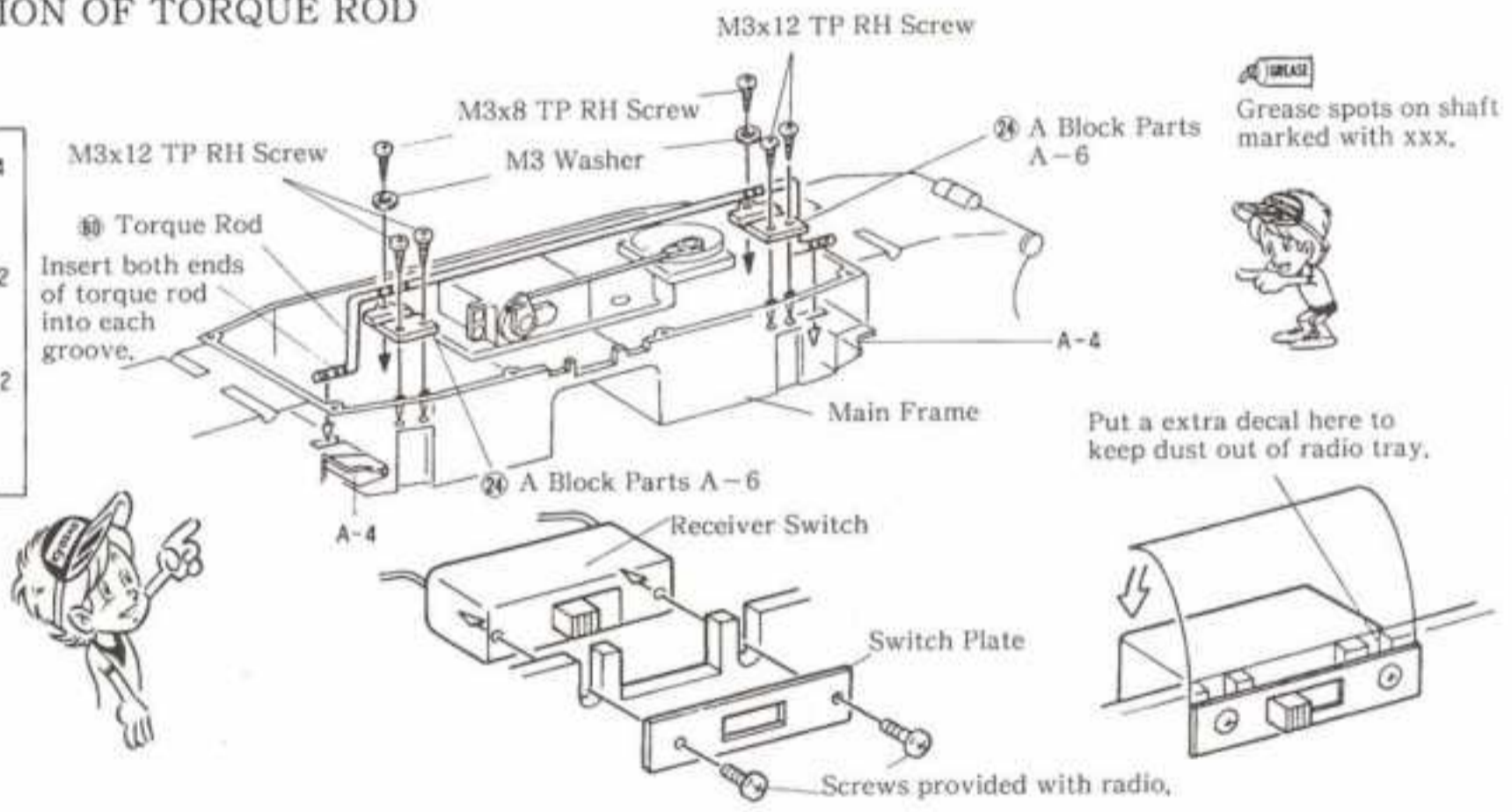

15 INSTALLATION OF TIE ROD

- 5.8 ϕ Ball Link 8
- M3 Rod (for Tie Rod) 4

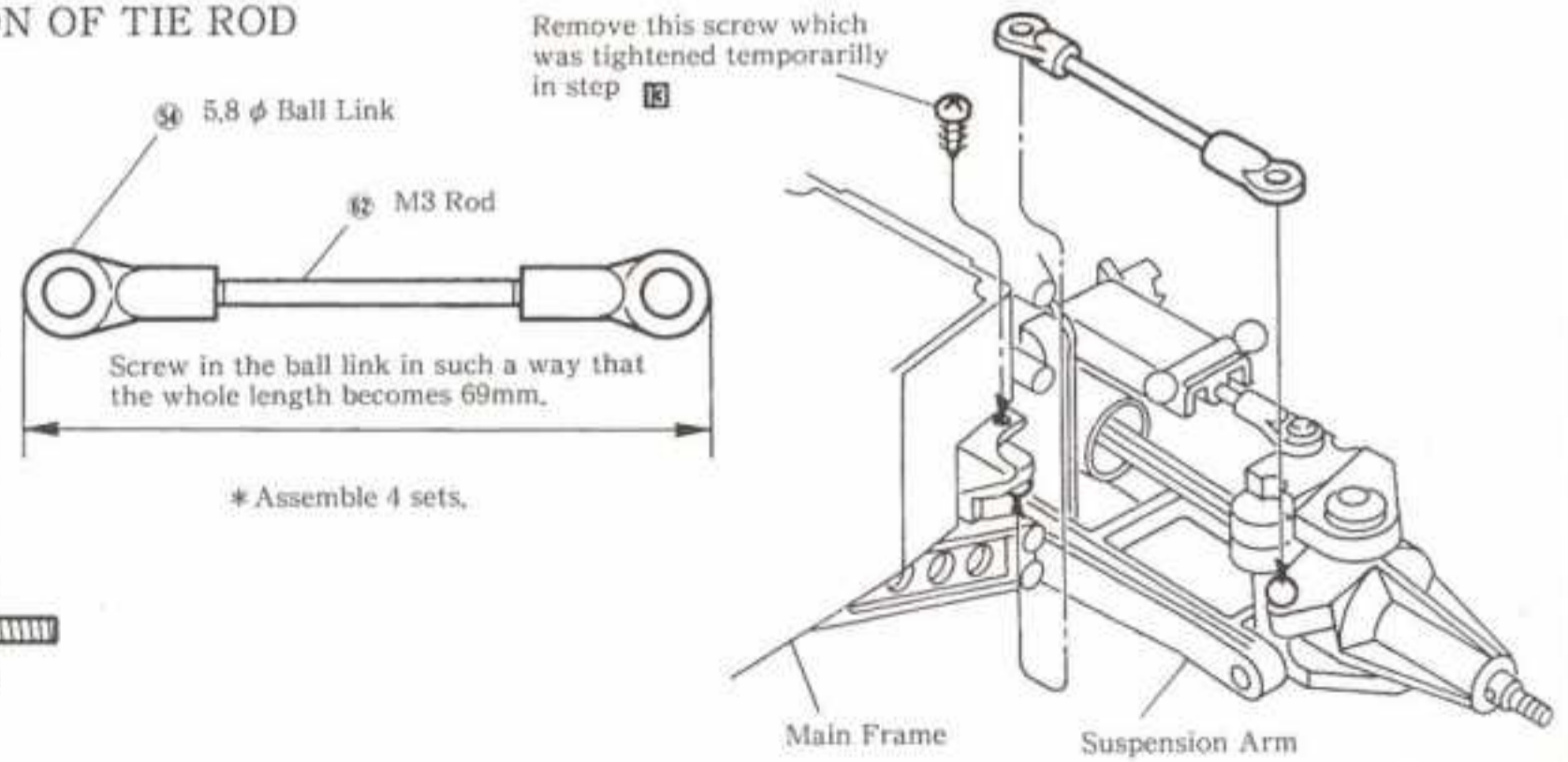

16 ASSEMBLY OF SHOCK

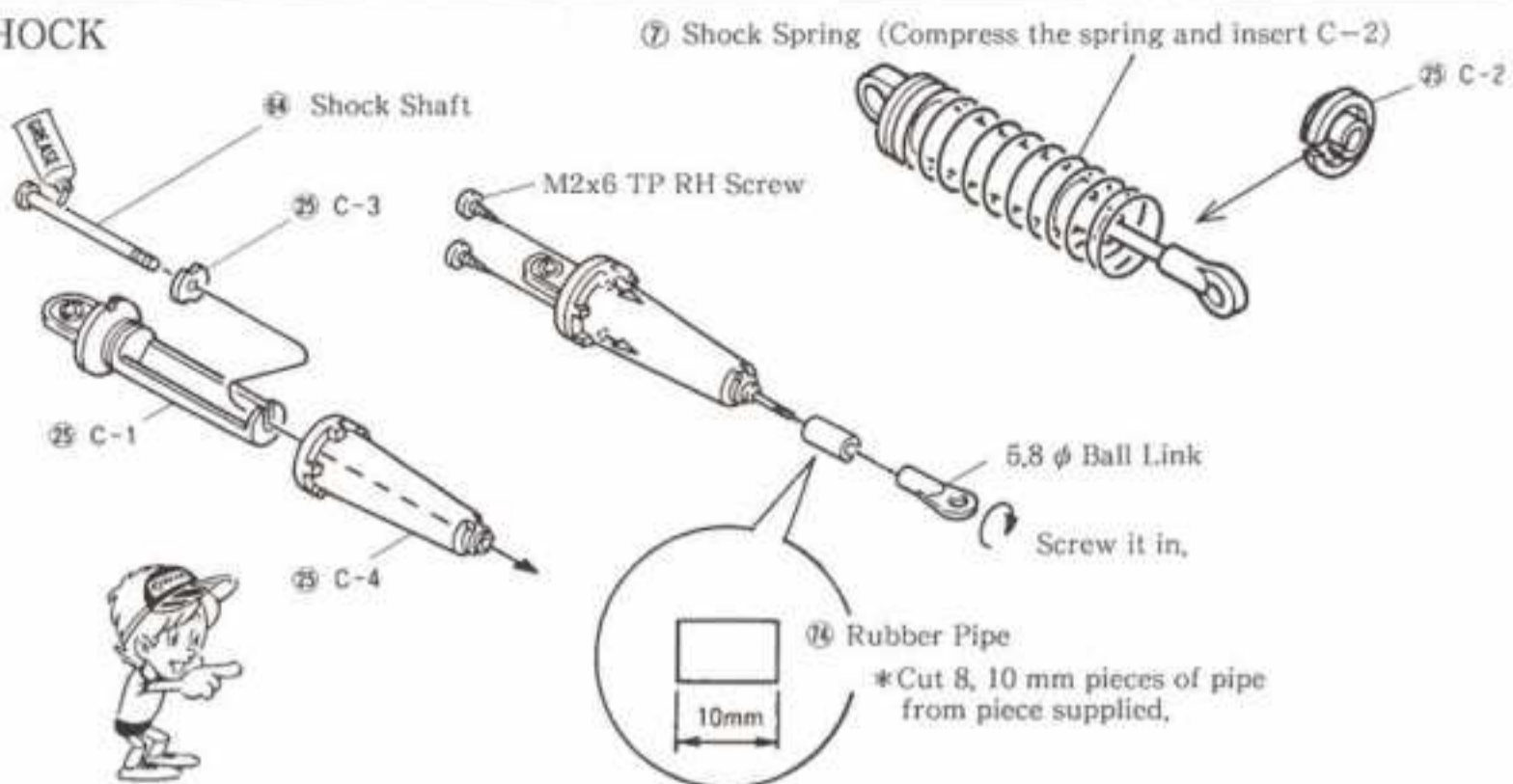

17 ASSEMBLY OF FRONT GUARD

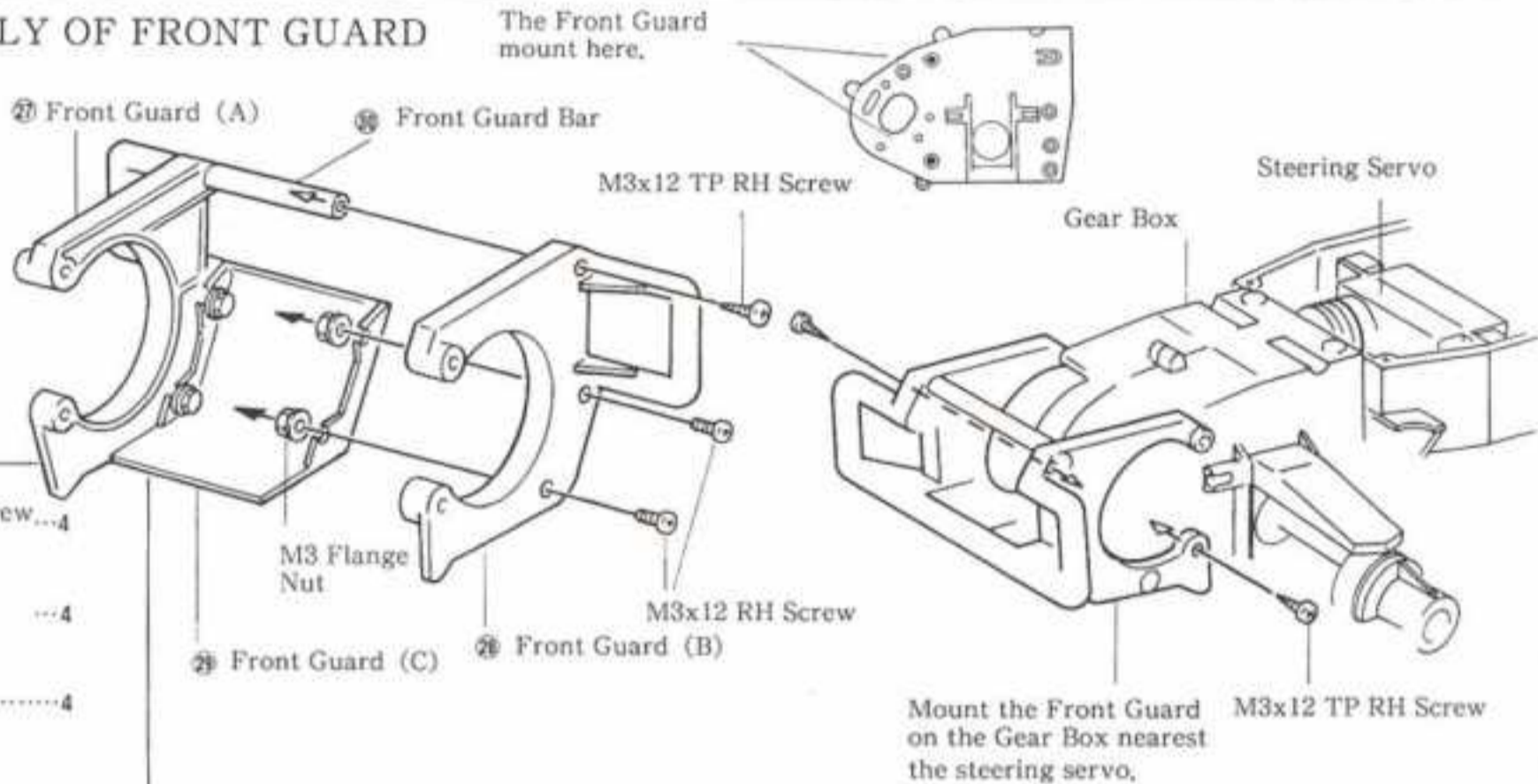
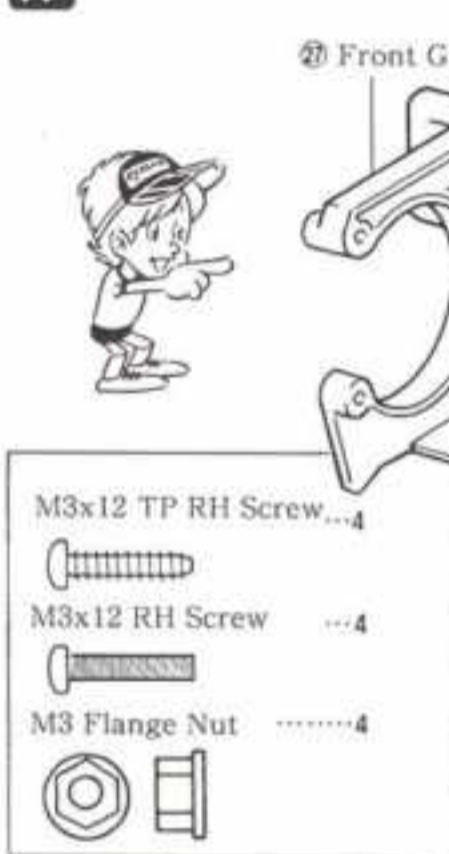

18 INSTALLATION OF REAR GUARD

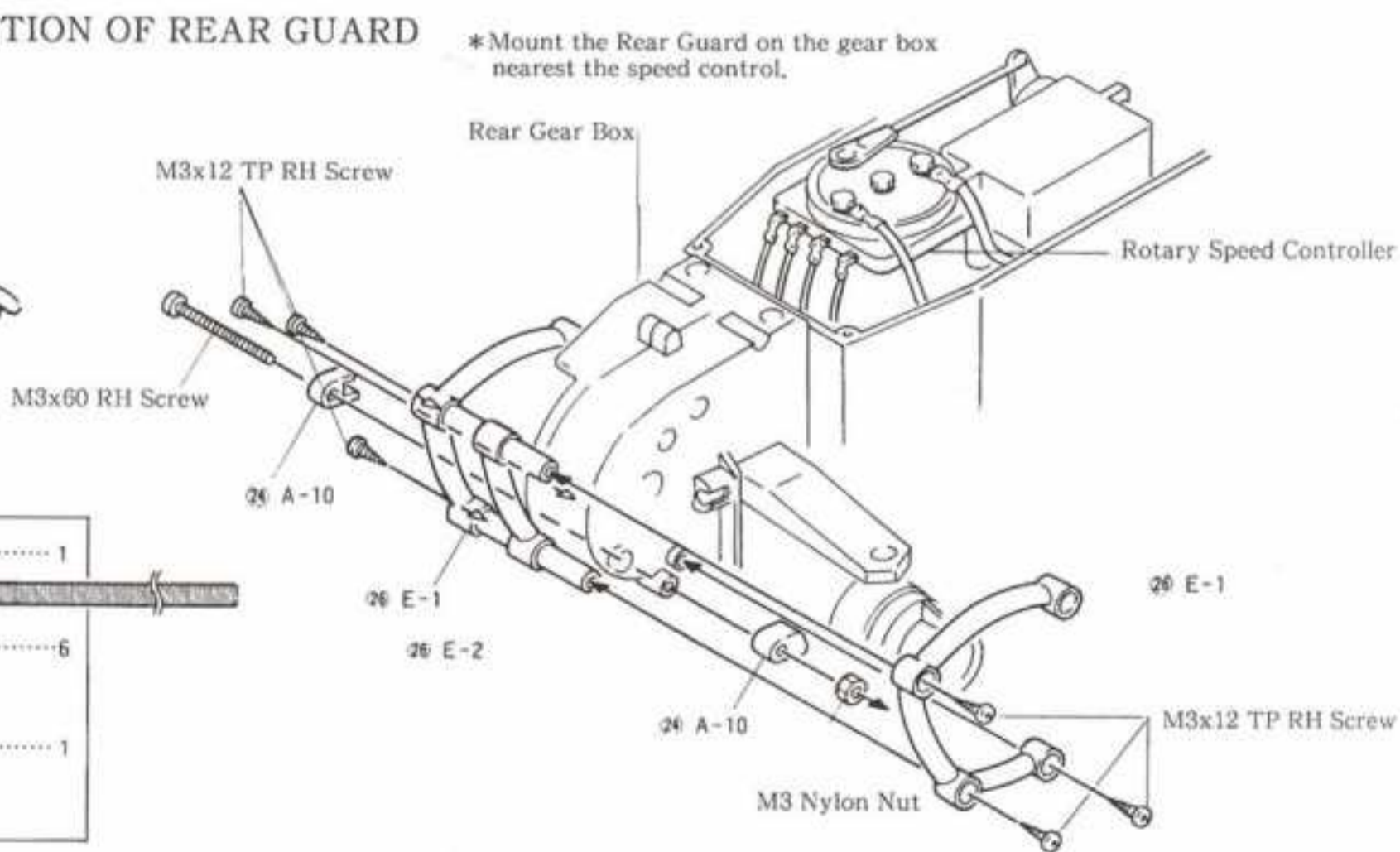

19 INSTALLATION OF SHOCK STAY

M3x25 RH Screw 8
M3x16 TP RH Screw 8
M3 Nut 8



* Assemble 2 sets,
Be careful about
the direction.

M3 Nut

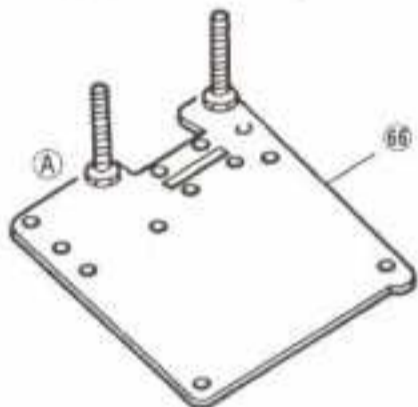
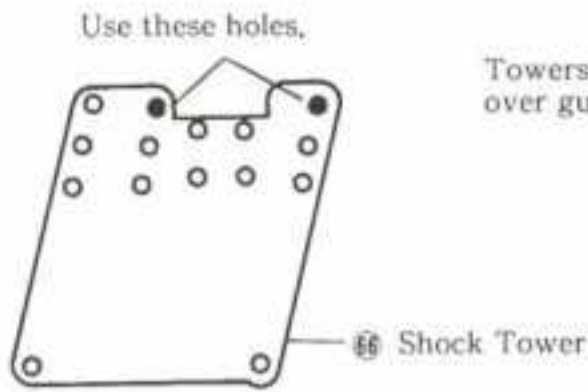
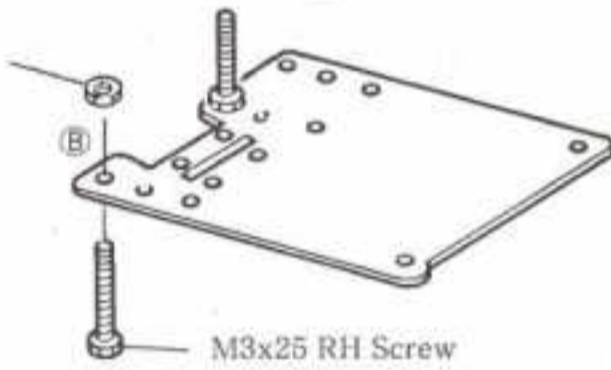

M3x16 TP RH Screw

Towers mount
over guards.

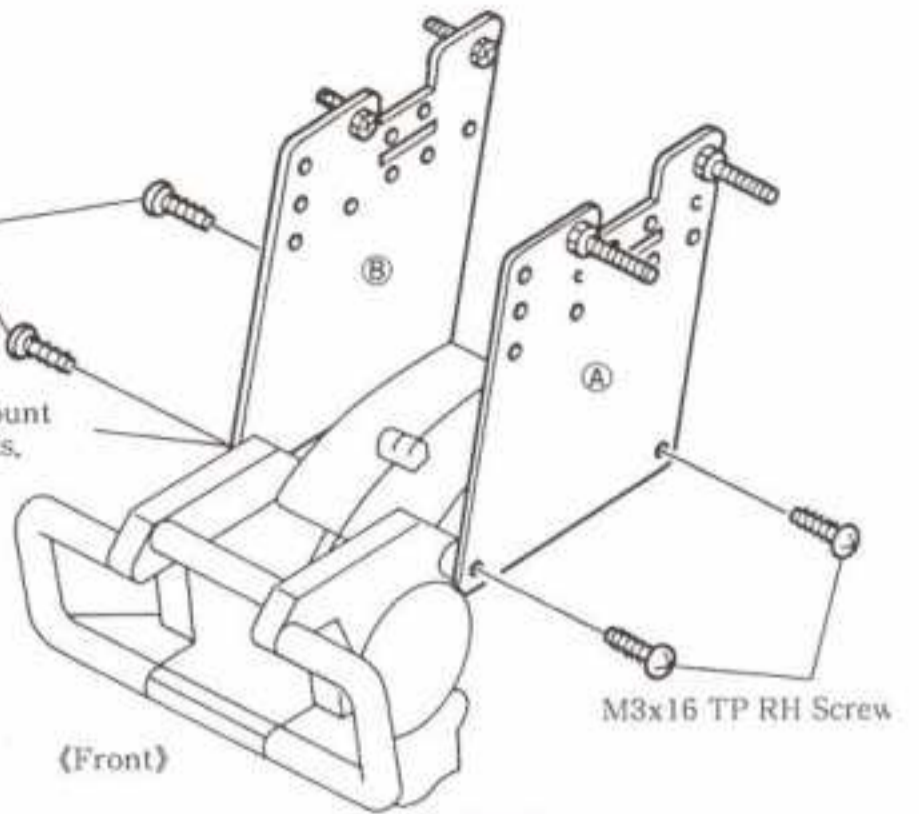

M3x16 TP RH Screw

Towers mount
over guards.

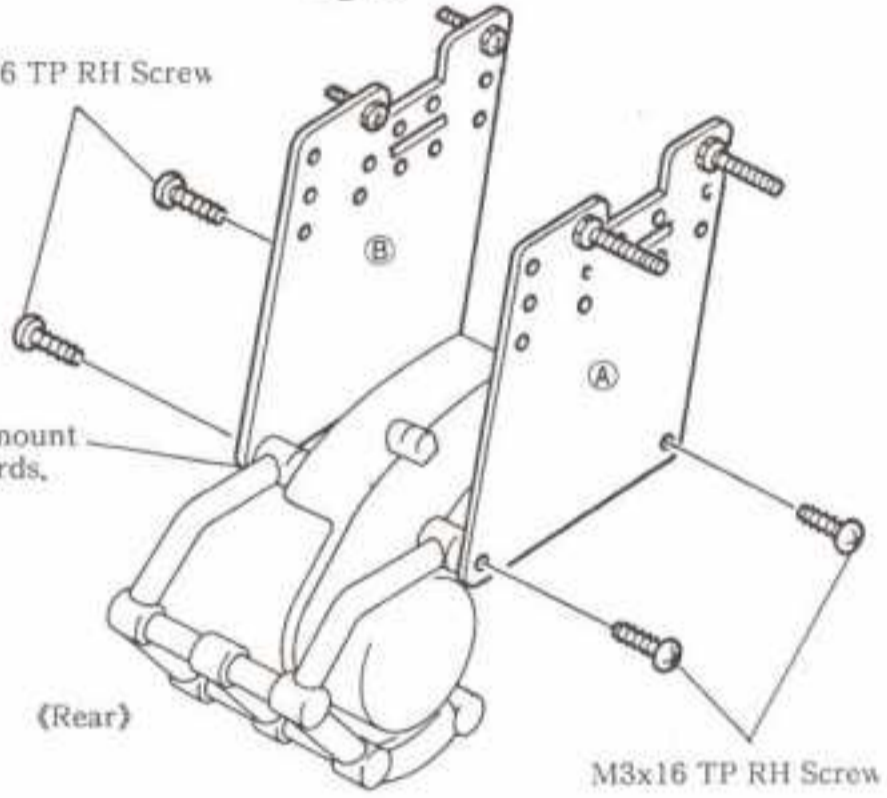

20 INSTALLATION OF SHOCK

M3 Nylon Nut 8
74 Rubber Pipe 8

* Install Front & Rear Shocks.



74 Rubber Pipe
Cut pipe to size, in 8 pieces.

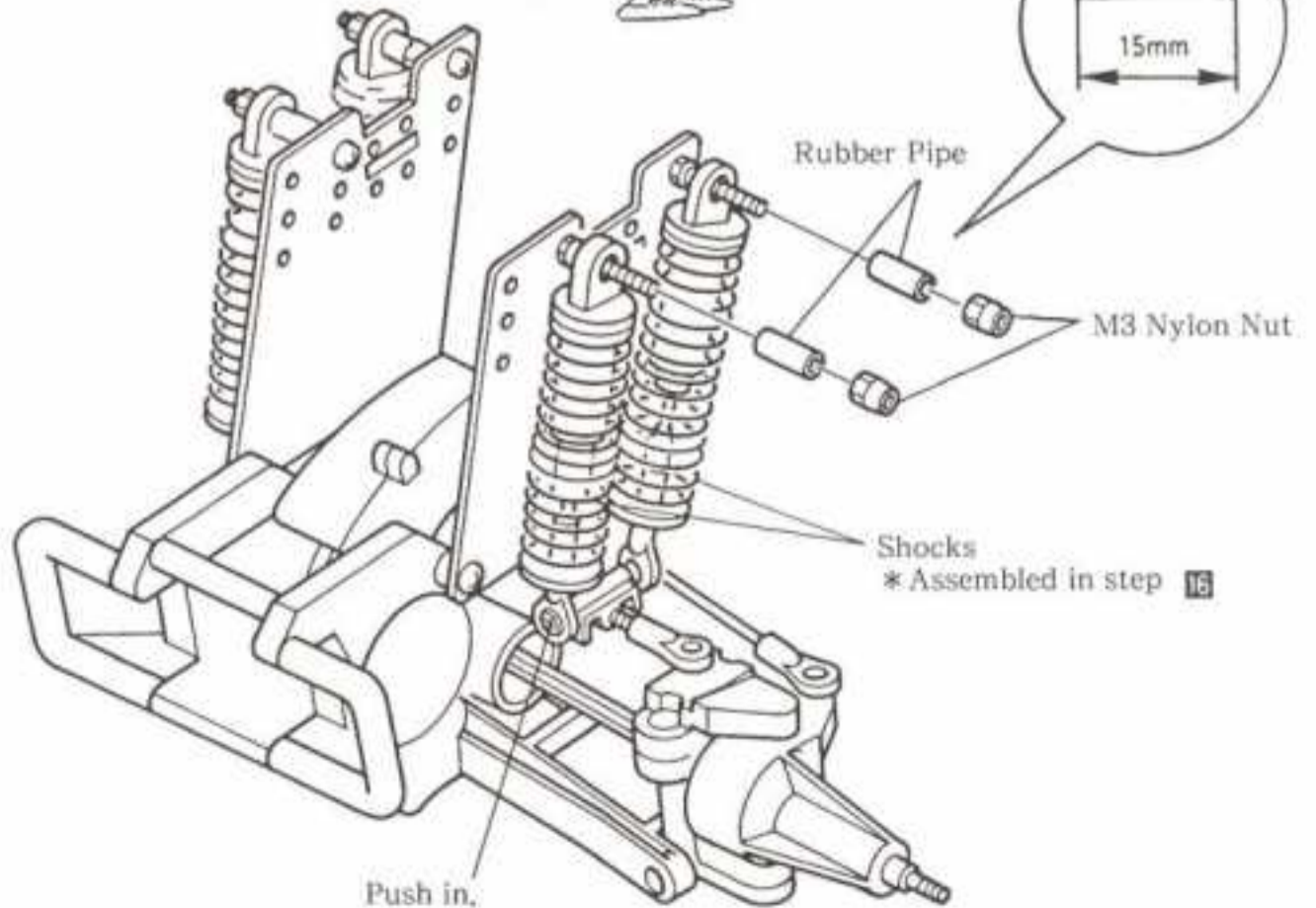
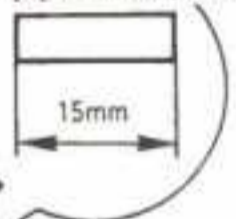

21 INSTALLATION OF BATTERY GUARD

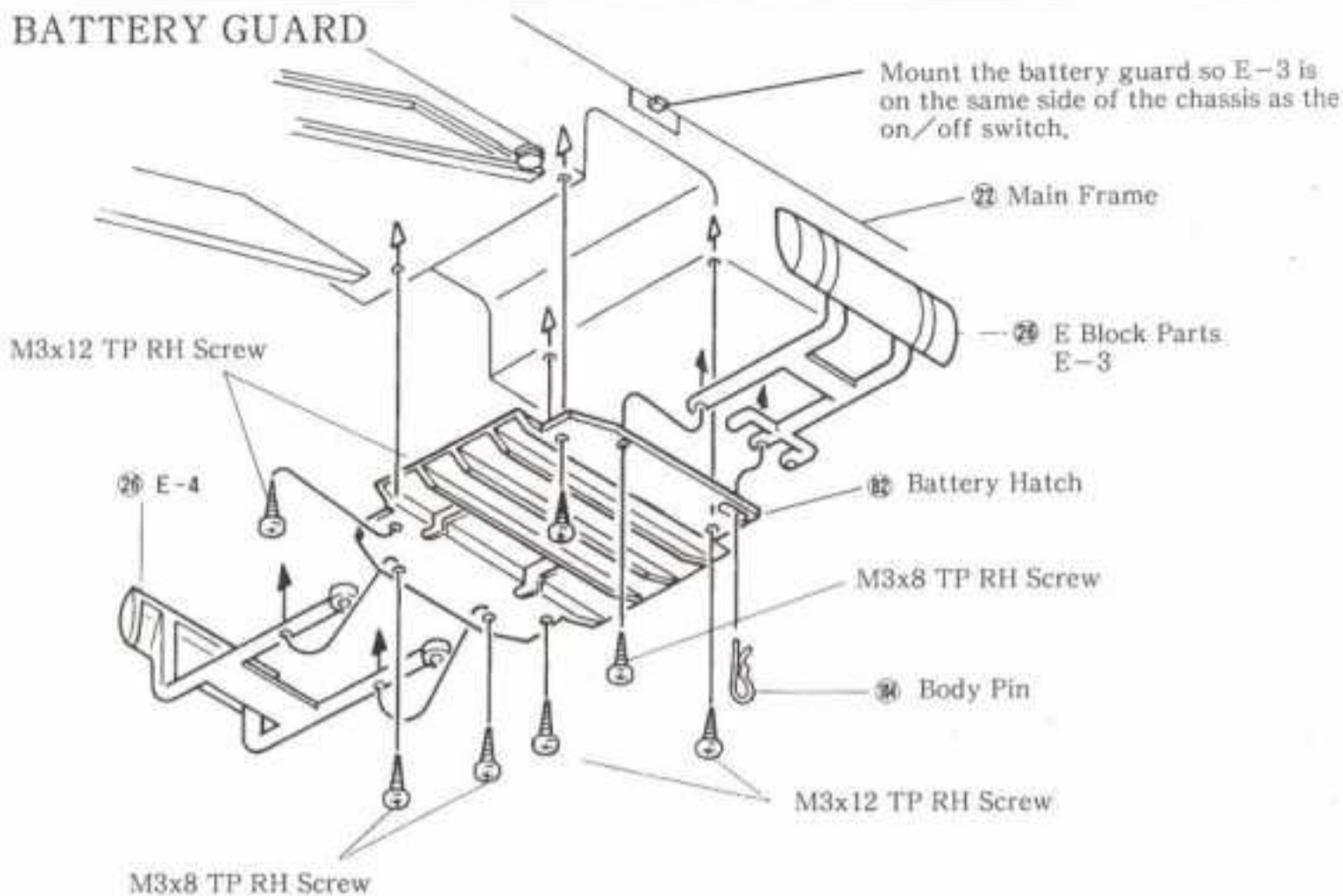

M3x12 TP RH Screw4

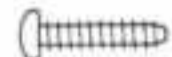

M3x8 TP RH Screw3



Body Pin1



22 INSTALLATION OF MOTOR

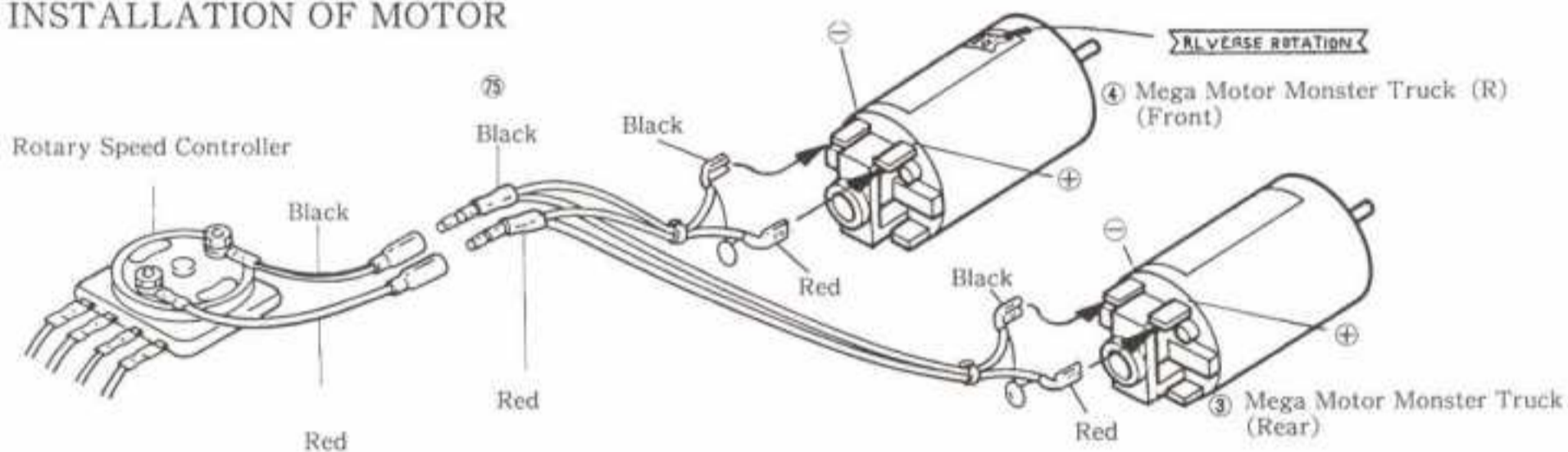

*NOTE: The front motor turns in the opposite direction than the rear so do not switch them.

Insert motor leads through here.

Motor Cover

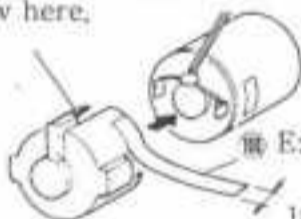

Trim the motor cover on the cut out line.

Mega Motor Monster Truck (R) Front

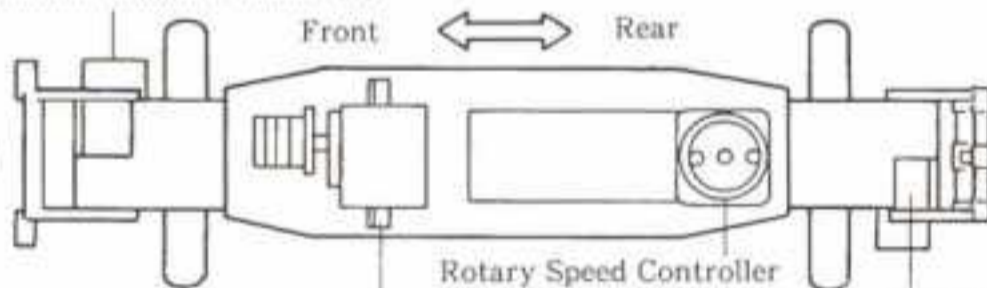

Steering Servo

Mega Motor Monster Truck (R) Rear

M3x12 TP RH Screw4

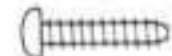

M3x28 RH Screw4



M3 Washer4



M3x3 Set Screw2



Pinion Gear 11T2

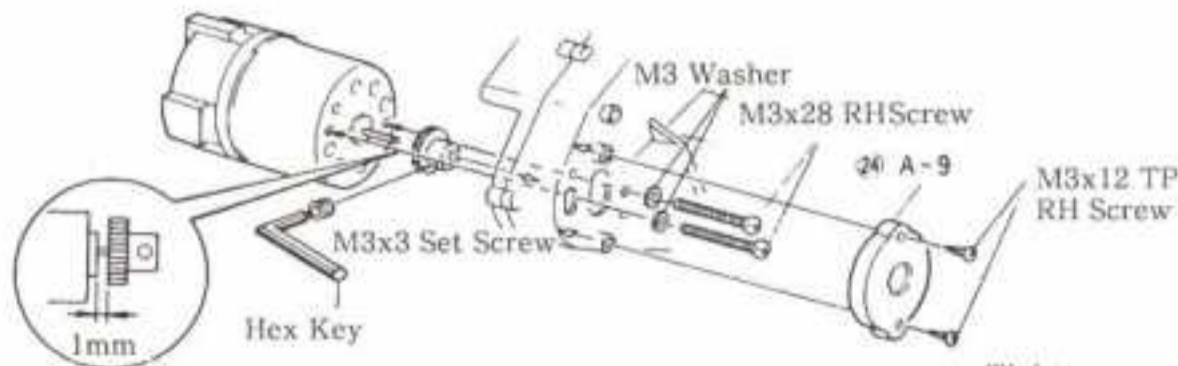
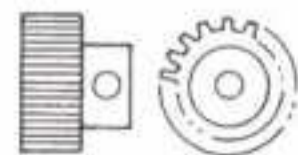

Leave 1mm gap between the motor and pinion gear.

Backlash Adjustment

Too Tight X Correct O Too Loose X



Tighten

Loosen

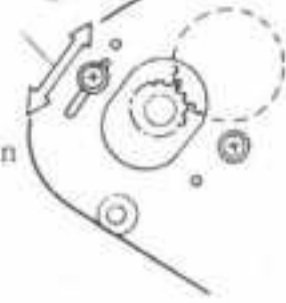

23 INSTALLATION OF COVER

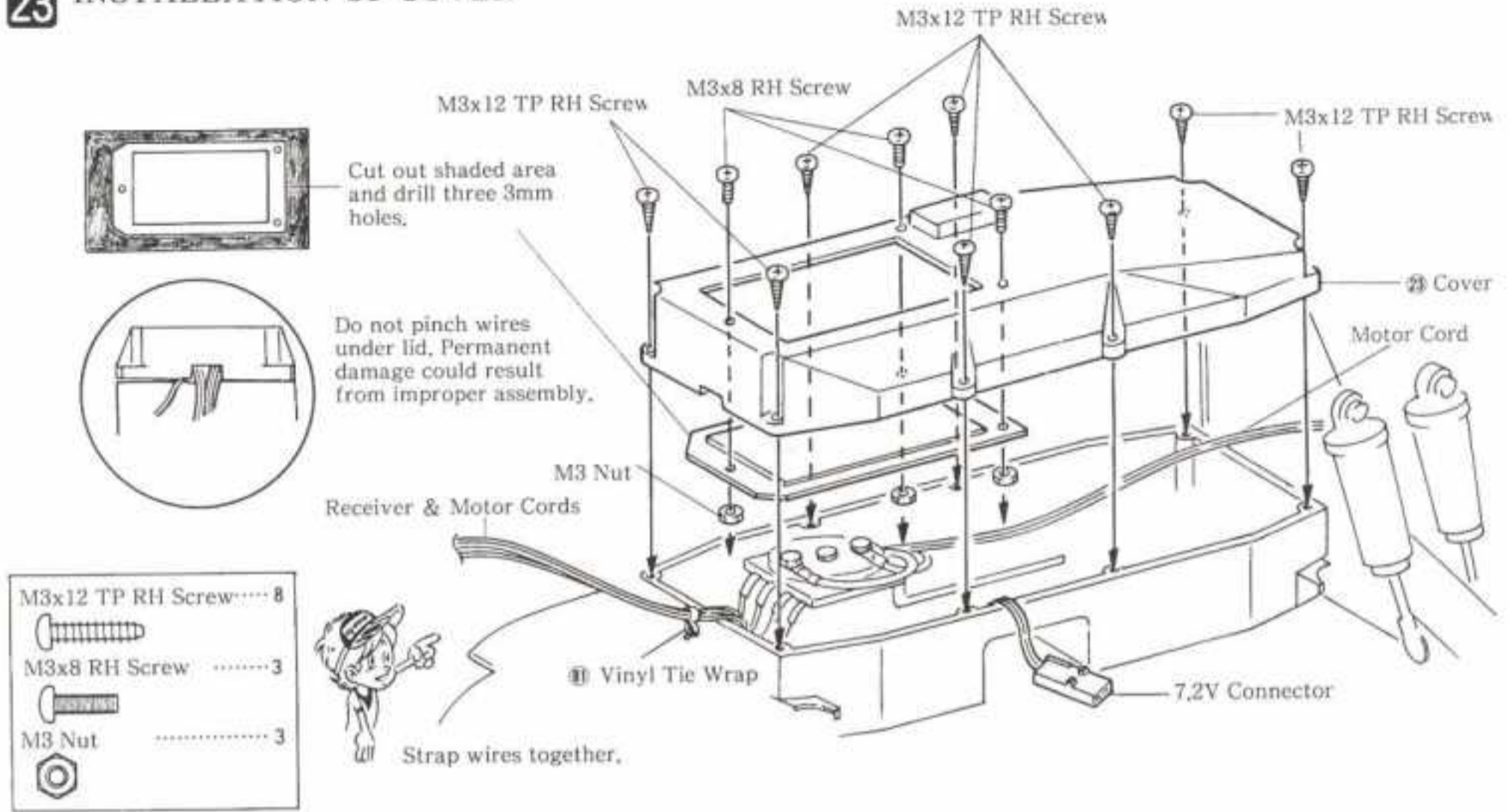

24 ASSEMBLY OF CARBURETOR

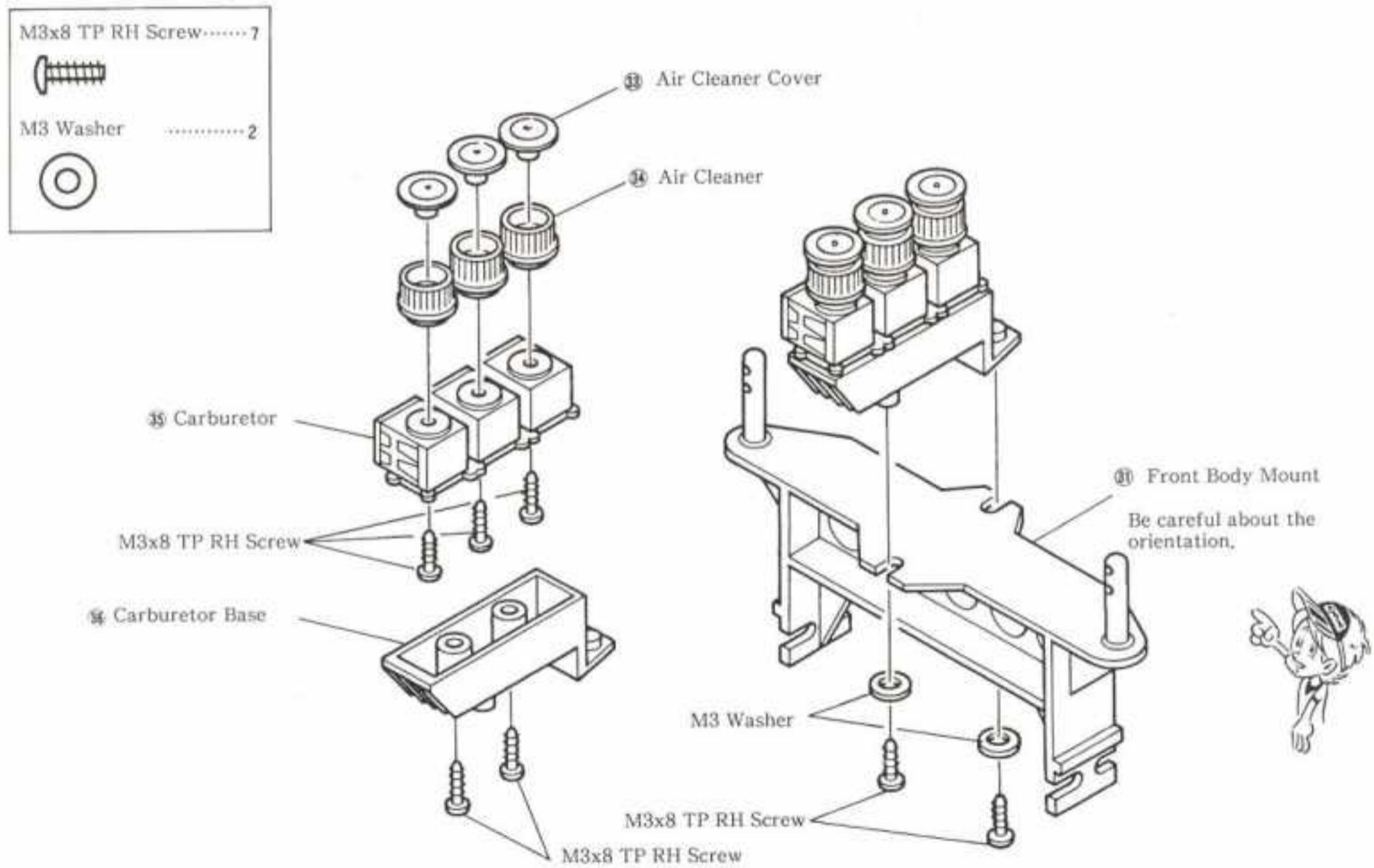

25 INSTALLATION OF BODY MOUNT

M3x12 RH Screw 8



M3 Flange Nut 8

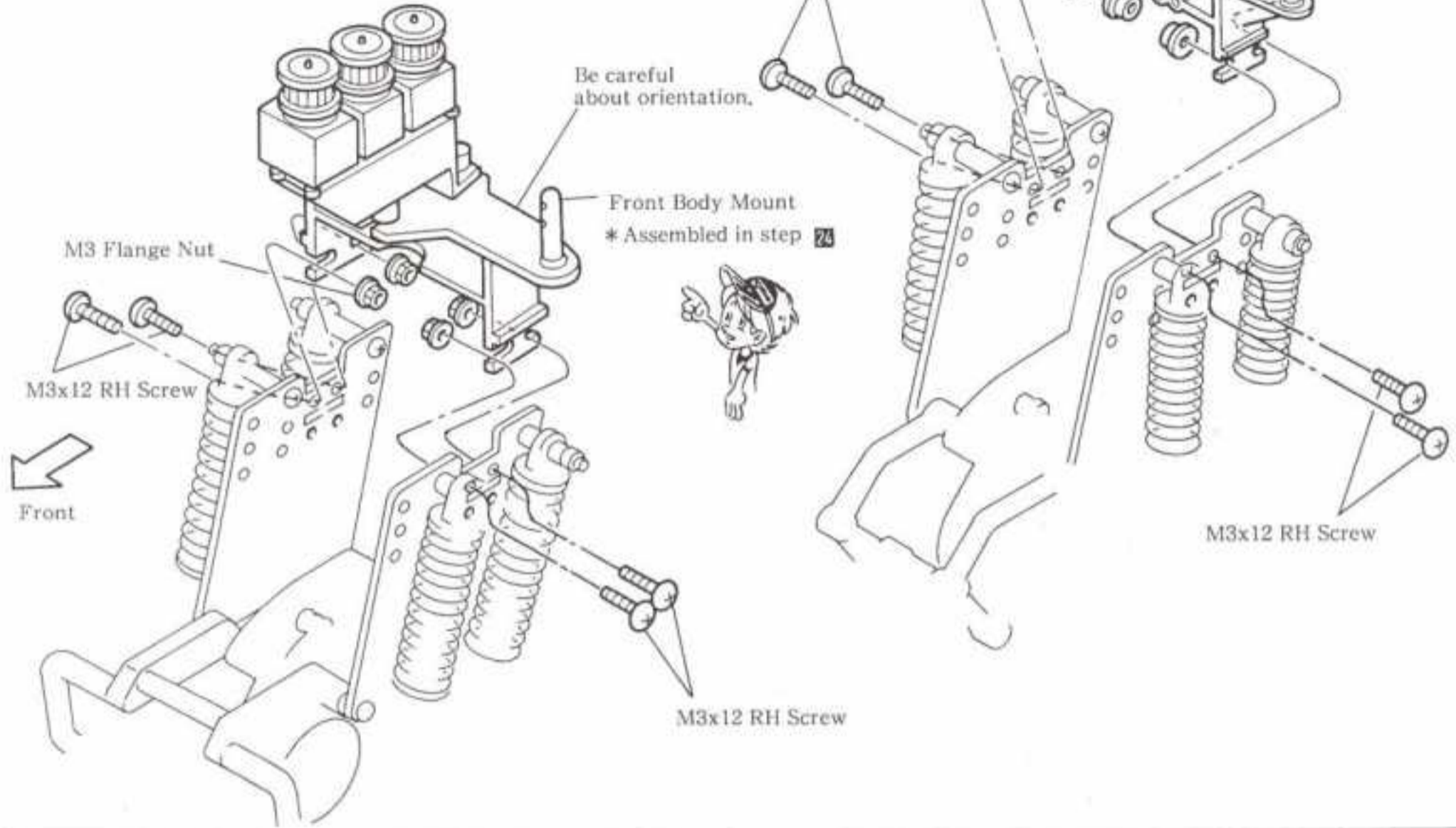

26 INSTALLATION OF RESISTOR AND ANTENNA

M3x8 TP RH Screw 3

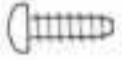

M2x10 RH Screw 1



Put them gently so that the terminals will not bend,

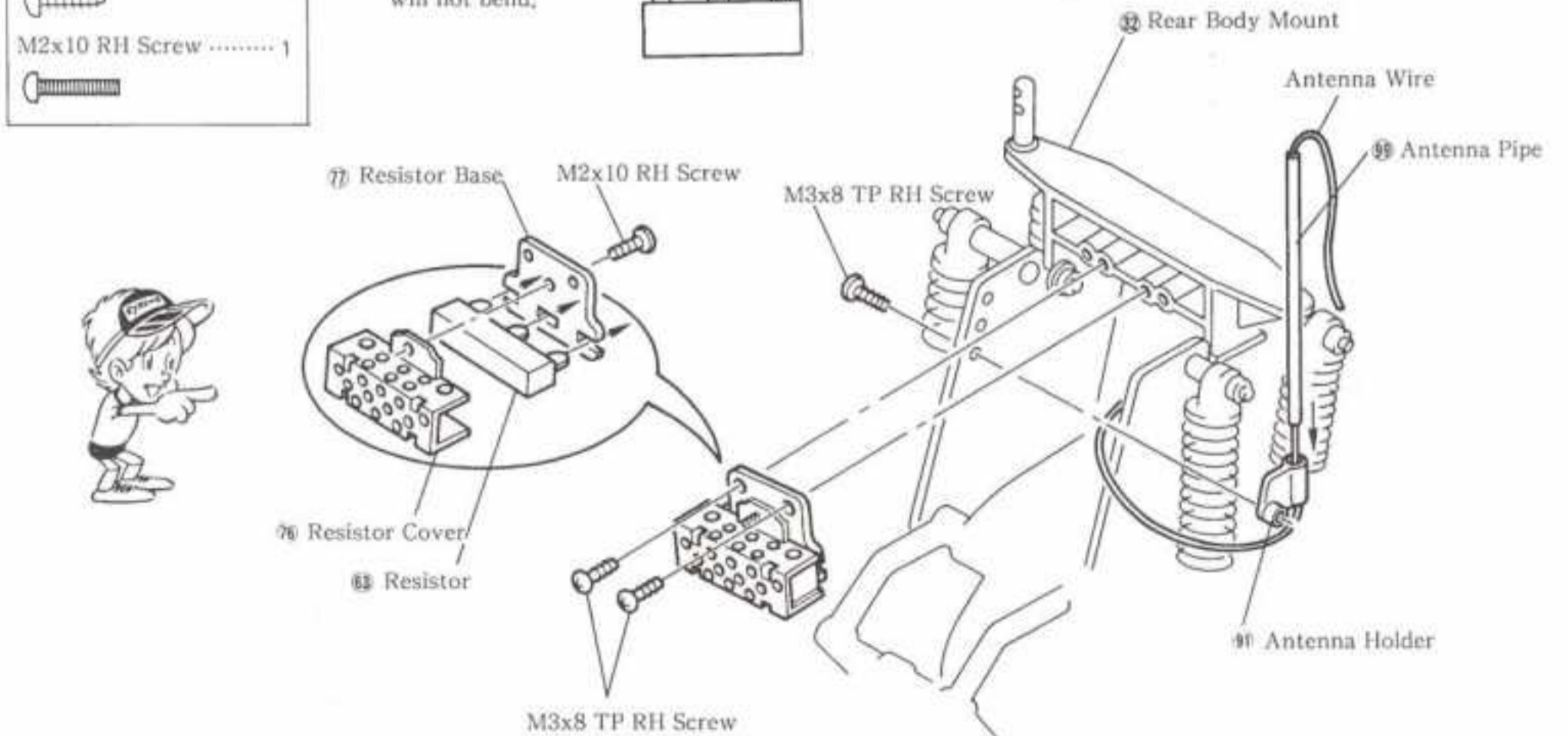
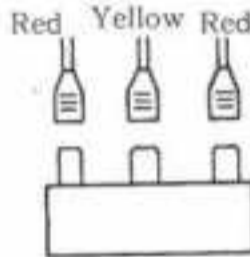

27 INSTALLATION OF TIRE

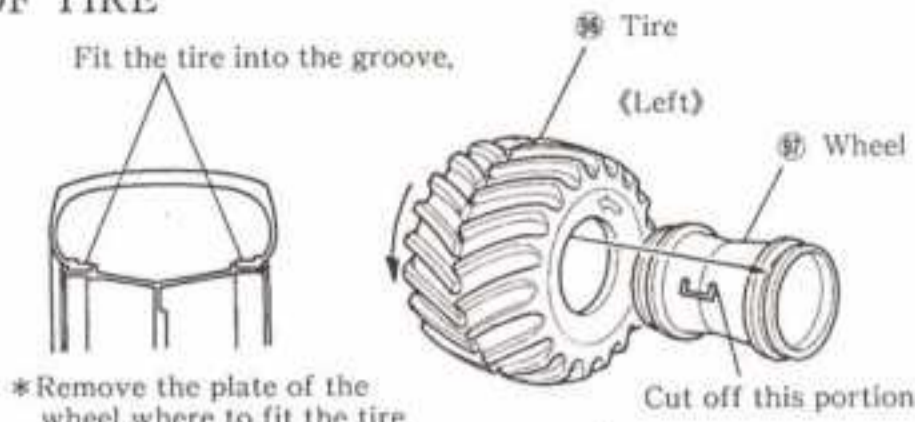
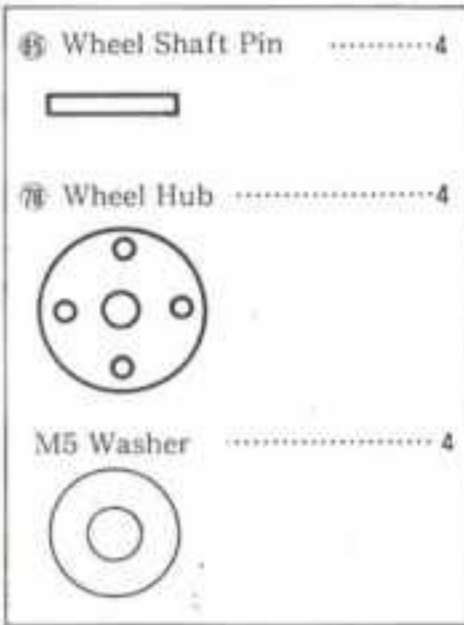

* Remove the plate of the wheel where to fit the tire.

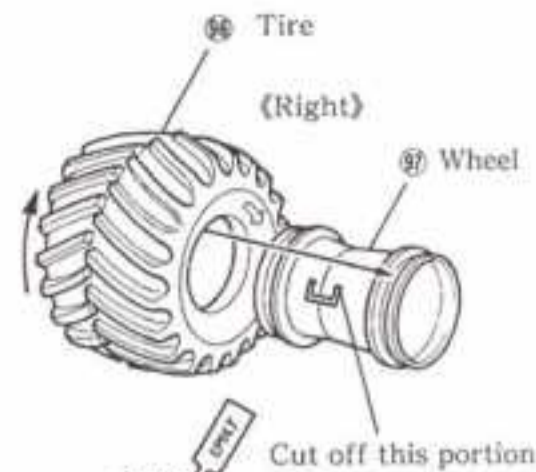

Cut off this portion



Apply instant glue along the seam.

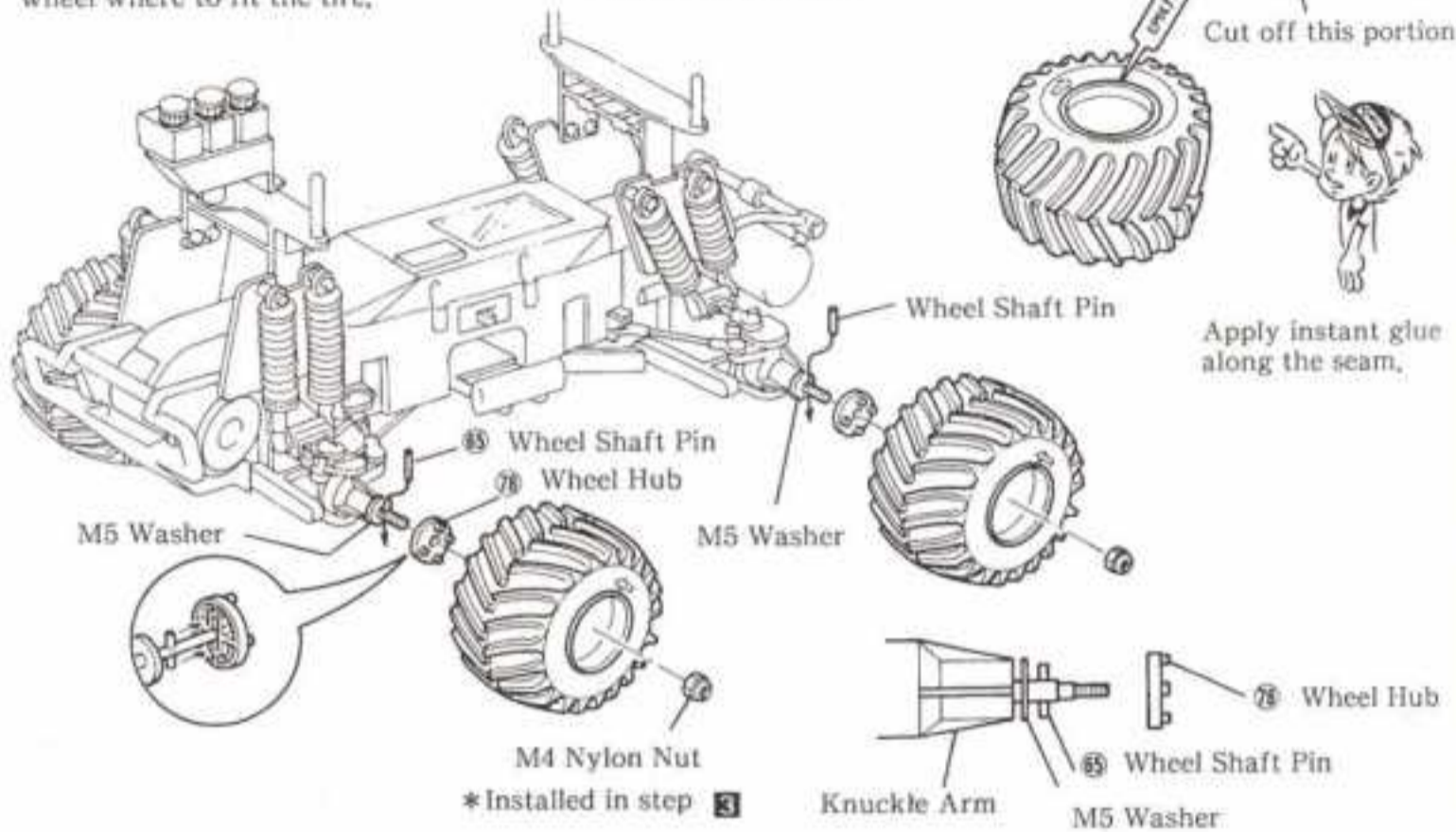

* Installed in step 3

Align the groove on the hub with the pin and insert the hub onto the shaft. Mount the hub over the pin.

28 CUTTING AND PAINTING BODY

Carefully remove the shaded area along the cut-out line as shown.

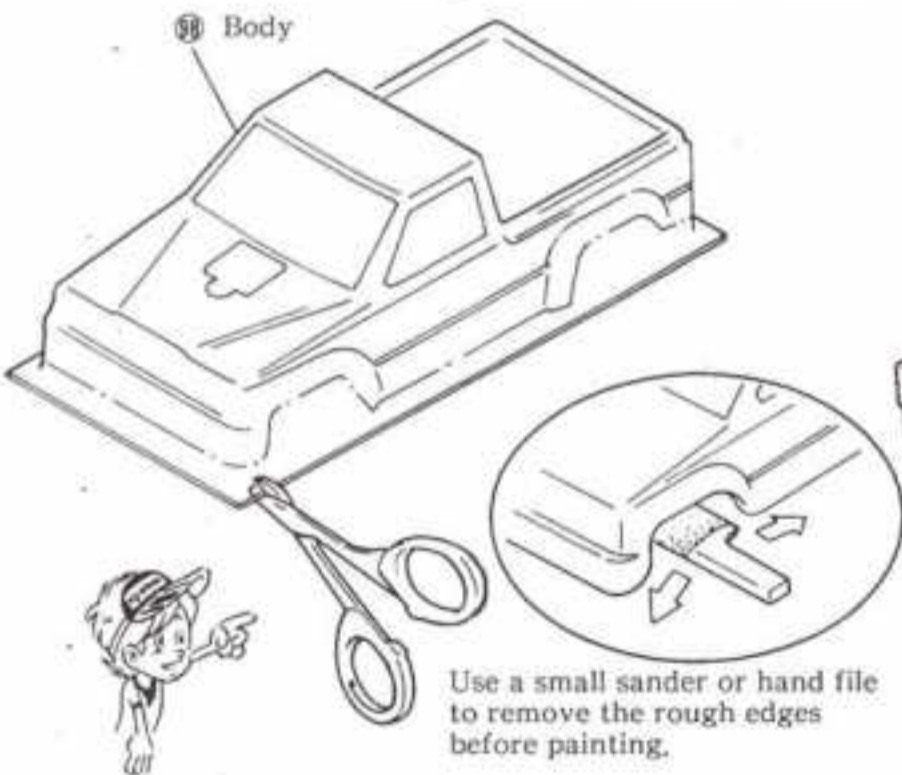

Use a small sander or hand file to remove the rough edges before painting.

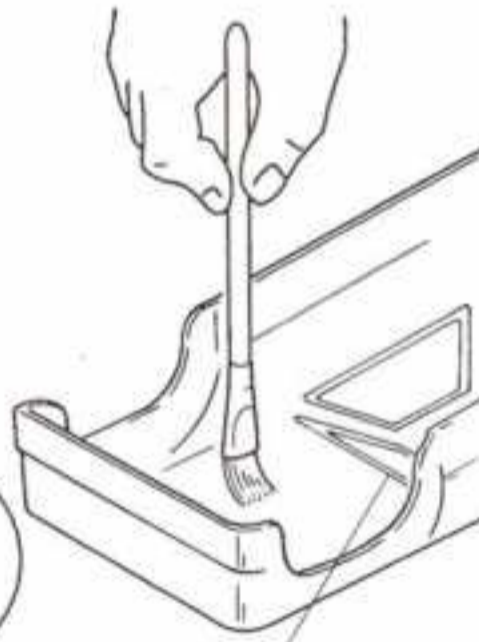

Mask the inside of the body along with the window design with the Micron Line Tape and Paint the inside.

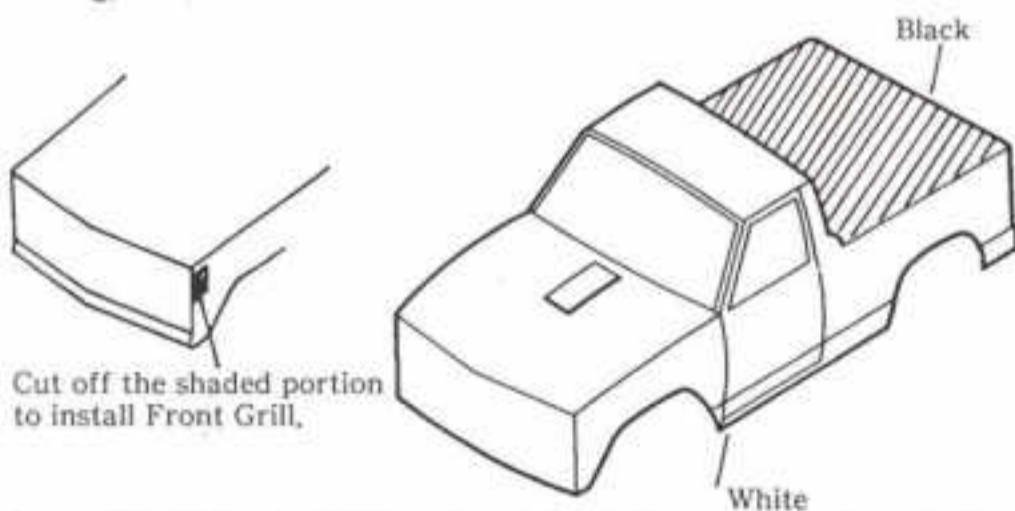

Cut off the shaded portion to install Front Grill.

First wash the body to remove any oil or dirt. Rinse thoroughly. Paint the inside of the body. You can obtain a nice color scheme by masking a portion with tape then removing the tape and painting with a different color.

Round Cutter & Sander

KYASHA No.1829

These special Lexan Scissors make trimming bodies a breeze and the sander comes in handy for finishing the rough edges.

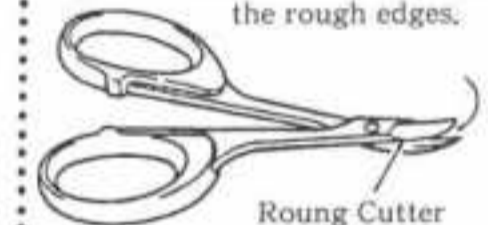

Micron Line Tape

KYASHA

No.1841...1mm
No.1842...1.5mm
No.1843...2.5mm

Color
White, Red, Yellow
Blue, Green, Black



Polyca Color Paint

KYASHA No.2230

Color
White, Red, Yellow
Green, Blue, Skyblue
Orange, Black, Violet
F.Pink, F.Orange and
Yellow Green



29 ASSEMBLY OF ROLL BAR

*Install Roll Bar Back Stay (R) & (L) first.

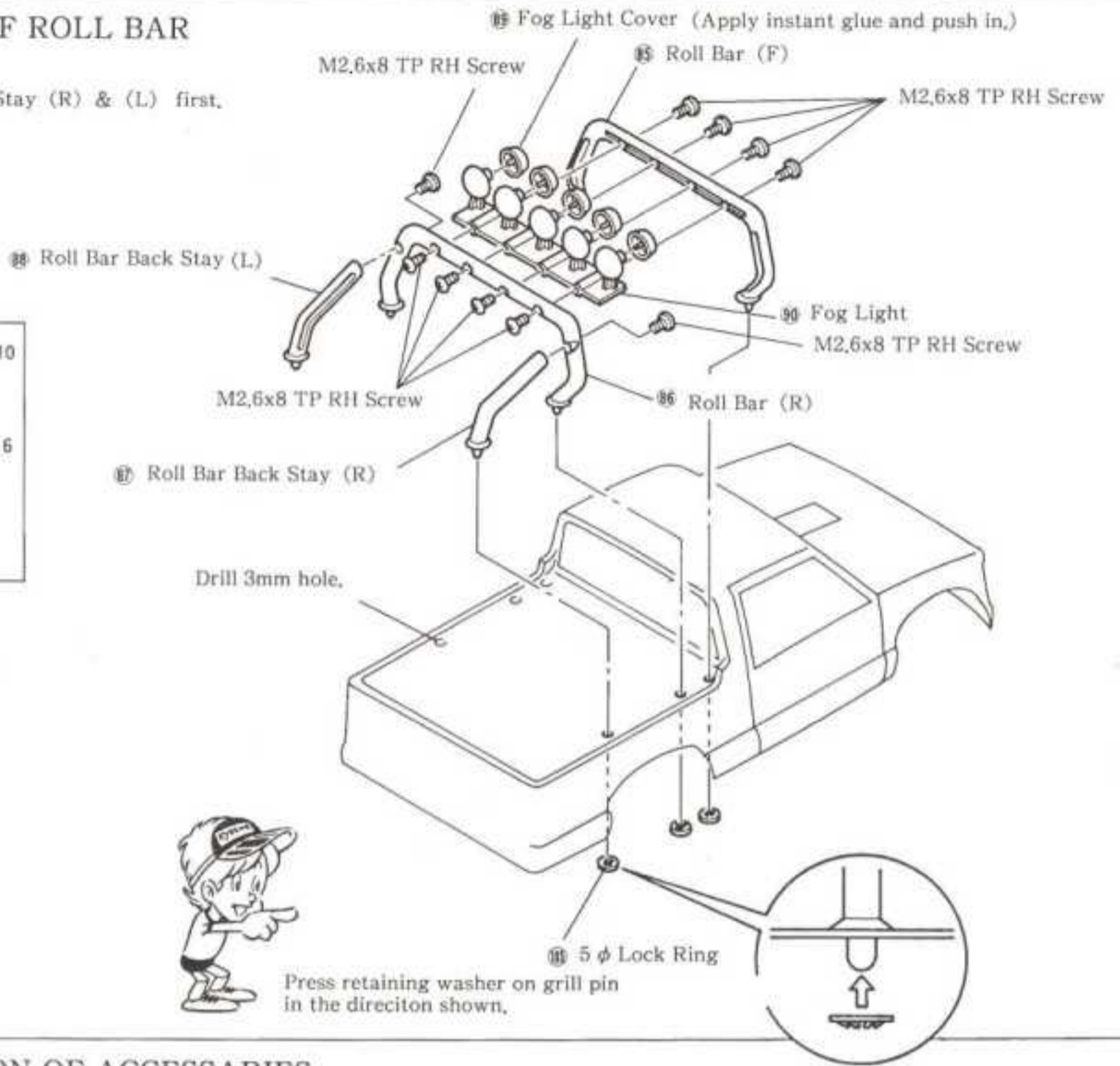

30 INSTALLATION OF ACCESSORIES

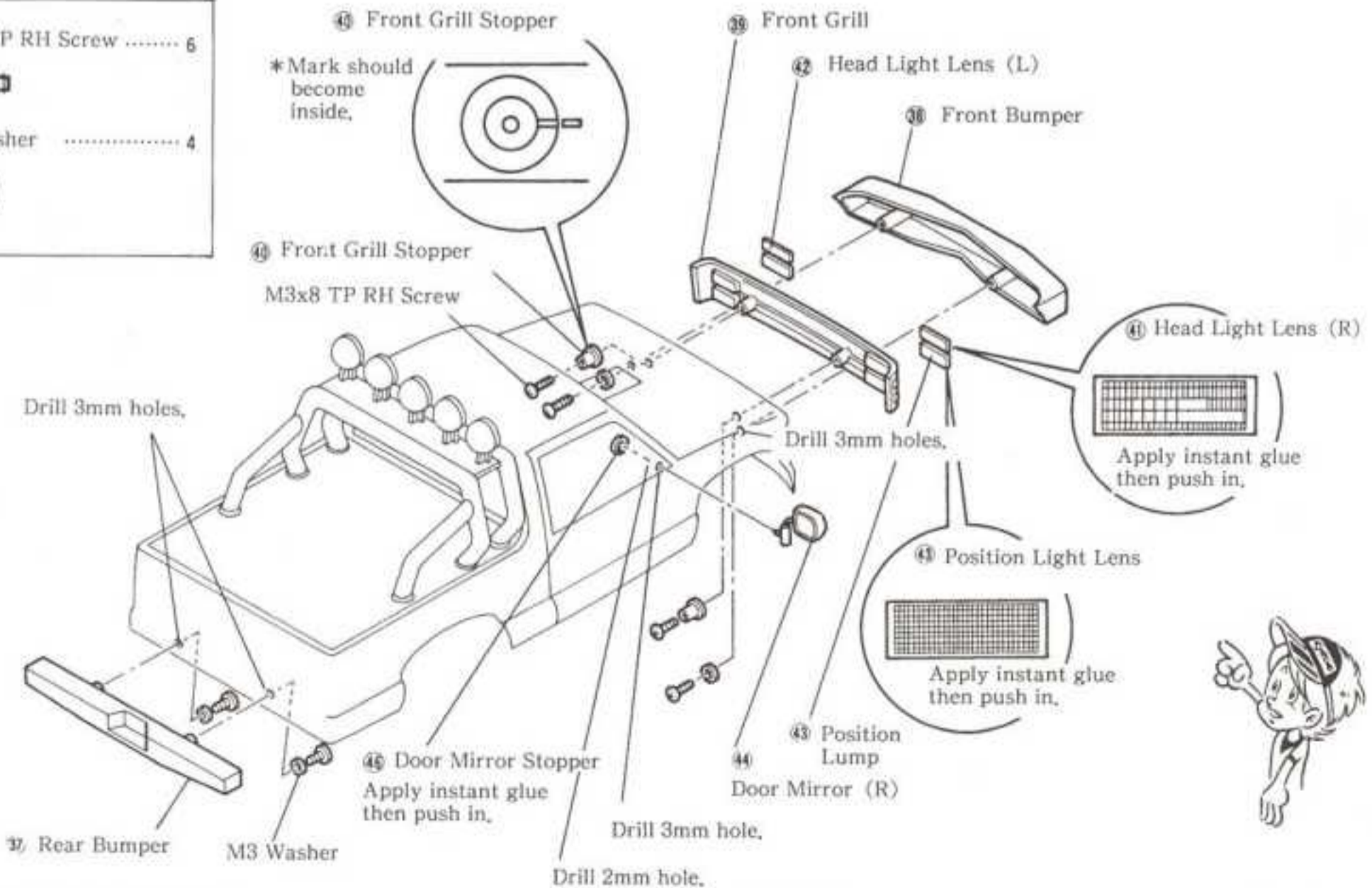
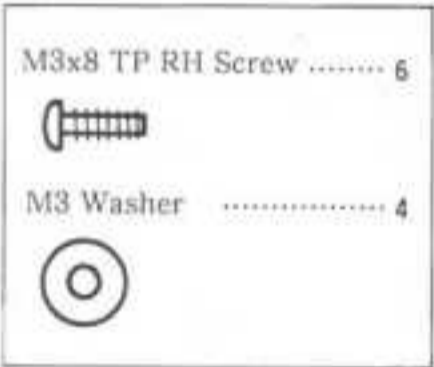

31 APPLYING DECAL

Cut off the decals along the cutout line with scissors. Convince yourself of the position by trying the decals with the backing paper on. Be careful not to have air bubbles left.

*Cut out Mirror Seals and cement to the the door mirror (R) & (L) installed in step 30

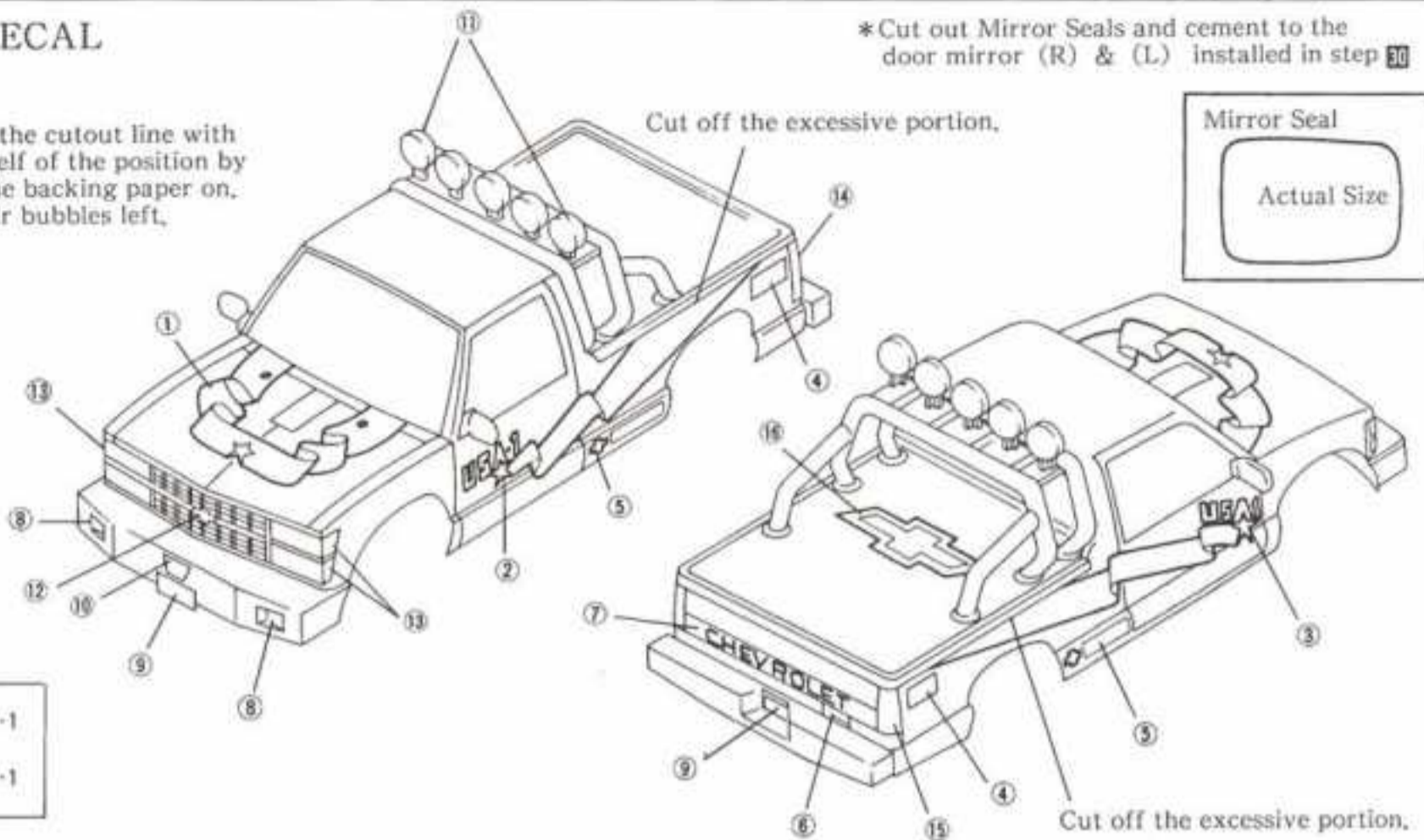

- ① Decal1
- ② Mirror Seal1

32 INSTALLATION OF BATTERY

Install in order ① ~ ⑥

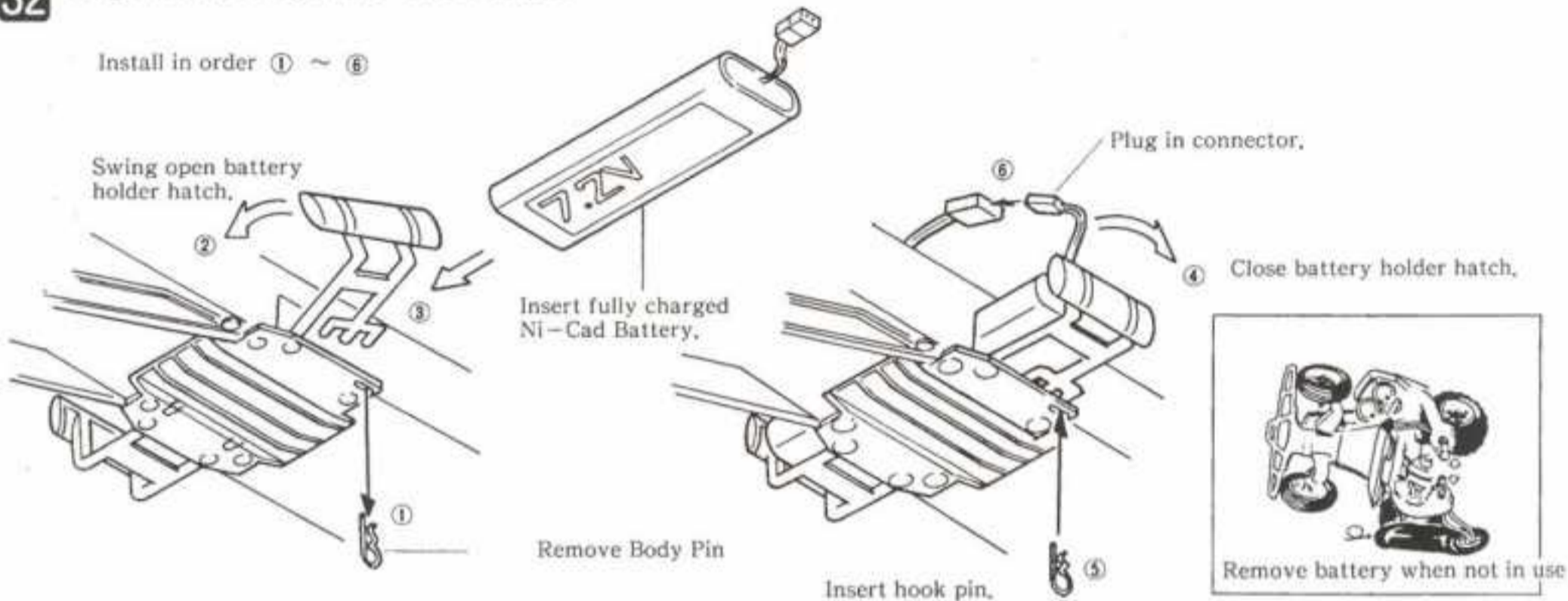

33 BODY MOUNTING

- ① Body Pin4
- ② Hook Pin4

*Put the hook pins under body before mounting.

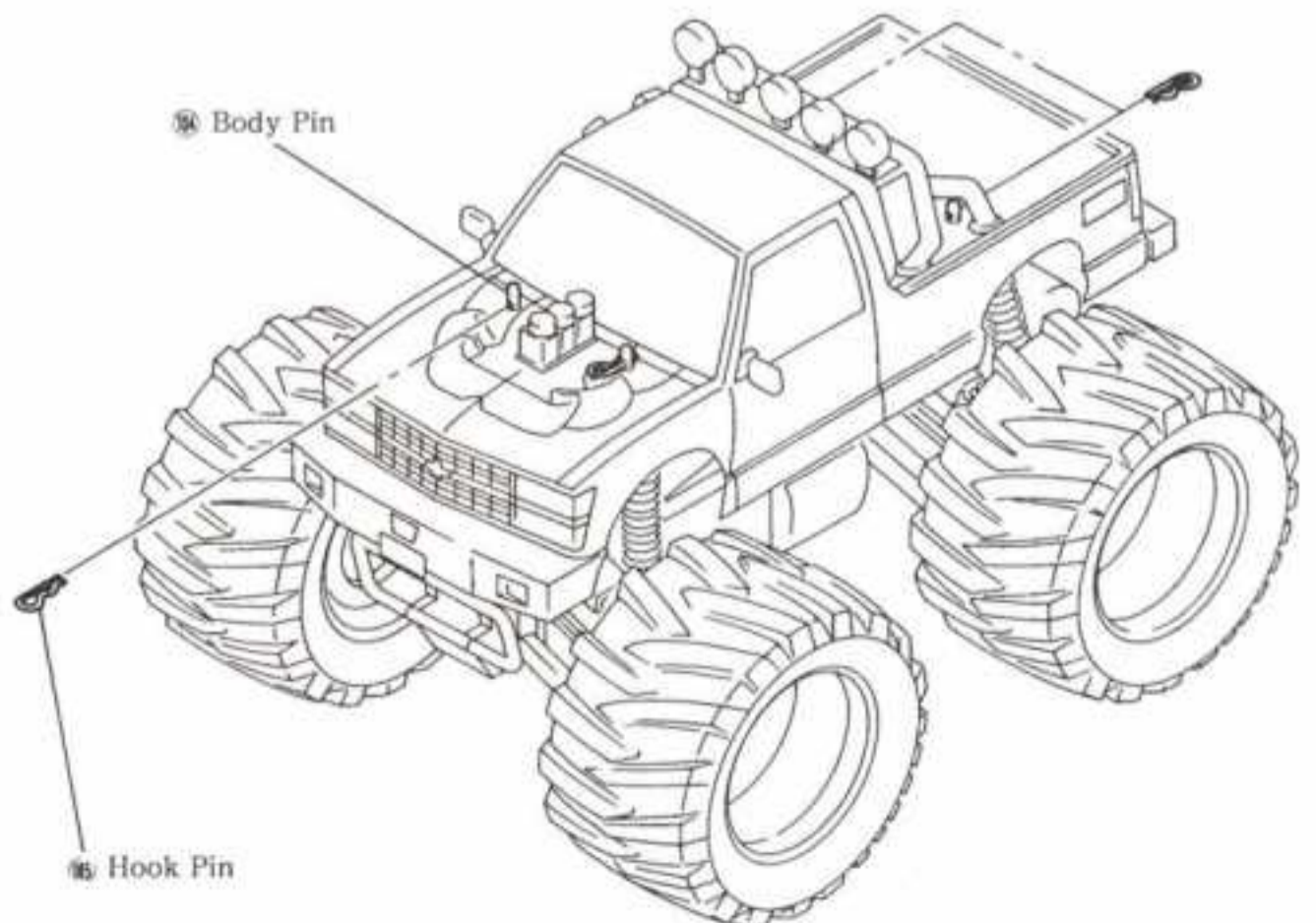

BASIC ADJUSTMENT GUIDE FOR THE U.S.A. - 1

(Speed Controller Adjustment)

Plug in the connector from the speed controller to the 7.2V Ni-Cad battery and operate your radio. While adjusting, the wheel of car may start to run, so keep your model upon a small box to make the wheels aloof from the ground.

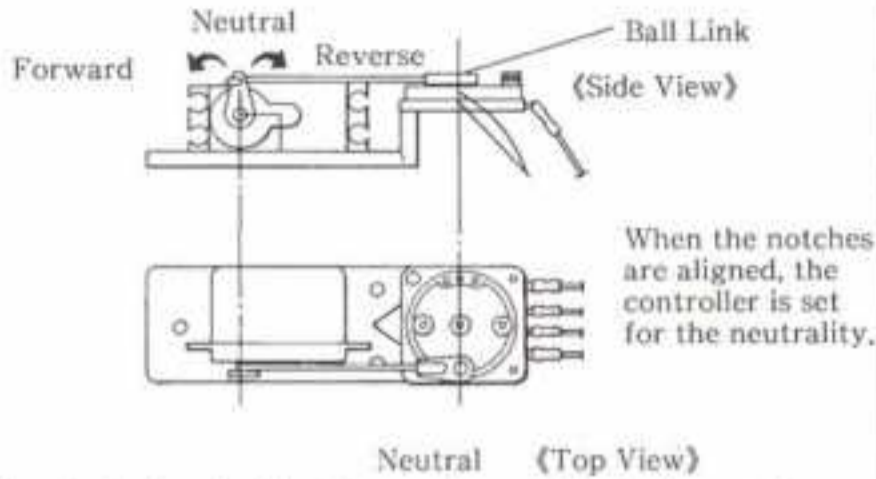

By turning the ball end, adjust the speed controller to the position shown in the drawing above (motor stopped position) with control stick and the trim lever in neutral.

① High Speed Adjustment

When the control stick on your radio is pushed forward all the way, the controller should be activated and the motor should run at a high speed. By the motor sound, you can tell if the motor is running high, medium, or low speed.

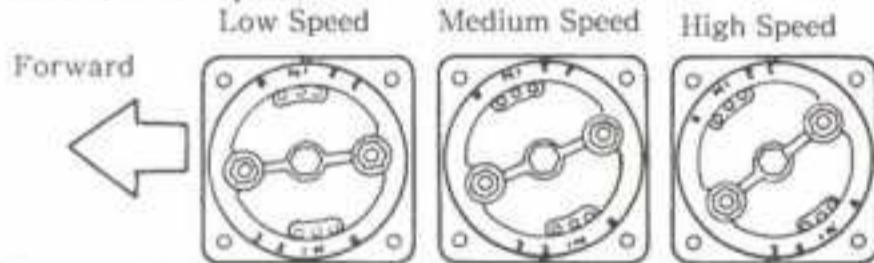

② Reverse Adjustment

Pull the control stick and control horn should operate as illustrated in the diagram below. The motor should run in reverse.

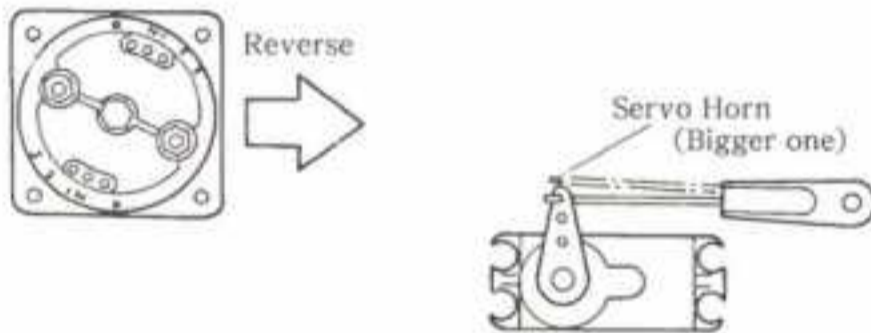

If the movement described in ① and ② are not achieved, replace the servo horn with a bigger one.

(Toe-in Adjustment)

Proper toe-in adjustment is necessary if the U.S.A. - 1 is expected to perform properly and drive in a straight line without any wandering tendencies.

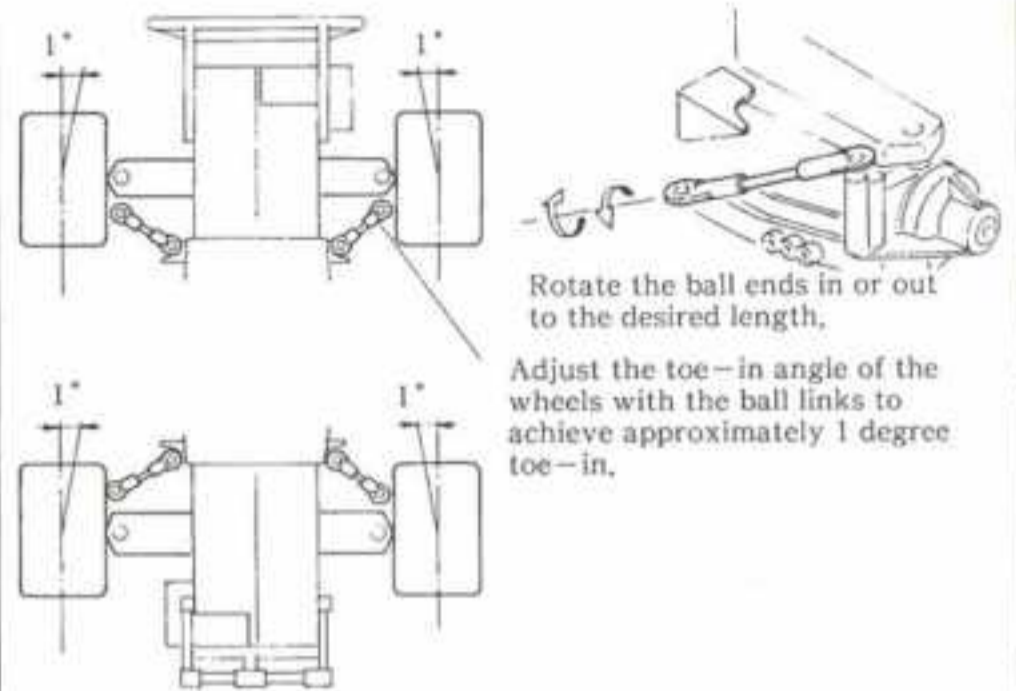

(Steering Adjustment)

To check wheel alignment put the truck on a box to allow wheels to move freely. Then operate the throttle and steering controls and make any adjustments.

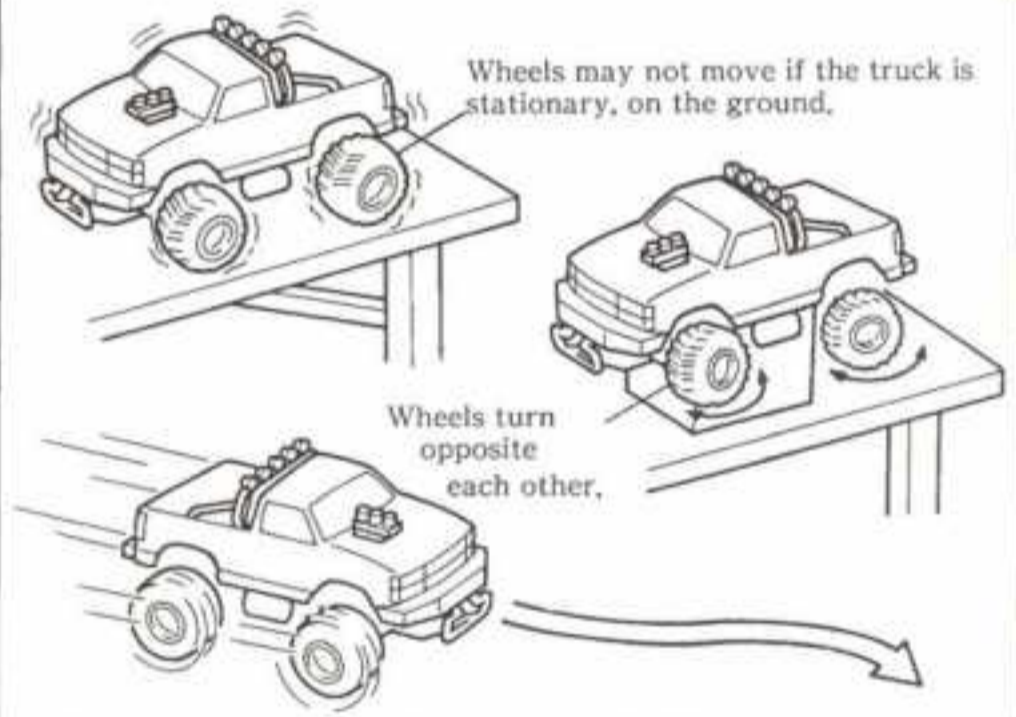

*Do not run the U.S.A. - 1 for long periods of time in the slower speeds or in reverse as this may cause overheating damage to the speed control resistor.

MAINTENANCE OF ROTARY SPEED CONTROLLER

(Checking Speed Controller)

- ① Check to see if the center nut or the lead fixing nuts are not loosen.
- ② Check to see if the lead cords do not rub against the rotor or the center nut when the speed controller is in operation, as a result the points on the controller may be out of contact.
- ③ Or the lead may come in contact with the body and causing the same trouble as stated above in ②.
- ④ Check to see if the speed control rod does not rub against a lead fixing nut.

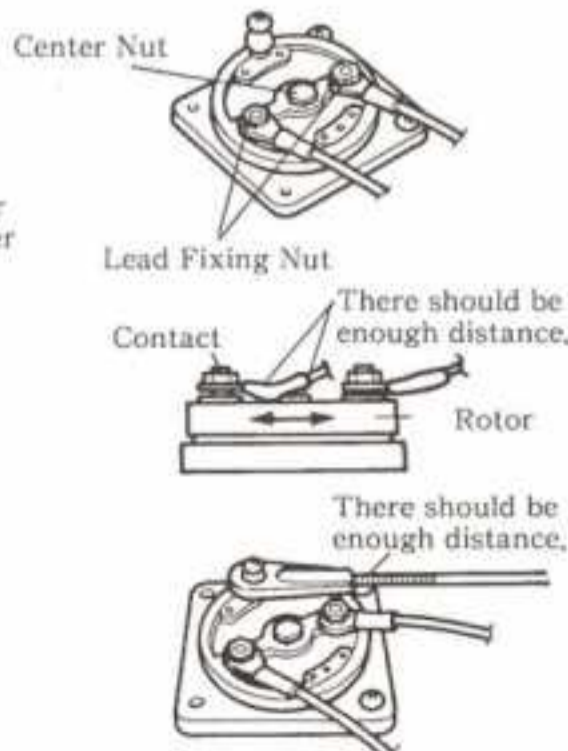

(Maintenance)

- ① Remove the center nut from time to time to check to see if anything in the controller. Clean it, if any.
- ② Make it a rule to check all points from ① to ④ (Checking Speed Controller), before running the car.

*If you notice the motor running intermittently or unsmoothly, examine those four checking points. If you find nothing defective, the controller may be worn out. (In such a case, the surface of the controller plate becomes rough.)

PARTS LIST

Key No.	Parts Name	Q'ty	Key No.	Parts Name	Q'ty	Key No.	Parts Name	Q'ty
①	Rotary Speed Controller	1	⑤①	Diff. Carrier	2	⑨⑧	Decal	1
②	Wheel Shaft	4	⑤②	Diff. Bevel Gear	6	⑨⑨	Mirror Seal	1
③	Mega Motor Monster Truck	1	⑤③	Z Block Parts	1	⑩②	Grommet	2
④	Mega Motor Monster Truck (R)	1	⑤④	5.8 φ Ball Link	20	⑩⑤	5 φ Lock Ring	6
⑤	Pinion Gear	2	⑤⑤	Idle Gear Shaft	2	⑩④	Body Pin	5
⑥	Resistor	1	⑤⑥	Idle Gear Shaft Pin	2	⑩⑤	Hook Pin	4
⑦	Shock Spring	8	⑤⑦	Diff. Joint Shaft	2	⑩⑥	E Ring (E4)	8
⑧	5.8 φ Pillow Ball	20	⑤⑧	Counter Gear Shaft	2	TP RH Screw	M2 × 6	18
⑨	Gear Box (A)	2	⑤⑨	Sus. Shaft (A)	4	"	M2 × 10	1
⑩	Gear Box (B)	2	⑥⑥	Sus. Shaft (B)	4	"	M2.6 × 8	10
⑪	Knuckle Arm (A)	2	⑥①	Sus. Shaft (C)	4	"	M3 × 8	49
⑫	Knuckle Arm (B)	2	⑥②	M3 Rod (for Tie Rod)	4	"	M3 × 12	52
⑬	Rear Hub Carrier (Upper)	2	⑥③	M3 Rod (for Upper Sus. Arm)	4	"	M3 × 16	16
⑭	Rear Hub Carrier (Lower)	2	⑥④	Shock Shaft	8	RH Screw	M2 × 10	2
⑮	Front Hub Carrier R (Upper)	1	⑥⑤	Wheel Shaft Pin	4	"	M3 × 8	5
⑯	Front Hub Carrier L (Upper)	1	⑥⑥	Shock Tower	4	"	M3 × 12	12
⑰	Front Hub Carrier R (Lower)	1	⑥⑦	4 φ x8 Metal Bushing	8	"	M3 × 25	8
⑱	Front Hub Carrier L (Lower)	1	⑥⑧	5 φ x10 Metal Bushing	8	"	M3 × 28	4
⑲	Knuckle Arm Washer	8	⑥⑨	8 φ x12 Metal Bushing	4	"	M3 × 60	1
⑳	Counter Gear Bushing	2	⑦⑩	4.5 φ Ball	1	Set Screw	M3 × 3	2
㉑	Half Shaft	4	⑦①	4.5 φ Ball Link	1	Nut	M2	1
㉒	Main Frame	1	⑦②	Speed Control Rod	1	"	M3	11
㉓	Cover	1	⑦③	Double Sided Tape	1	Flange Nut	M3	14
㉔	A Block Parts (A3,4,5A,5B,6,9,10)	2	⑦④	Rubber Pipe	4	Nylon Nut	M3	9
㉕	C Block Parts	4	⑦⑤	Motor Cord	1	"	M4	4
㉖	E Block Parts	1	⑦⑥	Resistor Cover	1	Washer	M3	20
㉗	Front Guard (A)	1	⑦⑦	Resistor Base	1	"	M5	4
㉘	Front Guard (B)	1	⑦⑧	Wheel Hub	4	"	M8	4
㉙	Front Guard (C)	1	⑦⑨	Grease	2	Cross Wrench		1
㉚	Front Guard Bar	1	⑧①	Torque Rod	1	Hex Key (1.5mm)		1
㉛	Front Body Mount	1	⑧②	Vinyl Tie Wrap	1			
㉜	Rear Body Mount	1	⑧③	Battery Hatch	1			
㉝	Air Cleaner Cover	3	⑧④	Window	1			
㉞	Air Cleaner	3	⑧⑤	Motor Cover	1			
㉟	Carbrator	1	⑧⑥	Roll Bar (F)	1			
㊱	Carbrator Base	1	⑧⑦	Roll Bar (R)	1			
㊲	Rear Bumper	1	⑧⑧	Roll Bar Back Stay (R)	1			
㊳	Front Bumper	1	⑧⑨	Roll Bar Back Stay (L)	1			
㊴	Front Grill	1	⑨③	Fog Light Cover	5			
㊵	Front Grill Stopper	2	⑨④	Fog Light	1			
㊶	Head Light Lens (R)	1	⑨⑤	Antenna Holder	1			
㊷	Head Light Lens (L)	1	⑨⑥	Servo Mount	1			
㊸	Position Light Lens	2	⑨⑦	Upper Sus. Arm	4			
㊹	Door Mirror (R)	1	⑨⑧	Lower Sus. Arm	4			
㊺	Door Mirror (L)	1	⑨⑨	A Block Parts (A1,2)	2			
㊻	Door Mirror Stopper	2	⑩①	Tire	4			
㊼	Diff. Joint	4	⑩②	Wheel	4			
㊽	Diff. Side Gear	4	⑩③	Body	1			
㊾	Idle Gear	2		Instruction Manual	1			
㊿	Counter Gear	2	⑩④	Antenna Pipe	1			

PURCHASING PARTS FOR YOUR KIT

You can purchase replacement and optional parts for your kit. All of the parts identified by key numbers are usually not available singularly, but we offer these parts in convenient parts "packs" which can be purchased separately. To figure out which parts pack you need, find the key number for that part within the manual.

Then consult our parts pack guide below. When referring to the parts you need, always use the Parts Pack Numbers. For instance, if you need an Wheel Shaft (key no.2) ask your dealer for Kyosho Parts Pack DA-26 (Wheel Shaft).

No.	Parts Name	Key No. & Q'ty
DA-1	Gear Box Set	①②×1
DA-3	Front Guard Set	③④⑤⑥⑦⑧×1
DA-8	A Block Parts	⑨⑩×1
DA-9	E Block Parts	⑪×1
DA-12	Motor Cord	⑫×1
DA-18 (DA-2)	Frame Set	⑬⑭⑮⑯×1
DA-19	Carbrator	⑰⑱×3 ⑲⑳×1
DA-20	Sus. Shaft Set	㉑㉒×2
DA-21	Rod Set	㉓㉔×2 ㉕㉖×4 ㉗×1
DA-22	Knuckle Arm	㉘㉙×2
DA-23	Hub Carrier Set	㉚㉛×2 ㉜㉝㉞㉟×1
DA-24	Half Shaft Set	㊱×8 ㊲×2 ㊳×4 ㊴×1
DA-25	C Block Parts (Black)	㊵×1
DA-26	Wheel Shaft	㊶×2
DA-27	Sus. Arm Shaft Set	㊷㊸×2
DA-28	Wheel	㊹×2
DA-29	Tire	㊺×2
DA-30	Accessory Set	㊻㊼㊽㊾㊿×1 ①②③④×2
DA-31	Roll Bar Set	⑤⑥⑦⑧⑨⑩×1 ⑪×5
DA-32	Shock Tower	⑫×2
DA-33	Metal Bushing	⑬⑭×8 ⑮×4
DA-34	Body U.S.A. - 1	⑯×1
DA-35	Decal U.S.A. - 1	⑰⑱×1
DA-36	Screw Set	㉑×2 ㉒×4 ㉓×1 Screws,Nuts,Wrench
BB-6	Gear Set	㉔㉕×2 ㉖㉗㉘×1 ㉙×3
BB-8	5.8 φ Ball Link Set	㉚×12 ㉛×12
BB-37	Shaft Pin	㉜×10
BB-39	Gear Shaft Set	㉝㉞㉟×1 ㊱×2
BB-42	Small Parts	㊲㊳㊴㊵㊶㊷㊸×1
BB-43	Wheel Hub	㊹×4
PG-37	Motor Cover	㊺×2
EP-22	Hook Pin	㊻×5

No.	Parts Name	key No. & Q'ty
1889	Body Pin	①×5
1831	Rotary Controller	②×1
1819	Resistor	③④⑤×1
DA-37	Pinion Gear (11T)	⑥×1 M3×3 Set Screw×1
2477	Mega Motor Monster Truckf	
2477R	Mega Motor Monster Truck (R)	
Optional Parts		
1903	Ball Bearing (φ4×φ8)	2 pcs.
1901	Ball Bearing (φ5×φ10)	2 pcs.
PI-15	Ball Bearing (φ8×φ12)	2 pcs.
WS002	Pressure Shock (L)	Constant Volume Type 2 sets.
WS004	Adjustable Shock (L)	Easy Adjusting 2 sets.
1951	Shock Oil (S,M,H)	For Oil Shock
OT38	Silicone Grease	For Gear & Metal Bushing
1883	Frontier Hobby Oil	
SC40	Motor Cover	Protect from dirt
NB13	Light Set	Light, Battery Box
1953	Silicone Oil (S)	For Oil Shock
1954	Silicone Oil (M)	*
1955	Silicone Oil (H)	*

The following optional parts are required to make "U.S.A. - 1" perfect with ball bearings.

No.1903 Ball Bearing ... 4 sets.

No.1901 Ball Bearing ... 4 sets.

No.PI-15 Ball Bearing ... 2 sets.

EXPLODED VIEW OF USA-1 MONSTER TRUCK

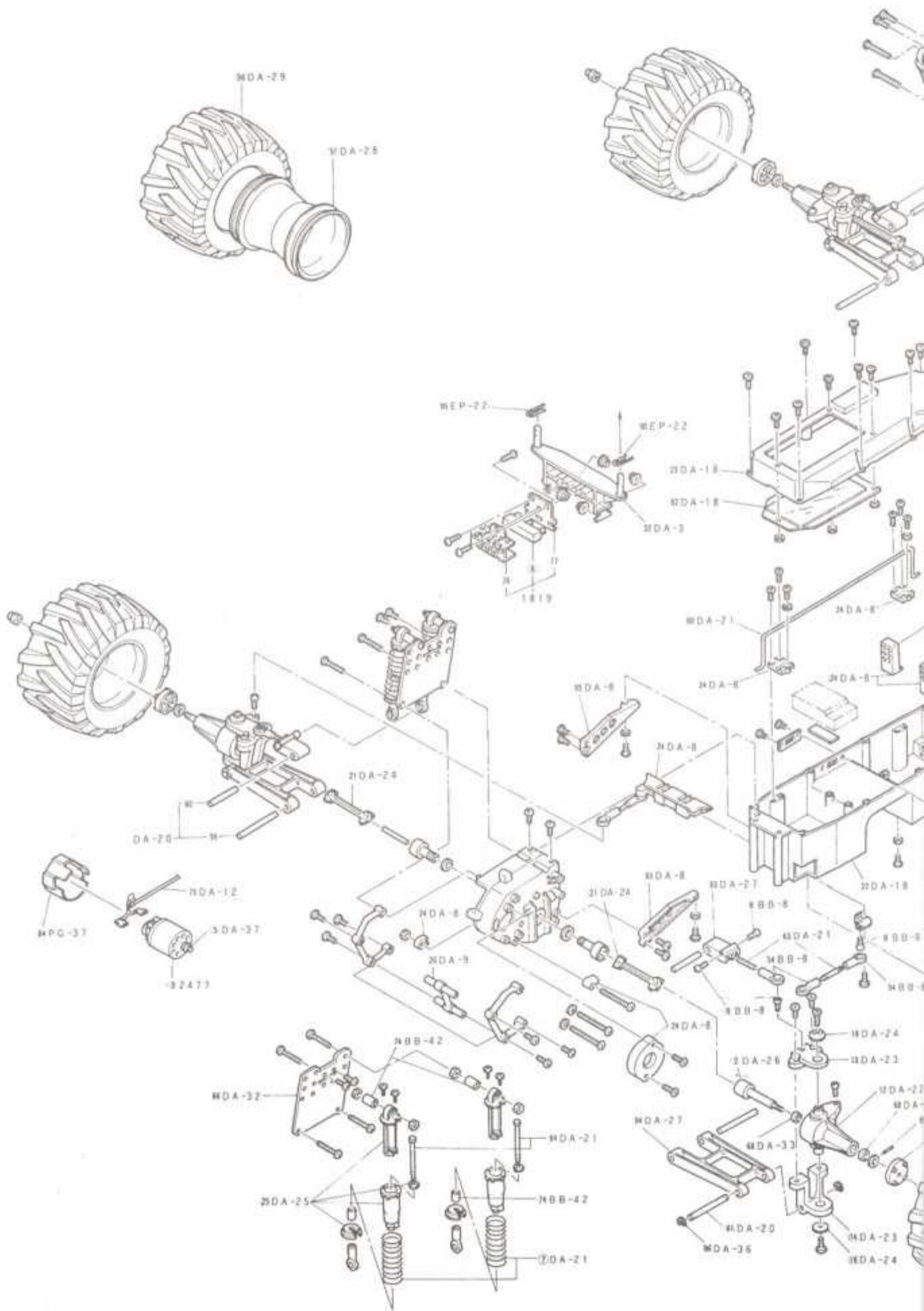

The Super Hobby



This products is not to be sold in the United States, If you have purchased this product in the United States, please contact Kyosho U.S.A. phone number (217) 398-3630.

PRINTED IN JAPAN