

RADIO CONTROLLED ELECTRIC POWERED RACING BUGGY

**4WD OFF-ROAD RACER**

# OPTIMA MID

- **FOUR-WHEEL DRIVE BY LIGHTWEIGHT EFFICIENT TIMING BELT.**
- **EXTRA-LONG WHEEL TRAVEL FOR TOP HANDLING.**
- **MID-SHIP MOTOR POSITION FOR BEST WEIGHT DISTRIBUTION.**
- **STRONG, LIGHT ALUMINUM-ALLOY PLATE CHASSIS.**
- **OVERSIZE PRESSURE SHOCKS, POWERFUL 240ST MOTOR, AND SPEED CONTROLLER INCLUDED IN KIT.**
- **GLASS-REINFORCED SUSPENSION ARMS FOR STRENGTH WITH LIGHT WEIGHT.**
- **LOW-PROFILE, HIGH-GRIP TIRES.**
- **HIGH PERFORMANCE: LIGHT WEIGHT, TOP SUSPENSION ACTION.**
- **EASY ASSEMBLY AND ADJUSTMENT. SIMPLE MAINTENANCE.**

**1:10 SCALE**

BATTERY : 7.2V-1200mAh

RADIO : 2ch.

[NOT INCLUDED]

BELT DRIVE  
**4WD**



**KYOSHO**  
THE FINEST RADIO CONTROL MODELS

KIT No. 3135

# OPTIMA MID

## BEFORE ASSEMBLY

\*Read the instruction carefully.

You can assemble the kit more easily if you have grasped the general idea of steps and structure beforehand by reading it through to the end.

\*Check the parts in the kit.

Check to see if all the parts are correctly bagged as they are listed in the "List of Bagged Parts". Your thorough understanding of the assembly will enable you to build the kit without any difficulty. Check the components in the kit prior to your startings of the assembly.

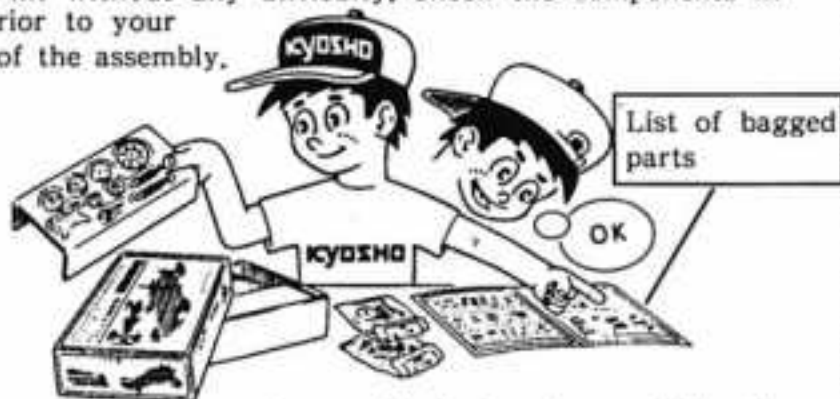

Any claims for replacements or refunds for the model in the process of assembly will not be accepted.

\*Learn the marks described in the instruction.

**SW CEMENT** Points where grease should applied. (It will reduce friction and assure smooth movements.)

**GREASE** Places to put some locktite. (It will prevent the screws and nuts get loosen by vibration while running.)

Steps where you particular attention is required.



\*Be well aware of the different types of screws.

1 The difference between the TP screw (short form of self-tapping screw) and the ordinary screw is....

Self Tapping Screw      Ordinary Screw

Coarser Thread!      Some of them Pointed tips.      Finer Thread!

2 The kinds of screws which will be used in this instruction.

Truss Screw      Set Screw  
Bind Screw      A hexagonal hollow in place of screw head.      Cap Screw  
Flat Head Screw      There are two kinds of thread, finer and coarser ones.

\*Pick up the correct parts and screw. Compare the shape and size of small parts, such as screws, nuts, and washers with the attached sheet of "List of Small Parts."

\*Be sure about the location and direction of parts to install.

Double-check the location and orientation of parts with the illustration before installation. When necessary, assemble the parts themselves tentatively before proceeding to the next step.

\*Do not tighten the self-tapping screw too tight.

Do not use excessive force when tightening the self-tapping screws, or you may strip the thread in the plastic. It is recommended to stop tightening it when the thread part on the screw goes into the plastic part and you feel some resistance from the tightening.

Good      Over tighten may strip the thread in the plastic.



\*Things need besides the kit.

(2 Channel Radio System)  
Two types of radio control set are on the market, the stick type and the steering wheel type. Choose which ever you like.

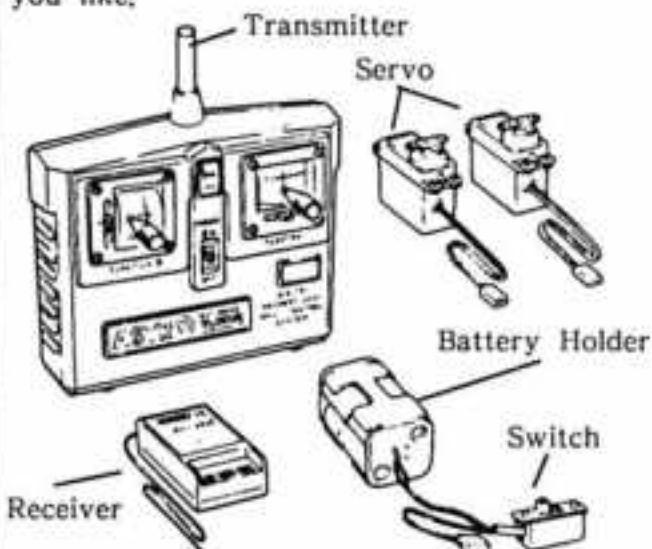

(Battery for radio System)

AA Size Battery  
For Transmitter      .... 8 pcs  
For receiver      .... 4 pcs.

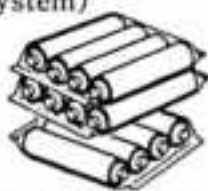

(Ni-Cd Battery)

"Optima Mid" is designed to use a rechargeable 7.2V Ni-Cd Battery pack. 7.2V Racing Battery and 7.2V Power Battery are ideal for the purpose.

No.2306 7.2V Power Battery



No.2218 7.2V Racing Battery



(Charger for Ni-Cd Battery)

The Kyosho's Ni-Cd battery is of high performance. If it is charged correctly, it will operate for a considerable period of time.

Use one of the Chargers listed below which suits your need.

Model	Name	Time	Rate %	Features
No.2326	7.2V Power Quick Charger (DC12V)	15 (Min)	70 %	For beginners Built-in timer
No.1845	Lambda Quick Charger (DC12V)	20 (Min)	100 %	Trickle charging auto-cut off at peak charge.

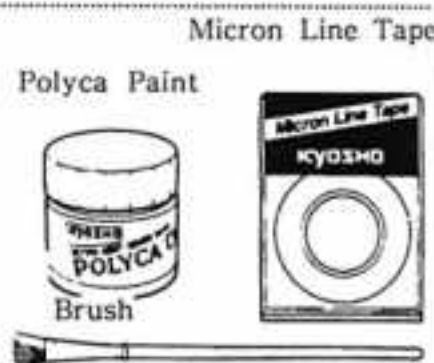
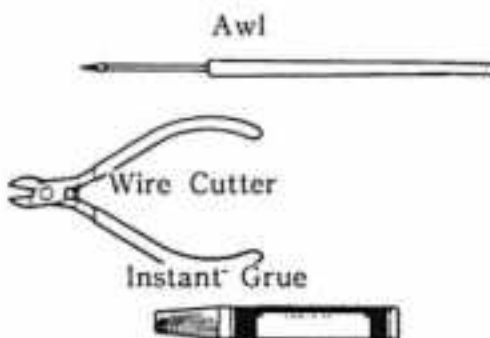
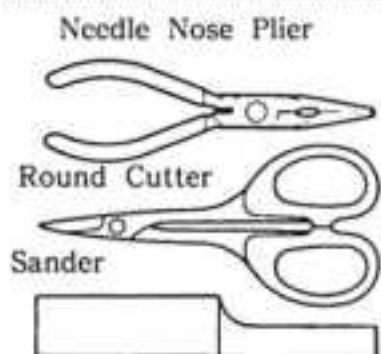
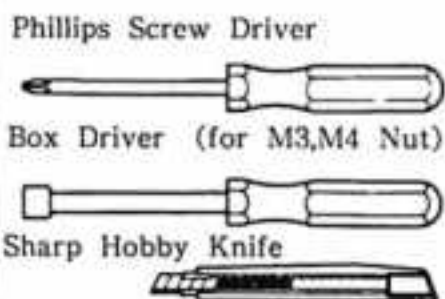

# 1 INSTALLATION OF JOINT



See page 20 for an exploded view of the differential gear.



Keep the header by putting it in the bag or taping it down.

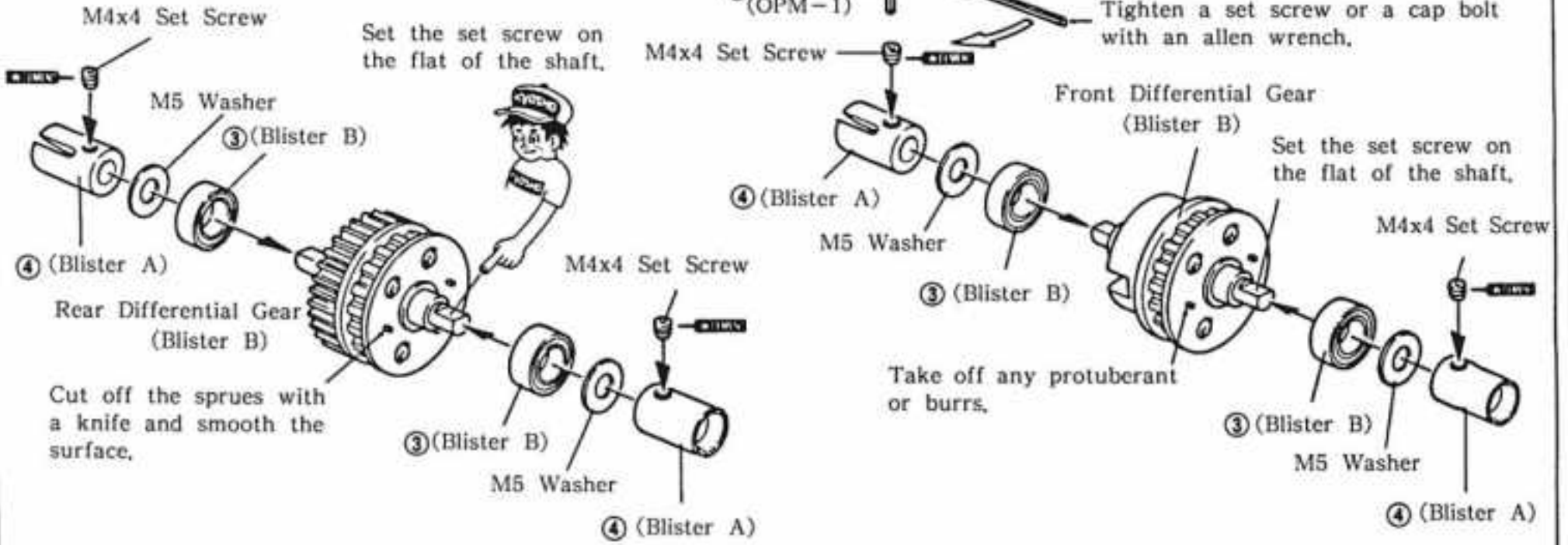

# 2 ASSEMBLY OF REAR GEAR BOX

## Step 1

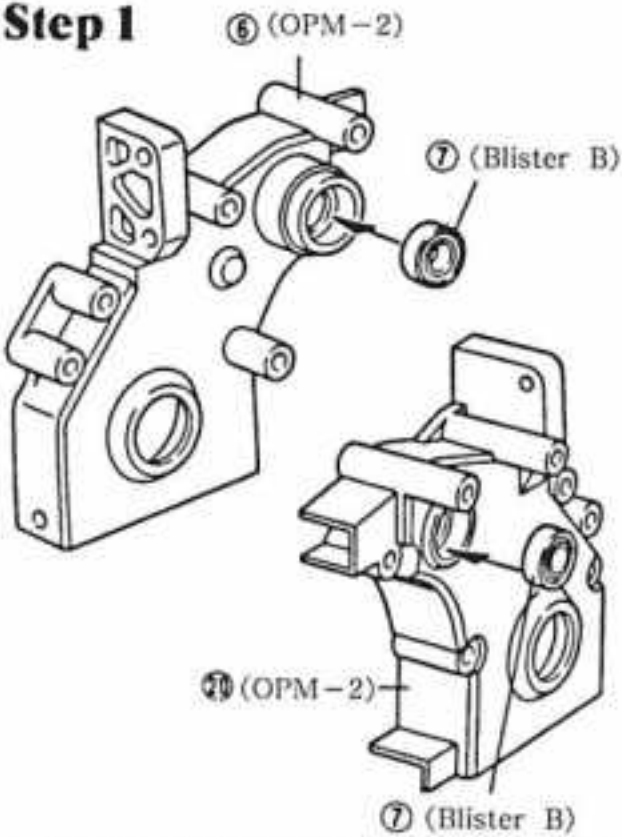

## Step 2

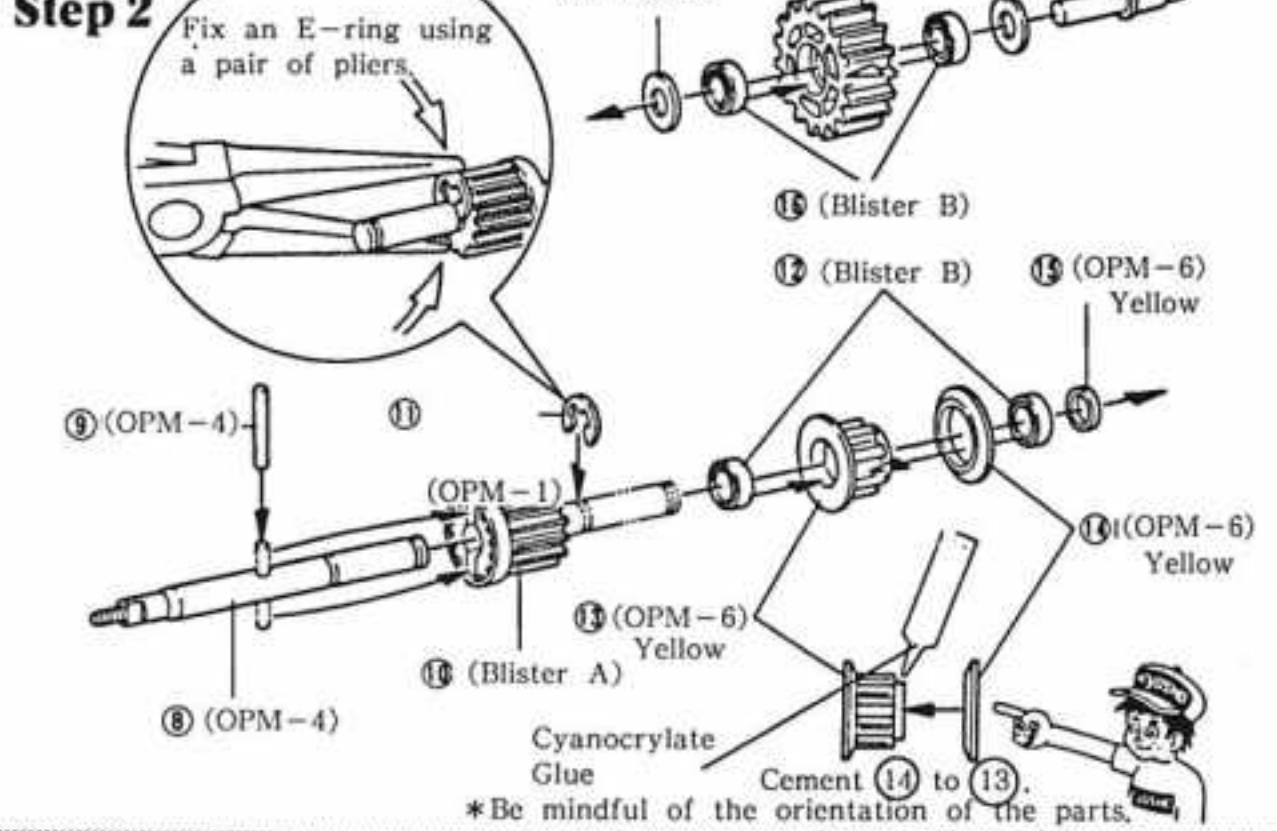

## Step 3

After assembling the parts in order from ① to ③ steps, put on ⑱ as illustrated below, and fasten ⑳ with bolts in the position.

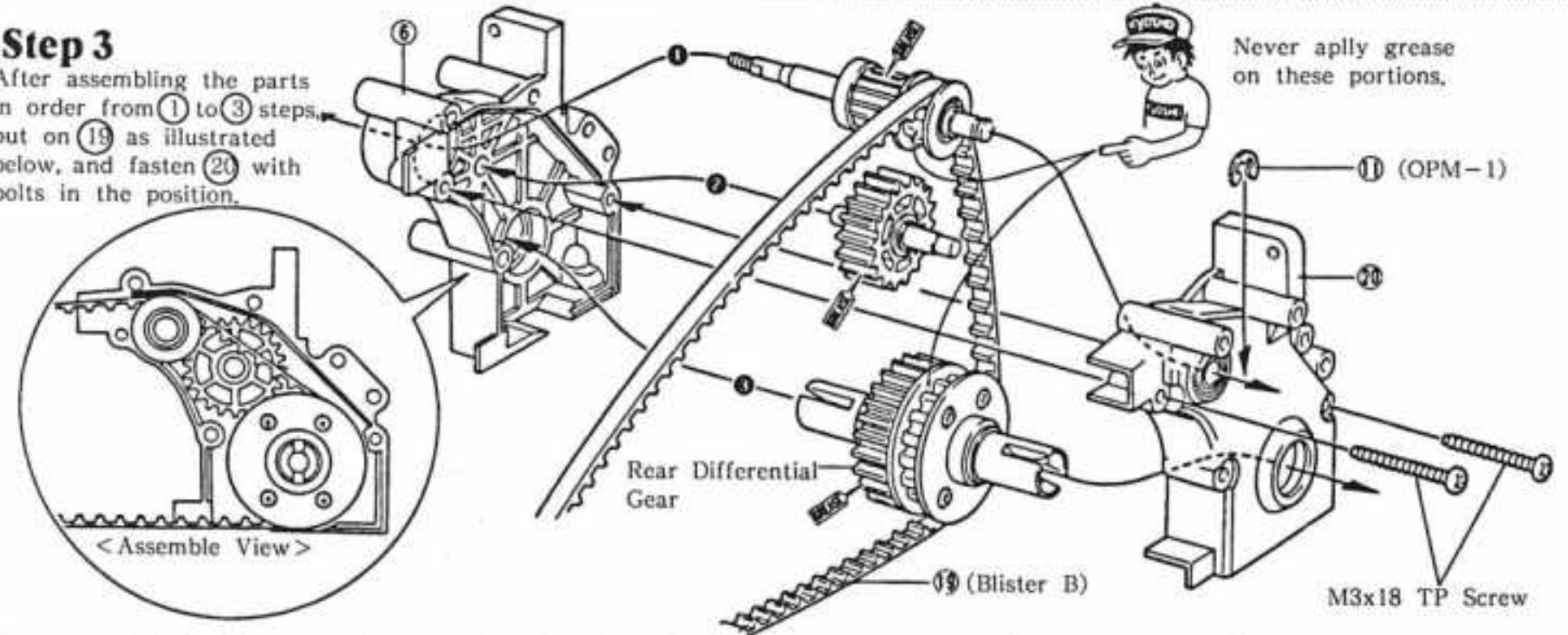



## 6 ASSEMBLY OF FRONT GEAR BOX

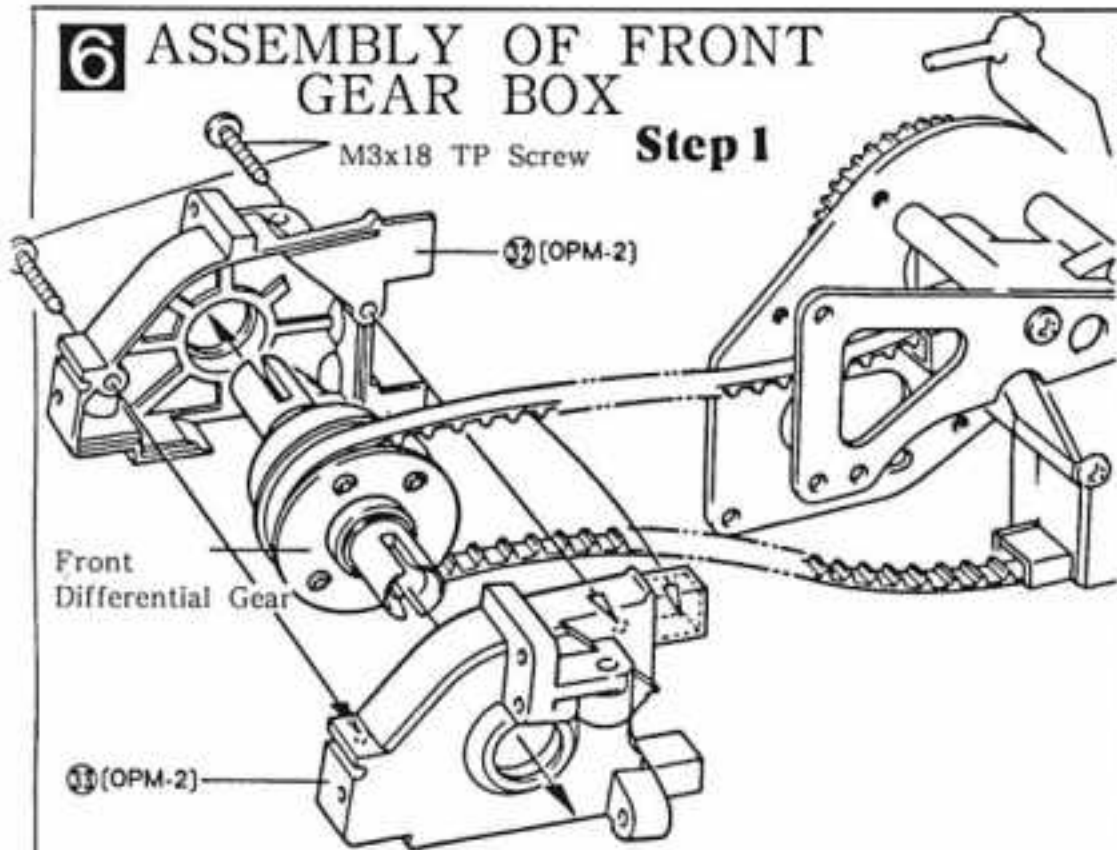

### Step 2

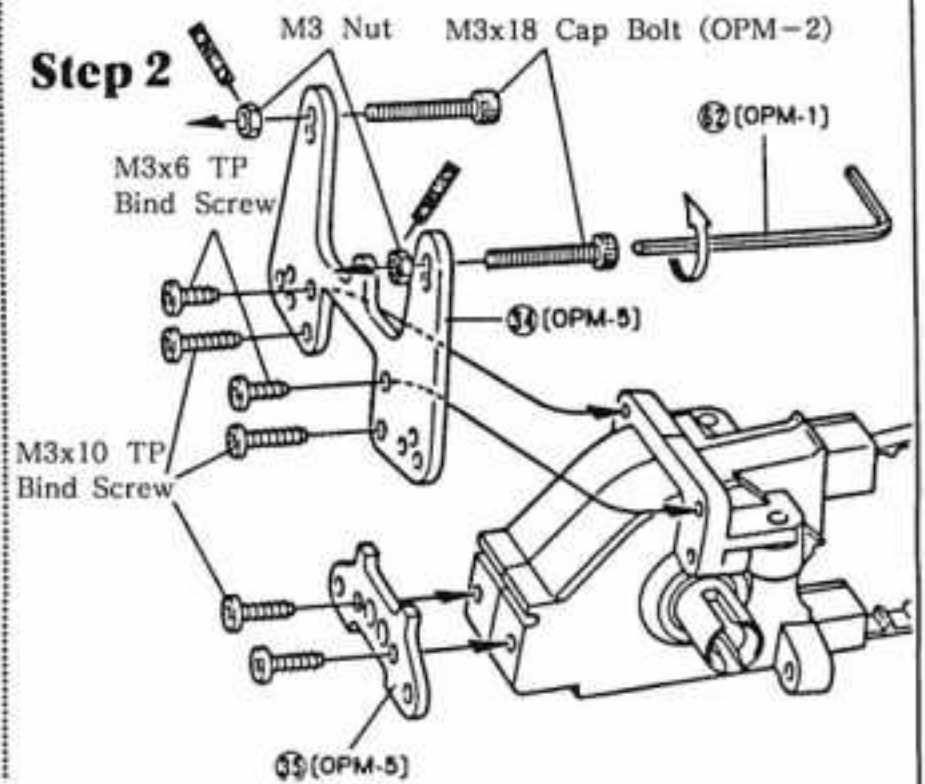

## 7 INSTALLATION OF GEAR BOX

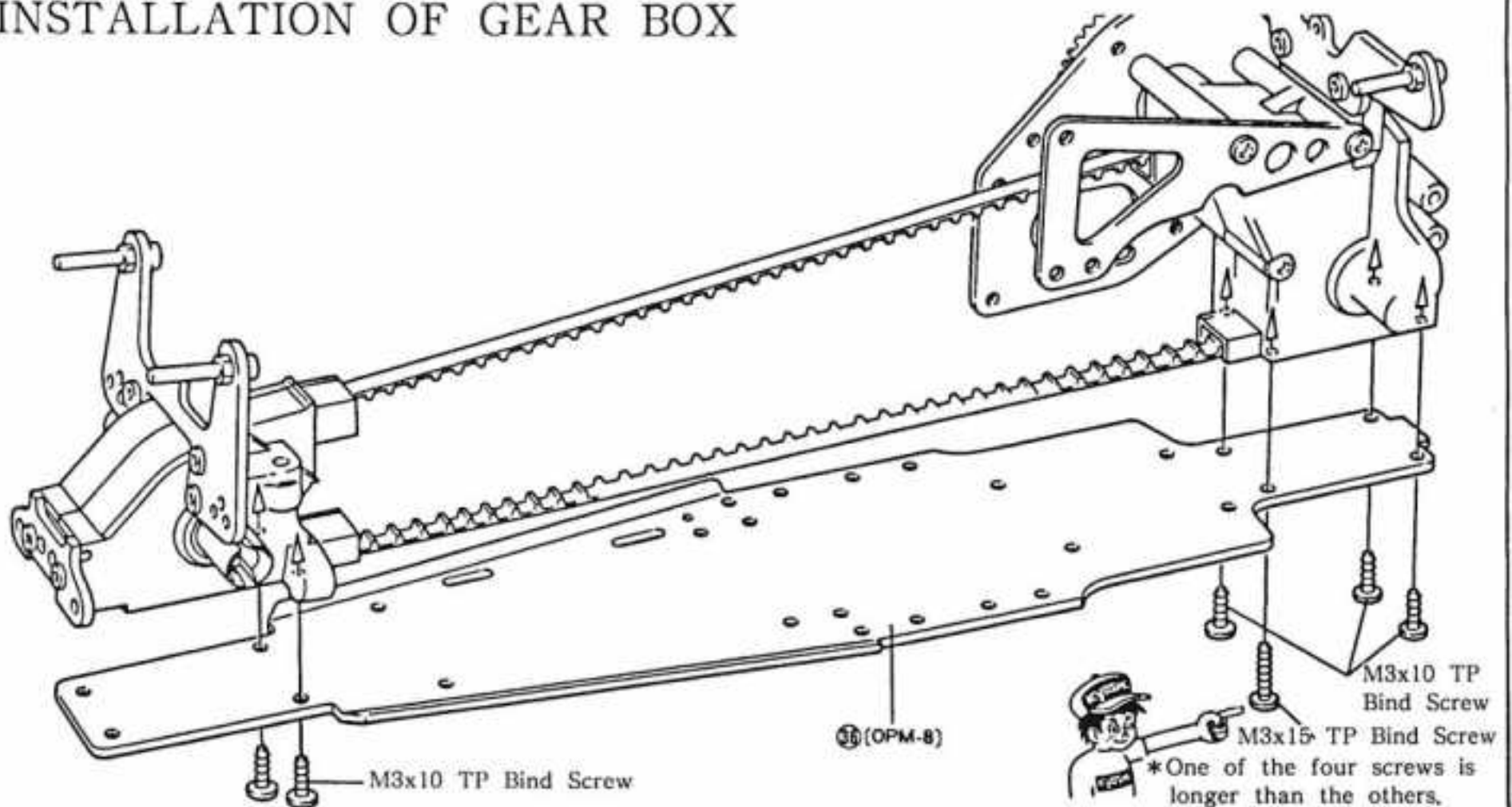

## 8 INSTALLATION OF BELT COVER (A)

After cutting out this part, clean the surface, particularly make it free from oily stain, where 39 is to be cemented.

### Step 1

Cut off the end along the cut line.

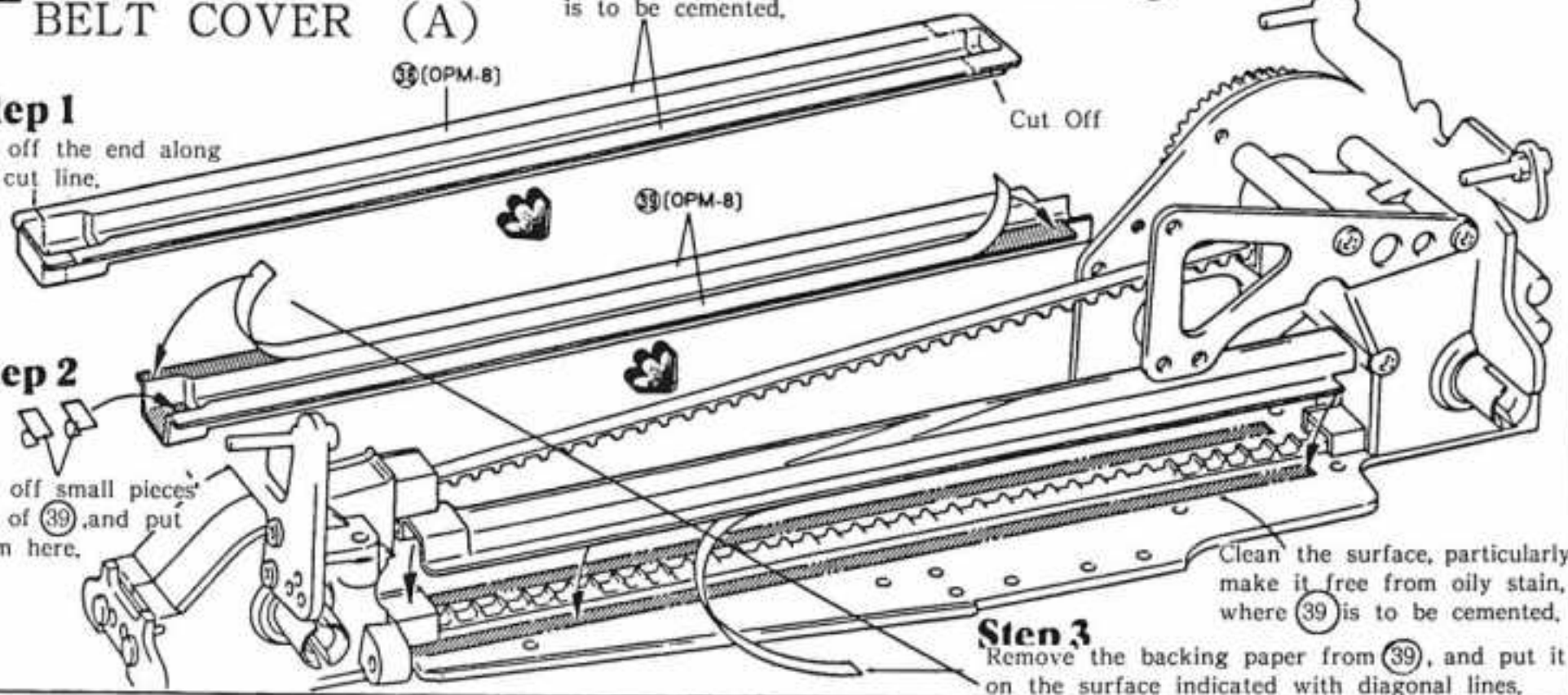

### Step 2

Cut off small pieces out of 39, and put them here.

Clean the surface, particularly make it free from oily stain, where 39 is to be cemented.

### Step 3

Remove the backing paper from 39, and put it on the surface indicated with diagonal lines.

# 9 INSTALLATION OF UPPER DECK MOUNT

Screw locking compound prevents dusts from entering through the belt cover and the chassis.

\*Apply it on the shaded area on both sides.

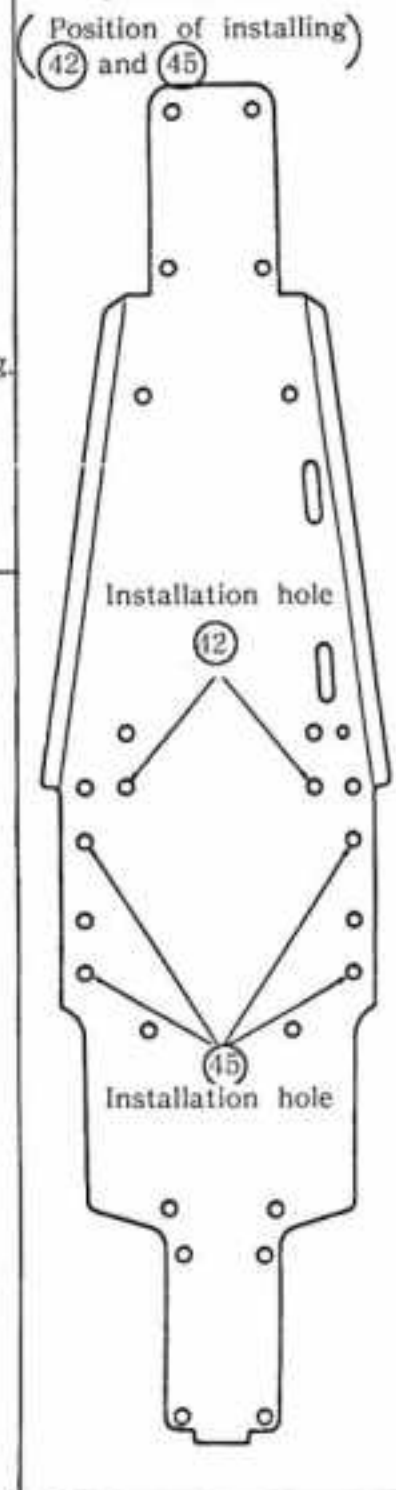
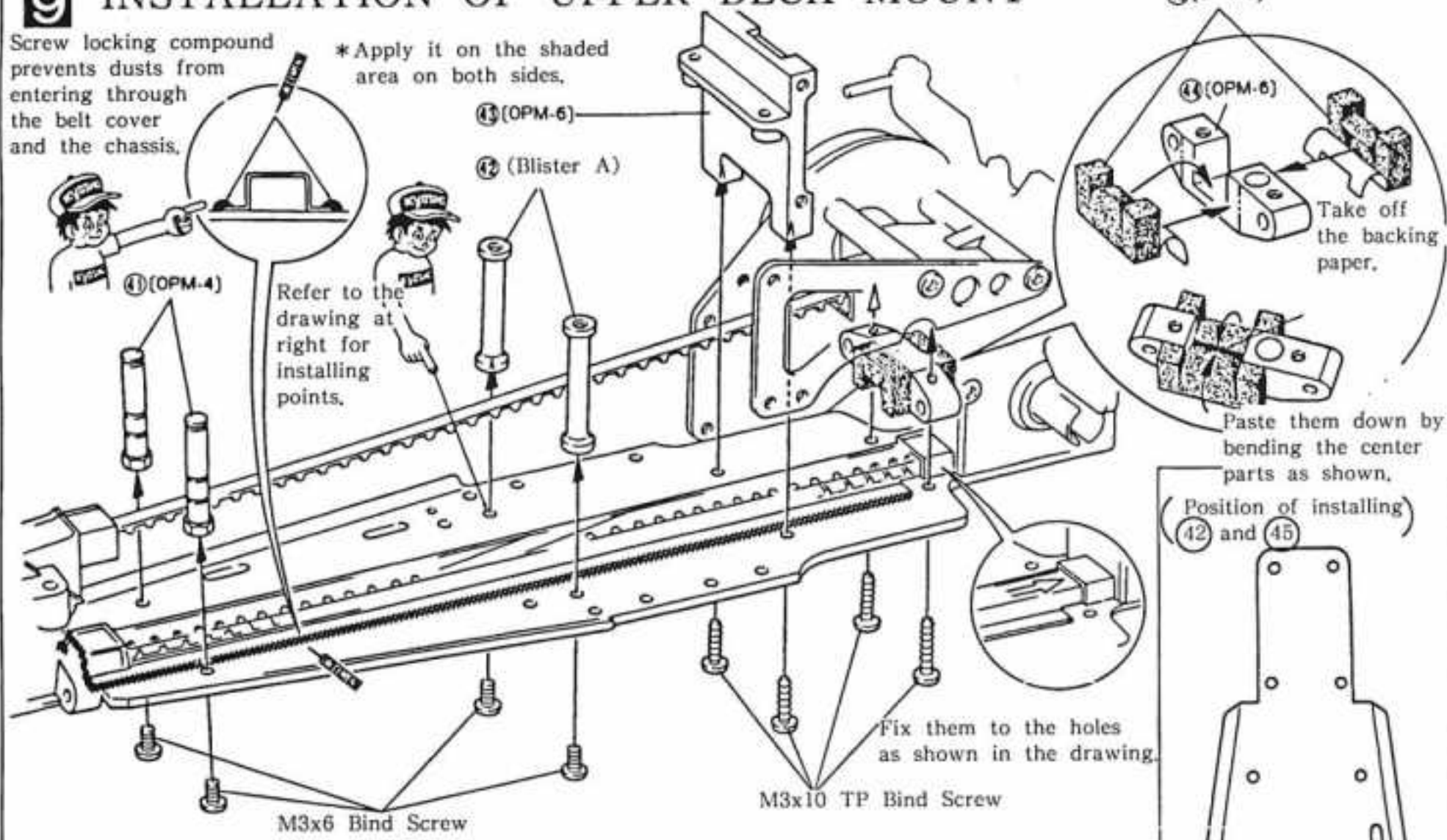

# 10 INSTALLATION OF BATTERY HOLDER

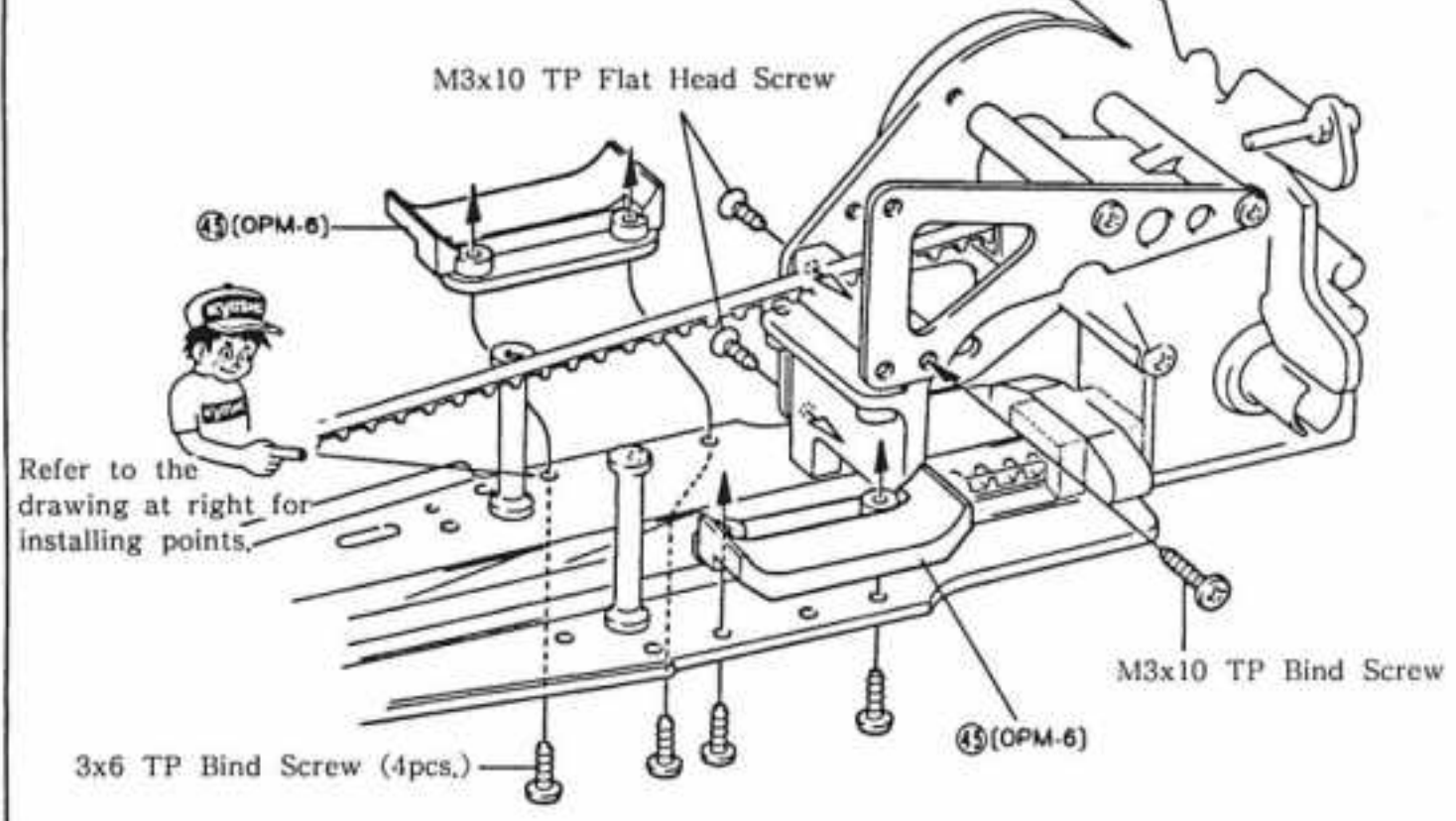

# 11 ASSEMBLY OF KNUCKLE ARM

## Step 1

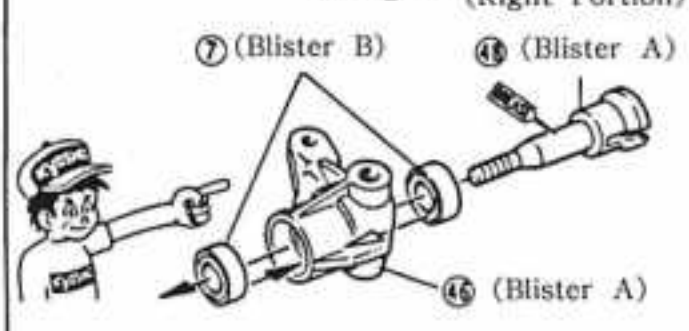

## Step 2

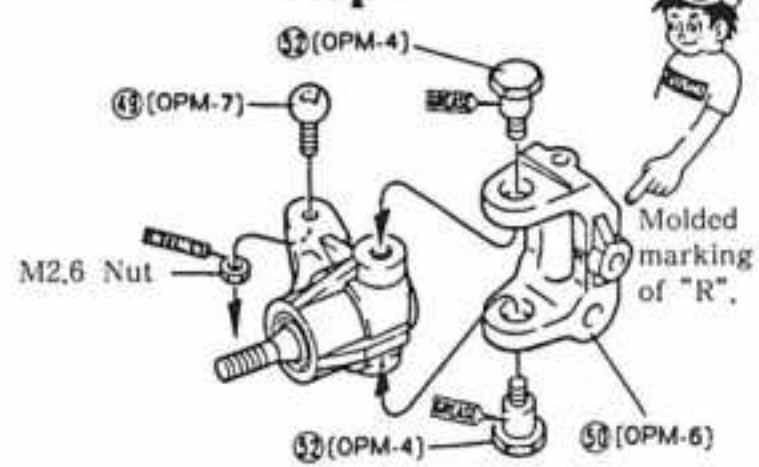

## Step 3

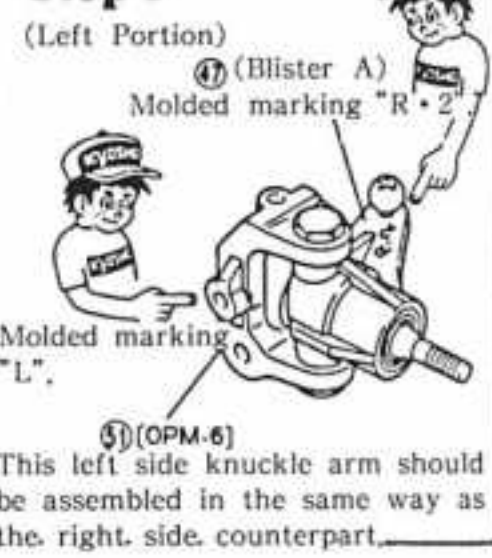

\*Be careful about the marking and the orientation of the parts.

## 12 INSTALLATION OF FRONT SUSPENSION ARM

You need this part when you install the optional stabilizer.

### Step 1

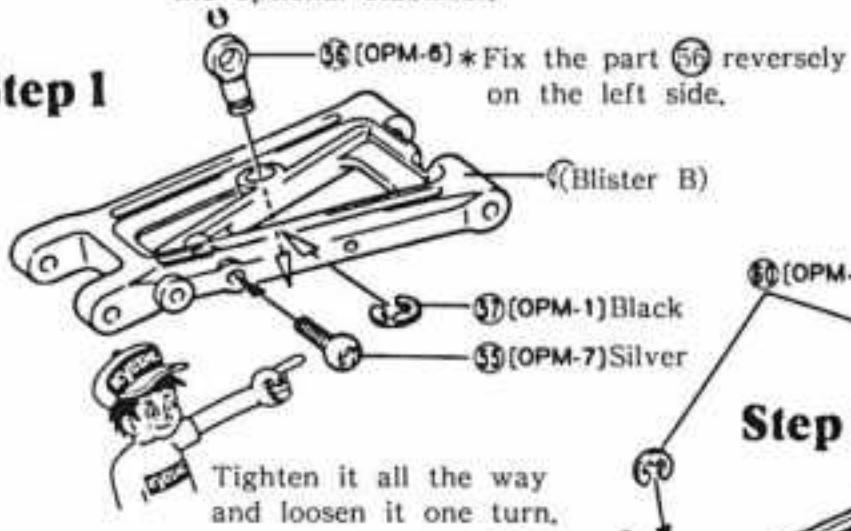

(Right Portion)

Tighten it all the way and loosen it one turn.

### Step 2

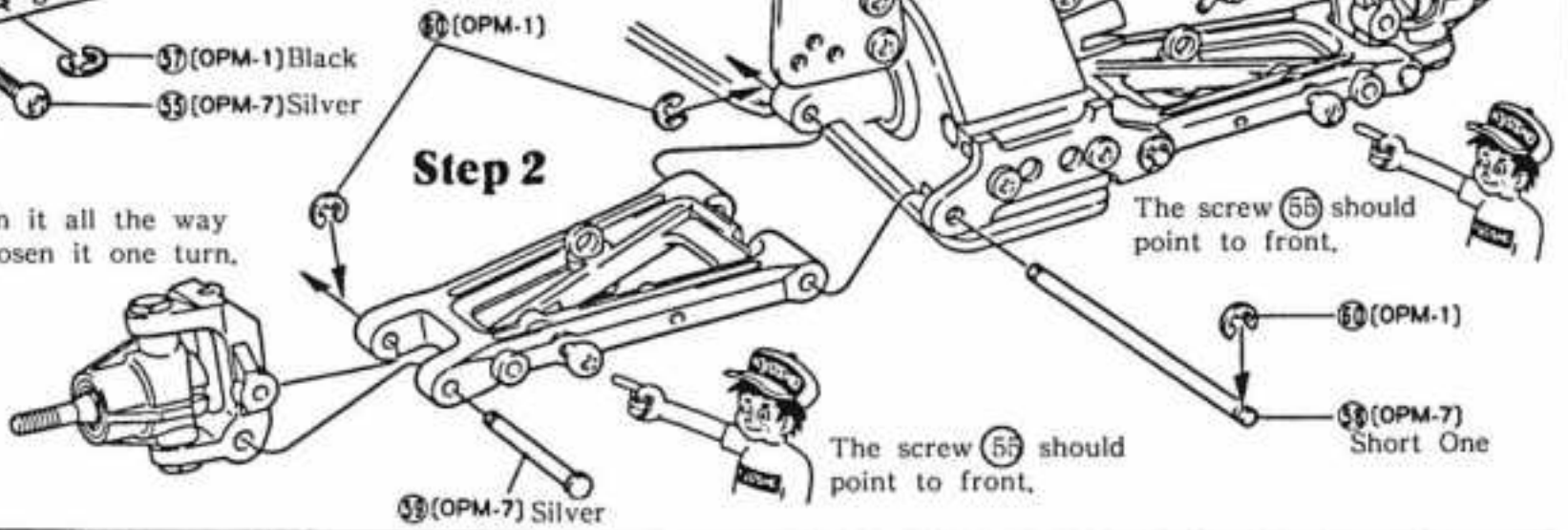

(Left Portion)

The part (56) should come upward

The screw (55) should point to front.

The screw (57) should point to front.

(OPM-1)  
Short One

## 13 INSTALLATION OF FRONT UPPER ROD

### Step 1

Assemble two pieces of the upper rod.

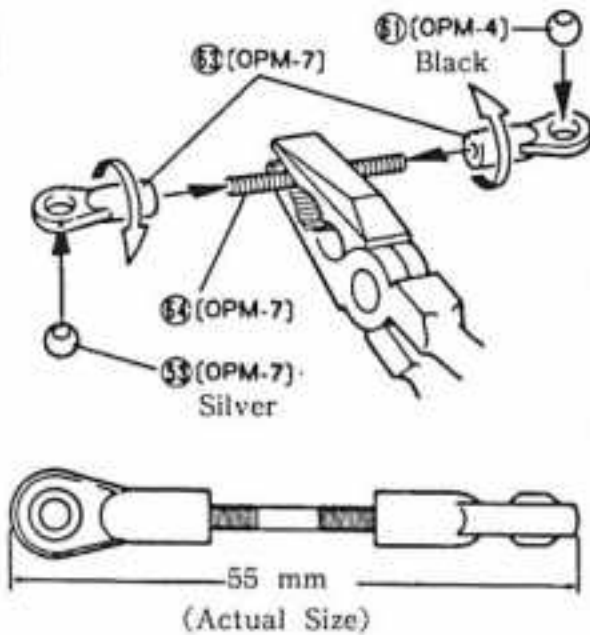

### Step 2

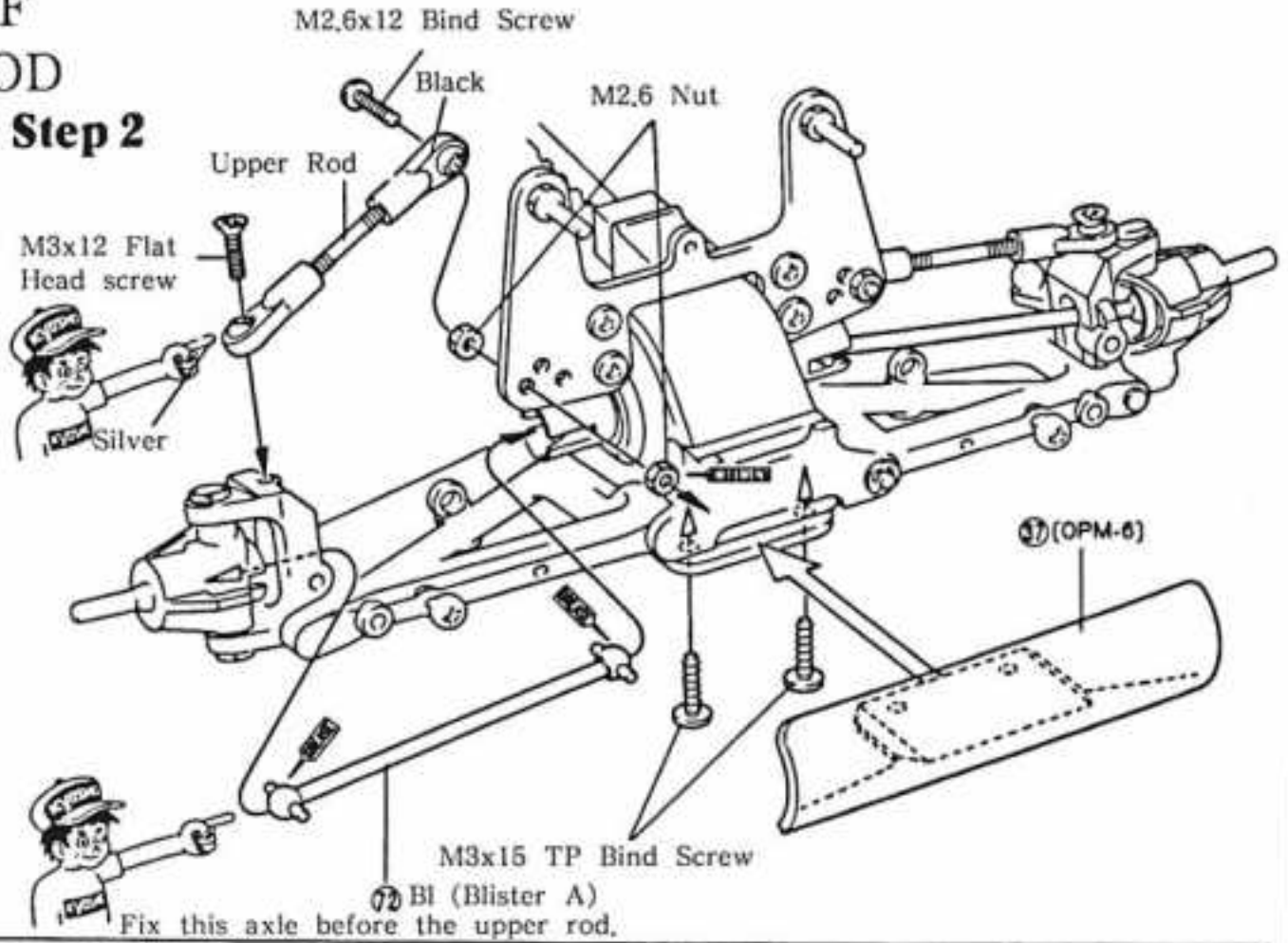

M2.6x12 Bind Screw

Black

M2.6 Nut

Upper Rod

M3x12 Flat Head screw

Silver

M3x15 TP Bind Screw

(Blister A)

Fix this axle before the upper rod.

## 14 INSTALLATION OF REAR HUB

### Step 1

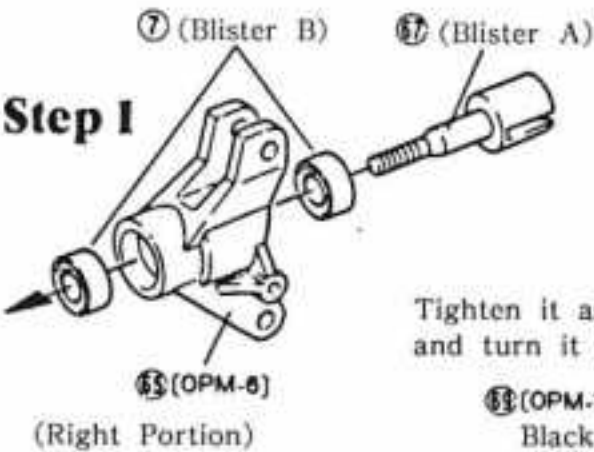

(Right Portion)

### Step 2

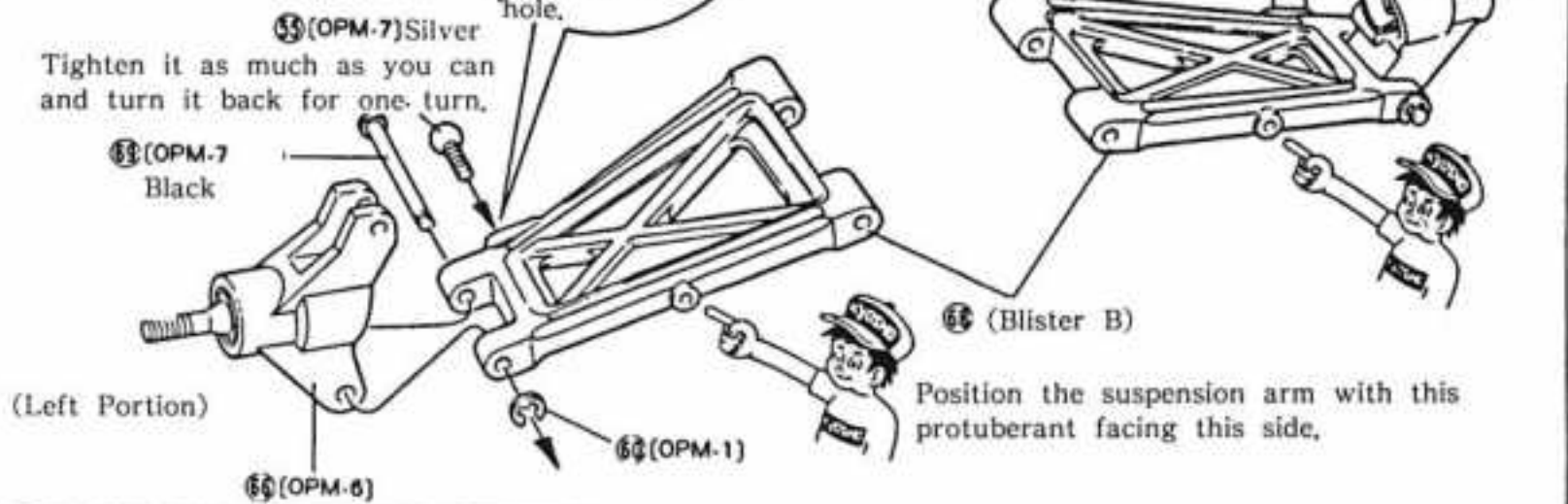

(Left Portion)

Fix the screw into the most outer hole.

Tighten it as much as you can and turn it back for one turn.

(Right Portion)

(Blister B)

Position the suspension arm with this protuberant facing this side,

# 15 INSTALLATION OF REAR SUSPENSION ARM

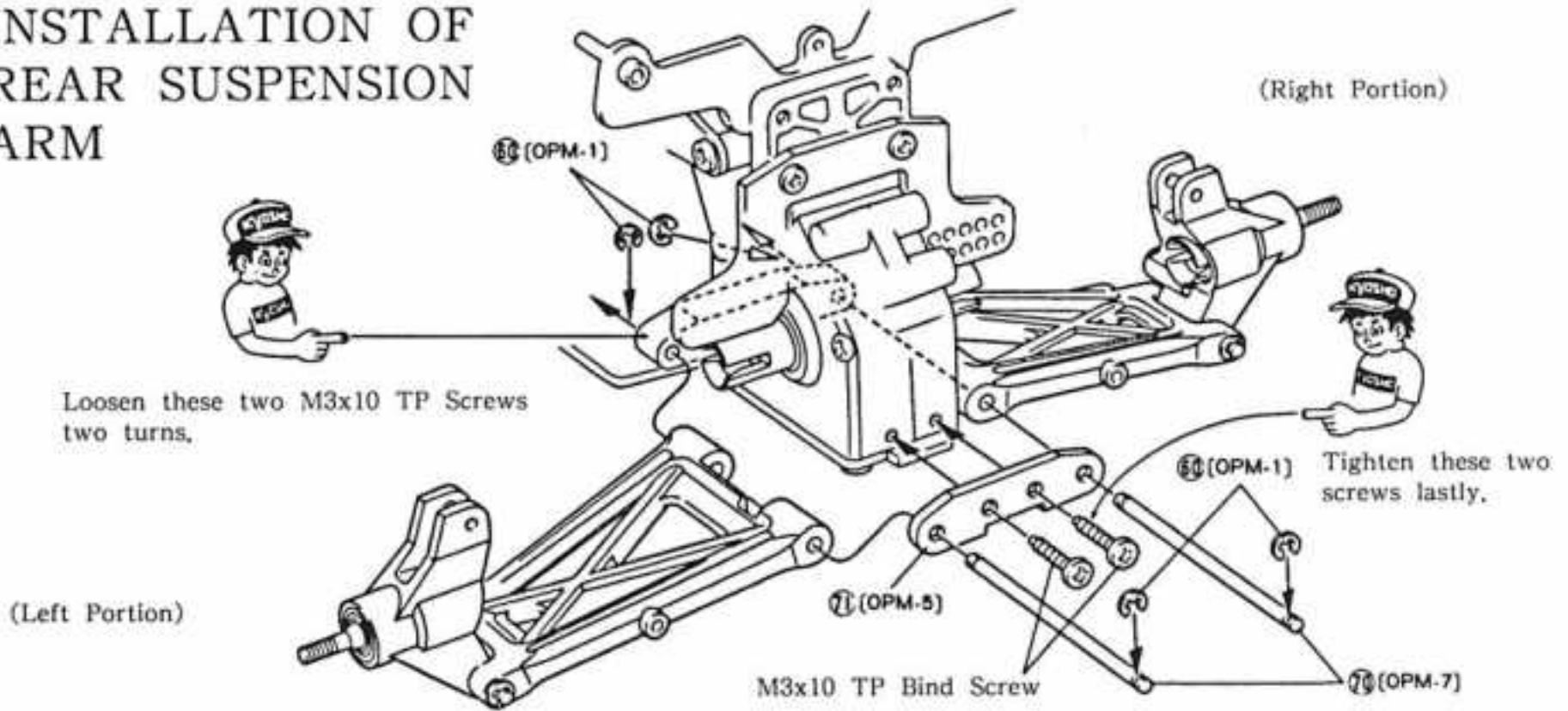

# 16 INSTALLATION OF REAR UPPER ROD

Assemble two pieces of the upper rod.

## Step 1

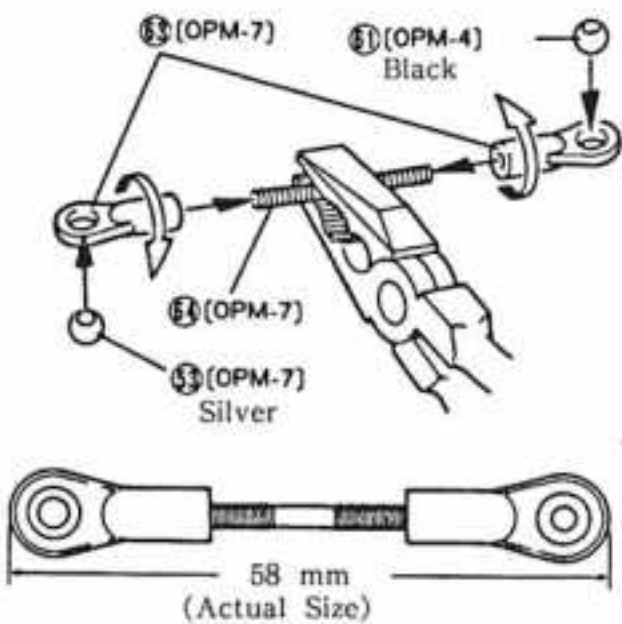

## Step 2

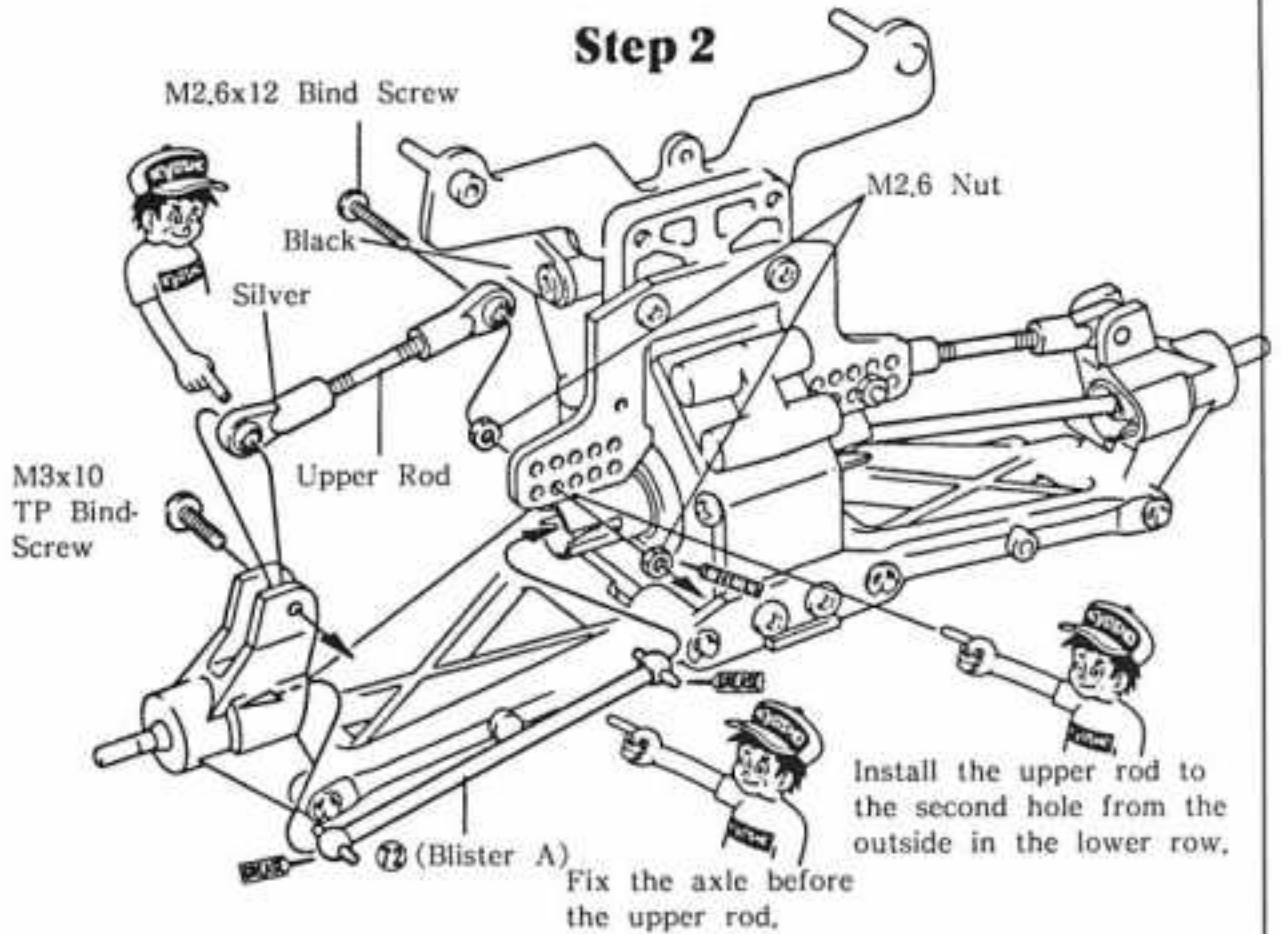

# 17 ASSEMBLY OF SERVO SAVER

## Step 1

(Tighten the ball end.)

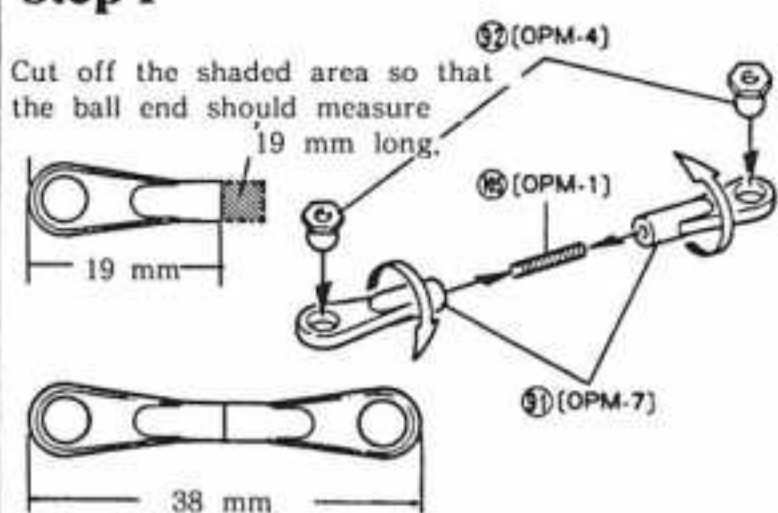

## Step 2

Cut away the unnecessary part with a pair of clikes.

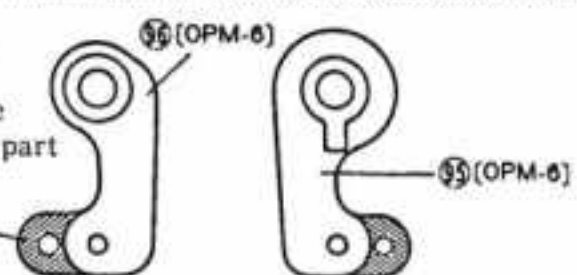

## Step 3

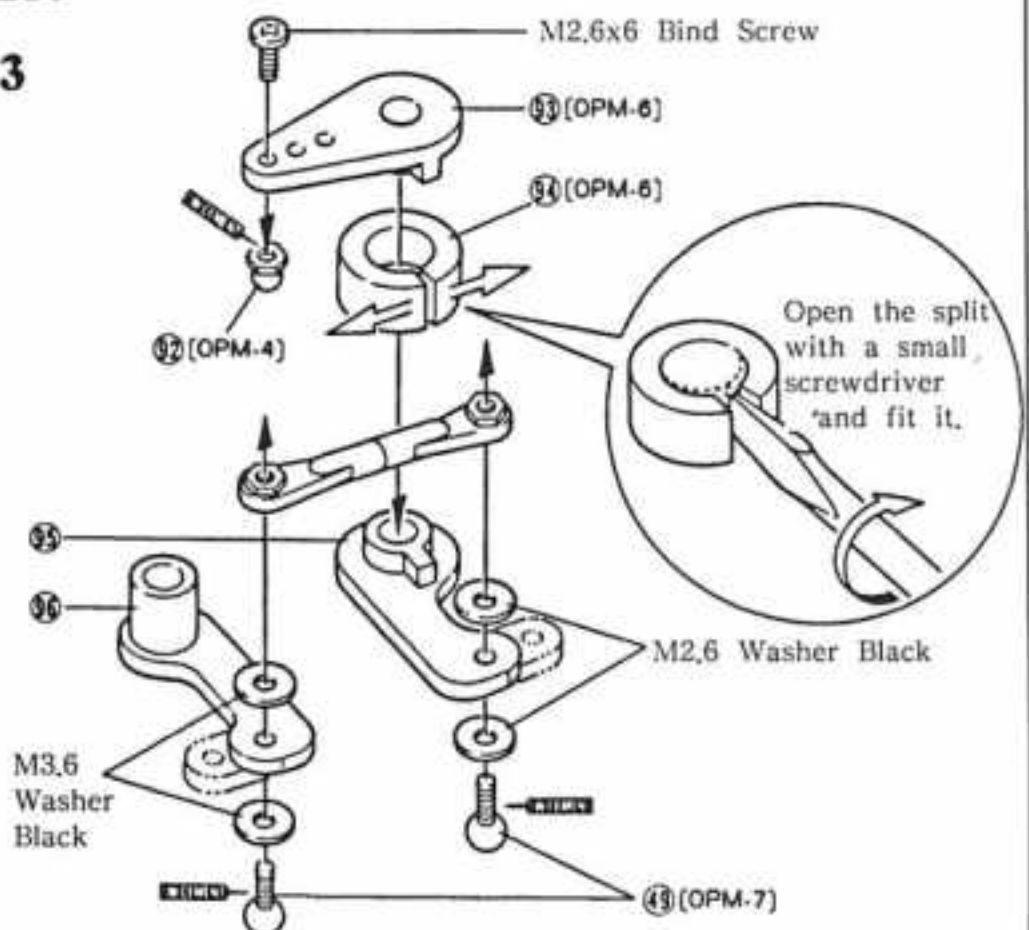

# INSTALLATION OF SERVO SAVER

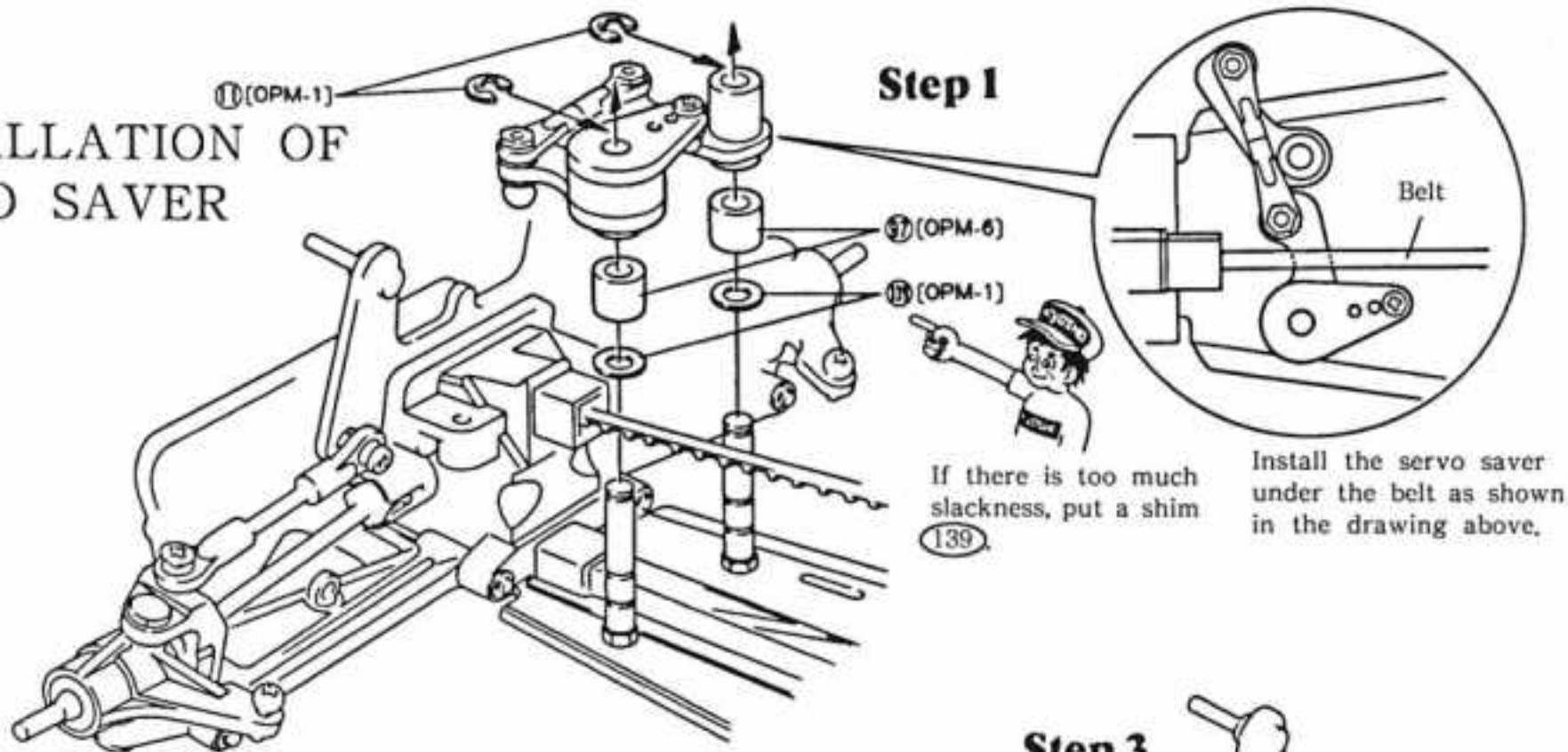

## Step 2

Assembly of tie rod.

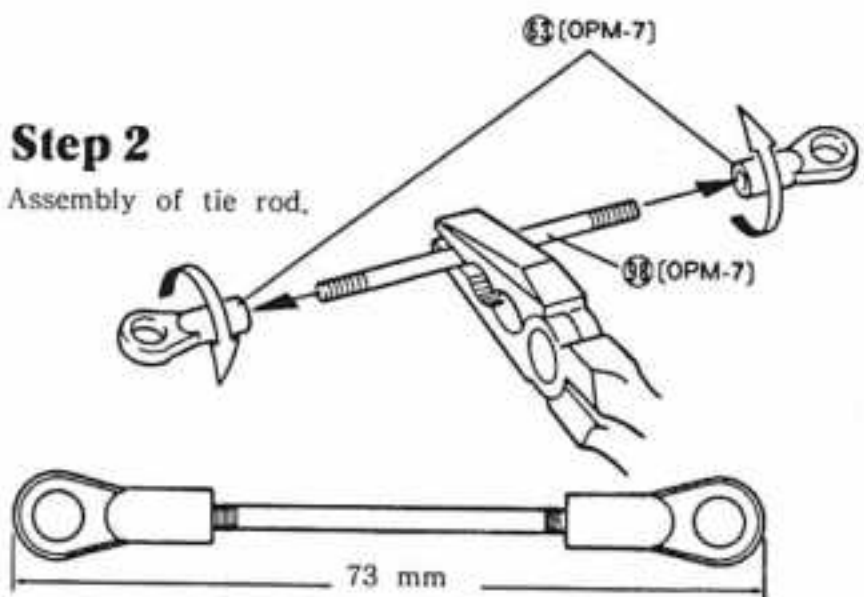

## Step 3

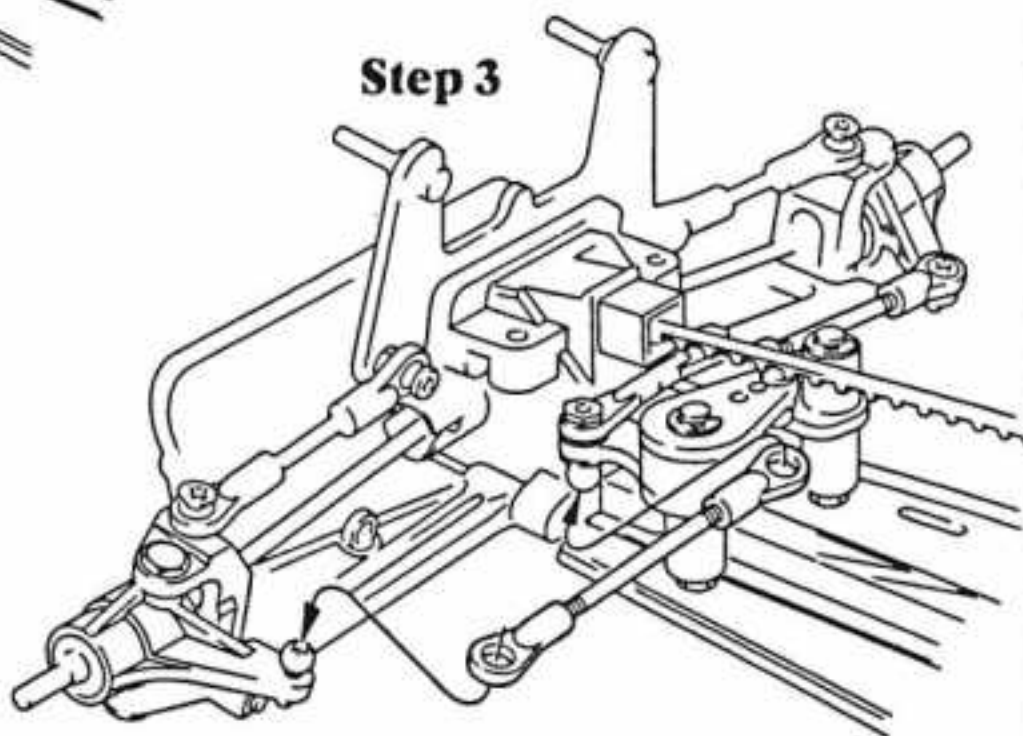

# 19 ASSEMBLY OF OIL SHOCK

Rear Shock Piston

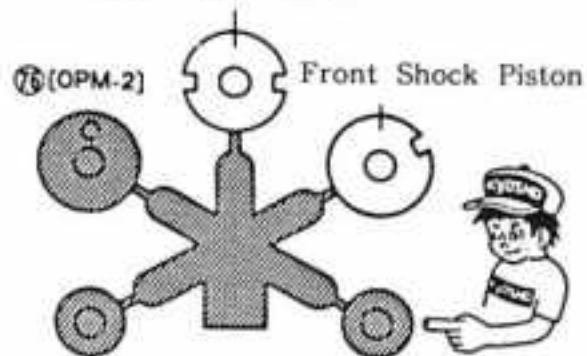

Cut away the shaded area, they will not be used.

Cut off the remaining of sprue runners carefully.



\*The parts marked with ★ will be used for the front and rear commonly.

Assemble the parts in order from ① to ⑥.

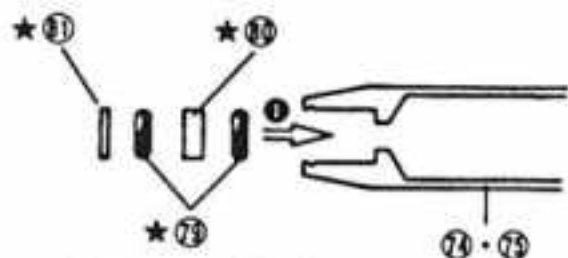

Put on an C-ring. (Be careful not to lose it.)

Fit into the groove.



Fix the piston with an E-ring.

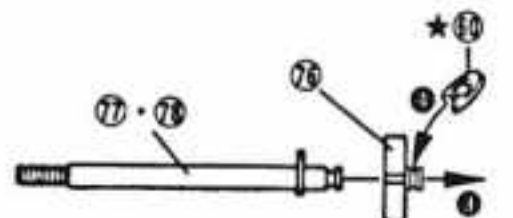

Put the shaft through the shock case and screw in the shock end.

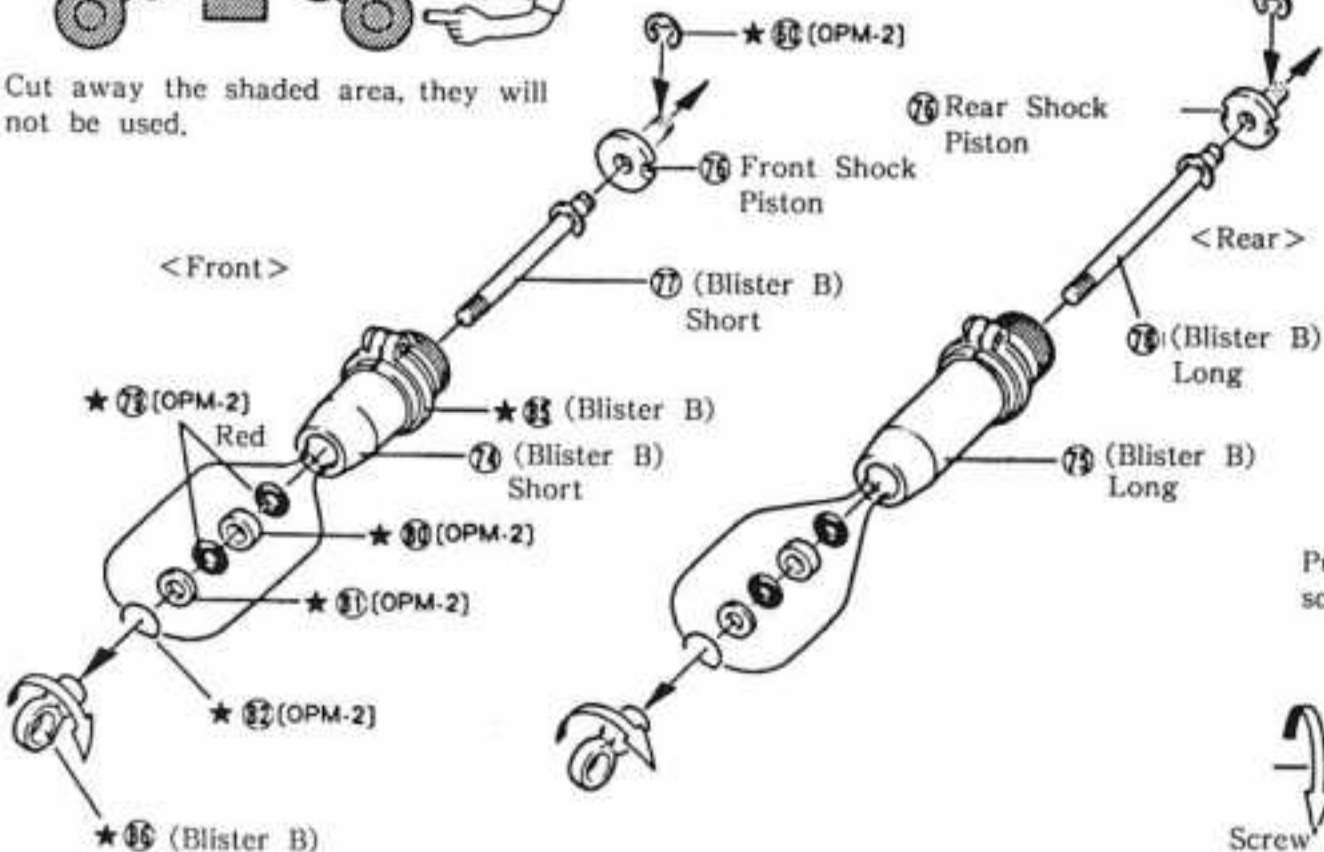
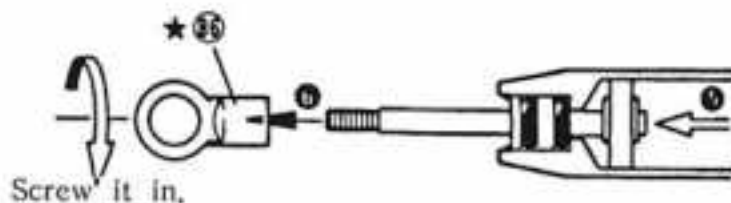

## 20 FILLING THE SHOCK OIL

### Step 1

Pull down the piston to the bottom and pour oil slowly. Then move the piston up and down gently to get rid of air bubbles.

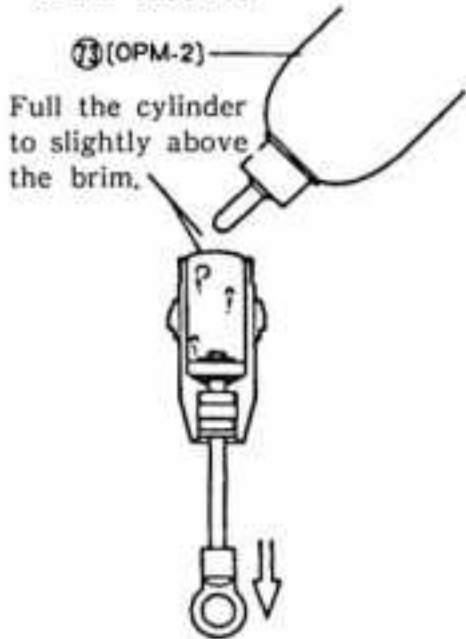

### Step 2

Keep the piston in the lowest position and tighten (83) gradually, then excessive oil will run over.

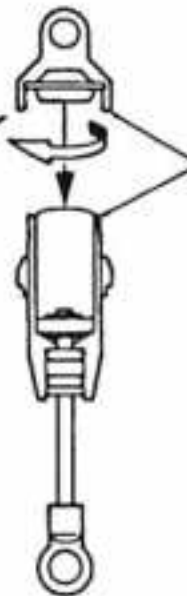
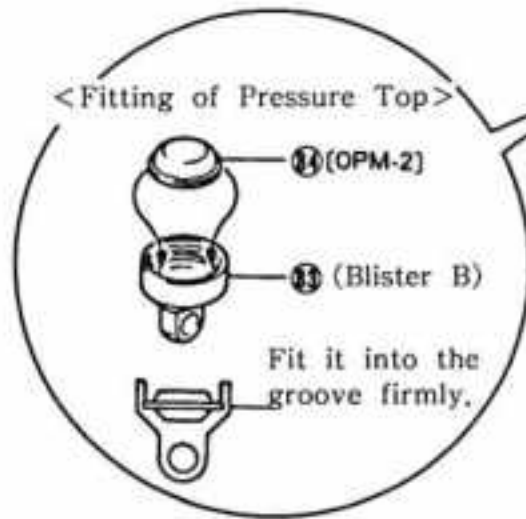

In the end, tighten it firmly so that the oil will not leak out.

### Step 3

Confirm that it will work smoothly by moving the piston up and down.

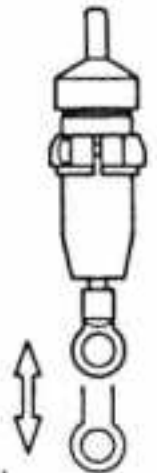

It should move without any binding.

## 21 INSTALLATION OF SHOCK SPRING

### Step 1

Put the spring over it.

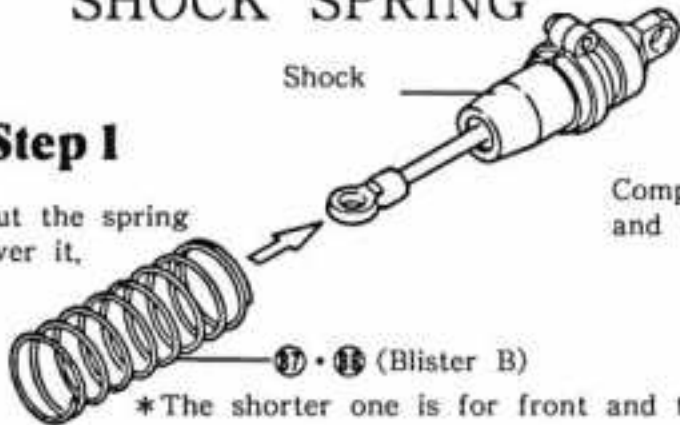

### Step 2

Compress the spring and fix the (89).

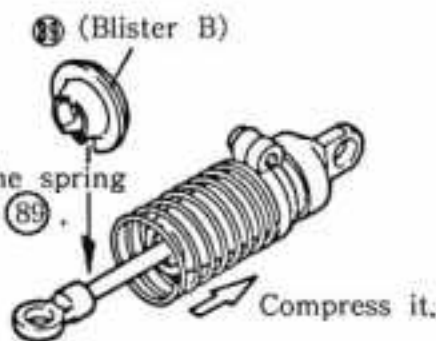

• Front Shock Short

• Rear Shock Long

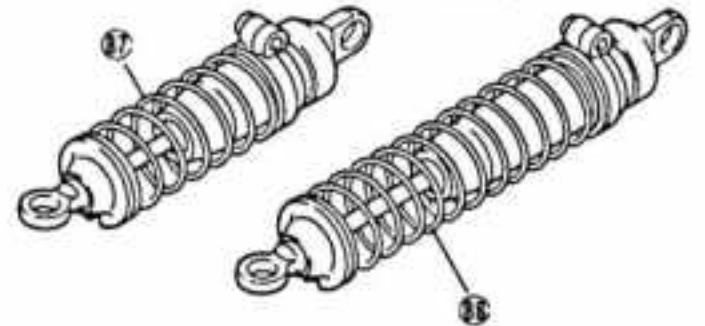

## 22 INSTALLATION OF SHOCK

<Front>

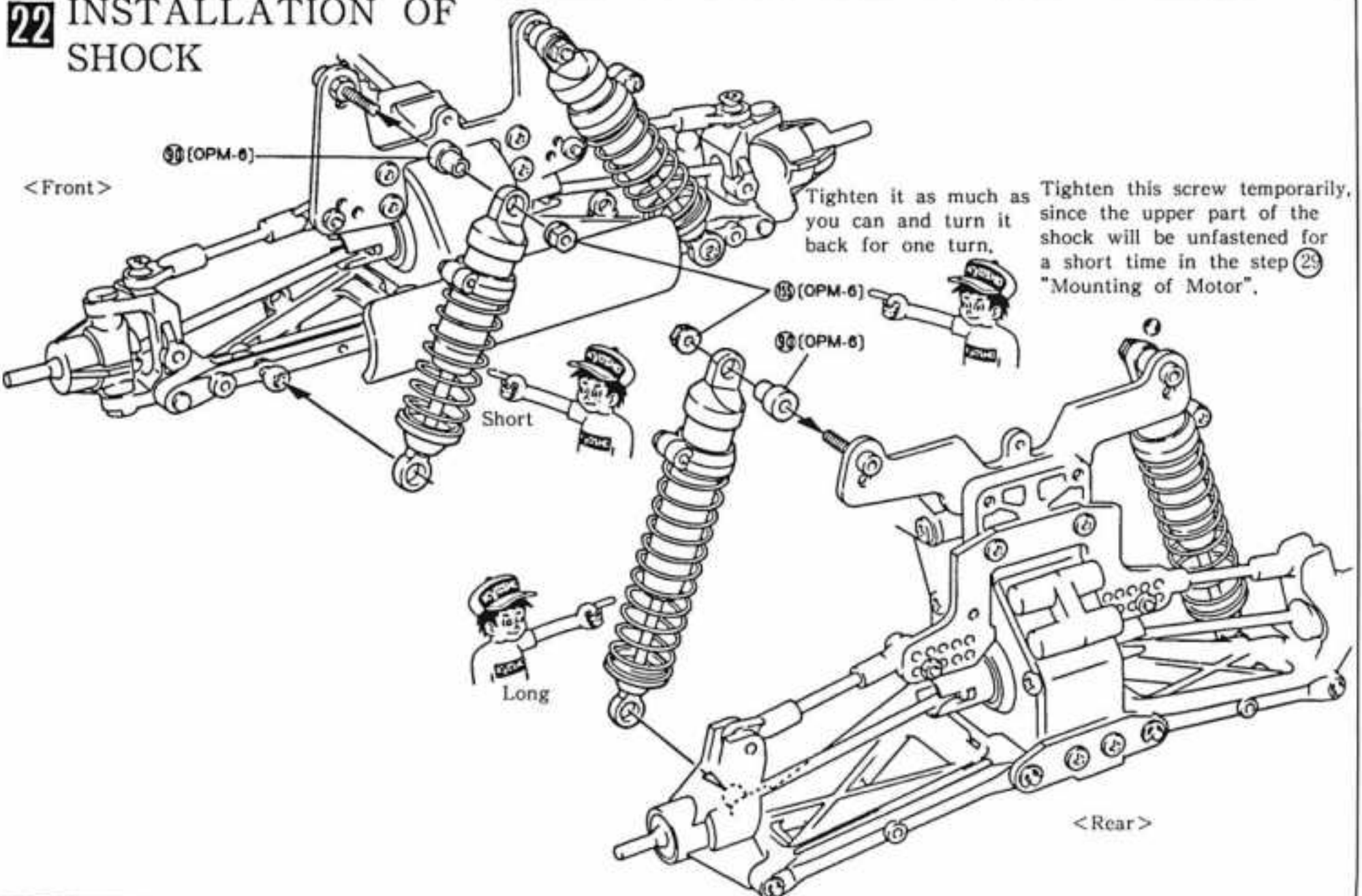

## 23 HOW TO CHECK RADIO SYSTEM

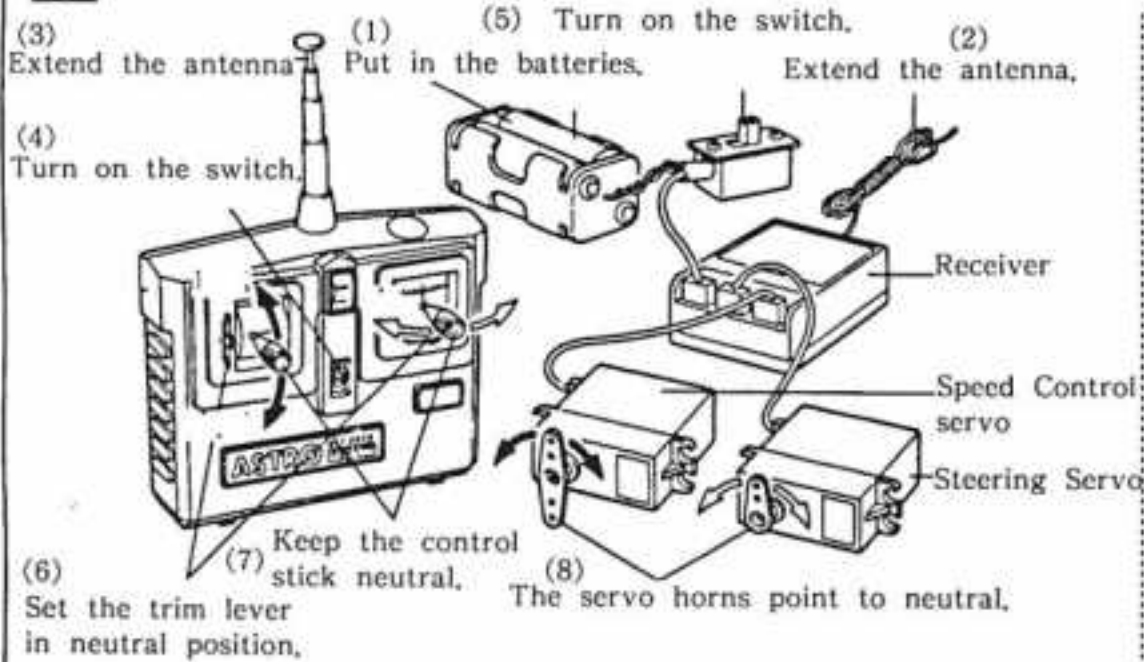

- transmitter..... It is in effect a control box. Signal waves are transmitted through an antenna according to the stick movements.
- Receiver..... Receives the signals from the transmitter and send them to the servos.
- Servo..... They really move the control mechanism of a model car in accordance with the signals from the receiver.
- Antenna..... An antenna on the transmitter sends signals, and one on the receiver accepts them. They should be fully extended.
- Trim Lever..... They will adjust the neutral position of servos, thus regulate the steering and advancing controls finely.
- Battery..... You can tell the amount of electricity in a battery and how the signals are emitted.
- Meter
- Servo..... They are intermediate devices on the servos to activate the controls. There are several types in shape. They should be selected depending upon the usage.
- Horns



When switch on the radio.....

Get the switches in order from transmitter to receiver.

When switch off the radio.....

In order from receiver to transmitter.

\*Operate the radio units in numerical order.

A two channel radio is composed of things like a transmitter, receiver, servos, and battery case.

## 24 ASSEMBLY OF STEERING ROD

### Step 1 (Cut Off Shaded Part)

Enlarge the hole with an awl so that you can put the control easily.

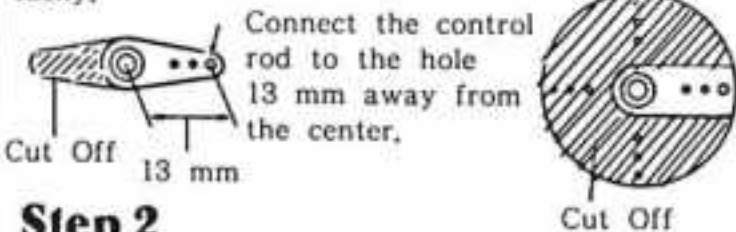

### Step 2

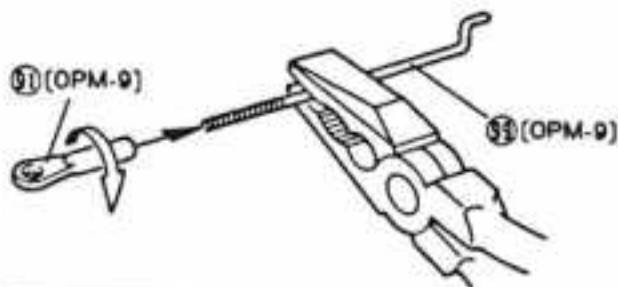

### Step 3

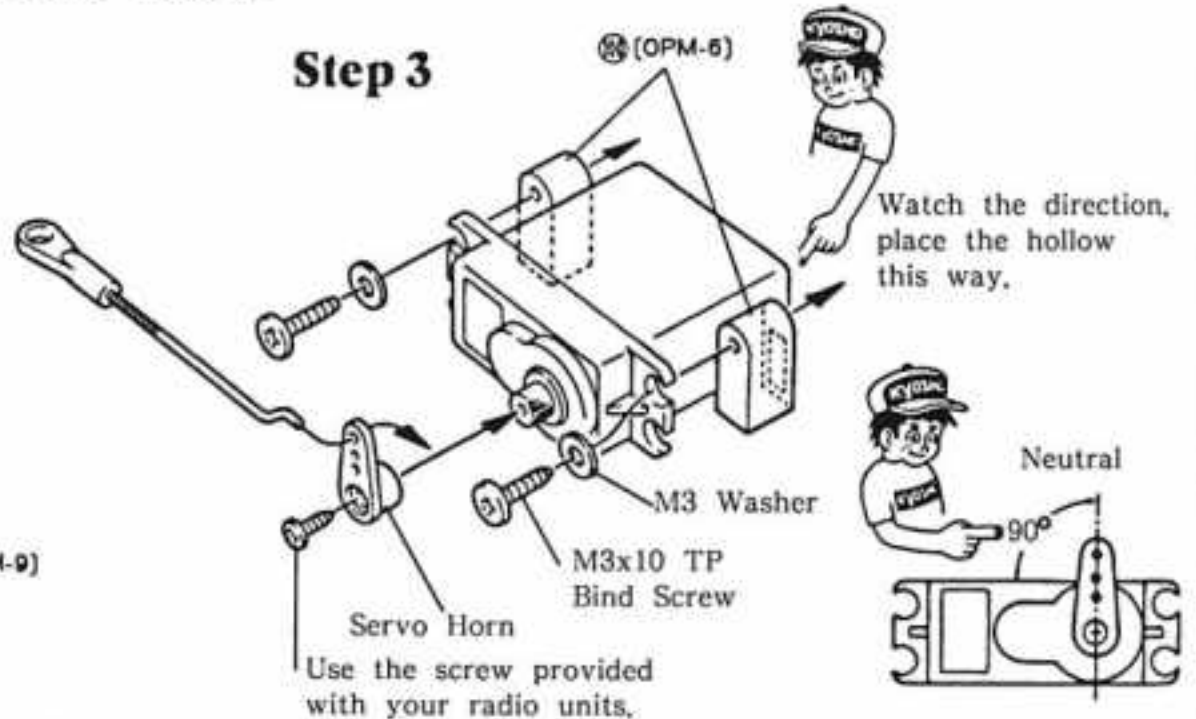

## 25 INSTALLATION OF STEERING TIE ROD

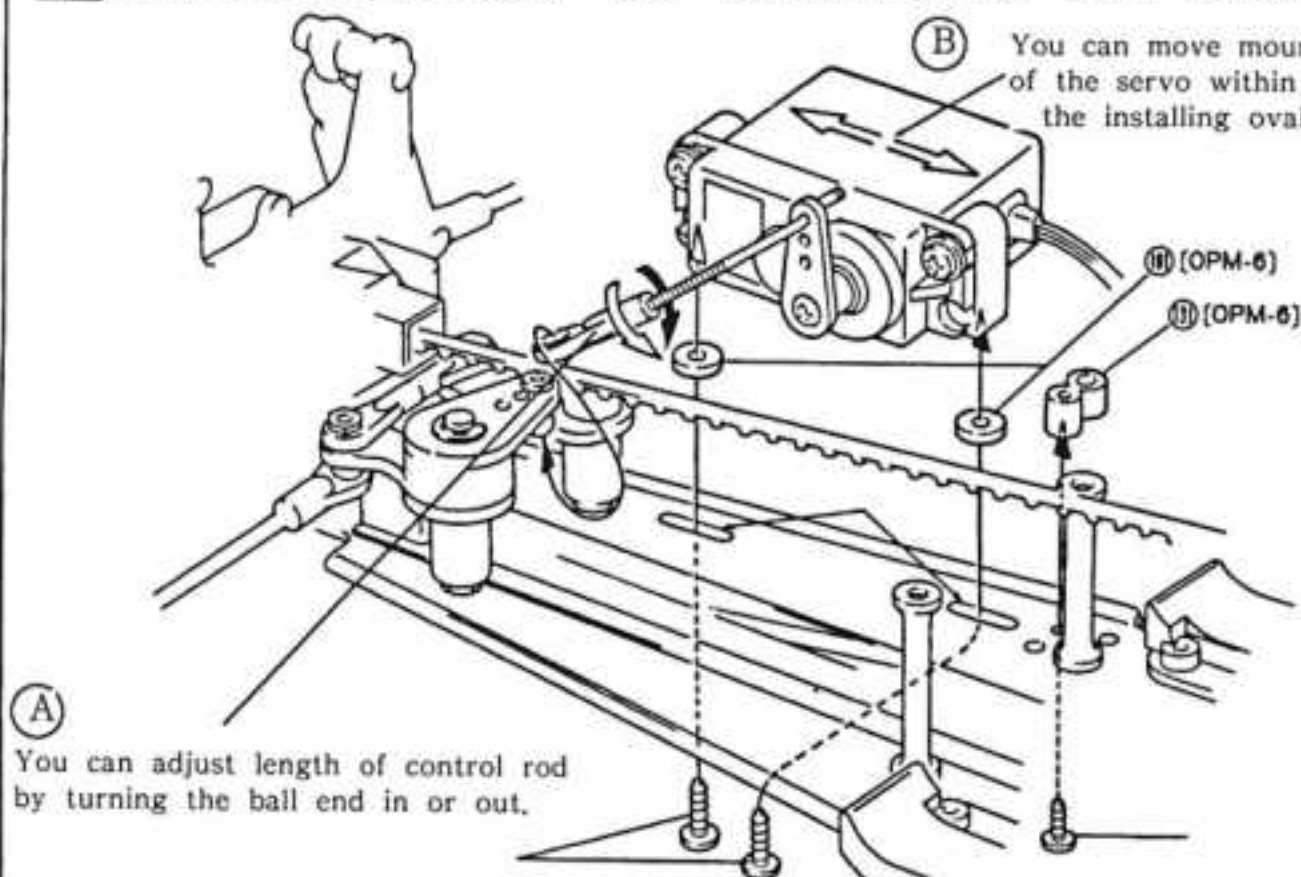

The servo horn is kept in neutral.

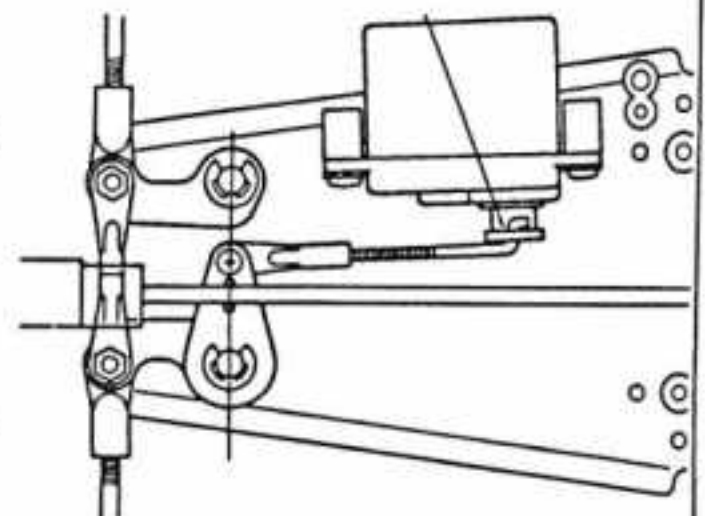

Set the adjustments (A) and (B) so that the servo will be mounted as shown in the drawing.

# 26 WIRING OF RECEIVER POWER SOURCE

**Step 2** Connect the cords of the switch and the regulator.



Any radio marked with this emblem does not require the wiring as shown in the drawing at right.

This model car has the only battery of 7.2V powering both radio control units and the propellant motor. If you feed the 7.2 volt directly to the radio units or arrange the positive and minus ends erroneously, you may break the receiver in a moment. Color coding of the lead cords varies depending upon the radio makers.

## Step 1

Cut off the switch from the battery case.

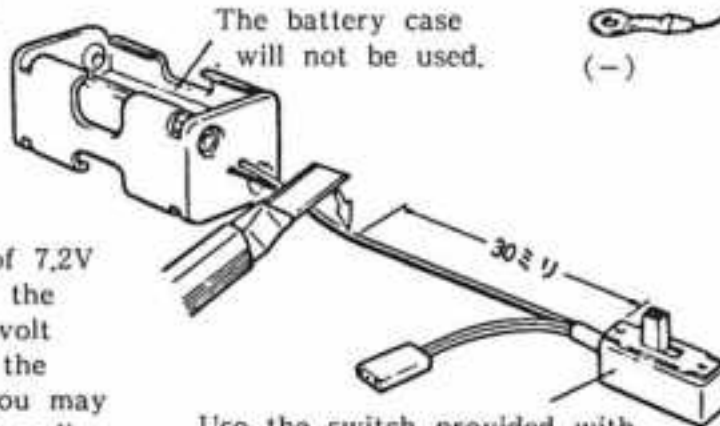

Use the switch provided with your radio control units.

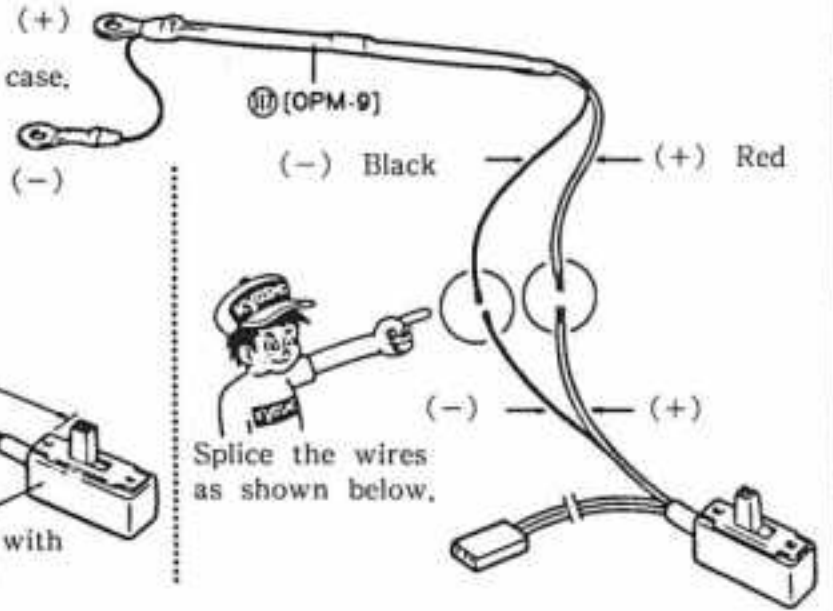

How to Splice Cords

1.

5 mm



Remove the insulation for 5 mm.

2.

Twist the wires, plus to plus and minus to minus.



You can make the connection more reliable by soldering the joint.

3.



Wrap up the joint with vinyl tape in order to avoid a short-circuit.

# 27 INSTALLATION OF UPPER DECK

## Step 1 (How To Install Switch)

Switch Plate

Use the screws provided with your radio units.

M2.6x6 TP Bind Screw

M3x6 Bind Screw

Install the upper deck through the belt loop.

(OPM-8)

M3x6 TP Bind Screw

M3x6 TP Flat Head Screw

M4x12 Bind Screw

## Step 2

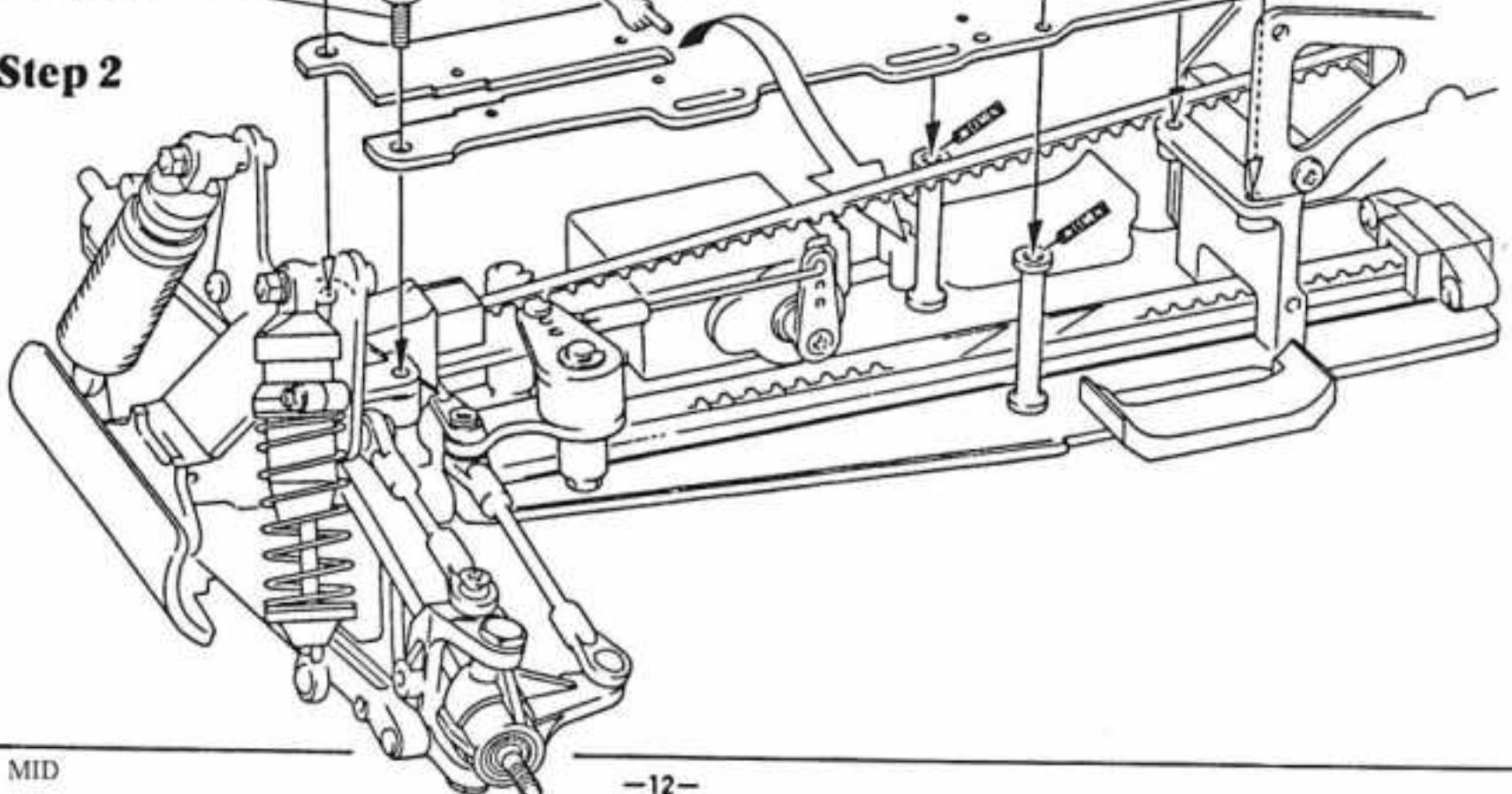

## 28 INSTALLATION OF BELT COVER (B),(C)

### Step 1

Cut off the shaded area along with the cutout line.

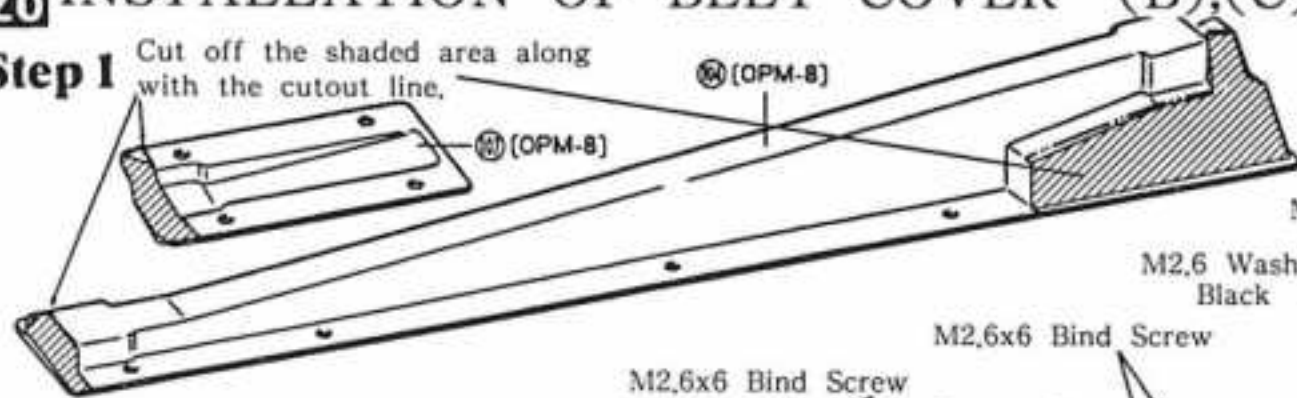

### Step 2

M2,6x6 Bind Screw

M2,6 Washer Black

M2,6x4 Bind Screw

Put a little amount of screw locking compound.

(Rear View)

### Step 3

After installing the belt cover, apply screw locking compound along the obliquely lined edges (both sides) as done in step ⑨.

Insert (107) under the upper deck from the side, and slide it forward.

Upper Deck

This area will contact the outlet part of the gearbox.

M2,6 Nut  
Put a little amount of screw locking compound to these four nuts.

Screw locking compound prevents dusts from entering through the belt cover and the chassis.

## 29 INSTALLATION OF MOTOR

### Step 1

Apply contact cement over the diagonally lined area, and stick it to the inside of the cover.

Before installing it, preformate the center part as shown.

### Step 2

Condensor

Route the lead wire through this hole.

White

Red

(+)

(-)

### Step 3

Arrange the motor cords out of these holes.

Take off the upper end of the right shock temporarily.

### Step 4

Set the setscrew to the flat on the shaft.

Step 5 After installing (129), fix the shock as it was before.

Cut off the striped area before fixing it.

<Adjustment of Backlash>  
Loosen the two screws marked with, and move the gear (128) to forward/rearward for the adjustment.

(Blister A)

M3x3 Set Screw

M3x10 Bind Screw

M3x4 Screw

(OPM-8)

# 30 ASSEMBLY OF SPEED CONTROLLER

## Step 1

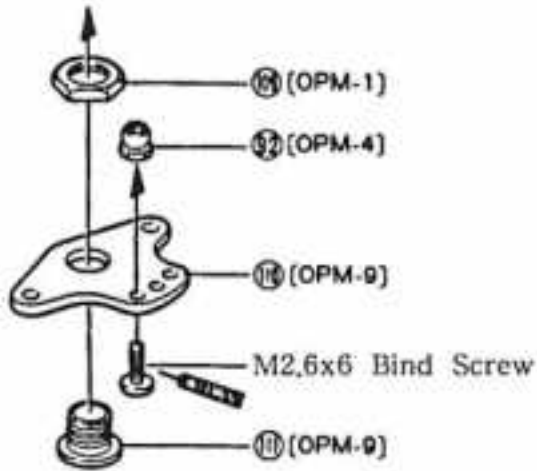

## Step 2

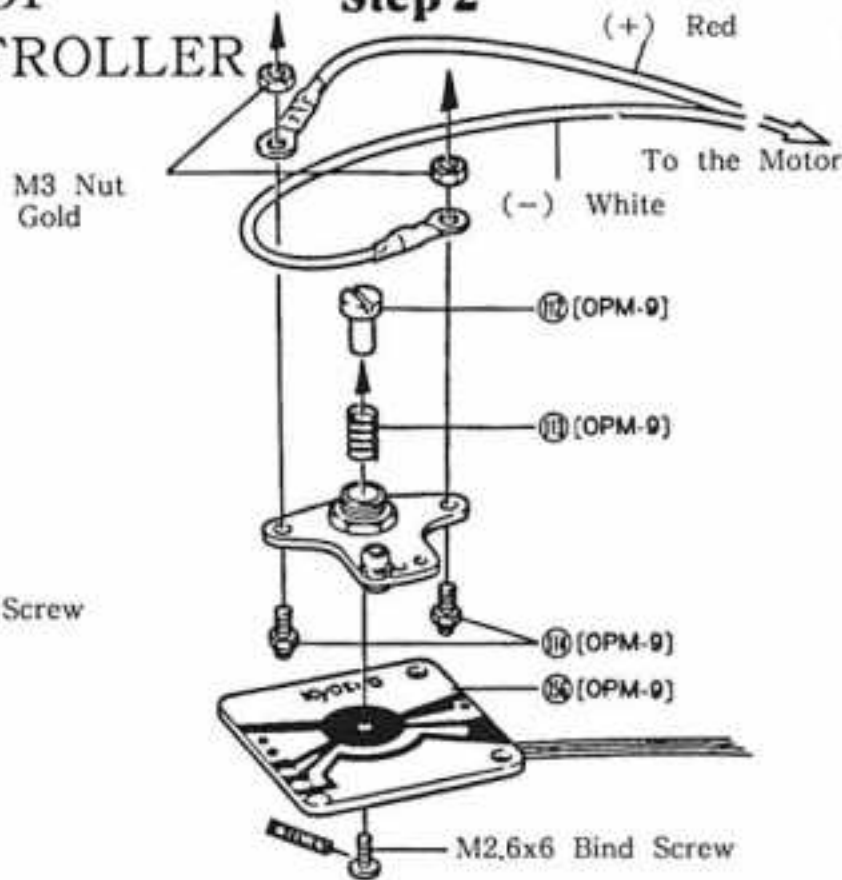

(+) Red

(-) Black

(OPM-9)

**BEC**  
BATTERY ELIMINATOR CIRCUIT

A set of radio control units contained in a box with this logogram is the BEC type. It does not need any regulator, or wiring illustrated in step 26 for the receiver. Be very sure not to make a mistake in connecting the positive and negative terminals.

Rout the cord through the triangle perforation.

## Step 3

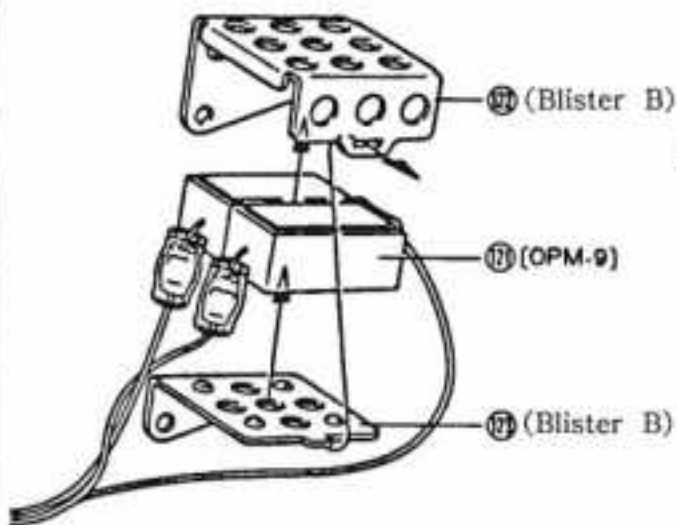

## Step 4

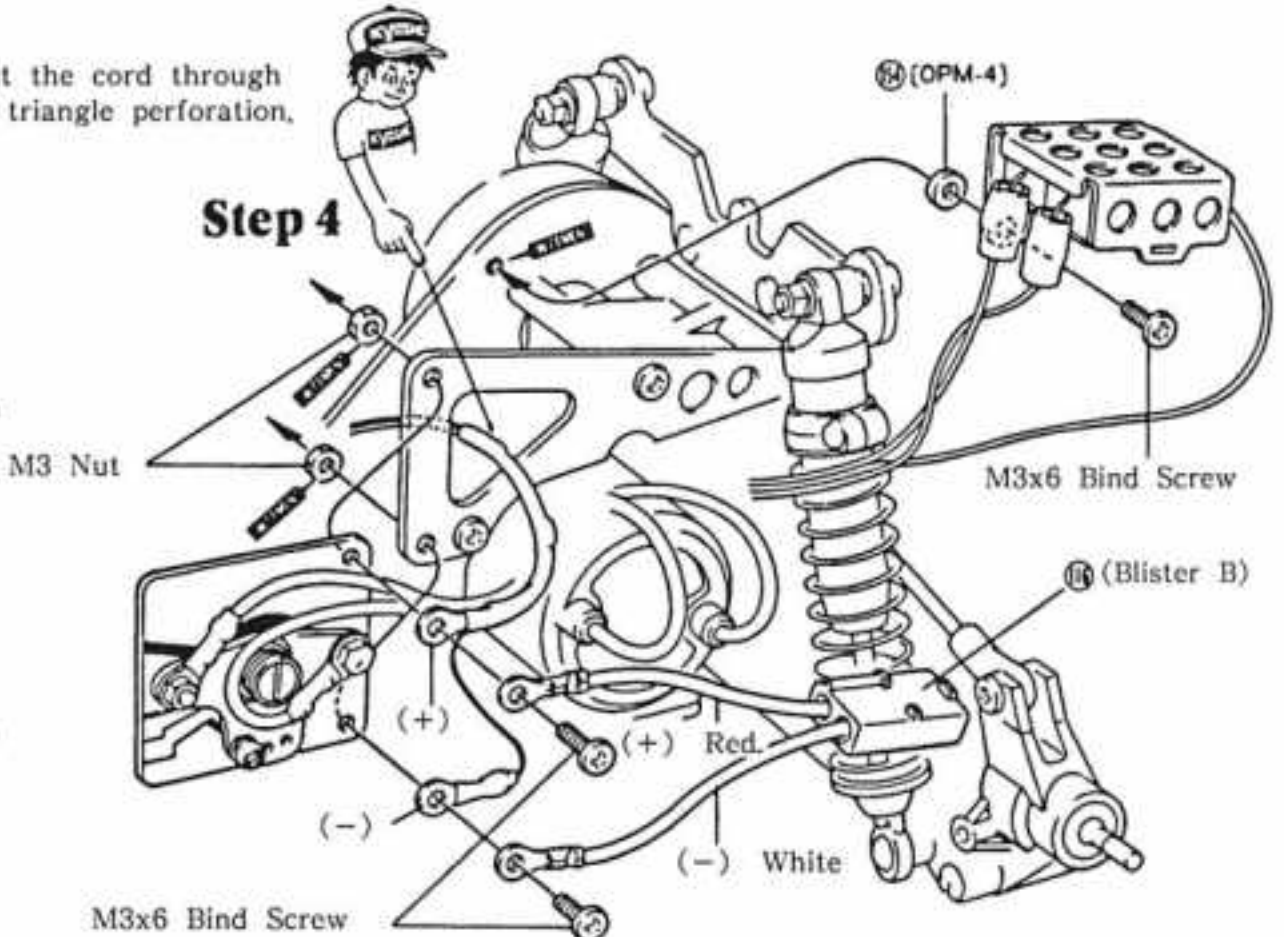

# 31 INSTALLATION OF SPEED CONTROL SERVO

## Step 1

Trimming of servo horn

Enlarge the hole with an awl to the size of control rod which will be connected in step 32.

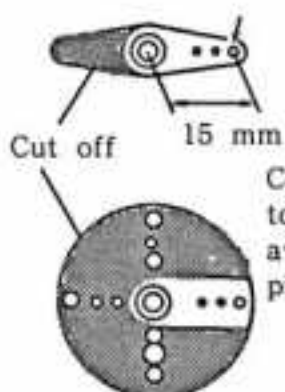

Connect the rod to the hole 15 mm away from the pivot center.

These parts will not be used with a small sized servo.

## Step 2

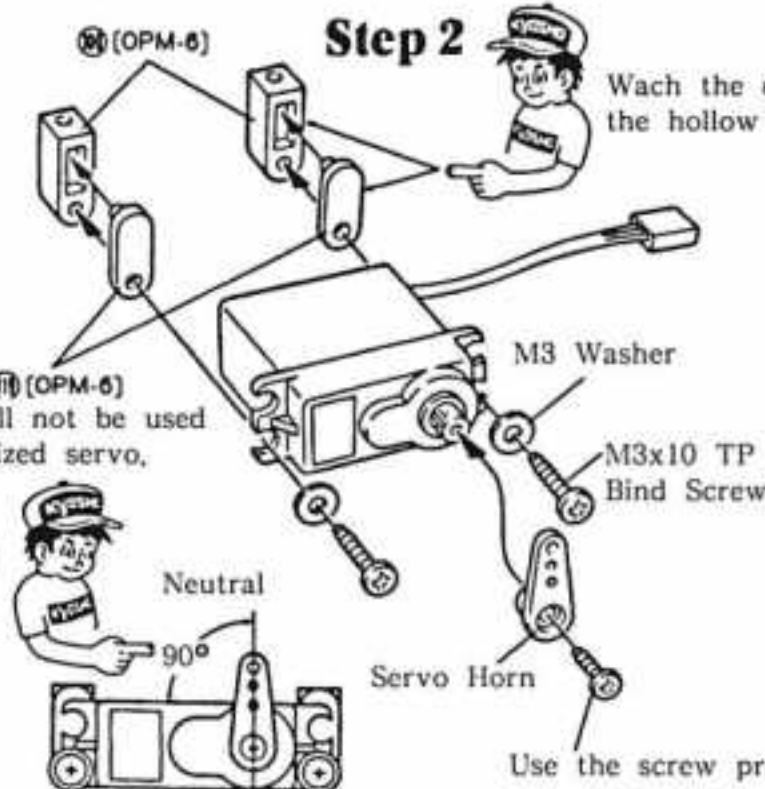

## Step 3

M3x10 TP Bind Screw

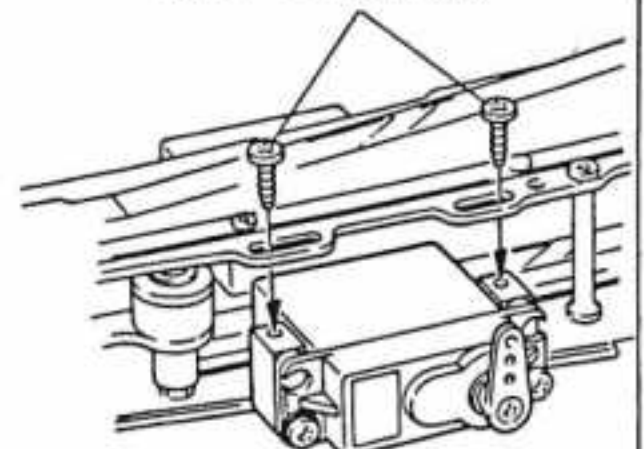

## 32 SPEED CONTROL LINKAGE

Assembly of control rod.

### Step 1

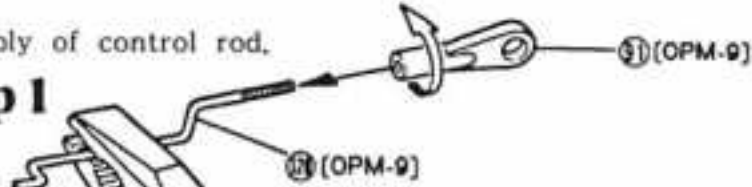

Fasten it firmly and cut off the excessive part at this point, (11) (OPM-9)

### Step 2

Cover the whole of the speed controller.

Dust Cover (OPM-9)  
Drill a hole for the control rod.

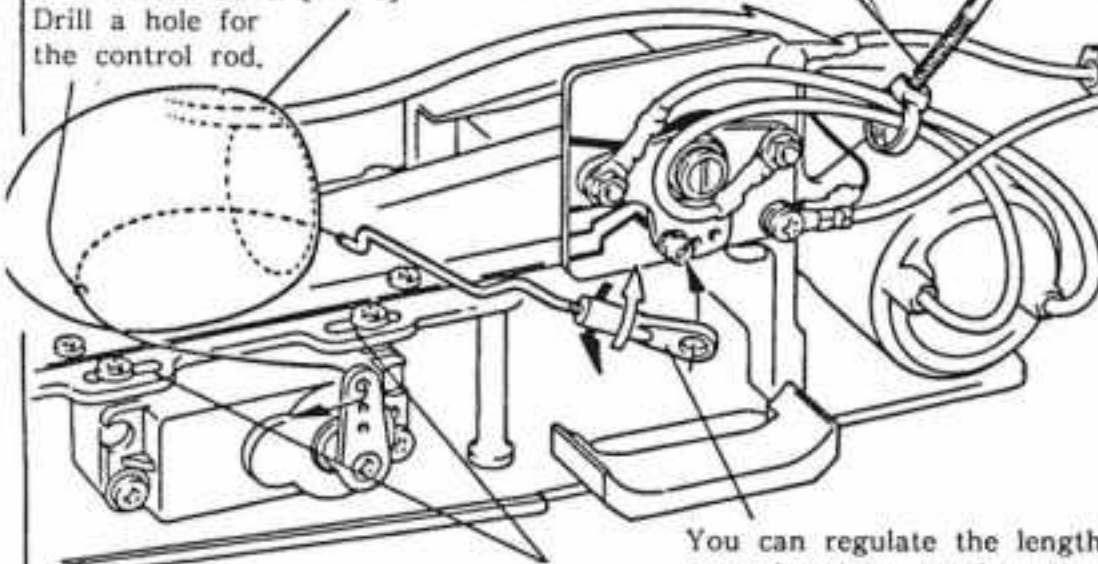

You can adjust position of the servo within the length of the oval hole.

You can regulate the length of control rod by turning the ball end in or out.

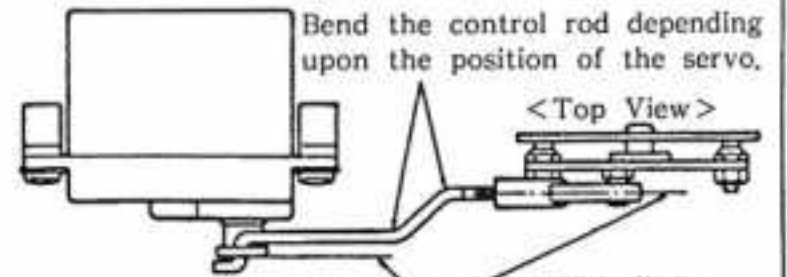

<Top View>

<Side View>

Parallel

If you find this point rubs against the control rod when you turn up the speed controller to the highest speed, bend the rod as shown.



NEUTRAL

LOW SPEED

MEDIUM SPEED

HIGH SPEED

REVERSE

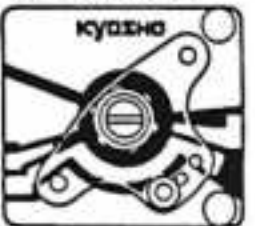
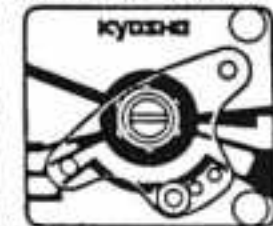
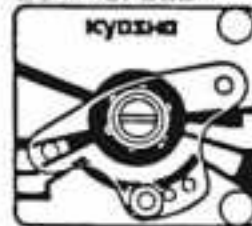
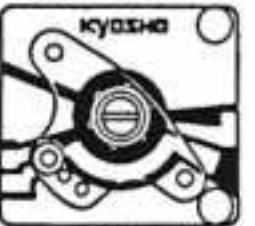

## 33 INSTALLATION OF RECEIVER

### Step 1

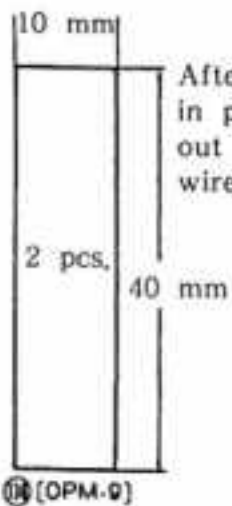

After fixing (132) in position, draw out the antenna wire.

(132) (OPM-8)

(132) (OPM-9)

Pass the antenna through the pipe.

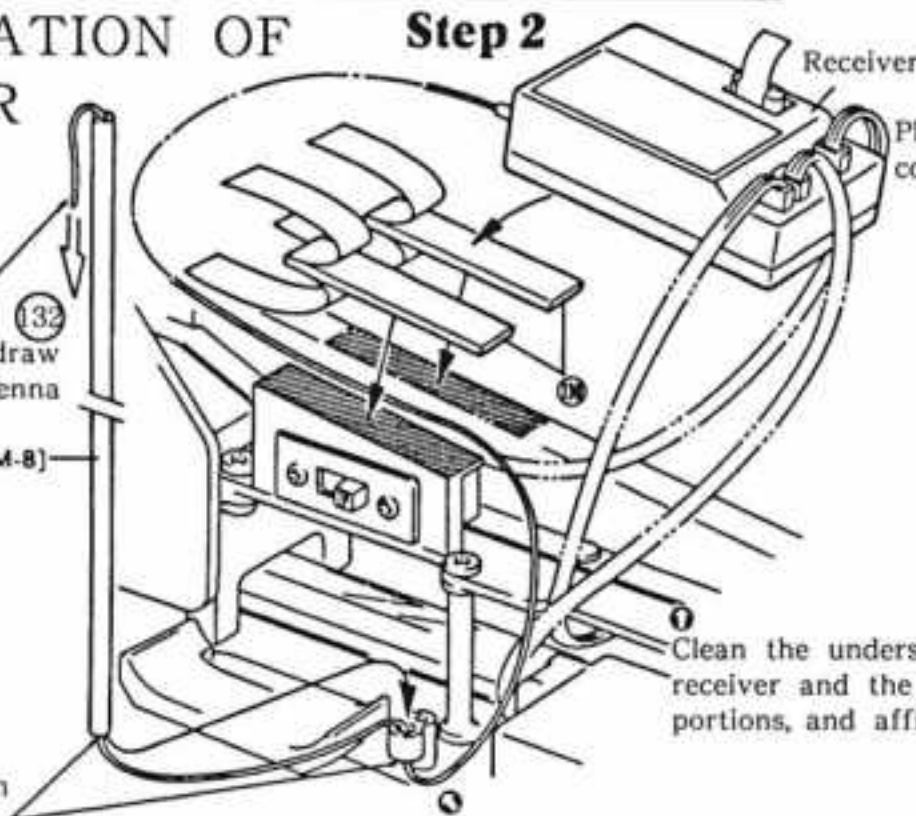

Receiver

Plug in the connector.

Clean the underside of the receiver and the shaded portions, and affix (130)

### Step 3

Bind the cords into a bundle.

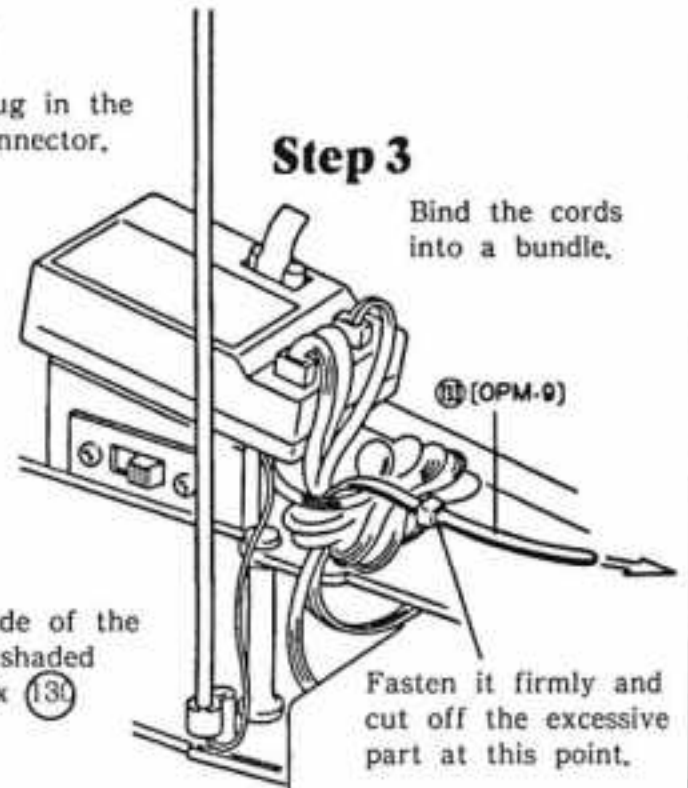

Fasten it firmly and cut off the excessive part at this point.

## 34 INSTALLATION OF WING STAY

\*All the parts, except screws, used in this step are packed in (OPM-6).

M2,6x12 TP Bind Screw

M2,6x12 TP Bind Screw

M3x30 Bind Screw

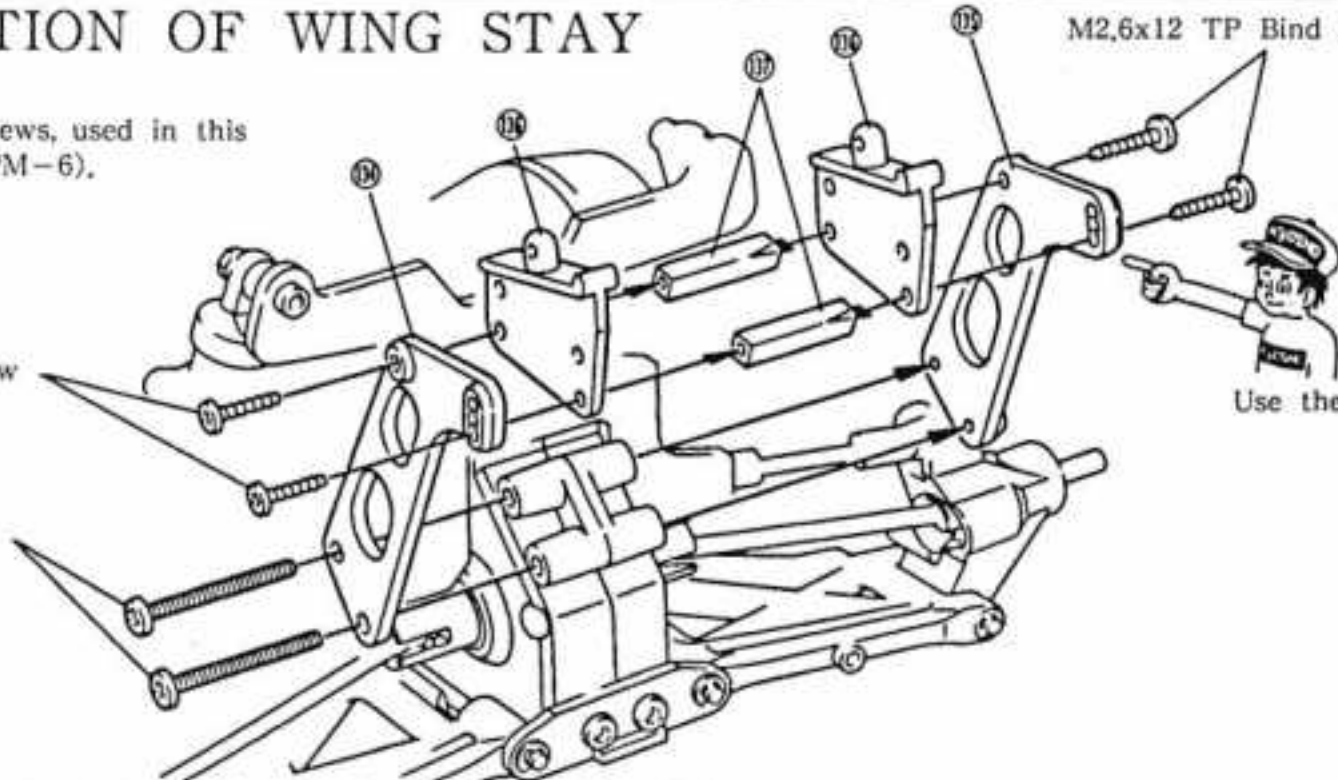

Use the bottom hole.

### 35 ASSEMBLY OF TIRE AND WHEEL

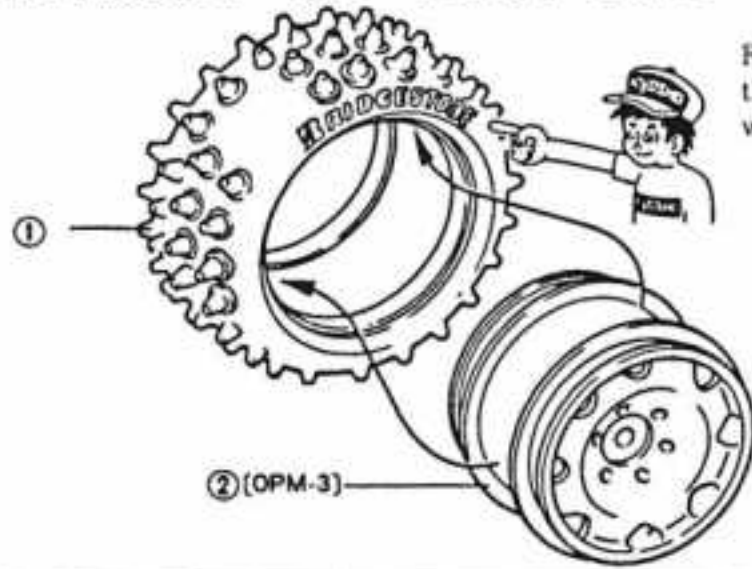

Fix the tire in such a way that the molded description will face toward the outside.

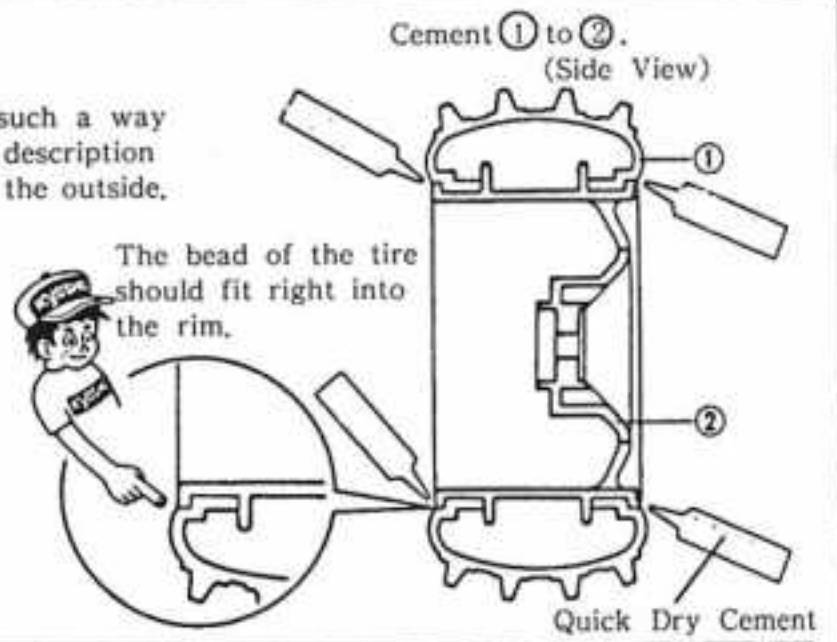

### 36 INSTALLATION OF TIRES

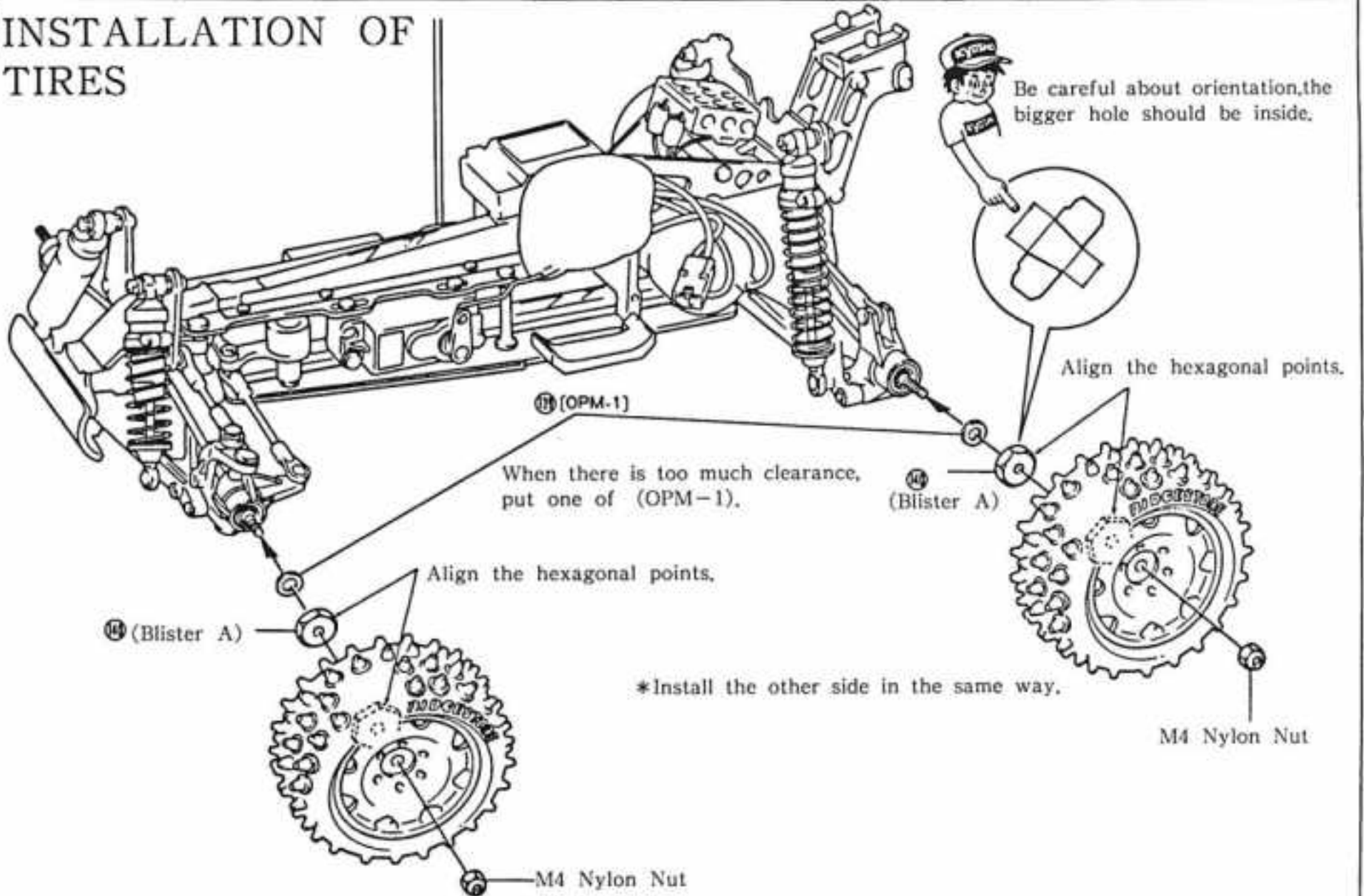

### 37 CUTTING OF BODY AND WING

Cut off a portion of the body if the heatsink comes to be.

The opening is for installing the body.

The opening is for installing the wing. (5φ)

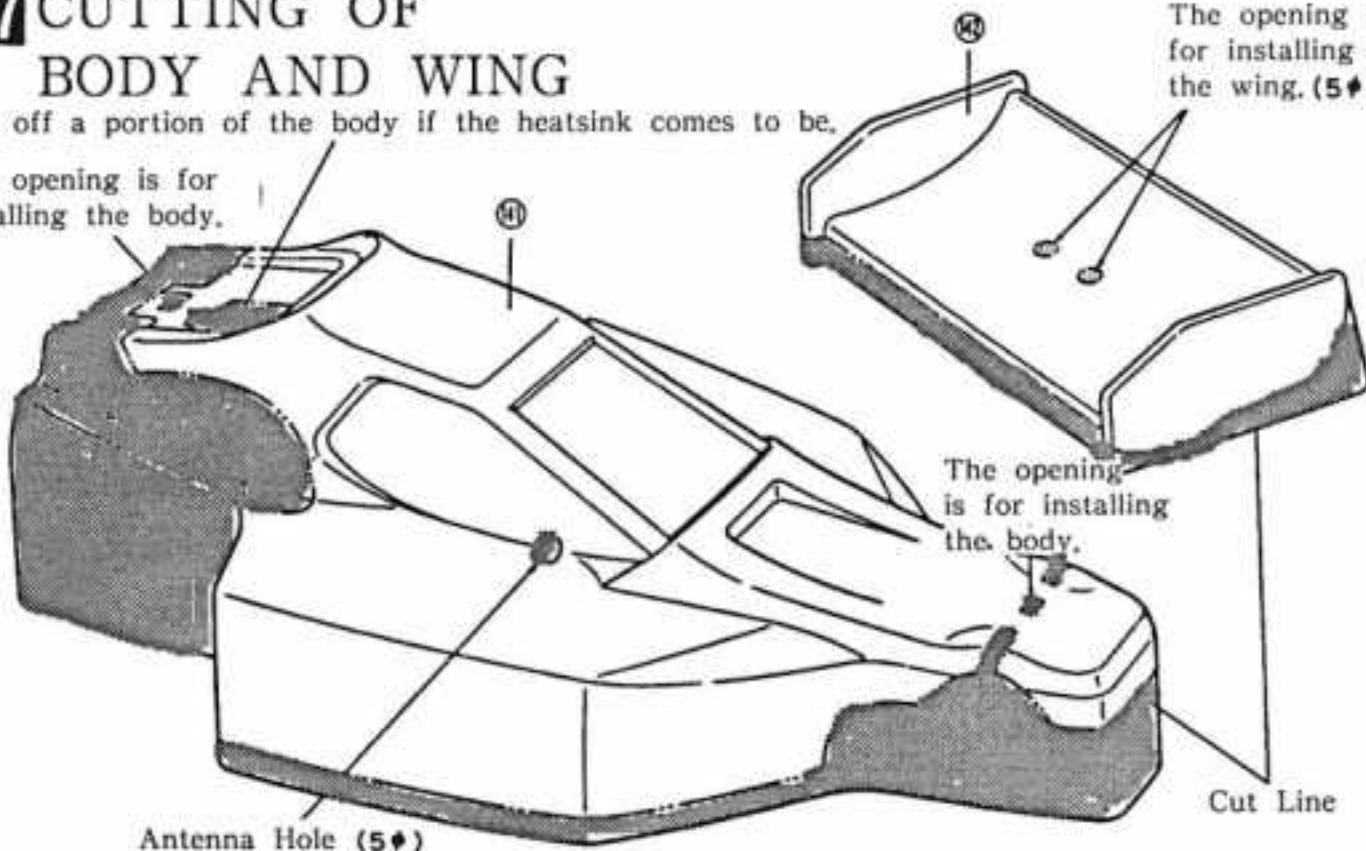

**KYOSHO** NO.1829

These special Lexan Scissors make trimming bodies a breeze and the sander comes in handy for finishing the rough edges.

Sander

### 38 PAINTING

First, wash the body to remove any oil or dirt. Rinse thoroughly. Paint the inside of the body. You can obtain a color scheme by masking a portion with tape then removing the tape and painting. Apply the lightest color last.

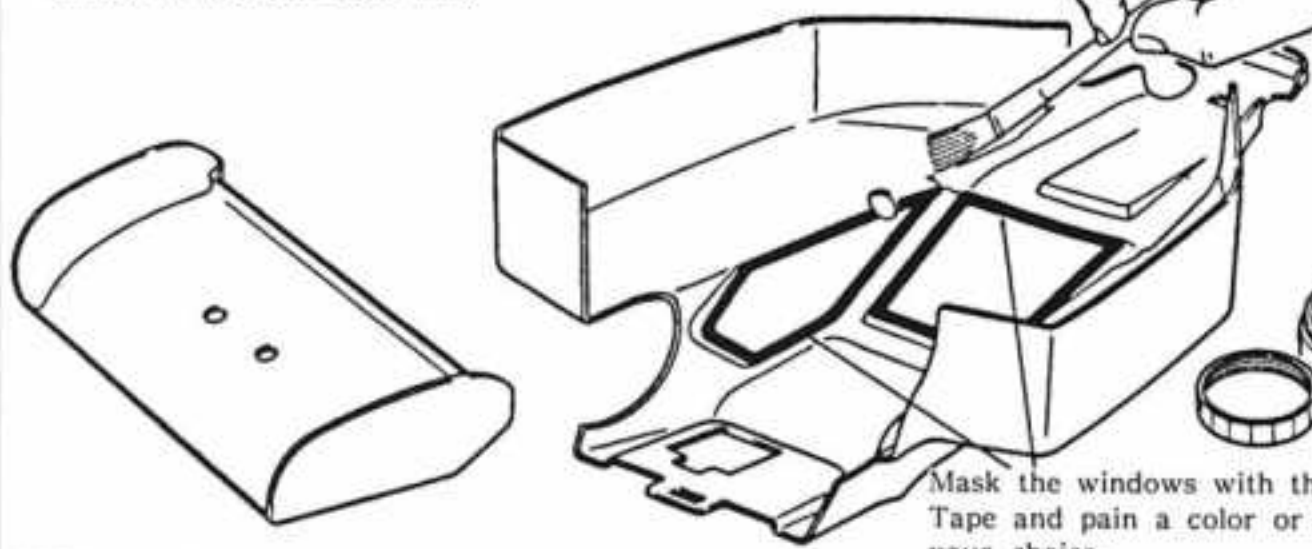

**KYOSHO**

Micron Line Tape

NO. 1841... 1 mm  
1842... 1.5 mm  
1843... 2.5 mm

Color

White, Red, Yellow,  
Green, Blue, Black



**KYOSHO**

Polica Color NO.2230  
White, Red, Yellow, Green,  
Blue, Skyblue, Orange,  
Black, Violet, F. Pink,  
Yellow Green, F. Orange



Mask the windows with the Micron Tape and pain a color or colors as your choice.

### 39 MOUNTING OF BATTERY

**CAUTION!**

\*When you keep the model not running for some time or stored, remove the battery from the model without fail.

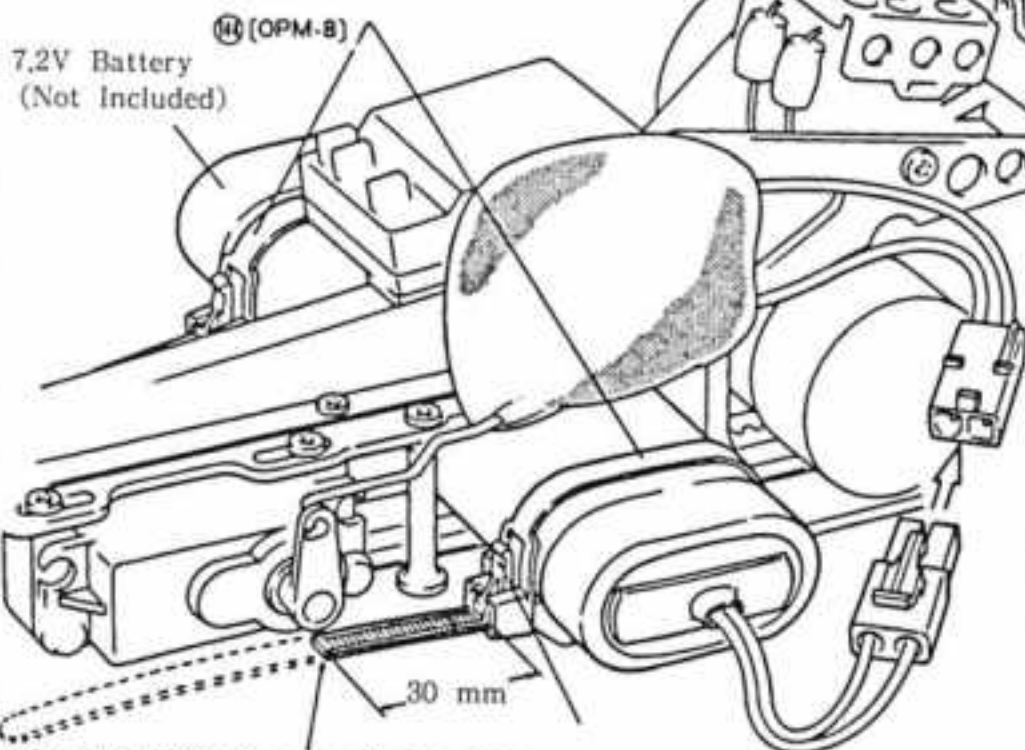

7.2V Battery  
(Not Included)

(14) (OPM-8)

For maximum performance, use a high performance battery.

The Kyosho 7.2V Power Battery or Racing Battery is recommended.

**KYOSHO**

NO.2306



NO.2218



After fastening it, cut off the strap at a point 30 mm from the clasp.

### 40 INSTALLATION OF BODY AND WING

Fix (38) with the fall surface downward.

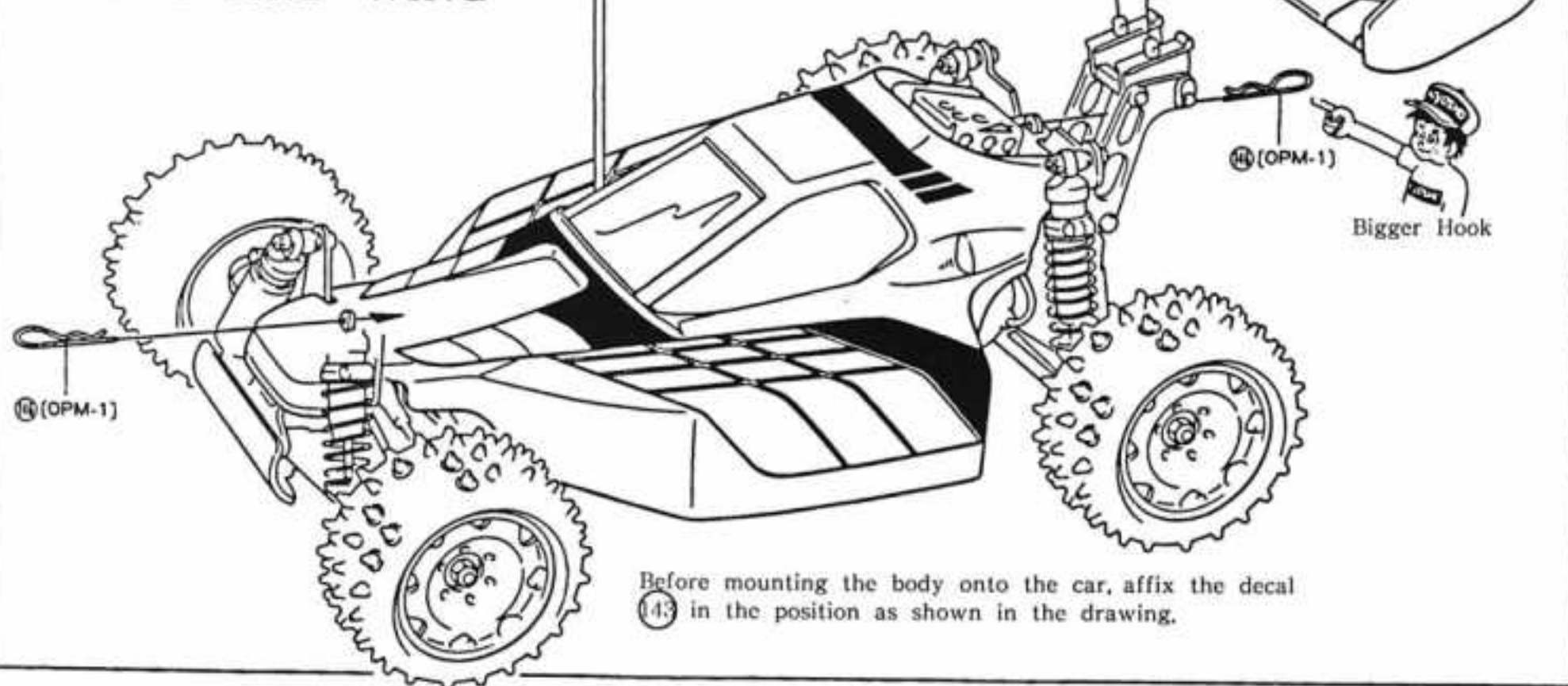

Before mounting the body onto the car, affix the decal (143) in the position as shown in the drawing.

# Guide for Characterizing "Optima Mid" (1)

(Basic Setting 1)

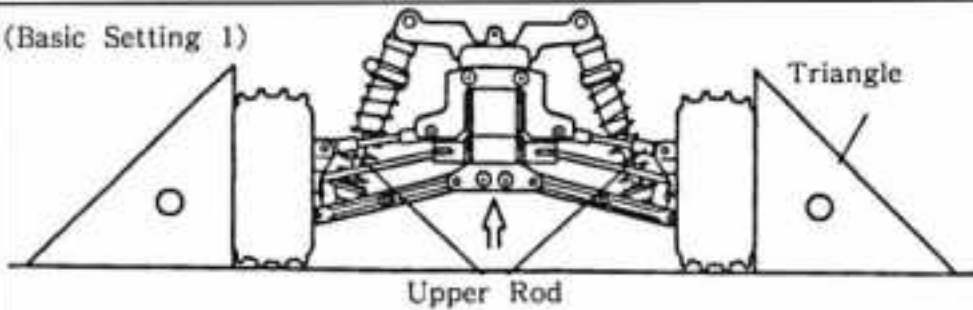

Place the model car on a flat surface, and keep the car with the maximum body clearance, and adjust length of the front and rear upper rods so that the wheels stand at a right angle to the ground.

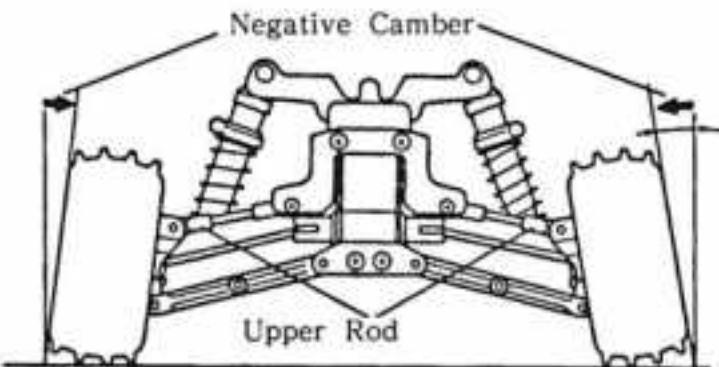

By adjusting the upper rod shorter, you will have a trait of negative camber. With negative camber adjustment on the front wheels, you will have sharper steering tendency, while on the rear wheel the gripping power becomes higher.

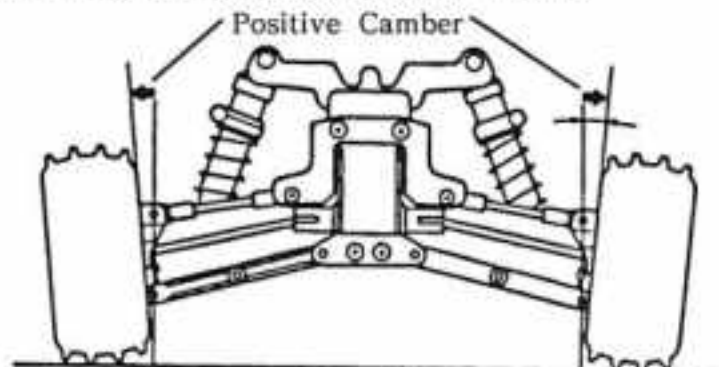

By lengthening the upper rod, positive camber adjustment is gained. With positive camber on the front wheels, you will have a trait of under steering, while on the rear wheels you will have the car with over steering traits.

\*Excessive positive camber adjustment may make the swing shaft dislocated.

(Basic Setting 2)

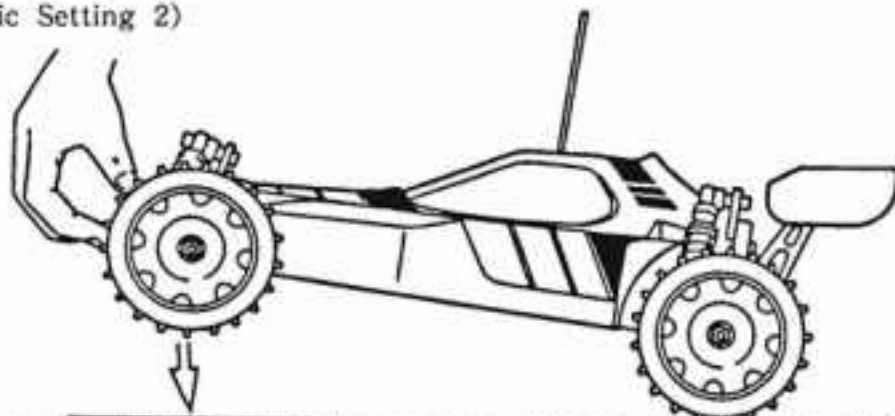

Adjust the right and left shocks in such a way that both sides of the front wheels will touch down the ground simultaneously when raising the front portion of the model and lowering it down gently. In the case the right and left side wheels land not in the same instant, the steering of each wheel will differ.

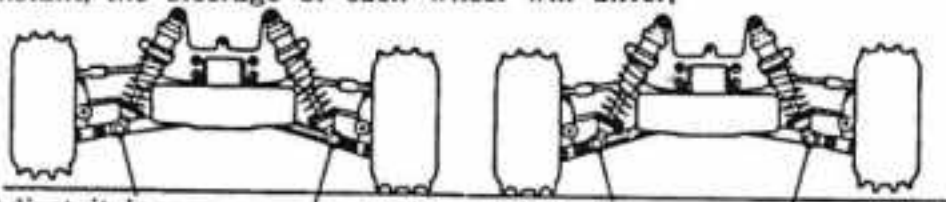

Adjust it longer, Make it shorter, Adjust it shorter, Make it longer.

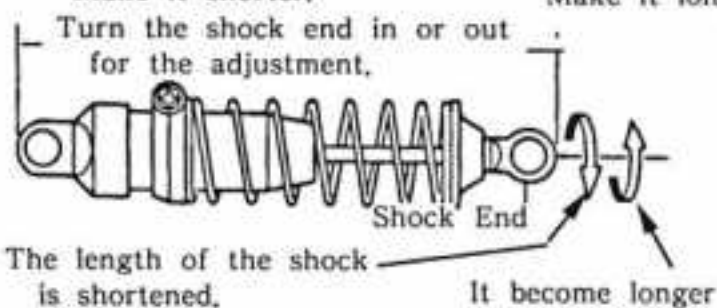

Turn the shock end in or out for the adjustment. The length of the shock is shortened. It become longer.

(Selection of Shock Oil and Adjustment of Spring)

Front	With lighter shock oil Lesser spring tension	-- Sharper steering response
Front	With heavier shock oil Harder spring tension	-- Slower steering response
Rear	With lighter shock oil Lesser spring tension	-- Hi-gher gripping power
Rear	With heavier shock oil Harder spring tension	-- Lower gripping power

(Landing Attitude After a Leap)

Harder spring tension of the front shocks and lighter oil in them will prevent a head down crash landing.

(Adjustment of Hardness of Shock Action)

NO.1951 Oil Set	Yellow	Green	Yellow	Red	Green	Red
Piston						
Hardness	← Harder			Softer →		

\*Take this chart just as general indication.

(Adjustment of Body Clearance)

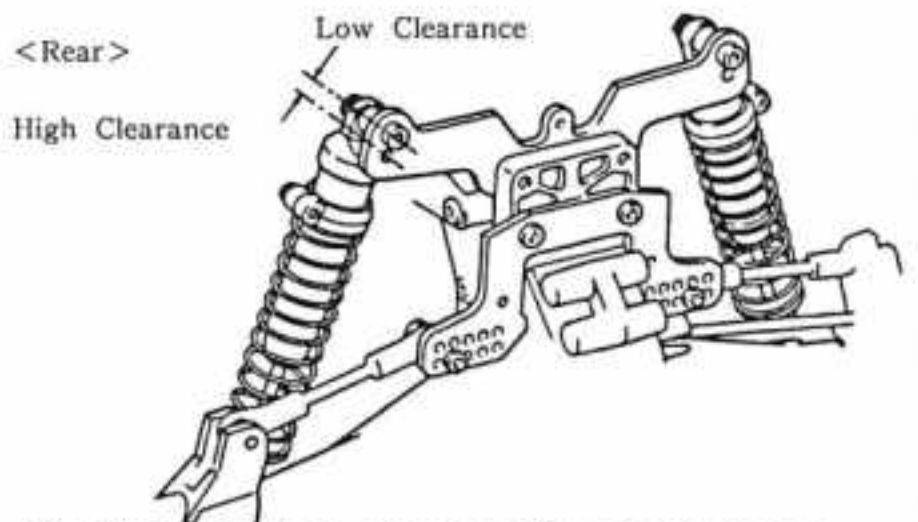
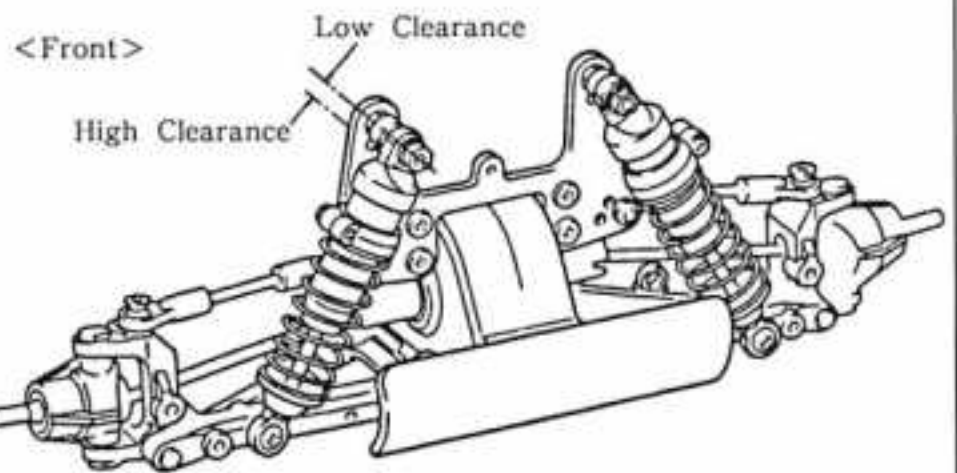

\*As illustrated above, you can adjust the car clearance. A general hint is that you will make the car clearance lower on a turf course where it provides good gripping, and on a track which gives you poor gripping you will set the clearance higher.

(Gear Ratios and Optional Motors)

Pinion Gear	15	16	17	18	19	20	21	22	23	24	25
Gear Ratio	13.04	12.22	11.50	10.87	10.29	9.78	9.31	8.89	8.50	8.15	7.82
Pro-per Motor	SPA 240 WS										
	Le Mans H240S										
	Le Mans 240ST							Le Mans 360Gold			

# Guide for Characterizing "Optima Mid" (2)

## (Modification of Tire)

By changing the shape of the knobs on the tire, you can improve the running performance of the car.

\*If your car displays the quick steering response, cut off the knobs by 1/2 to 1/3 then you can make it with milder response.

Let the knobs down.

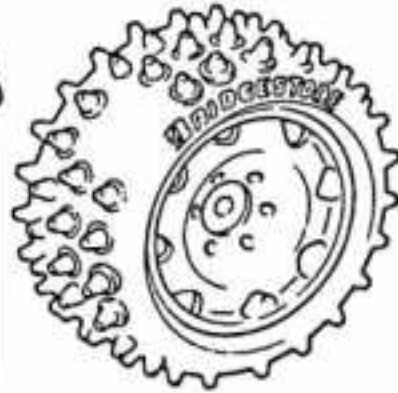

Type of Course Surface	Amount of Lowering Knob
Turf	Cut 1/2
Concrete	Cut 2/3
Sandy	No Cutting
Hard Dirt Track	Cut 1/3
Soft Dirt Track	No Cutting

\*In the "Option House" series, the W5031 Low Profile Tire (for hard surface) and the W5032 Low Profile Tire (for soft surface) are available.

## (Adjustment of Differential Gear)

The working of the differential gear system depends on amount and viscosity of the oil in the system. When you like to make it heavier, put more the 1952 Differential Oil, and to the other way, mix 10% to 20 % shock oil with the differential oil in the system.

## (Change of Steering Characteristics) by Adjustment of Differential

Adjustment of Differential	Steering Trait at Low Speed Cornering	Steering Trait at High Speed Cornering
Front Differential (Heavier)	Neutral Steering	Under Steering
Rear Differential (Heavier)	Under Steering	Over Steering
Both Front and Rear (Lighter)	Over Steering	Neutral Steering

\*This is just a rule of thumb

## (Maintenance of Speed Controller)

Wipe the contact with a brush or cloth.

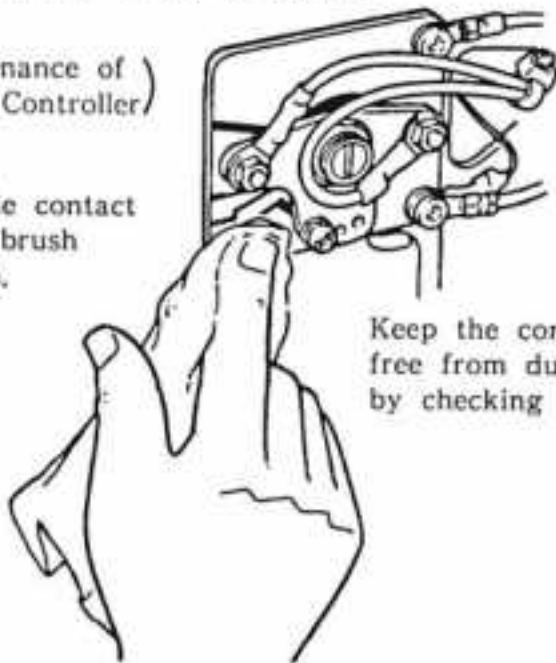

Keep the contact point free from dust and stain by checking it regularly.

## (Maintenance of Sprocket)

Dust or other foreign articles are subject to be accumulated on cogs of the sprockets in front and rear.

Check them from time to time.

## (Correlation between the Position of Front Upper Rod and Camber Angle)

The installing points A,B, and C on the front shock stay for the upper rod correspond to A',B' and C' which are the maximum chamber angle when the front suspension arms swing down to the lowest position.

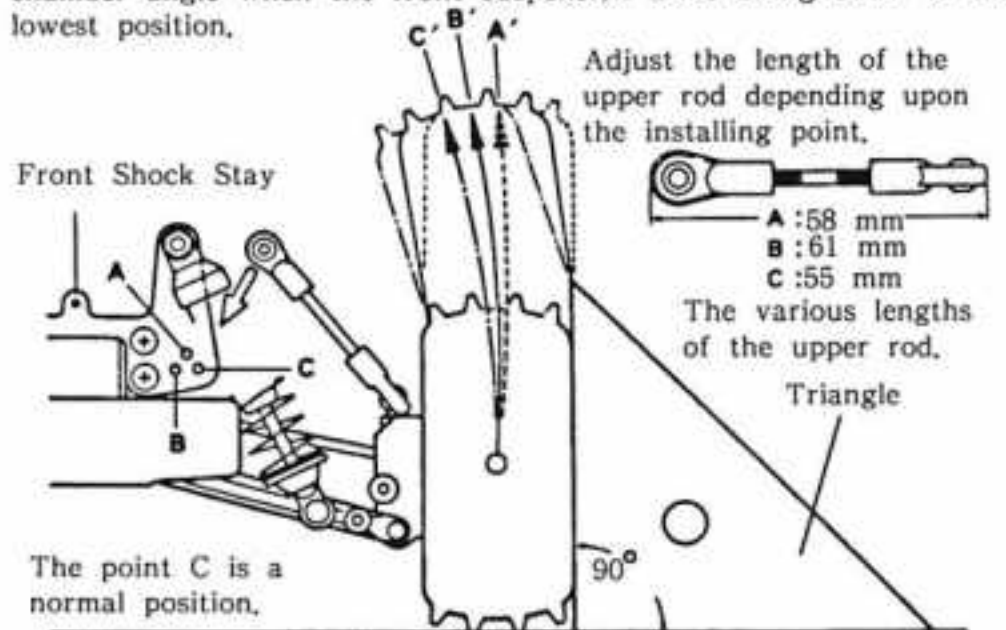

## (Correlation between Installing Position of the Rear Upper Rod and Chamber Angle)

The installing points A,B,C, and D on the upper rod plate will result in the positions of the rear camber angle A',B',C' and D' when the rear suspension arms sink the most.

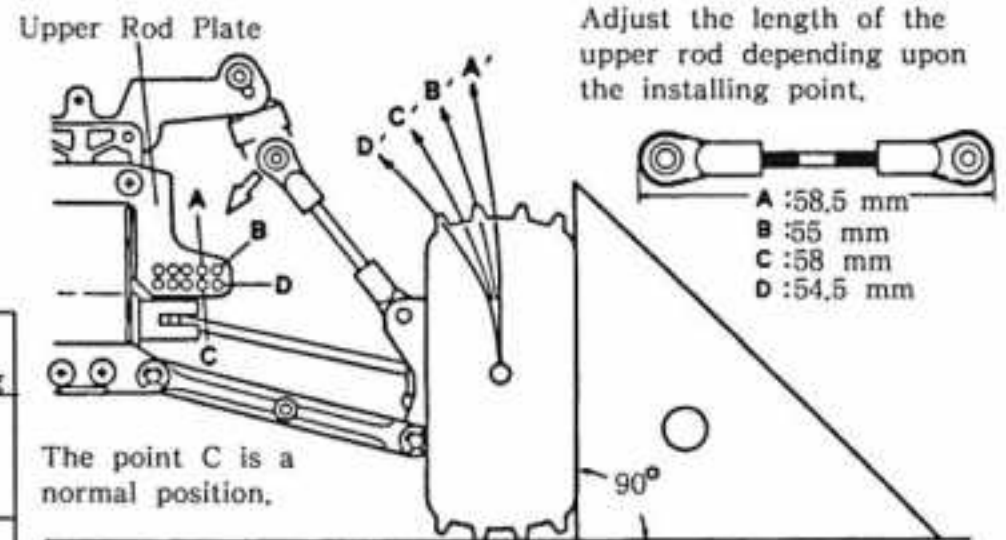

## (Adjustment of Belt tension)

This model is so designed that the belt is engaged rather tightly. If you find it too tight to let it go smoothly, enlarge the hole on the upper deck toward the front end, and reassemble it by pushing the front gear box from the front and tightening the screw.

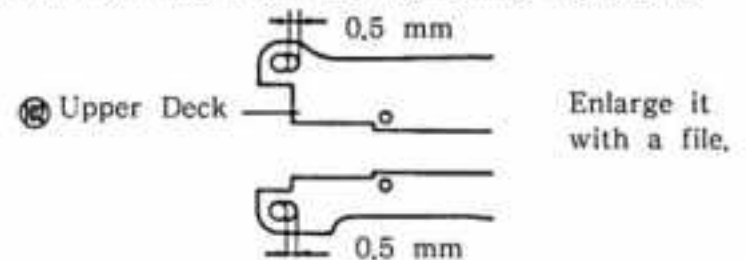

## (Adjustment of Wing Stay)

When fastening the wing stay B to the wing stay A, the assembled angle of the two components will be bigger in order from A to B to C fixing points.

- 1...Use these upper holes, if you like to make the wing low.
- 2...Use these lower holes, if you like to make the wing high.



## Things to Observe

### (Running the Optima Mid)

This model has only Ni-Cad battery powering the motor, receiver and servos at a time. Whenever you notice the car losing the speed, discontinue the operation, otherwise your car will go out of control.

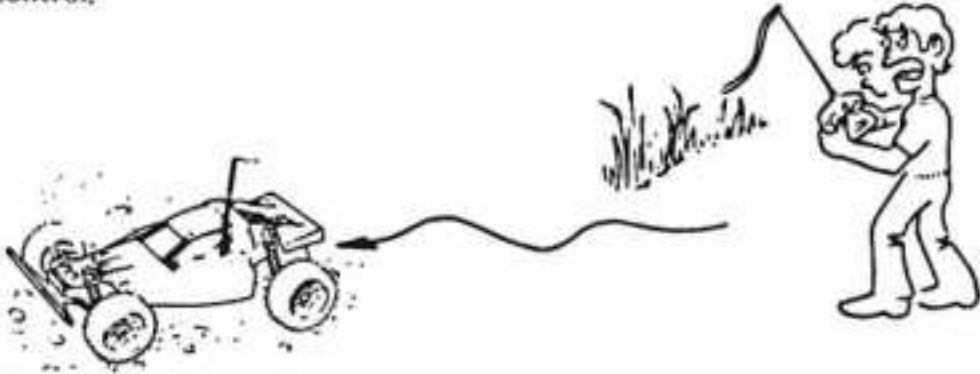

### (After Running)

After you had a pleasure of running your car, unplug the connector from the battery. And store the battery separately from the model.

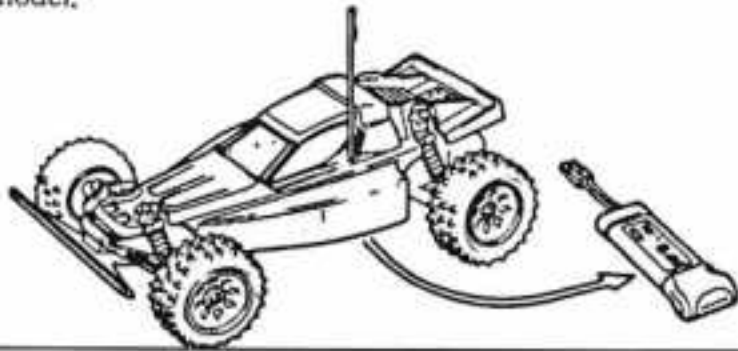

### (Checking Your Car before Running)

\*When you have your car run for the first time, drive it slowly for the duration of one to three charges of the Ni-Cad battery.

- (1) Check to see if all bolts and nuts are tightened firmly.
- (2) Check to see if Ni-Cad battery is fully charged.
- (3) Check to see if the steering and the speed control is in proportion to your control of the transmitter.
- (4) Check to see if all wiring are properly secured.
- (5) Check to see if all rotating parts move smoothly.

### (Operation Procedures)

- (1) Turn on the switch of the transmitter.
- (2) Turn on the switch of the receiver.
- (3) Test the operation of the radio control units.

\*When turning off the switches, turn off the receiver first, then the transmitter. If you don't keep this order, your model may start to run haphazardly.

### (Trouble Shooting)

- (1) Poor contact of batteries, connectors, and speed controller.
- (2) Check to see if the Ni-Cad battery is properly charged.
- (3) Check to see shortage of battery power for the transmitter.
- (4) Check to see if there is no signal interference by other radios.

## Dos and Don'ts for Operation

Radio controlled model cars are powered by high effective Ni-Cad battery and can attain great speed. You are required to be very careful in handling them.

- Do not use the streets for running model cars.
- Two cars under the same frequency cannot run at a time. When there is another model going in the same time, compare the frequency of your radio with his.
- When your car stalled, or being caught by some obstacles, do not continue running forcibly. The motor and wiring may be burnt down or damaged.
- Do not grab the rotating wheels.
- Before connecting the Ni-Cad battery, confirm that the speed controller is positioned in neutral.
- If the bearing in the driving train do not rotate smoothly, the motor and battery may be loaded excessively, resulting in losing speed or overheating. Check always that the drive train will turn lightly and grease the bearings from time to time.
- The car with one battery for both motor and radio units will lose control as the battery power is falling. When the car slows down, stop the running.

## Maintenance after Running The Car

- Remove the Ni-Cad battery from the car.
- Wipe dirt and oily stain off the car.
- Turn off the switches of the radio control units.
- Grease the moving parts periodically.
- Tighten the loose screws and nuts, if any.

## Handling the Motor

- The motor generates heat while it is running. A continuous running of the motor may shorten its span of life. Do not operate the motor until it cools off.
- Several times of running of the motor will decrease the power, since carbon has been accumulated on the commutator. Remove the pinion gear and run the motor without load under 7.2 volts for about 15 minutes for cleaning the commutator.
- Oil the motor bearings at regular intervals.

## Exploded View of Front & Rear Differential Gears

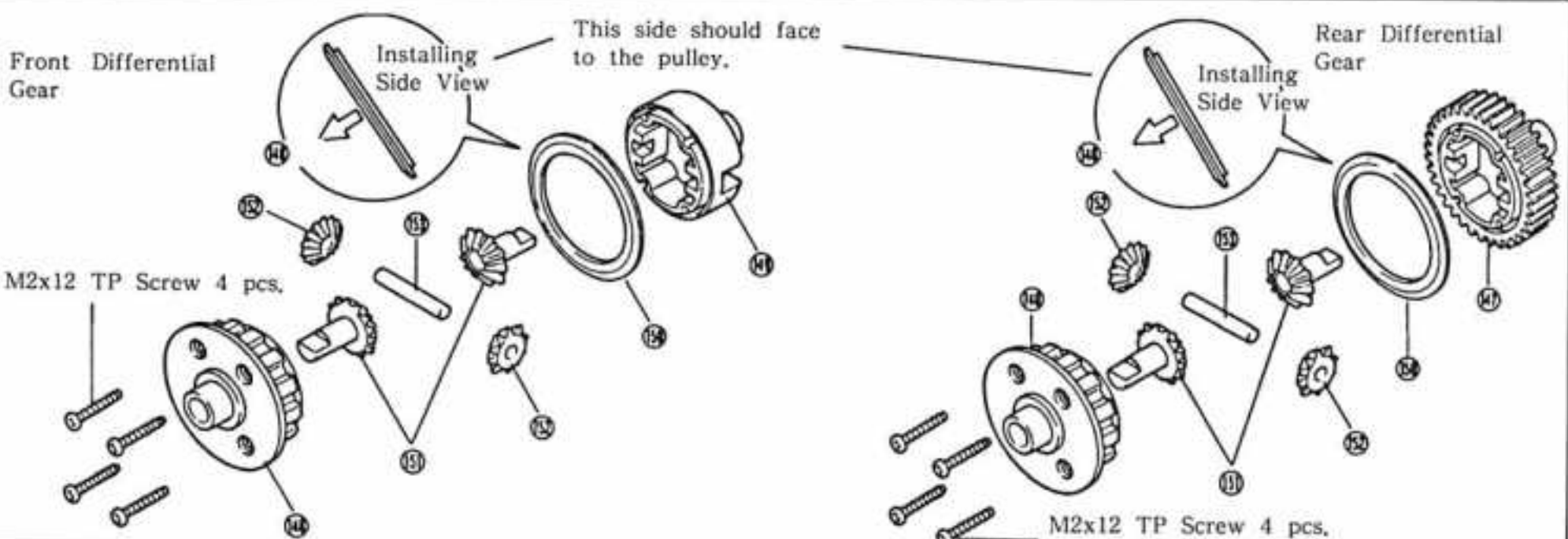

## "OPTIMA MID" KEY NUMBERS FOR PARTS

NO.	PARTS NAME	Q'TY	NO.	PARTS NAME	Q'TY	NO.	PARTS NAME	Q'TY
1	Tire	4	54	Front Suspension Arm	2	107	Rubber Cover (C)	1
2	Wheel	4	55	M3 Pillow Ball (Silver)	4	108	Allen Wrench (1.5 mm)	1
3	8 $\phi$ x14 Ball Bearing	4	56	Front Stabilizer End	2	109	Speed Control Nut	1
4	Joint	4	57	E Ring (E-3) (Black)	2	110	Speed Control Horn	1
5	Allen Wrench (2 mm)	1	58	Suspension Shaft (A)	2	111	Speed Control Pivot	1
6	Rear Gear Box (R)	1	59	: (B) (Silver)	2	112	Speed Control Stud	1
7	5 $\phi$ x10 Ball Bearing	10	60	E Ring (E-2.5)	20	113	Speed Control Spring	1
8	Spur Gear Shaft	1	61	5.8 $\phi$ Ball (Black)	4	114	Speed Control Contact	2
9	2 $\phi$ x11 Pin	1	62	Allen Wrench (2.5 mm)	1	115	Motor Cord	2
10	Counter Gear	1	63	Ball End (L)	12	116	Connector (7.2V)	1
11	E Ring (E-4)	4	64	Upper Rod	4	117	Regulator	1
12	5 $\phi$ x8 Ball Bearing	2	65	Rear Hub (R)	1	118	BEC Connector	1
13	Pulley (Yellow)	1	66	Rear Hub (L)	1	119	Servo Spacer	2
14	Pulley Flange (Yellow)	1	67	Rear Shaft	2	120	Speed Control Rod	1
15	5 $\phi$ Collar (S) (Yellow)	2	68	Rear Suspension Arm	2	121	Resistor	1
16	4 $\phi$ x8 Ball Bearing	2	69	Suspension Shaft (C) Black	2	122	Heatsink (A)	1
17	Center Gear	1	70	Suspension Shaft (D)	2	123	Heatsink (B)	1
18	Center Gear Shaft	1	71	Rear Suspension Plate	1	124	Motor	1
19	Toothed Belt	1	72	Swing Shaft	4	125	Motor Cover	1
20	Rear Gear Box (L)	1	73	Shock Oil	1	126	Motor Cleaner	1
21	Rear Plate (L)	1	74	Front Shock Case	2	127	Motor Plate	1
22	Rear Plate (R)	1	75	Rear Shock Case	2	128	Pinion Gear (20T)	1
23	5 $\phi$ Collar (L) (Yellow)	1	76	Shock Piston	4	129	Gear Cover	1
24	Gear Protector Plate (B)	1	77	Front Shock Shaft	2	130	Double Sided Tape	1
25	Gear Protector Washer	2	78	Rear Shock Shaft	2	131	Antenna Post	1
26	Spur Gear	1	79	Shock O Ring (Red)	8	132	Antenna Pipe	1
27	Gear Protector (A)	1	80	Shock Collar (White)	4	133	Strap (S)	3
28	Wave Washer	3	81	Plastic Washer (Black)	4	134	Wing Stay (A) (L)	1
29	Gear Protector Collar	1	82	C Ring	4	135	Wing Stay (A) (R)	1
30	Upper Rod Plate	1	83	Shock Cap	4	136	Wing Stay (B)	2
31	Rear Shock Stay	1	84	Pressure Top	4	137	Wing Stay Joint	2
32	Front Gear Box (R)	1	85	Spring Stopper	4	138	Wing Washer	2
33	Front Gear Box (L)	1	86	Shock End	4	139	5 $\phi$ Shim	8
34	Front Shock Stay	1	87	Front Spring	2	140	Drive Washer	4
35	Front Suspension Plate	1	88	Rear Spring	2	141	Body	1
36	Chassis	1	89	Spring Holder	4	142	Wing	1
37	Bumper	1	90	Shock Bushing	4	143	Decal	1
38	Belt Cover (A)	1	91	Ball End (S)	4	144	Ni-Cad Strap	2
39	One Touch Tape	2	92	Ball Nut	4	145	Wing Pin	2
40	Sponge Tape	2	93	Servo Saver (A)	1	146	Body Pin	2
41	Saver Shaft	2	94	Servo Saver (B)	1	147	Main Gear	1
42	Upper Deck Post	2	95	Servo Saver (C)	1	148	Sprocket	2
43	Upper Deck Mount	1	96	Servo Saver (D)	1	149	Differential Gear Case	1
44	Rear Suspension Pivot	1	97	Servo Saver Collar	2	150	Differential Gear Ring (Y)	2
45	Battery Holder	2	98	Tie Rod	2	151	Bevel Gear (A)	4
46	Knuckle Arm (L)	1	99	Steering Rod	1	152	Bevel Gear (B)	4
47	Knuckle Arm (R)	1	100	Servo Stay	4	153	Bevel Gear Shaft	2
48	Front Shaft	2	101	Servo Stay Spacer	2	154	Heatsink Collar	1
49	M2.6 Pillow Ball (Black)	4	102	Upper Deck	1	155	M3 Plastic Nut	4
50	Front Hub (R)	1	103	Switch Plate	1	156	Speed Control PC Board	1
51	Front Hub (L)	1	104	Belt Cover (B)	1	157	Silicone Grease	1
52	King Pin	4	105	M2 Shaft	1	158	Screw Locking Compound	2
53	5.8 $\phi$ Ball (Silver)	4	106	Rubber Cover	1		Motor Condenser	1

# "OPTIMA MID" BAGGED PARTS LIST (1)

BAG.	NO.	PARTS NAME	Q'TY	Step	
Blister (A)	4	Joint	4	1	
	10	Counter Gear	1	2	
	17	Center Gear	1	2	
	26	Spur Gear	1	3	
	42	Upper Deck Post	2	4	
	46	Knuckle Arm (L)	1	11	
	47	Knuckle Arm (R)	1	11	
	48	Front Shaft	2	11	
	67	Rear Shaft	2	12	
	72	Swing Shaft	4	13 14	
	128	Motor Pinion Gear (20T)	1	29	
	140	Drive Washer	4	30	
Blister (B)	3	8 φ x14 Ball Bearing	4	1	
	7	5 φ x10 Ball Bearing	10	2 11 12	
	12	5 φ x8 Ball Bearing	2	2	
	16	4 φ x8 Ball Bearing	2	2	
	19	Toothed Belt	1	2	
	54	Front Suspension Arm	2	12	
	68	Rear Suspension Arm	2	14	
	116	Connector (7.2V)	1	10	
	122	Heatsink (A)	1	10	
	123	Heatsink (B)	1	10	
	124	Le Mans 240ST Motor	1	29	
	Ass'y	Front Differential Gear	1	1	
	Ass'y	Rear Differential Gear	1	1	
	Ass'y	Pressure Oil Shock (S)	2	19	
Ass'y	Pressure Oil Shock (L)	2	19		
OPM-2	6	Rear Gear Box (R)	1	2	
	20	Rear Gear Box (L)	1	2	
	32	Front Gear Box (R)	1	5	
	33	Front Gear Box (L)	1	5	
	60	E Ring (E-2.5)	4	19	
	73	Shock Oil	1	20	
	76	Shock Piston	4	19	
	79	Shock O Ring (Red)	8	19	
	80	Shock Collar (White)	4	19	
	81	Plastic Washer (Black)	4	19	
	82	C Ring	4	19	
	84	Pressure Top	4	20	
		Cap Bolt M3x18	4	5	
	157	Silicone Grease	1	2 4 29	
	158	Screw Locking Compound	2		
	OPM-3	2	Wheel	4	15
	OPM-4	8	Spur Gear Shaft	1	2
9		2 φ x11 Pin	1	2	
18		Center Gear Shaft	1	2	

BAG	NO.	PARTS NAME	Q'TY	Step	
OPM-4	24	Gear Protector Plate (B)	1	2	
	25	Gear Protector Washer	2	2	
	29	Gear Protector Collar	1	2	
	41	Saver Shaft	2	11	
	52	King Pin	4	11	
	61	5,8 φ Ball (Black)	4	13 14	
	92	Ball Nut	4	17 18	
	154	Heatsink Collar	1	30	
	OPM-5	21	Rear Plate (L)	1	8
		22	Rear Plate (R)	1	8
27		Gear Protector Plate (A)	1	2	
30		Upper Rod Plate	1	2	
31		Rear Shock Stay	1	15	
34		Front Shock Stay	1	15	
35		Front Suspension Plate	1	15	
71		Rear Suspension Plate	1	15	
127		Motor Plate	1	29	
OPM-6		13	Pulley (Yellow)	1	2
	14	Pulley Flange (Yellow)	1	2	
	15	5 φ Collar (S) (Yellow)	2	2	
	23	5 φ Collar (L) (Yellow)	1	2	
	37	Bumper	1	15	
	43	Upper Deck Mount	1	11	
	44	Rear Suspension Pivot	1	9	
	45	Battery Holder	2	10	
	50	Front Hub (R)	1	11	
	51	Front Hub (L)	1	11	
	56	Front Stabilizer End	2	12	
	65	Rear Hub (R)	1	12	
	66	Rear Hub (L)	1	12	
	90	Shock Bushing	4	22	
	93	Servo Saver (A)	1	17	
	94	Servo Saver (B)	1	17	
	95	Servo Saver (C)	1	17	
	96	Servo Saver (D)	1	17	
	97	Servo Saver Collar	2	18	
	100	Servo Stay	4	20 21	
	101	Servo Stay Spacer	2	20	
	103	Switch Plate	1	22	
	119	Servo Spacer	2	11	
	131	Antenna Post	1	25	
	134	Wing Stay A (L)	1	13	
	135	Wing Stay A (R)	1	13	
	136	Wing Stay B	2	13	
	137	Wing Stay Joint	2	13	
138	Wing Washer	4	10		

## "OPTIMA MID" BAGGED PARTS LIST (2)

BAG	NO.	PARTS NAME	Q'TY	Step
OPM-6	155	M3 Plastic Nut	4	22
OPM-7	49	M2,6 Pillow Ball (Black)	4	11 17
	53	5.8 φ Ball (Silver)	4	18 18
	55	M3 Pillow Ball (Silver)	4	17 17
	58	Suspension Shaft (A)	2	17
	59	Suspension Shaft (B) (silver)	2	17
	63	Ball End (L)	12	18 18 17
	64	Upper Rod	4	18 18
	69	Suspension Shaft (C) (Black)	2	17
	70	Suspension Shaft (D)	2	15
	91	Ball End (S)	2	17
98	Tie Rod	2	18	
OPM-8	36	Chassis	1	7
	38	Belt Cover (A)	1	14
	39	One Touch Tape	2	13
	102	Upper Deck	1	9
	104	Belt Cover (B)	1	26
	107	Belt Cover (C)	1	26
	115	Motor Cord	2	20
	125	Motor Cover	1	20
	126	Motor Cleaner	1	24
	129	Gear Cover	1	29
	132	Antenna Pipe	1	33
	144	Ni-Cad Strap	2	30
	OPM-9	40	Sponge Tape	2
91		Ball End (S)	2	24
99		Steering Rod	1	24
106		Rubber Cover	1	22
110		Speed Control Horn	1	30
111		Speed Control Pivot	1	30
112		Speed Contro Stud	1	30
113		Speed Control Spring	1	30
114		Speed Control Contact	2	30
117		Regulator	1	26
118		BEC Connector	1	30
120		Speed Control Rod	1	17
121		Resistor	1	30
130		Both Side Tape	1	13
133		Strap (S)	3	17 18
156		Speed Control PC Board	1	30 ( 32 )
		Motor Condencer	1	24
Others	1	Tire	4	35
	141	Body	1	37
	142	Wing	1	37
	143	Decal	1	38
		Instruction	1	

BAG	PARTS NAME	Q'TY
OPM-1	M2,6x4 Bind Screw	4
	M2,6x6 Bind Screw	7
	M2,6x12 Bind Screw	4
	M3x6 Bind Screw	9
	M3x10 Bind Screw	4
	M3x30 Bind Screw	2
	M3x35 Bind Screw	1
	M3x45 Bind Screw	2
	M4x12 Bind Screw	2
	M3x4 Screw	2
	M3x12 Flat Head Screw	2
	M2,6x6 TP Bind Screw	3
	M2,6x12 TP Bind Screw	4
	M3x6 TP Bind Screw	7
	M3x10 TP Bind Screw	28
	M3x15 TP Bind Screw	3
	M3x18 TP Screw	4
	M3x6 TP Flat Head Screw	1
	M3x10 TP Flat Head Screw	2
	M2,6 NUt	14
	M3 NUt	6
	M3 Nut (Gold)	2
	109 Speed Control Nut	1
	M3 Nylon Nut	1
	M4 Nylon Nut	4
	M2,6 Washer	8
	M3 Washer	4
	M4 Washer	2
	M5 Washer	4
	5 φ Shim	8
	28 Wave Washer	3
	M3x3 Set Screw	1
	M4x4 Set Screw	4
	60 E Ring (E-2,5)	13
	57 E Ring (E-3) (Black)	3
	11 E Ring (E-4)	5
	45 Wing Pin (S)	2
	46 Body Pin (L)	2
	107 M2 Shaft	2
	108 Allen Wrench (1,5 mm)	1
	5 Allen Wrench (2,0 mm)	1
	62 Allen Wrench (2,5 mm)	1

# "OPTIMA MID" SMALL PARTS USED IN EACH ASSEMBLY STEP

④ Allen Wrench (2.5 mm).....1

⑤ Allen Wrench (2 mm).....1

⑥ Allen Wrench (1.5 mm).....1

## 1 INSTALLATION OF JOINT

M4x4 Set Screw.....4

5 Washer.....4

③ 8 φ x14 Ball Bearing ..4

④ Joint.....4

## 2 ASSEMBLY OF REAR GEAR BOX

M3x18 TP Screw ..2

M4 Washer.....2

⑦ 5 φ x10 Ball Bearing ..2

⑧ Spur Gear Shaft..1

⑨ 2 φ x11 Pin.....1

⑩ Counter Gear.....1

⑪ E Ring (E-4).....2

⑫ 5 φ x8 Ball Bearing ..2

⑬ Pulley (A) (Yellow).....1

⑭ Pulley Flange (A) (Yellow).....1

⑮ 5 φ Collar (S).....1 (Yellow)

⑯ 4 φ x8 Ball Bearing ..2

⑰ Center Gear Shaft.....1

## 3 INSTALLATION OF REAR PLATE

M3x35 Bind Screw..1

M3x45 Bind Screw...2

## 4 INSTALLATION OF SPUR GEAR

M3x10 TP Bind Screw ..2

M3 Nylon Nut.....1

⑲ 5 φ Collar (L).....1 (Yellow)

⑳ Wave Washer.....3

㉑ Limmiter Collar.....1

㉒ 5 φ Shim.....2

Use when excessive plays.

## 5 INSTALLATION OF REAR SHOCK STAY

M3x10 TP Bind Screw.....2

M3x18 Cap Bolt.....2

M3 Nut.....2

## 6 ASSEMBLY OF FRONT GEAR BOX

M3x6 TP Bind Screw ..2

M3x10 TP Bind Screw.....4

M3x18 Cap Bolt.....2

M3x18 TP Screw.....2

M3 Nut.....2

## 7 INSTALLATION OF GEAR BOX

M3x10 TP Bind Screw.....5

M3x15 TP Bind Screw.....1

## 8 INSTALLATION OF UPPER DECK MOUNT

3x6 Bind Screw.....4

M3x10 TP Bind Screw.....4

⑳ Saver Shaft.....2

㉓ Upper Deck Post..2

## 10 INSTALLATION OF BATTERY HOLDER

M3x6 TP Bind Screw.....4

M3x10 TP Bind Screw.....1

M3x10 TP Flat Head Screw.....2

## 11 ASSEMBLY OF KNUCKLE ARM

M2.6 Nut.....2

㉔ 5 φ x10 Ball Bearing ..4

㉕ Front Shaft.....2

㉖ M2.6 Pillow Ball...2 (Black)

㉗ King Pin.....4

## 12 INSTALLATION OF FRONT SUSPENSION ARM

㉘ M3 Pillow Ball...2 (Silver)

㉙ Front Stabilizer...2 End

㉚ E Ring (E-3).....2 (Black)

㉛ Suspension Shaft (A).....2

㉜ Suspension Shaft..2 (B) (Silver)

㉝ E Ring (E-2.5).....6

## 13 INSTALLATION OF FRONT UPPER ROD

M2.6x12 Bind Screw.....2

M3x12 Flat Head Screw.....2

M3x15 TP Bind Screw.....2

M2.6 Nut.....4

㉞ 5.8 Ball (Silver).....2

㉟ 5.8 Ball (Black).....2

㊱ Ball End (L).....4

㊲ Upper Rod.....2

## 14 INSTALLATION OF REAR HUB

㊳ 5 φ x10 Ball Bearing ..4

㊴ M3 Pillow Ball...2 (Silver)

㊵ E Ring (E-2.5).....2

㊶ Rear Shaft.....2

㊷ Suspension Shaft (C) (Black).....2

## 15 INSTALLATION OF REAR SUSPENSION ARM

M3x10 TP Bind Screw.....2

㊸ E Ring (E-2.5).....4

㊹ Suspension Shaft..2 (D)

# "OPTIMA MID" SMALL PARTS USED IN EACH ASSEMBLY STEP

## 16 INSTALLATION OF REAR UPPER ROD

- M2,6x12 Bind Screw \* 2
- M3x10 Bind Screw \* 2
- M2,6 Nut ..... 4
- 5.8 Ball (Silver) \* 2
- 5.8 Ball (Black) \* 2
- Ball End (L) ..... 4
- Upper Rod ..... 2

## 17 ASSEMBLY OF SERVO SAVER

- M2,6x6 Bind Screw \* 1
- M2,6 Washer ..... 4
- M2,6 Pillow Ball \* 2
- Ball End (S) ..... 2
- Ball Nut ..... 3
- M2 Shaft ..... 1

## 18 INSTALLATION OF SERVO SAVER

- E Ring (E-4) \* 2
- Ball End (L) ..... 4
- Servo Saver Collar ..... 2
- Tie Rod ..... 2
- 5 φ Shim ..... 2

## 19 ASSEMBLY OF OIL SHOCK

- E Ring (E-2.5) \* 4
- Shock O Ring (Red) .. 8
- Shock Collar (White) .. 4
- Plastic Washer (Black) .. 4
- C Ring ..... 4
- Shock Piston (Front) .. 2
- Shock Piston (Rear) .. 2

## 20 FILLING OF SHOCK OIL

- Shock Top ..... 4

## 22 INSTALLATION OF SHOCK

- Shock Bushing ..... 4
- M3 Plastic Nut ..... 4

## 24 INSTALLATION OF STEERING ROD

- M3x10 TP Bind Screw ..... 2
- M3 Washer ..... 2
- Ball End (S) ..... 1
- Steering Rod ..... 1
- Servo Stay ..... 2

## 25 INSTALLATION OF STEERING TIE ROD

- M2,6x6 TP Bind Screw ..... 1
- M3x10 TP Bind Screw ..... 2
- Servo Stay Spacer ..... 2
- Antenna Post ..... 1

## 27 INSTALLATION OF UPPER DECK

- M2,6x6 TP Bind Screw ..... 2
- M3x6 TP Bind Screw ..... 1
- M3x6 Bind Screw ..... 2
- M3x6 TP Flat Head Screw ..... 1
- M4x12 Bind Screw ..... 2

## 28 INSTALLATION OF BELT COVER (B) (C)

- M2,6x4 Bind Screw .. 4
- M2,6x6 Bind Screw .. 4
- M2,6 Washer ..... 4

## 29 INSTALLATION OF MOTOR

- M3x4 Screw ..... 2
- M3x10 Bind Screw .. 2
- M3x3 Set Screw ..... 1

## 30 ASSEMBLY OF SPEED CONTROLLER

- M2,6x6 Bind Screw .. 2
- M3x6 Bind Screw ..... 3
- M3 Nut ..... 2

- M3 Nut (Gold) ..... 2
- Ball Nut ..... 1
- Speed Control Nut ..... 1
- Speed Control Pivot ..... 1
- Speed Control stud ..... 1
- Speed Control Spring ..... 1
- Speed Control Contact ..... 1
- Heatsink Collar ..... 1

## 31 INSTALLATION OF SPEED CONTROL SERVO

- M3x10 TP Bind Screw ..... 4
- M3 Washer ..... 2
- Servo Stay ..... 2
- Servo Spacer ..... 2

## 32 SPEED CONTROL LINKAGE

- Ball End (S) ..... 1
- Speed Control Rod ..... 1

## 34 INSTALLATION OF WING STAY

- M2,6x12 TP Bind Screw ..... 4
- M3x30 Bind Screw ..... 2

## 36 INSTALLATION OF TIRE

- M4 Nylon Nut ..... 4
- Drive Washer ..... 4
- 5 φ Shim ..... 4

## 40 INSTALLATION OF BODY AND WING

- Wing Washer ..... 2
- Wing Pin ..... 2
- Body Pin ..... 2

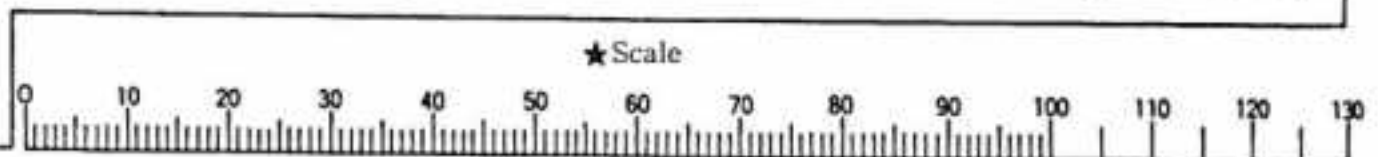

# PURCHASING PARTS FOR YOUR KIT

You can purchase replacement and optional parts for your kit. All of the part identified by key numbers (see page 21 for a complete list) are usually not available singularly, but we offer these parts in convenient parts "packs" which can be purchased separately.

To figure out which parts pack you need, find the key number for that part within the manual. Then consult our parts pack guide, below. When referring to the parts you need, always use the parts pack number. For instance, if you need a King Pin (Key No.52) ask your dealer for Kyosho Parts Pack OT-4 (King Pin).

**OT-4 KING PIN**

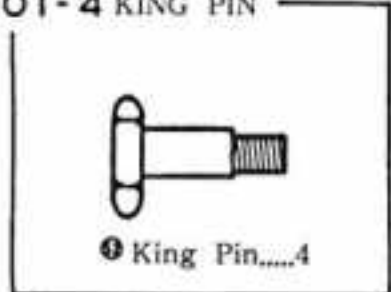

**OT-5 JOINT**

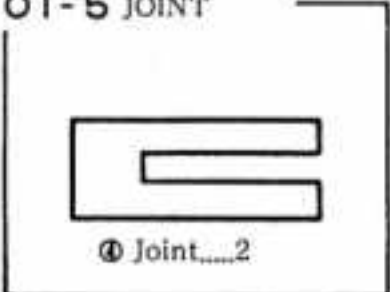

**OT-6 SWING SHAFT**

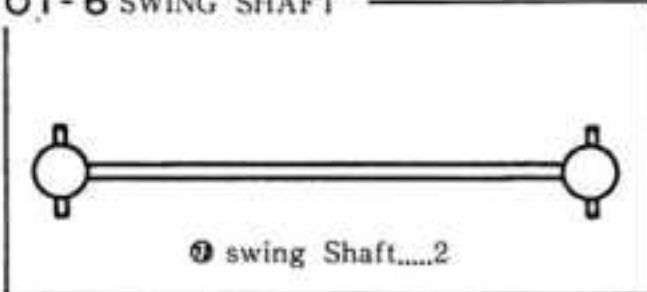

**OT-16 KNUCKLE ARM**

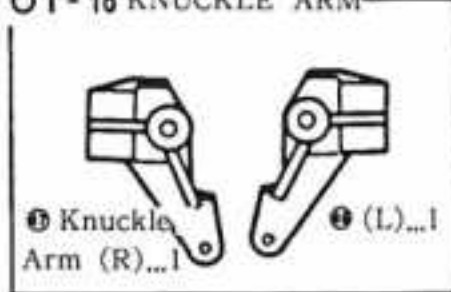

**OT-17 FRONT SHAFT**

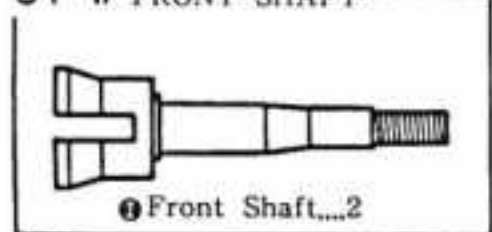

**OT-18 REAR SHAFT**

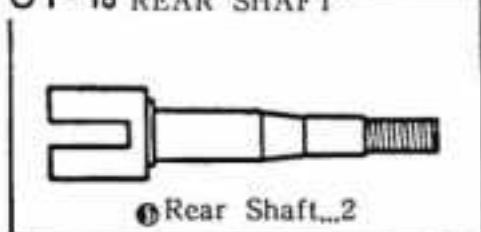

**OT-19 DRIVE WASHER**



**OT-28 DIFFERENTIAL GEAR SET**

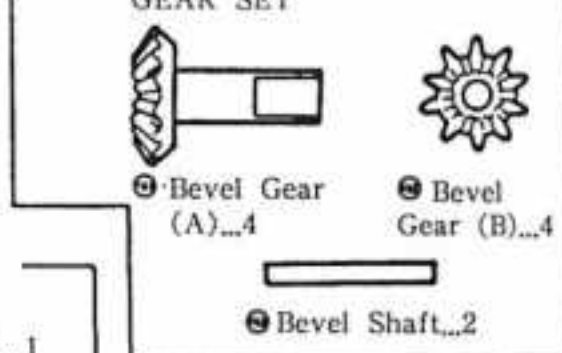

**OT-31 M3 PILLOW BALL**



**OT-32 5.8 φ BALL**

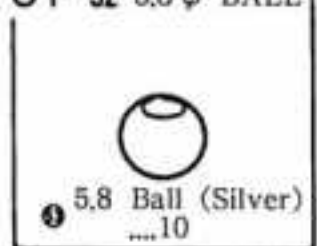

**OT-33 BALL NUT (M2,6)**



**OT-35 UPPER ROD SET**

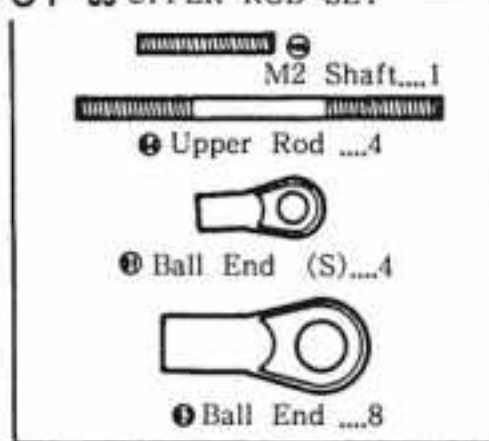

**OT-36 M2,6 PILLOW BALL**



**OT-37 CORD SET**

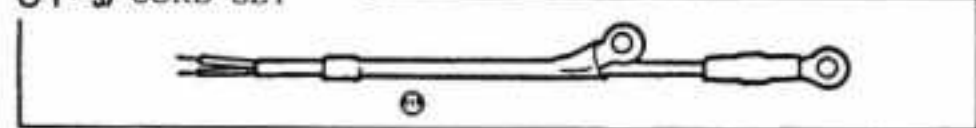

**OT-38 SILICONE GREASE**

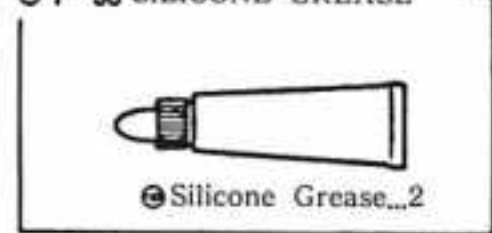

**OT-39 E RING (2.5)**



**OT-45 REAR HUB**

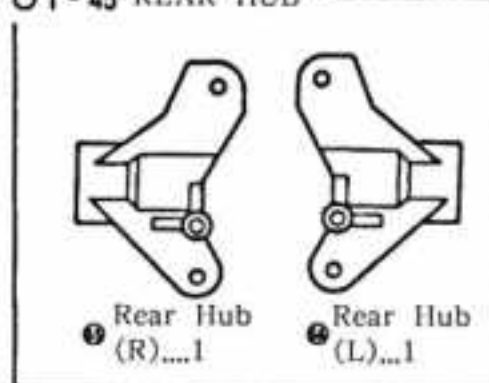

**OT-55 FRONT HUB**

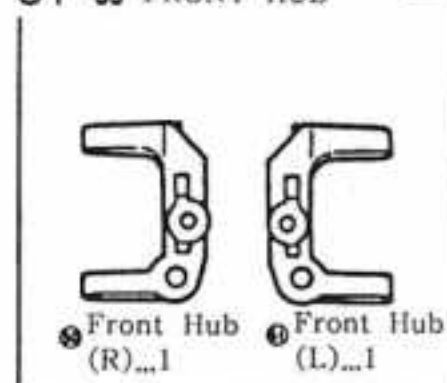

**OT-66 LOW PROFILE TIRE (PIN TYPE)**

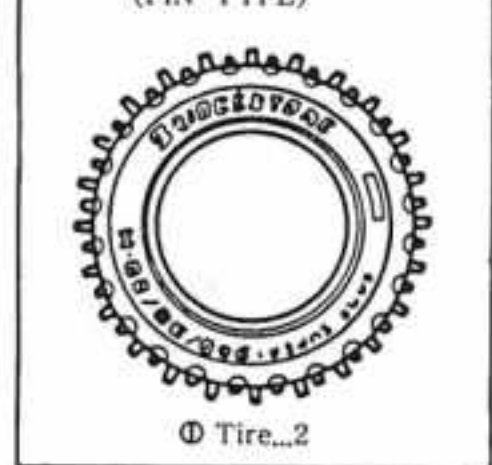

**OT-69 SUSPENSION ARM SET**

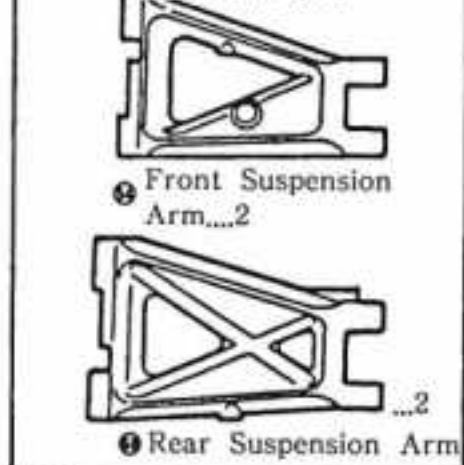

**OT-72 HEATSINK FOR RESISTOR**

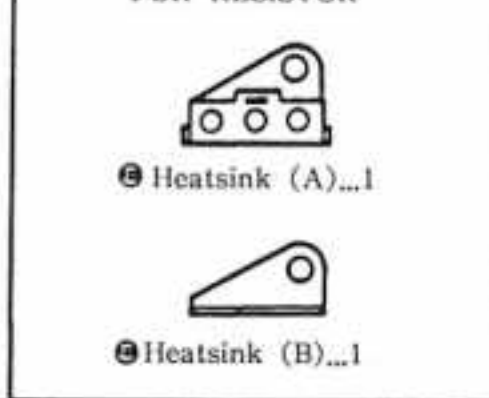

**OT-73 MOTOR CLEANER**

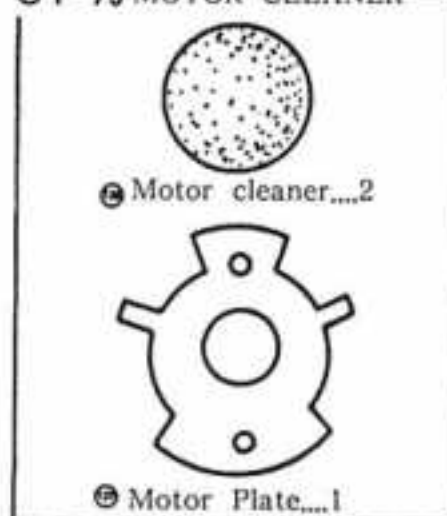

**OT-84 GEAR BOX**

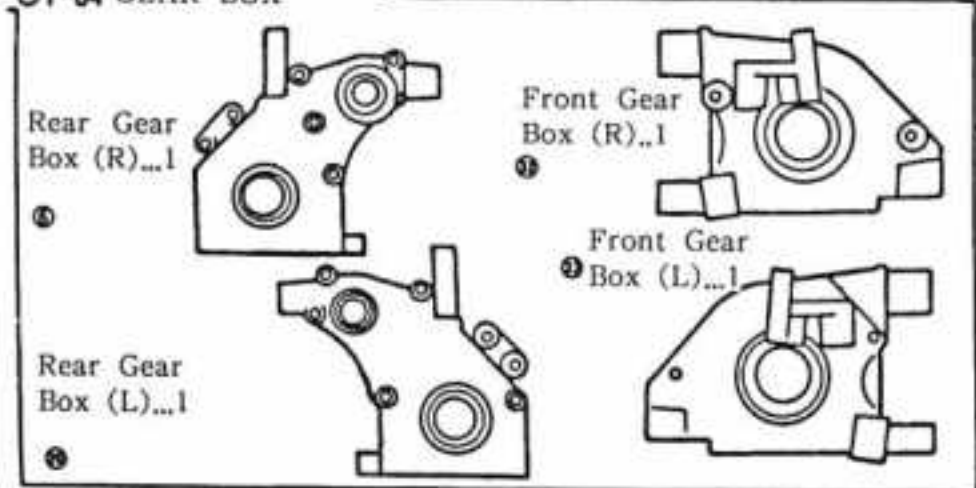

**OT-85 SPUR GEAR**

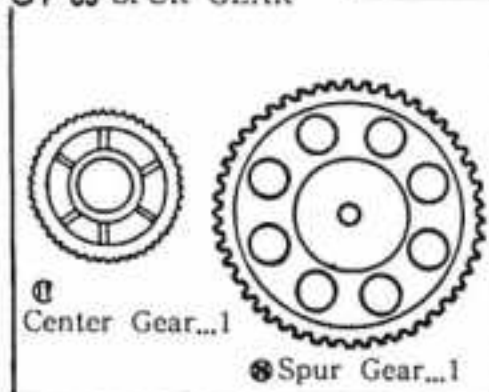

**OT-86 COUNTER GEAR**



OT-87 GEAR SHAFT SET

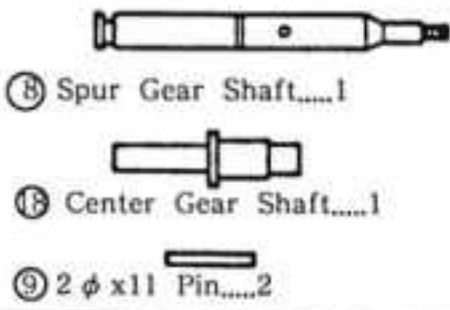

OT-88 PROTECTOR SET

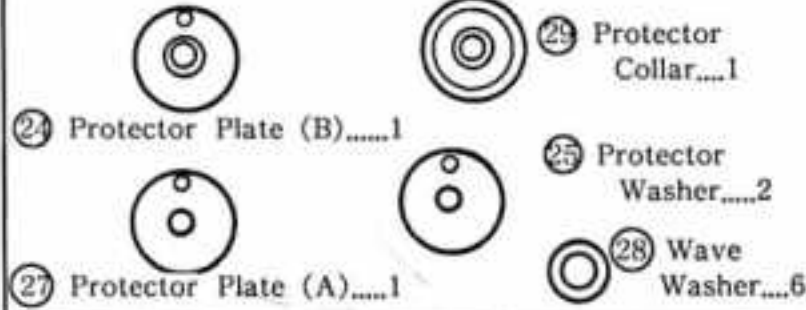

OT-89 TOOTHED BELT

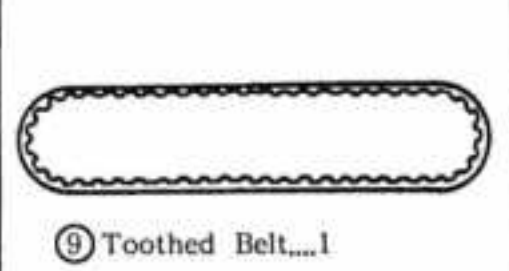

OT-90 WHEEL



OT-91 CHASSIS

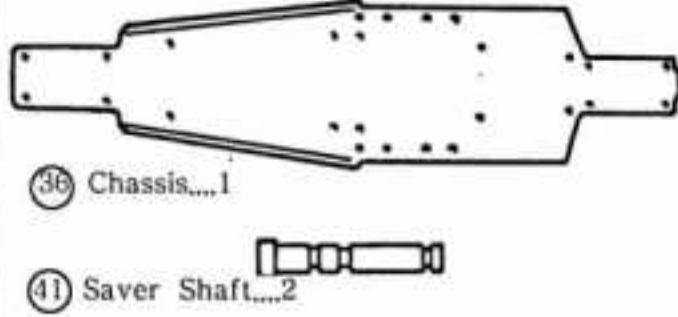

OT-92 UPPER DECK

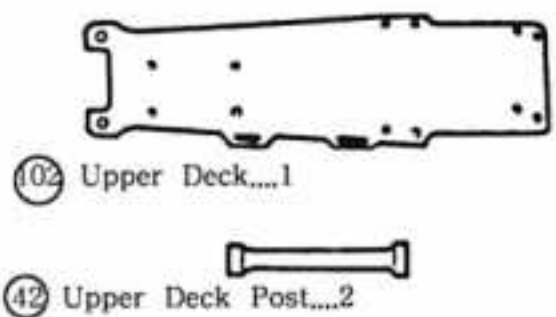

OT-93 BUMPER

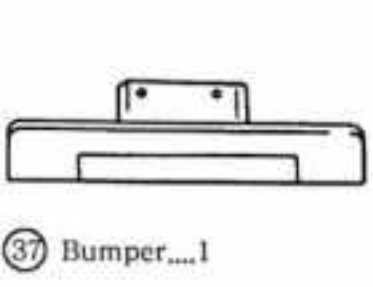

OT-94 SHOCK STAY

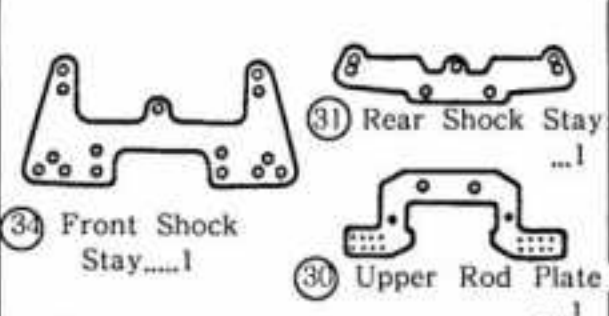

OT-95 PLATE SET

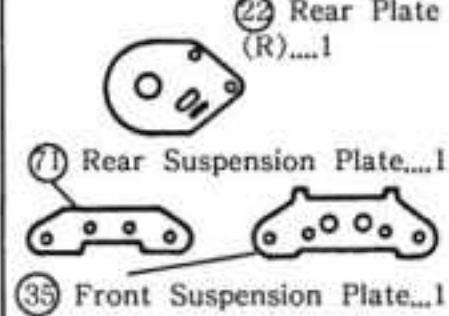

OT-96 REAR PLATE

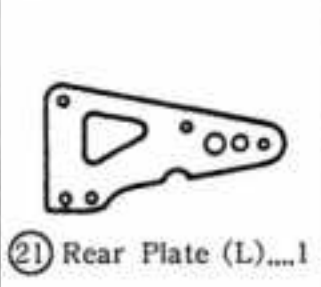

OT-97 SUSPENSION SHAFT SET

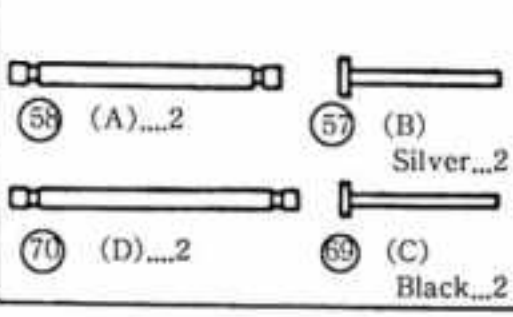

OT-98 BATTERY HOLDER SET

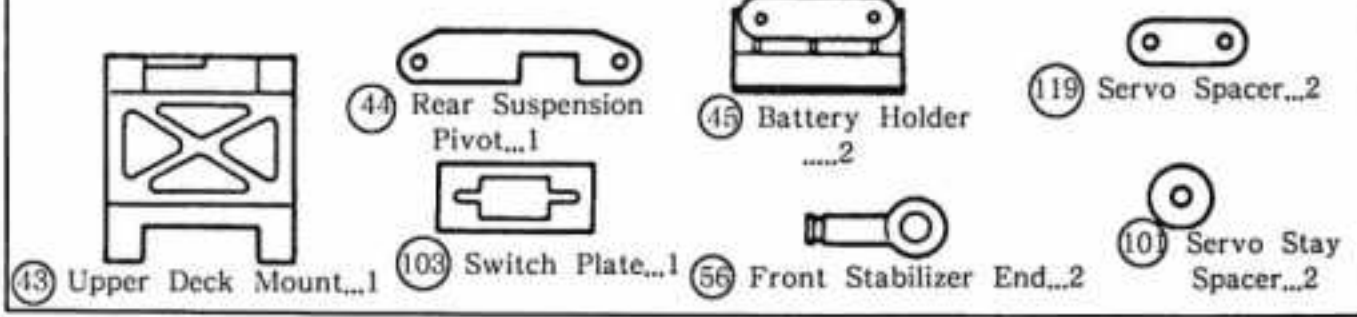

OT-99 WING STAY SET

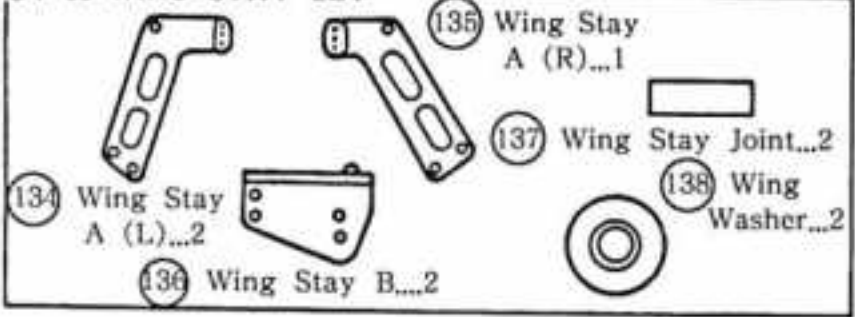

OT-100 COLLAR SET

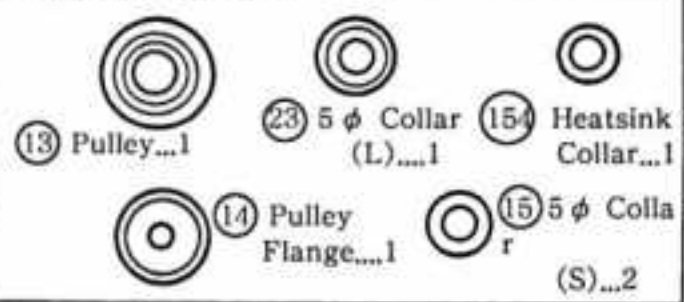

OT-101 5.8 φ BALL (BLACK)

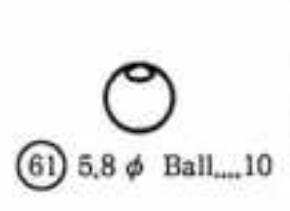

OT-102 BELT COVER SET

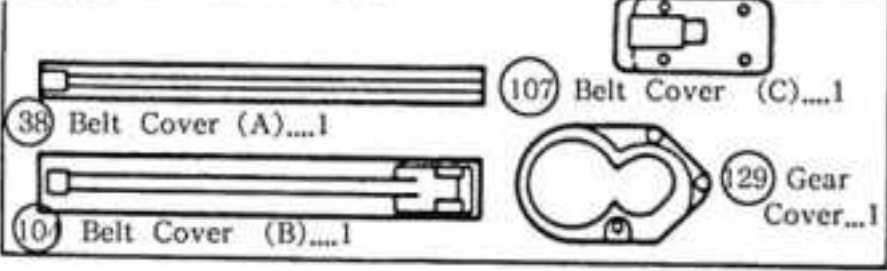

OT-103 TAPE SET

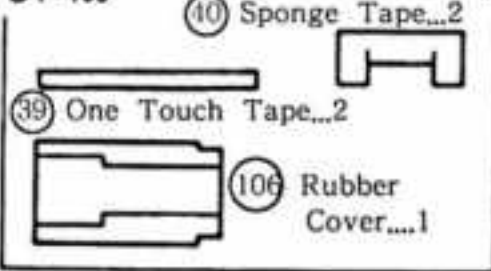

OT-104 MOTOR CORD

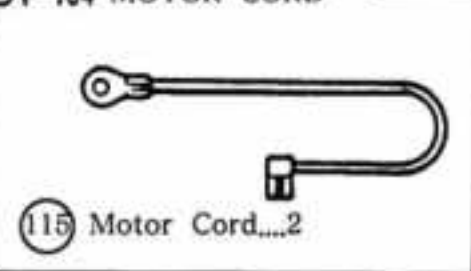

OT-105 ROD SET

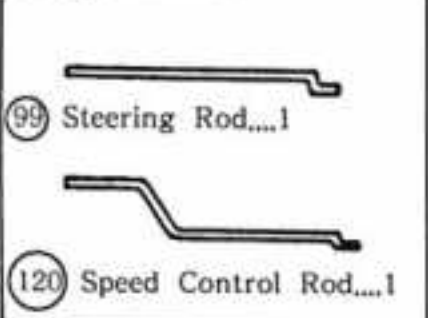

OT-106 BODY SET

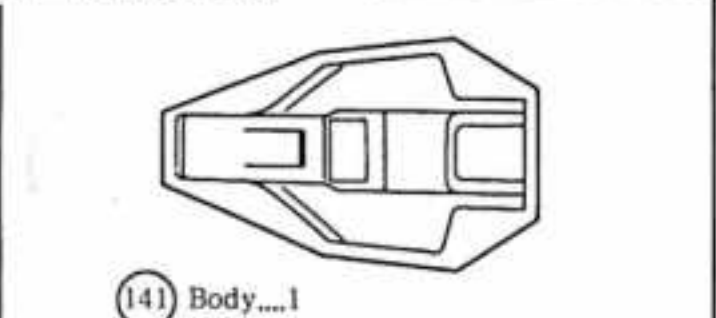

OT-107 WING

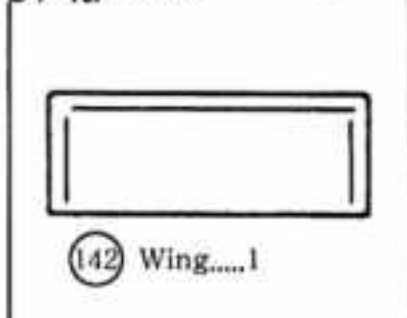

OT-108 DECAL

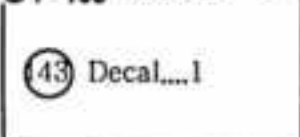

OT-109 SCREWSET

1 Set

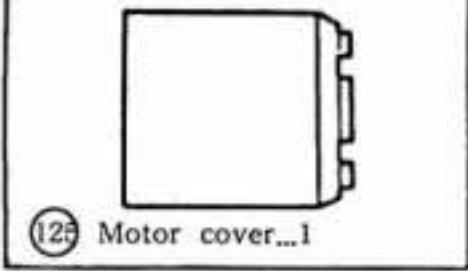
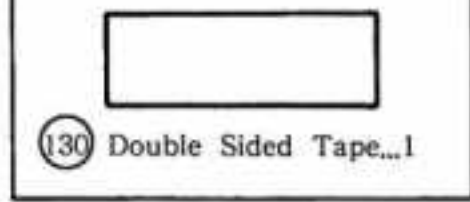
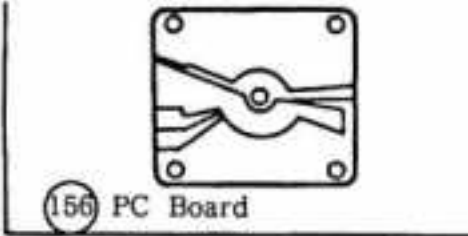
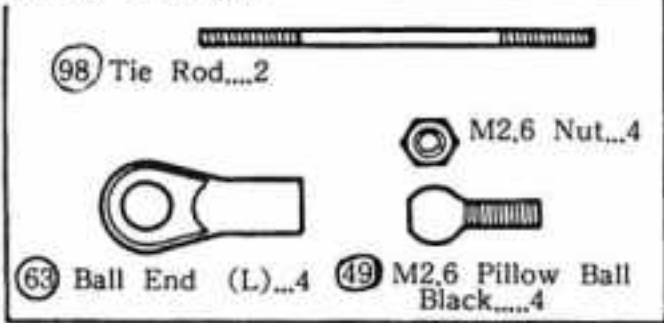
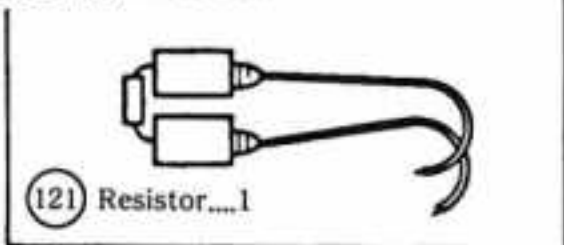
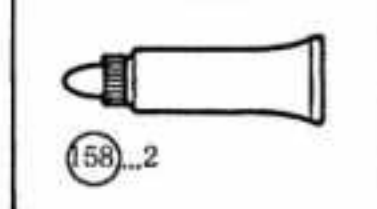
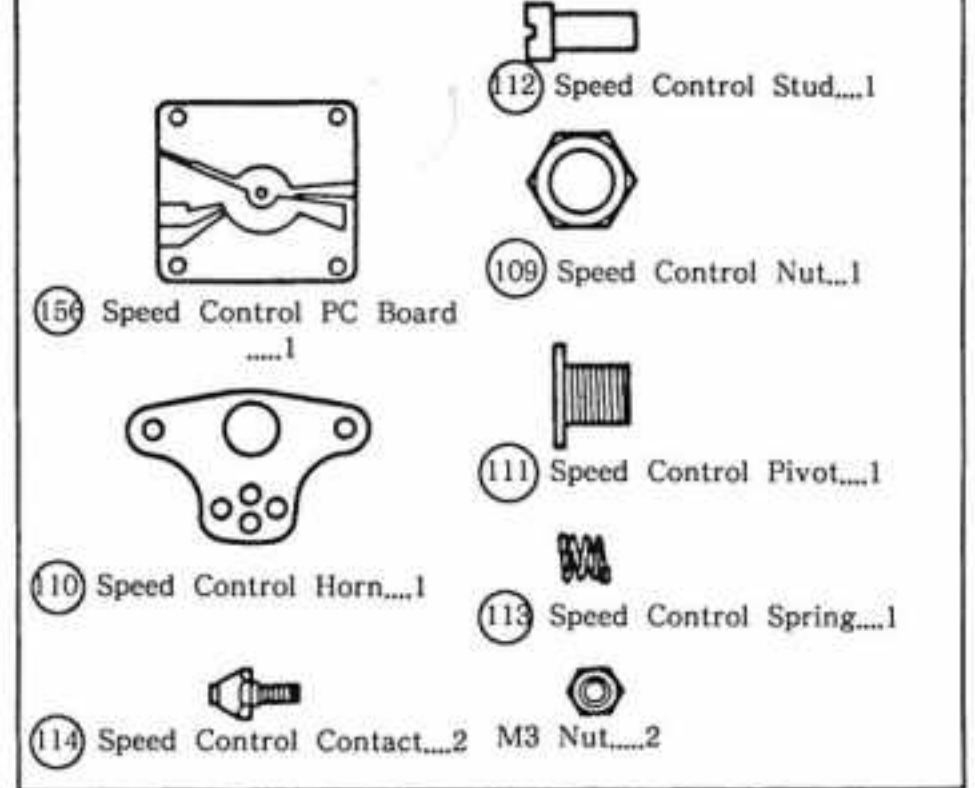
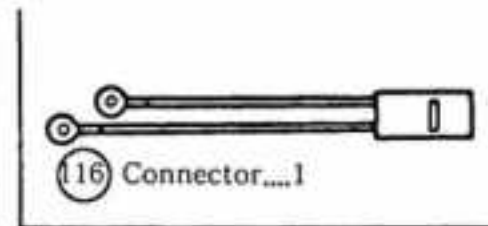
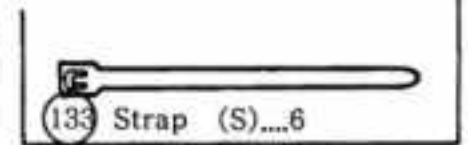
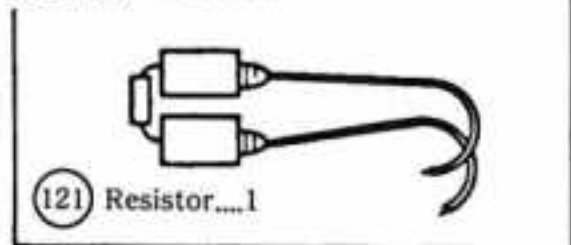
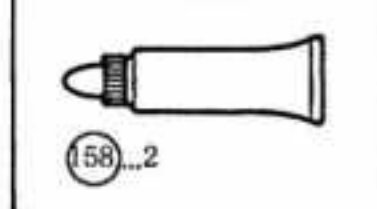
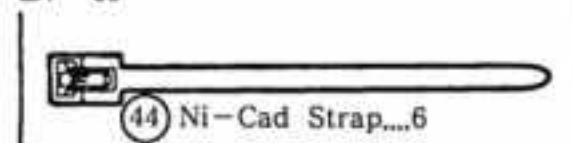
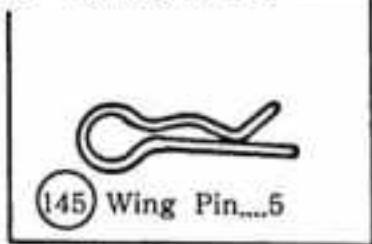
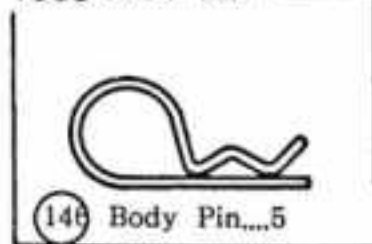
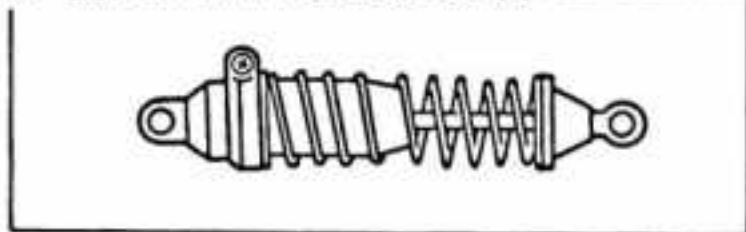
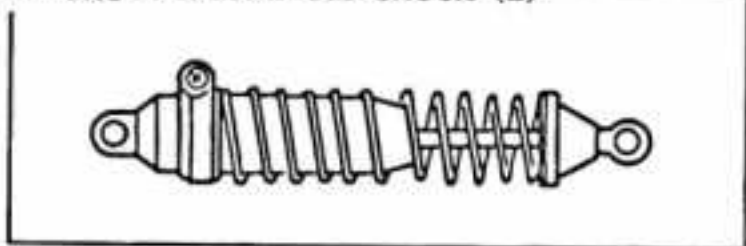
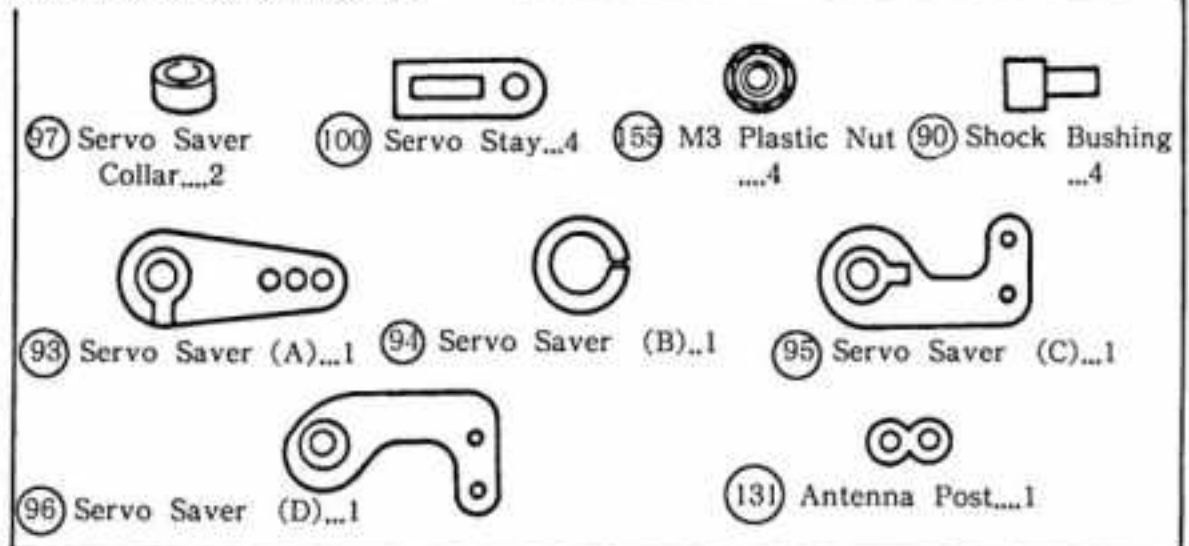
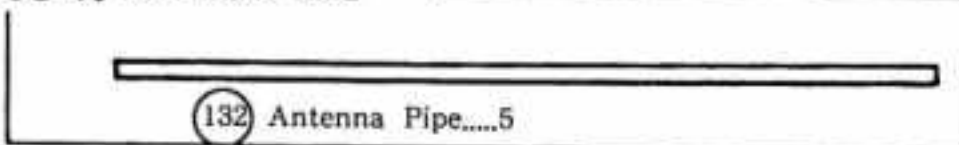
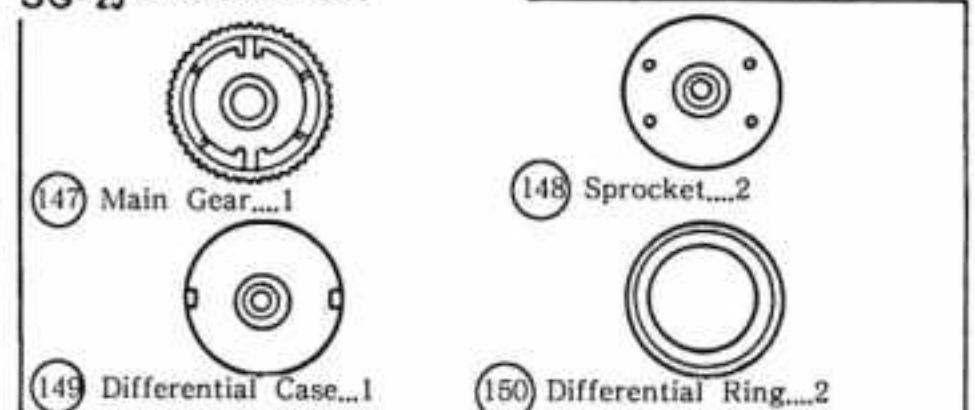
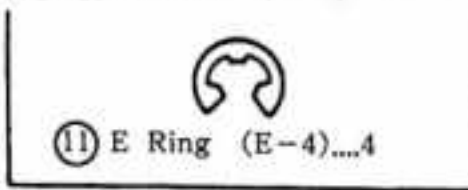
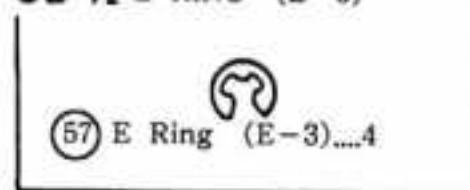
**SC-40 MOTOR COVER****1840 DOUBLE SIDED TAPE****SPEED CONTROL SC-78 PC BOARD****SC-79 SPEED CONTROL CONTACT POINT****SC-89 TIE ROD****SC-105 RESISTOR****1878 SCREW LOCKING COMPOUND****SC-67 SPEED CONTROLLER****EF-26E CONNECTOR****EF-37 STRAP (s)****SC-105 RESISTOR****1878 SCREW LOCKING COMPOUND****EF-39 NI-CAD STRAP****1903 4 φ X8 BALL BEARING****EP-22 HOOK PIN****1889 BODY PIN****1911 8 φ X14 BALL BEARING****1901 5 φ X10 BALL BEARING****1902 5 φ X8 BALL BEARING****W-5001 PRESSURE OIL SHOCK (S)****W-5002 PRESSURE OIL SHOCK (L)****UM-14 SERVO SAVER SET****SD-79 ANTENNA PIPE****SG-25 SPROCKET SET****KC-20 E RING (E-4)****CB-72 E RING (E-3)**

# OPTIONAL PARTS LIST

## OT-64 SPECIAL WING

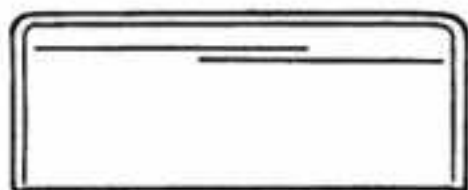

Special Wing (Silver)...1

## OT-67 LOW PROFILE WHEEL (White)

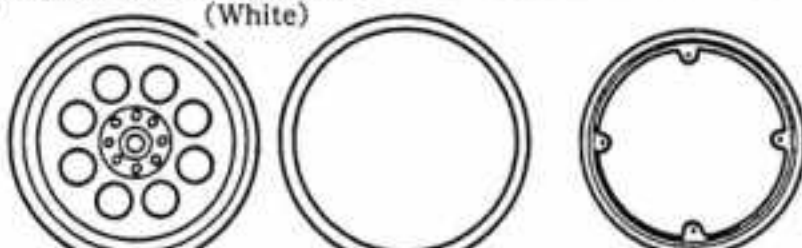

Wheel (1)...2

Wheel (2)...2

Wheel (3)...2

## 1863 SPONCER STICKER

Sponcer Sticker ...2

## OTW-3 SPECIAL CHASSIS

2.3mm Thickness

## OT-47 FRONT HUB SET (Low Caster)

Front Hub (R)...1      Front Hub (L)...1

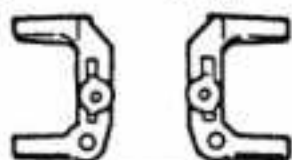

## HARD PINION GEAR



- W-5090(20T)
- W-5085(15T) W-5091(21T)
- W-5086(16T) W-5092(22T)
- W-5087(17T) W-5093(23T)
- W-5088(18T) W-5094(24T)
- W-5089(19T) W-5095(25T)

## LM-15 COOLING PLATE



Coolong Plate...1

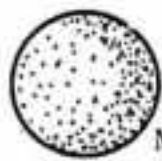

Sponge...1

M3x12 Cap Screw

## 1951 SHOCK OIL SET

(S.M.H)



## W-5005 SPECIAL ROD SET

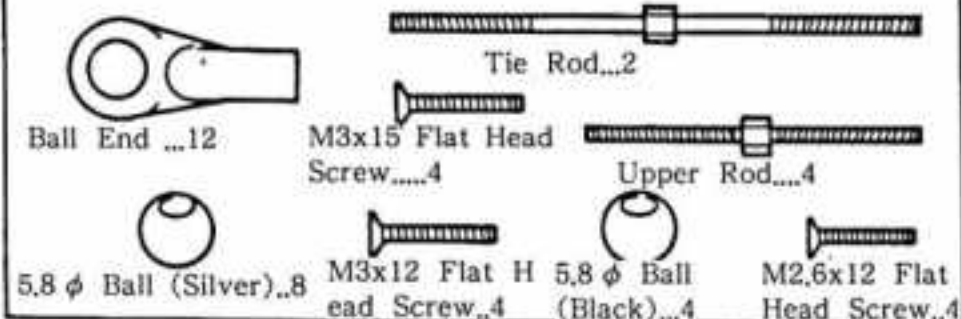

Tie Rod...2

Upper Rod...4

M3x15 Flat Head Screw...4

M3x12 Flat Head Screw...4

M2.6x12 Flat Head Screw...4

Ball End ...12

5.8 φ Ball (Silver)...8

5.8 φ Ball (Black)...4

## 1952 DIFFERENTIAL OIL



Differential Oil ...1

## 1953 SILICONE OIL (S)



Viscosity 100SC,200SC...1ea

## LOW PROFILE TIRE W-5031 (HARD)



Low Profile Tire...2

## 1954 SILICONE OIL (M)



Viscosity 300SC,400SC...1ea

## W-5003 ADJUSTABLE SHOCK (S)

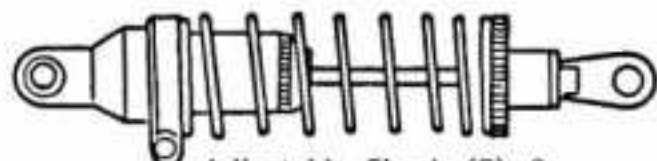

Adjustable Shock (S)...2

## 1955 SILICONE OIL (H)



Viscosity 500SC,600SC...1ea

## W-5004 ADJUSTABLE SHOCK (L)



Adjustable Shock (L)...2

## LOW PROFILE TIRE W-5032 (SOFT)



Low Profile Tire...2

## OTW-2 SPECIAL SHOCK STAY

Rear Shock Stay...1

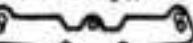

Front Shock Stay...1



Upper Rod Plate...1

## W-5061 UNIVERSAL SWING SHAFT

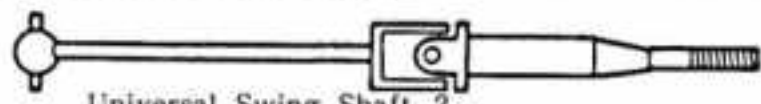

Universal Swing Shaft...2



5 φ x12 Washer...2



M3 Nut...2

## OTW-1 STABILIZER SET

(for Front and Rear)



Rear Stabilizer...1



Front Stabilizer...1

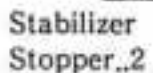

Stabilizer Stopper...2



4.8 φ Ball ...2



M3x3 Set Screw...2



Stabilizer Ring...2



Stabilizer End Ball...2



Stabilizer Pillow Ball...2



M2.6 Nut ...2

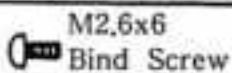

M2.6x6 Bind Screw

## UM-17 WHEEL SET (White)

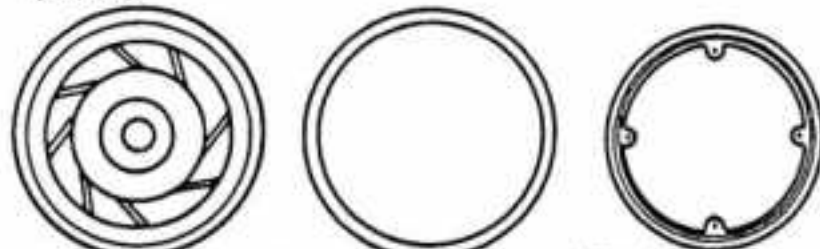

Wheel (1)...2

Wheel (2)...2

Wheel (3)...2

## LOW PROFILE WHEEL SET W-5021 (Silver Plated)

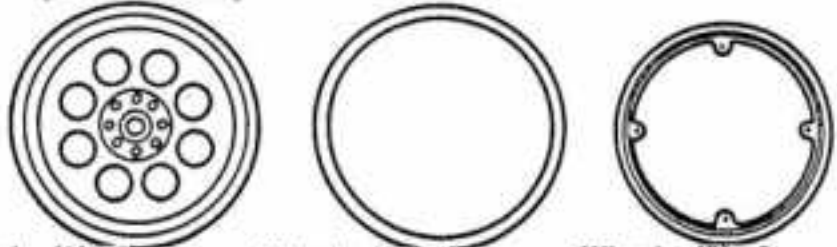

Wheel (1)...2

Wheel (2)...2

Wheel (3)...2

---

*The Super Hobby*



PRINTED IN JAPAN  
BF8M5T