

RADIO CONTROLLED ELECTRIC POWERED SPECIAL RACING BUGGY
4WD OFF-ROAD RACER
TURBO OPTIMA MID SE

- FOUR-WHEEL DRIVE BY LIGHTWEIGHT, EFFICIENT TOOTHED BELT.
- EXTRA-LONG SUSPENSION TRAVEL FOR TOP HANDLING.
- FOUR-WHEEL INDEPENDENT SUSPENSION BY WISHBONE/PARALLEL ARM.
- MID-SHIP MOTOR FOR OPTIMUM WEIGHT DISTRIBUTION AND QUICK REACTION.
- STRONG, LIGHT ALLOY ALUMINUM CHASSIS PLATE.
- ADJUSTABLE OIL-FILLED SHOCK ABSORBERS. ANTI-SWAY BARS FRONT AND REAR.
- POWERFUL LeMANS 240ST MOTOR INCLUDED.
- RELIABLE ROTARY SPEED CONTROLLER INCLUDED.
- MANY "OPTION HOUSE" CUSTOM PARTS INCLUDED.
- STRONG GLASS-REINFORCED NYLON SUSPENSION PARTS.
- LOW-PROFILE HIGH-GRIP SPIKE TIRES AND METALLIZED WHEELS.
- EASY ASSEMBLY AND ADJUSTMENT.

1:10 SCALE

BATTERY: 7.2V-1200mAh

RADIO: 2ch

[NOT INCLUDED]



KYOSHO®
THE FINEST RADIO CONTROL MODELS

KIT NO.3136H

BEFORE ASSEMBLY

*Be well aware of the different types of screws.

*Read the instruction carefully
You can assemble the kit more easily if you have grasped the general idea of steps and structure beforehand by reading it through to the end.



*Check the parts in the kit. Check to see if all the parts are correctly bagged as they are listed in the "List of Bagged Parts". Your thorough understanding of the assembly prior to starting will enable you to build the kit without difficulty.



Any claims for replacements or refunds for the model in the process of assembly will not, accepted without shortage or inferiority of the parts.

*Learn on the marks described in the instruction.

LOCKTITE ... Places to put some locktite. (It will prevent the screws and nuts get loosen by vibration while running.)

GREASE ... Should applied. (It will reduce friction to assure smooth movements.)



1. The difference between the TP screw (short form of self-tapping screw) and the ordinary screw is...

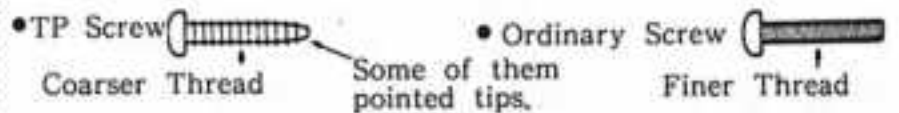

2. The kinds of screws which will be used in this instruction.

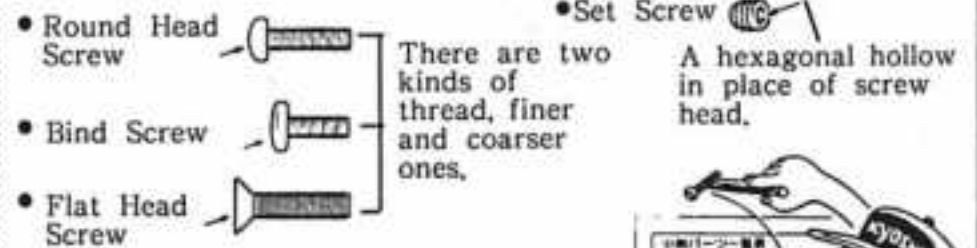

*Pick up the correct parts and screw. Compare the shape and size of small parts, such as screws, nuts, and washers with the attached sheet of "List of Small Parts".



*Be sure about the location and direction of parts to install.

Double-check the location and orientation of parts with the illustration before installation. When necessary, assemble the parts themselves tentatively before proceeding to the next step.



*Do not tighten the TP screw too strong. Do not use excessive force when tightening the TP screws, or you may strip the thread in the plastic. It is recommended to stop tightening it when the thread part on the screw goes into the plastic part and you feel some resistance from the tightening.

Over tighten may strip the thread in the plastic.

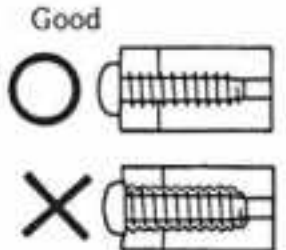

THINGS NEED BESIDES THE KIT
[2 Channel Radio System]



This model is designed for being controlled by a BEC type radio only. Get a radio with a mark as shown at left.

Two types of radio control set are on the market, the stick type and the steering wheel type. Choose which ever you like.

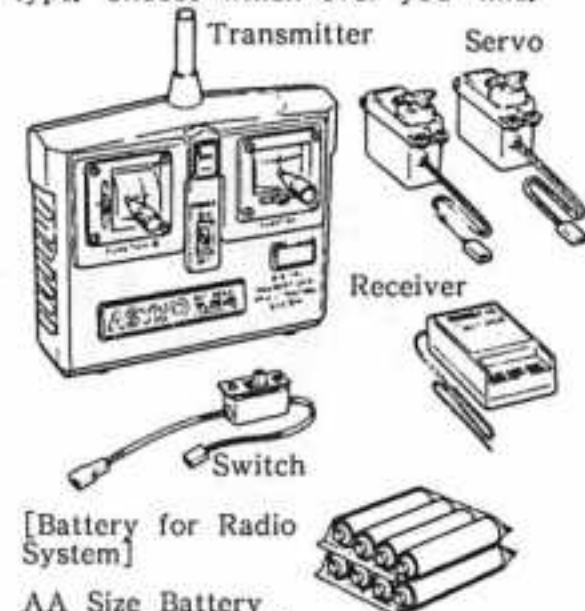

AA Size Battery For Transmitter...8 pcs.

[NiCd Battery]

"Turbo Optima Mid SE" is designed to use a rechargeable 7.2V NiCd battery pack. 7.2V Spring Battery and 7.2V Racing Battery are ideal for the purpose.

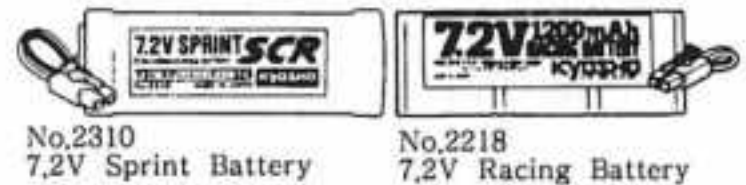

[Motor]

The Turbo Optima Mid SE not come with a motor. A Le Mans series type motor is recommended for top performance.

No.W1011 SPA 240WS
Le Mans
1926 Sports H-240S
1924 Le Mans 240SB



[Charger for NiCd Battery]

The Kyosho's NiCd battery is of high performance. If it is charged correctly, it will operate for a considerable period of time.

Use one of the Chargers listed below which suits your need

Model	Name	Time	Rate %	Features
No.2326	7.2V Power Quick Charger (DC12V)	15 (Min)	70%	For beginners Built-in timer
No.1845	Delta Peak Charger (12V)	20 (Min)	100%	Trickle Charging auto-cut off at peak charge.
No.1849	Multi Charger II	20 (Min)	100%	Chargable from Household Outlet, Built-in electric timer

[Required Tools] Hex key, Grease, CW cement are included with the kit.

Philips Screw Driver

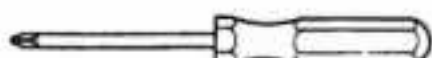

Box Driver (for M3 & M4 Nut)

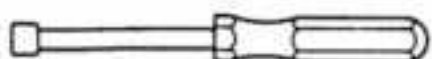

Sharp Hobby Knife



Needle Nose Plier

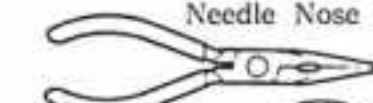

Round Cutter



Sander



Awl



Wire Cutter



Instant Glue



Polyca Paint



Brush



Micron Line Tape



"TURBO OPTIMA MID SE" PARTS LIST (1)

BAG	NO.	PARTS NAME	Q'TY	STEP
BLISTER A	1	Main Gear	1	3
	2	Center Gear	1	1
	3	Toothed Belt	1	1
	4	Main Gear Pinion	1	1
	5	Drive Washer	4	15
	6	Front Ball Diff.	1	5
	7	Rear Ball Diff.	1	1
	8	Front Adjustable Shock	2	10
	9	Rear Adjustable Shock	2	10
	10	Pinion Gear (20T)	1	28
BLISTER B	11	4 φ x 8 Ball Bearing	2	1
	12	5 φ x 8 Ball Bearing	2	1
	13	5 φ x 10 Ball Bearing	10	1 10 16
	14	Knuckle Arm (R)	1	10
	15	Knuckle Arm (L)	1	10
	16	Universal Swing Shaft	2	10
	17	Rear Wheel Shaft	2	18
	18	Le Mans 240ST Motor	1	21
	19	Rotary Speed Control	1	29
TSE-2	20	Front Gearbox (R)	1	5
	21	Front Gearbox (L)	1	5
	22	Rear Gearbox (R)	1	1
	23	Rear Gearbox (L)	1	1
	24	Shock Oil	1	10
	25	Shock Collar (Thickness 3mm & 5mm) each	4	20
	26	Spring Spacer (Thickness 3mm & 6mm) each	4	P.21
	27	Silicon Grease	1	
	28	Screw Locking Compound	1	
	29	Sponge Tape	2	3
	30	Rubber Cover	1	20
	31	One Touch Tape	2	7
	32	Strap (S)	2	17
	33	Condensor	1	21
TSE-3	34	Wheel	4	17
TSE-4	35	Saver Shaft	2	15
	36	Main Gear Shaft	1	1
	37	Gear Protector Plate (B)	1	3
	38	Gear Protector Collar	1	3
	39	Center Gear Shaft	1	1
	40	Gear Protector Washer	2	3
	41	King Pin	4	18
	42	5.8 φ Ball (Black Color)	4	12 15
	★43	2 φ x 11 Pin	2	1
	44	Heat Sink Collar	1	20
	45	Ball Nut	3	16
	46	Upper Deck Post	2	6
	47	Swing Shaft	2	15
	TSE-5	48	Rear Plate (R)	1
49		Rear Plate (L)	1	2
50		Front Shock Stay	1	5
51		Rear Shock Stay	1	6
52		Rear upper Plate	1	4
53		Rear Sus. Plate	1	17
54		Front Sus. Plate	1	5
55		Gear Protector Plate (A)	1	3
56		Motor Plate	1	25

BAG	NO.	PARTS NAME	Q'TY	STEP	
TSE-5	57	Heat Sink (A)	1	20	
	58	Heat Sink (B)	1	20	
TSE-6	59	Pully (Yellow)	1	1 Illustrated	
	60	Pully Flange (Yellow)	1	1 *	
	61	5 φ Collar (L) (Yellow)	1	3 *	
	62	5 φ Collar (S) (Yellow)	2	1 *	
	63	Battery Holder	2	12 *	
	64	Servo Spacer	2	10 *	
	65	Front Stabilizer End	2	11 *	
	66	Servo Stay Spacer	2	24 *	
	67	Switch Holder	1	24 *	
	68	Rear Sus. Pivot	1	13 *	
	69	Upper Deck Mount	1	13 *	
	70	Wing Stay (A) (R)	1	15 *	
	71	Wing Stay (A) (L)	1	15 *	
	72	Wing Stay (B)	2	15 *	
	73	Wing Stay Joint	2	15 *	
	74	Wing Washer	4	10 *	
	75	Bumper	1	12	
	76	Front Hub (R)	1	10	
	77	Front Hub (L)	1	10	
	78	Rear Hub (R)	1	15	
	79	Rear Hub (L)	1	15	
	80	Servo Saver (A)	1	16 Illustrated	
	81	Servo Saver (B)	1	16 *	
	82	Servo Saver (C)	1	16 *	
	83	Servo Saver (D)	1	16 *	
	84	Servo Saver Collar	2	17 *	
	85	Servo Stay	4	23 10 *	
	86	Antenna Post	1	21 *	
	TSE-7	87	Sus. Shaft (A) (Silver)	2	11
		88	Sus. Shaft (B) (Black)	2	11
		89	M3 Pillow Ball (Silver)	4	11 13
		90	M2.6 Pillow Ball (Black)	4	10 13
		91	5.8 φ Ball (Silver)	4	12 13
		92	Ball End (L)	12	12 13 13
93		Ball End (S)	4	13 20 11	
94		Suspension Shaft (C)	2	11	
95		Suspension Shaft (D)	2	13	
96		Steering Rod	1	20	
97		Speed Control Rod	1	11	
98		Tie Rod	2	13	
99		Upper Rod	4	12 13	
100		4.8 φ Ball	1	20	
TSE-8	100	4.8 φ Ball	2	11	
	101	Main Chassis	1	5	
	102	Upper Deck	1	20	
	103	Belt Cover (A)	1	7	
	104	Belt Cover (B)	1	25	
	105	Belt Cover (C)	1	25	
	106	Gear Cover	1	20	
	107	Double Sided Tape	1	12	
	108	Motor Cleaner	1	20	
	109	Motor Cover	1	20	
	110	Motor Cord (Red, White)	1set	20	
111	Front Suspension Arm	2	11		

"TURBO OPTIMA MID SE" PARTS LIST (2)

DRAWING OF PLASTIC PARTS PLACEMENT

BAG	NO.	PARTS NAME	Q'TY	STEP	
TSE-8	112	Rear Suspension Arm	2	18	
	113	Stabilizer Link	2	18 Illustrated	
	114	Stabilizer Stopper	2	4	
	115	Front Stabilizer	1	5	
	116	Rear Stabilizer	1	4	
	117	Stabilizer End Ball	2	4	
	118	Stabilizer Pillow Ball	2	18	
	119	Sponge Cap	2	1	
	120	Antenna Pipe	1	17	
	121	NiCd Strap	2	19	
	Others	122	Body	1	16
123		Wing	1	16	
124		Tire	4	14	
125		Decal	1	18	
		Instruction Manual	1		
TSE-1 Screw, Nuts & Others	126	5 φ Shim	8	6 7 18	
	★127	M2 Shaft	2	18	
	★128	E Ring (E2,5)	13	11 15 17	
	★129	E Ring (E3) (Black)	3	11	
	★130	E Ring (E4)	5	11 17	
	131	Wing Pin	2	11	
	132	Body Pin	2	11	
	133	Hex Key (1,5mm)	1	4 28	
	134	Hex Key (2mm)	1	1	
	135	Wave Washer	3	6	
		Blind Screw	M2.6×4	4	
		•	M2.6×6	7	
		•	M2.6×12	4	
		•	M3×6	3	
		•	M3×10	4	
		•	M3×18	4	
		•	M3×30	2	
		•	M3×35	1	
		•	M3×45	2	
		•	M4×12	2	
		Round Head Screw	M3×4	2	
		•	M3×10	2	
		Flat Head Screw	M3×6	4	
		•	M3×12	2	
		TP Blind Screw	M2.6×6	3	
		•	M2.6×12	4	
		•	M3×6	4	
		•	M3×10	3	
		TP Round Head Screw	M2×8	1	
		•	M3×18	4	
		TP Flat Head Screw	M3×6	5	
		•	M3×10	11	
		•	M3×15	3	
		Nut	M2.6 (3 types)	16	
		•	M3	6	
	Nylon Nut	M3	5		
	•	M4	4		
	Washer	2.6φ (Black)	8		
	•	3φ	4		
	•	4φ	2		
	Set Screw	M3×3	3		

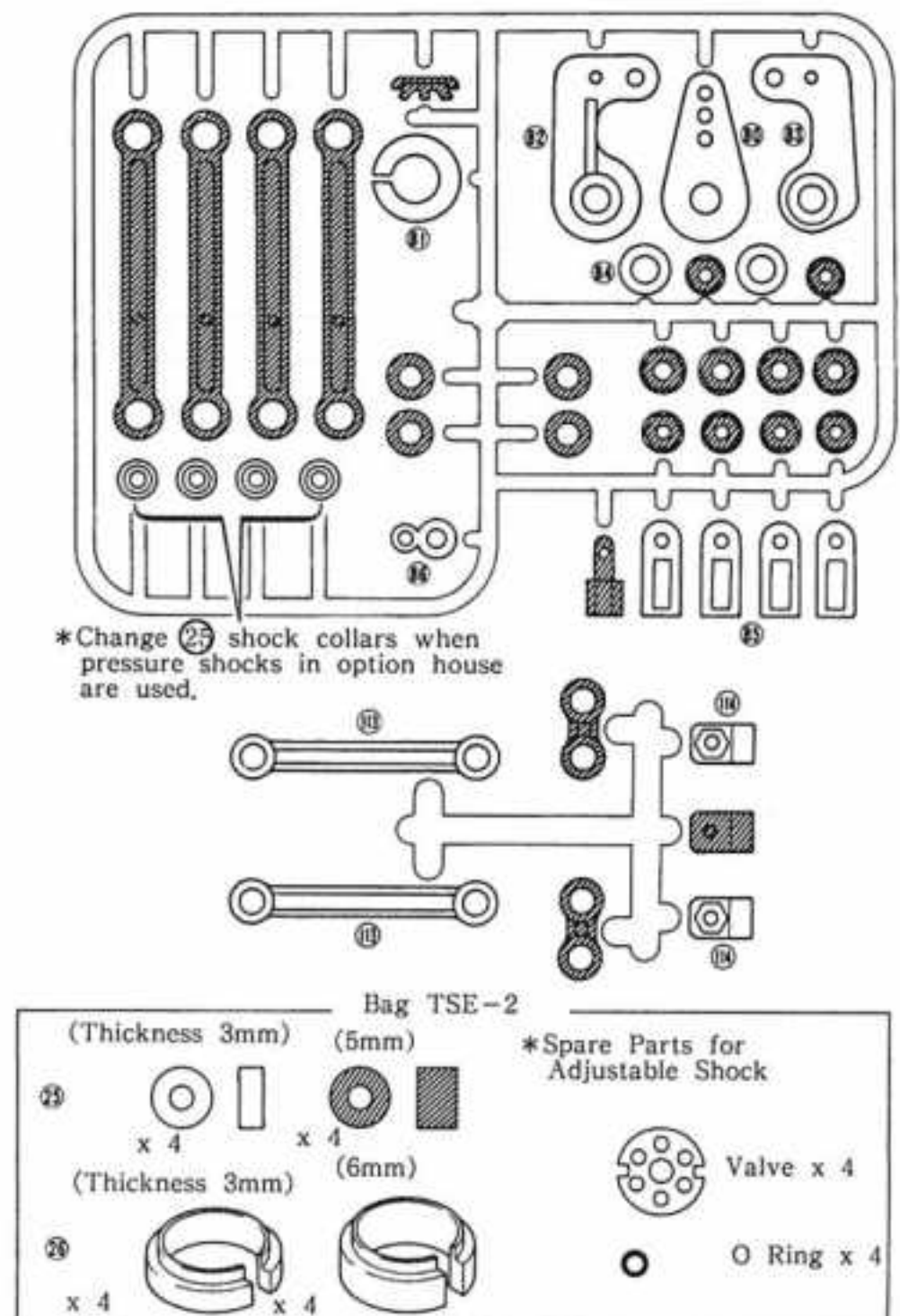
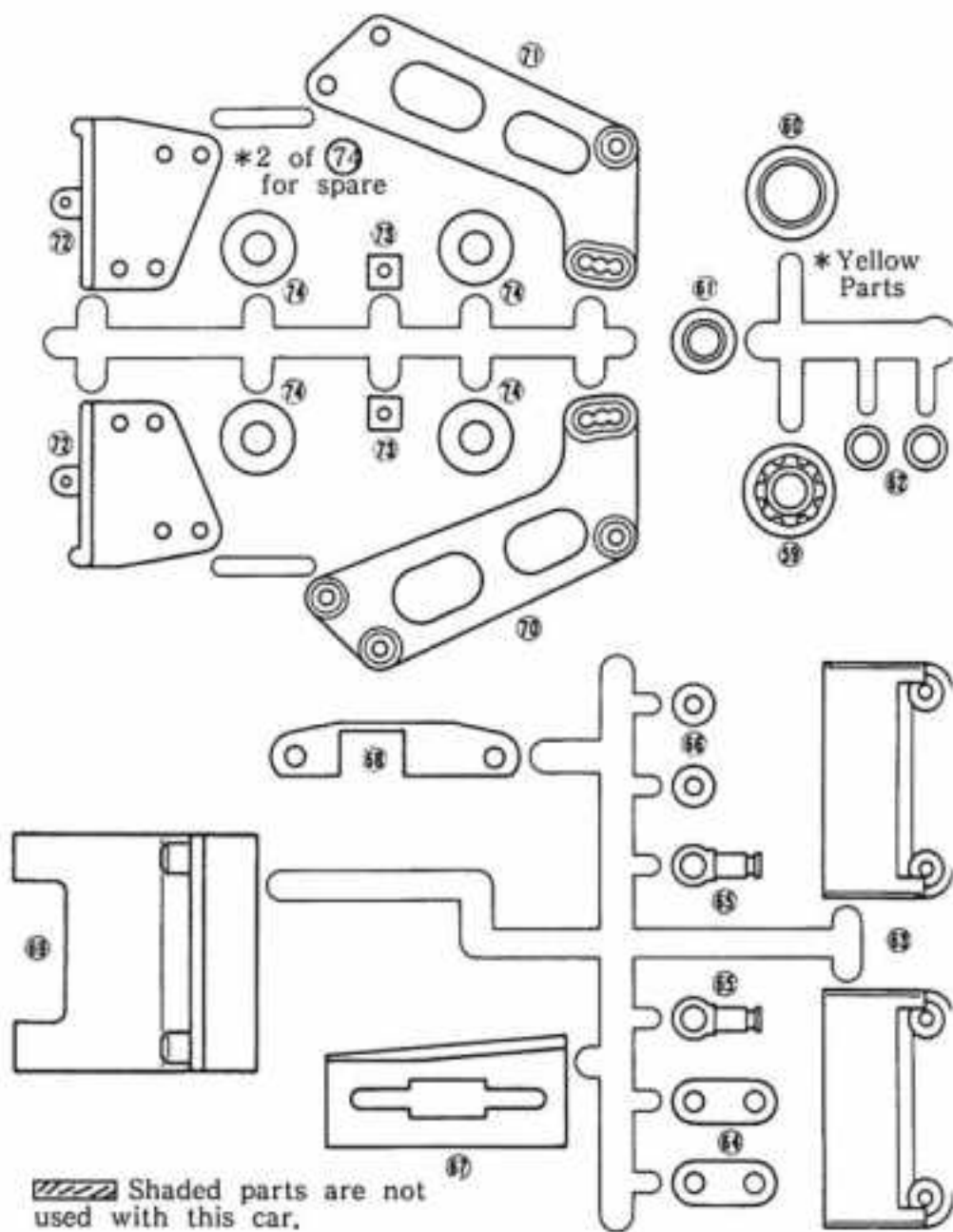

1 ASSEMBLY OF REAR GEARBOX

Keep the header by putting it in the bag or taping it down.



M3x18 TP Round Head Screws...2

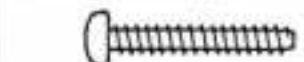

4 φ Washers...2



11 4 φ x8 Bearings...2



12 5 φ x8 Bearings...2



13 5 φ x10 Bearings...2



13 2 φ x11 Pin...1

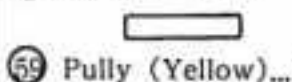

59 Pully (Yellow)...1



60 Pully Flange (Yellow)...1



62 5 φ Collar (S) (Yellow)...1



130 E Ring (E4)...2

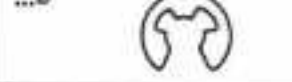

Step 1

2 Center Gear (Blister A)

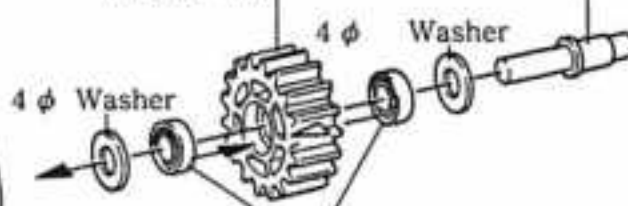

11 4 φ x8 Bearing (Blister B)

12 5 φ x8 Bearing (Blister B)

62 5 φ Collar (S) (Yellow) (TSE-6)

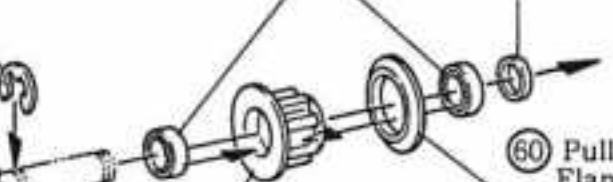

59 Pully (Yellow) (TSE-6)

60 Pully Flange (Yellow) (TSE-6)

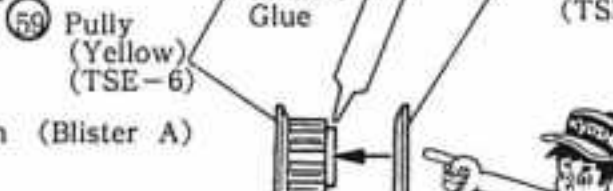

4 Main Gear Pinion (Blister A)

36 Main Gear Shaft (TSE-4)

Fix an E ring using a pair of pliers.

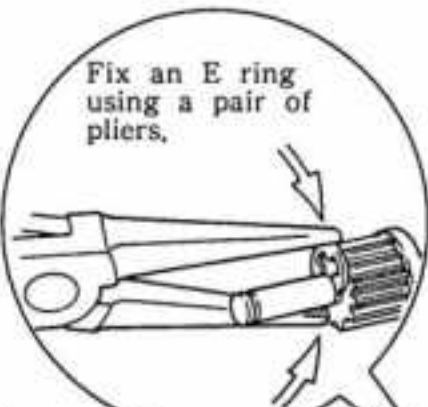

13 2 φ x11 Pin (TSE-4)

130 E Ring (E4) (TSE-1)



Step 2

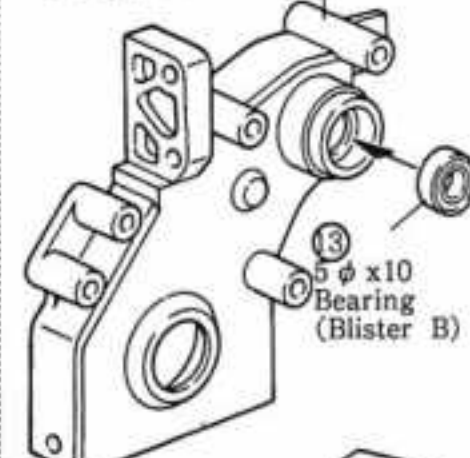

13 5 φ x10 Bearing (Blister B)

Step 3 [Adjustment of Ball Diff.]

The drawing shows the rear differential, you adjust the front differential in the same way.

1 The diff. body should not turn idly.

Check to see if the differential body will turn idly or not by holding both ends of the diff. shaft with screwdriver. If it does, adjust it as shown at right.

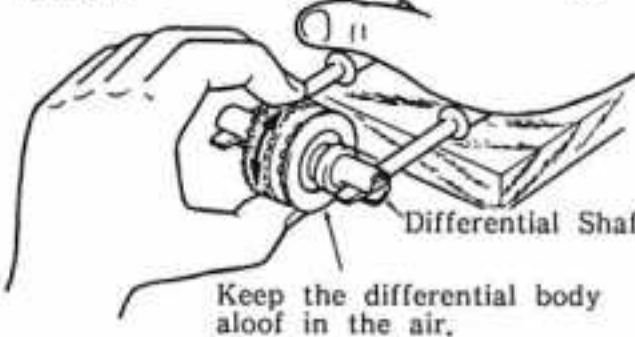

Keep the differential body aloof in the air.

The adjustment will be done by tightening the cap screw. Repeat the tightening it till the directions described in 1 and 2 have been acquired.



*If you should tighten the cap screw excessively or leave the differential run idly, the balls or the plate inside would be broken.

When the adjustment is done..

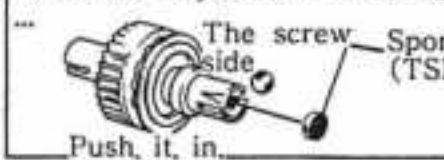

2 Be sure that the differential function is acquired.

When holding the differential body and turn the one side of the shaft, you should see the shaft at the other side rotate in the other direction.



(This is the result of the differential effect.) The more you tighten the cap screw, the less the effect becomes.

Step 4

23 Rear Gearbox (L)

Install the parts into the gearbox in order from 1 to 3 and engage the toothed belt and bolt the gearbox (L) in position.

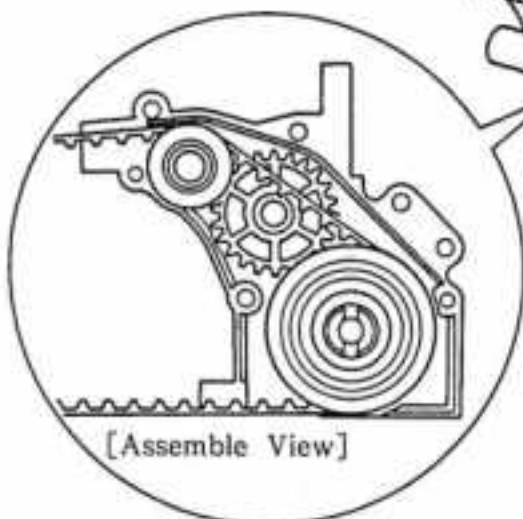

[Assemble View]

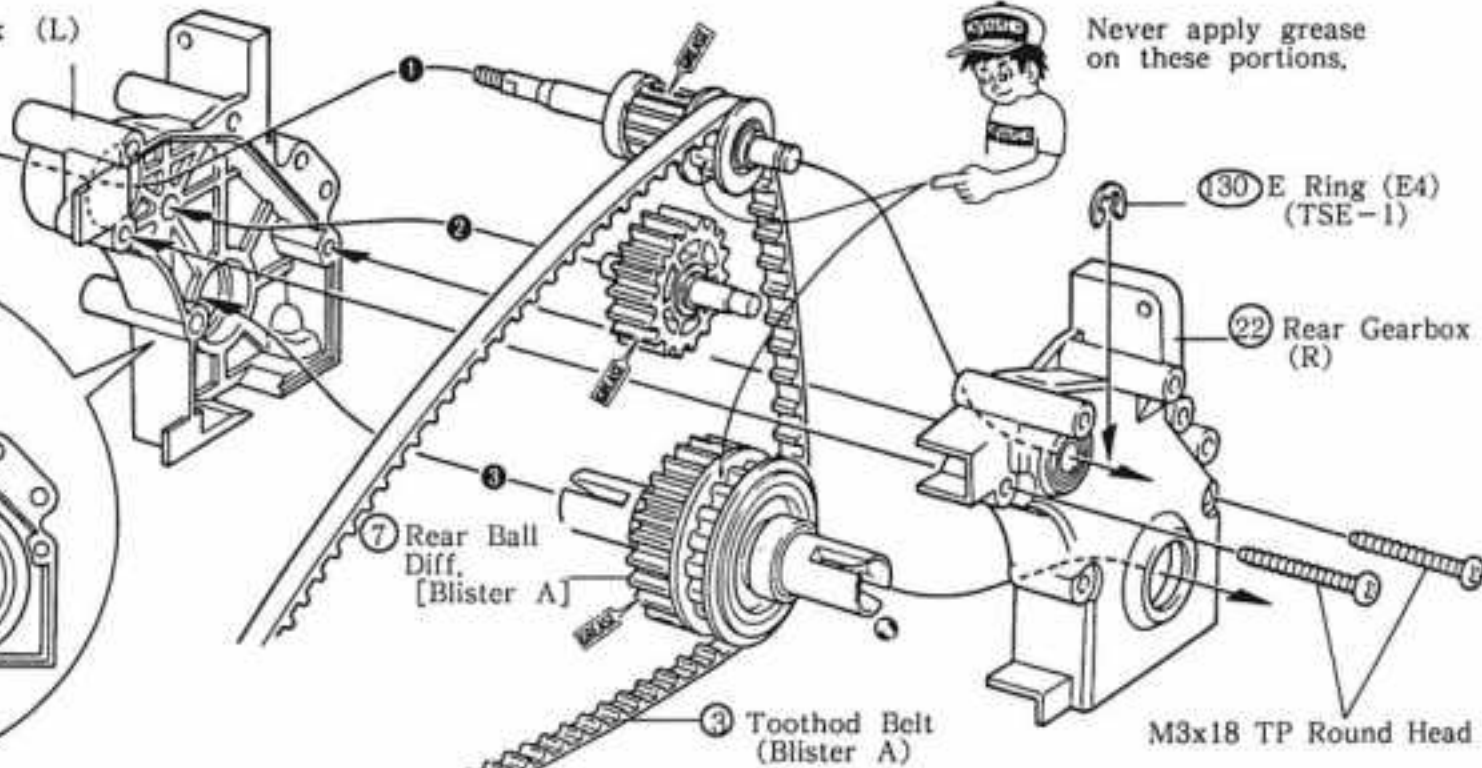

Never apply grease on these portions.

130 E Ring (E4) (TSE-1)

22 Rear Gearbox (R)

7 Rear Ball Diff. (Blister A)

3 Toothed Belt (Blister A)

M3x18 TP Round Head

2 INSTALLATION OF REAR PLATE

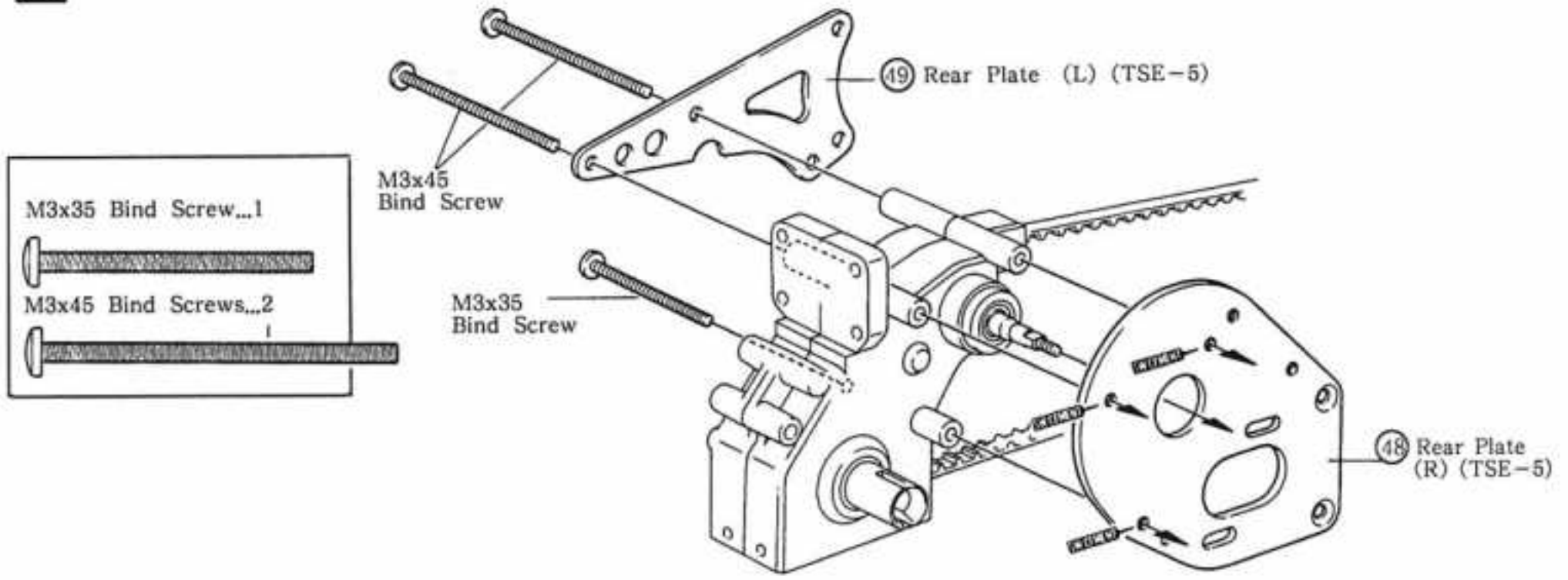

3 INSTASLLATION OF SPUR GEAR

When having assembled it as shown in the drawing at right, and if you find too much end play in the shaft, remove the E-ring on this side once and put another one (26) or two.

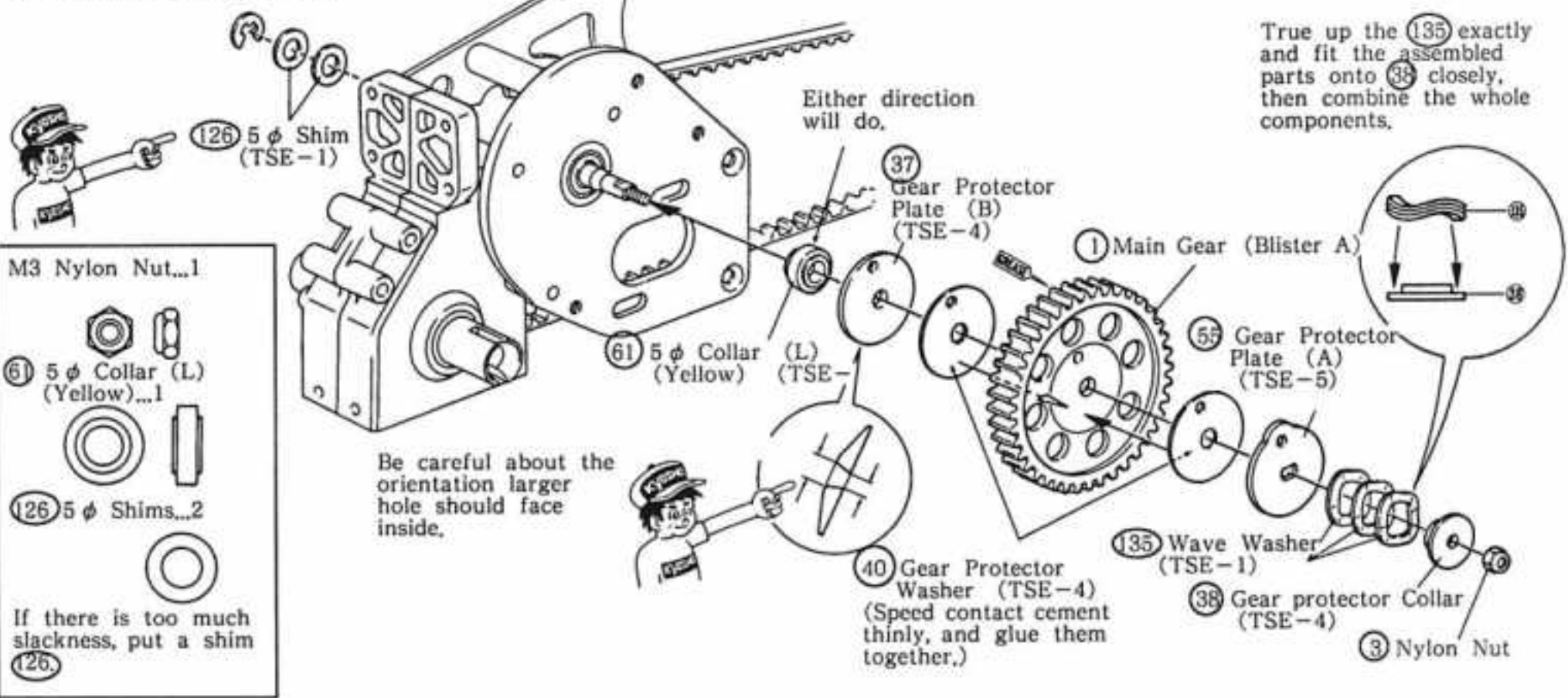

4 INSTALLATION OF UPPER ROD PLATE

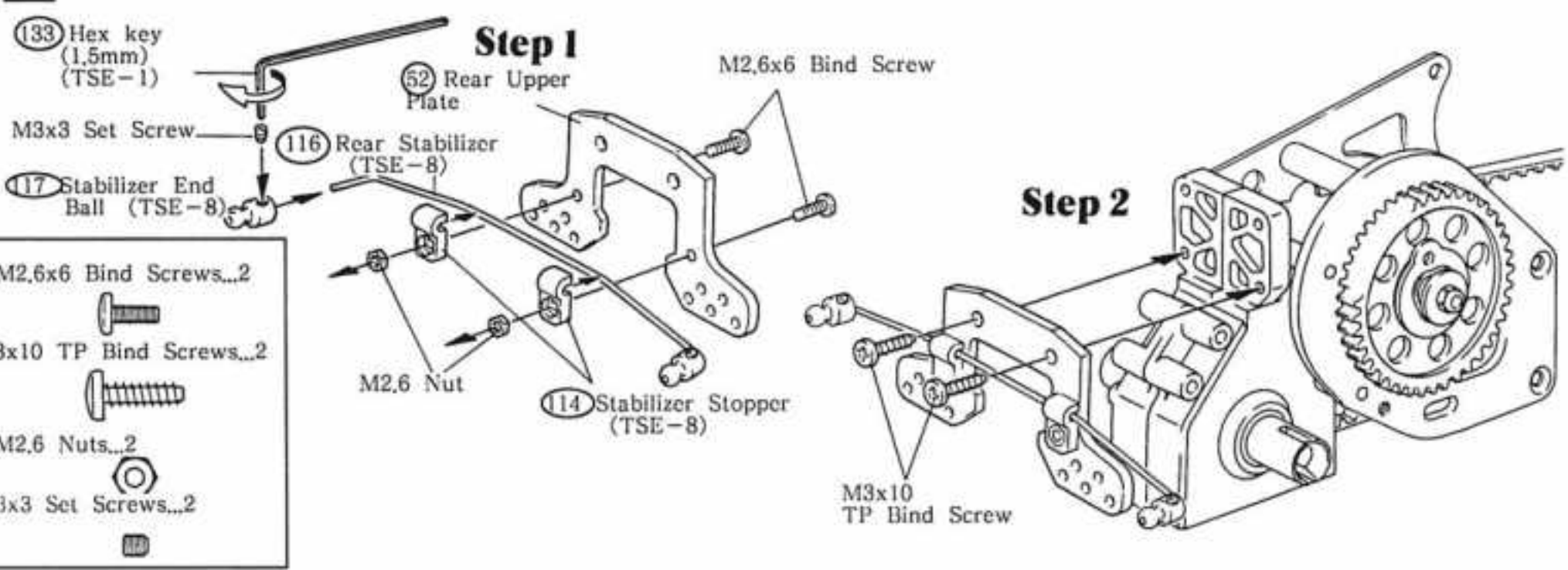

5 ASSEMBLY OF FRONT GEARBOX

- M3x6 TP Bind Screws...2 M3x18 TP Round Screws...2
 M3x10 TP Bind Screws...4 M3x18 Bind Screws...2 M3 Nuts
 2
-

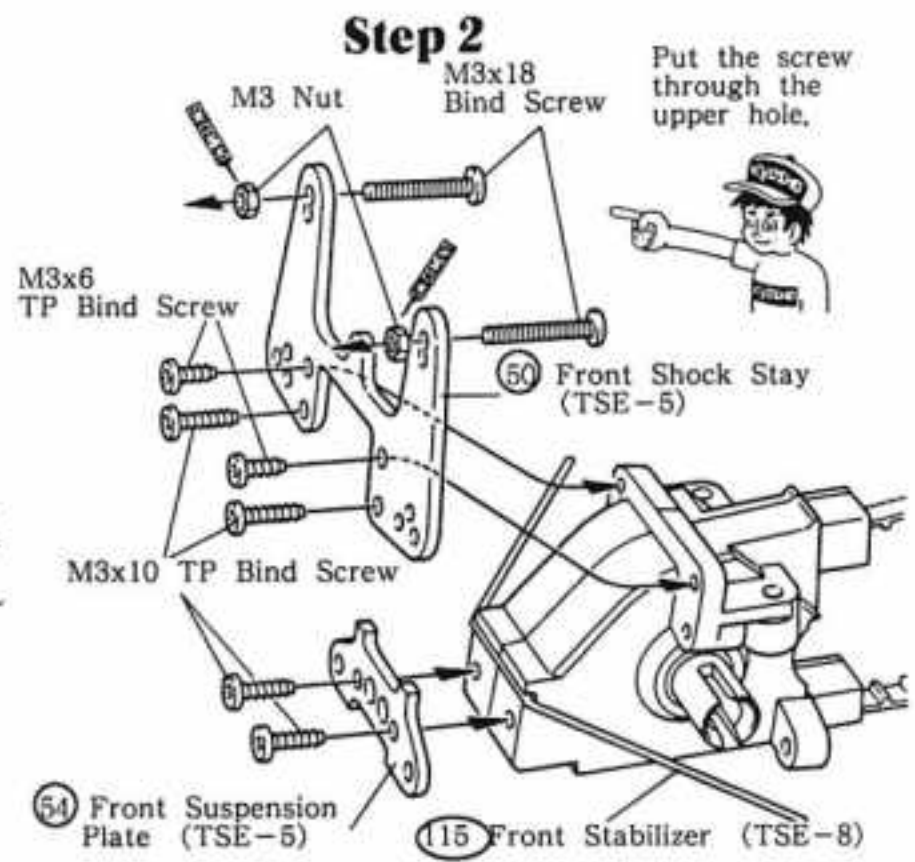
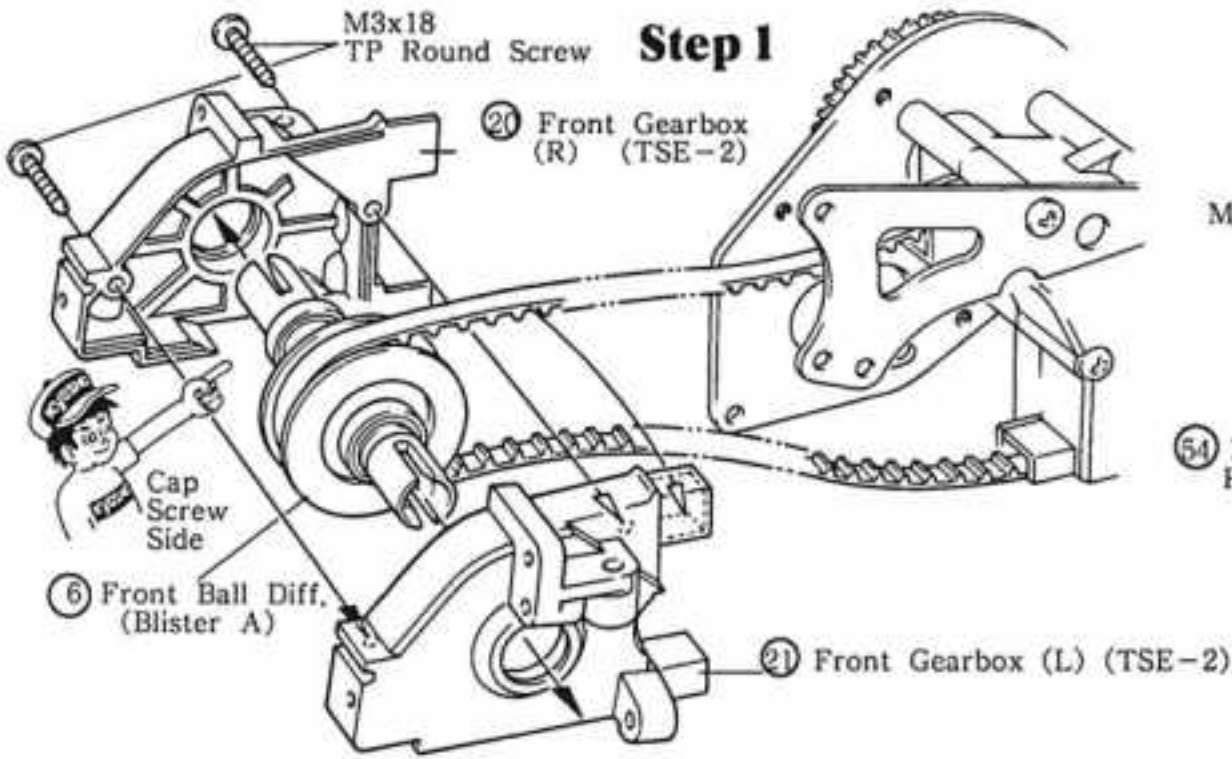

6 INSTALLATION OF GEARBOX

- M3x10 TP Bind Screws...2
 M3x10 TP Flat Head Screw...5
 M3x15 TP Flat Head Screw...1
 M3x18 Bind Screws...2
 M3 Nuts...2
-

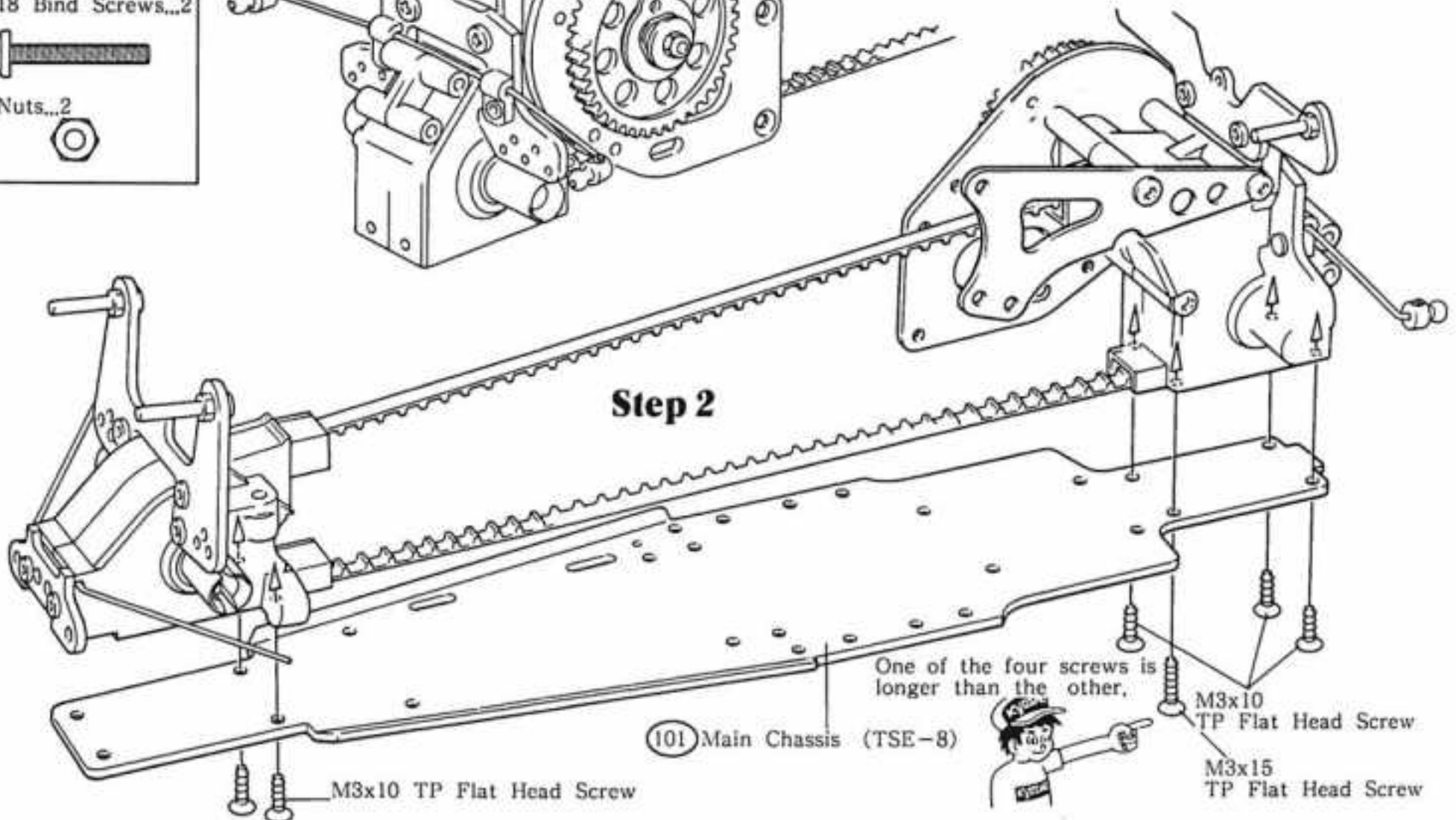
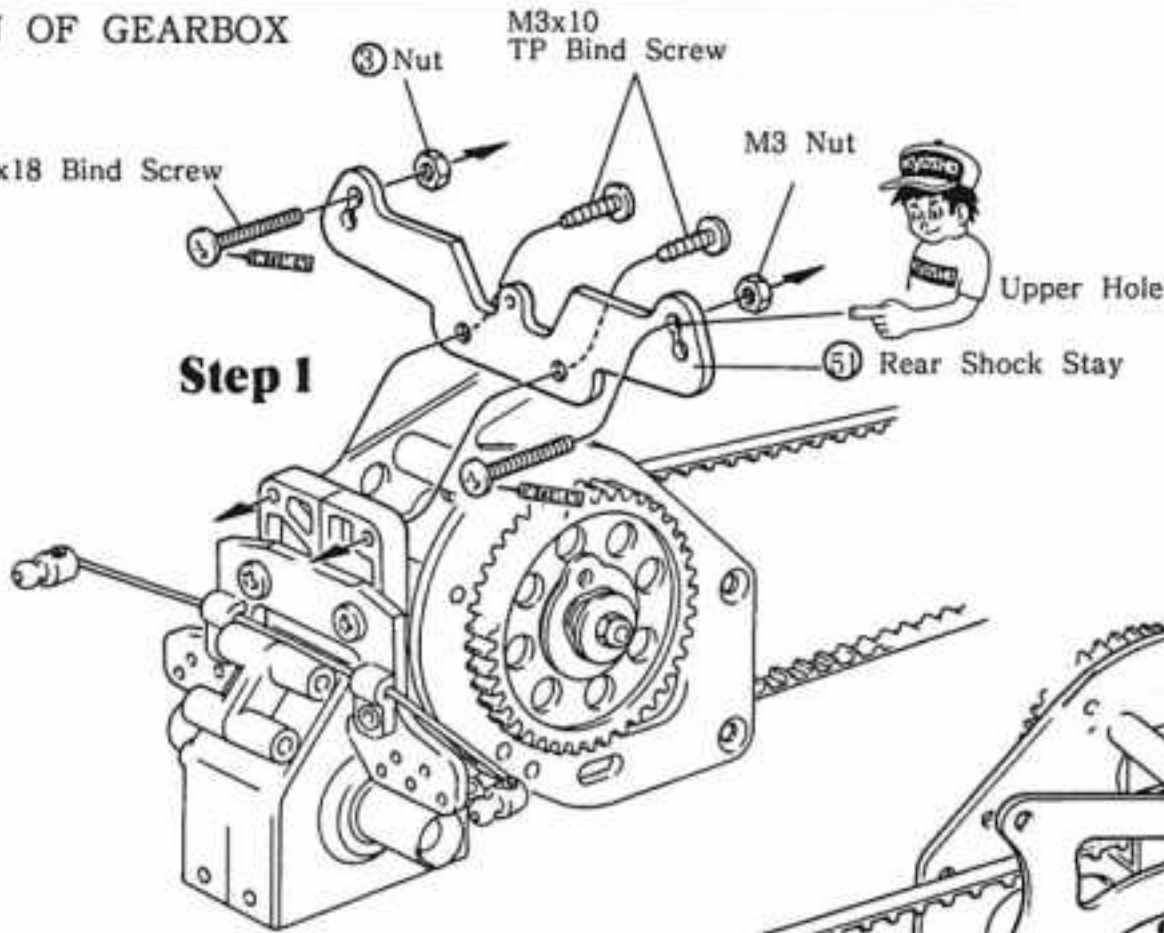

7 INSTALLATION OF BELT COVER (A) (A) After cutting out this part, clean the surface, particularly make it free from oily stain, where ③① is to be cemented.

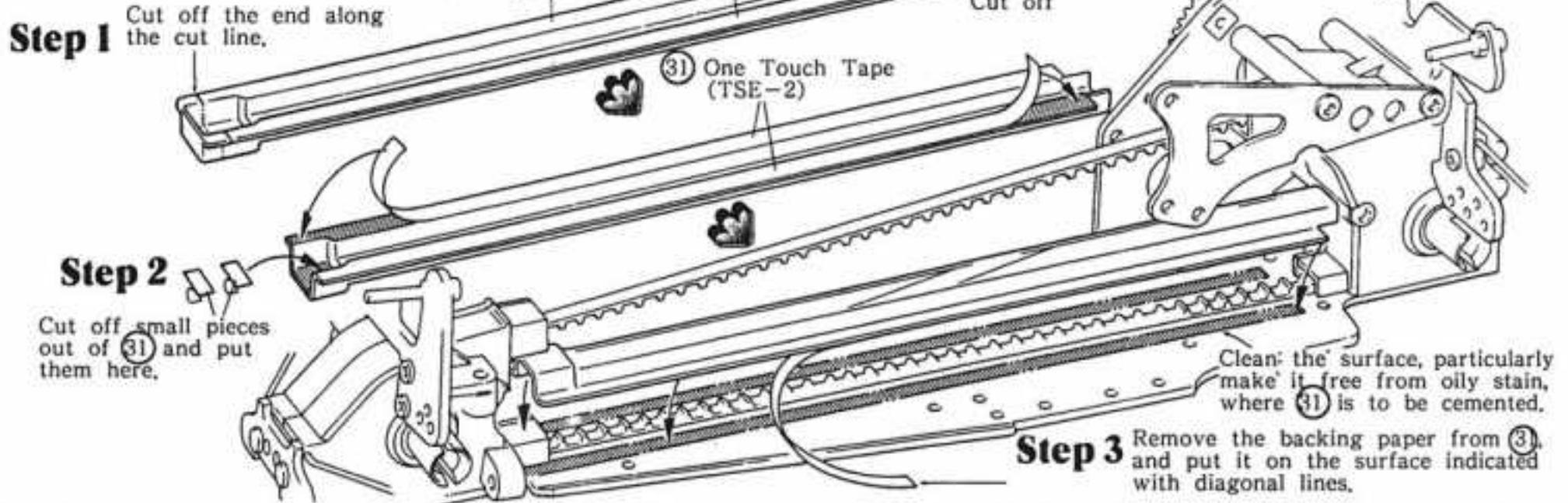

8 INSTALLATION OF CHASSIS (UPPER)

Screw locking compound prevents dusts from entering through the belt cover and the chassis.

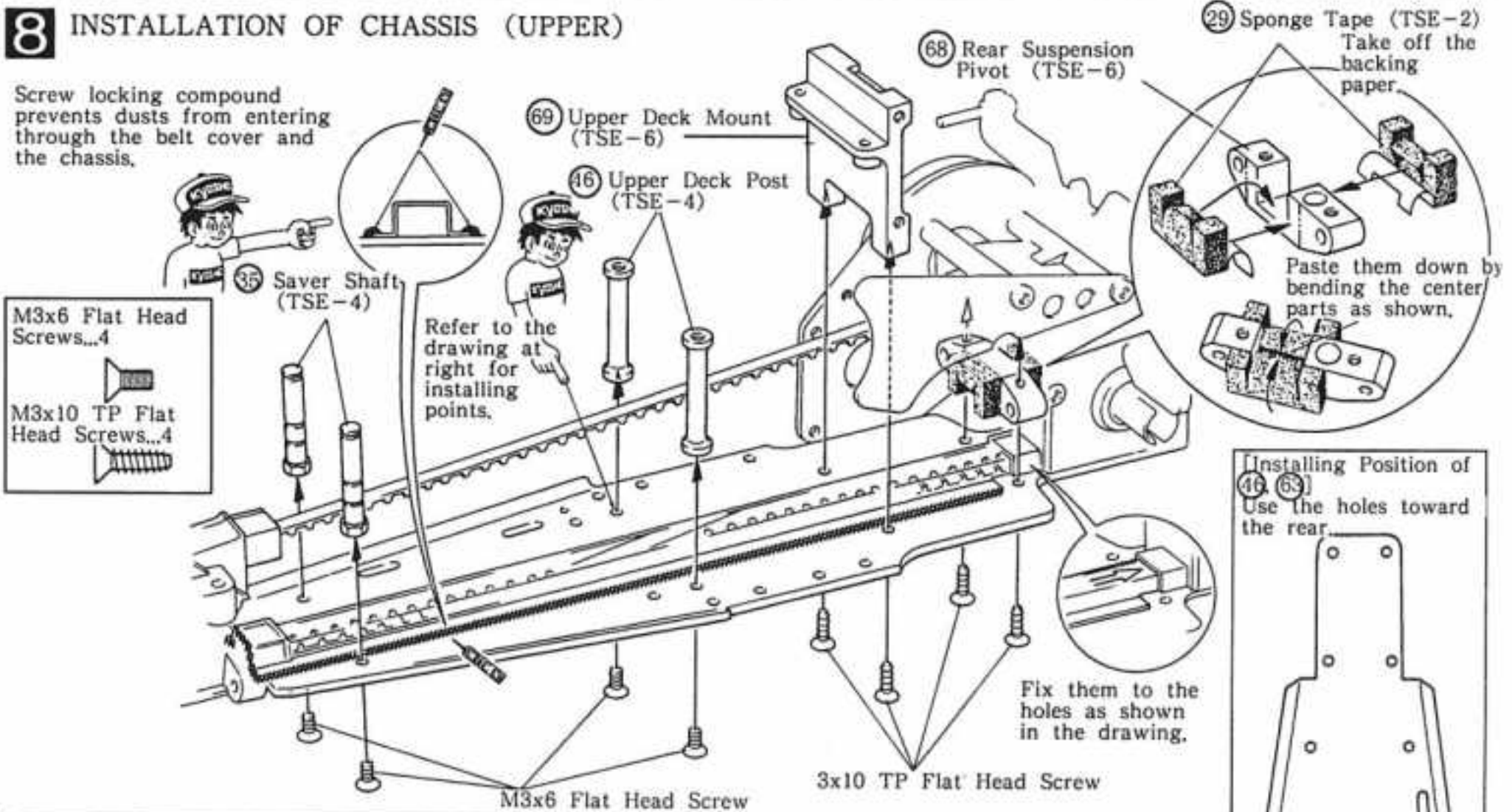

9 INSTALLATION OF BATTERY HOLDER

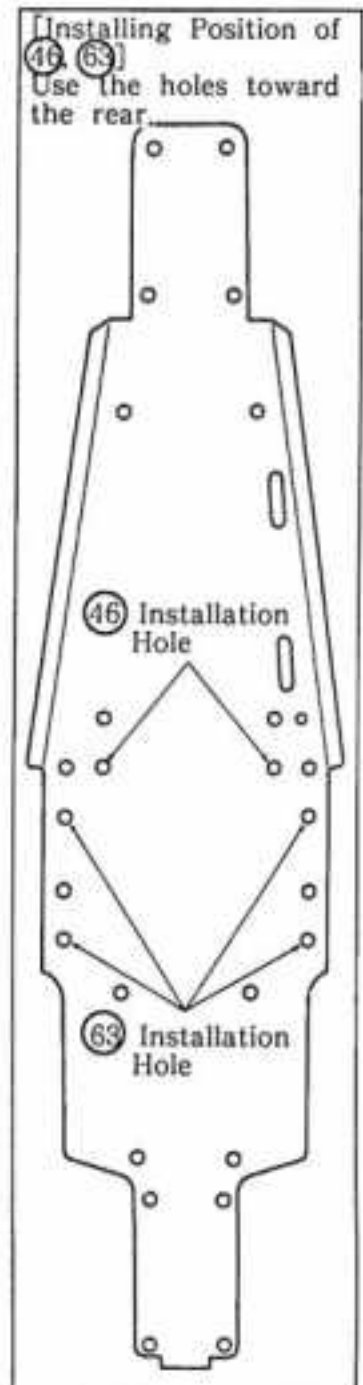
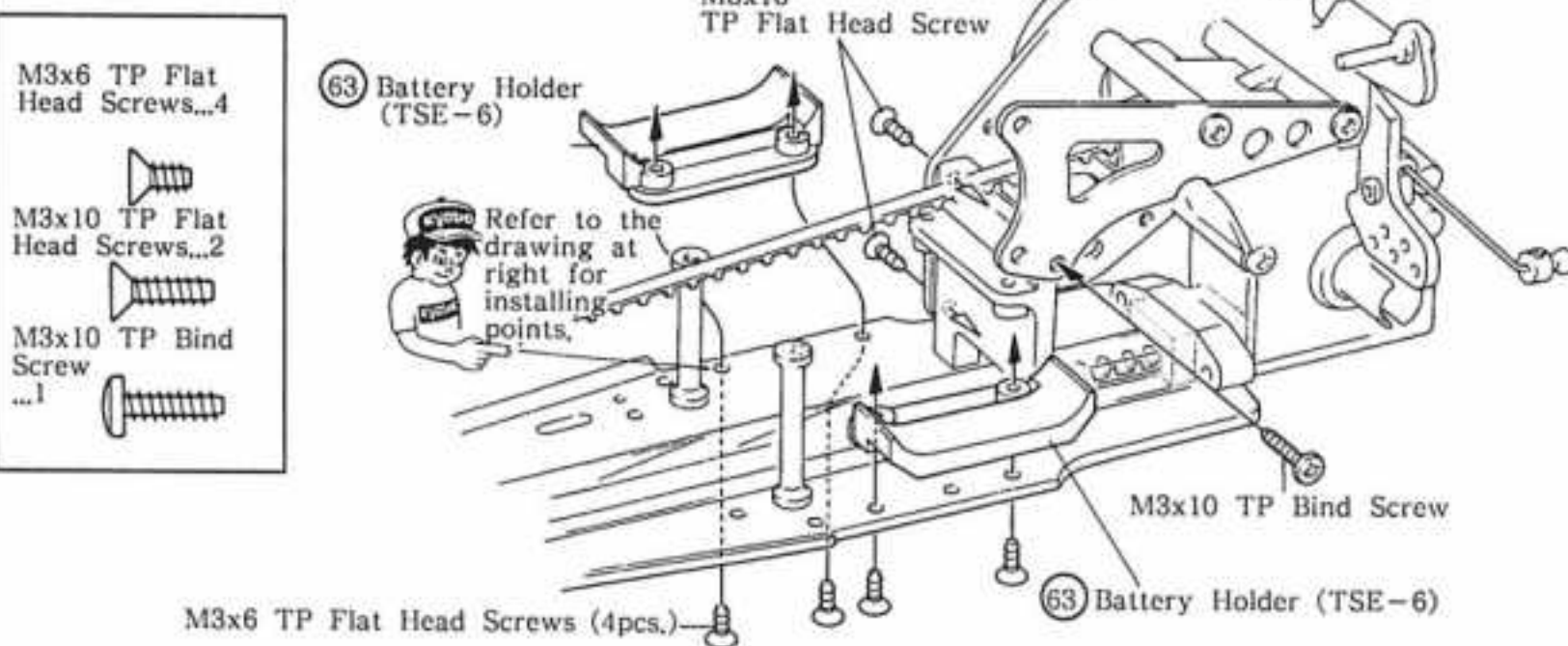

10 ASSEMBLY OF KNUCKLE ARM

- M2.6 Nuts...2
- 13 5 φ x10 Bearings ...4
- 90 M2.6 Pillow Balls (Black)...2

Step 1 [RIGHT]

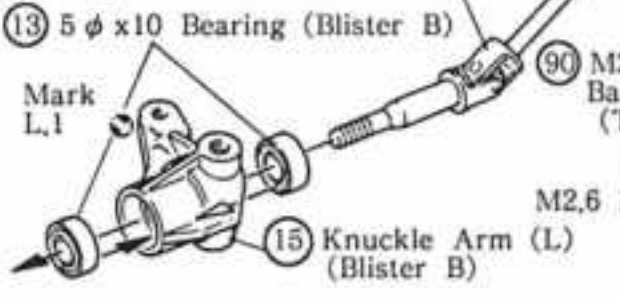

Step 2

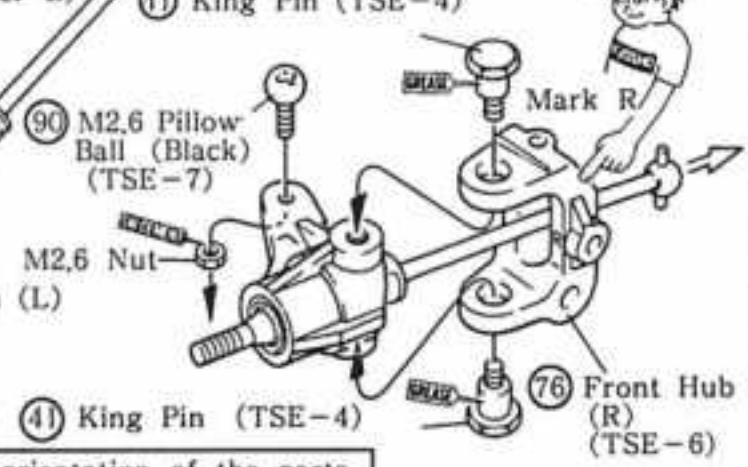

Step 3 [LEFT]

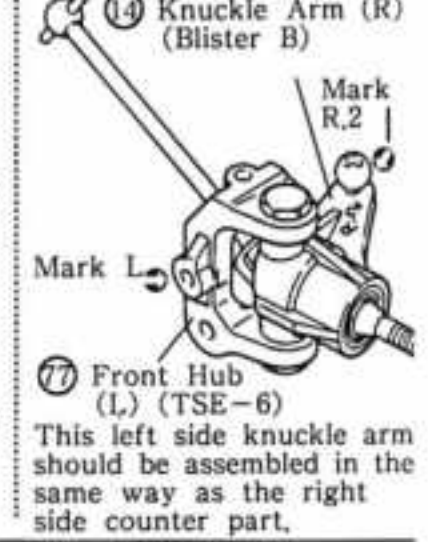

*Be careful about the marking and the orientation of the parts.

11 INSTALLATION OF FRONT SUSPENSION ARM

Fix the part 65 reversely on the left side.

- 87 Sus. Shafts (A) (Silver)...2
- 89 M3 Pillow Balls (Silver) ...2
- 94 Sus. Shafts (C) (Silver)...2
- 100 4.8 φ Balls...2
- 128 E Rings (E2.5) (Silver)...6
- 129 E Rings (E3) (Black)...2

Step 1 [RIGHT]

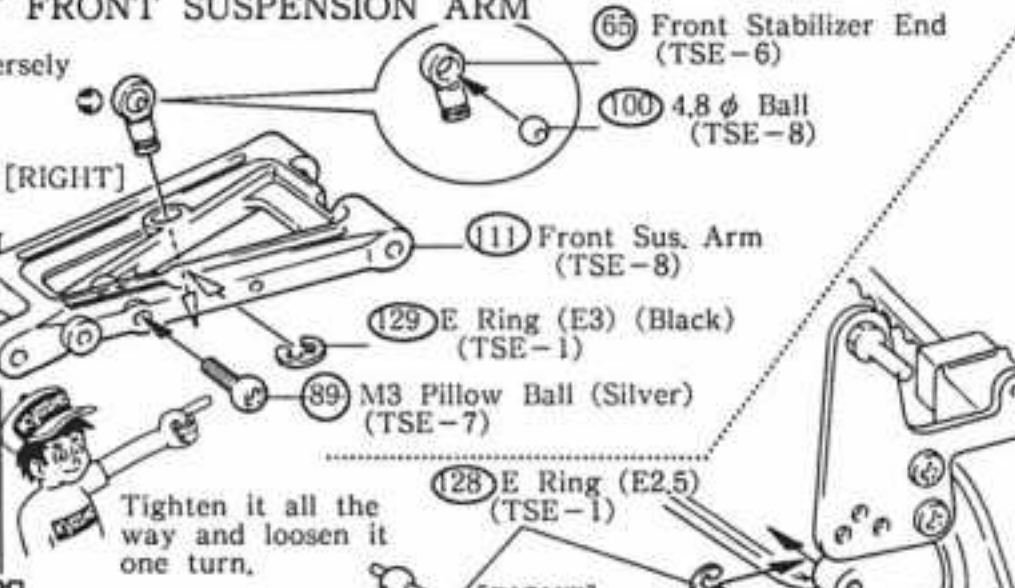

Step 2

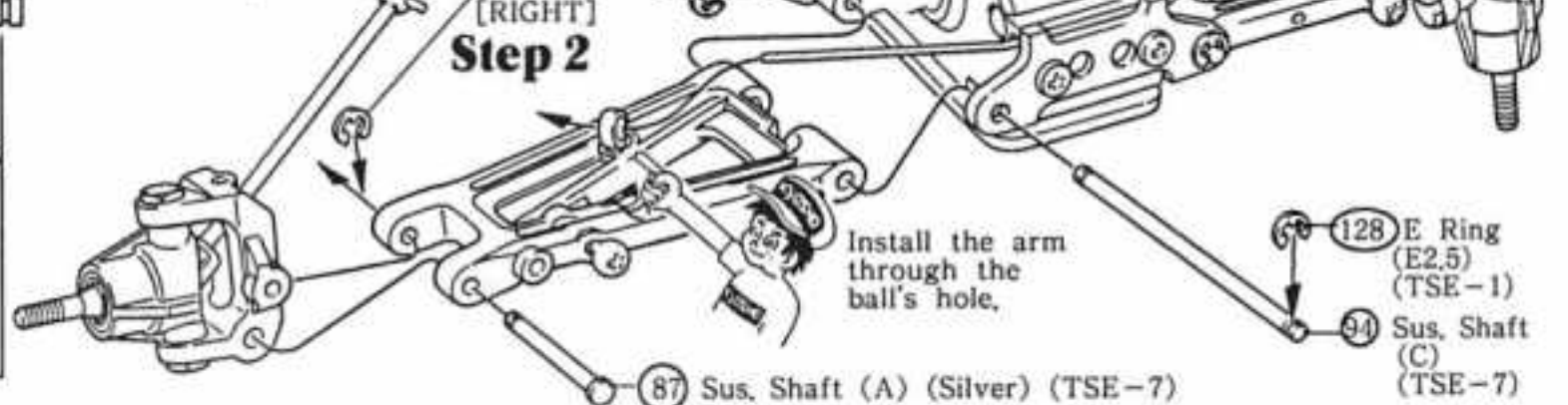

12 INSTALLATION OF FRONT UPPER ROD

- M2.6x12 Bind Screws...2
- M3x12 Flat Head Screws...2
- M:15TP Flat Head Screws...2
- M2.6 Nuts...4
- 12 5.8 φ Balls (Black)...2
- 91 5.8 φ Balls (Silver)...2
- 92 Ball Ends (L)...4
- 99 Upper Rods...2

Step 1

Drive ball-ends into upper-rod as shown at right (two each right and left respectively).

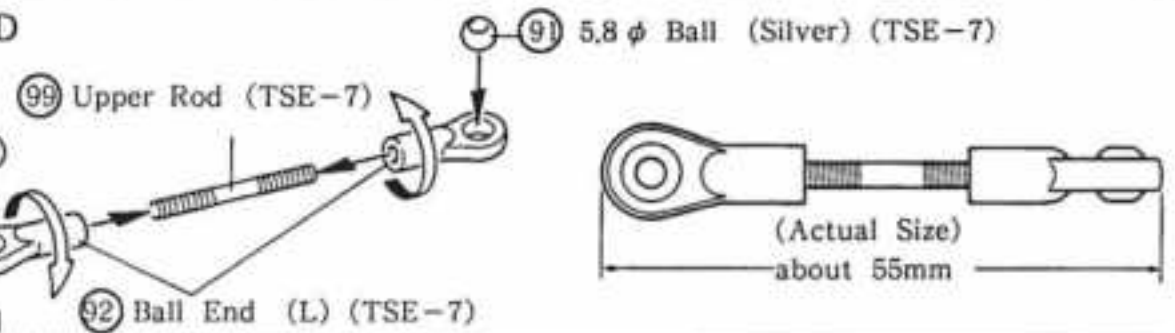

Step 2

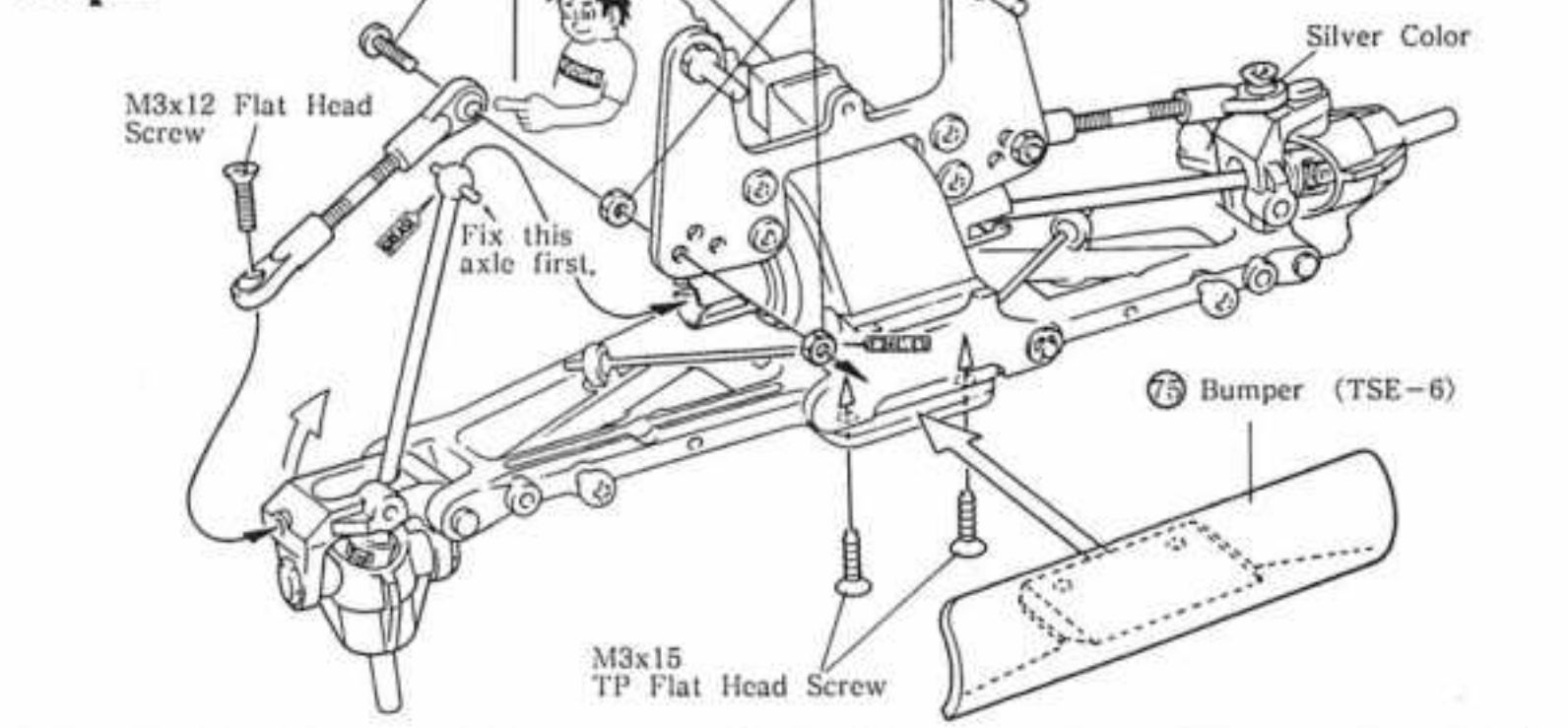

13 INSTALLATION OF REAR HUB

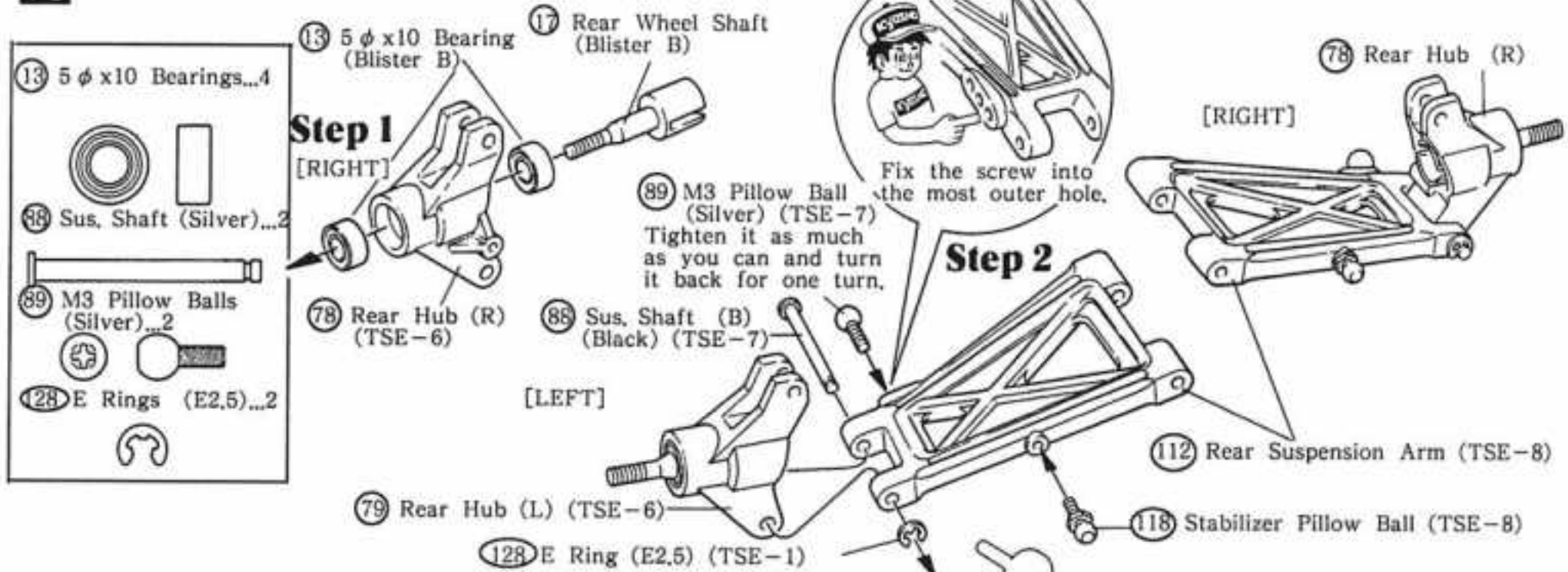

14 INSTALLATION OF REAR SUSPENSION ARM

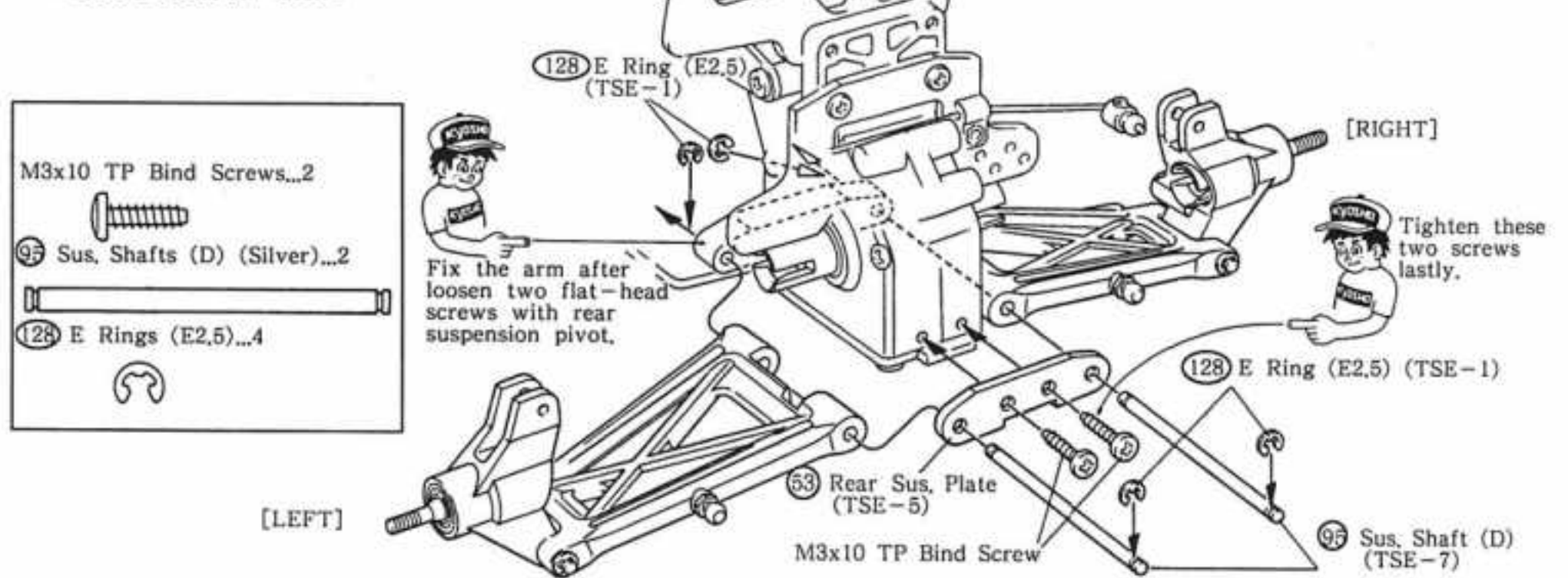

15 INSTALLATION OF REAR UPPER ROD

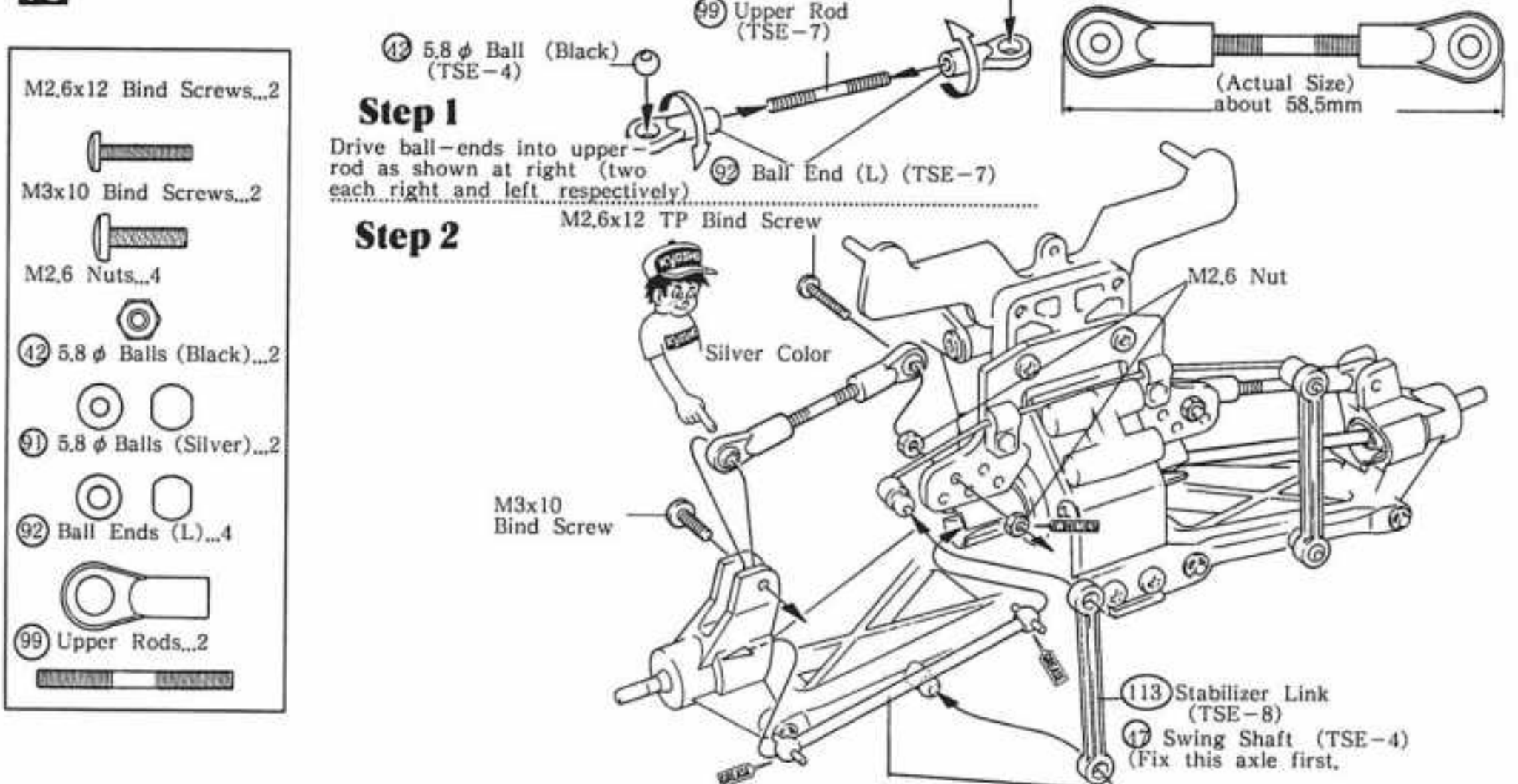

16 ASSEMBLY OF SERVO SAVER

Step 1

Cut off the shaded area so that the ball end should measure 19 mm long.

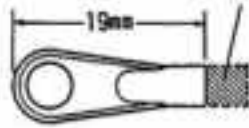

45 Ball Nut (TSE-4)

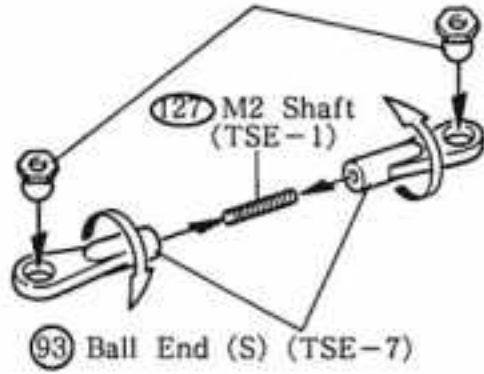

93 Ball End (S) (TSE-7)

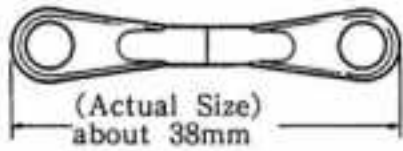

M2,6x6 Bind Screw...1

2,6 φ Washers (Black) ...4

45 Ball Nuts...3

90 M2,6 Pillow Balls (Black)...2

93 Ball Ends (S)...2

127 M2 Shshaft...1

Step 2

Cut away the unnecessary with a pair of pliers.

83 Servo Saver (D) (TSE-6)



82 Servo Saver (C) (TSE-6)

Step 3

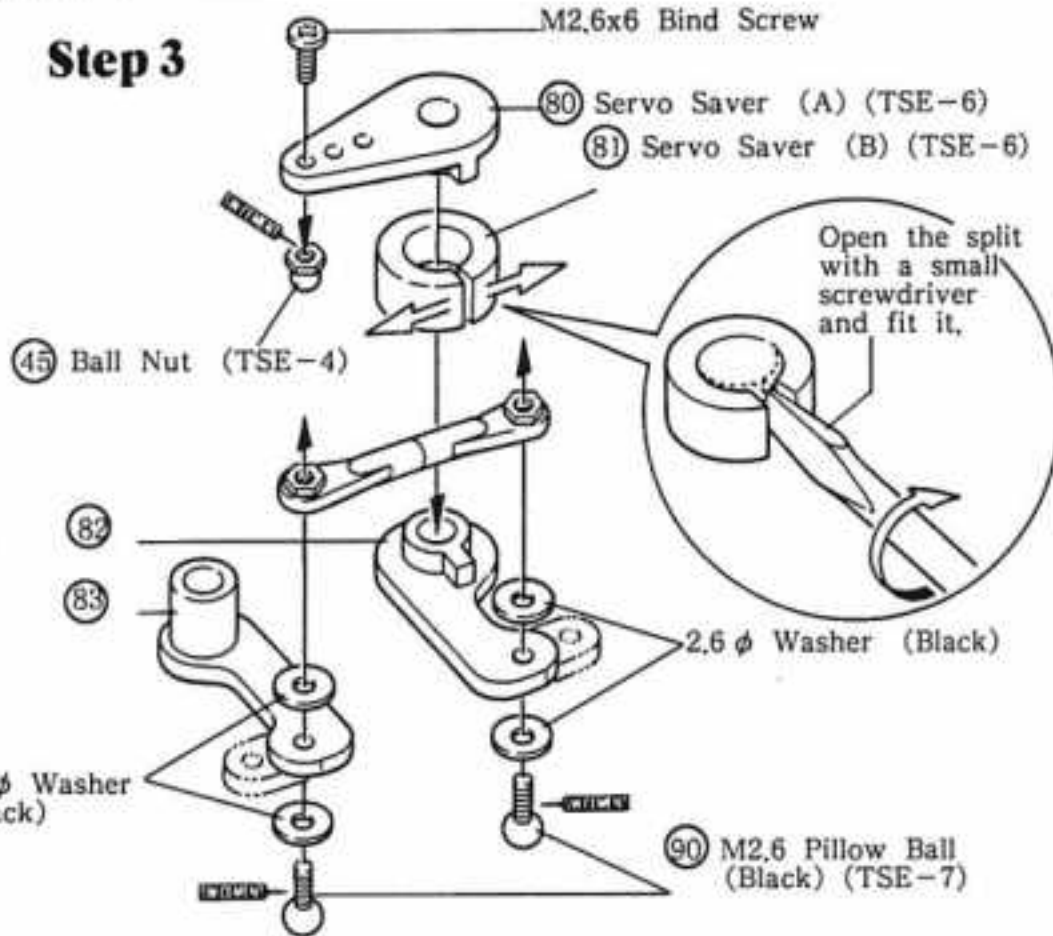

17 INSTALLATION OF SERVO SAVER

130 E Ring (E4) (TSE-1)

84 Servo Saver Collars...2

126 5 φ Shims...2

If there is too much slackness, put a shim (126)

130 E Rings (E4)...2

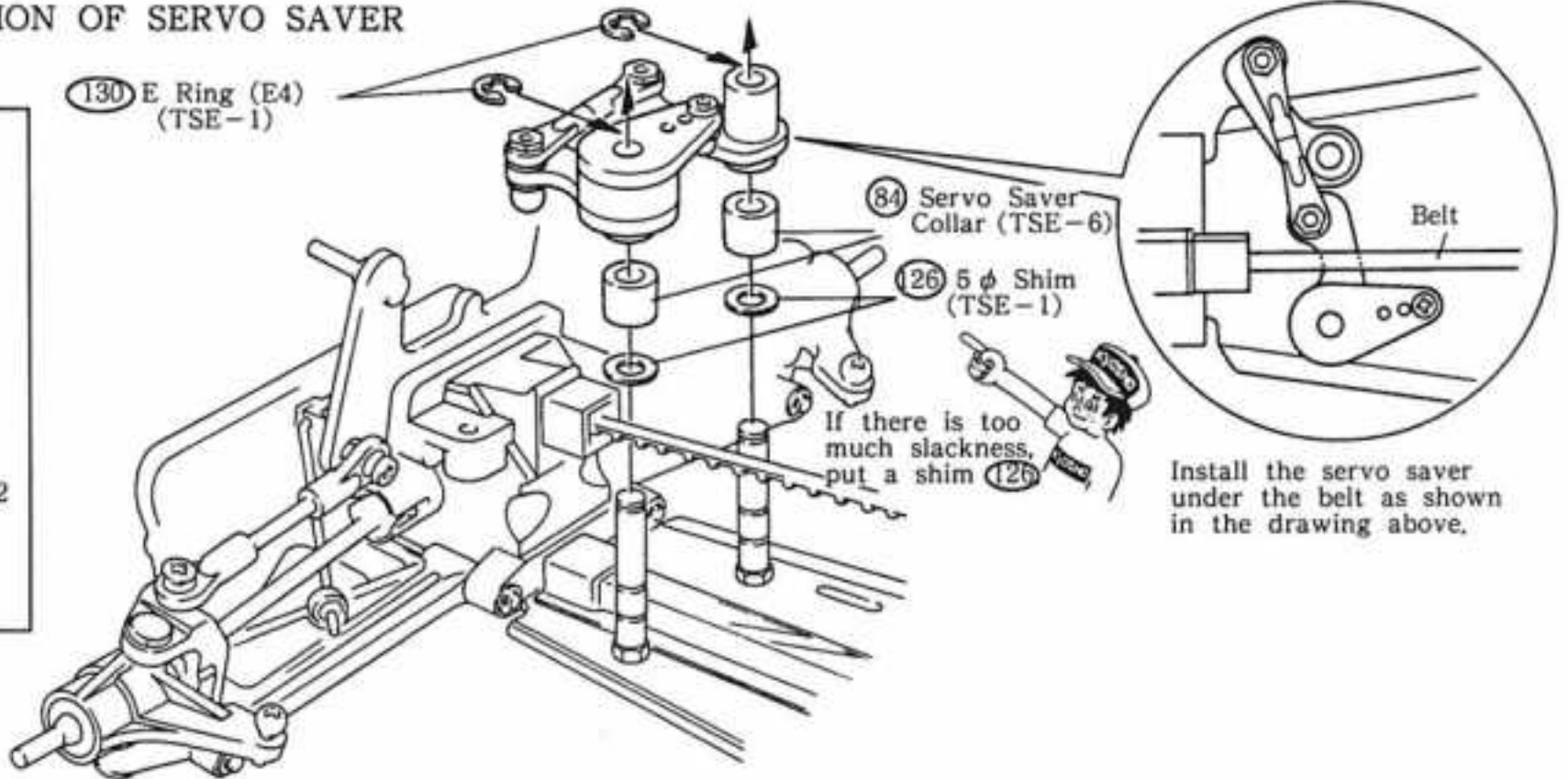

18 INSTALLATION OF TIE ROD

92 Ball Ends (L)...4

92 Ball End (L) (TSE-7)

Step 1

Drove ball-ends into tie-rod as shown below two each right and left respectively)

98 Tie Rod (TSE-7)

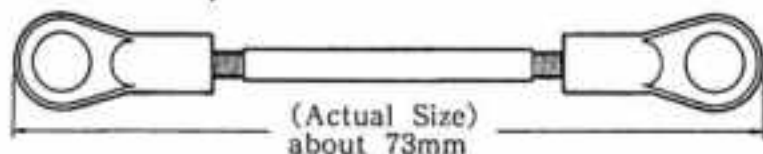

Step 2

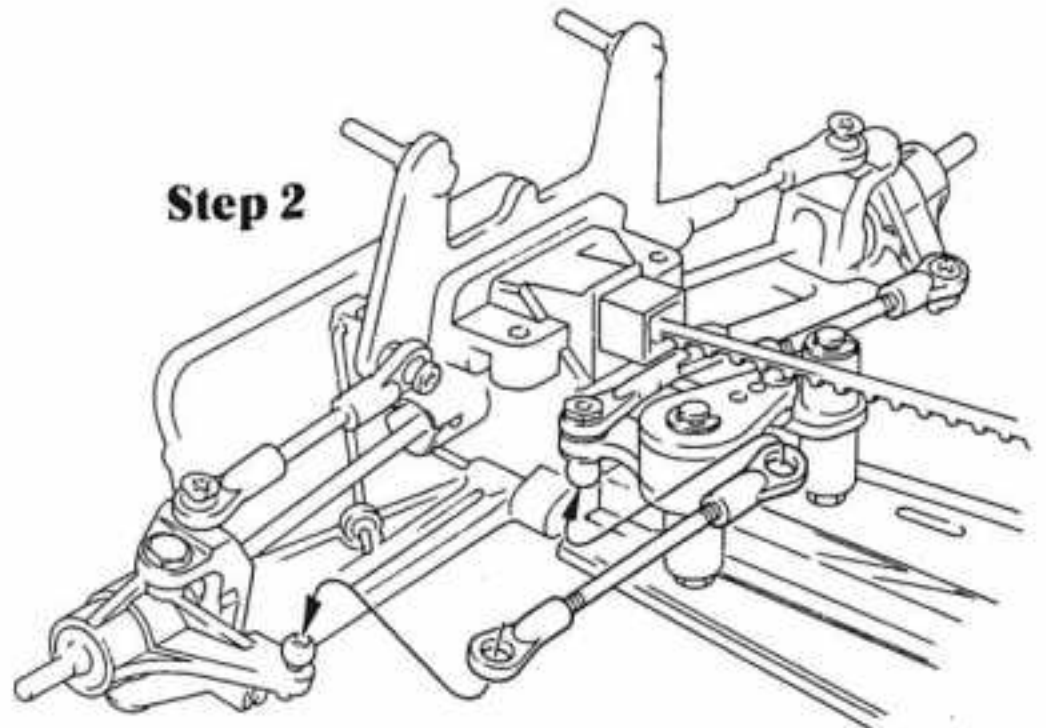

19 FULLING THE SHOCK OIL

Step 1 Squeeze spring put off spring stopper.

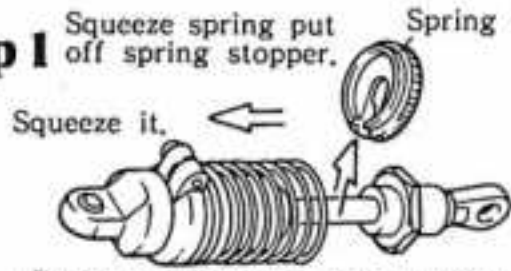

- ⓑ Front Adjustable Shock (Blister A)
- ⓐ Rear Adjustable Shock (Blister A)

Step 2 Put off spring and shock top cap.

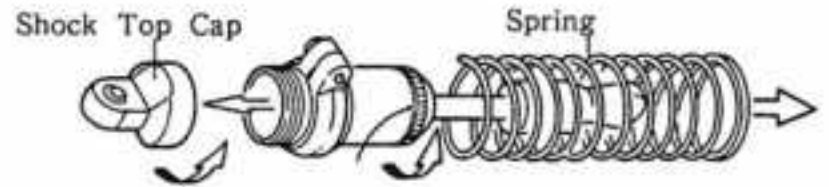

[Adjustment of Shock Absorbing Power]
By diversifying the effectiveness of the shock, you can give some range of running characteristics to your model car.

Step 3 [Filling the Oil]

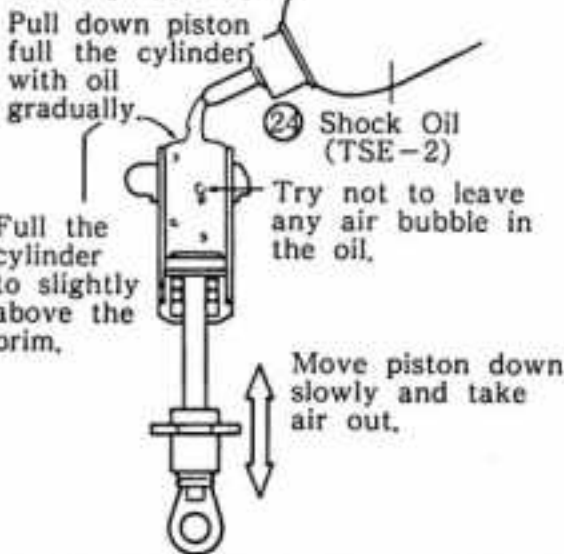

Step 4



Step 5 Compress the spring in order to put the spring stopper (B).

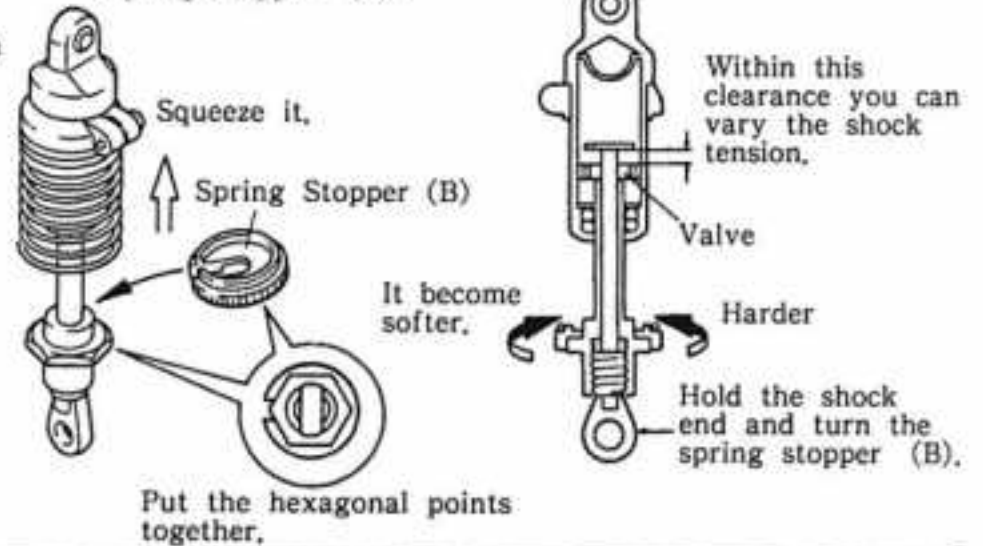

20 INSTALLATION OF SHOCK

[FRONT]

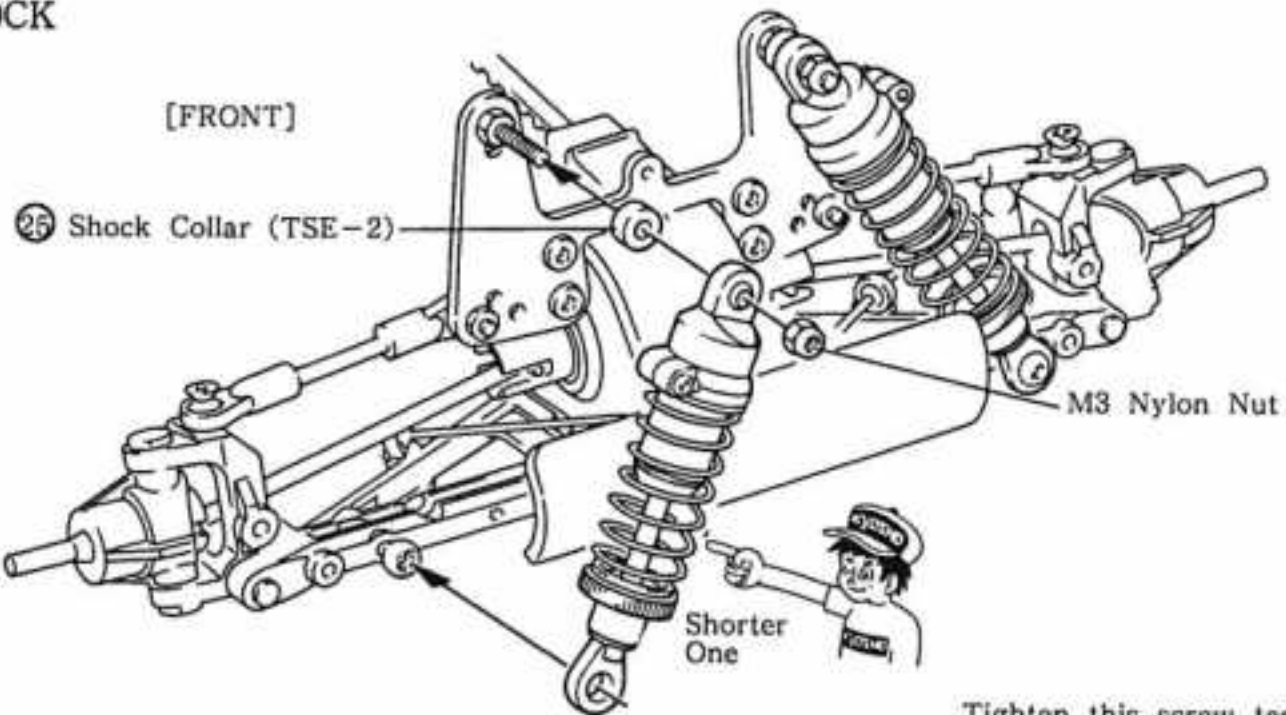

Tighten this screw temporarily, since the upper part of the shock will be unfastened for a short time in the step 28.

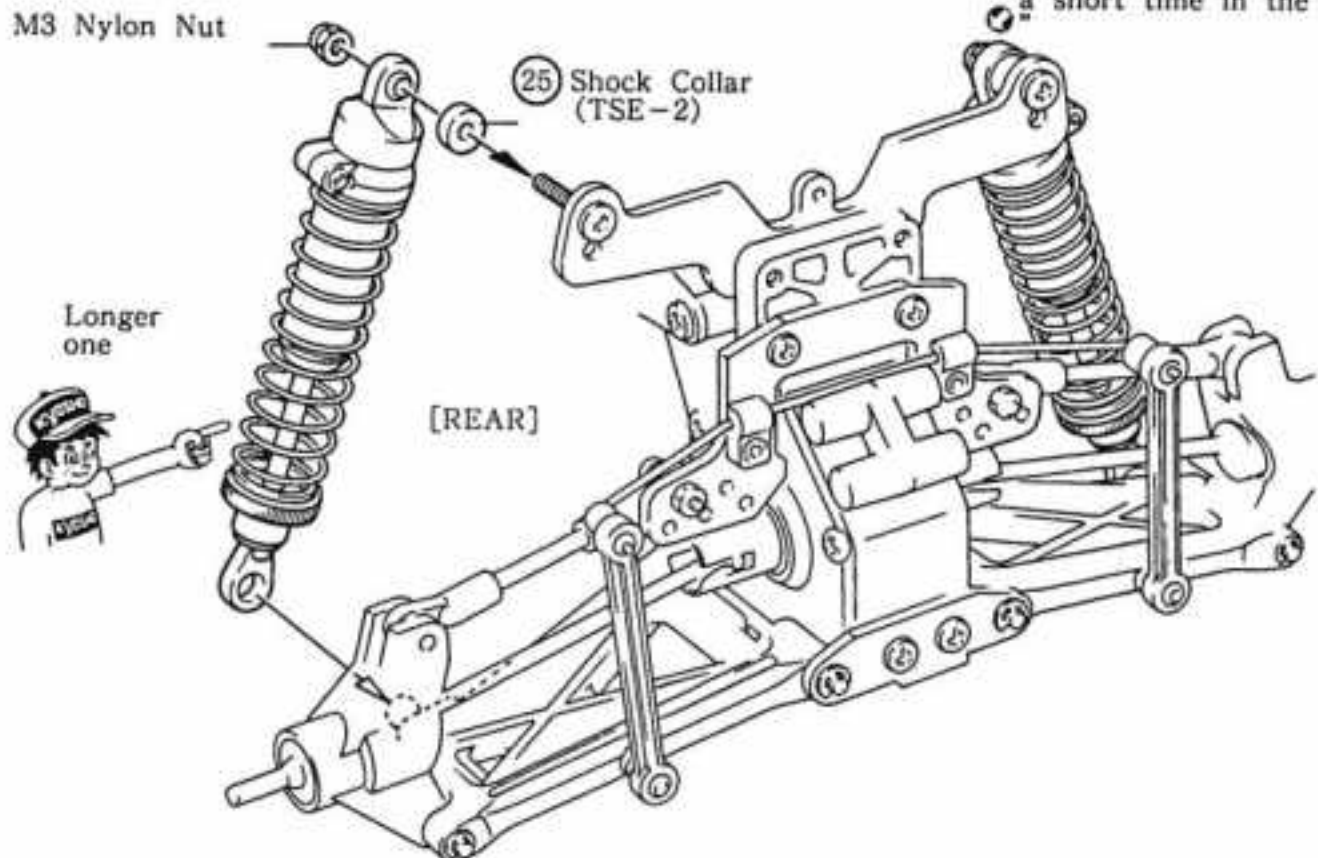

- M3 Nylon Nuts...4
-
- ⓐ Shock Collars...4
(3mm thick)
-

21 INSTALLATION OF MOTOR CORD

18 Le Mans 240ST Motor (Blister B)

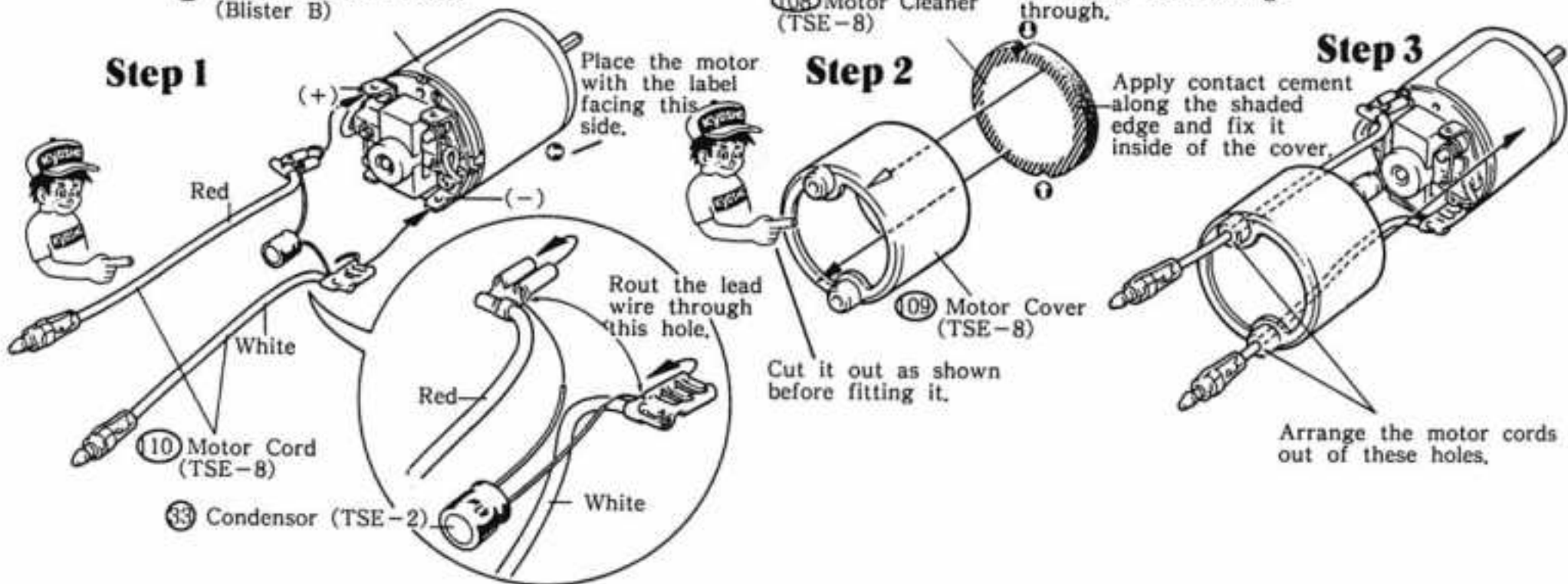

22 HOW TO CHECK RADIO SYSTEM

*Operate the radio units in numerical order.

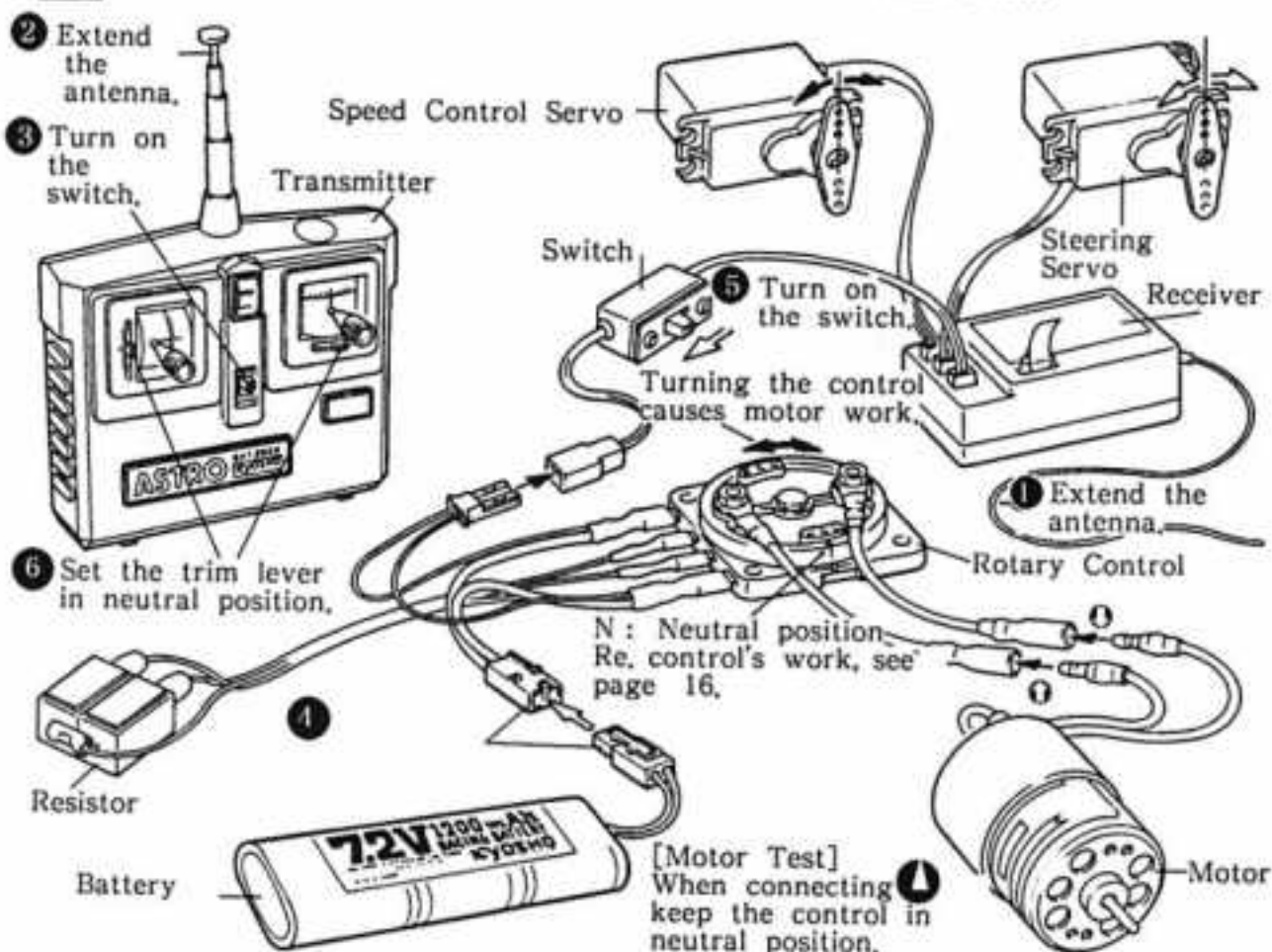

ONLY BEC SYSTEM RADIOS ARE AVAILABLE TO THIS CAR. A two channel radio is composed of things like a transmitter, receiver, servos, and battery

- *Transmitter... It is in effect a control box. Signal waves are transmitted through an antenna according to the stick movements.
- *Receiver..... Receives the signals from the transmitter and send them to the servos.
- *Servo..... They really move the control mechanism of a model car in accordance with the signals from the receiver.
- *Antenna..... An antenna on the transmitter sends signals, and one on the receiver accepts them. They should be fully extended.
- *Trim Lever... They will adjust the neutral position of servos, thus regulate the steering and advancing controls finely.
- *Battery..... You can tell the amount of electricity in a Meter
- *Servo..... They are intermediate devices on the servos to activate the controls. There are several types in shape. They should be selected depending upon the usage.

When switch on the radio...
Get the switches in order from transmitter to receiver.

When switch off the radio...
In order from receiver to transmitter.

23 INSTALLATION OF STEERING ROD

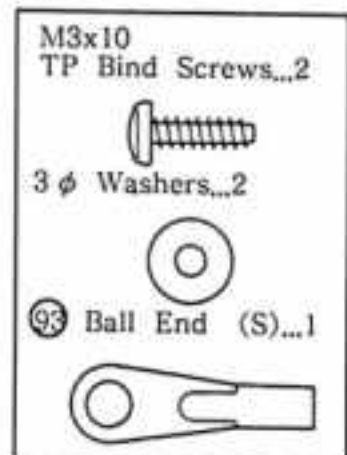

Step 1

Connect the control rod to the hole 13mm away from the center.

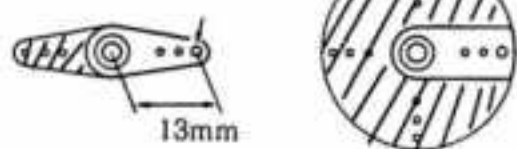

Step 2

Screw the ball-end once halfway of thread. Adjust the position in step 24.

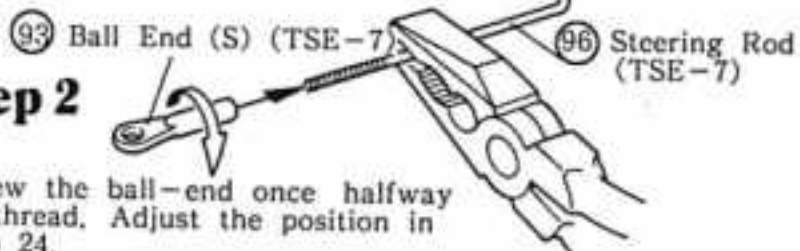

Step 3

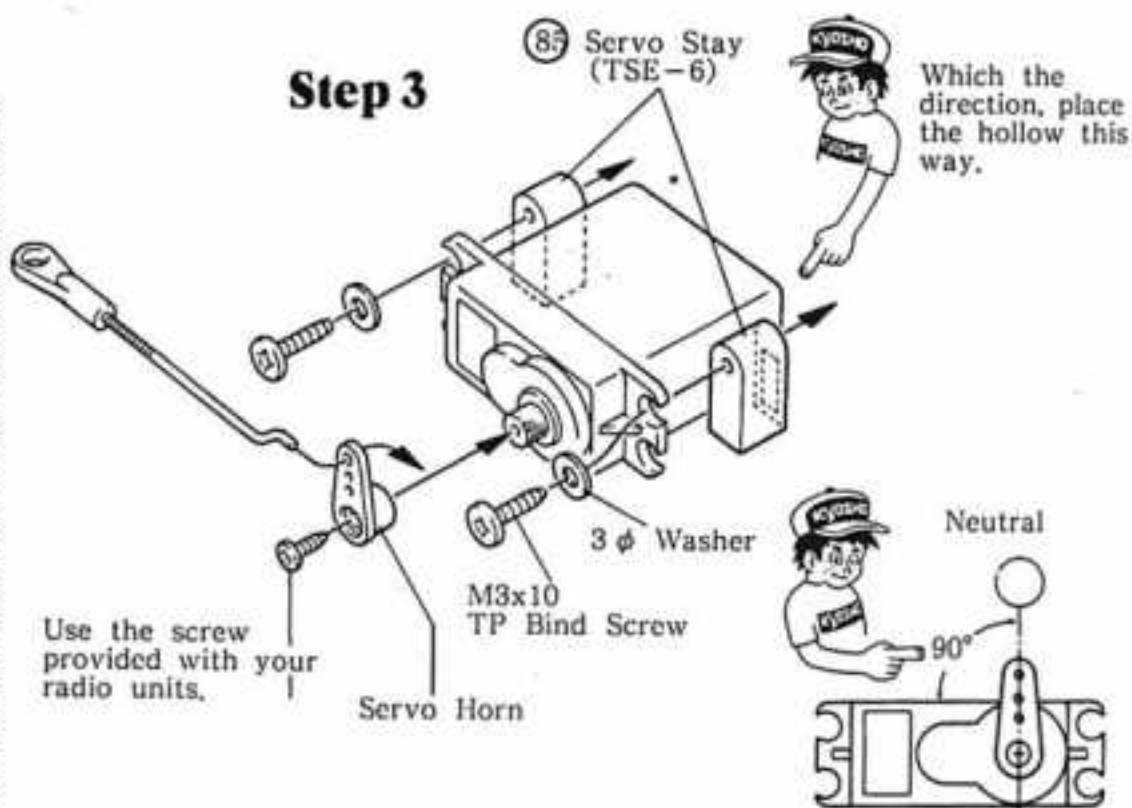

24 INSTALLATION OF STEERING TIE ROD

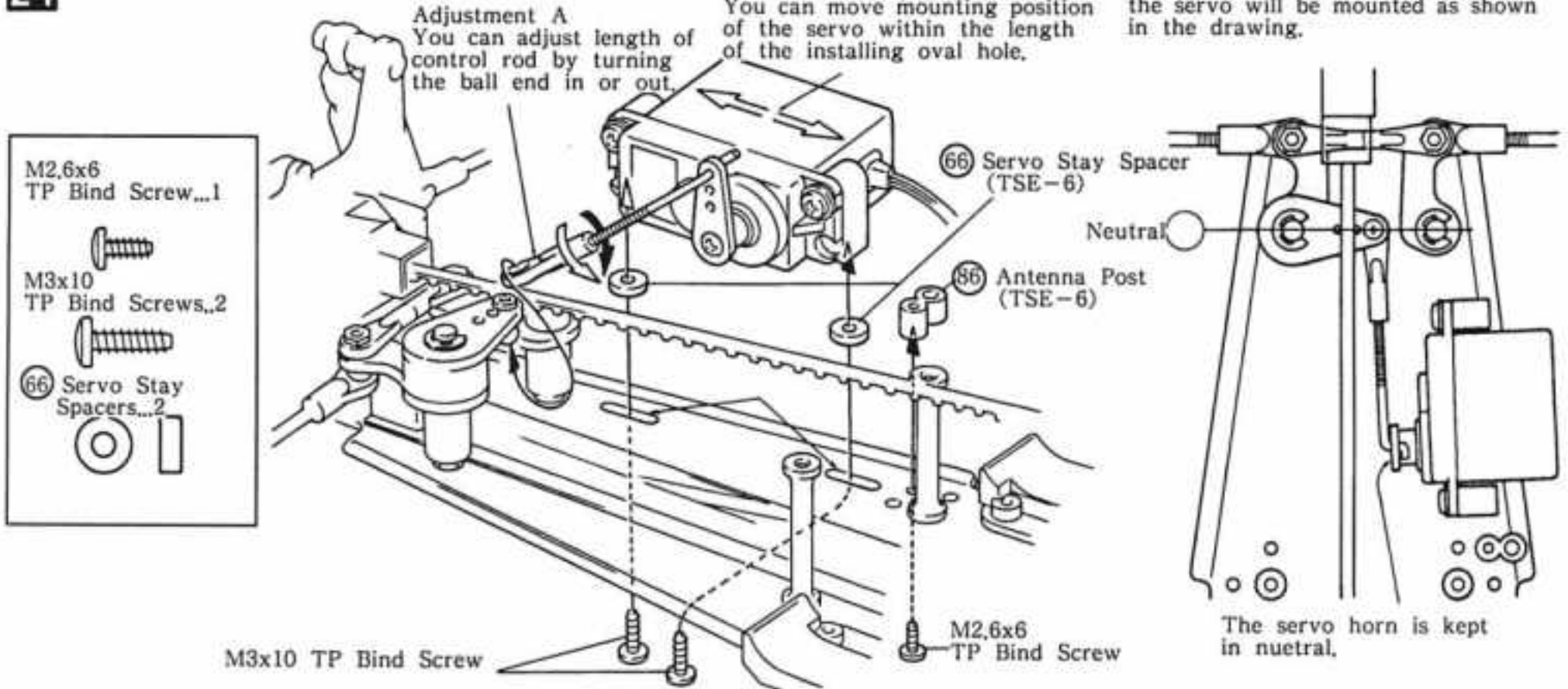

25 INSTALLATION OF UPPER DECK

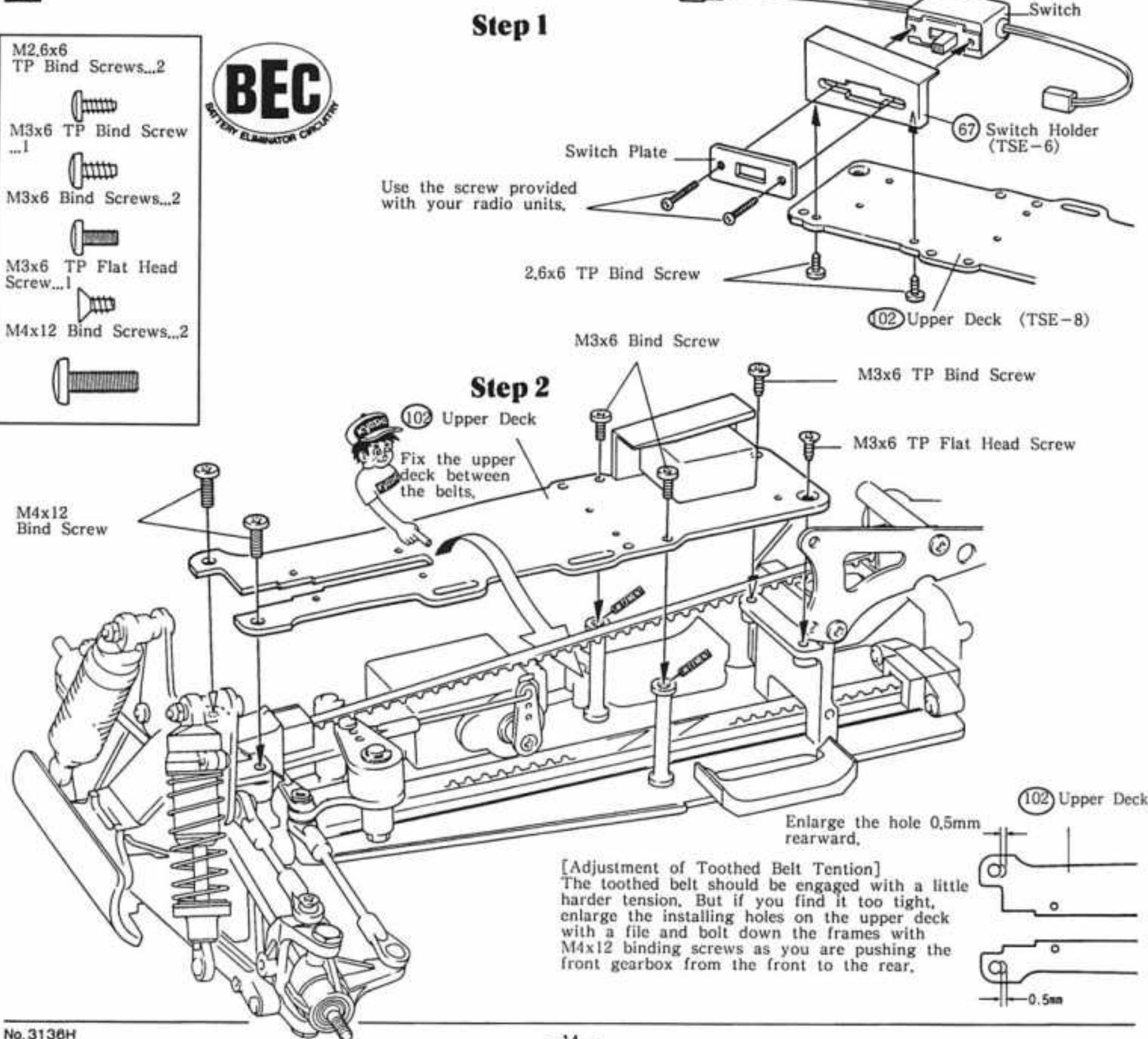

26 INSTALLATION OF BELT COVER (B) (C)

Cut off the shaded area along with the cutout line.

Step 1

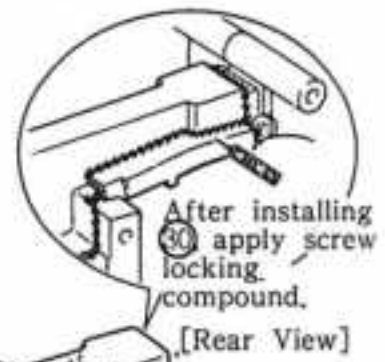
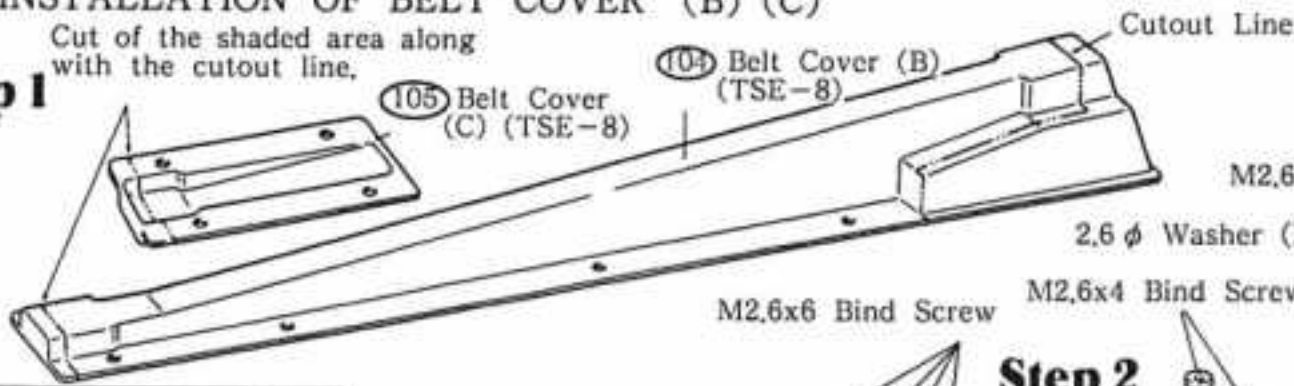

- M2.6x4 Bind Screws...4
- M2.6x6 Bind Screws...4
- 2.6 φ Washers...4
- M2.6 Nuts...4

Step 3

After installing the belt cover, apply screw locking compound along the obliquely lined edges (both sides) as done in step 8.

[Installation of Belt Cover (C)]

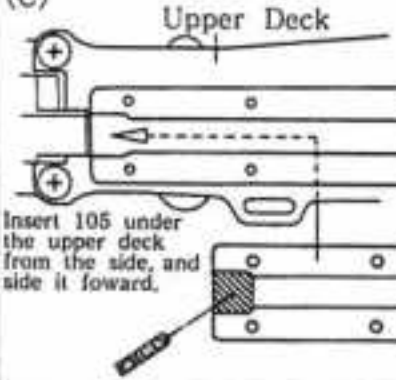

(This area will contact the outlet part of the gearbox.)

Step 2

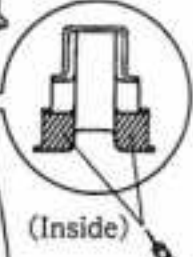
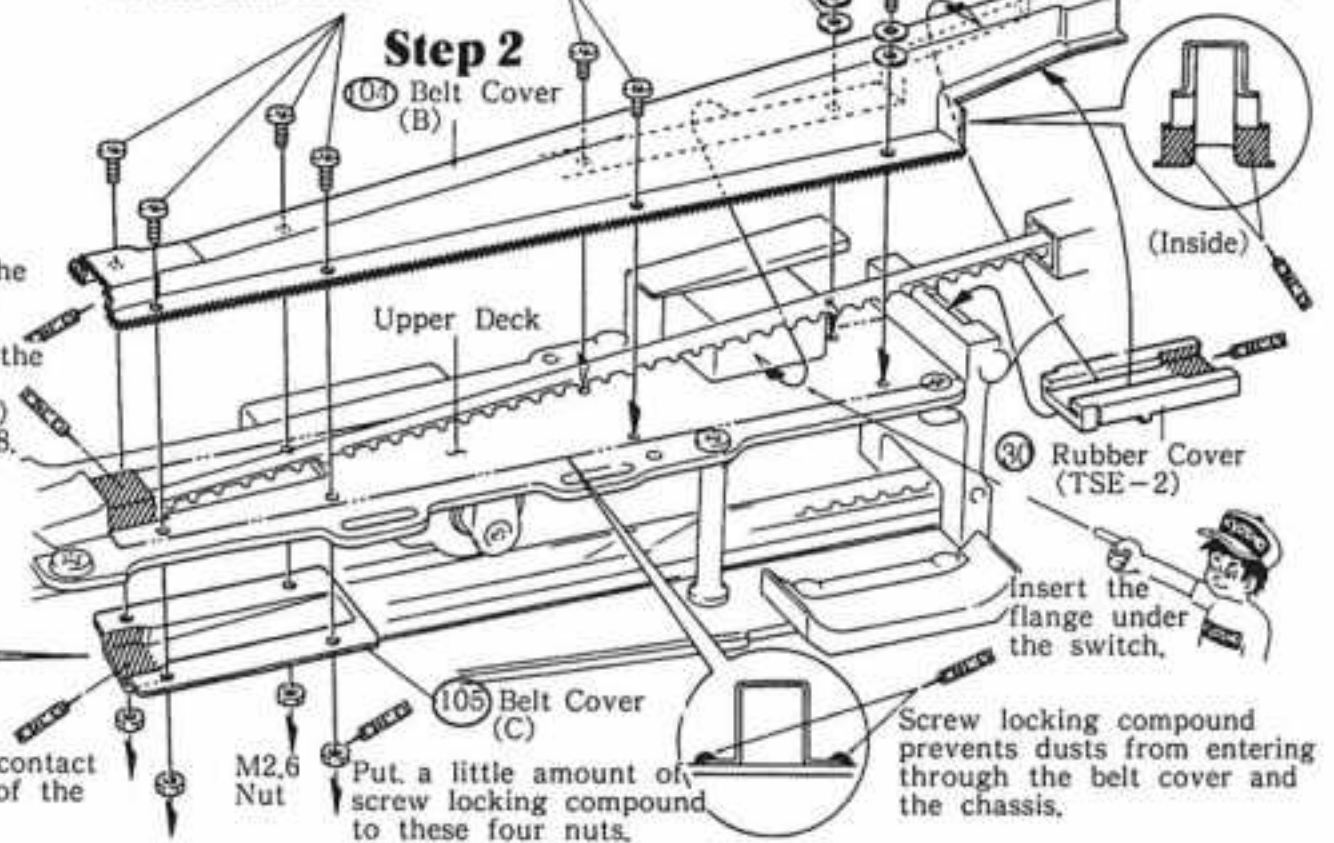

30 Rubber Cover (TSE-2)

Insert the flange under the switch.

Screw locking compound prevents dusts from entering through the belt cover and the chassis.

27 CHECKING THE BELT COVER

Dust is apt enter through a gap, no matter how small it is, along the seam of the belt cover. The dust may cause such troubles as damaging the belt or the gear teeth or a failure in power transmission. Check again to see if the seam and a thread are filled with locking agent completely.

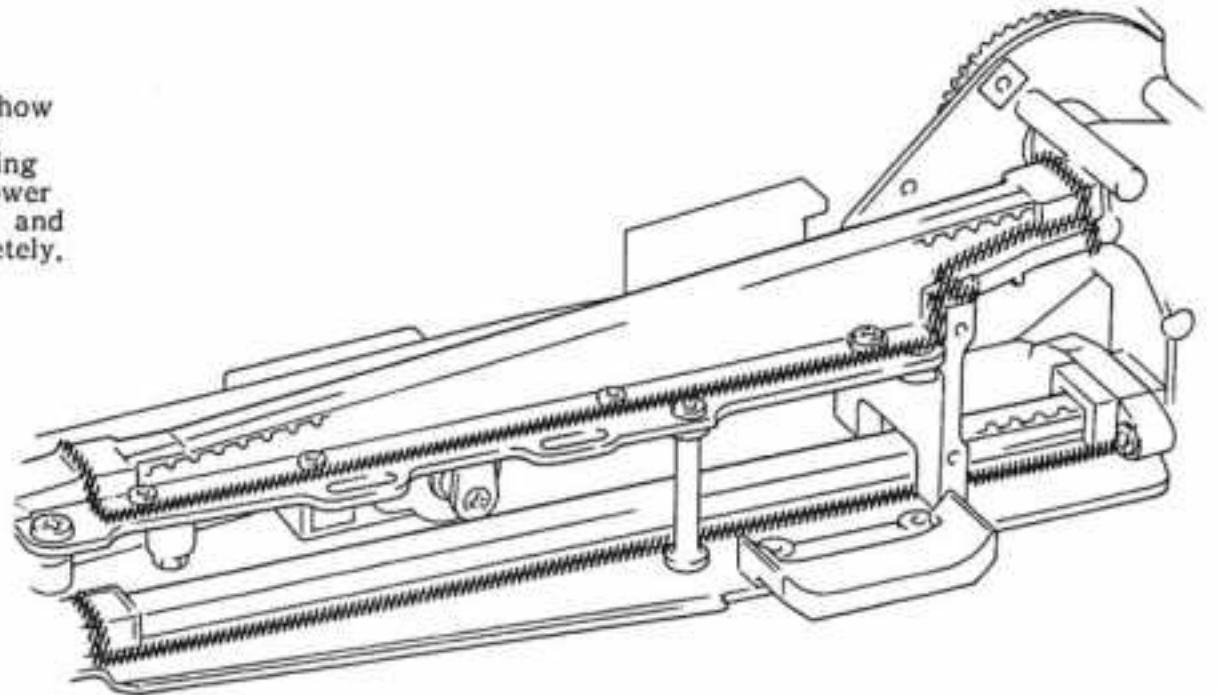

28 INSTALLATION OF MOTOR

Step 1

Set the setscrew to the flat on the shaft.

- M3x4 Round head Screws...2
- M3x10 Bind Screws...2
- M3x3 Set Screw...1

Once remove the upper part of the shock.

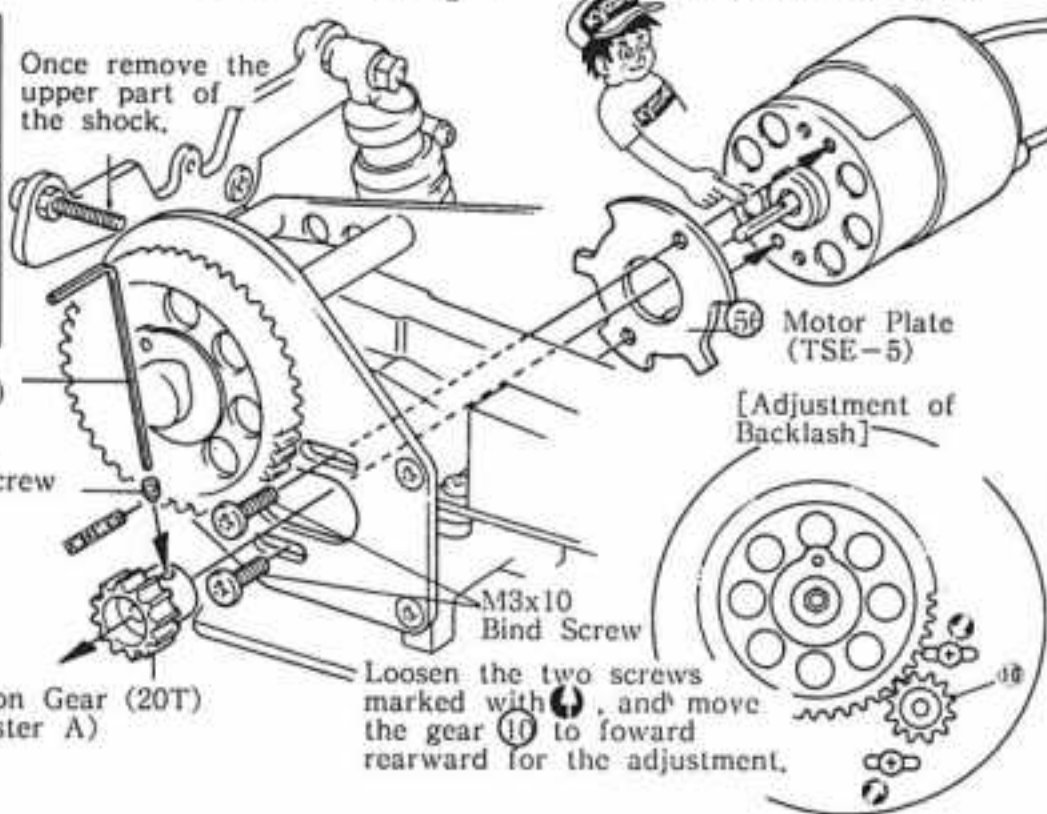

55 Motor Plate (TSE-5)

[Adjustment of Backlash]

133 Hex Key (1.5mm) (TSE-1)

M3x3 Set Screw

Approx. 13mm

10 Pinion Gear (20T) (Blister A)

Step 2

After installing 106 fix the shock as it was before. Cut off the striped area before fixing it.

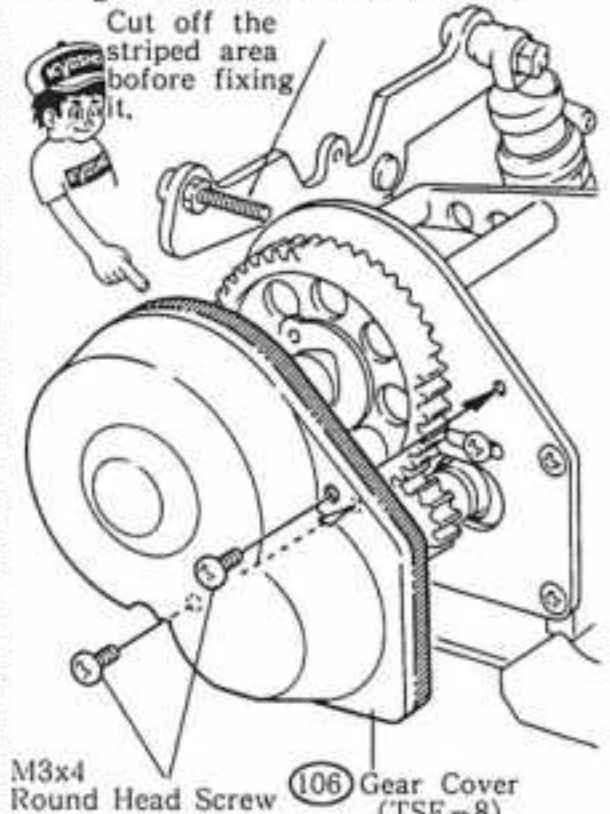

M3x4 Round Head Screw

106 Gear Cover (TSE-8)

29 INSTALLATION OF SPEED CONTROL AND RESISTOR

- M2x8 TP Screw...1
- M3x6 Bind Screw...1
- M3x10 Round Head Screw...2
- 4.8 φ Ball...1
- M3 Nuts...2
- Heat Sink Collar...1

Step 1

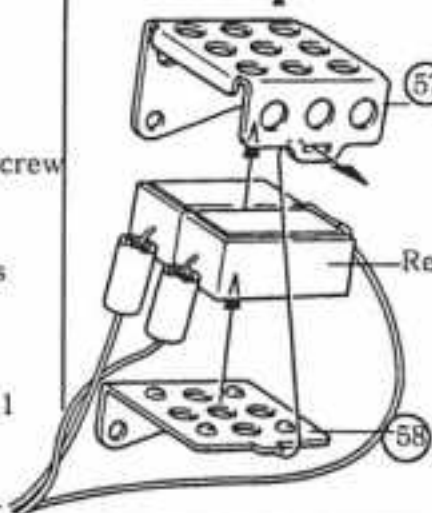

Step 2

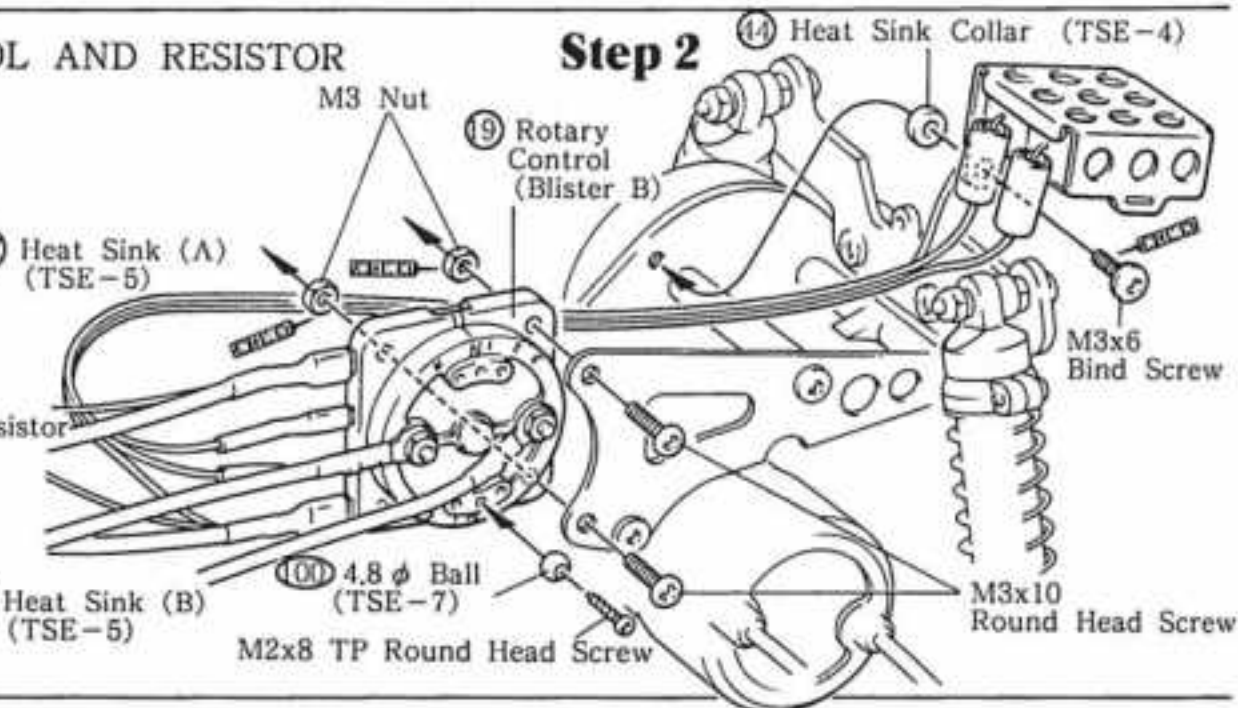

30 INSTALLATION OF SPEED CONTROL SERVO

- M3x10 TP Bind Screws...4
- 3 φ Washers...2

Step 1

Trimming of servo horn.
Enlarge this hole so that the control rod can be fitted easily in the next step.

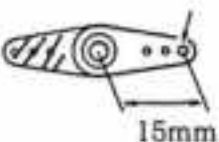

This servo spacer will not be used when a small servo is mounted.

Step 2

Be careful about the direction.

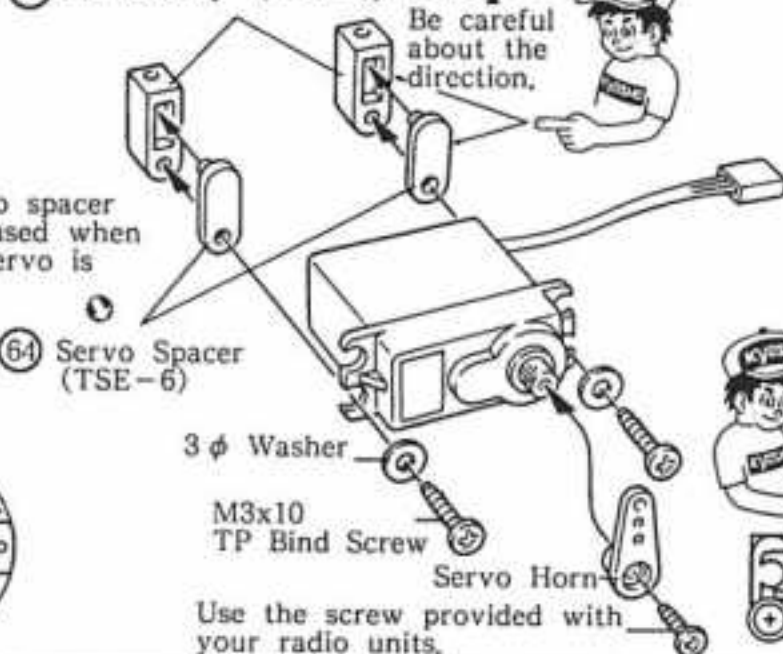

Step 3

M3x10 TP Bind Screw

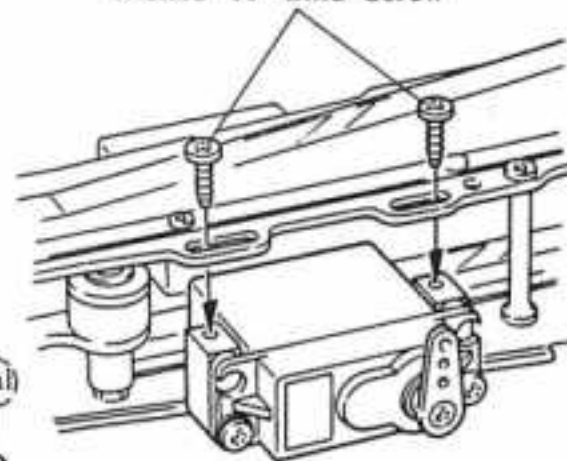

31 SPEED CONTROL LINKAGE

- Ball End (S)...1

Step 1

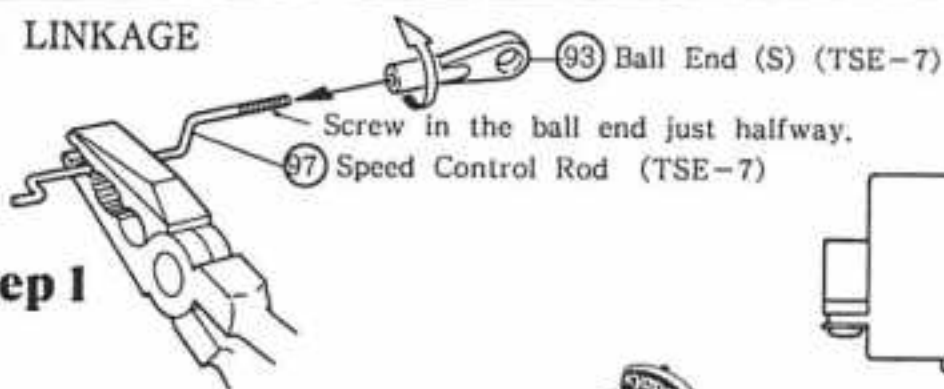

Adjust **A** and **B** so that the relationship among the components will be arranged as shown below.

The lines should be aligned in the neutral position.

Step 2

Plug in red to red and white to black.

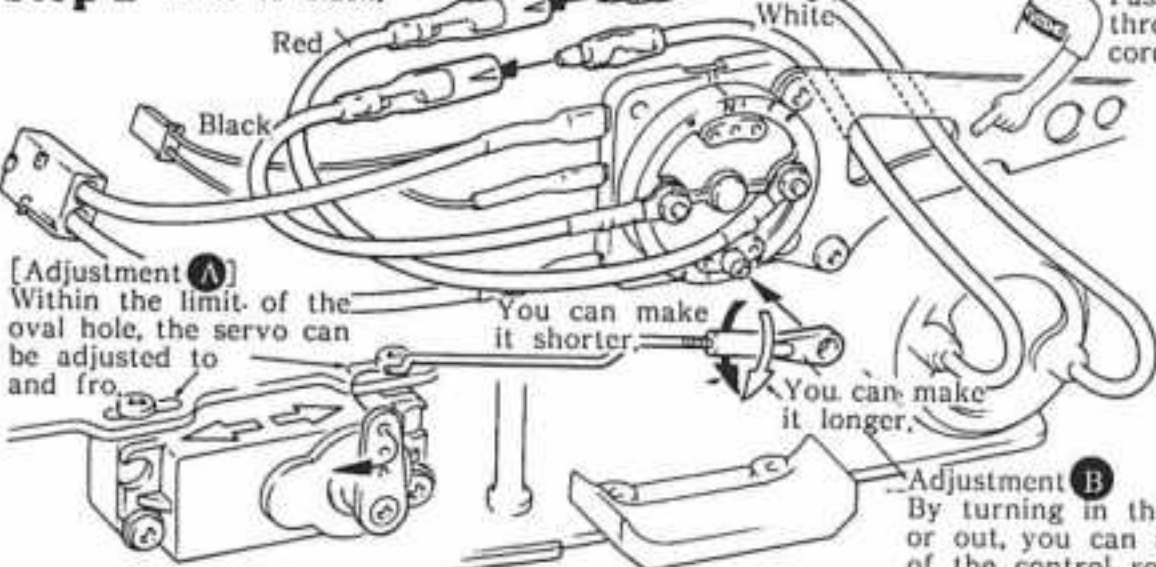

[Adjustment **A**]
Within the limit of the oval hole, the servo can be adjusted to and fro.

You can make it shorter.

You can make it longer.

Adjustment **B**
By turning in the ball end in or out, you can adjust the length of the control rod.

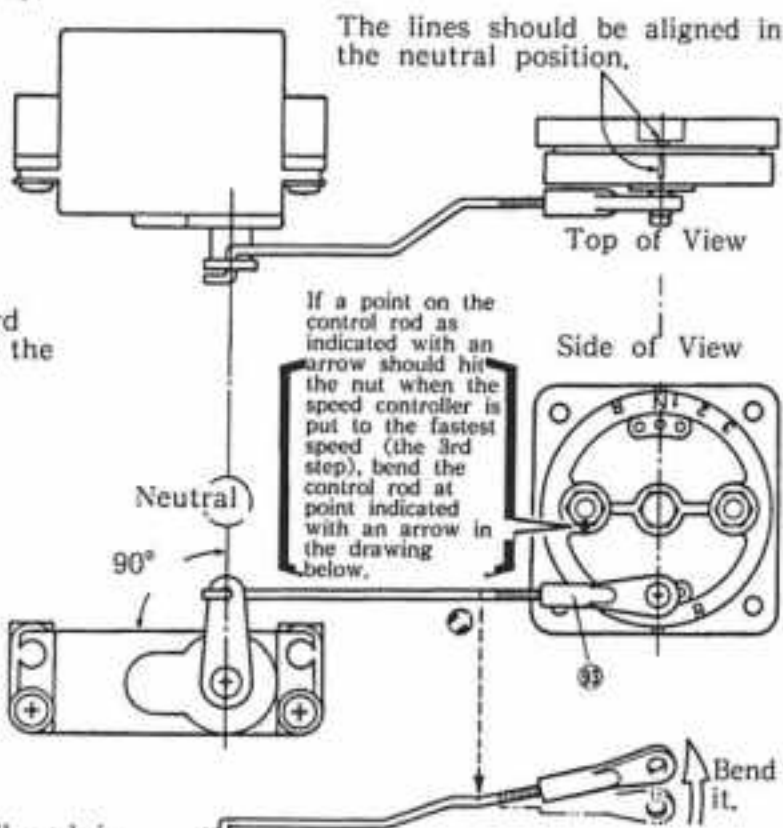

MOVEMENT OF THE SPEED CONTROLLER

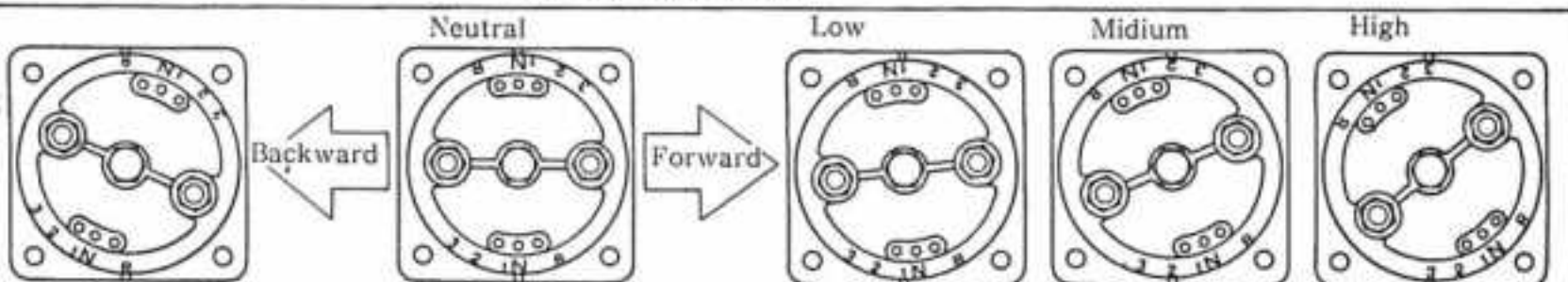

32 INSTALLATION OF RECEIVER

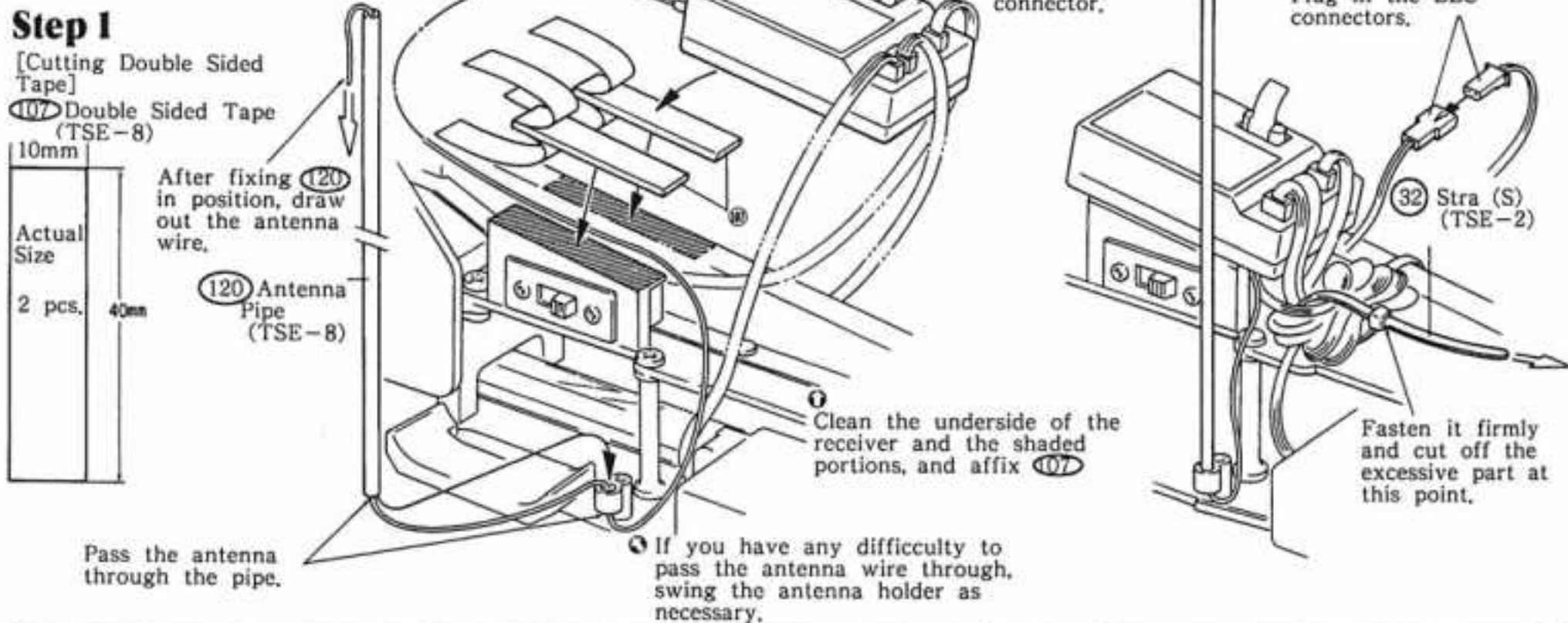

33 INSTALLATION OF WING STAY *All the parts, except screws, used in this step are packed in (OPM-6).

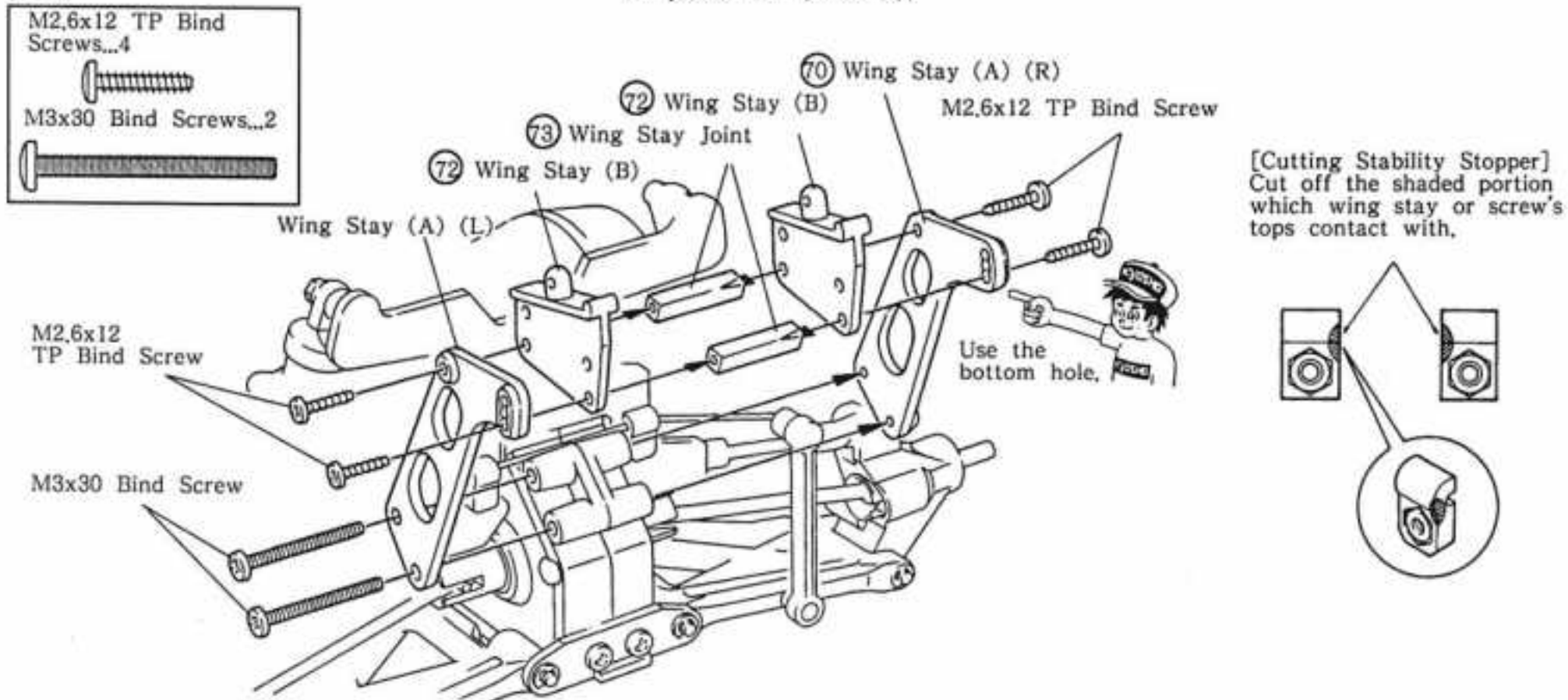

34 ASSEMBLY OF TIRE AND WHEEL

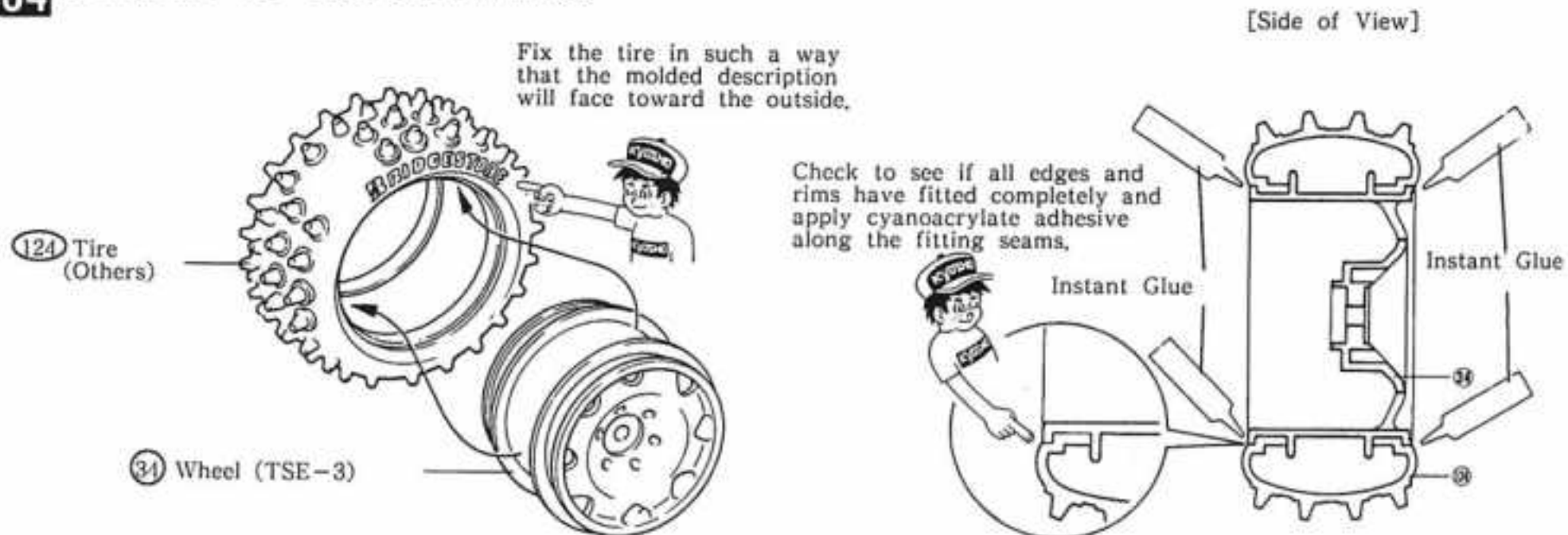

35 INSTALLATION OF TIRE

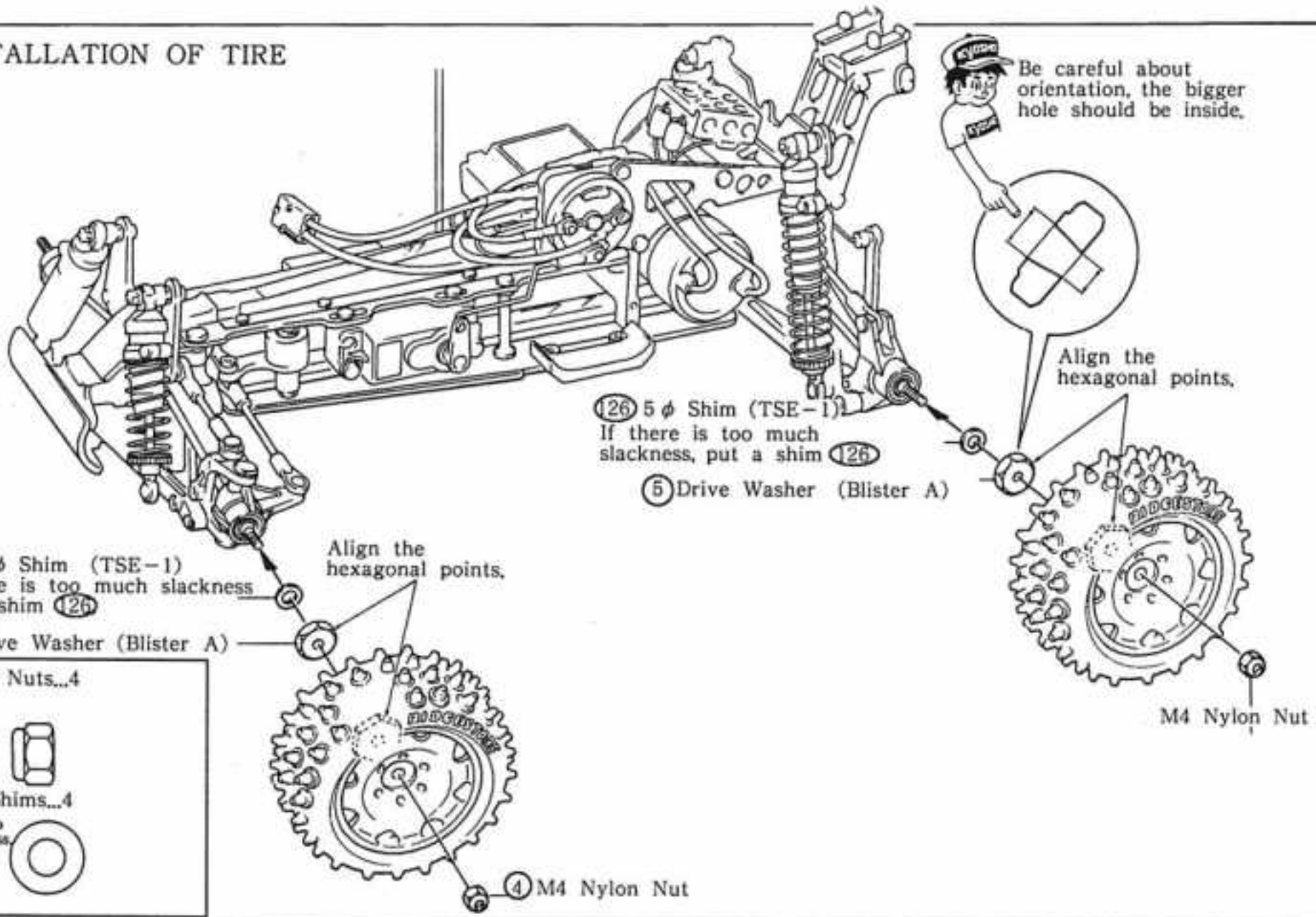

36 CUTTING OF BODY AND WING

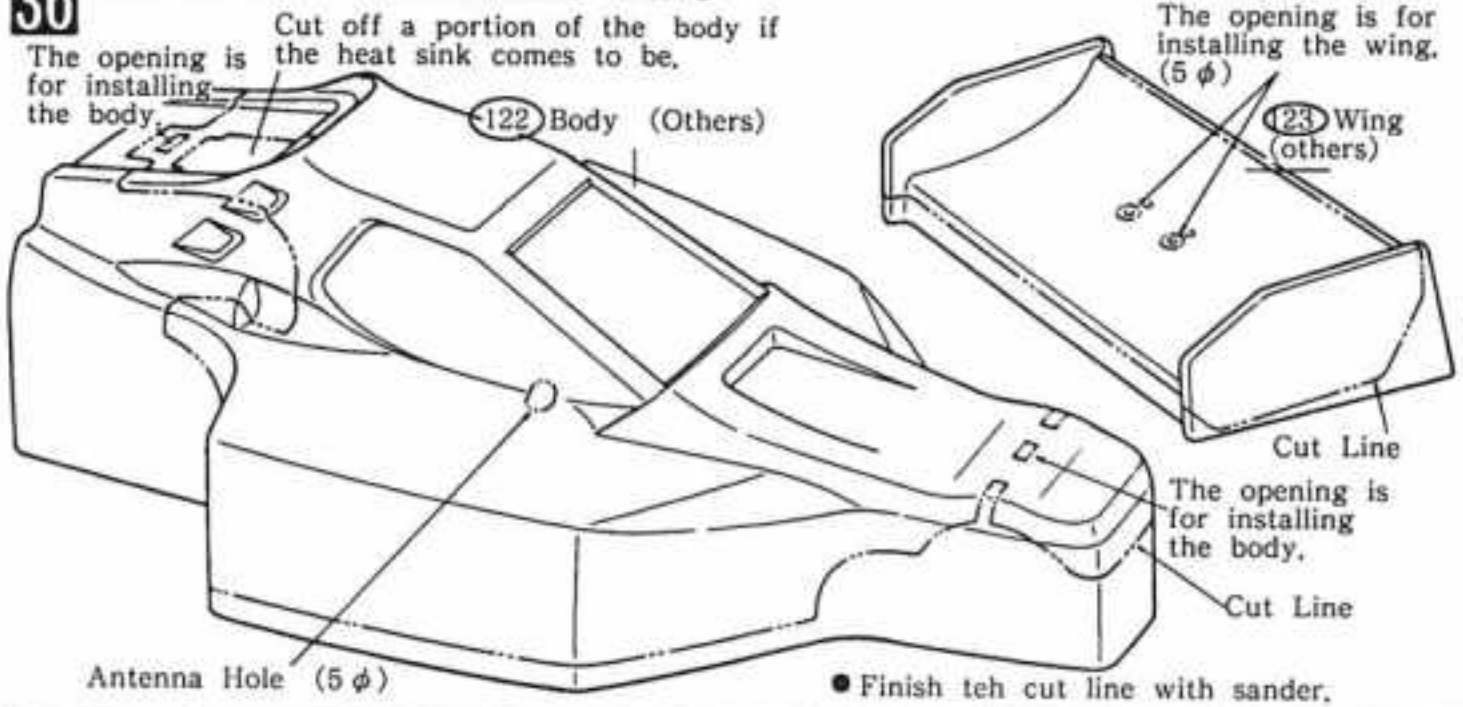

KYOSHO No.1829

These special Lexan Scissors make trimming bodies a breeze and the sander comes in handy for finishing the rough edges.

Sander

37 PAINTING

First, wash the body to remove any oil or dirt. Rinse thoroughly. Paint the inside of the body. You can obtain a color scheme by masking a portion with tape then remove the tape and painting. Apply the lightest color last.

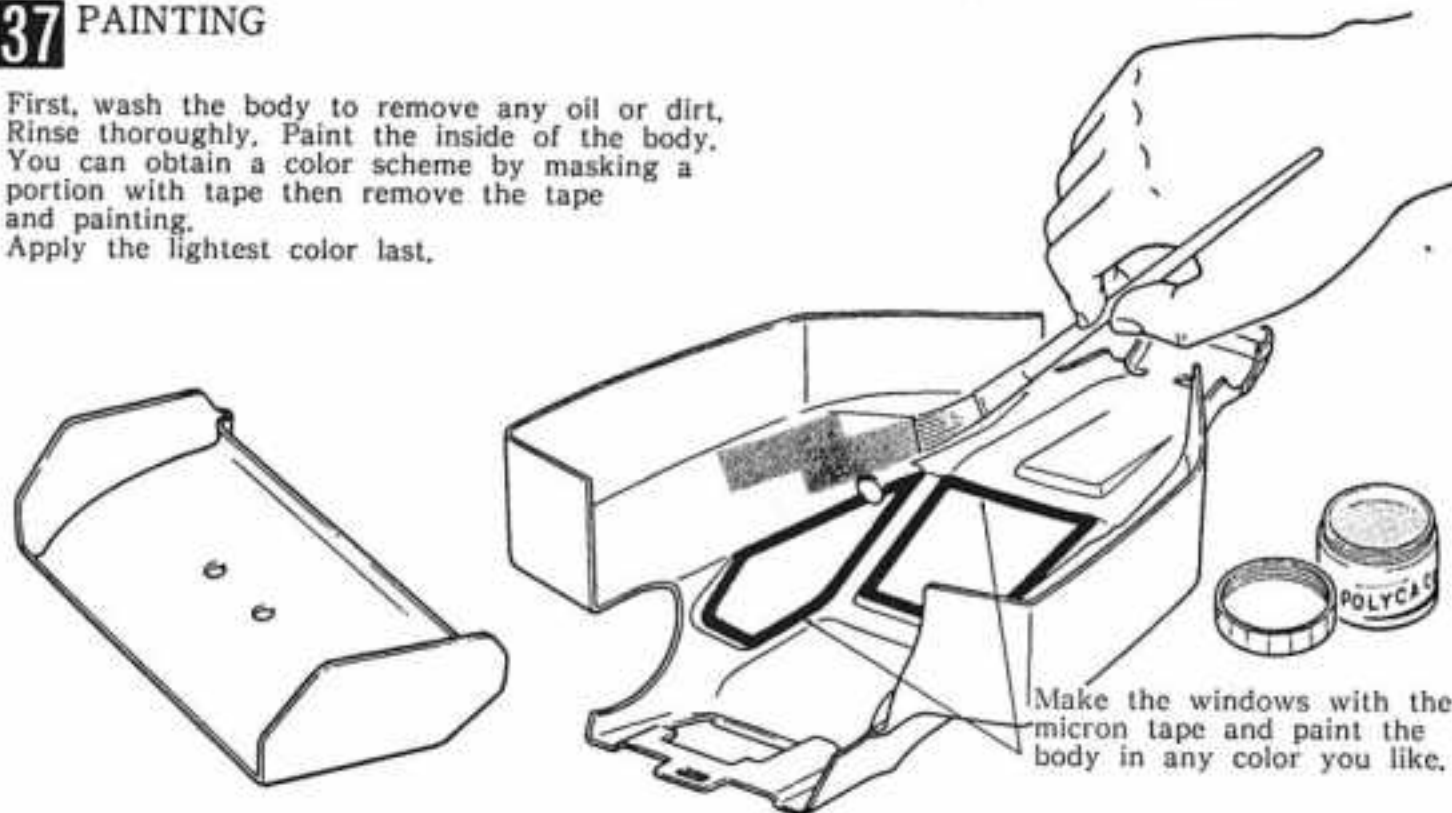

KYOSHO

Micron Line Tape

No.1841...1.0 mm
No.1842...1.5mm
No.1843...2.5mm

Color
White, Red
Yellow, Green
Blue & Black

KYOSHO

Polica Color No.2230

White, Red, Yellow, Green, Blue, Skyblue, Orange, Black, Violet, F. Pink, Yellow Green, F. Orange.

38 APPLY DECALS

[Hints for Applying Decals]

- Cut off the decals along the cutout line with scissors.
- Do not apply it abruptly. Convince yourself of the position by trying the decals with the backing paper on.
- Be careful not to have air bubbles left. Try to smooth out the decal's surface from the center to the periphery. (Particularly be cautious with a large decal.)

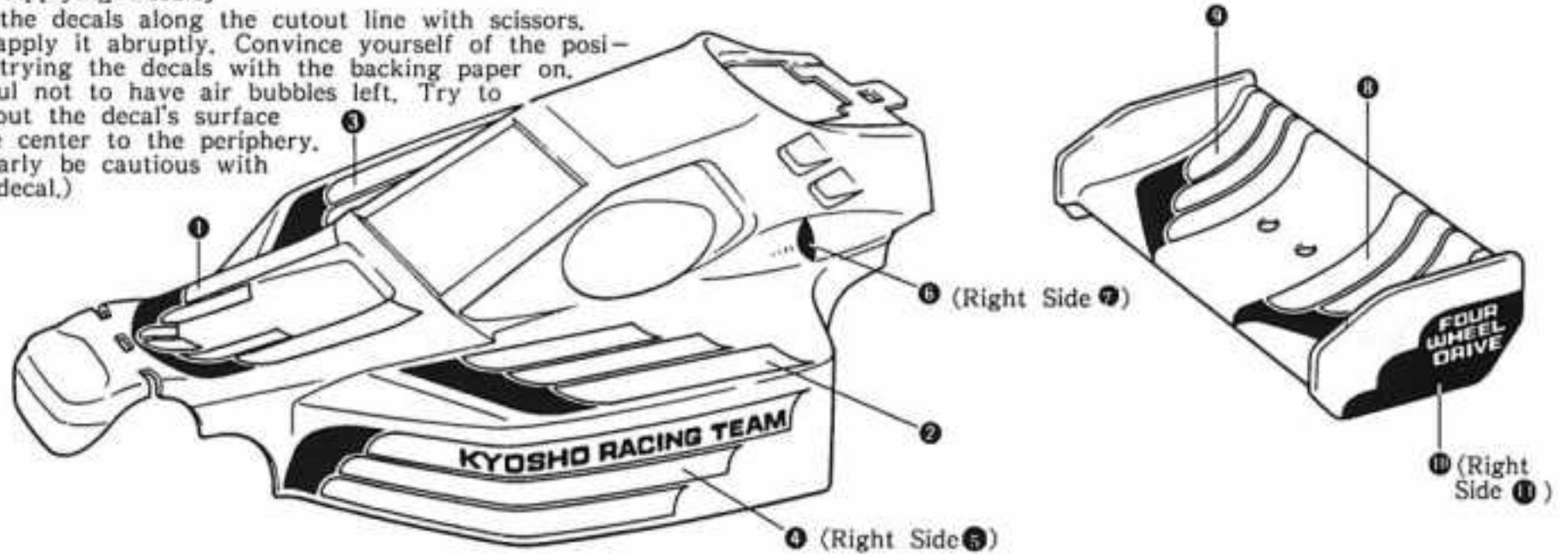

39 MOUNTING OF BATTERY

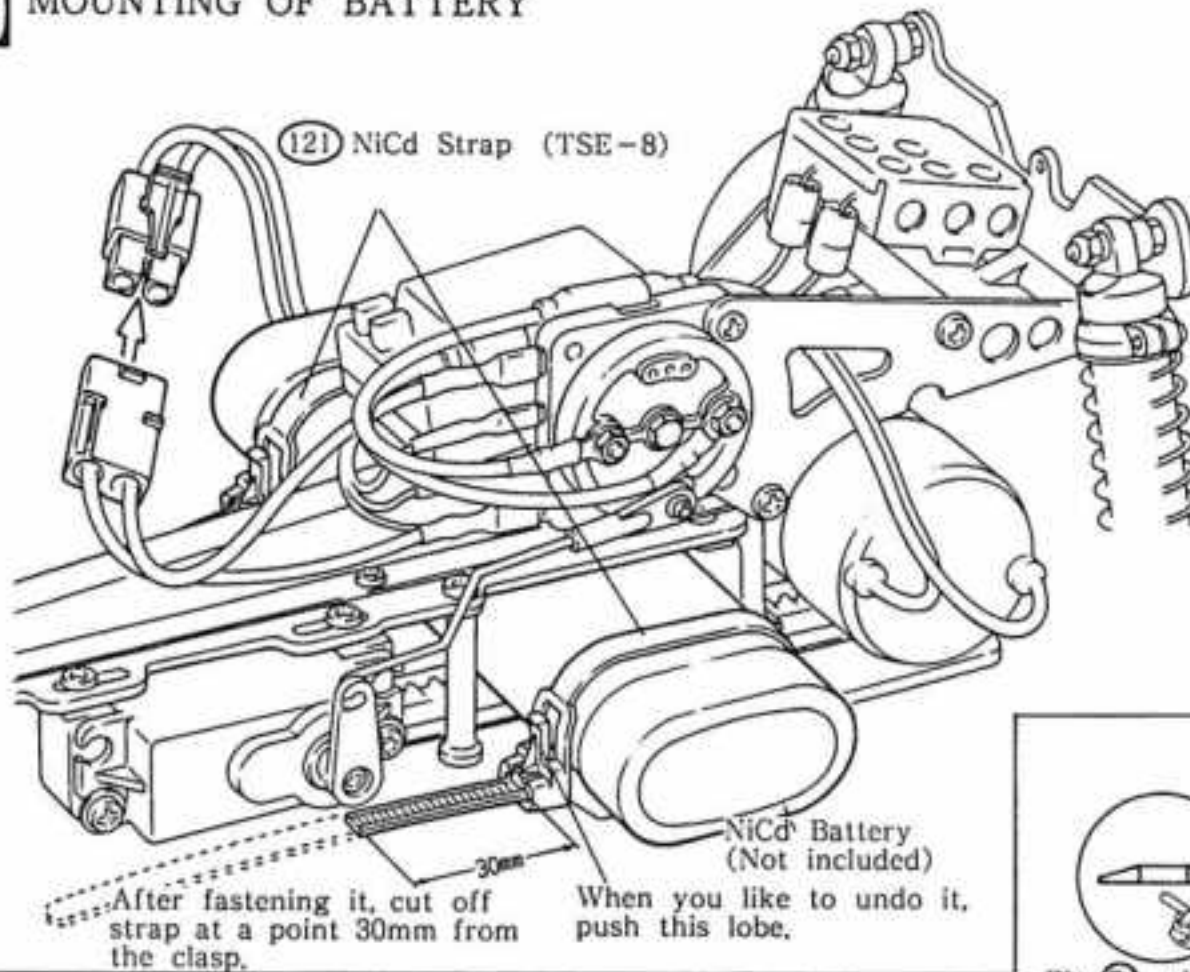

KYOSHO

Select a high performance NiCd battery pack which is powerful enough to drive a model buggy car vigorously. Kyosho offers the 7.2V Sprint Battery SCR which is prepared for the buggy car specially.



When you have your car stored or not running, keep the battery pack dismantled.

40 INSTALLATION OF BODY AND WING

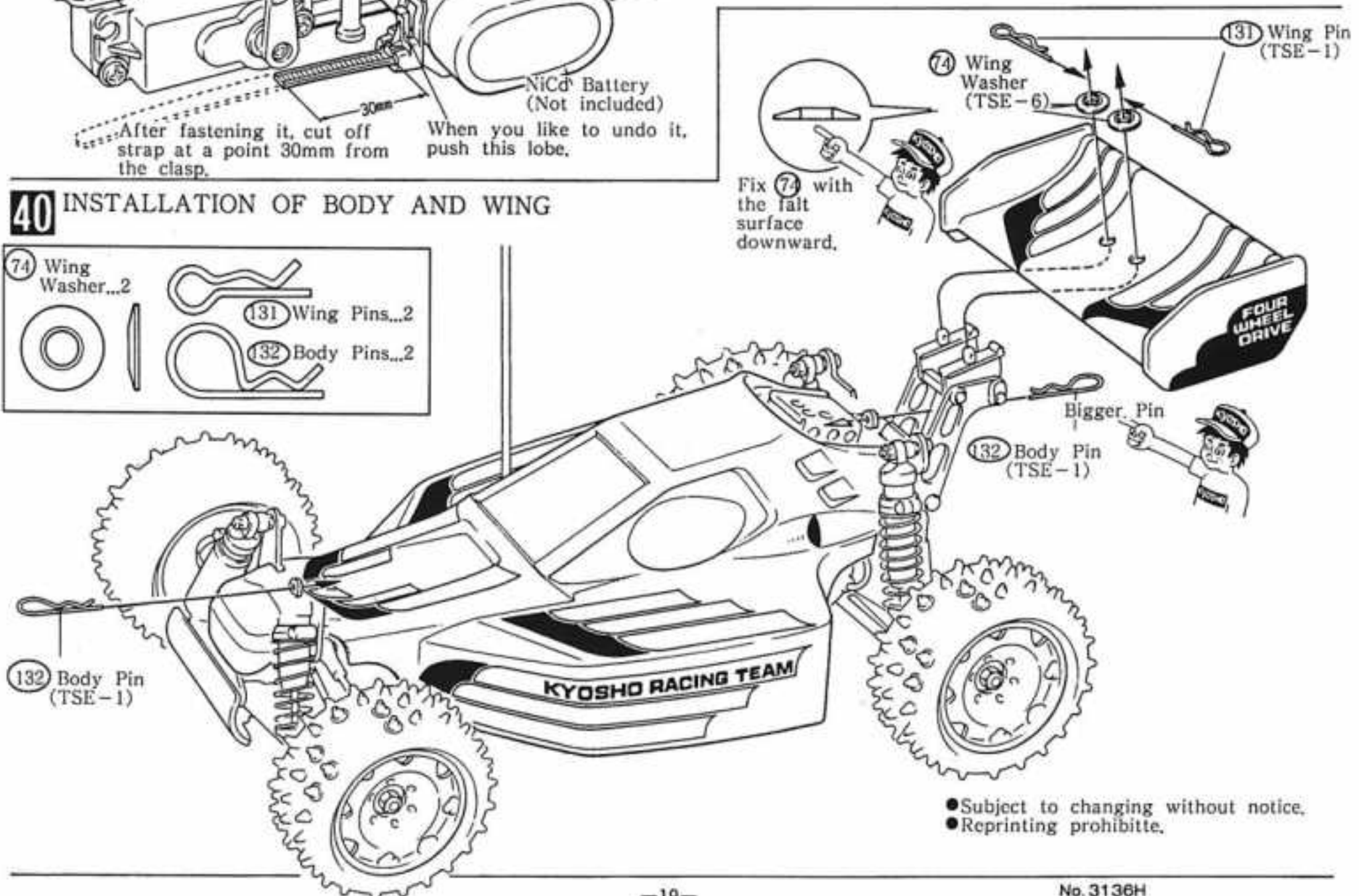
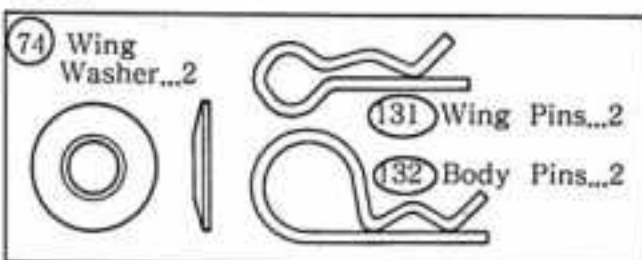

- Subject to changing without notice.
- Reprinting prohibitte.

[Adjustment of Ball Differential Gear After Assembly]

The ball differential was adjusted before installing it into the gearbox in step 3 on page 5. Now check to see if the cap screw is tightened properly by the following ways. First remove the gear cover, and put a small piece of sponge or cardboard paper between the main gear and the pinion gear in order to lock the gear.

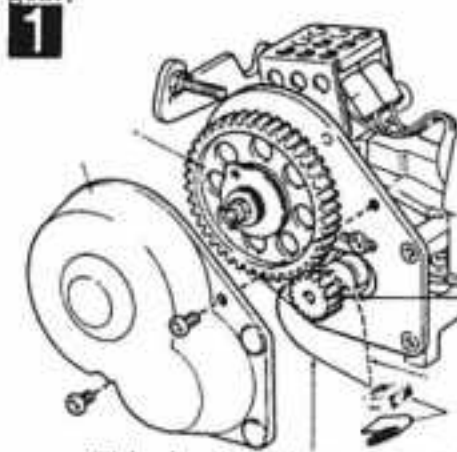

*Be careful that, depending upon the front or rear differential gear, the place to put the pawl is different.

The following drawings from 2 to 4, are showing the way for the front differential gear, but apply the same way to the rear one.

Pinion Gear

use a piece of sponge or thick paper when testing the front differential gear.

This is the place to put a pawl for the rear differential adjustment

1 Lift up the model by holding the wheels with both hands.

Check the rear differential with battery pack mounted.

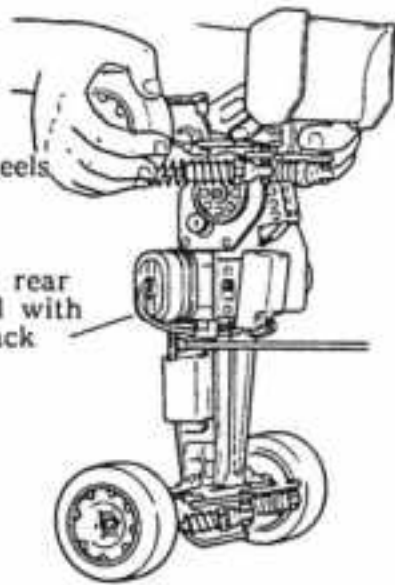

2 Swing up the model slowly by holding the rear wheels. If it will not go more than 45°, the model is adjusted in the best condition.

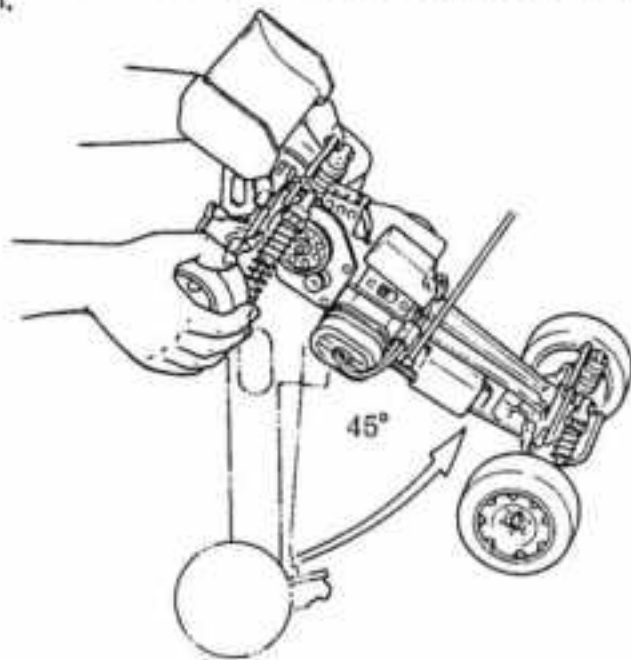

3 If it goes up more than 45°, it would show excessive tightening of the cap screw. If less than 45°, it would require to tighten it more. In such cases, remove the binding screw which fastens the rear hub, and adjust it as shown in the drawing.

*While adjusting it using an hex key, hold the right-side wheel with your hand.



When testing the front differential, remove the battery pack from the model.

the fitting point of the pawl is on the opposite from the case of adjusting the rear differential. Upon testing the steps 2 and 3, hold the front wheels and swing the model 45° up. In step 4 in the case of removing the front hub, take off the M3x12 flat head screw.

[Basic Setting]

Place the model car on a flat surface, and keep the car with the maximum body clearance, and adjust length of the front and rear upper rods so that the wheels stand at a right angle to the ground.

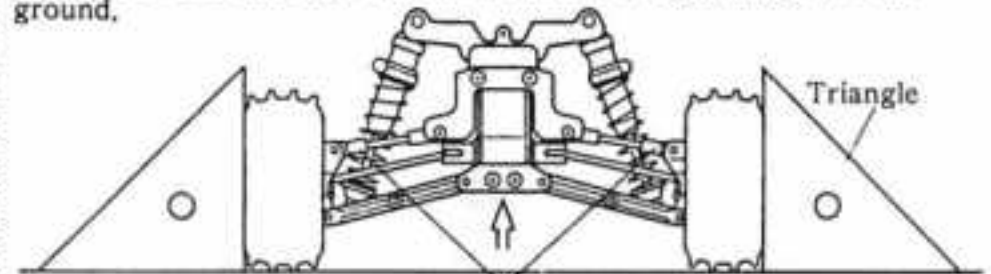

● By adjusting the upper rod shorter, you will have a trait of negative camber. With negative camber adjustment on the front wheels, you will have sharper steering tendency, while on the rear wheel, the gripping power becomes higher.

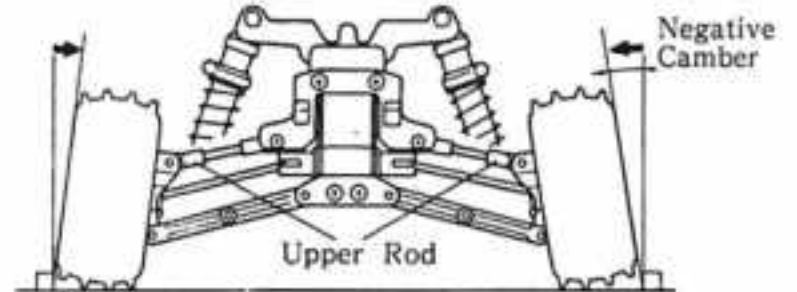

● By lengthening the upper rod, positive camber adjustment is gained. With positive camber on the front wheels, you will have a trait of under steering, while on the rear wheels you will have the car with over steering traits.

*Excessive positive camber adjustment may make the swing shaft dislocated.

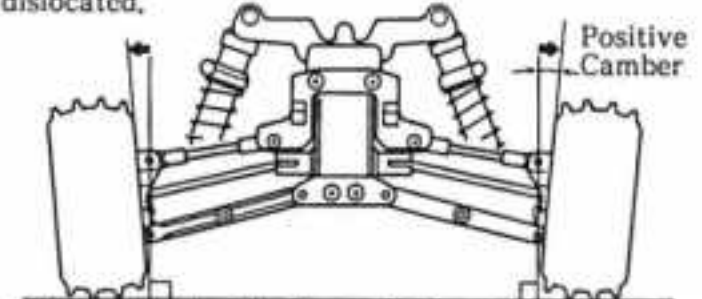

[Correlation between the Position of Front Upper Rod and Camber Angle]

The installing points A, B, and C on the front shock stay for the upper rod correspond to A', B' and C' which are the maximum camber angle when the front suspension arms swing down to the lowest position.

Front Shock Stay

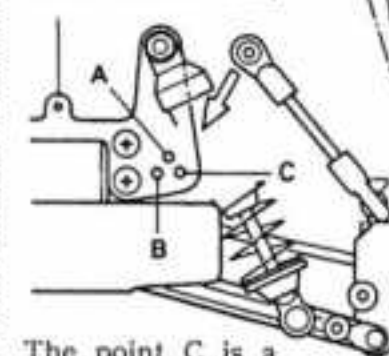

The point C is a normal position.

The various lengths of the upper rod.

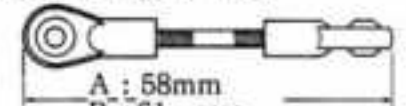

A : 58mm
B : 61 mm
C : 55 mm

Adjust the length of the upper rod depending upon the installing point.

[Correlation between installing position of the Rear/ Upper Rod and Camber Angle]

The installing points A and B on the upper rod plate will result in the positions of the rear camber angle A' and B' when the rear suspension arms sink the most.

Rear Upper Plate

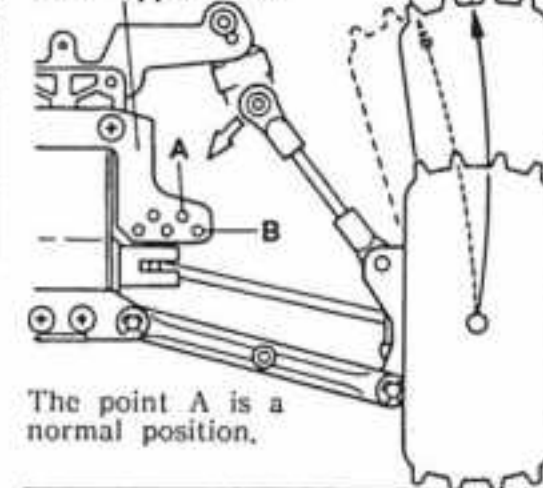

The point A is a normal position.



A : 58,5mm
B : 54,5mm

Adjust the length of the upper rod depending upon the installing point.

[Adjustment of Shock Oil and Spring]

- Front (With lighter shock oil) → Quicker steering response
- Front (With less spring tension) → Quicker steering response
- Front (With heavier shock oil) → Slower steering response
- Front (With more spring tension) → Slower steering response
- Rear (With lighter shock oil) → More traction
- Rear (With less spring tension) → More traction
- Rear (With heavier shock oil) → Less traction
- Rear (With more spring tension) → Less traction

[Adjustment of Suspension Spring]

There are two ways of the adjustment, ① and ②

- ① Adjusting it with the spring stopper.
- ② Adjusting it with the spring spacer.

Leave the clearance of 5mm to 10mm here.

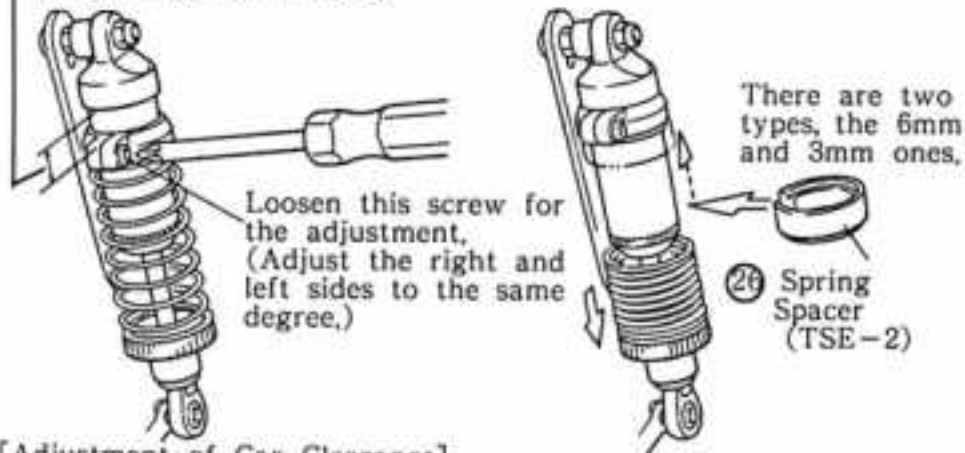

[Adjustment of Car Clearance]

Adjust it with the binding screw.

(1) Adjustment of front clearance

- Installing position for lower clearance (This is the position as shown in the instruction.)
- For higher clearance... Use the lower hole.

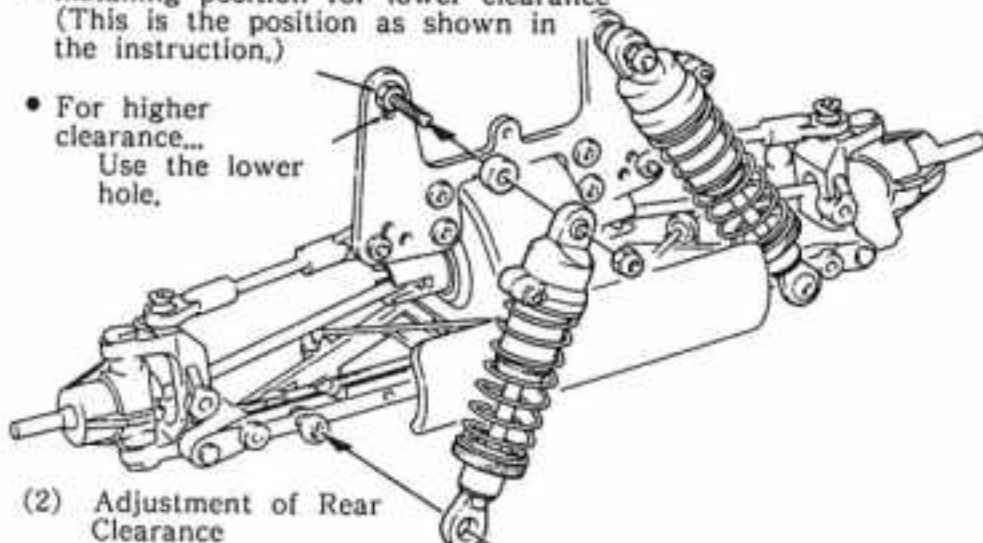

(2) Adjustment of Rear Clearance

- Installing position for lower clearance (This is the position as shown in the instruction.)
- Installing position for higher clearance.

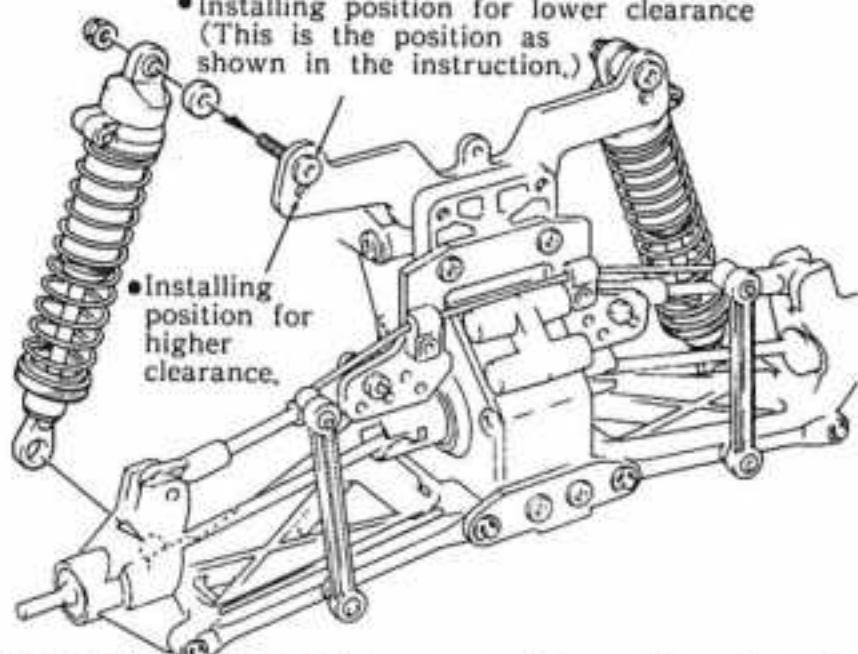

* You can adjust the car clearance as shown above depending upon the conditions of a running course. Generally speaking, low clearance for turf or anywhere that gives you a good traction, and high clearance for a poor traction.

[Relation between Gear Ratio and Motor]

Pinion Gear	15	16	17	18	19	20	21	22	23	24	25
Gear Ratio	13.04	12.22	11.50	10.87	10.29	9.78	9.31	8.89	8.50	8.15	7.82
Compatible Motor	SPA 240WS										
	Le Mans H240S										
	Le Mans 240ST										
	Le Mans 3600LD										

[Modification of Tire]

By changing the shape of the knobs on the tire, you can improve the running performance of the car.

* If your car displays the quick steering response, but off the knobs by 1/2 to 1/3 then you can make it with milder response.

Lets the knobs down.

Type of Course Surface	Amount of Lowering Knob
Turf	Cut 1/2
Concrete	Cut 2/3
Sandy	No Cutting
Hard Dirt Track	Cut 1/3
Soft Dirt Track	No Cutting

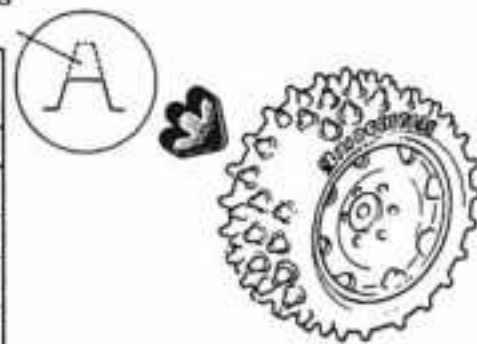

* In the "Option House" series, the 5031 Low Profile Tire (for surface) and the W5032 Low Profile Tire (for soft surface) are available.

[Maintenance of Differential Gears]

Check the part of the differential frequently when the cocked belt is engaged. If you find any dust, remove it.

[Checking inside of rear box]

The following illustration shows the necessary parts to take off and the steps for checking the inside of the gearbox.

Step 1

Remove the screws and E-rings marked in red color.

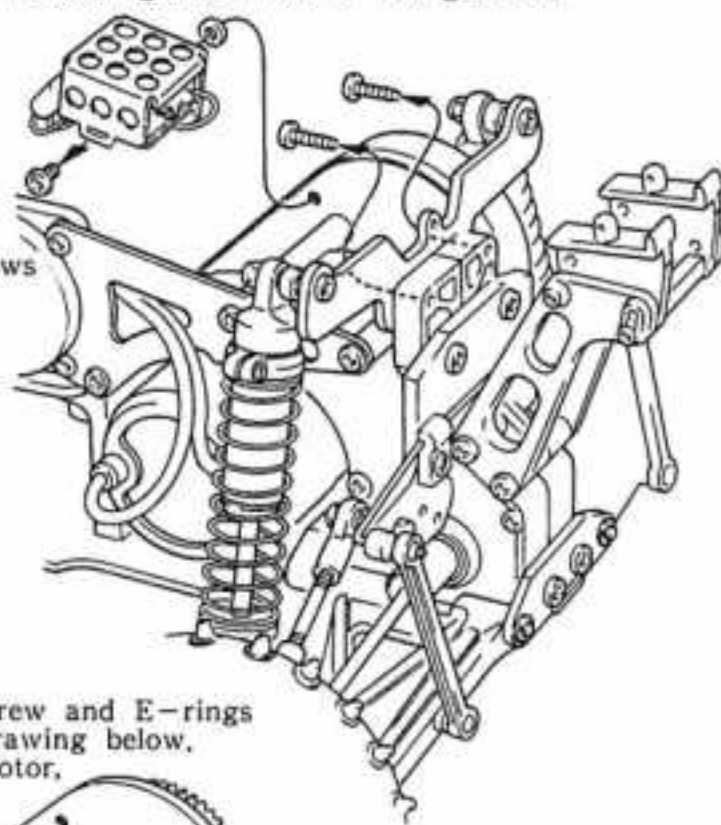

Step 2

Take off the screw and E-rings shown in the drawing below. Dismount the motor, too.

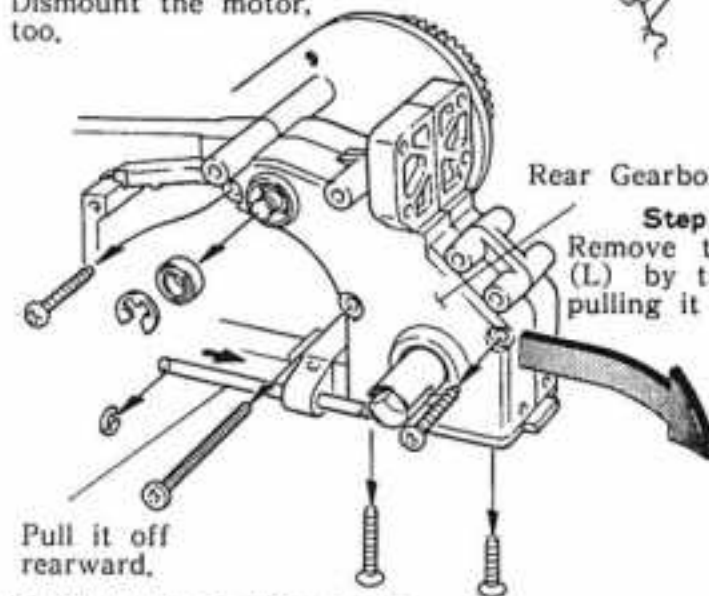

Rear Gearbox (L)

Step 3

Remove the rear gearbox (L) by turning it left as pulling it rearward.

Pull it off rearward.

[Adjustment of wing stay]

When assembling the wing stay (B) to the wing stay (A), fastening the part to the position A will place the wing stay (B) to A', B to B', and C to C'; that is, the installation angle becomes bigger in order, A → B → C.

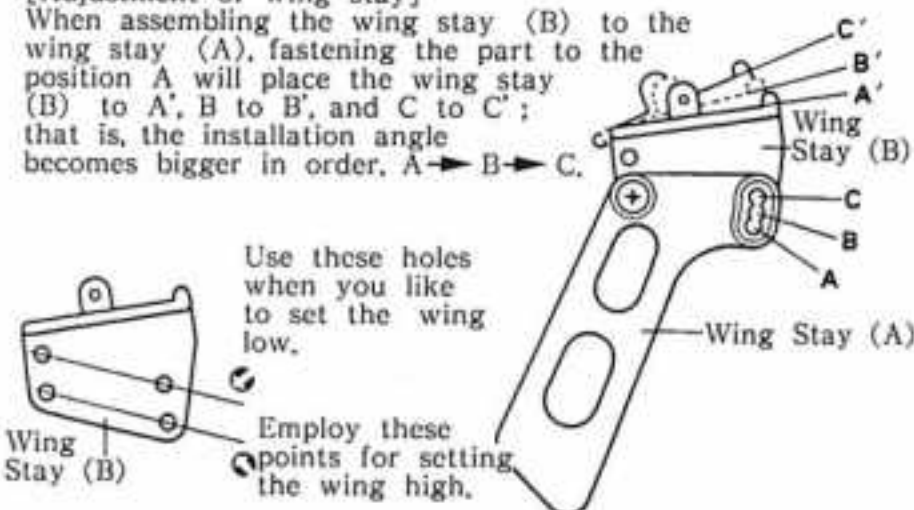

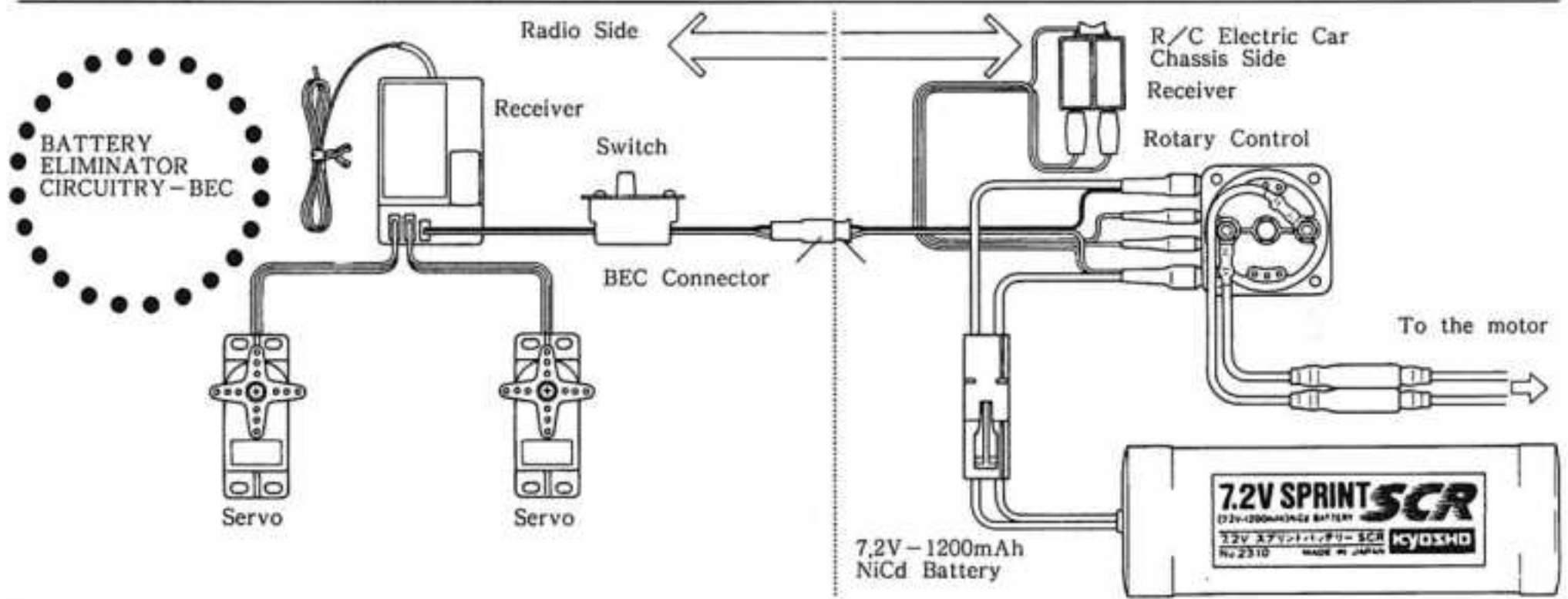

PARTS LIST

Key #	Parts Name	Q'ty	Key #	Parts Name	Q'ty	Key #	Parts Name	Q'ty	[Ball Differential]	Q'ty	
①	Main Gear	1	④⑧	Upper Deck Post	2	⑨①	5 φ Ball (Silver)	Ball 4	Ⓐ	Diff. Shaft (B)	2
②	Center Gear	1	④⑦	Swing Shaft	2	⑨②	End (L)	12	Ⓑ	8 φ x14 Bearing	4
③	Toothed Belt	1	④⑧	Rear Plate (R)	1	⑨③	Ball End (S)	4	Ⓒ	Pressure Plate	4
④	Main Gear Pinion	1	④⑨	Rear Plate (L)	1	⑨④	Sus. Shaft (C)	2	Ⓓ	Diff. Ball	20
⑤	Drive Washer	4	⑤⑩	Front Shock Stay	1	⑨⑤	Sus. Shaft (D)	2	Ⓔ	Diff. Ring	2
●⑥	Front Ball Diff. Gear	1	⑤①	Rear Shock Stay	1	⑨⑥	Steering Rod	1	Ⓕ	Diff. Shaft (A)	2
●⑦	Rear Ball Diff. Gear	1	⑤②	Rear Upper Plate	1	⑨⑦	Speed Control Rod	1	Ⓖ	Thrust Washer	4
●⑧	Front Adjustable Shock	2	⑤③	Rear Sus. Plate	1	⑨⑧	Tie Rod	2	Ⓖ	Thrust Ball	16
●⑨	Rear Adjustable Shock	2	⑤④	Front Sus. Plate	1	⑨⑨	Upper Rod	4	Ⓚ	Tape Washer	10
⑩	Pinion Gear (20T)	1	⑤⑤	Gear Protector Plate (A)	1	⑩①	4.8 φ Ball	3	Ⓛ	M2.6x15 Cap Screw	2
⑪	4 φ x8 Bearing	2	⑤⑥	Motor Plate	1	⑩②	Main Chassis	1	★Ⓜ	Diff. Body (For Front)	1
⑫	5 φ x8 Bearing	2	⑤⑦	Heat Sink (A)	1	⑩③	Upper Deck	1	★Ⓨ	Diff. Body (For Rear)	1
⑬	5 φ x10 Bearing	10	⑤⑧	Heat Sink (B)	1	⑩④	Belt Cover (A)	1	★Ⓩ	Collar	1
⑭	Knuckle Arm (R)	1	⑤⑨	Pully (Yellow)	1	⑩⑤	Belt Cover (B)	1	★ⓐ	Holder Ring	1
⑮	Knuckle Arm (L)	1	⑤⑩	Pully Flange (Yellow)	1	⑩⑥	Belt Cover (C)	1			
⑯	Universal Swing Shaft	2	⑤⑪	5 φ Collar (L) (Yellow)	1	⑩⑦	Gear Cover	1			
⑰	Rear Wheel Shaft	2	⑤⑫	5 φ Collar (S) (Yellow)	2	⑩⑧	Double Sided Tape	1			
⑱	Le Mans 240ST Motor	1	⑤⑬	Battery Holder	2	⑩⑨	Motor Cleaner	1			
⑲	Rotary Controller	1	⑤⑭	Servo Spacer	2	⑩⑩	Motor Cover	1			
⑳	Front Gearbox (R)	1	⑤⑮	Front Stabilizer End	2	⑩⑪	Motor Cord (Red,White)	1 set			
㉑	Front Gearbox (L)	1	⑤⑯	Servo Stay Spacer	2	⑩⑫	Front Sus. Arm	2			
㉒	Rear Gearbox (R)	1	⑤⑰	Switch Holder	1	⑩⑬	Rear Sus. Arm	2			
㉓	Rear Gearbox (L)	1	⑤⑱	Rear Sus. Pivot	1	⑩⑭	Stabilizer Link	2			
㉔	Shock Oil	1	⑤⑲	Upper Deck Mount	1	⑩⑮	Stabilizer Stopper	2			
▲㉕	Shock Collar	4	⑤⑳	Wing Stay (A) (R)	1	⑩⑯	Stabilizer	1			
▲㉖	Spring Spacer	4	⑤㉑	Wing Stay (L)	1	⑩⑰	Rear Stabilizer	1			
㉗	Silicon Grease	1	⑤㉒	Wing Stay (B)	2	⑩⑱	Stabilizer End Ball	2			
㉘	Screw Lock Cement	1	⑤㉓	Wing Stay Joint	2	⑩⑲	Stabilizer Pillow Ball	2			
㉙	Sponge Tape	2	⑤㉔	Wing Washer	2	⑩⑳	Sponge Cap	2			
㉚	Rubber Cover	1	⑤㉕	Bumper	1	⑩㉑	Antenna pipe	1			
㉛	One Touch Tape	2	⑤㉖	Front Hub (R)	1	⑩㉒	NiCd Strap	2			
㉜	Strap (S)	2	⑤㉗	Front Hub (L)	1	⑩㉓	Body	1			
㉝	Condenser	1	⑤㉘	Rear Hub (R)	1	⑩㉔	Wing	1			
㉞	Wheel	4	⑤㉙	Rear Hub (L)	1	⑩㉕	Tire	4			
㉟	Saver Shaft	2	⑤㉚	Servo Saver (A)	1	⑩㉖	Decal	1			
㊱	Main Gear Shaft	1	⑤㉛	Servo Saver (B)	1	⑩㉗	5 φ Shim	8			
㊲	Gear Protector Plate (B)	1	⑤㉜	Servo Saver (C)	1	⑩㉘	M2 Shaft	2			
㊳	Gear Protector Collar	1	⑤㉝	Servo Saver (D)	1	⑩㉙	E Ring (E2.5)	13			
㊴	Center Gear Shaft	1	⑤㉞	Servo Saver Collar	2	⑩㉚	E Ring (E3) (Black)	3			
㊵	Gear protector Washer	2	⑤㉟	Servo Stay	4	⑩㉛	E Ring (E4)	5			
㊶	King Pin	4	⑤㊱	Antenna Post	1	⑩㉜	Wing Pin	2			
㊷	5.8 φ Ball (Black)	4	⑤㊲	Sus. Shaft (A) (Silver)	2	⑩㉝	Body Pin	2			
㊸	2 φ x11 Pin	2	⑤㊳	Sus. Shaft (B) (Black)	2	⑩㉞	Hex Key (1.5mm)	1			
㊹	Heat Sink Collar	1	⑤㊴	M3 Pillow Ball (Silver)	4	⑩㉟	Hex Key (2mm)	1			
㊺	Ball Nut	3	⑤㊵	M2.6 Pillow Ball (Black)	4	⑩㊱	Wave Washer	3			

Mark ● assembling finished.
All parts except mark ★ are common for front and rear.
Mark ▲ contains two pieces of different thickness.

PURCHASING PARTS FOR YOUR KIT

You can purchase replacement and optional parts for your kit. All of the part identified by key number are usually not available singularly, but we offer these parts in convenient parts "packs" which can be purchased separately. To figure out which parts pack you need, find the key number for that

part within the manual. Then consult our parts pack guide below. When referring to the parts you need, always use the Parts Pack Number. For instance, if you need a King Pin (Key # 41) ask your dealer for Kyosho Parts Pack OT-4 (King Pin).

NO.	PART NAME	KEY NO. & Q'TY
OT-4	King Pin	41x4
OT-6	Swing Shaft	47x2
OT-16	Knuckle Arm	14,15x1
OT-18	Rear Shaft	17x2
OT-19	Drive Washer	5x4
OT-31	M3 Pillow Ball	89x10
OT-32	5.8 ϕ Ball	91x10
OT-33	Ball Nut M2,6	45x10
OT-35	Upper Rod Set	92x8 93,94x4
OT-36	M2,6 Pillow Ball	90x10
OT-38	Silicone Grease	27x2
OT-39	E Ring (2.5)	128x10
OT-45	Rear Hub	78,79x1
OT-55	Front Hub	76,77x1
OT-66	Low Profile Tire	124x2
OT-69	Sus Arm Set	111,112x2
OT-72	Heat sink for Resistor	44,57,58x1
OT-73	Motor Cleaner Set	56x1 108x2
OT-79	Motor Cord	110x2
OT-84	Gear Box	20,21,22,23x1
OT-85	Spur Gear	1,2x1
OT-86	Counter Gear	4x1
OT-87	Gear Shaft Set	36,39x1 43,127x2
OT-88	Protector Set	37,38,55x1 40x2 135x6
OT-89	Cogged Belt	3x1
OT-92	Upper Deck	46x2 102x1
OT-93	Bumper	75x1
OT-95	Plate set	48,53,54x1
OT-97	Sus. Shaft Set	87,88,94,95x2
OT-98	Battery Holder Set	67,68,69x1 63,64,65,66x2
OT-99	Wing Stay Set	70,71x1 72,73x2 74x4
OT-100	Collar Set	59,60,61x1 62x2
OT-101	5.8 ϕ Ball (Black)	42x10
OT-102	Belt Cover Set	103,104,105,106x1
OT-103	Tape Set	29,31x2 30x1
OT-105	Rod Set	96,97x1
OT-106	Body	122x1
OT-107	Wing	123x1
OT-113	Wheel (Silver)	34x4
OT-114	Rear Plate L.	49x1
OT-115	Decal	125x1
OT-116	Screw Set	Screw, Nut, Wrench
OTW-1	Stabilizer Set	100,113,114,117,118x2 115,116x1
OTW-2	Special Shock Stay	50,51,52x1
OTW-3	Special Chassis	35x2 101x1
W0107	Ball Diff. (Front)	1 set
W0108	Ball Diff. (Rear)	1 set
W5003	Adjustable Shock (S)	1 set
W5004	Adjustable Shock (L)	1 set
W5061	Universal Swing Shaft	16,126x2
1817	Rotary Controller	19x1
1840	Both Side Tape	107x1
1878	ScrewLockingCompound	28x2
1889	Body Pin	132x5
1901	5 ϕ x10 Bearing	13x2

NO.	PART NAME	KEY NO. & Q'TY
1902	5 ϕ x8 Bearing	12x2
1903	4 ϕ x8 Bearing	11x2
1911	8 ϕ x14 Bearing	Ball Diff. Bx2
SC-40	Motor Cover	109x1
SC-89	Tie Rod	98x2 90,92x4
EF-37	Strap S	32x6
EF-39	NiCd Strap	121x6
EP-22	Hook Pin	131x54
UM-14	Servo Saver Set	80,81,82,83,86x1 84x2 85x4
SD-79	Antenna Pipe	120x5
KC-20	E Ring (E-4)	130x4
CB-72	E Ring (E-3)	129x4
OPTIONAL PARTS		
OT-47	Front Hub Set	Low Caster Type
OT-67	Low Profile Wheel	3 pcs. Type x 2
OT-90	Low Profile Wheel	One pcs. Type x4
EF-103	Racing Wire	4 ϕ Silicone Cord
LM-15	Motor Cooling Plate	For Le Mans Motor
RK-15	Low Profile Tire	(Rear) x2
1863	Sponsor Sticker	Decal Sponsor Mark
1872	Sponge Tire B	For Low Profile Wheel
1883	Frontier Hobby Oil	30cc
1953	Silicon Oil (S)	Viscosity 100sc,200scx1 (Same as 1951S)
1954	Silicon Oil (M)	Viscosity 300sc,400scx1 (Same as 1951M)
1955	Silicon Oil (H)	Viscosity 500sc,600scx1 (Same as 1951H)
1990	Regulator	For Receiver
1951	Shock Oil Set (S,M,H)	Soft, Medium, Hard
W5001	Pressure Oil Shock (S)	12 ϕ
W5002	Pressure Oil Shock (L)	2 ϕ
W5005	Special Rod Set	One Touch Adjustable
W5021	Low Profile Wheel	Rear, Silver x2
W5022	Narrow Wheel	Silverx2
W5031	Low Profile Tire Hard	Hard Dirt (Rear)
W5032	Low Profile Tire Soft	Soft Dirt (Rear)
W5033	Narrow Tire Pin Type	Soft Dirt (Front)
W5034	Narrow Tire	Hard Dirt (Front)
W5085	Hard Pinion Gear	15T
W5086	"	16T
W5087	"	17T
W5088	"	18T
W5089	"	19T
W5090	"	20T
W5091	"	21T
W5092	"	22T
W5093	"	23T
W5094	"	24T
W5095	"	25T
WBD-1	Ball Diff. Gear Shaft Plate Set	A,F,M,N,x1 Cx2
WBD-2	Ball Diff. Gear Ball Set	D,Hx12 Gx2 Ix10 Jx1
WBD-3	Ball Diff. Gear	K,Lx1 Ex2

