

RADIO CONTROLLED ELECTRIC POWERED RACING BUGGY
4WD
OFF-ROAD RACER
TURBO OPTIMA

Radio 16

- WORLD'S FIRST BUGGY CUSTOM MADE FOR 8.4V POWER! POWER-MATCHED DESIGN!
- EXCITING, CHAMPIONSHIP-WINNING PERFORMANCE!
- SUPER PERFORMANCE WITH 8.4V BATTERY AND LeMANS 240S MOTOR!
- FOUR WHEEL DRIVE FOR MAXIMUM TRACTION AND CORNERING!
- EXTRA-LONG FRONT AND REAR DOUBLE-WISHBONE SUSPENSION FOR LONG WHEEL MINIMUM BUMP STEERING, MAXIMUM SHOCK ABSORPTION!
- HIGH-STRENGTH COMPONENTS, ENGINEERED FOR HIGH SPEEDS!
- TOP-QUALITY MATERIALS AND DESIGN! A SURE WINNER!

1:10 SCALE

BATTERY: 8.4V-1200mAh
RADIO: 2ch.
(NOT INCLUDED)

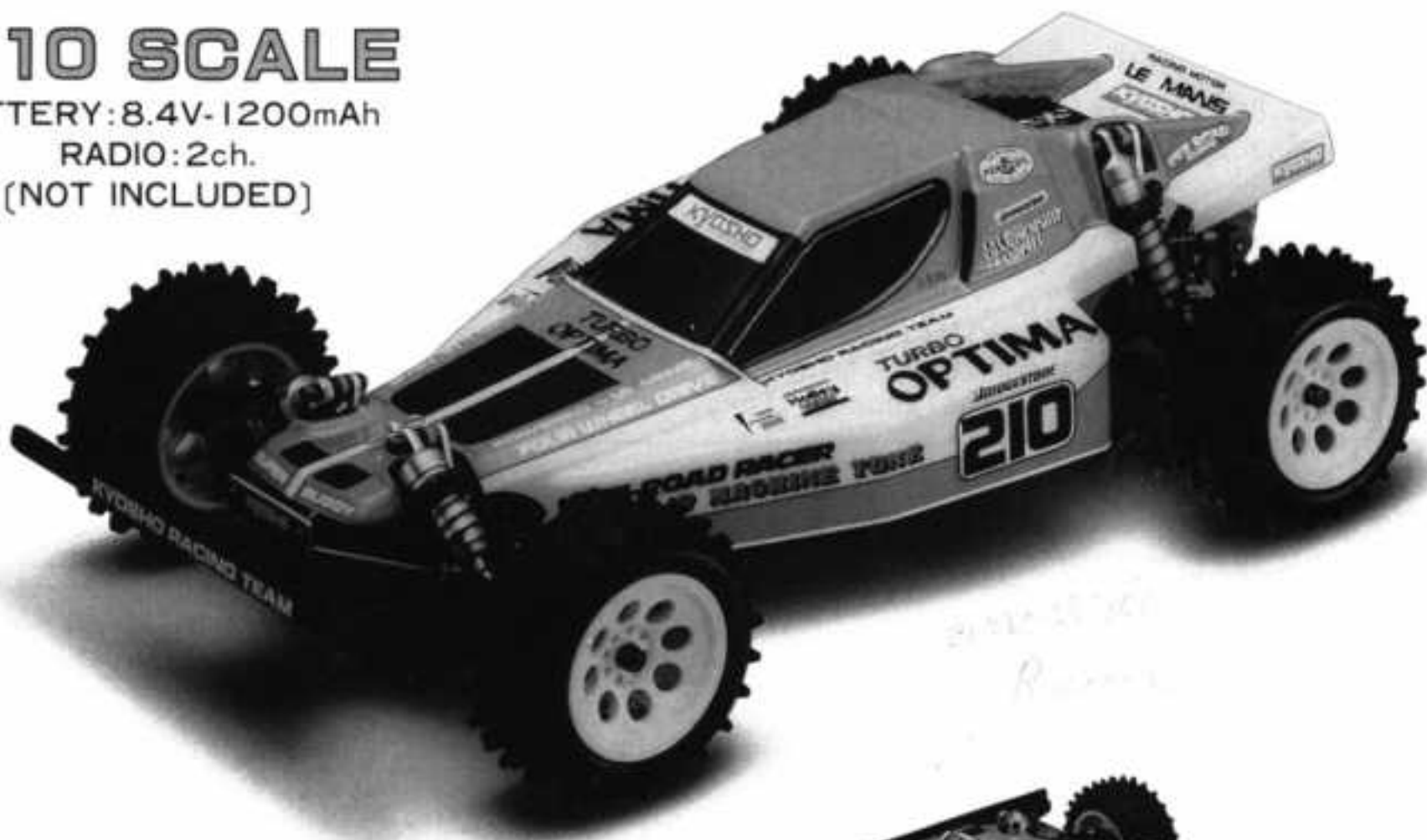

KYOSHO
THE FINEST RADIO CONTROL MODELS
KIT No.3130

4WD OFF-ROAD RACER TURBO OPTIMA

2 CHANNEL RADIO SYSTEM

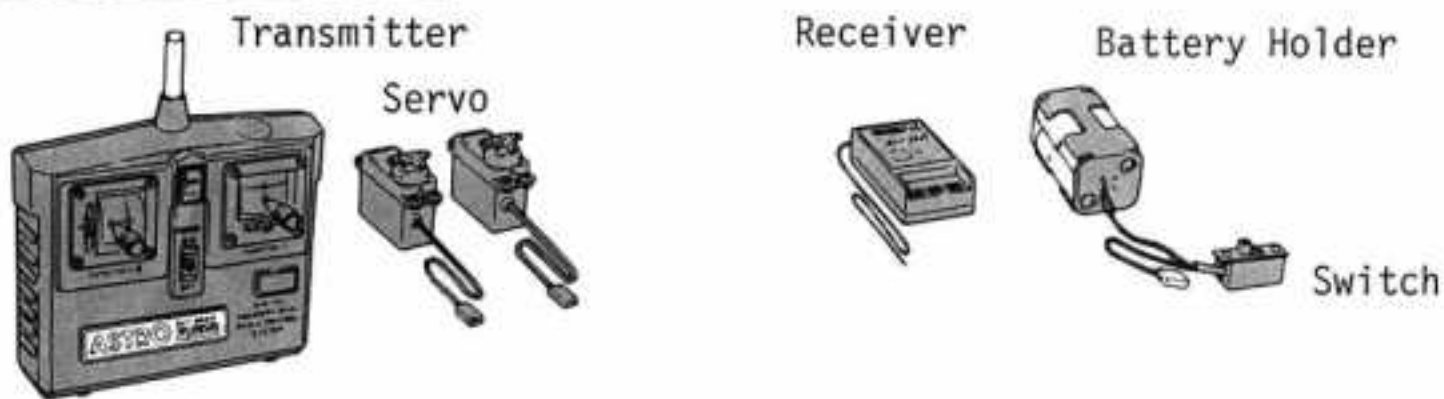

THINGS NEEDED BESIDES THE KIT

[2 Channel Radio System]

Two types of radio control sets are on the market, the stick type and the steering wheel type. Choose which ever you like.

*NOTE: The dimensions shown are the maximum sizes which will fit.

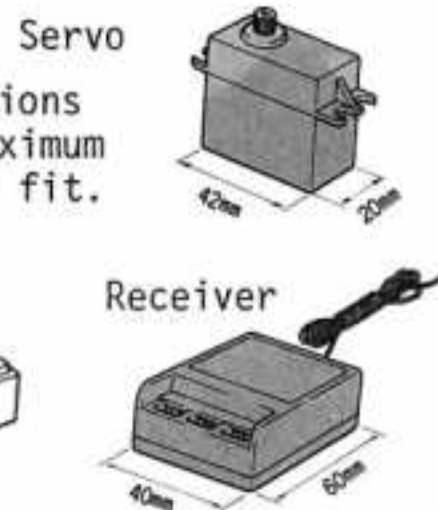

BATTERY PACK

A 8.4 V-1200 Battery in similar shape to the one shown here is required. The Kyosho #1973 is a good choice.



CHARGER

You'll need a charger to charge your battery, Kyosho offers three types:

Model	Name	Time	Features
No.1846	Multi Charger (DC 12V)	25 Min.	Full charge, wide range of batteries.
No.1848	Auto Charger (DC 12V)	35 Min.	The best fully automatic operation. Easy to use, suitable for competition.
No.1931	Super Ni-Cad AC Quick Charger	50 Min.	AC Charger from household outlet. Electronic time built-in.



No.1846



No.1848



No.1931

REQUIRED TOOLS

These are included with the "Turbo Optima"

1.5mm Allen Wrench

2mm Allen Wrench

2.5mm Allen Wrench

Silicon Grease

Screw locking compound

These are not included with the "Turbo Optima"

Phillips Screwdriver

5.5mm & 7mm Box Driver

Scissors

Needle Nose Pliers

Wire Cutters

Awl

Sharp Hobby Knife

Rubber Cement



Polyca Paint



Micron Line Tape



Brush

HOW TO CHECK YOUR RADIO SYSTEM

Follow steps 1-8.

1. Install the batteries into both the transmitter and receiver. If your radio is a rechargeable system, charge it as outlined in the manual that came with your set.
2. Unravel the receiver antenna and plug the servo and battery connectors into the receiver.
3. Extend the transmitter antenna.
4. Turn On the power switch of the transmitter.
5. Turn On the power switch of the receiver.
6. Set the small trim levers to the center position and make sure that both main control sticks are also centered.
7. Move both main control sticks slowly through their full travel. The servo horns should move in proportion to the movement of your sticks.
8. When trim levers and sticks are at their neutral positions, the servo horns should be centered. You may now turn off the transmitter, then the receiver and unplug the servos and battery from the receiver.

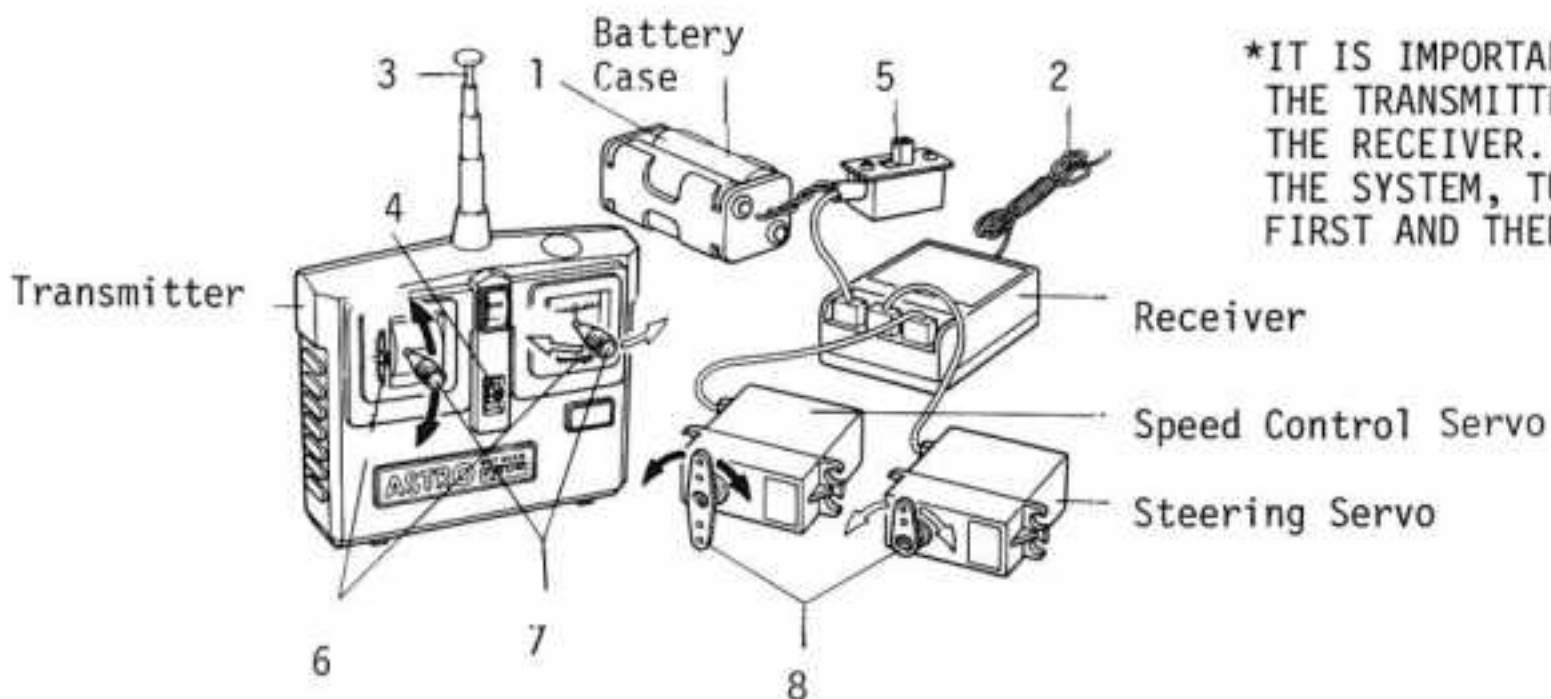

***IT IS IMPORTANT TO ALWAYS SWITCH THE TRANSMITTER ON FIRST... THEN THE RECEIVER. WHEN TURNING OFF THE SYSTEM, TURN OFF THE RECEIVER FIRST AND THEN THE TRANSMITTER.**



A 2-channel radio control system is composed of a transmitter, receiver, two servos, and a battery holder (for the receiver).

- *Transmitter This is the part of the system that you hold in your hands to control the model. Information is sent to the receiver and servos via radio waves.
- *Receiver Receives the radio signals from the transmitter and sends them to the appropriate servo.
- *Servos It can be thought of as the "muscle" of the system. They actually move the controls of the model. The receiver tells them which direction to move and how much.
- *Antenna The transmitter antenna broadcasts the radio signal. The receiver antenna (which is no more than a small wire tuned to a precise length) picks up the signals so that the receiver can decode them.
- *Trim Levers Adjust the neutral position of the servos from the transmitter. Trim levers provide fine tuning of the steering and speed control.
- *Battery Meter ... Allows you to see the condition of your transmitter batteries.
- *Servo Horn A small arm or wheel on a servo that transfers the movement of the servo.

BEFORE ASSEMBLY

Please read through these instructions before assembly. Your thorough understanding of the assembly will enable you to build the kit without difficulty. Check the components in the kit prior to your starting the assembly. Any claims for replacements or refunds for the model in the process of assembly will not be accepted.

[Please understand the following points before assembly]

1. Places where grease and "locktite" should be applied;
Apply some grease, which is included in the kit, to the spots indicated with mark , and "locktite" with .
2. Small Parts
The small parts to be used such as screws, nuts, washers are illustrated in the actual size on the attached sheet "The List of Small Parts". Pick up the correct ones referring the size, shape, and the assembly number.
3. Some Hints when screwing in a self-tapping-screw, (hereinafter referred to as TP Screw).
*This model uses a lot of plastic parts, and many TP screws will be used for assembling.
*Do not use excessive force when tightening the self-tapping screws, or you may strip the thread in the plastic. It is recommended to stop tightening it when the threaded part on the screw goes into the plastic part and you feel some resistance from the tightening.
4. Shape of Screw
*You can distinguish the ordinary screw from the self-tapping one by the shape of points and thread.

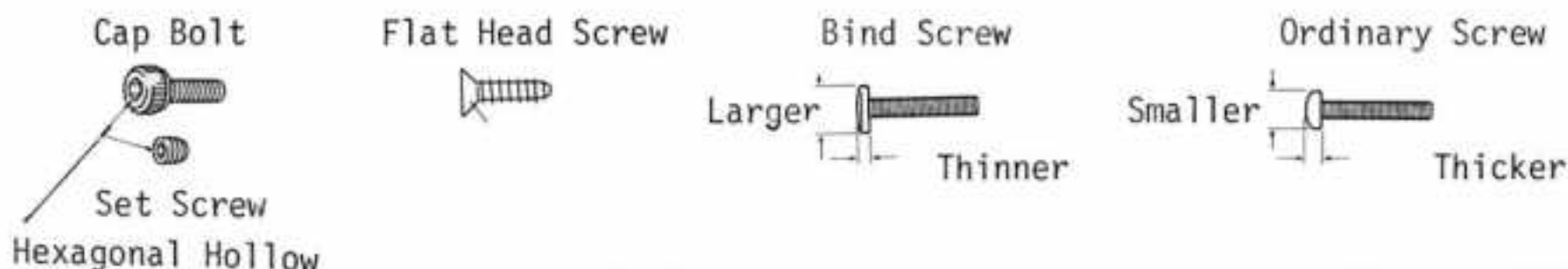
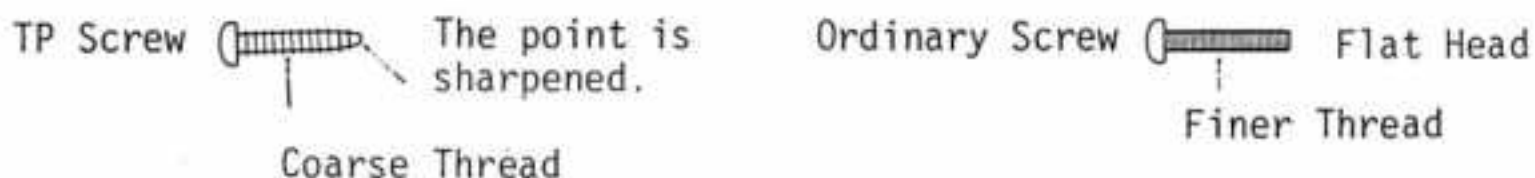

1 INSTALLATION OF JOINT

Assembly drawing of Front and Rear Diff.
refer to Page 24.

M4 x 4 Set Screw

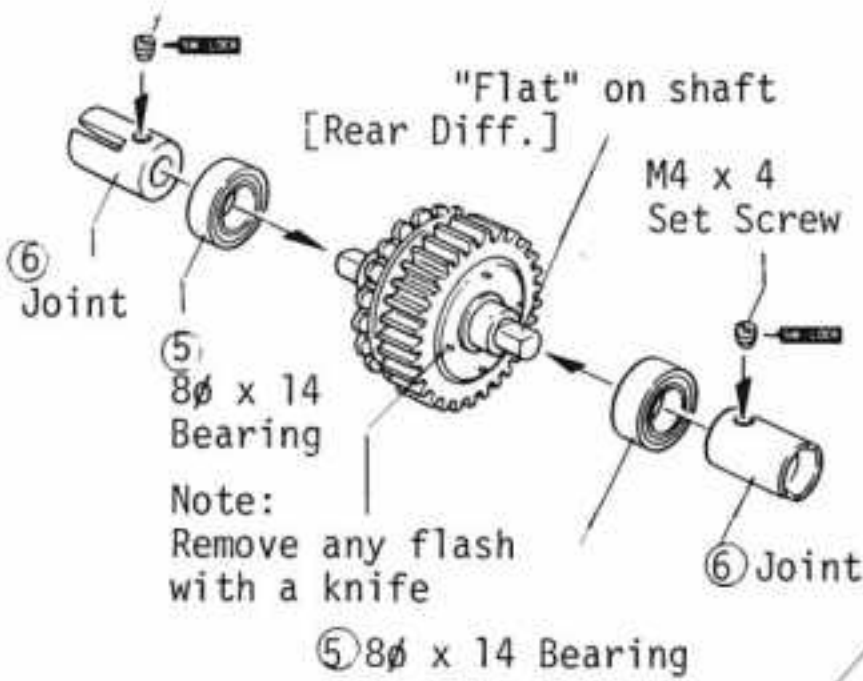

M4 x 4 Set Screw

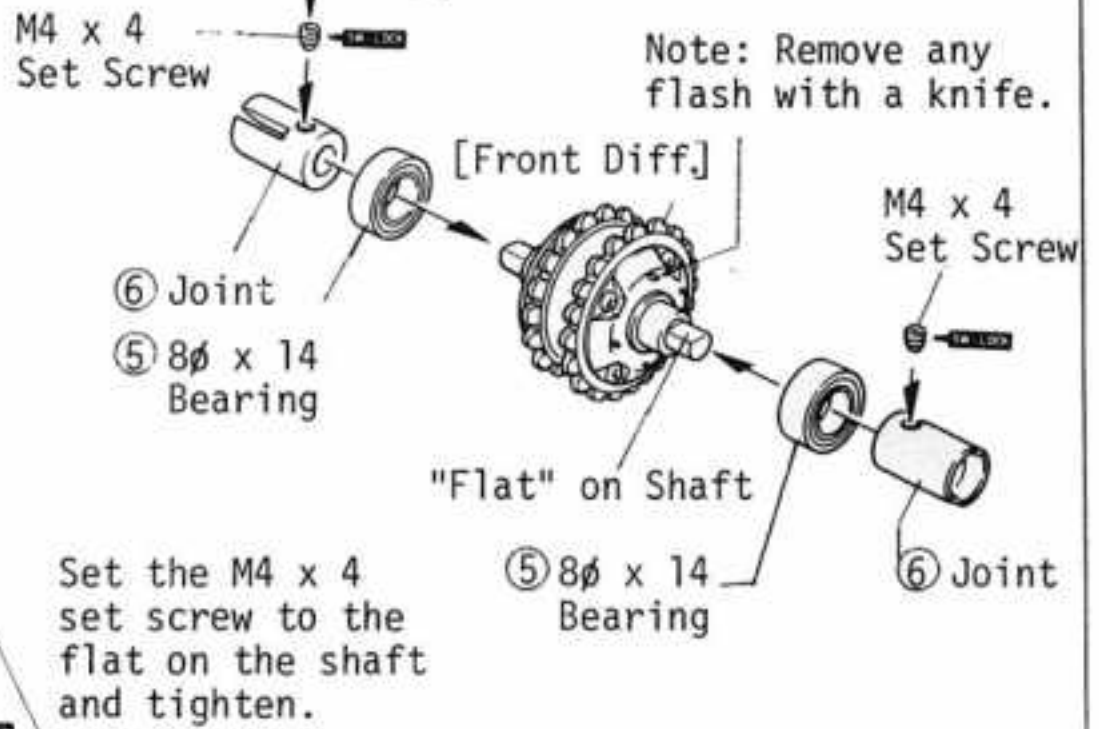

2 ASSEMBLY OF REAR GEAR BOX

⑩ Final Pinion Gear

⑨ Gear Box (L)

M3 x 18 TP Screw

M4 x 4 Set Screw

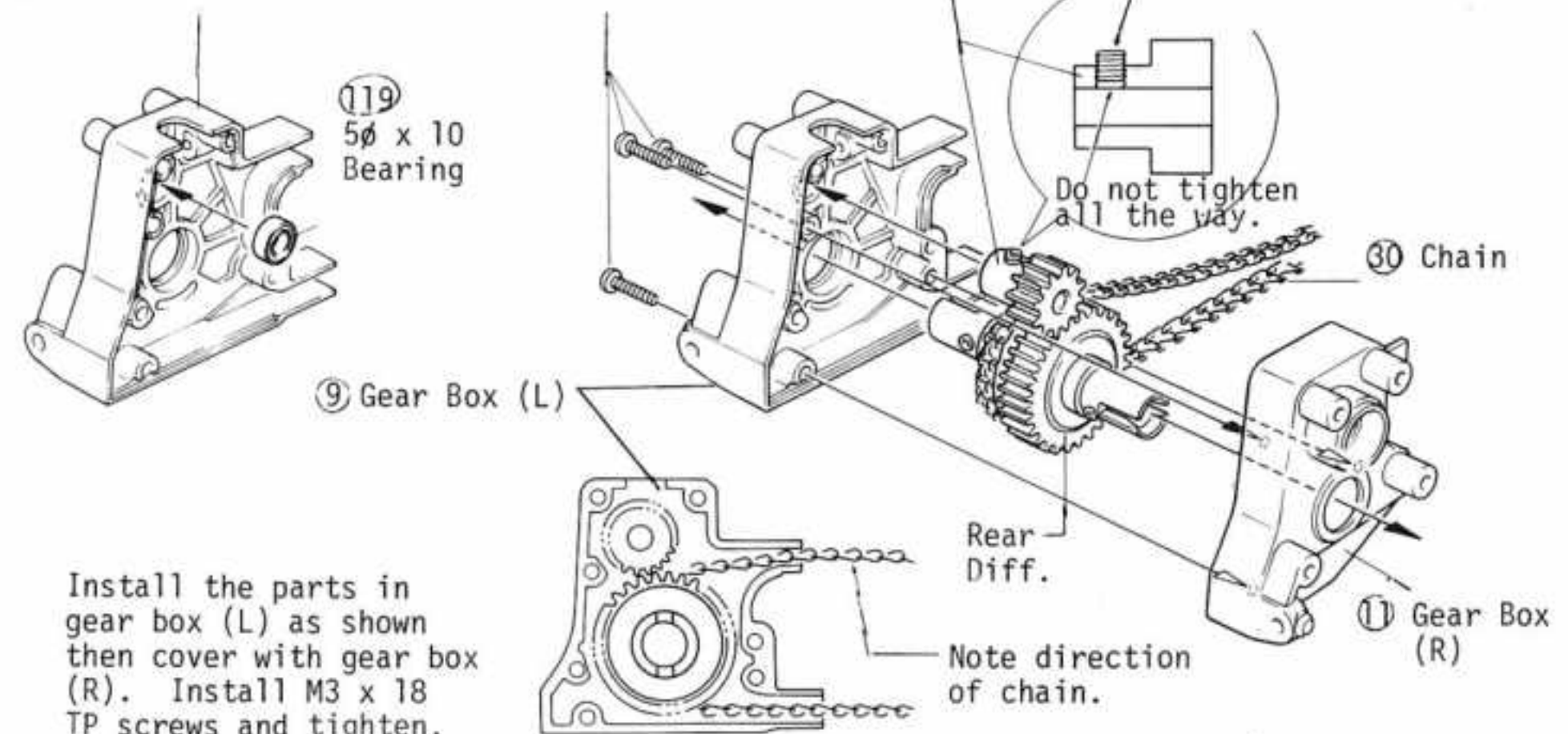

Never apply grease or oil to rear diff. and Final Pinion Gear.

3 INSTALLATION OF GEAR BASE

M3 x 45 Bind Screw

M3 Spring Washer

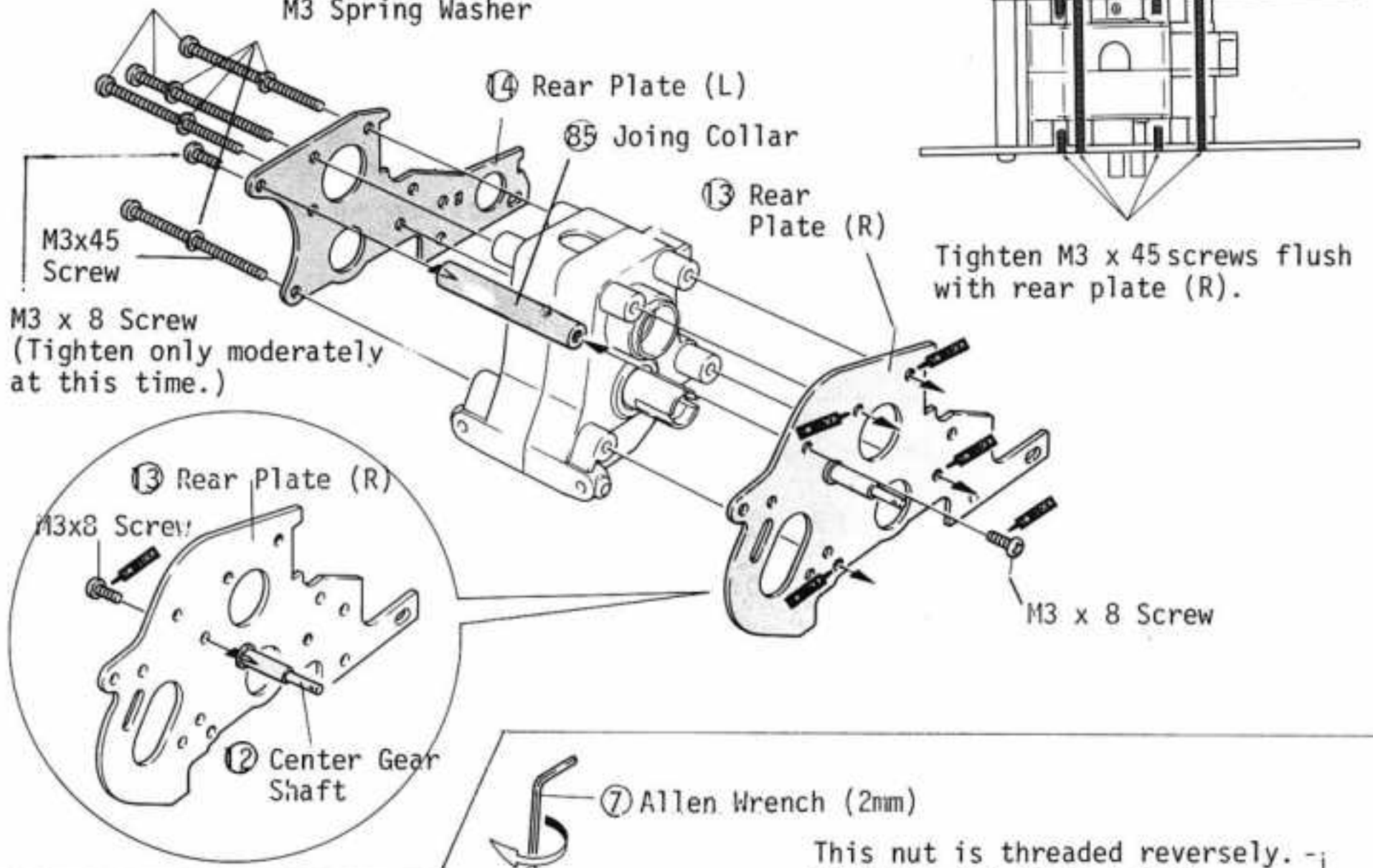

4 INSTALLATION OF FINAL PINION GEAR

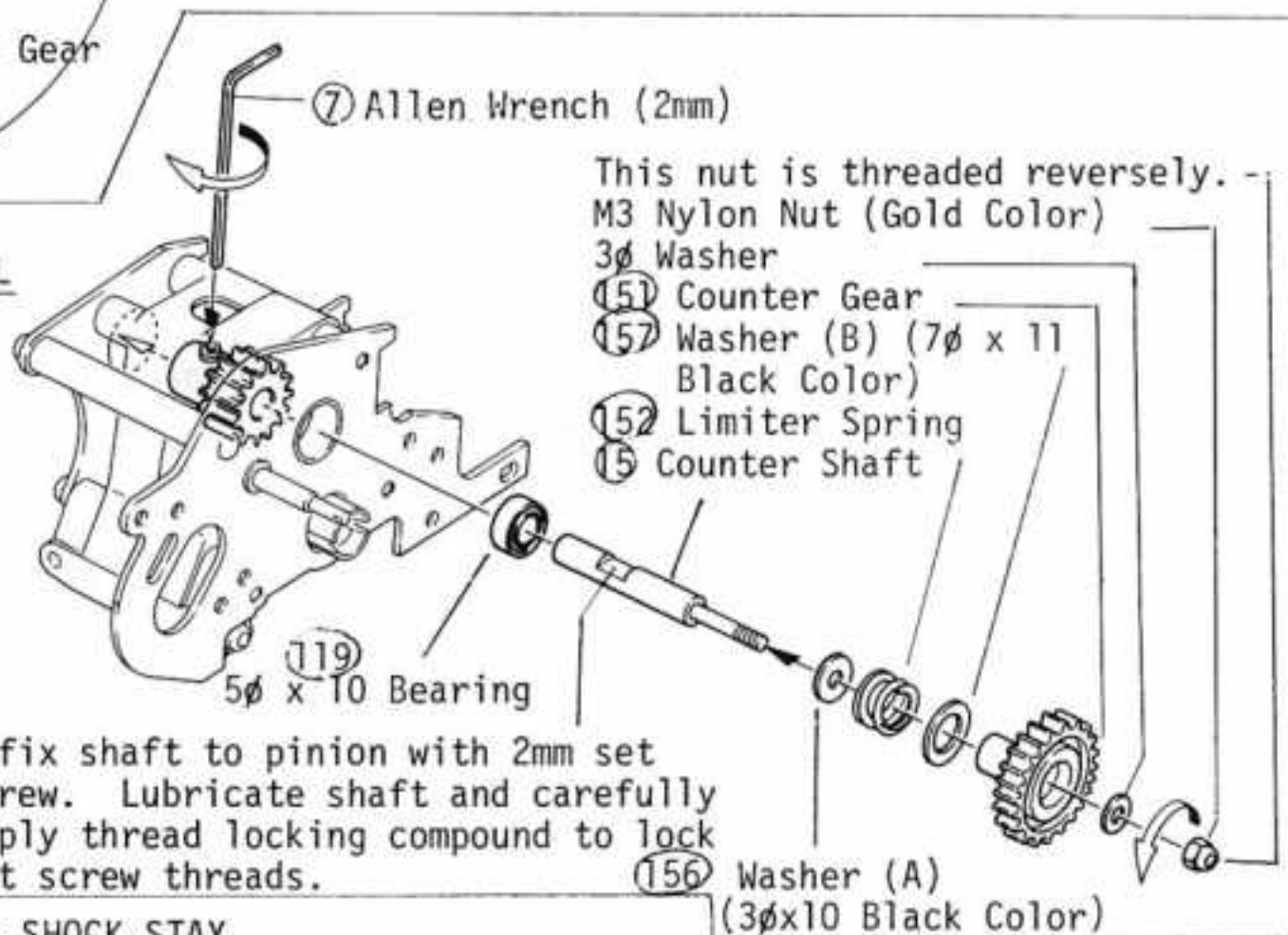

5 INSTALLATION OF REAR SHOCK STAY

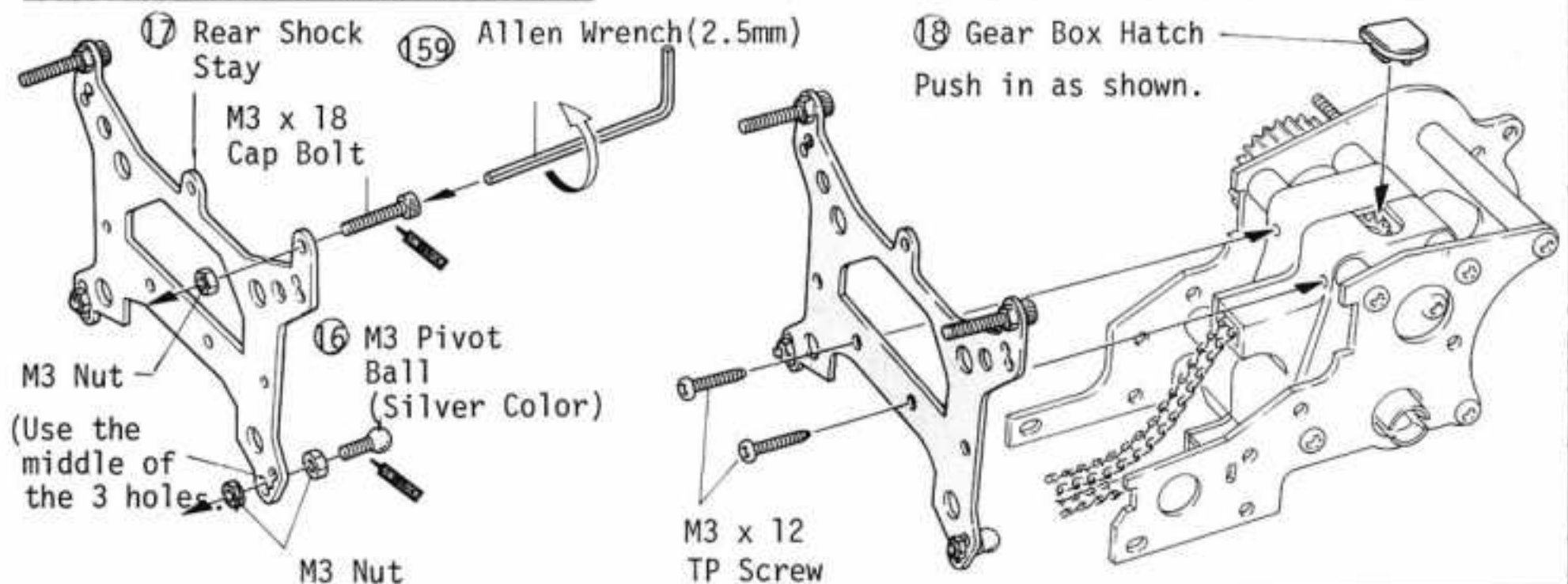

6 INSTALLATION OF FRONT GEAR BOX

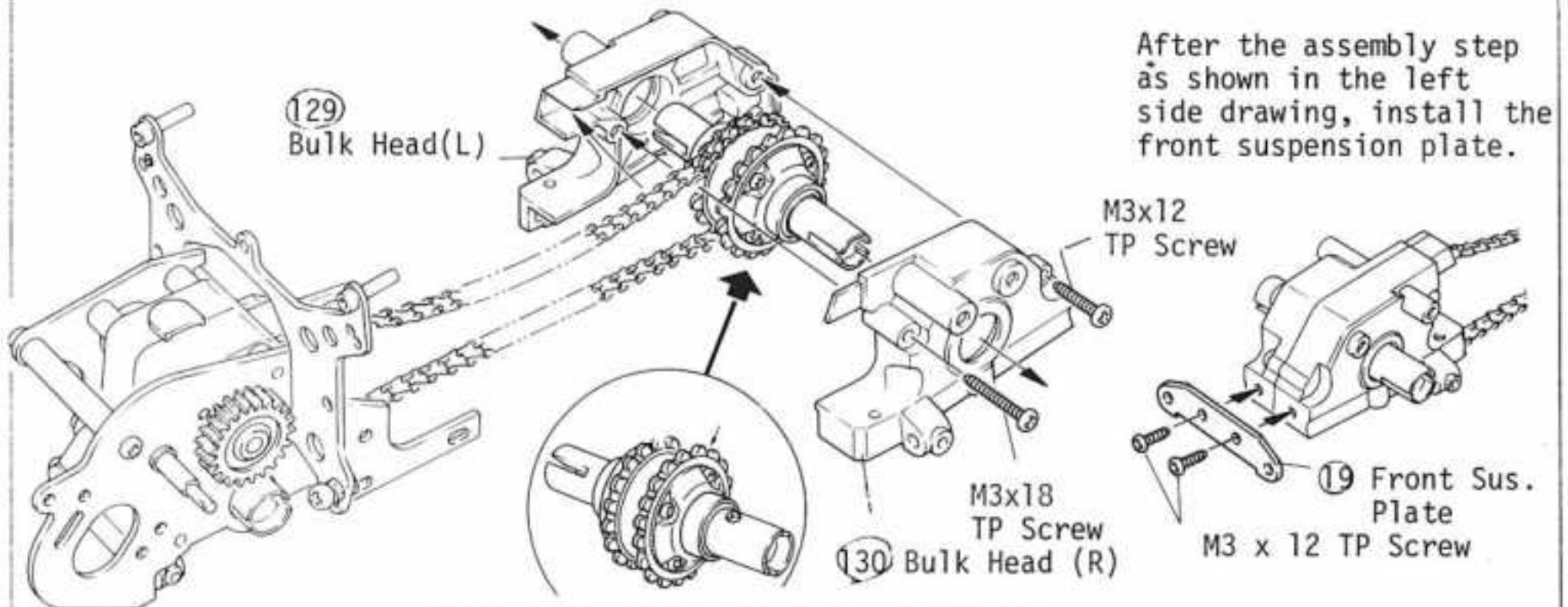

After the assembly step as shown in the left side drawing, install the front suspension plate.

Note: Never apply grease or oil to the sprocket.

*Two types of sprockets are available (18 and 19 teeth). For the standard process, use the 18 teethed one to engage the chain on.

7 INSTALLATION OF LOWER GUARD

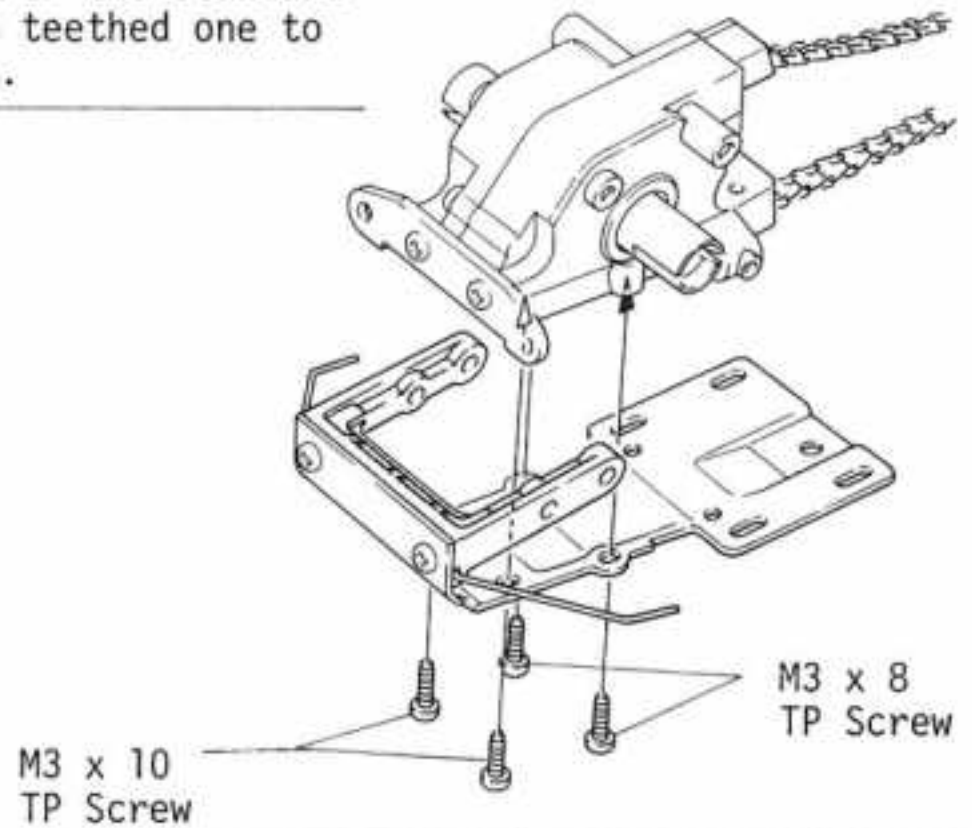
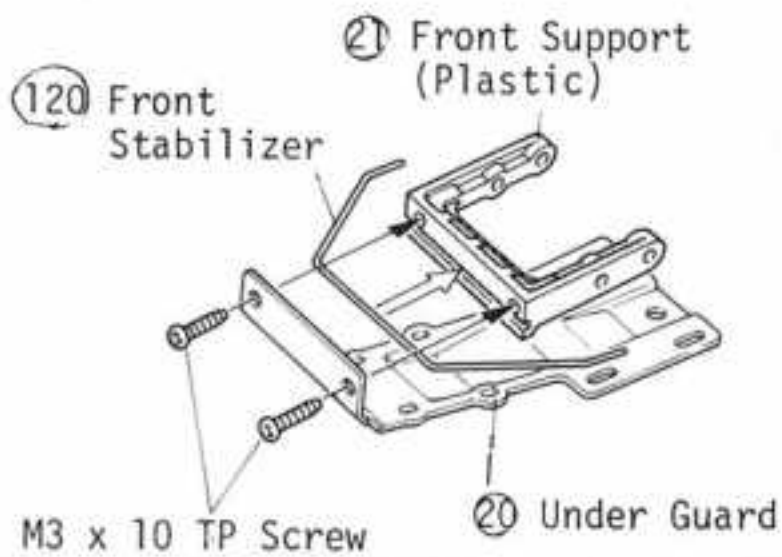

8 INSTALLATION OF REAR PLATE

NOTE:
These holes are out of the center line.
Assemble the chassis in such a way that the holes will be located inside.

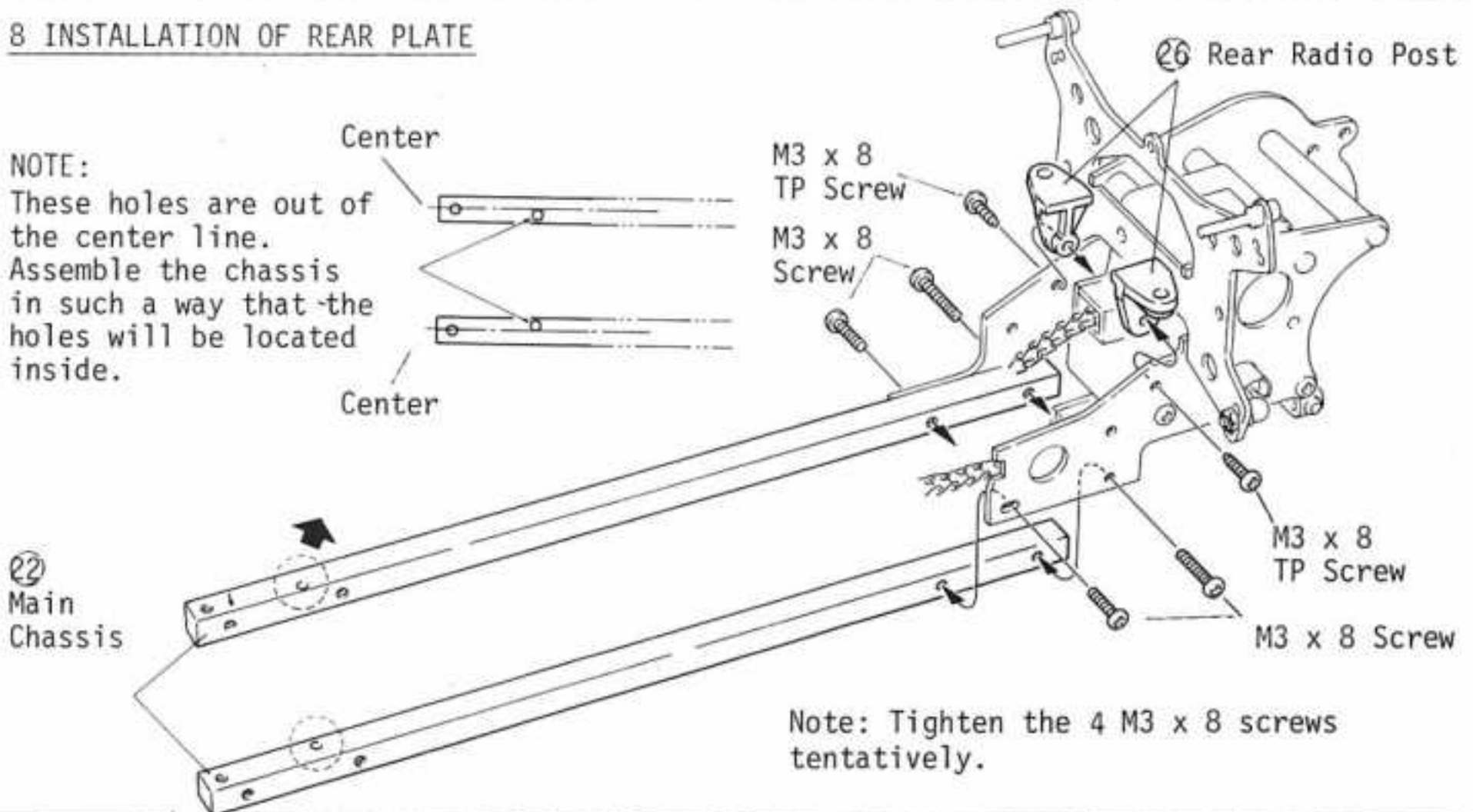

9 INSTALLATION OF BULK HEAD

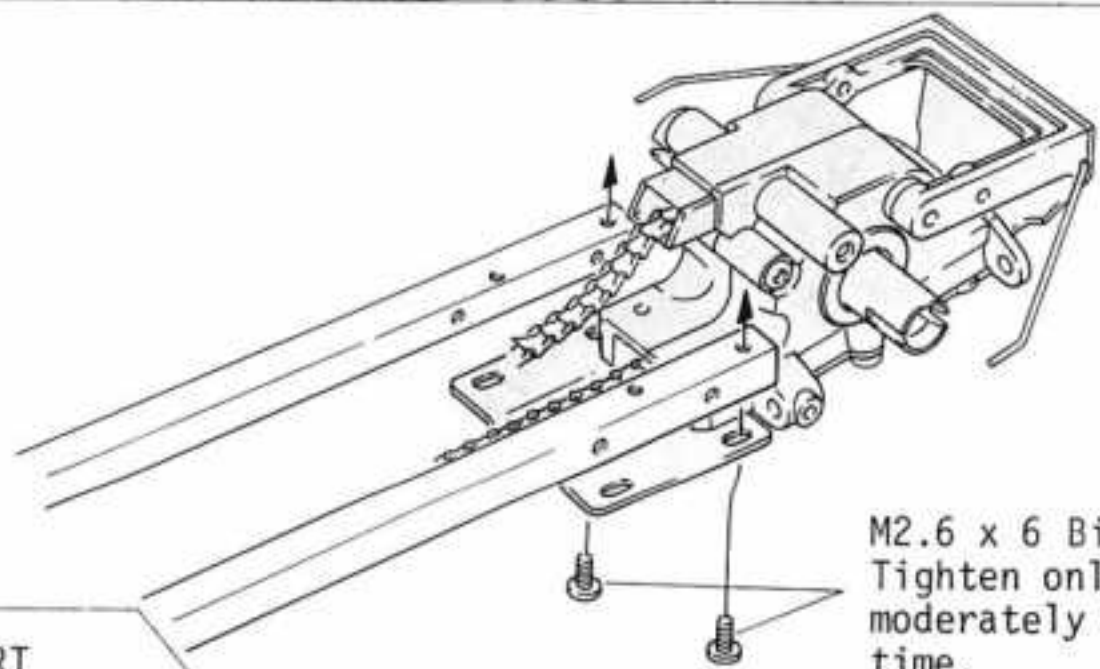

M2.6 x 6 Bind Screw
Tighten only moderately at this time.

10 INSTALLATION OF FRONT SUPPORT

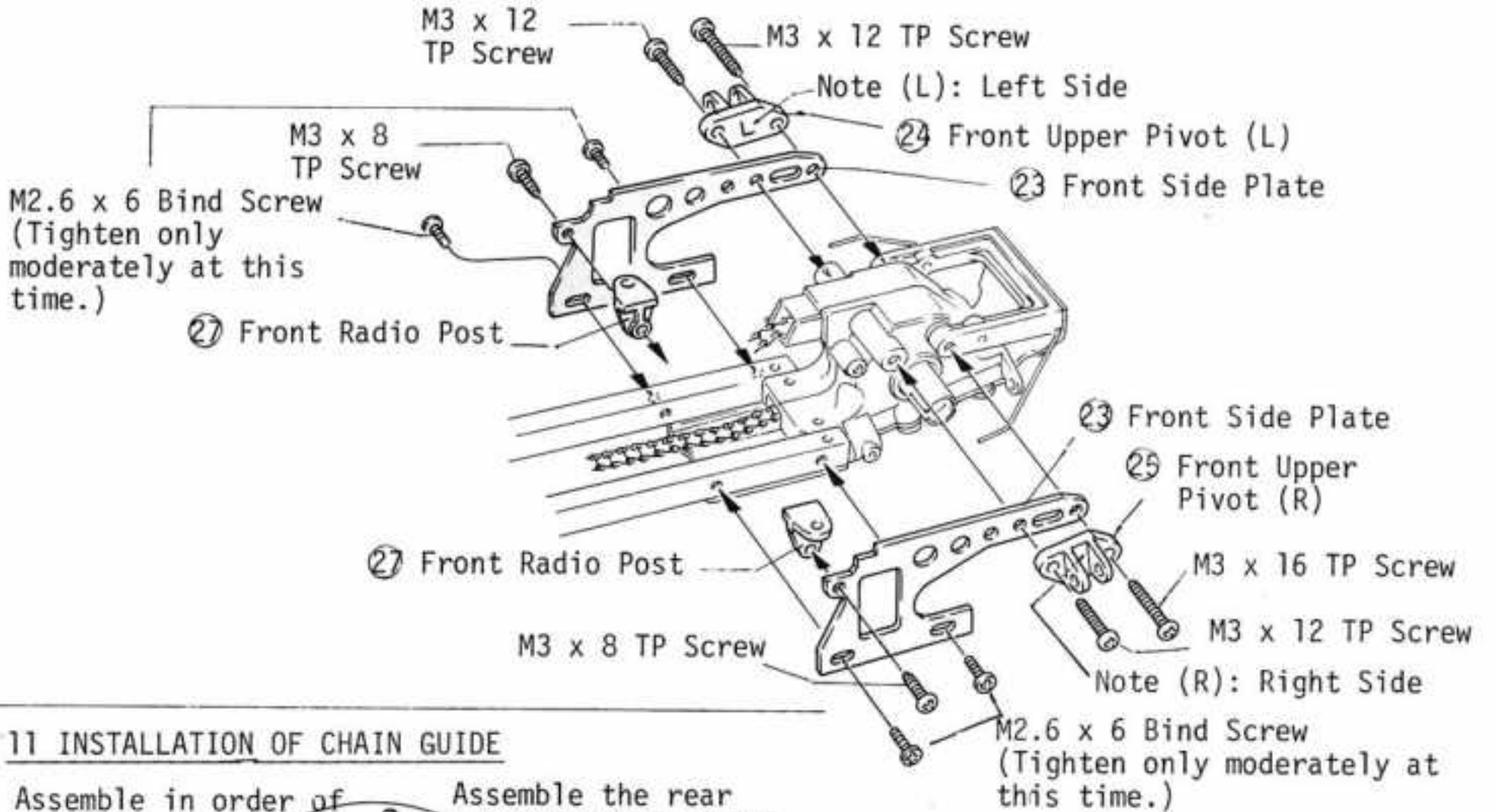

11 INSTALLATION OF CHAIN GUIDE

Assemble in order of white No. in black circle.

Assemble the rear portion of the chain guide as shown.

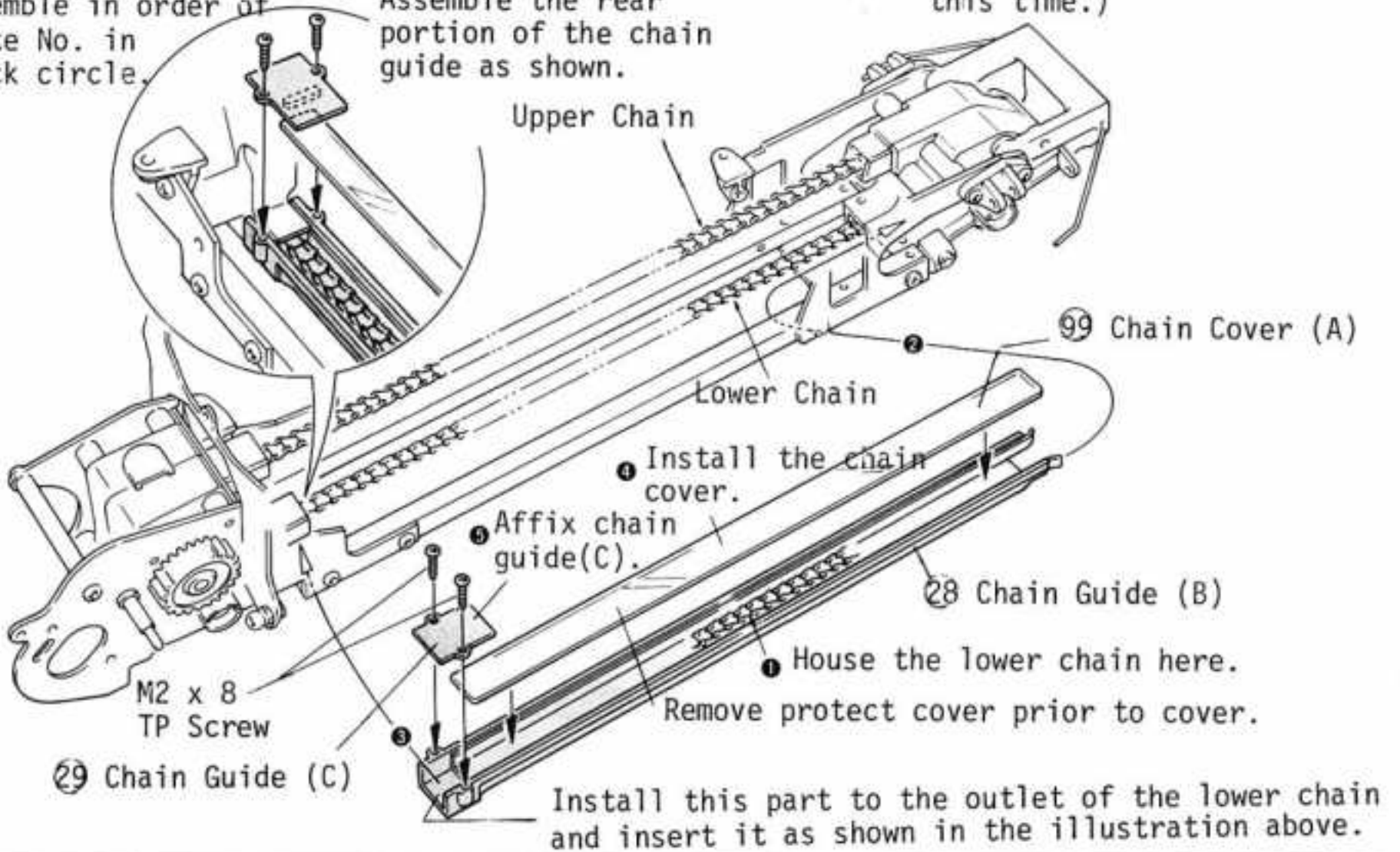

Install this part to the outlet of the lower chain and insert it as shown in the illustration above.

12 INSTALLATION OF JOING COLLAR

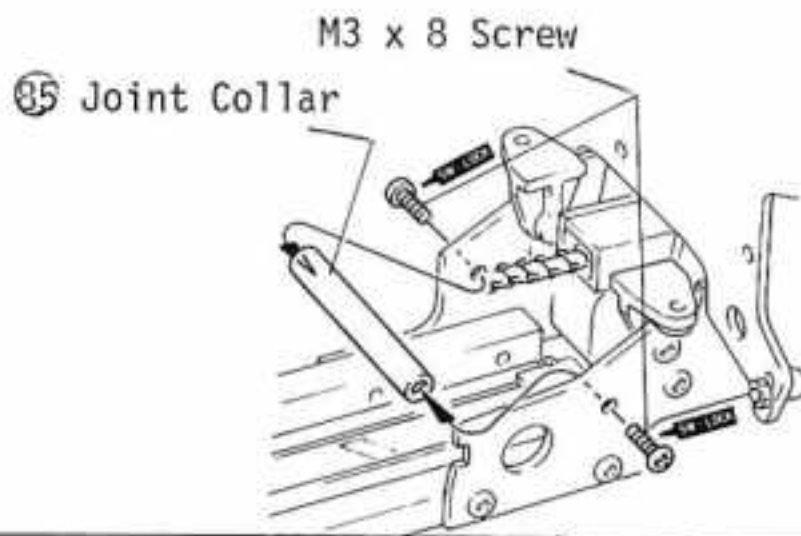

If you have any difficulty to fix the joint collar 35, loosen the four M3 x 45 screws on the gearbox, then you can install it much easier.

13 ASSEMBLY OF SERVO SAVER

[Assembly of Servo Saver (A)]

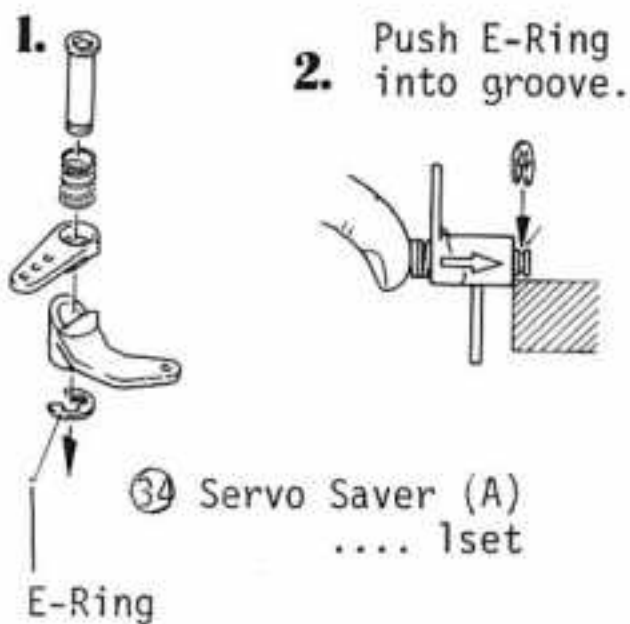

3. Attach them with pliers.

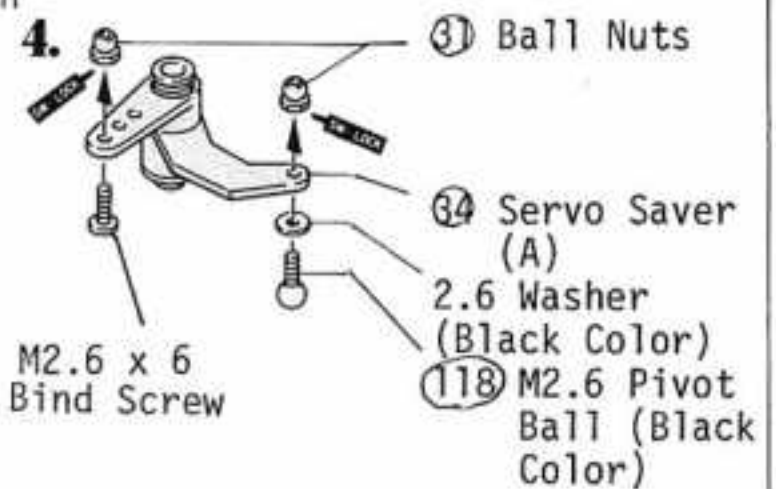
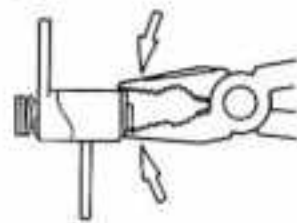

[Assembly of Servo Saver (B)]

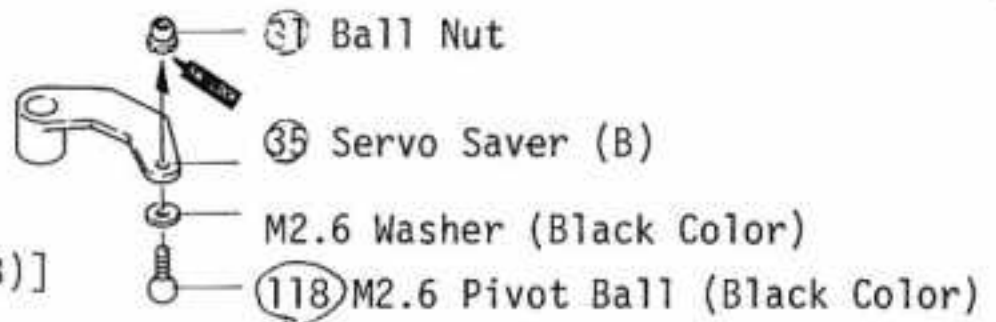

14 INSTALLATION OF SERVO SAVER

[Screw in the Ball End]

Remove this portion with knife.



37 Ball End (S)

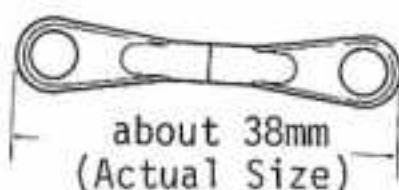
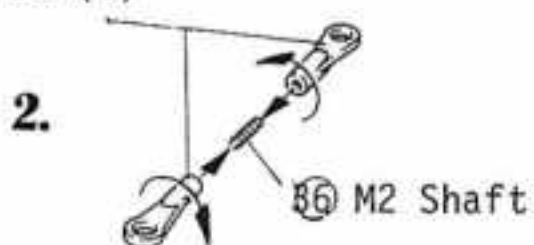

32 Saver Shaft (A)

33 Saver Shaft (B)

105 Saver Spacer

M2.6 x 15 Bind Screw

This is the ball end prepared in the step as shown in the left side illustration.

34 Servo Saver(A)

35 Servo Saver(B)

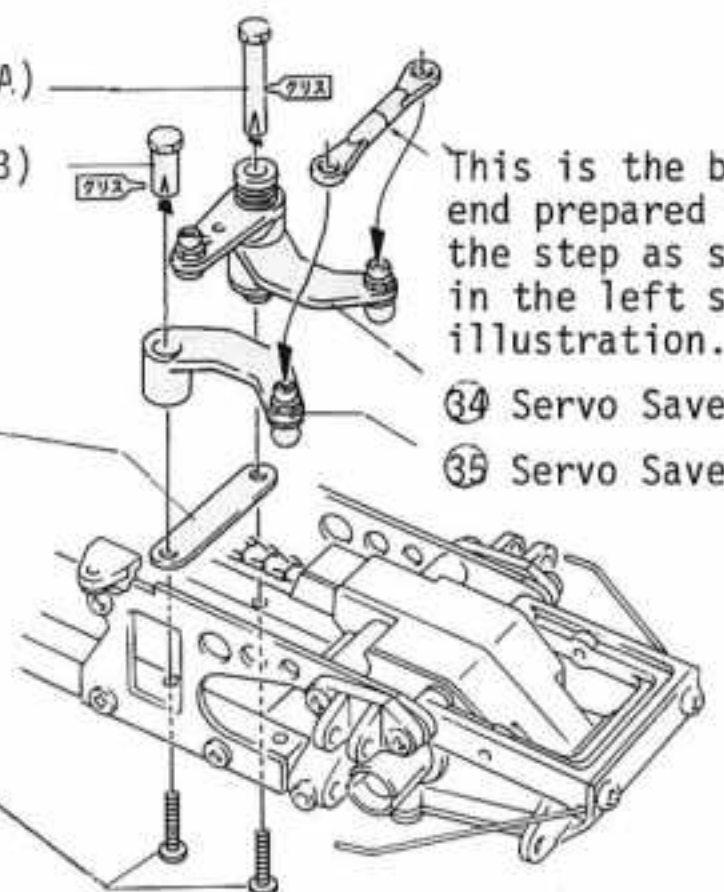

15 ASSEMBLY OF KNUCKLE ARM

119 5ø x 10
Bearing

41 Front
Shaft

1.

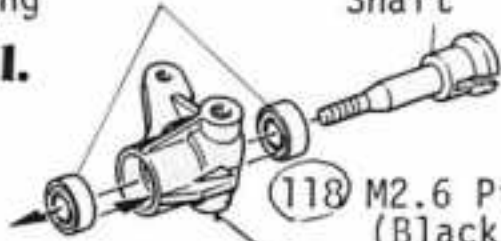

2.

118 M2.6 Pivot Ball
(Black Color)

39 Knuckle Arm 1 (L)

M2.6 Nut

38 King Pin

38 King Pin

*Before installing the knuckle arm onto chassis, be certain to confirm which is 1 (L) and 2 (R).

M3 Pivot Ball
(Silver Color)

42 Front Hub (L)
(Plastic)

Leave a gap of 1mm.

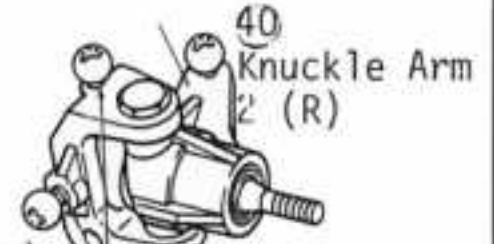

43 Front Hub (R) (Plastic)

16 INSTALLATION OF FRONT SUSPENSION ARM

8 Stabilizer End
Ball (Gold Color)

M3x4
Set Screw
(Silver Color)

45 Suspension Shaft(A)
(Silver Color)



Attach the E-ring with
needle nose pliers.

44 E-ring

"Flat" on
surface.



46 Suspension
Shaft (B)
(Silver Color)

17 INSTALLATION OF FRONT UPPER ROD

[Make two Upper Rods]

60 Ball End (L)

49 5.8ø Ball

61 Upper Rod



Push Ball end
onto pivot ball.

This is the front shock
prepared in the step as
shown in the left side
illustration.

[Attach M3x18 cap bolts to the
front shock stay]

M3 x 18
Cap Bolt

52 Front
Shock
Stay

This is the upper rod prepared
in the step as shown
in the left side
illustration.

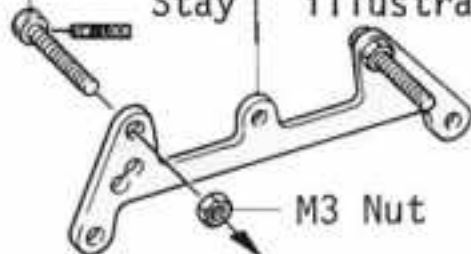

M3 Nut

M3 Nylon Nut

M3 Nylon Nut

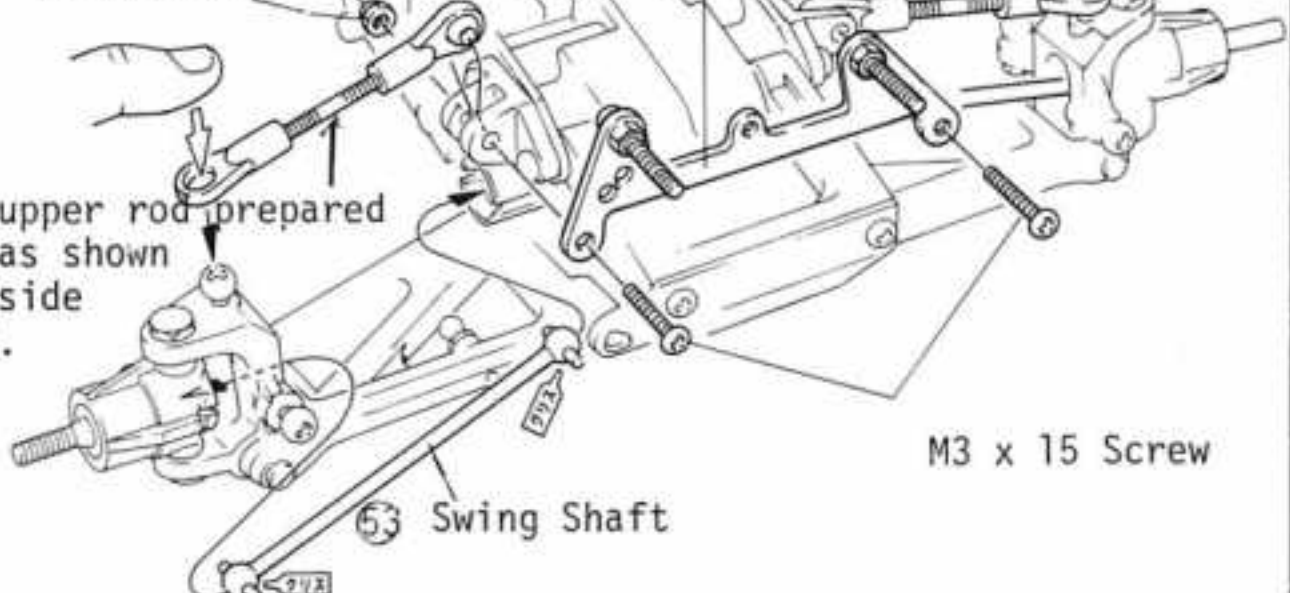

M3 x 15 Screw

53 Swing Shaft

18 ASSEMBLY OF SHOCK

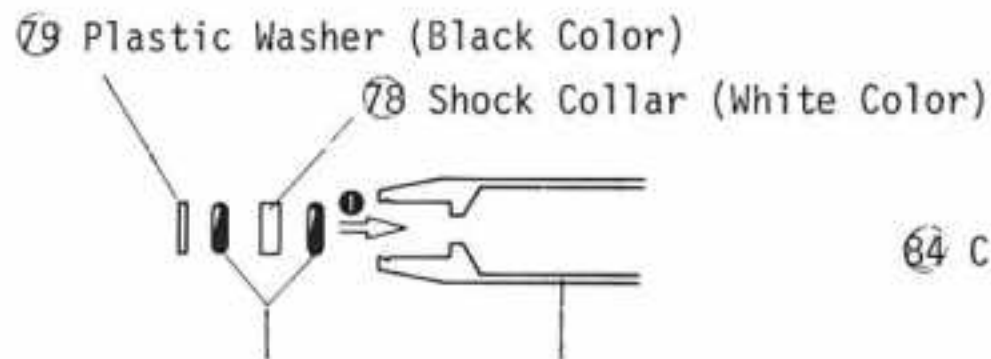
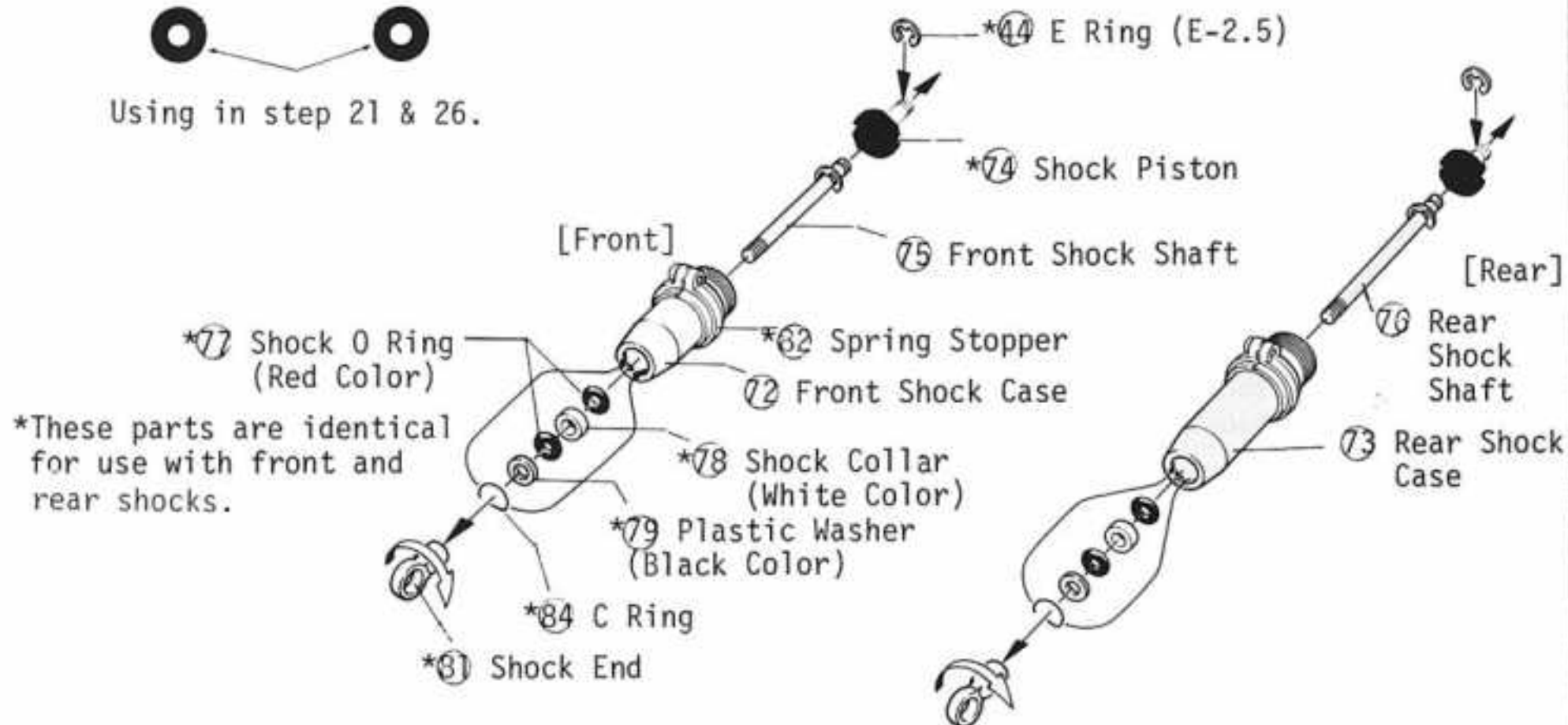
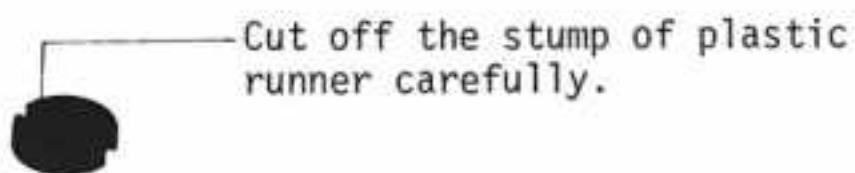
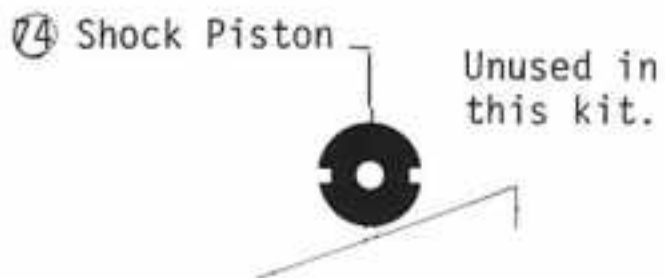

77 Shock O Ring 72, 73 Shock Case

Secure the piston with an E-ring.

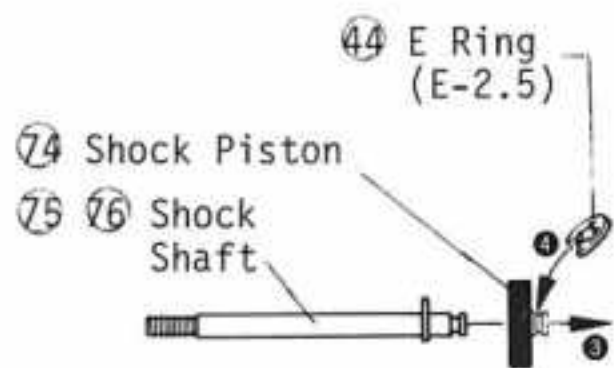

Fit a C-ring here. (Be careful not to loose it.)

Fit it into this groove.



Let the shaft go through the shock case, and screw in the shock end.

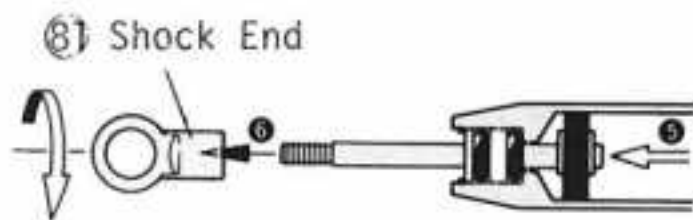

Screw it in.

19 FILLING SHOCK WITH OIL

[Installation of Diaphragm]

Fit the diaphragm (83) into the shock cap (155).

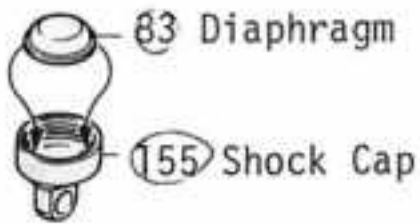

Fit it into the groove rigidly.

1. ⑦ Shock Oil

Put the oil a little excessively.

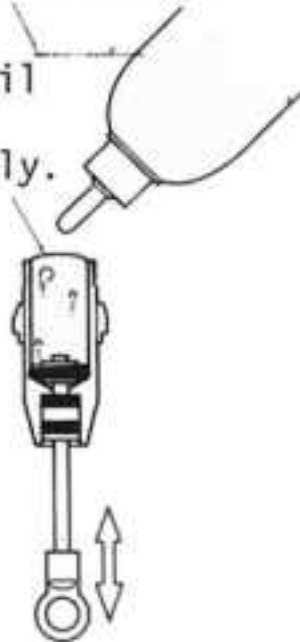

2.

(155) Shock Cap

Tighten the cap firmly so that no oil will run out.

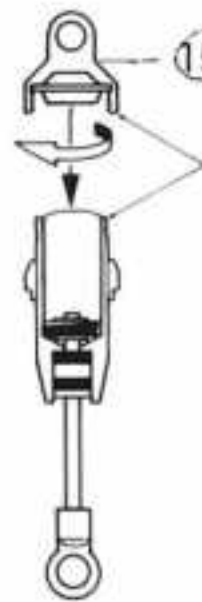

3.

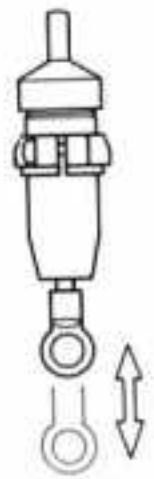

Movable smoothly

1. Push the piston all the way down and pour the oil little by little. Move the piston up and down slowly to get rid of air bubbles.
2. Keep the piston at the bottom and screw in the shock cap (155) gently, then any excessive oil will flow out.
3. Check to see if the piston will move smoothly by reciprocating it.

20 INSTALLATION OF SHOCK SPRING

The shorter spring is for front and the longer for rear.

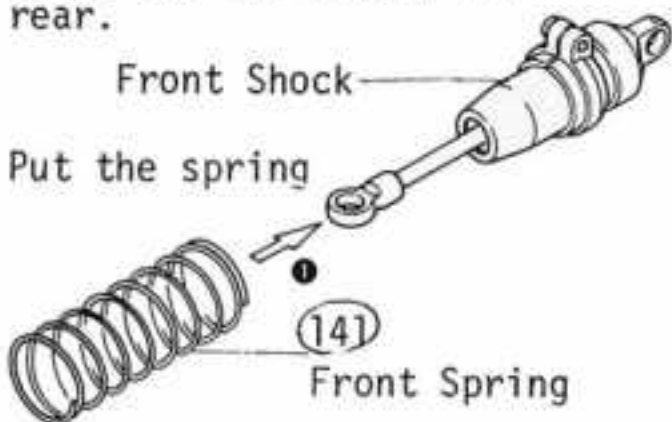

The last step in assembling the shocks is to fit the spring holder (80) by compressing the spring.

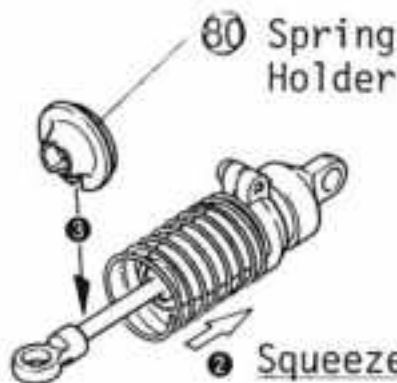

Squeeze it.

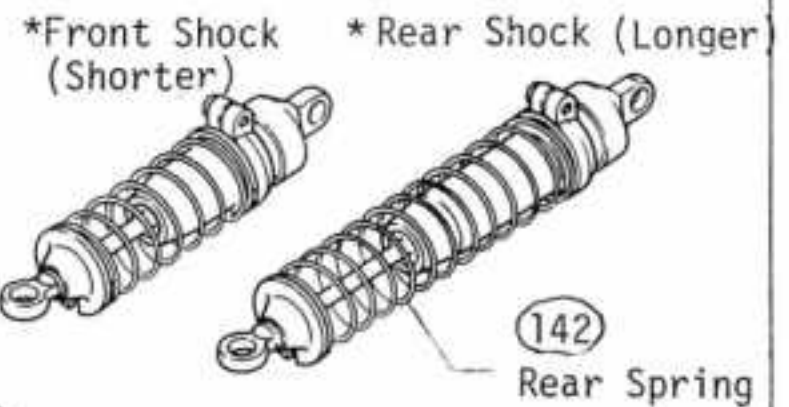

21 INSTALLATION OF FRONT SHOCK

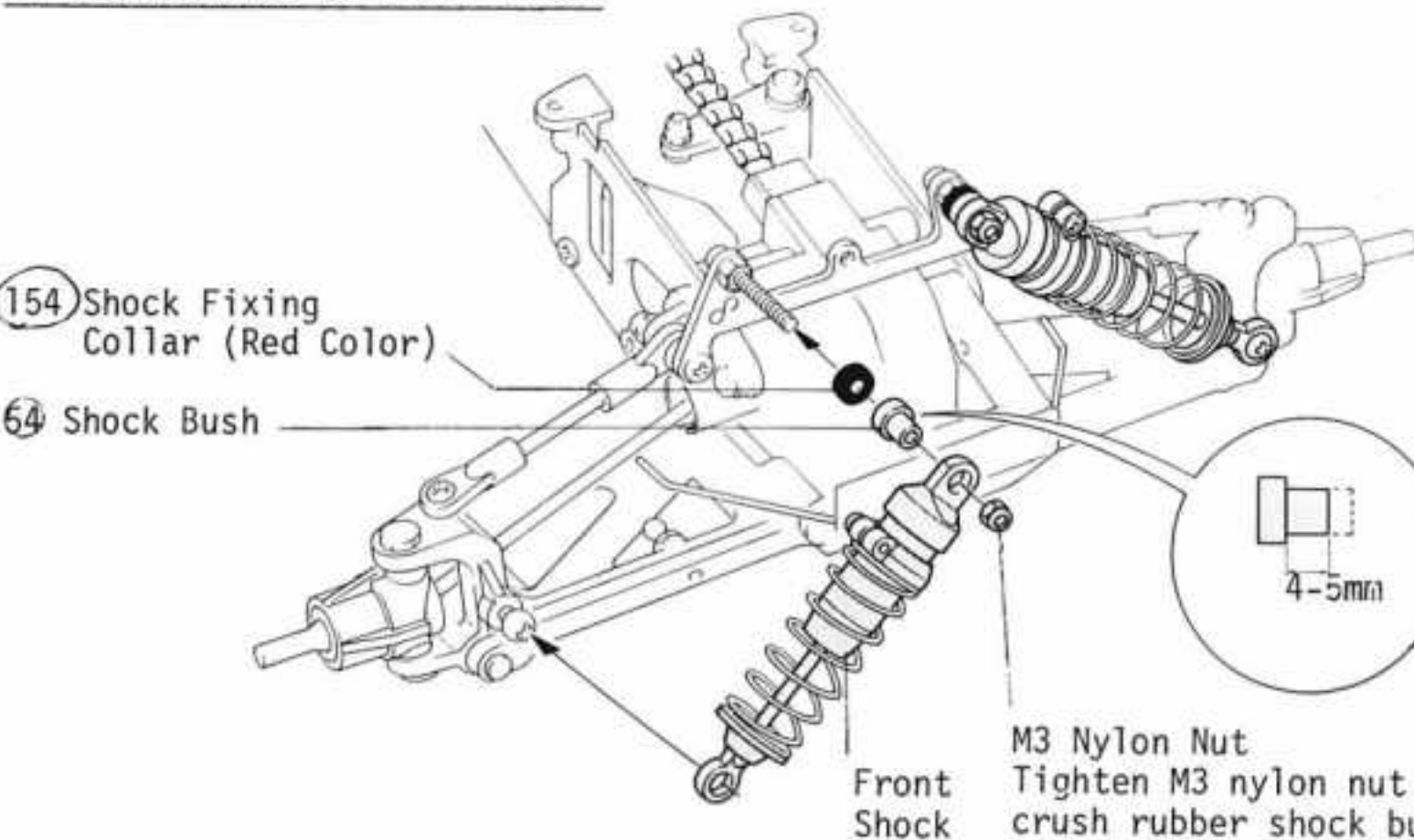

(154) Shock Fixing Collar (Red Color)

(64) Shock Bush

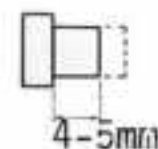

Trim bushing as shown.

M3 Nylon Nut
Tighten M3 nylon nut firmly but do not crush rubber shock bushing.

22 INSTALLATION OF TIE ROD

[Make two Tie Rod]
 60 Ball End (Large)

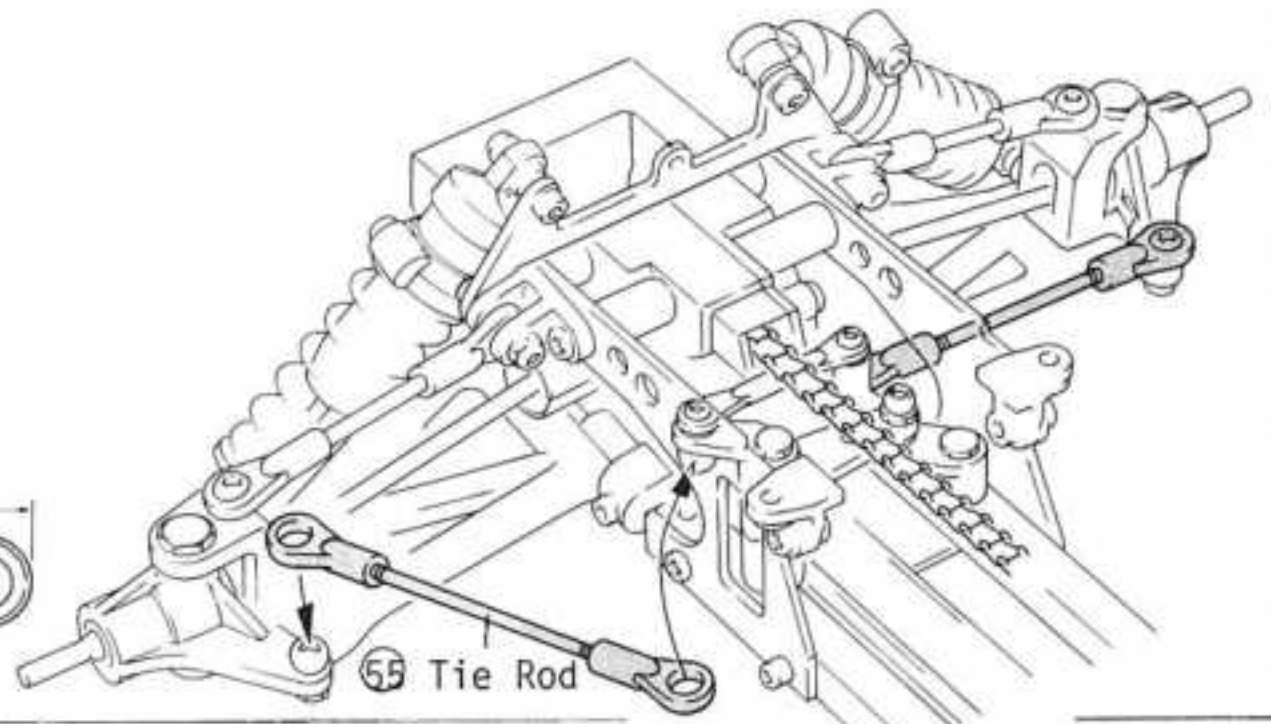
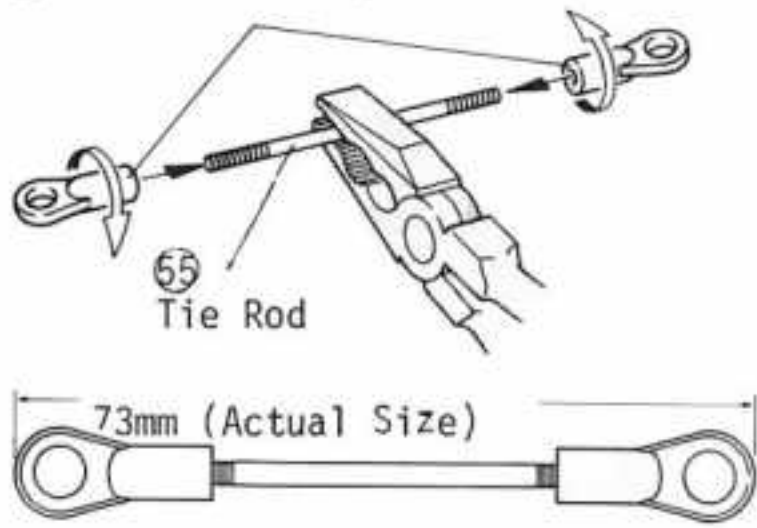

23 INSTALLATION OF REAR HUB

119 50x10 Bearing
 56 Rear Shaft

Right

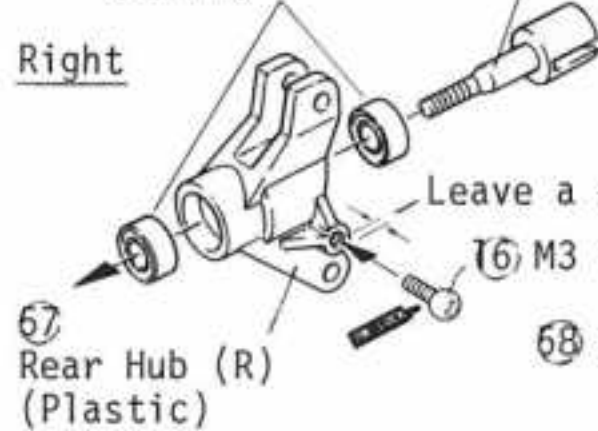

*Assemble the left side rear hub (L) 139 in the same way.

57 Rear Hub (R)

16 M3 Pivot Ball (Silver Color)

58 Suspension Shaft (C) (Black Color)

Right



8 Stabilizer End Ball (Gold Color)

Left

139 Rear Hub (L)

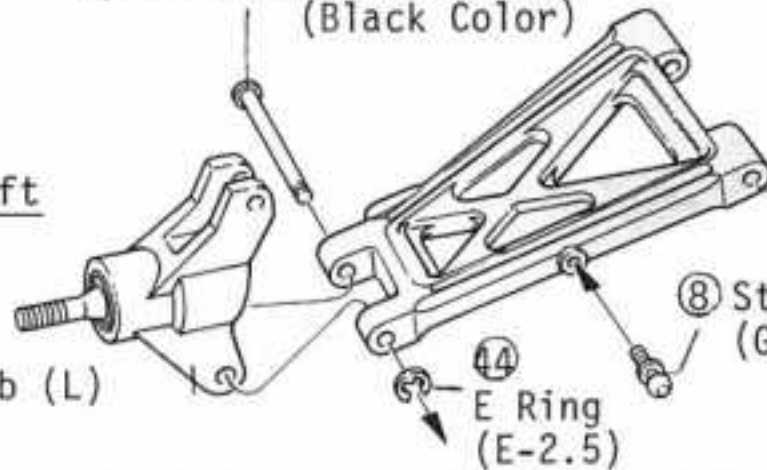

14 E Ring (E-2.5)

8 Stabilizer End Ball (Gold Color)

59 Rear Suspension Arm

24 INSTALLATION OF REAR SUSPENSION ARM

22 Main Chassis

Make sure 60 Suspension shaft seats firmly into hole on the main chassis.

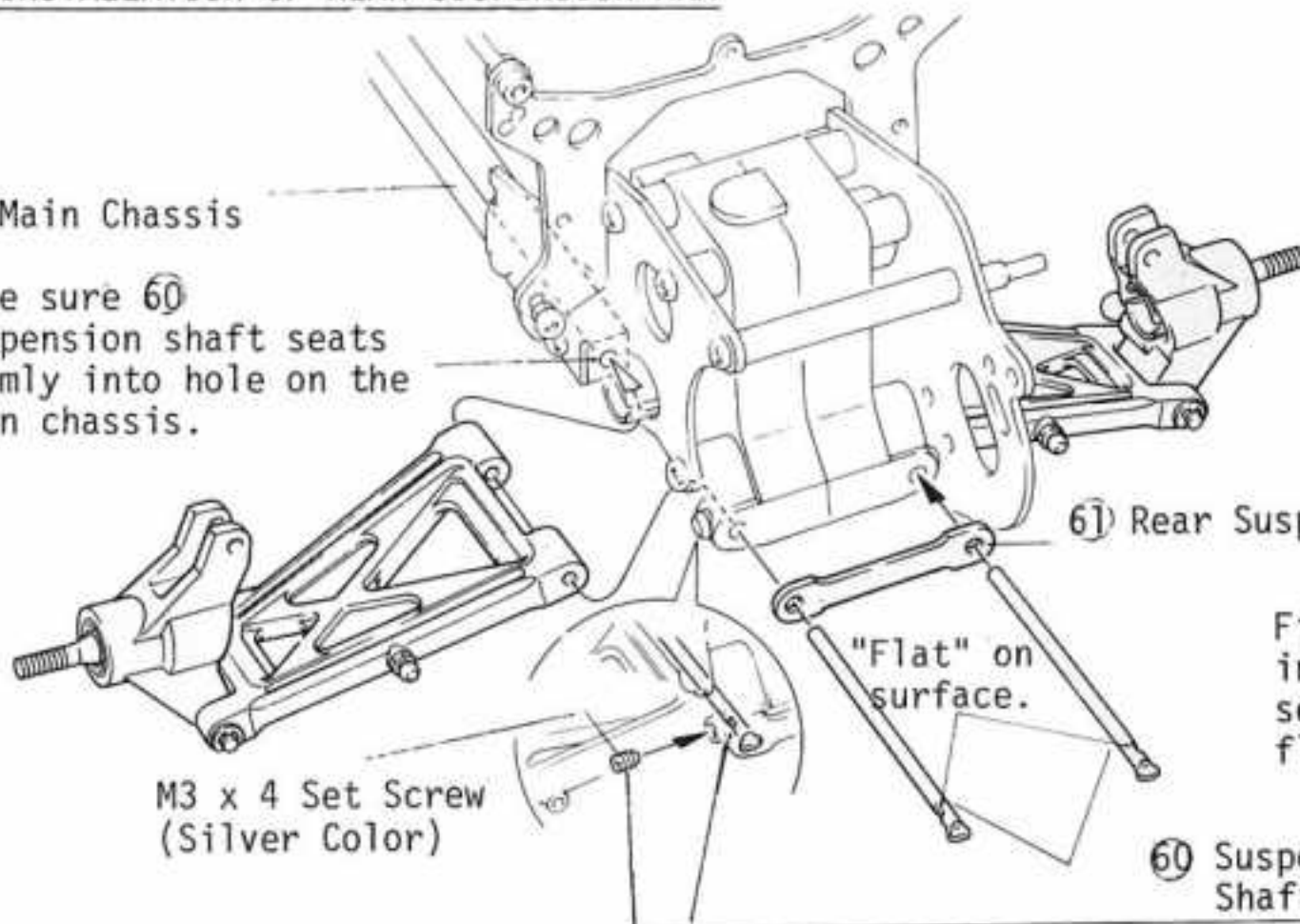

61 Rear Suspension Strut

Fix the suspension shaft in such a way that the setscrew will hit on a flat on the shaft.

M3 x 4 Set Screw (Silver Color)

60 Suspension Shaft (D)

25 INSTALLATION OF REAR UPPER ROD

60 Ball End (L) [Make two Upper Rod]

49 5.8φ Ball

51 Upper Rod

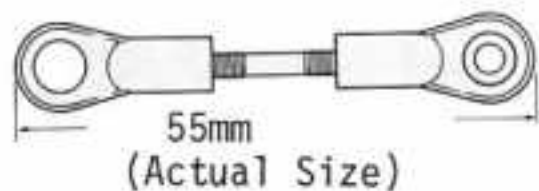

Upper Rod
(Ball inside)

M3 x 10
Screw

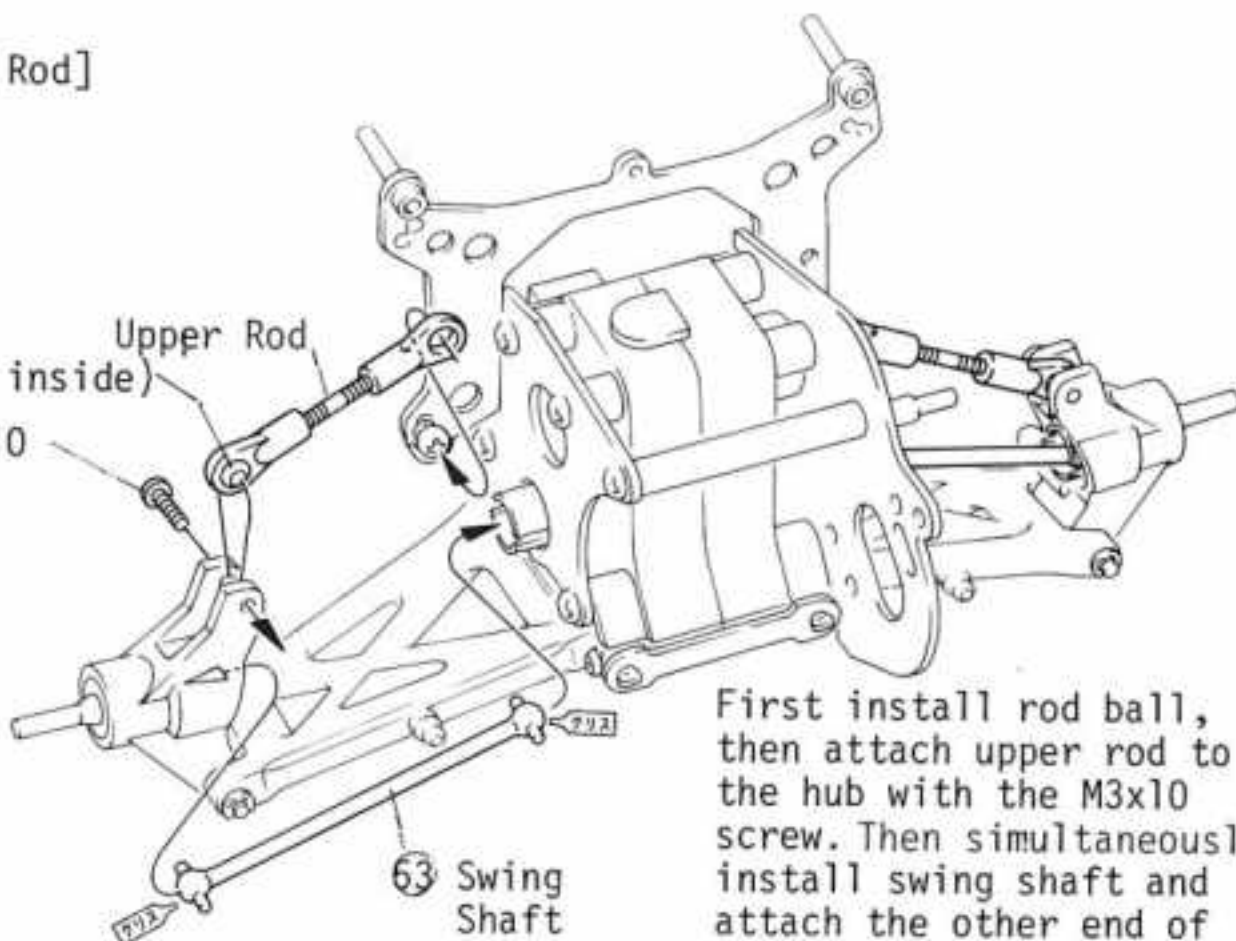

First install rod ball, then attach upper rod to the hub with the M3x10 screw. Then simultaneously install swing shaft and attach the other end of upper rod as shown.

26 INSTALLATION OF REAR SHOCK

154 Shock Fixing Collar
(Red Color)

54 Shock Bush

(Tighten M3 nylon nut firmly but do not crush rubber shock bushing.)

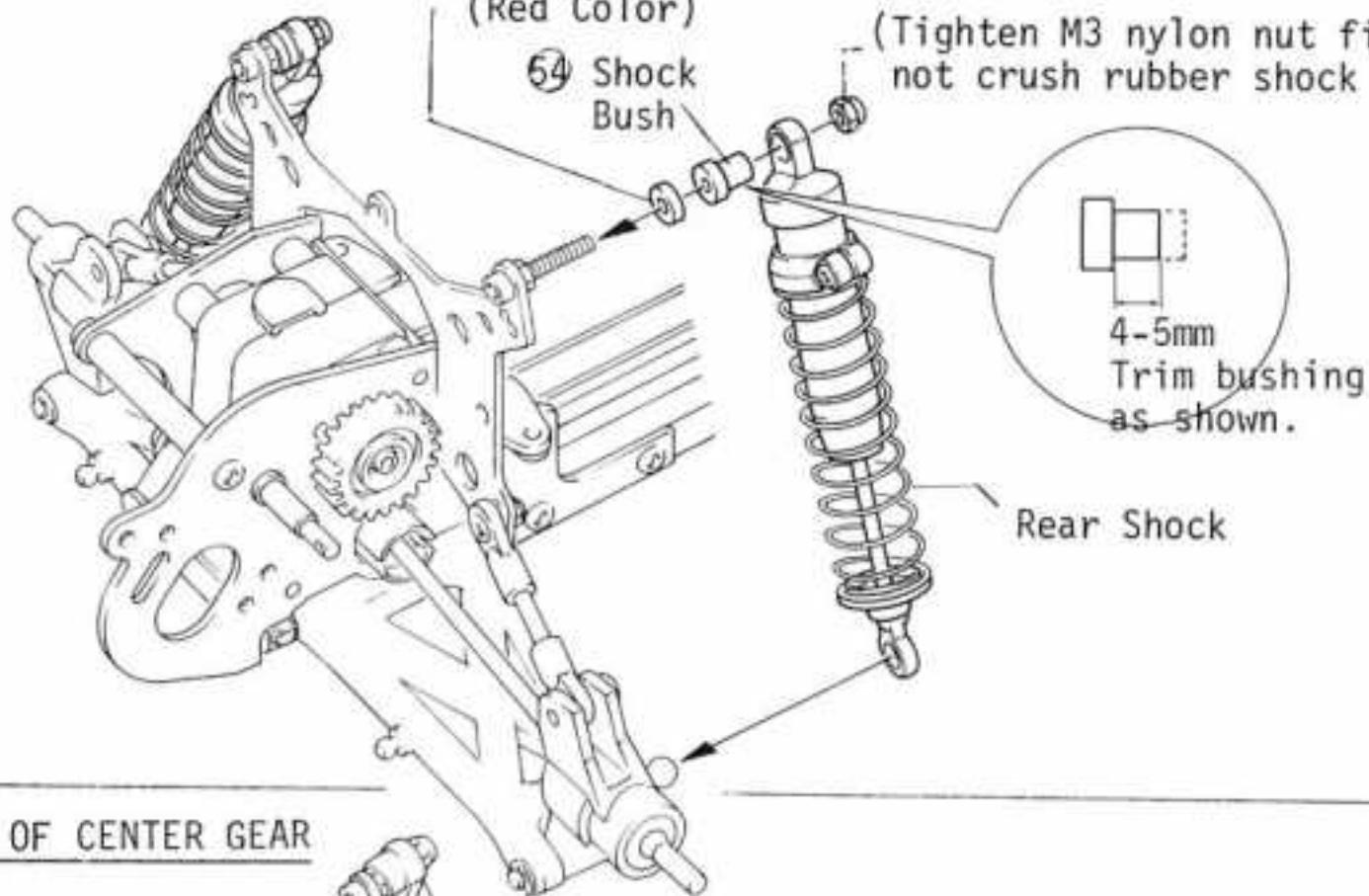

27 INSTALLATION OF CENTER GEAR

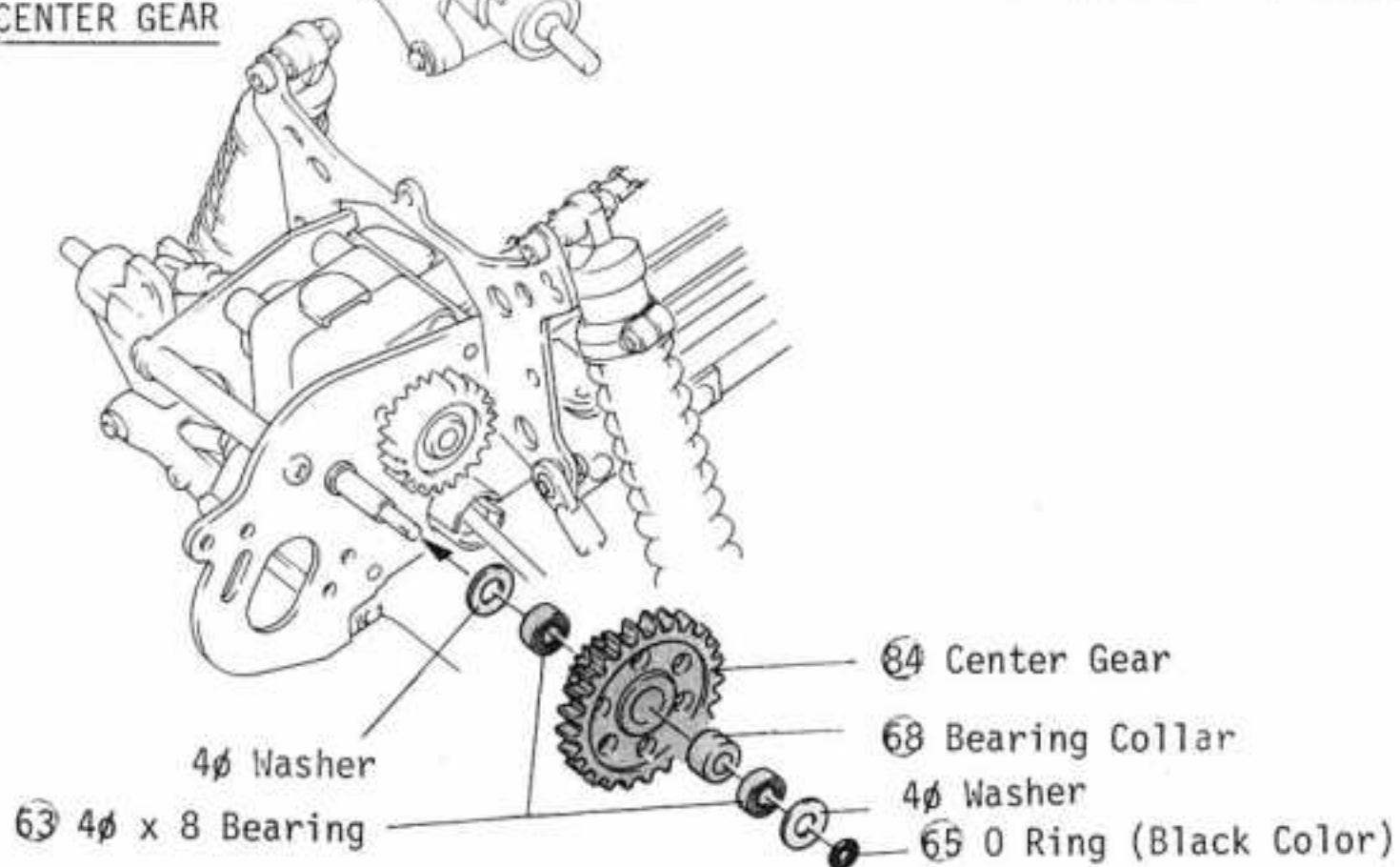

28 INSTALLATION OF MOTOR

[Installation of Motor Cover]

(146) Motor Cleaner

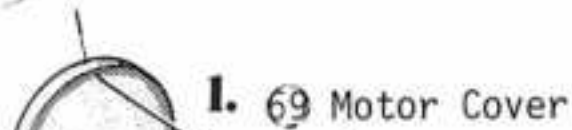

1. 69 Motor Cover

Perforate the side as shown in the drawing before fitting the motor cleaner.

Put rubber cement on striped portion and install it inside of the motor cover.

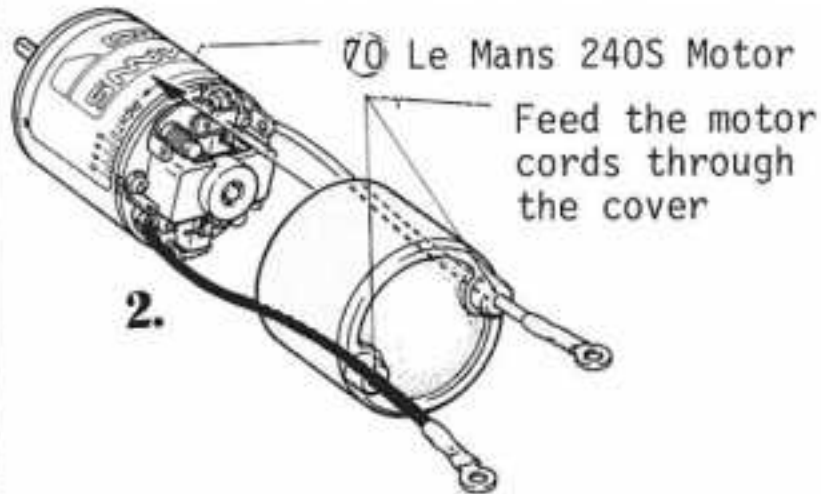

70 Le Mans 240S Motor

Feed the motor cords through the cover

2.

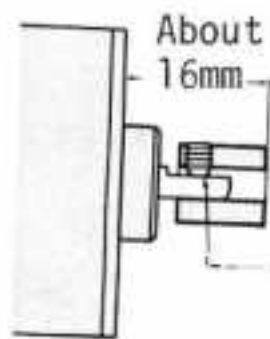

About
16mm

Tighten set screw to flat surface on motor shaft.

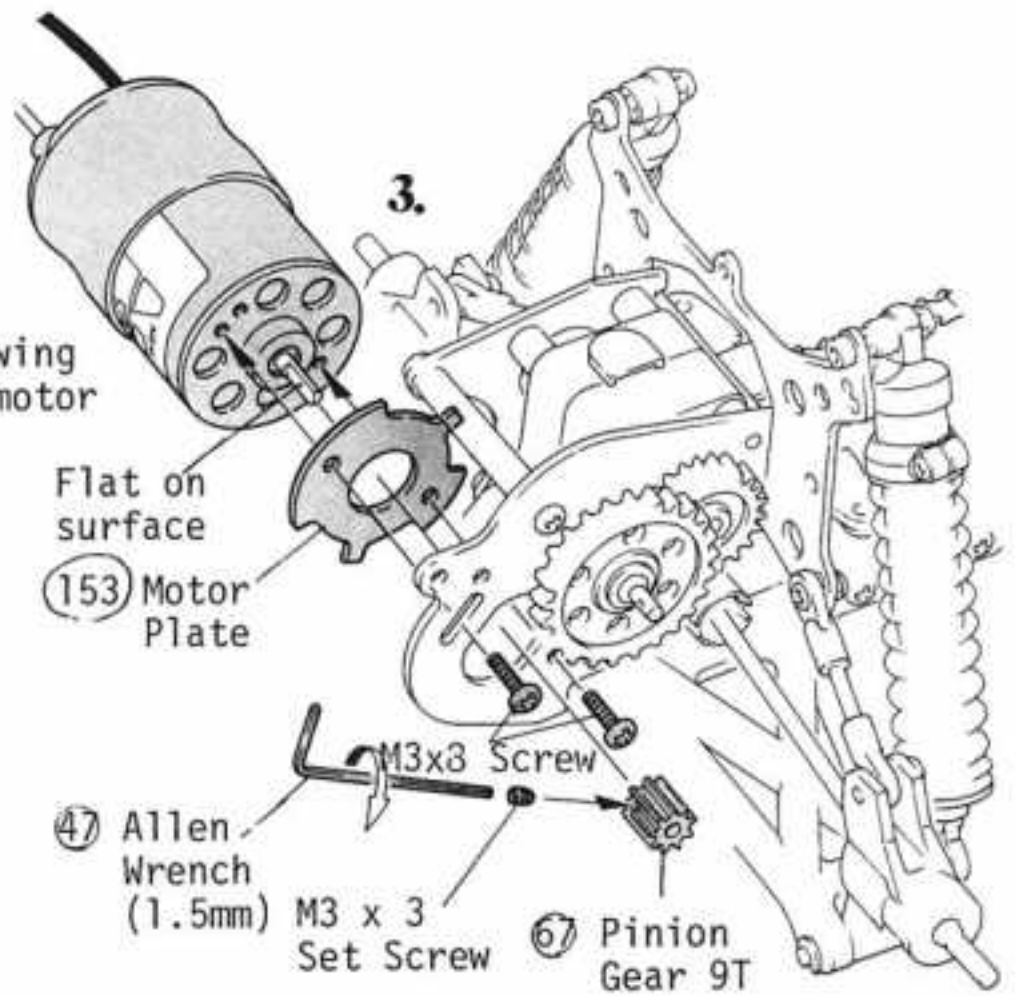

3.

Flat on surface

153 Motor Plate

47 Allen Wrench (1.5mm)

M3x3 Screw

M3 x 3 Set Screw

67 Pinion Gear 9T



[Adjustment of rolling gear]
Adjust gear lash by loosening screws and sliding motor back and forth.

29 INSTALLATION OF GEAR COVER

86 Gear Cover

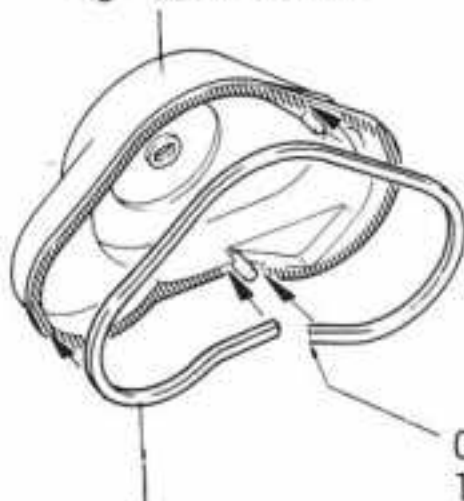

Cut the seal to length.

87 Gear Cover Seal (Home Rubber)

Unseal them from backing and seal them on striped portion.



66 Hook Pin

30 INSTALLATION OF MINI-SIZE SERVO

Tighten very firmly and cut off excess.

88 Servo Spacer (A)
M3 x 6 Flat TP Screw

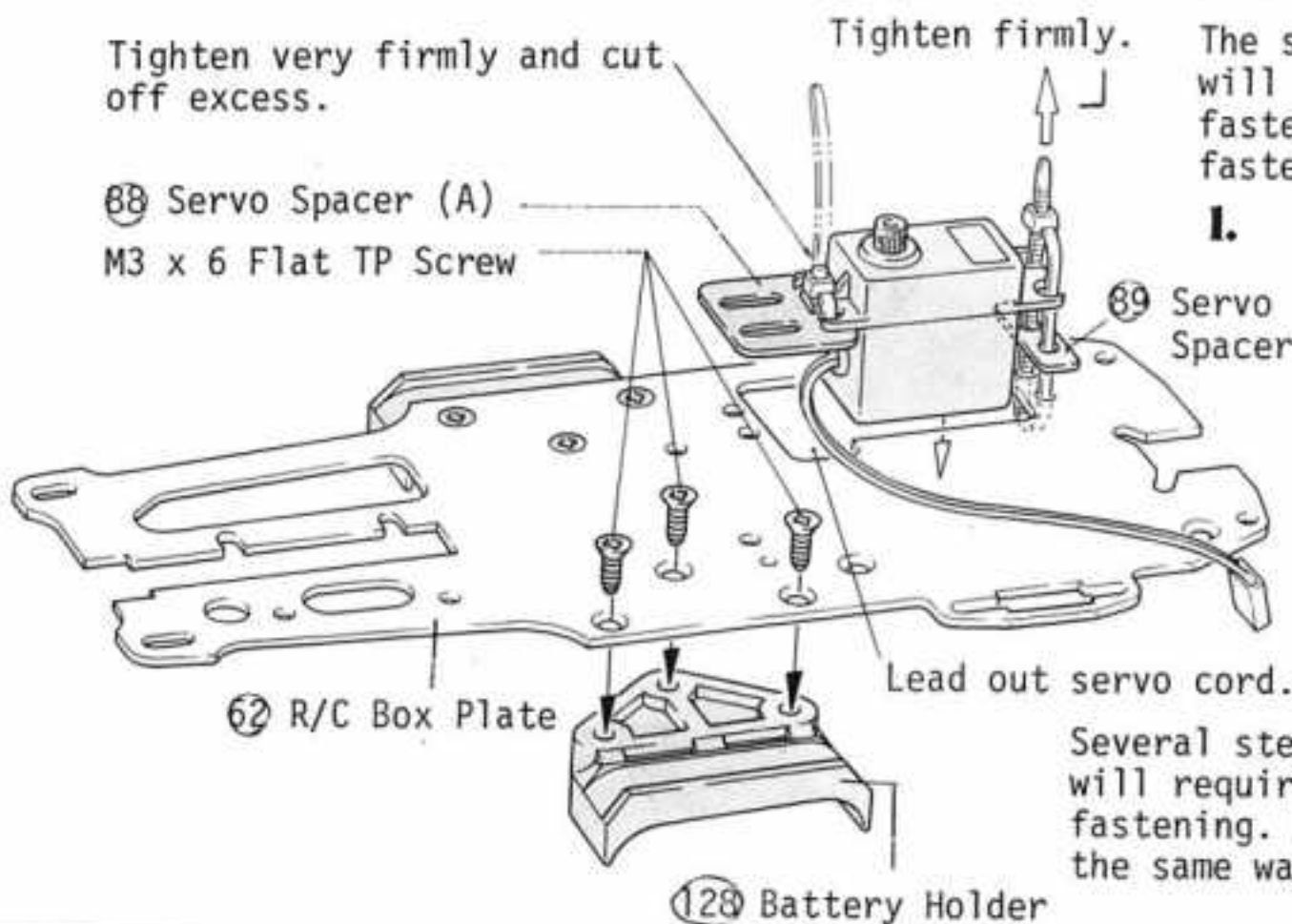

Tighten firmly.

[How to Fasten the Strap (S)]

The strap is so designed that it will not be undone after once fastened. So be sure where to fasten it.

1.

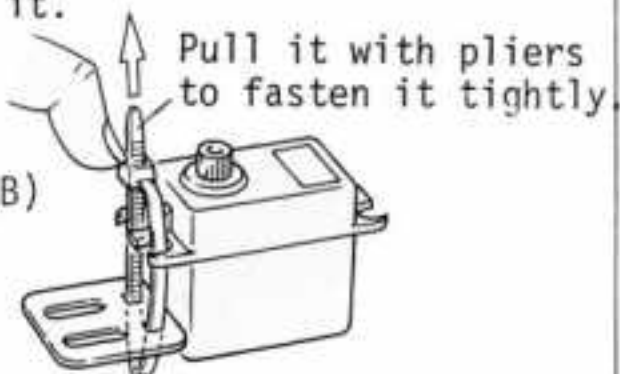

2. After fastening it, cut off the excess portion.



Several steps to come will require the strap fastening. Do it in the same way.

31 INSTALLATION OF MID-SIZE SERVO

When employing any servo listed below, prepare it as shown in the drawing beneath.

Futaba ... FP-S28, FP-S138
Sanwa SM631
KO PS-VM3
JR NES-505

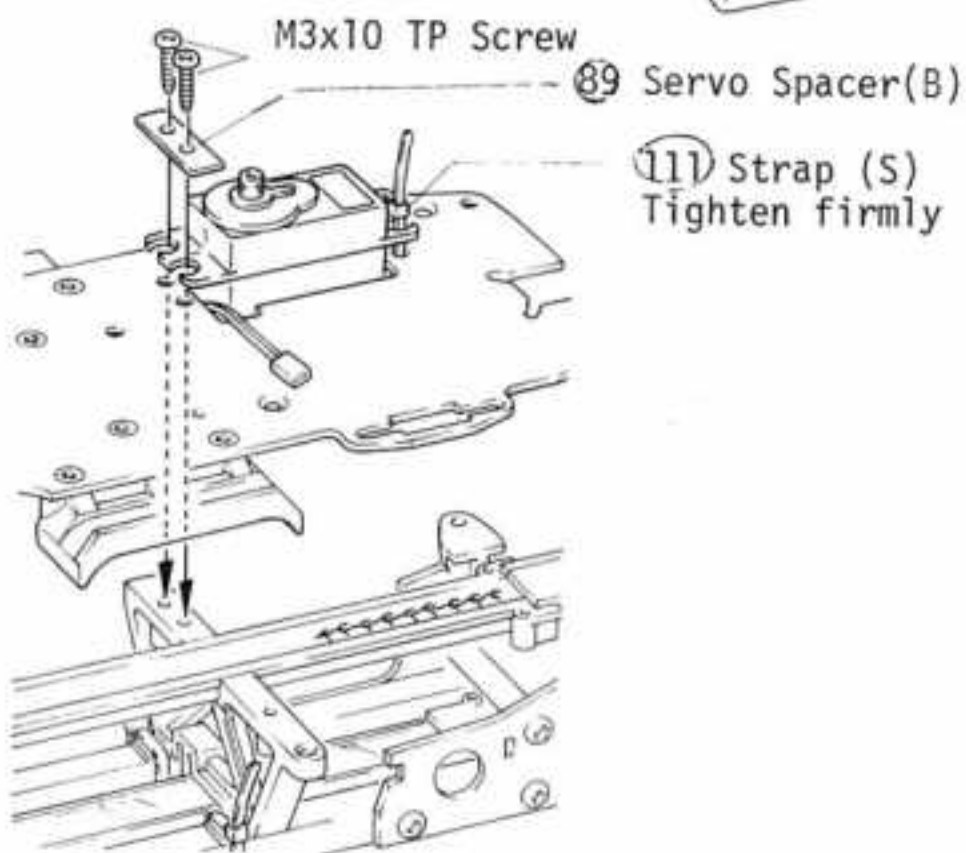
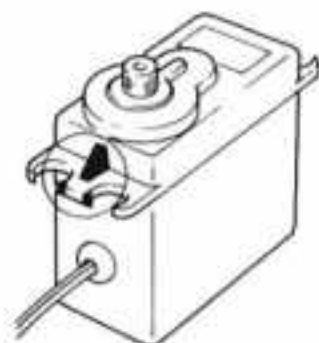
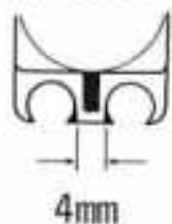

Shave-off excess part with a file.

32 INSTALLATION OF CHAIN GUIDE(A)

M2 x 8 TP Screw

100 Chain Guide (D)

Bend the chain guide (A) as shown and install front end first.

Note Tab

Tab

100 Chain Guide (A)

NOTE: To protect chain from contamination by dirt and dust, caulk between chain guide and cover with silicone caulk.

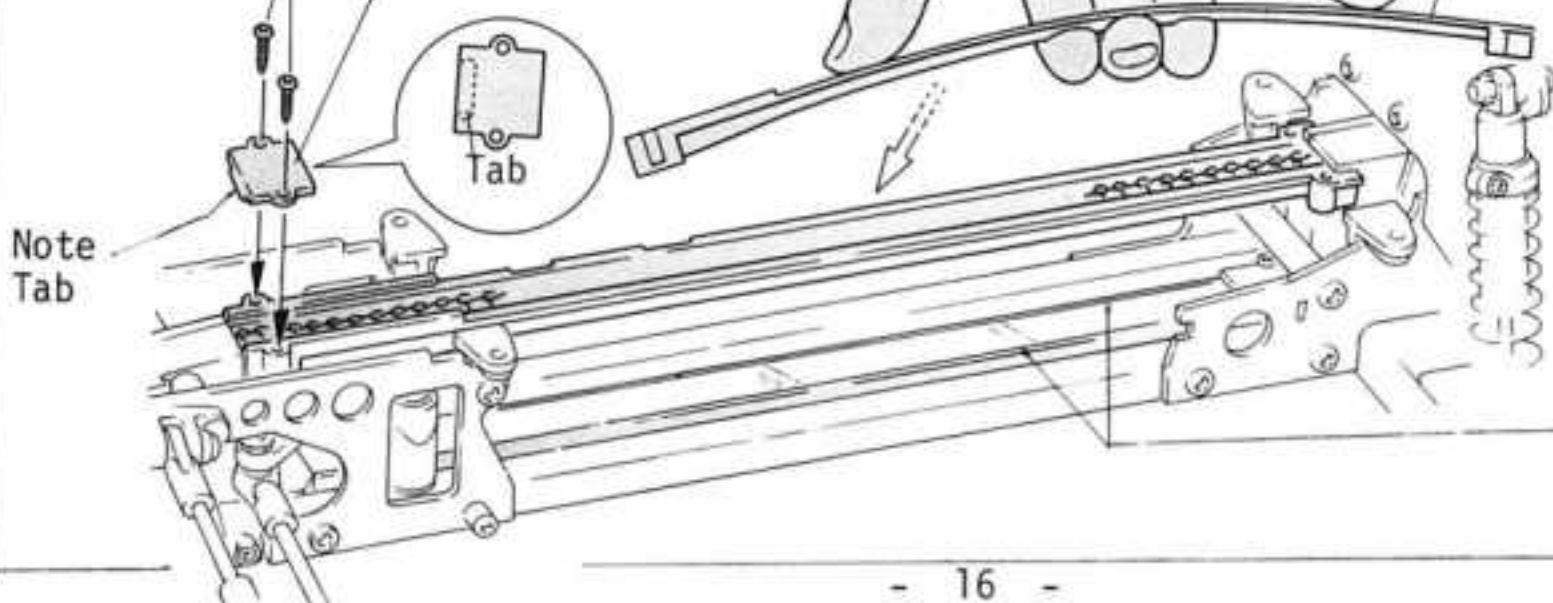

33 MOUNTING RADIO PLATE

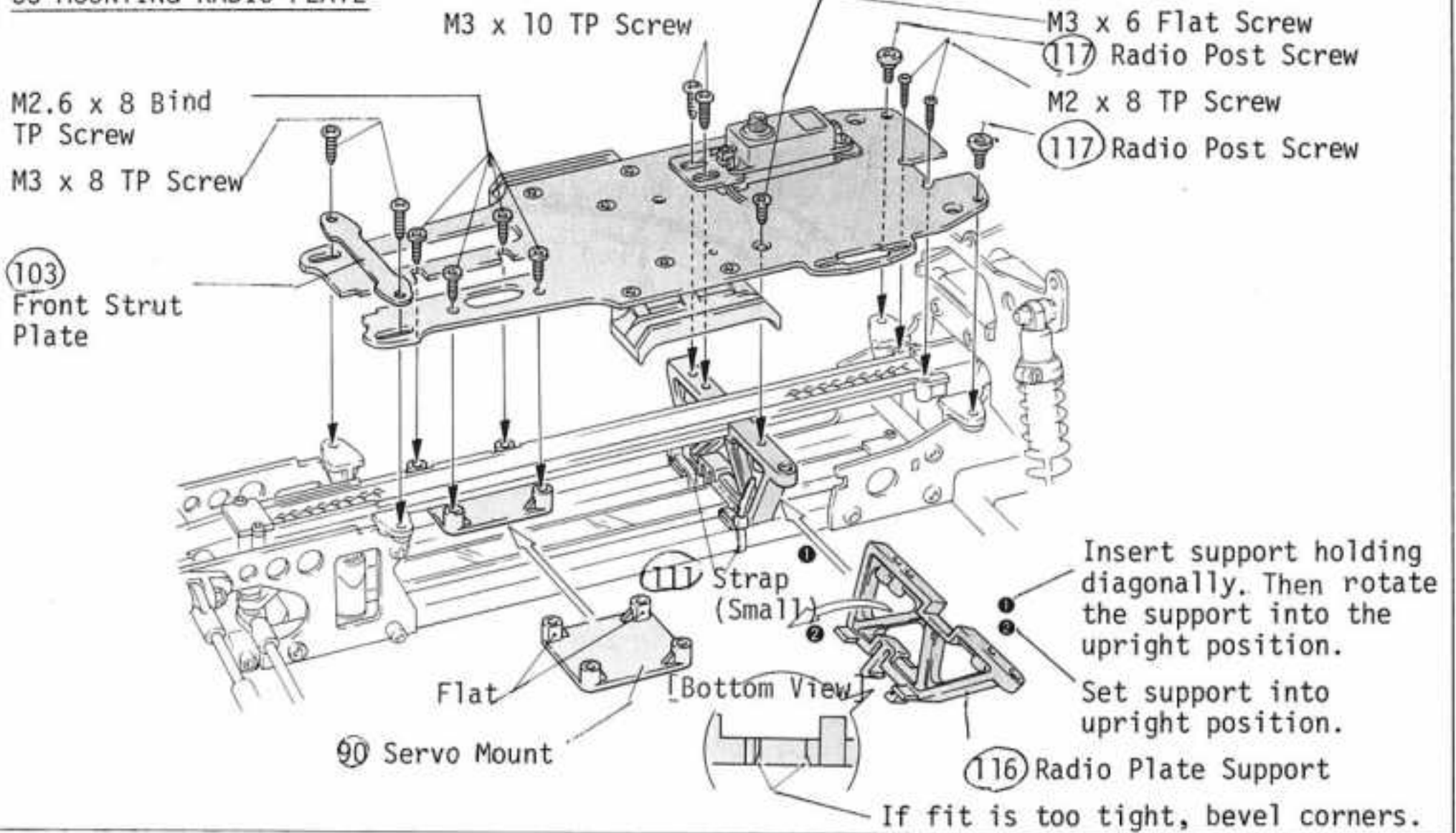

34 INSTALLATION OF CHASSIS GUARD

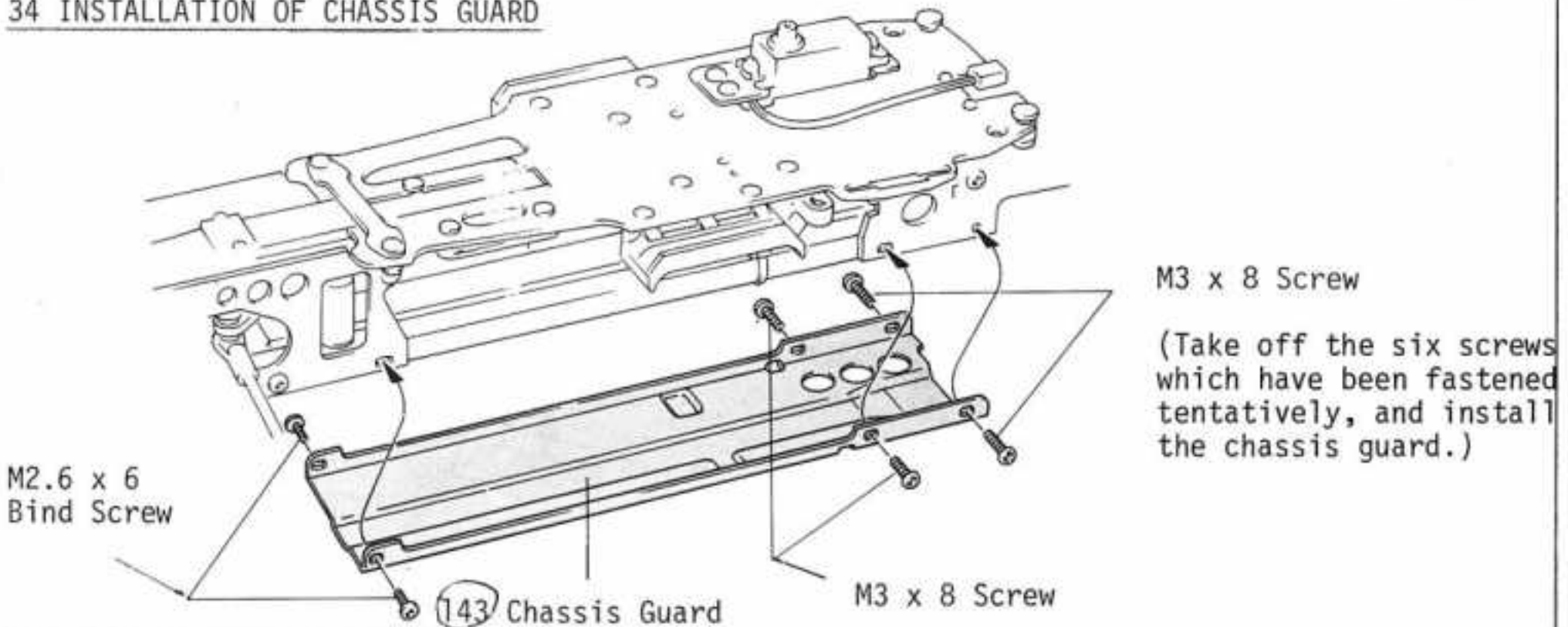

35 FIXING OF CEMENT RESISTOR

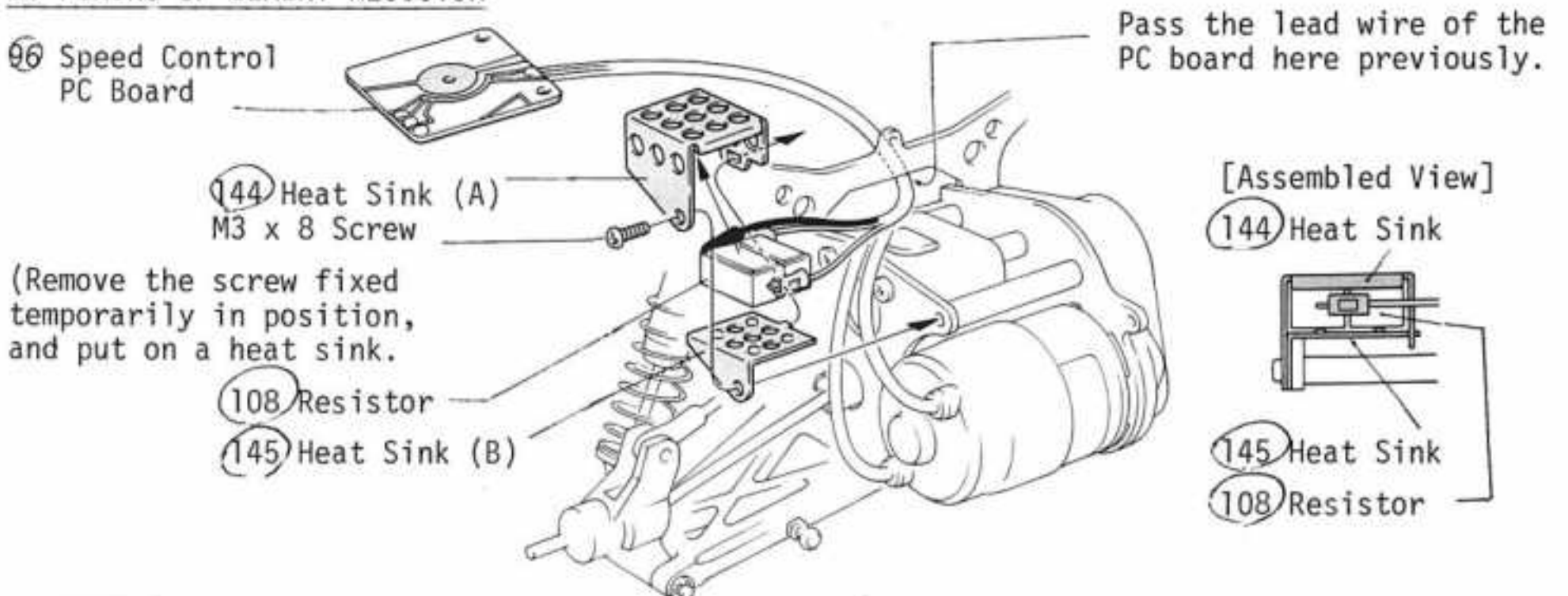

36 INSTALLATION OF SPEED CONTROL

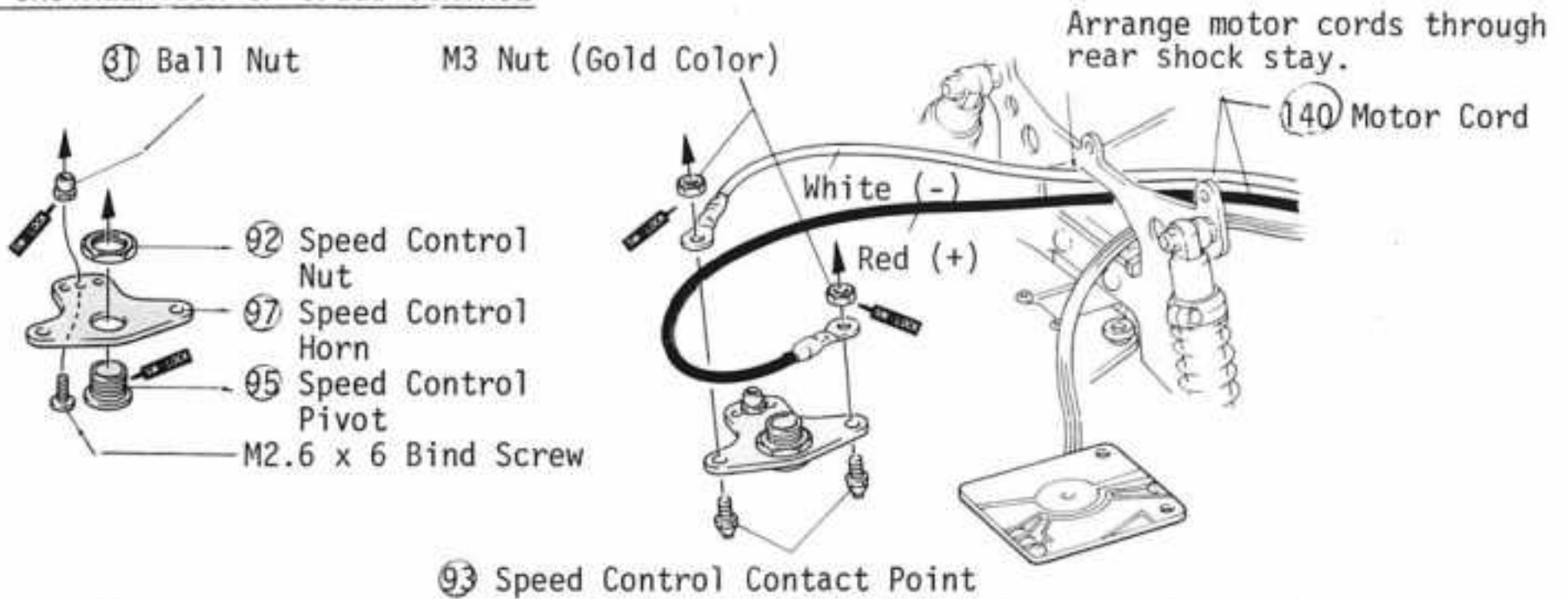

37 WIRING OF RECEIVER BATTERY

[For those who use a BEC type radio, please skip the step 37, and proceed to the next step.]

NOTE: The battery that powers the motor also powers the receiver. Use great care and do not allow polarity to be reversed. Also, do not allow 8.4V to flow directly into receiver. The colors of the lead wires are different depending upon radio manufacturer. Most use red for positive (+) and black for negative (-). The exception being Cox and Airtronics (Sanwa). Their (+) lead has a white stripe and the middle lead is (-).

1. Cut off wires from radio box as shown.

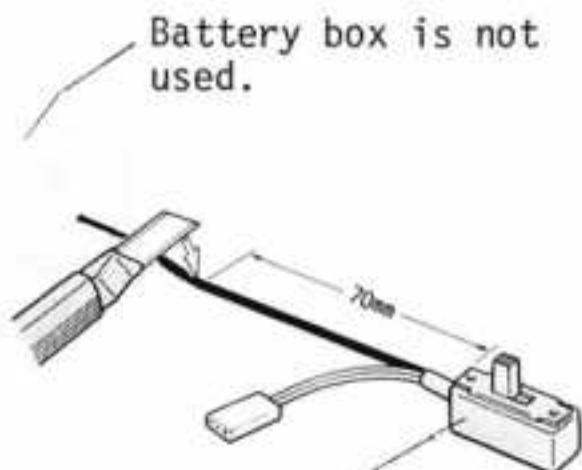

Use the switch harness which is provided with your radio.

2. Connect the leads from the R/C unit switch and the regulator.

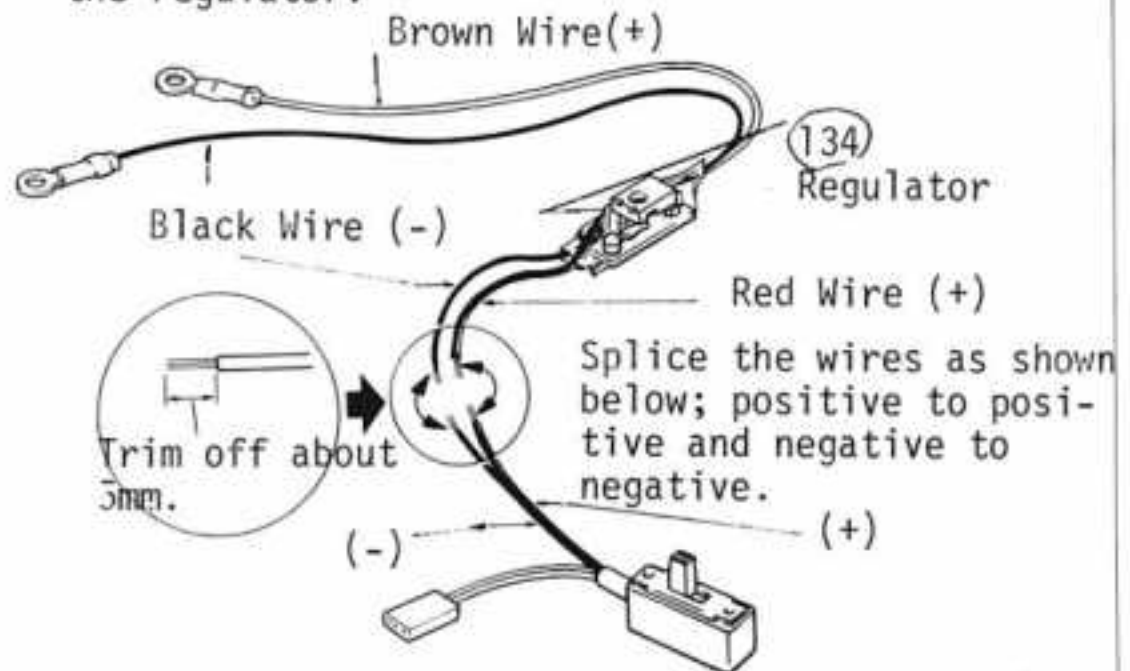

- ① Join wires by twisting together.



- ② Insulate the connection points with vinyl tape to prevent a short-circuit.

*For ensuring the job, solder the spliced leads.

38 INSTALLATION OF SPEED CONTROL PC BOARD

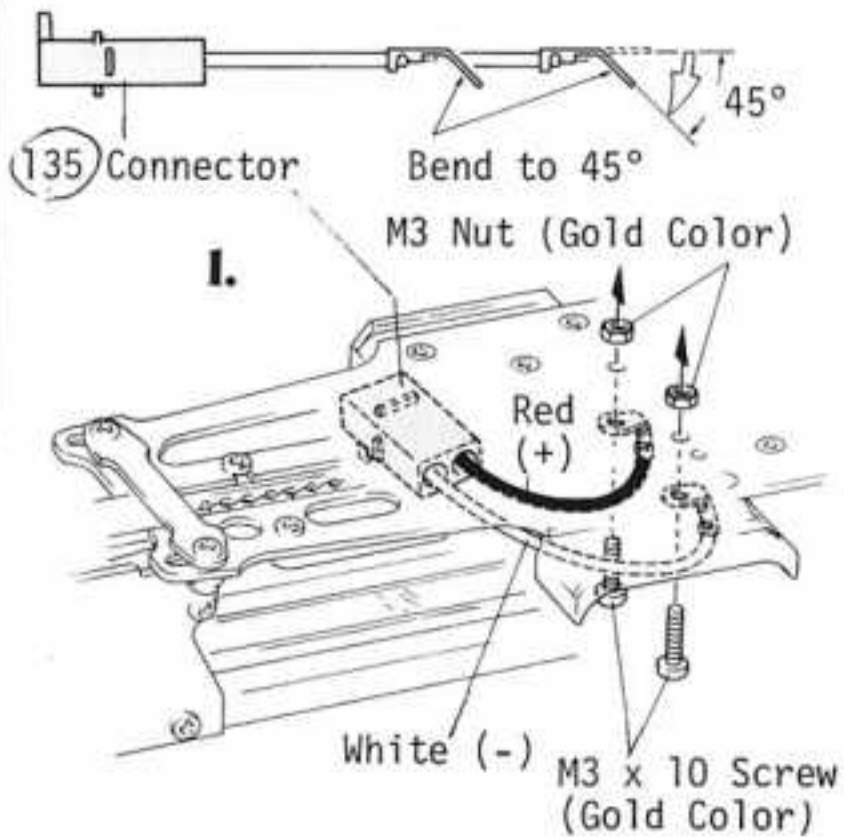

NOTE: Fix the connector terminals under the radio plate.

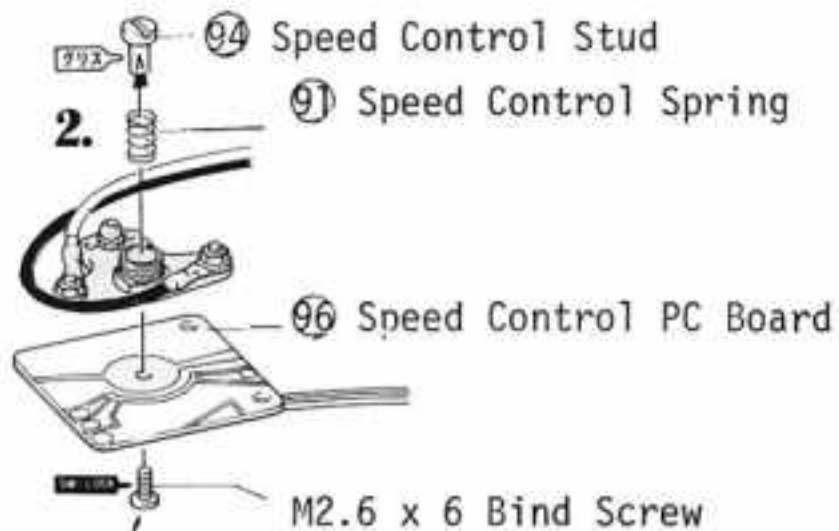

Cement this screw to the PC board with cyanoacrylate adhesive or "Locktite" so that it won't turn idle.

M3 Nut (Gold Color) 98 Driver Post

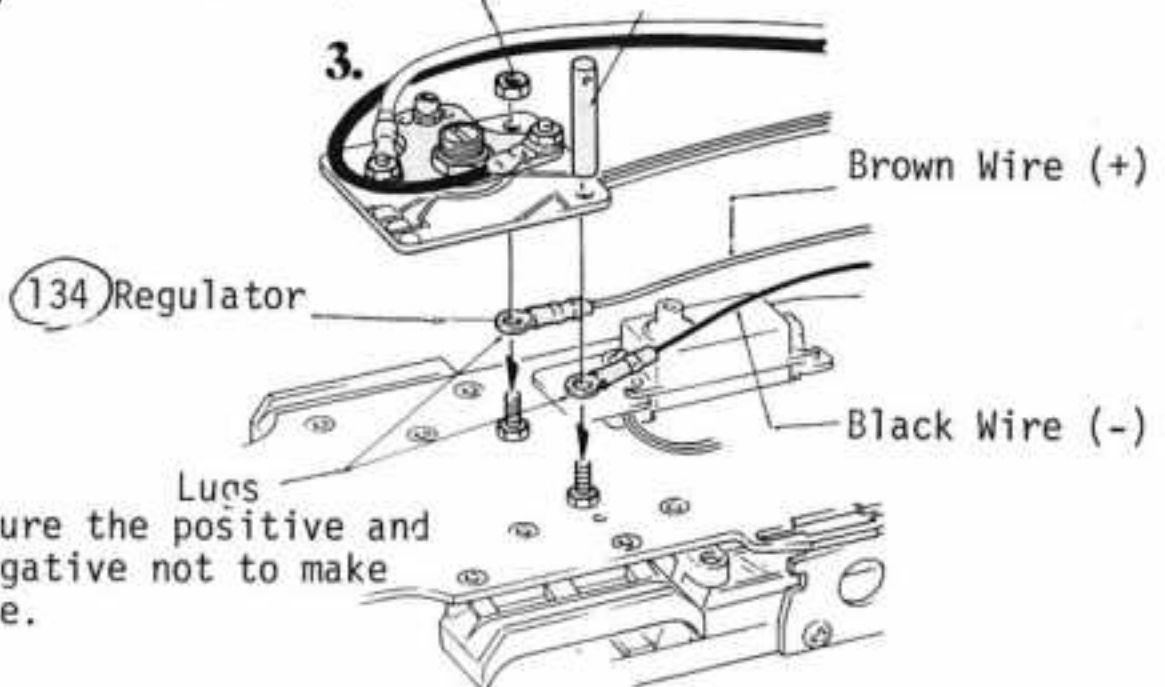

Make sure the positive and the negative not to make mistake.

39 WHEN THE BEC RADIO IS EMPLOYED



The radio contained in the box with this logo is the BEC type. As shown in step 37 on page 18, the radio does not use the regulator (30), also the wiring for the switch is not required. When using this type of radio, fix the BEC connector as illustrated below.

NOTE: When arranging the BEC connector, do not mistake the positive (red cord) with the negative (black cord). The improper polarity may damage the radio.

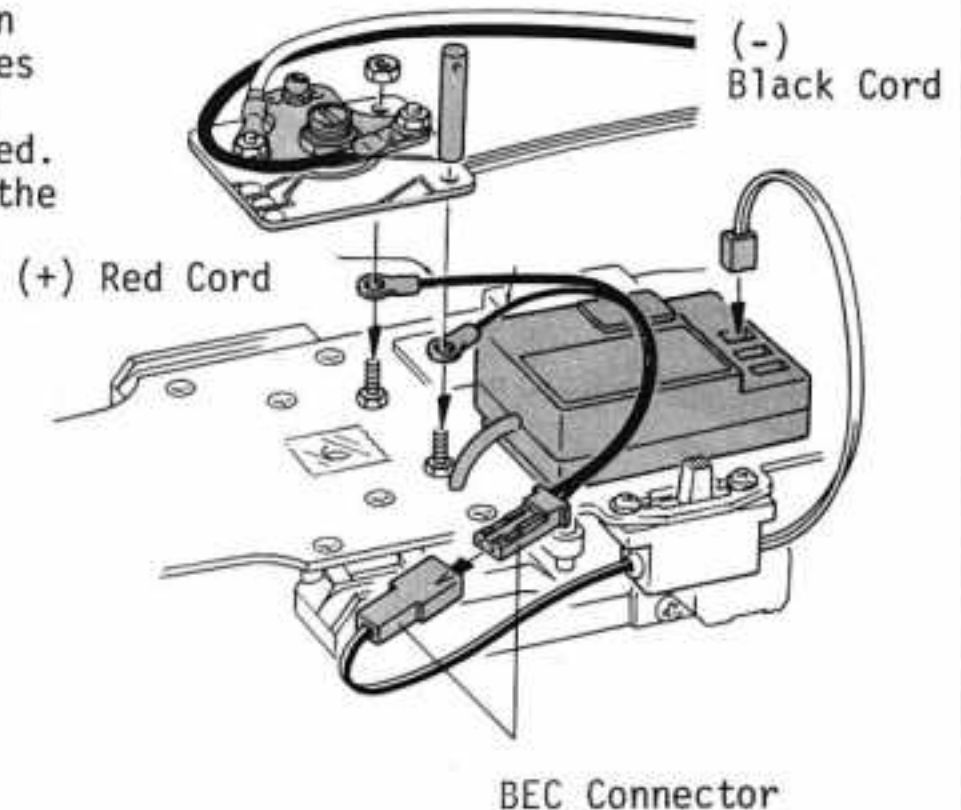

40 SPEED CONTROL LINKAGE

Trim the shaded portion from your servo horn.

Hole may have to be enlarged slightly.

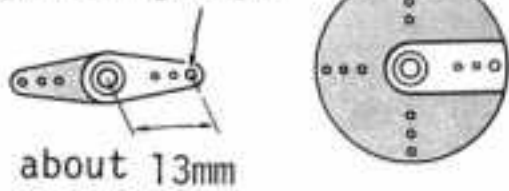

Install ball end onto (104) Servo Rod.

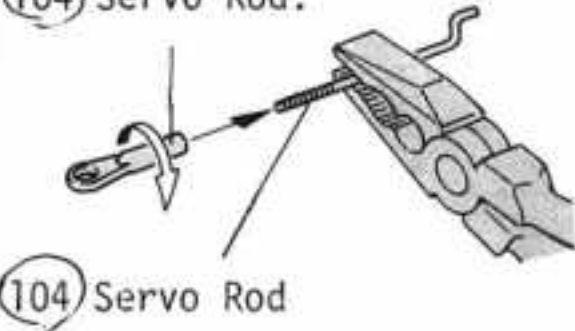

Use the screw included with your radio.

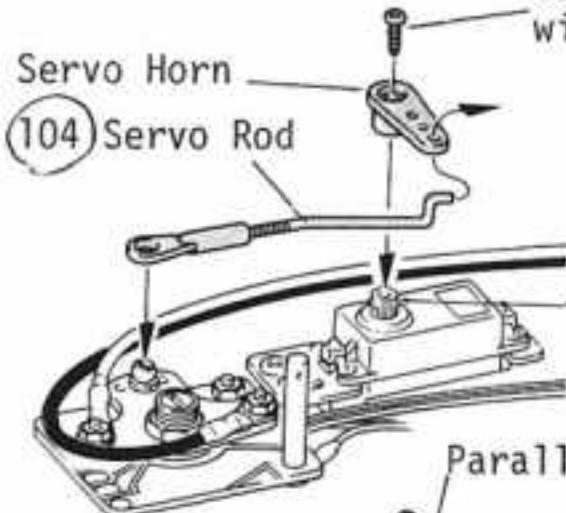

Keep servo in neutral position.

Arrange cords and tie with strap.

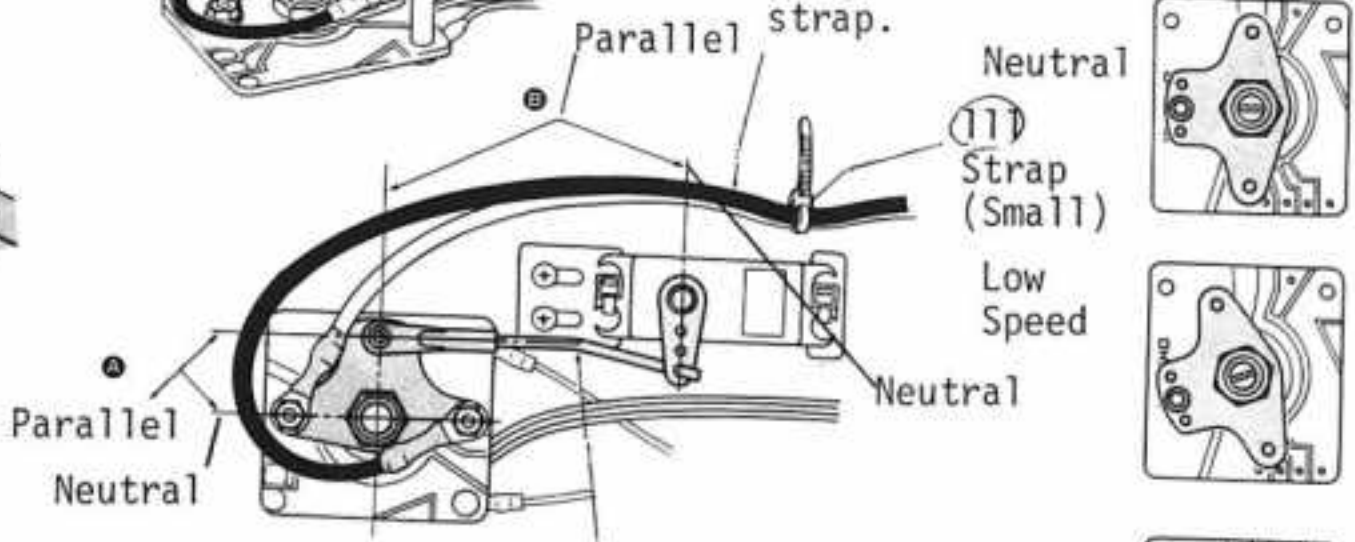

Achieve the parallel adjustment indicated by turning ball end.

Turn the ball end. Getting longer

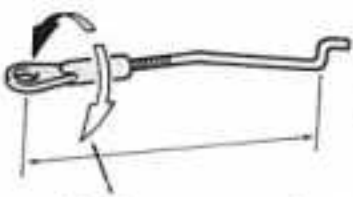

Reverse

It become shorter.

Neutral

(111) Strap (Small)

Low Speed

Medium Speed

High Speed

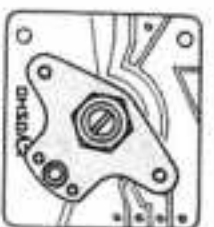
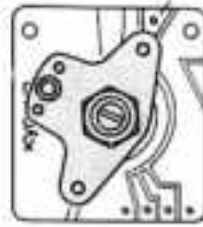
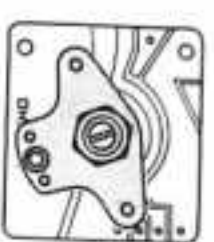

41 INSTALLATION OF STEERING ROD

Trim the shaded portion from your servo horn.

Hole may have to be enlarged slightly.

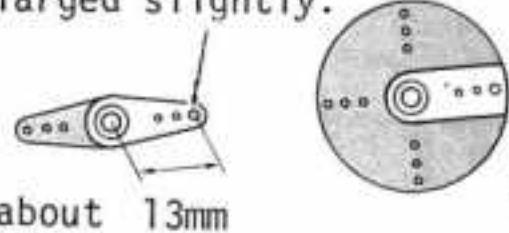

(37) Ball End (Small)



(113) Steering Rod

[Affixing Double-Sided Tape]

[Cutting Double-Sided Tape]

(106) Double Sided Tape (Actual Size)

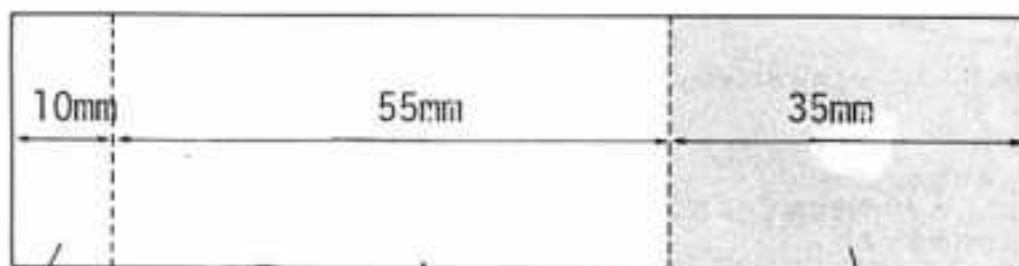

For regulator

For Receiver (This portion will be used in step 43.)

For Steering Servo

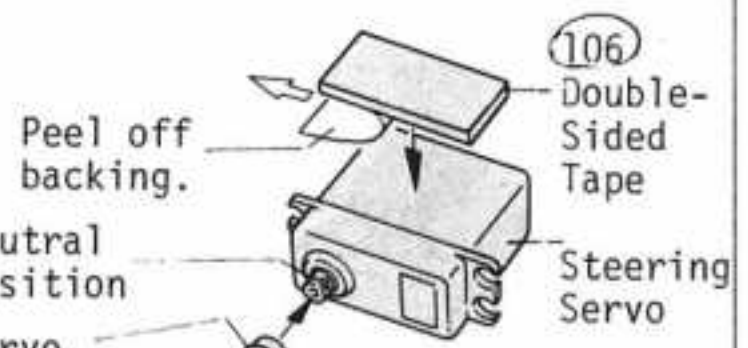

Use the screw included with your radio.

(113) Steering Rod



42 STEERING CONTROL LINKAGE

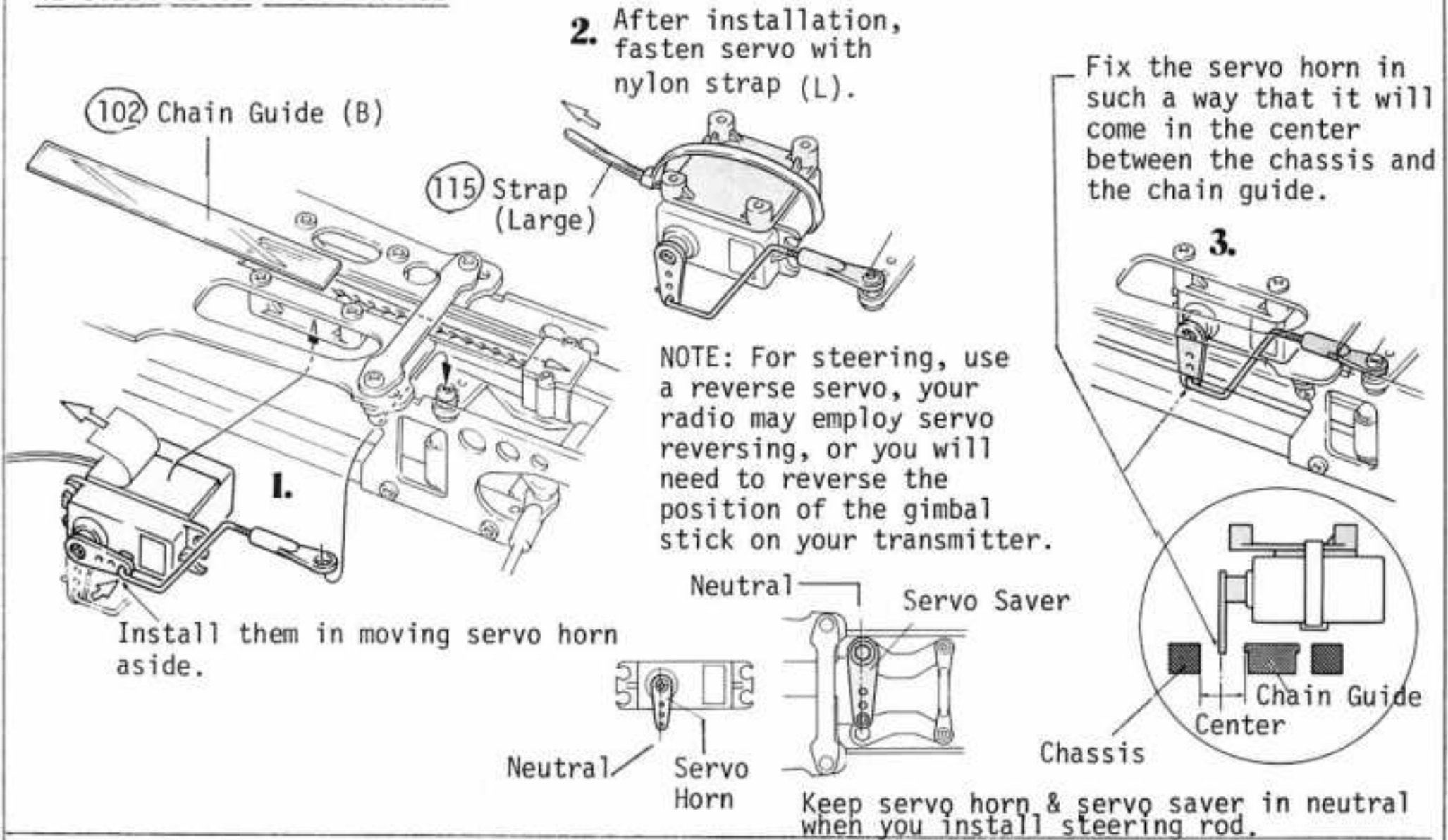

43 INSTALLATION OF RECEIVER AND ANTENNA

Put the pieces of double-sided tape, which was cut in step 41, under the receiver and the regulator.

2. Fix the regulator in such a position that it will be housed in the head of driver doll, which will be worked later in step 52.

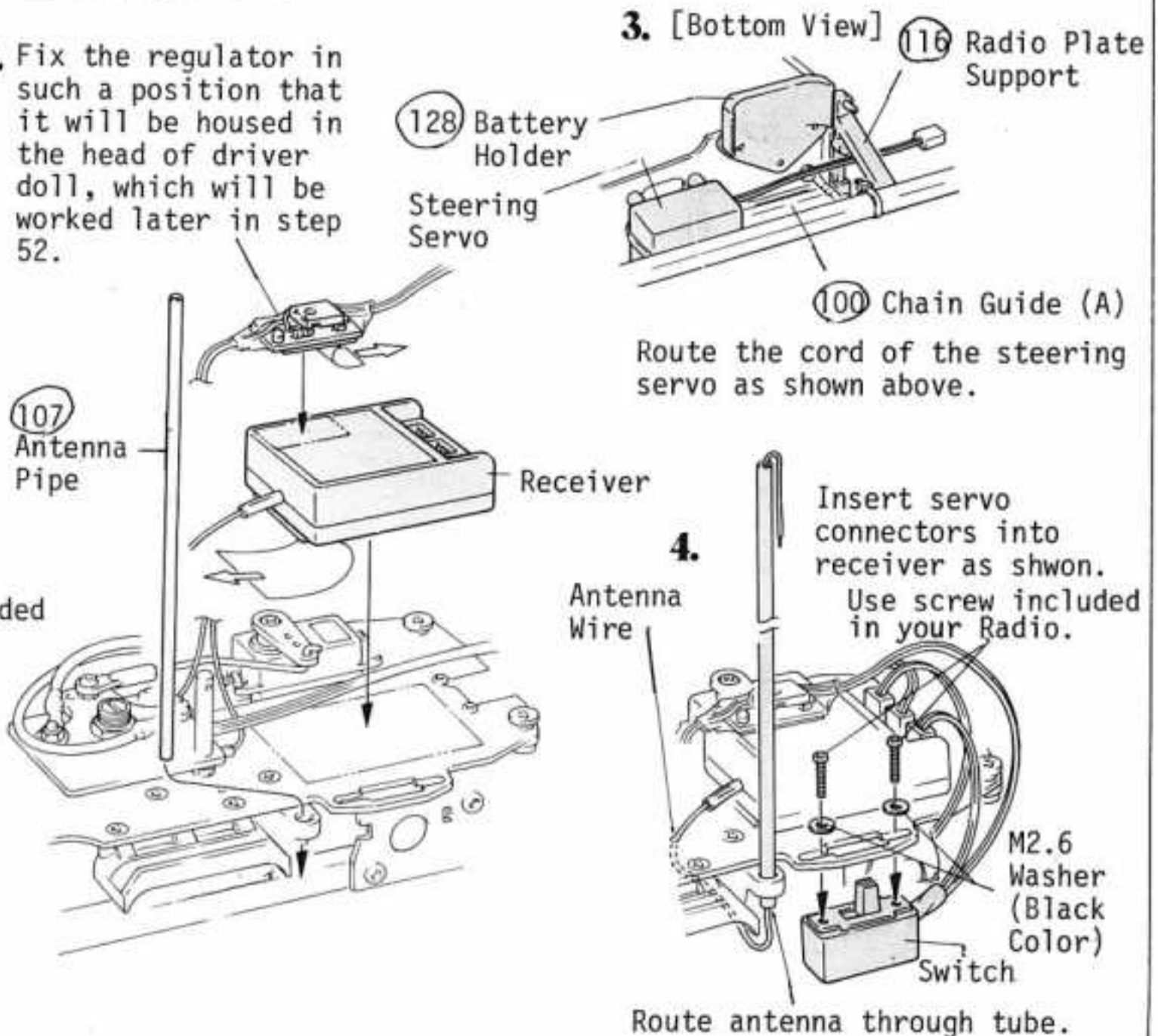
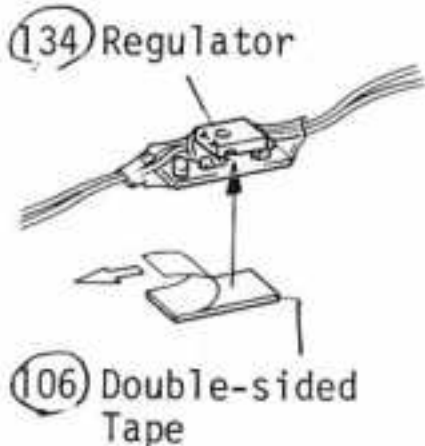
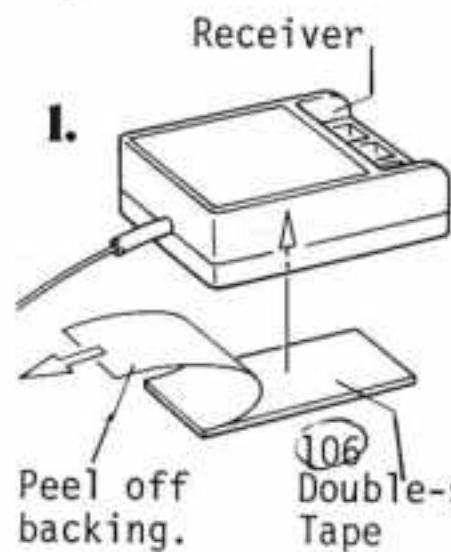

44 INSTALLATION OF FRONT STABILIZER

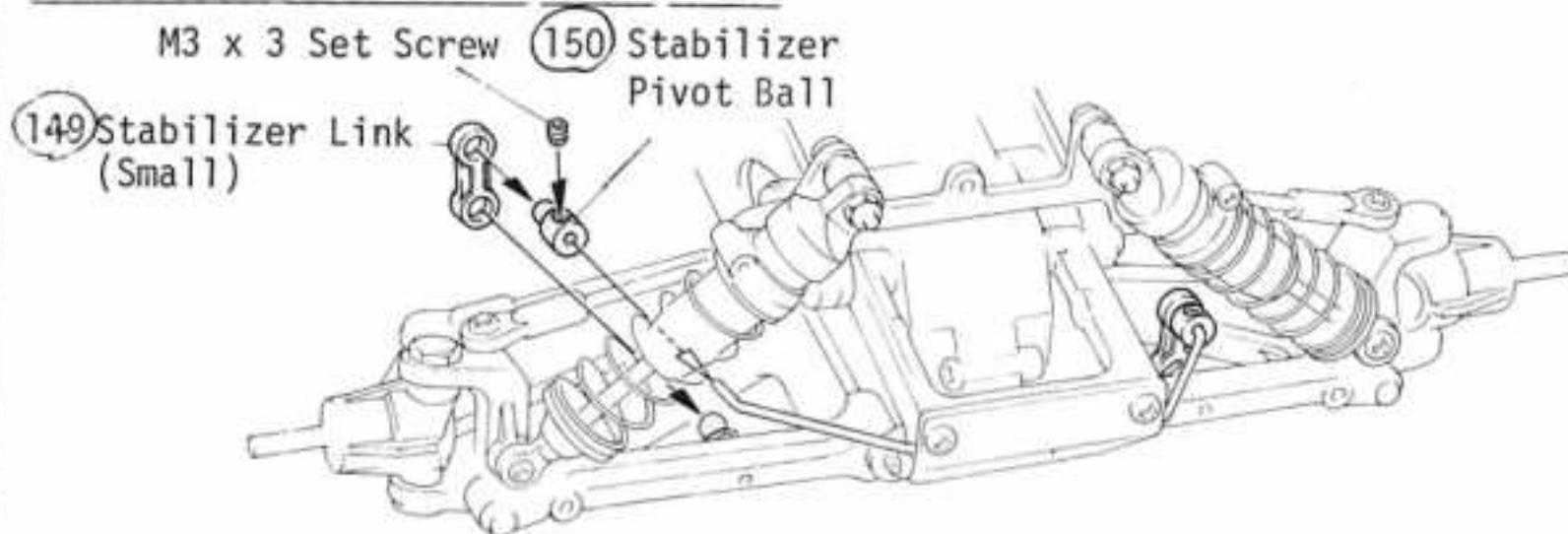

45 INSTALLATION OF REAR STABILIZER

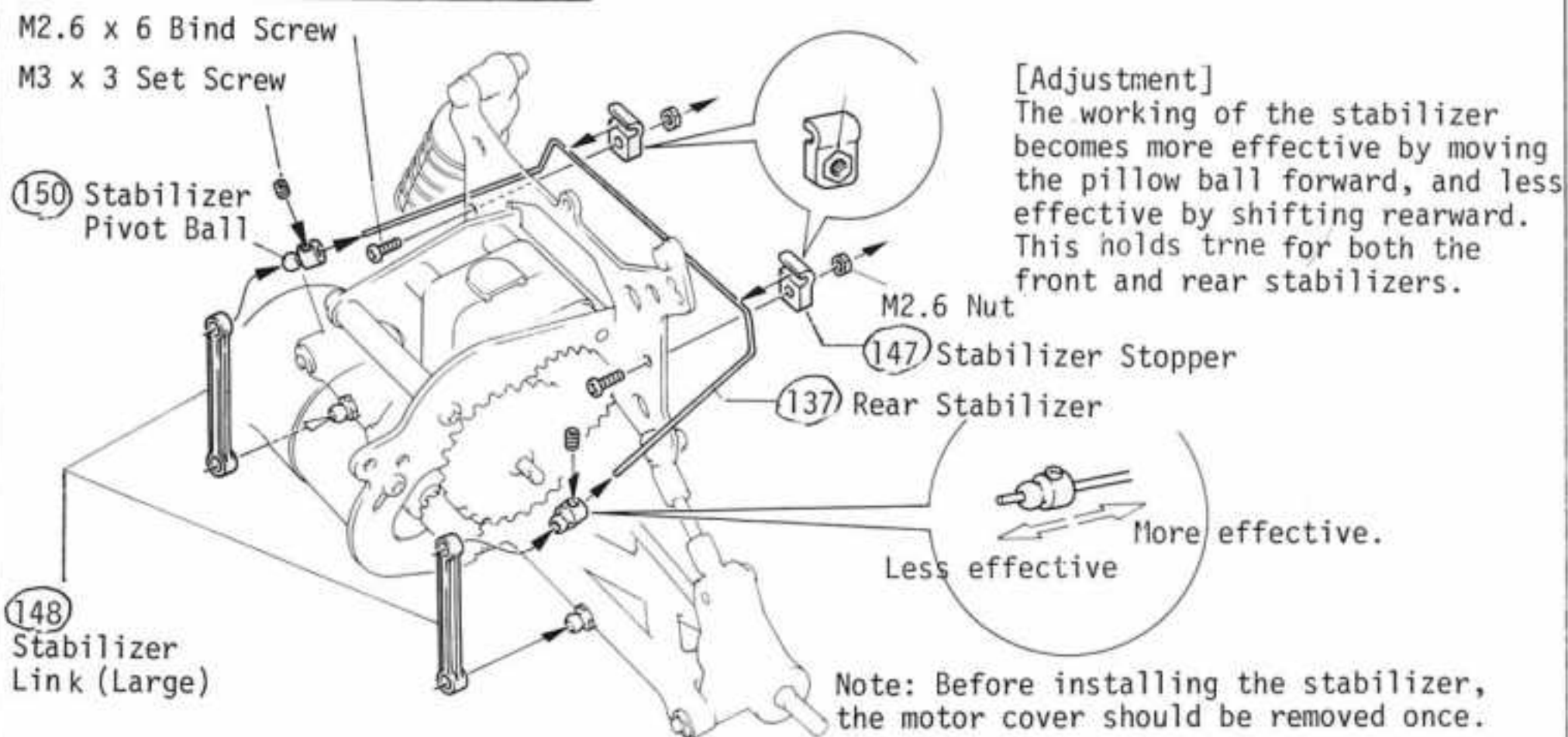

46 INSTALLATION OF BUMPER

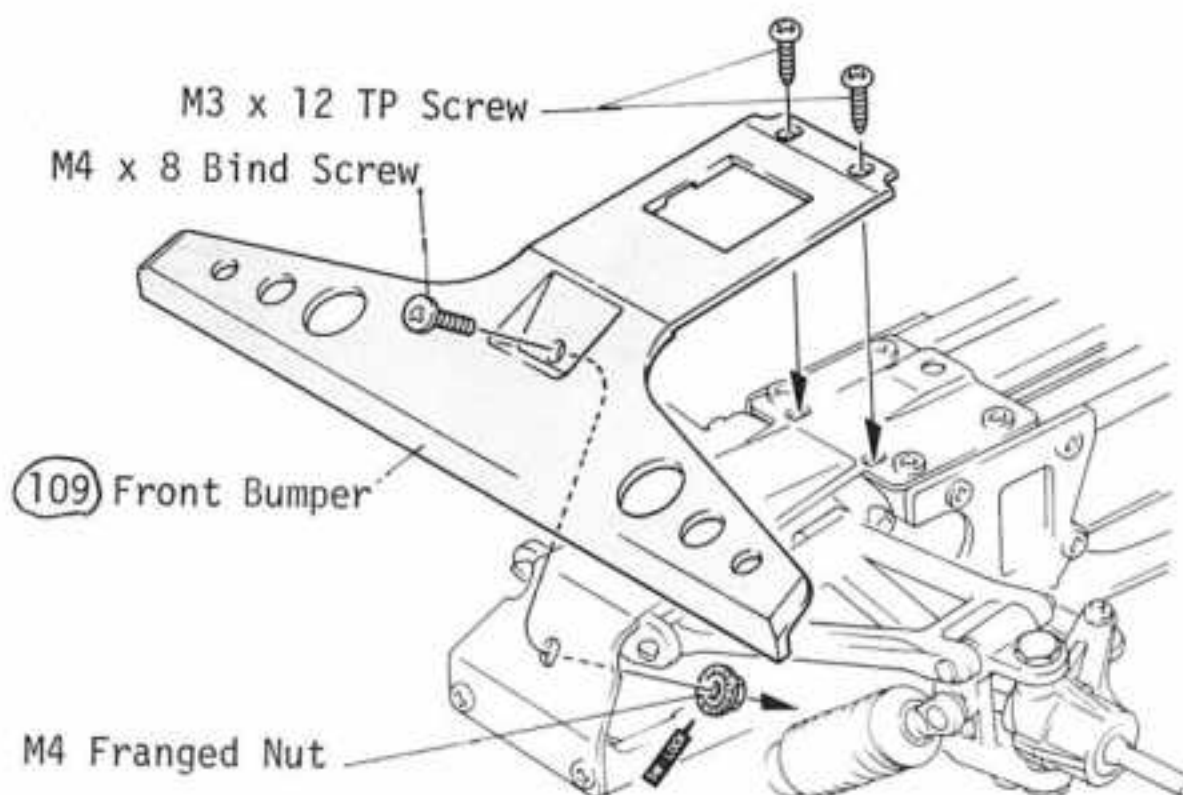

47 MOUNTING THE WHEEL

Insert (3) Wheel (2) inside of (1) Tire as below picture.

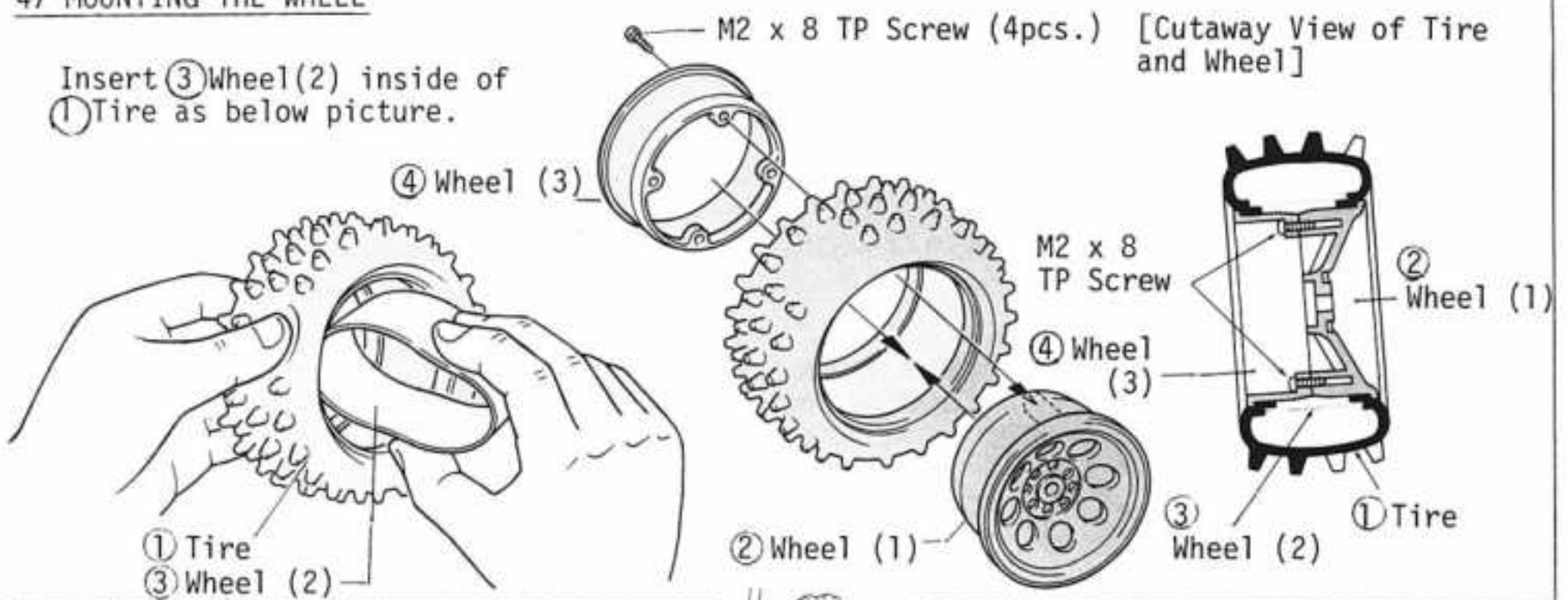

48 INSTALLATION OF TIRES

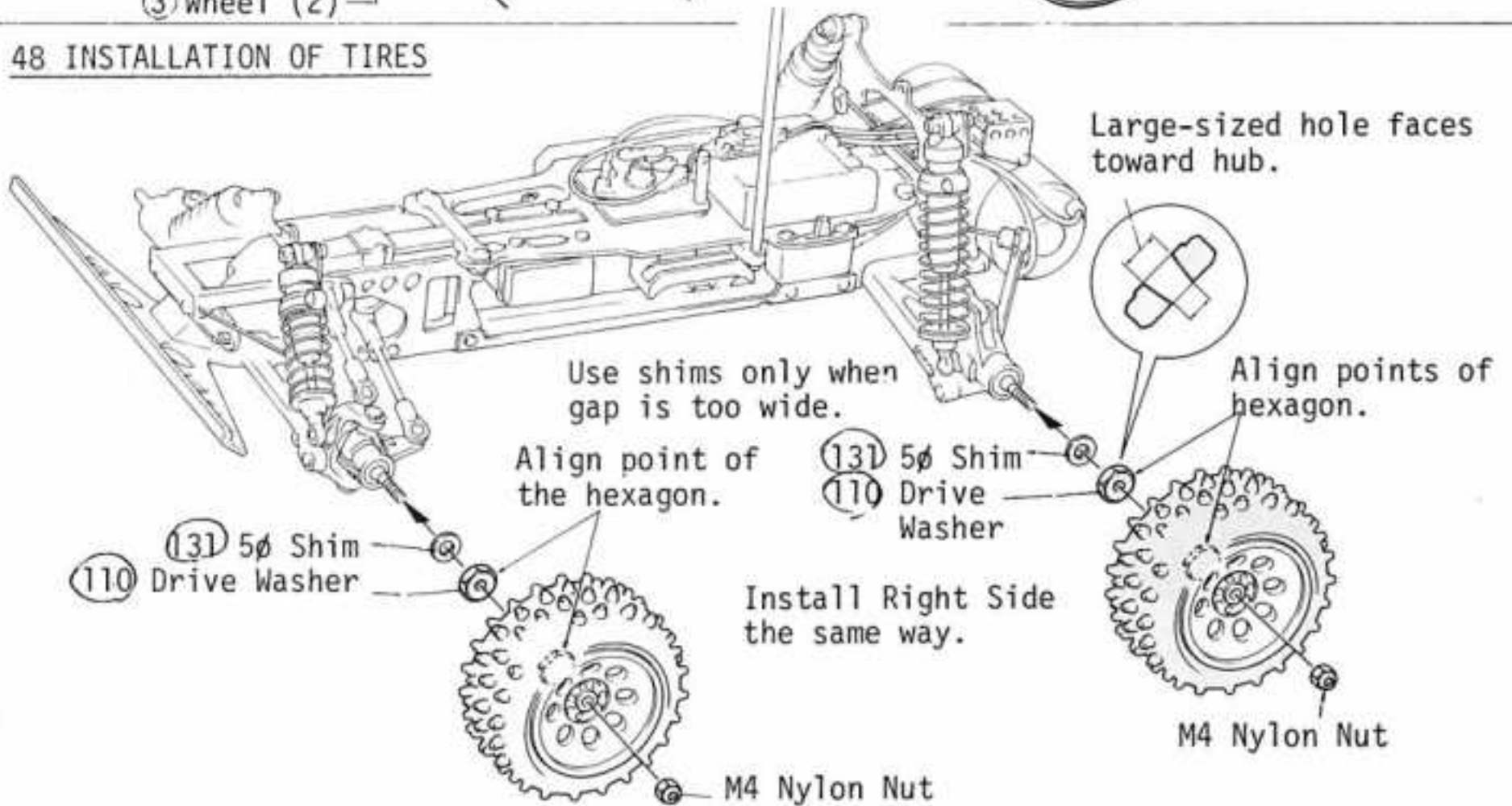

49 CUTTING OUT BODY AND DRIVER

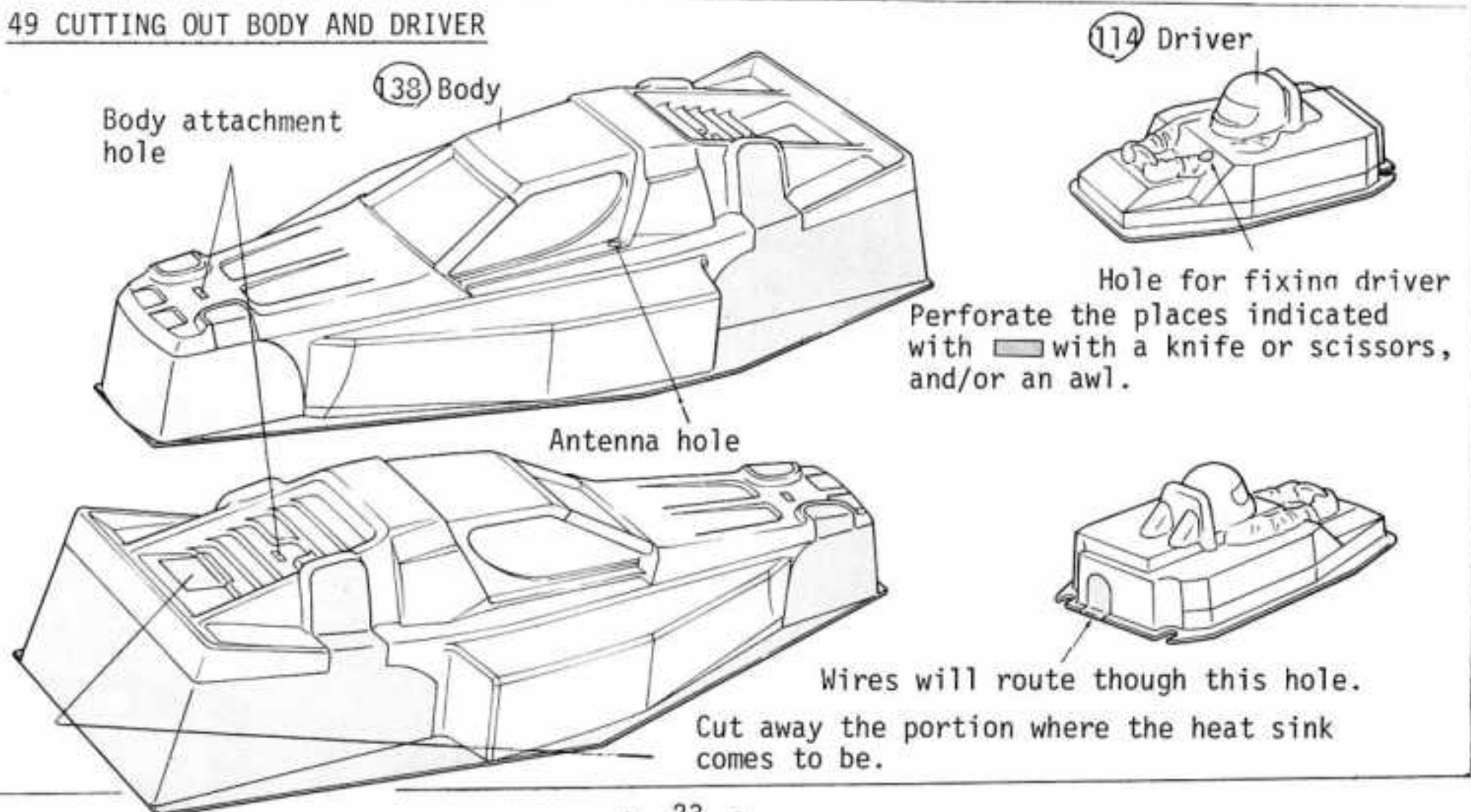

50 FINISHING OF BODY

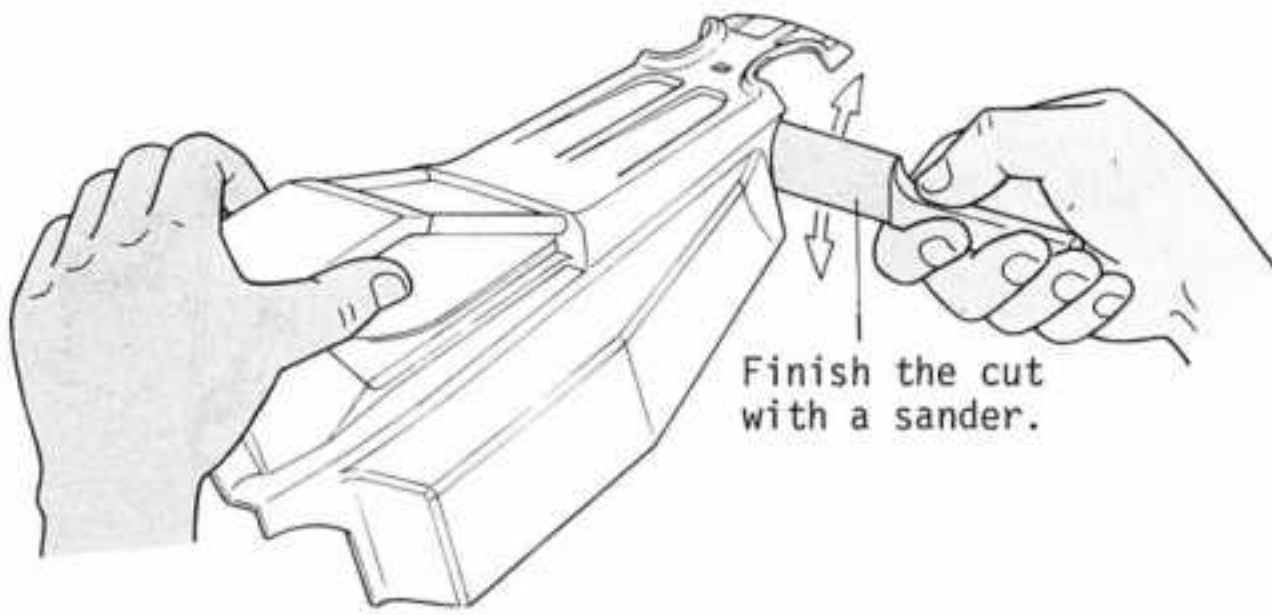

The "Round Cutter/Sander" is available at Kyosho which is composed of snips for the exclusive use of cutting the polycarbonate body and a sander.

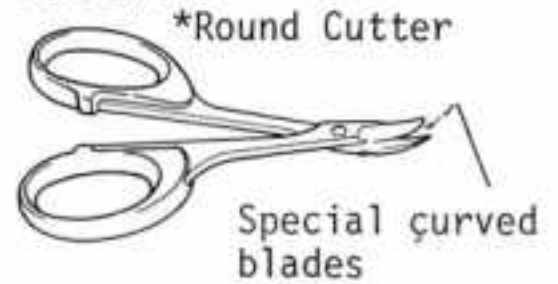

51 PAINTING

First, wash the body to remove any oil or dirt. Rinse thoroughly. Paint the inside of the body. You can obtain a color scheme by masking a portion with tape then removing the tape and painting. Apply the lightest color last.

Mask the windows with something like Micron Line Tape and paint it any color at your choice.

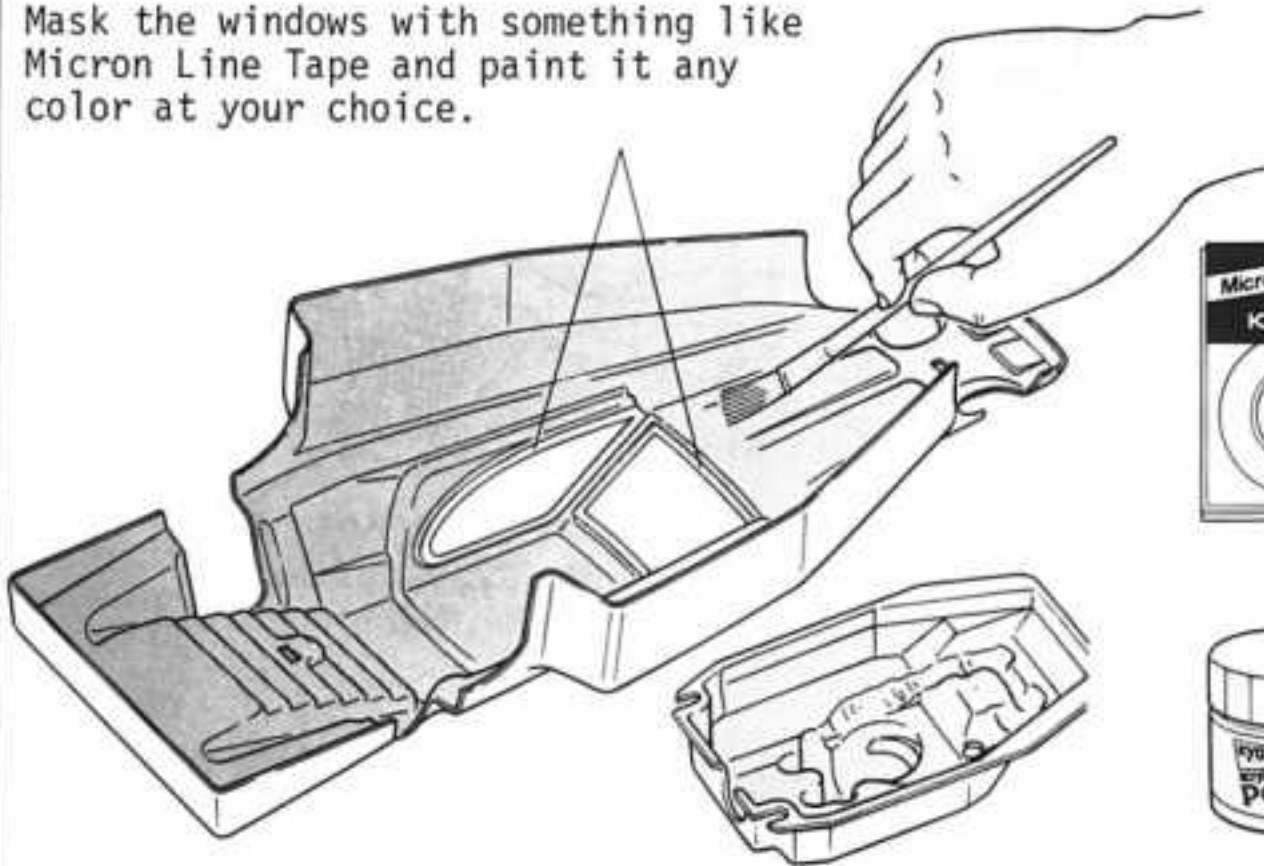

Micro-Line tape enhances the appearance of any model.



Polyca Color Paint is available for painting your Lexan Bodies. 12 great looking colors!

52 MOUNTING OF DRIVER

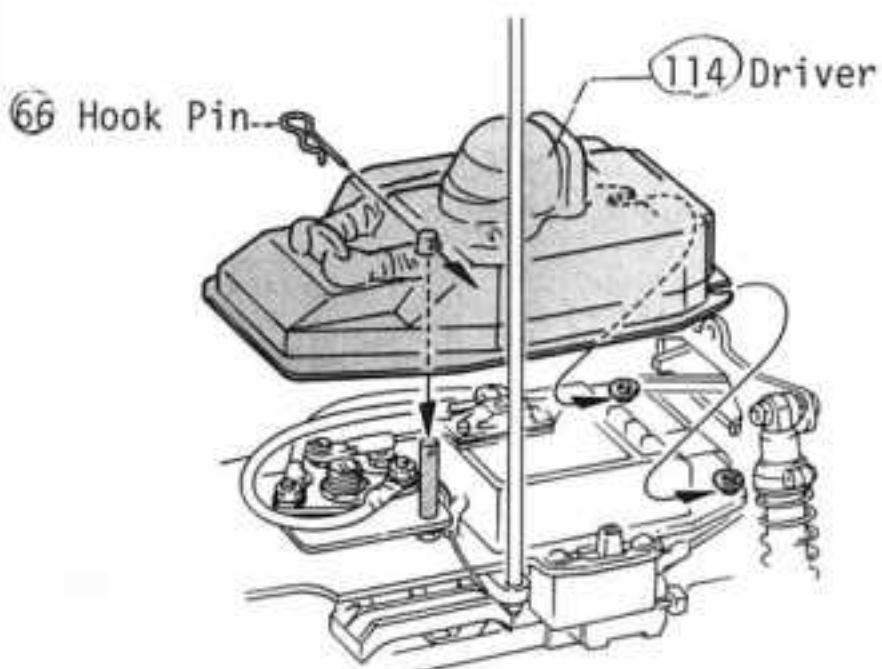

Bundle wires with a strap (S) and cut off excess.

Since the speed controller must move freely, leave slack in the cords.

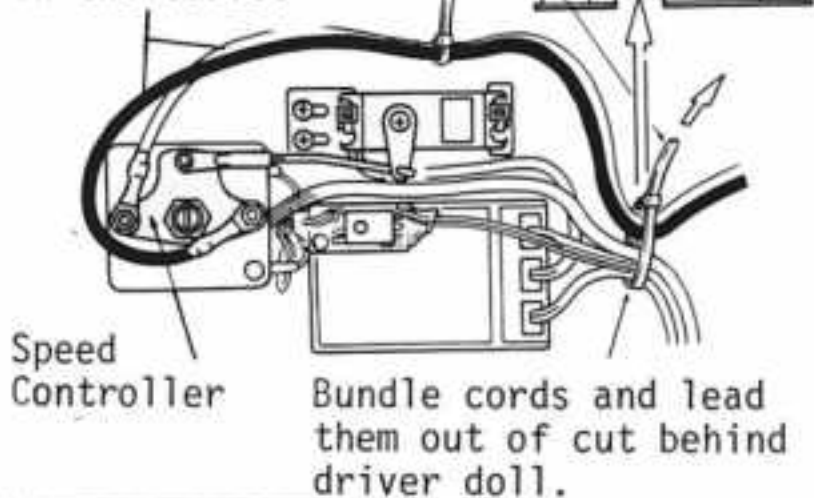

[Working Test of Speed Controller]

1. Confirm that the speed controller wiper is positioned in neutral (refer to the illustration in step 40) and plug in the battery connector (refer to step 53).
2. Switch on the radio control units and operate the speed controller to see if the wiper will move from the lowest to the high and to the reverse as illustrated in step 40.

*When the wiper does not swing smoothly, see if the motor lead is too tight, or, on the other hand, too long and rubs against the inside of the driver doll. Either case will hamper the smooth movement.

53 MOUNTING OF BODY

[Mounting of Ni-Cad Battery]

Hold Ni-cad battery firmly with a Ni-cad battery holder by Ni-Cad Strap.

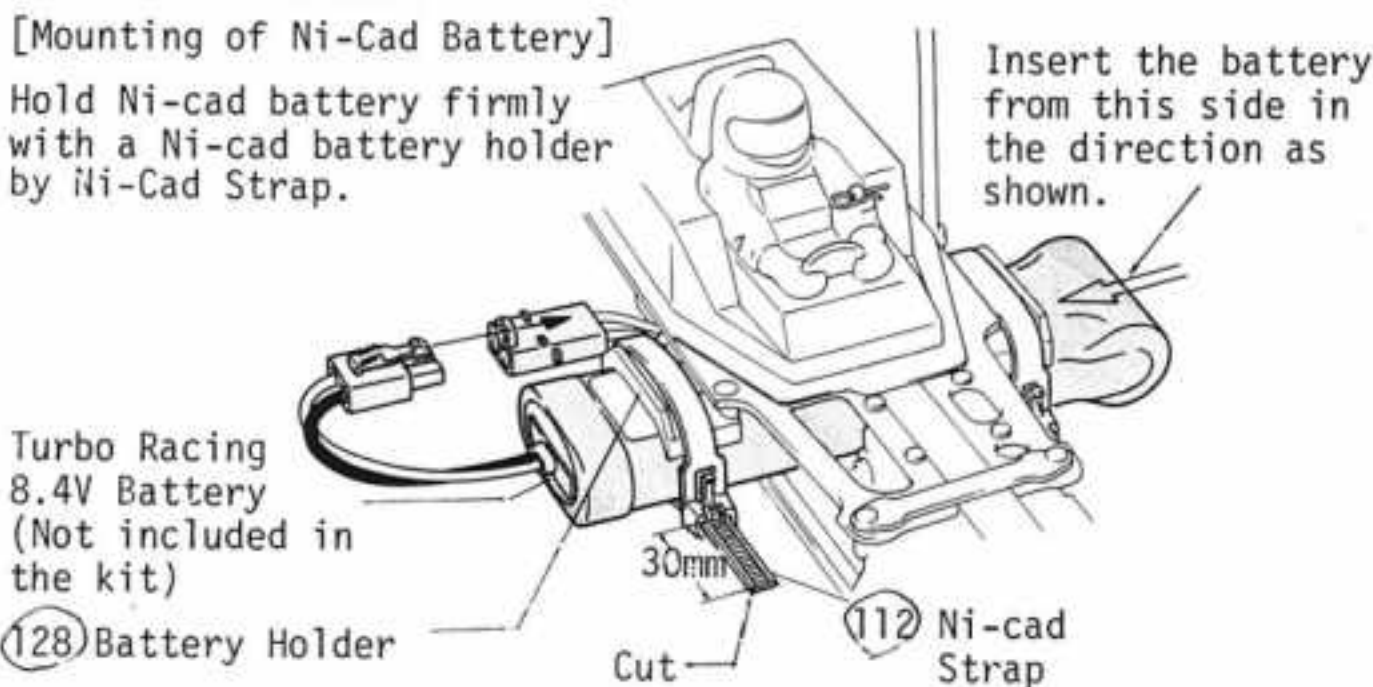

Kyosho puts in the market a high power 8.4V Turbo Racing Battery which is composed of tabless type cells. It can discharge a lot of current at a time to give a model car excellent pick-up power and running ability.

BE SURE TO DISMOUNT THE NI-CAD BATTERY WHEN YOU WILL NOT RUN THE CAR OR KEEP IT IN STOCK.

[Affixing of Decals]

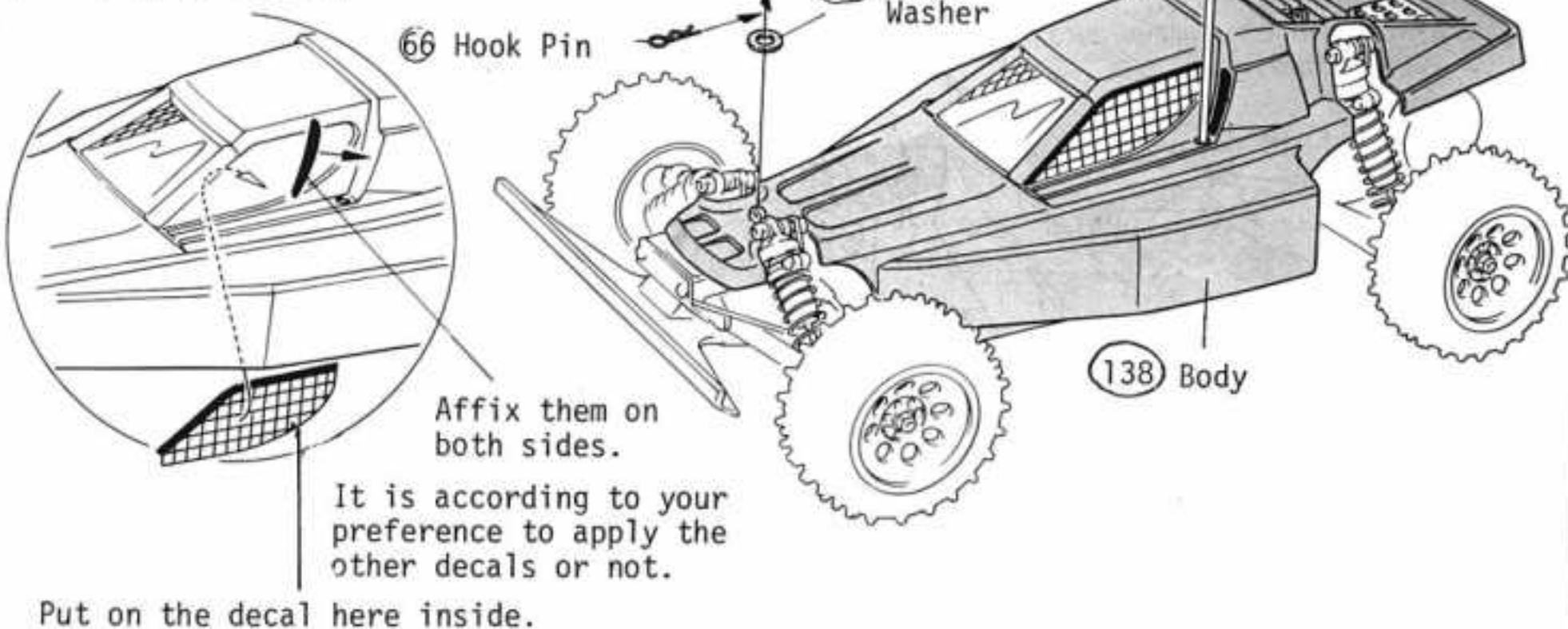

Affix them on both sides.

It is according to your preference to apply the other decals or not.

Put on the decal here inside.

ADJUSTING THE CHAIN

To avoid any damage to sprockets, adjust the chain every 5-6 runs.

1. Remove the Chain Cover

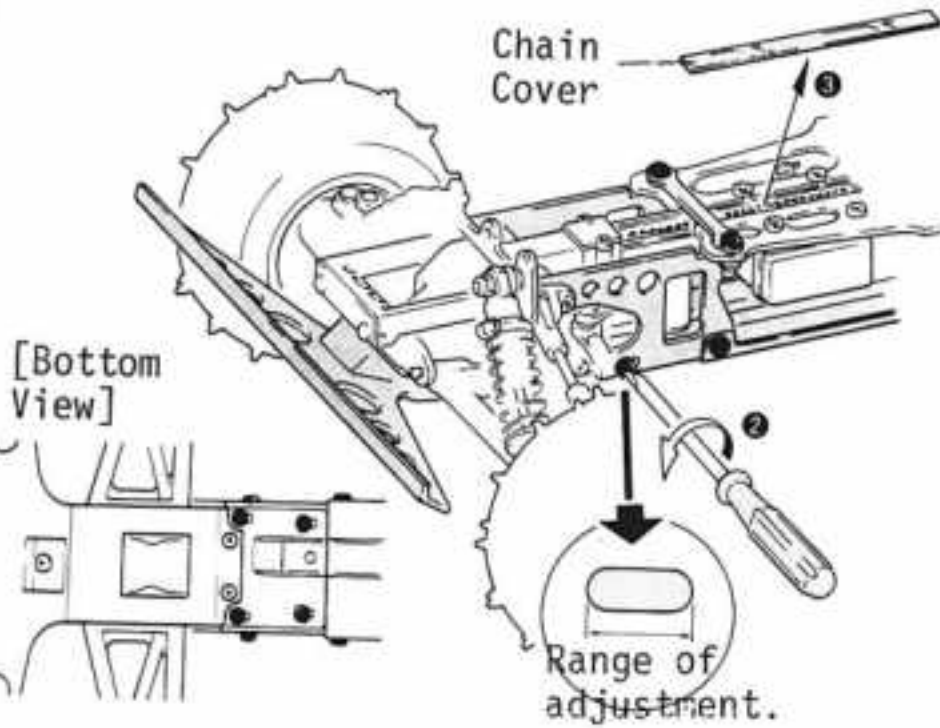

- ① Remove the Body.
- ② Loosen 10 (darkened) screws 1/2 turn each.
- ③ Remove the chain cover.

2. Adjust the Chain 1.5mm Allen Wrench

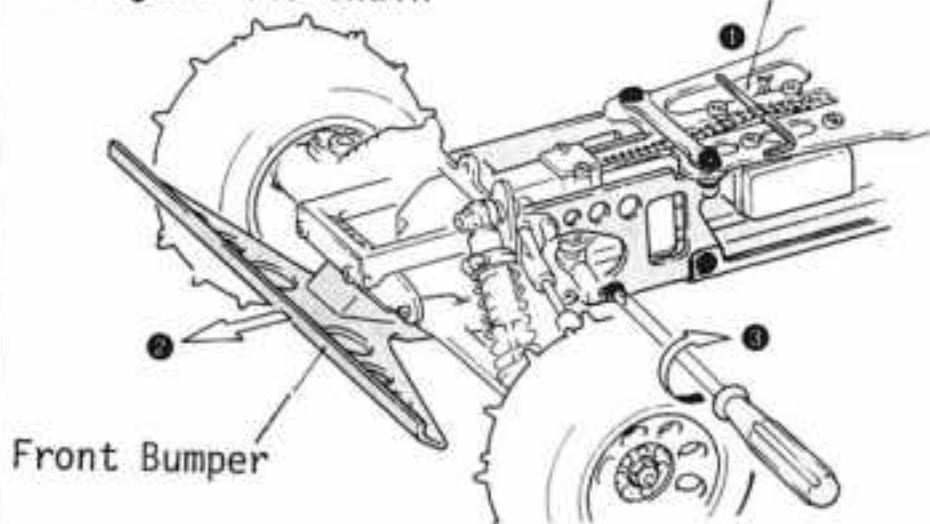

- ① Insert a 1.5mm allen wrench under chain as shown.
- ② Pull bumper forward.
- ③ Keep tension on bumper and tighten the 10 screws firmly.

*When chain is stretched beyond range of adjustment.

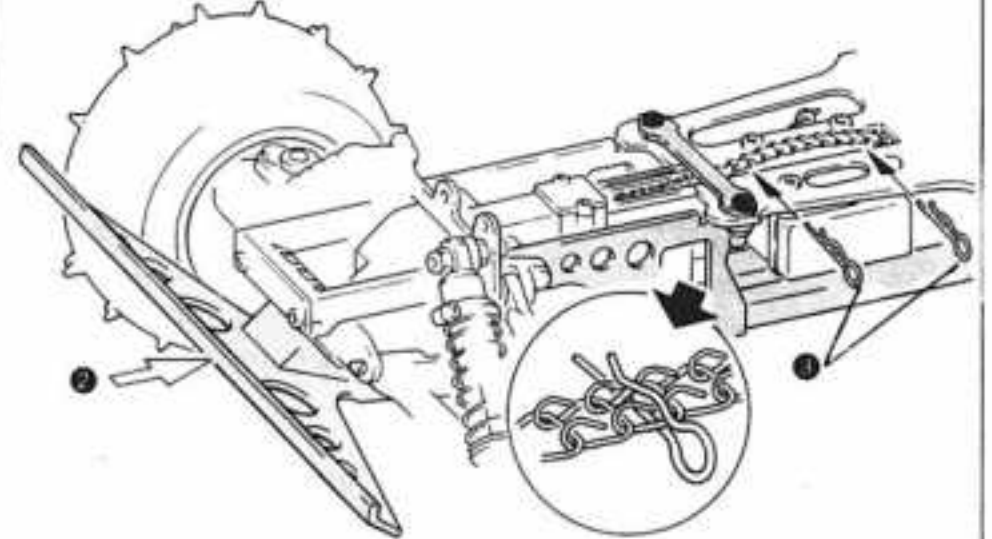

- ① Loosen the 10 screws.
- ② Push bumper rearward to loosen chain fully.
- ③ Hold the chain with hook pins as shown in inset drawing.

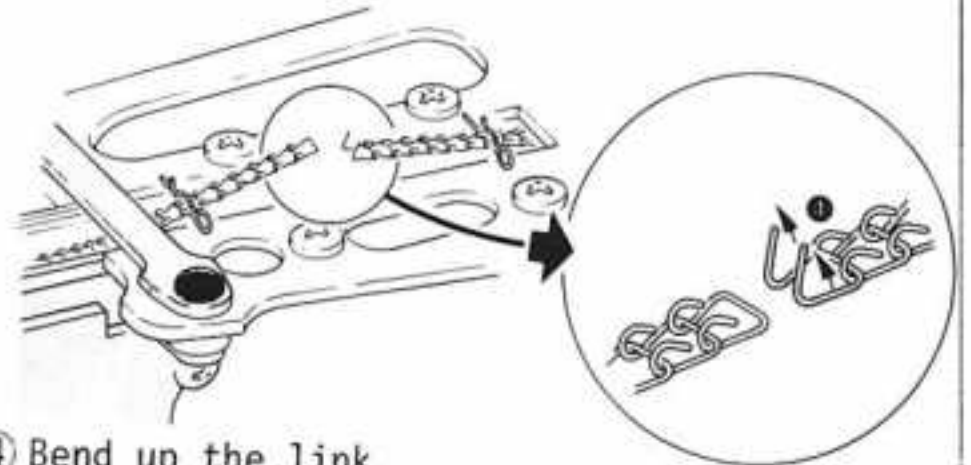

- ④ Bend up the link.

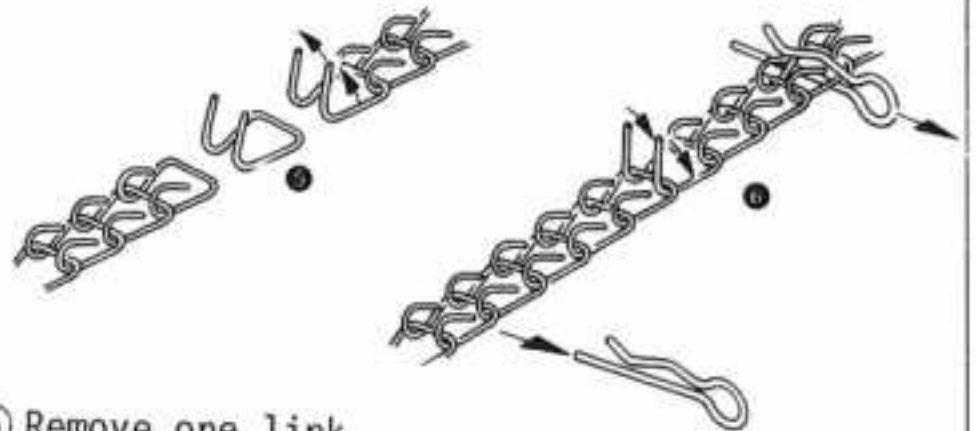

- ⑤ Remove one link.
- ⑥ Connect the chain again by bending the link ends down. Readjust the chain.

CHECK THE LIMITER

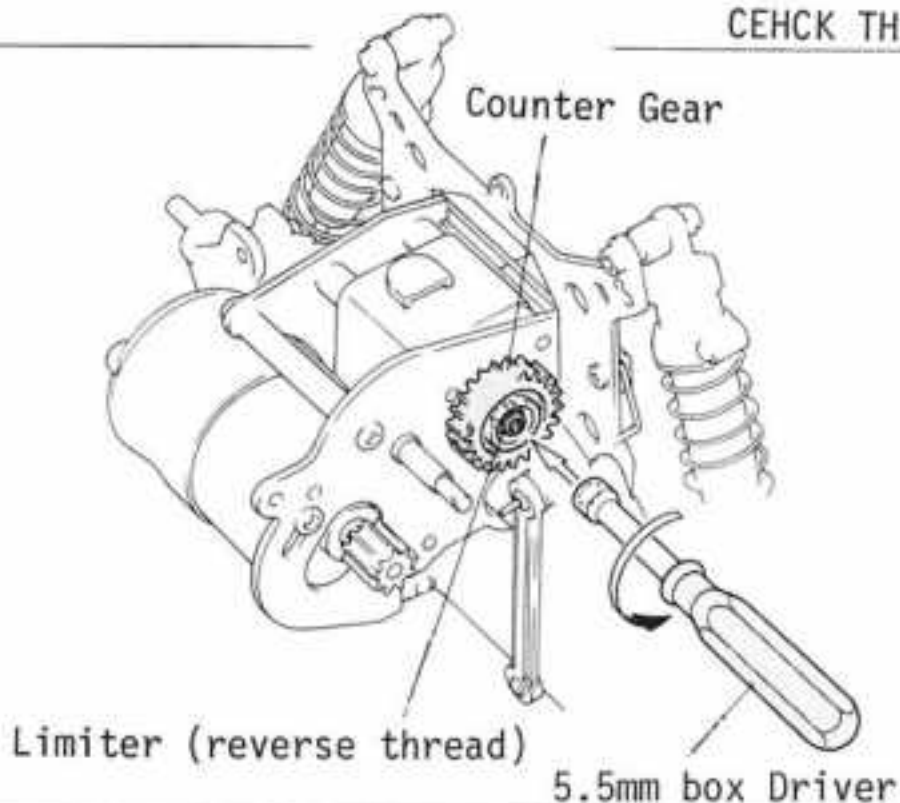

Check the limiter nut once in a while. Whenever you find it loosen, tighten it firmly; otherwise, the counter gear will run idle excessively to result in melting the nut.

ADJUSTMENT OF SHOCK SIZE

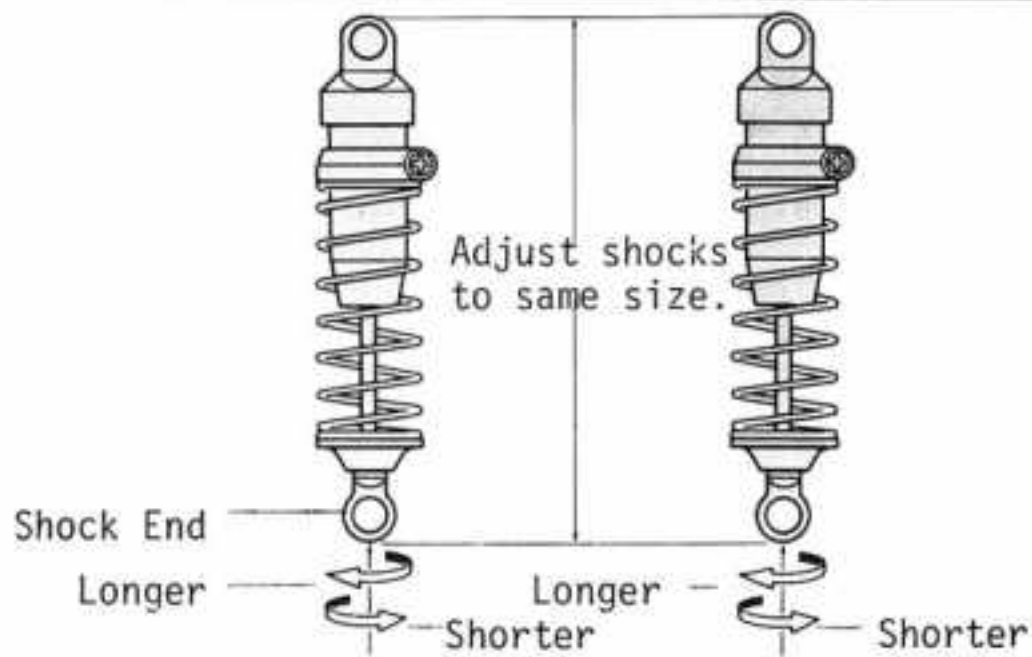

Adjust the shocks so that both front shocks and both rear shocks are exactly the same length.

BASIC ADJUSTMENT GUIDE FOR THE OPTIMA

[Front Camber Adjustment]

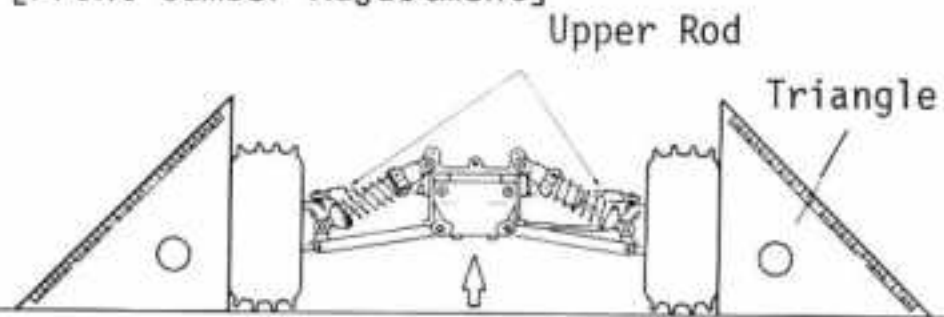

Place the car on a flat surface with the chassis raised as high as possible and adjust the length of the front and rear upper rods in a way so that the tires stand at a right angle to the ground.

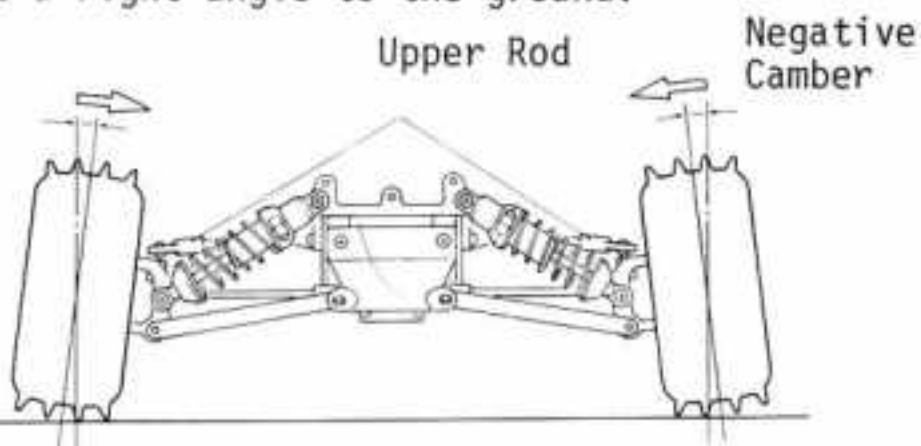

Negative camber results when you make the upper rods shorter.

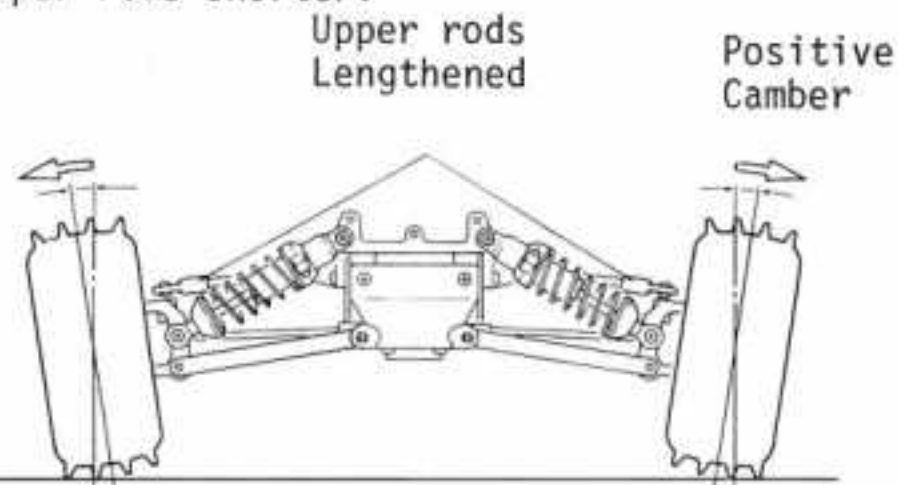

Positive camber results when you make the upper rods longer.

[Front Wheel Height]

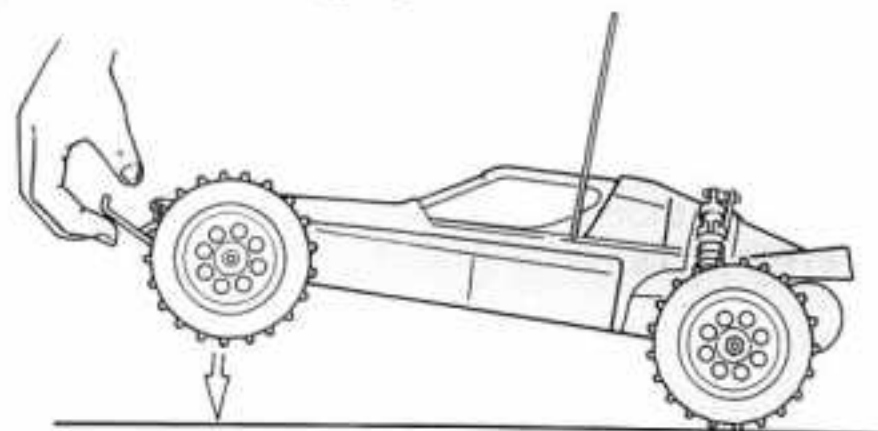

Place the car on a flat area, raise the front end and then lower the front wheels slowly to see whether they will touch the ground evenly. If not, adjust the length of the shocks. If they are uneven, steering to the right and left will not be the same.

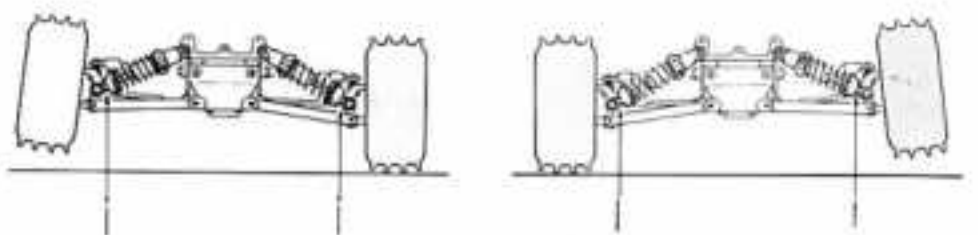

Lengthen Shorten Shorten Lengthen

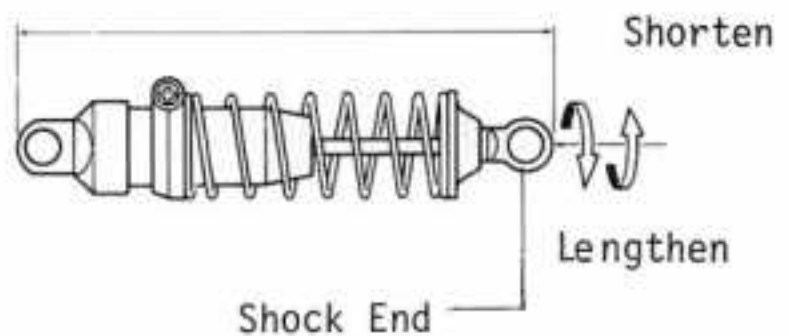

Adjust the length by turning the shock end.

[Rear Camber Adjustment]

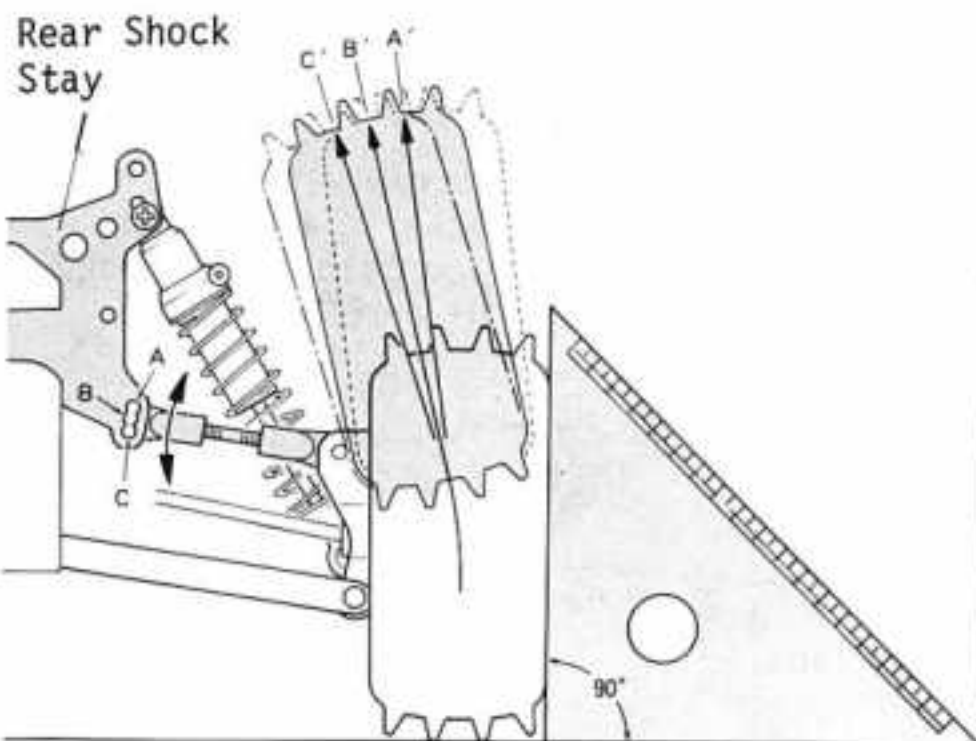

You can alter the rear wheel camber by shifting the bolt hole location of the upper rod. Hole "A" provides more positive camber while hole "C" provides more negative camber. The middle hole "B" should be used normally.

[Customizing the Tires]

You can increase performance for various track conditions by trimming the knobs of the tires. Consult the chart below.

Trim the knobs.

Track	Amount of Trim
Grass	1/2
Concrete	2/3
Sand	None
Hard Dirt	1/3
Soft Dirt	None

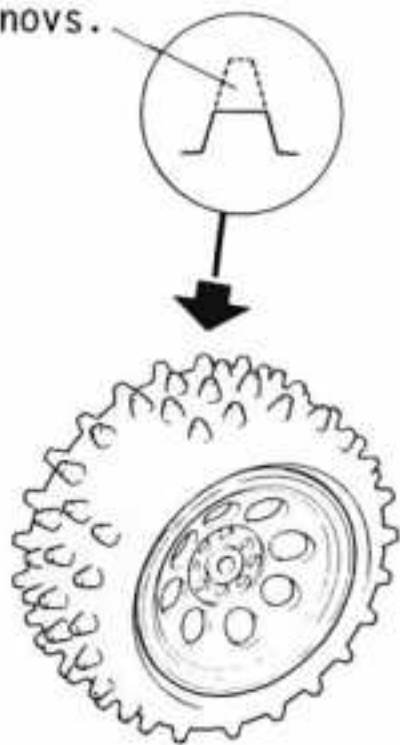

[Optional Tires]

The "Option House" set, available separately, offers you the W5031 Low-Profile Tires for hard ground, and the W5032 for soft soil.

Pinion Gear	9T	10T	11T	12T	13T	14T
Gear Ratio	13.8	12.4	11.2	10.3	9.85	8.8
Motor	240S			360 Gold		
	240SB					

[Adjusting Front/Rear Power Ratio]

By changing the front and rear sprockets, you can change the power ratio.

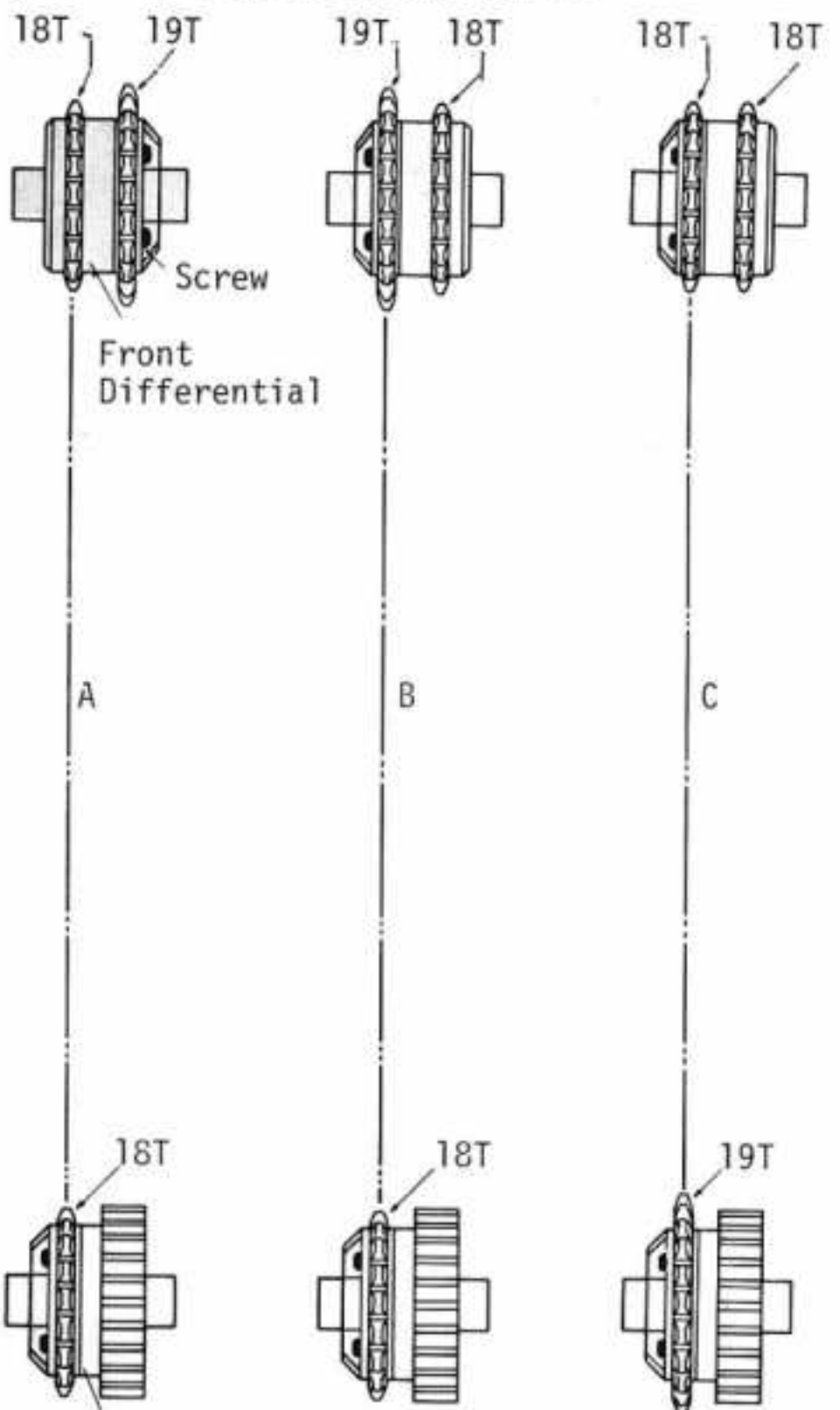

Rear Differential

- A. Normal: Front and rear turn at same rate.
- B. Rear wheels have slightly more power.
- C. Front wheels have slightly more power.

[Keeping the Chain Clean]

Be careful not to let sand and dust in through the chain cover and chain guide. Seal the openings around the chain cover and guide with cellophane tape or silicone sealer. Remove the gearbox hatch cover and hold the car upside down to remove any dirt.

[Replacing the Chain]

To replace the chain, remove the chain cover (B); and holding the model vertically with the front upward, feed the chain from the front sprocket to the rear. It may require a few tries to get it right.

HOW TO USE 8.4V BATTERY

The 8.4V Turbo Racing Battery is a high power battery pack for more powerful running. It puts out about 1.4 times the power of the existing 7.2V racing battery. With higher voltage, it will discharge a greater amount of current. So you have to be careful if there is any loose contact or connection in the circuit. Plug out the connector when you store the car after a run.



CHARGE THE 8.4V BATTERY

When you charge it from a 100V source, the 8.4V AC Quick Charger is ideal. You can charge it in 50 minutes. From a 12V battery, The Multi-Charger or the Auto Charger (auto cut off) are recommended, the former will charge it in 25 minutes at the highest range. It will often happen that, toward the end of charging, the charging amperage is tend to decline. This is a natural course of events because of a little disparity in voltage between the two batteries.

Multi-Charger



Auto Charger

HOW TO USE MOTOR

The Le Mans 240S is designed as a high-rotation and high-power motor, still there are some requirements to bring out its maximum capability;

1. The portion of commutator and brushes is a possible place to generate heat. So check the point each time if you impose heavy load on it. If you find it discolored or any carbon accumulated, run it idle for 10 to 15 minutes after removing the pinion gear.
2. Perforate the motor cover as shown in step 28 on page 12 without fail for better ventilation. Without it, the motor may be damaged.
3. Adjust the timing point according to the duration of a run within the range between 0 to 6. The more number of timing adjustment, the more speed, at the same time, the more consumption of current and the shorter duration of running.

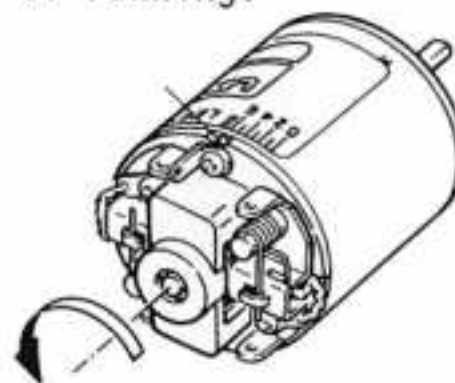

4. Overhaul the motor periodically. (Refer to the instruction which came with the motor)

RUNNING THE OPTIMA

The same battery powers the radio and motor. As soon as the car starts to slow down, recharge the battery. Otherwise you will quickly lose control.

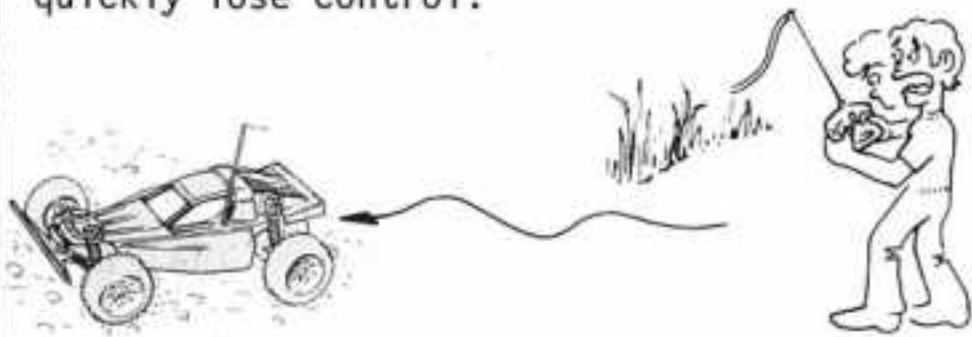

After running, always remove the battery from the car.



[Check Before Every Run]

1. Check to see if all bolts and nuts are tightened firmly.
2. Check to see Ni-cad battery is fully charged.
3. Check to see if the steering and speed control is in proportion to your control of the transmitter.
4. Check to see that all wiring is properly insulated.
5. Check to see if parts are moving smoothly.

[Operating Procedures]

1. Turn transmitter switch on.
2. Switch on the receiver.
3. Check to see if the radio system is working properly.

NOTE: When turning off the switches, turn off the receiver first then transmitter. Otherwise, the servos may be left in a position other than neutral.

[TROUBLE SHOOTING IF THE CAR DOES NOT START]

1. Poor contact of connectors of batteries, connector, and speed control
2. Check to see if the Ni-cad battery is fully charged.
3. Check to see shortage of battery power for the transmitter.
4. Signal jamming from other radios.

WARNING FOR RUNNING THE CAR

The electric R/C powered by a highly efficient Ni-cad battery runs unexpectedly fast. So great care is required when you handle the car and the battery.

- *Do not run the car in the crowd and on the road.
- *Check the frequency bands when you see someone else also trying to run his car at a time with you. Radio control systems on the same frequency will respond each other and causing them to go out of control.
- *If your car suddenly stalled, or being caught by some obstacles, do not try to move the car further. It may result in burning the motor or wiring or in damage on other parts.
- *Do not try to hold the rotating wheels forcibly.
- *When connecting the Ni-cad battery, be sure that the speed controller is positioned in neutral.
- *Any binding or drag on the bearing portion of driving system imposes heavy load to the motor and battery, thus causing overheating of the components or that the car does not gain speed. So check to see always if the driving system will turn smoothly. Application of oil and grease is also very important.
- *With those cars which have only one battery powering both the motor and the radio control units, the cars come to be out of control as the battery voltage is being dropped down. So whenever you will find your car losing speed, discontinue the operation.

MAINTENANCE AFTER A RUNNING

- *After a run of the radio controlled car, remove the Ni-cad battery from the car and store it separately.
- *When you have finished running the car, clean dirt off the car.
- *Turn off the switches of the radio control units without fail.
- *Apply grease on the moving parts regularly.
- *Check that all screws and nuts are tightened properly.

HANDLING THE MOTOR

- *The motor becomes hot after each run. So continuous running may shorten its life. Do not run the car until the motor gets cool after each operation.
- *After several runs the motor may lose its power. This is because of carbon accumulated on the commutator of motor. In such a case, remove the pinion gear and run it idly for 15 minutes under 7.2 volts.
- *Oil the bearings of motor periodically.

EXPLODED VIEW OF FRONT AND REAR DIFFERENTIAL

[Front Differential]

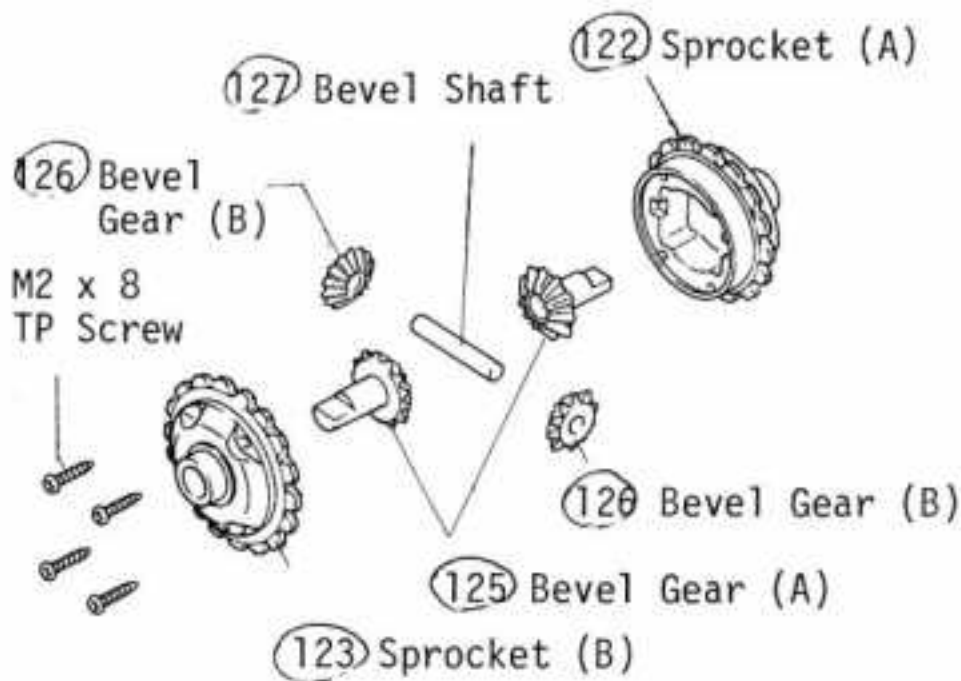

[Rear Differential]

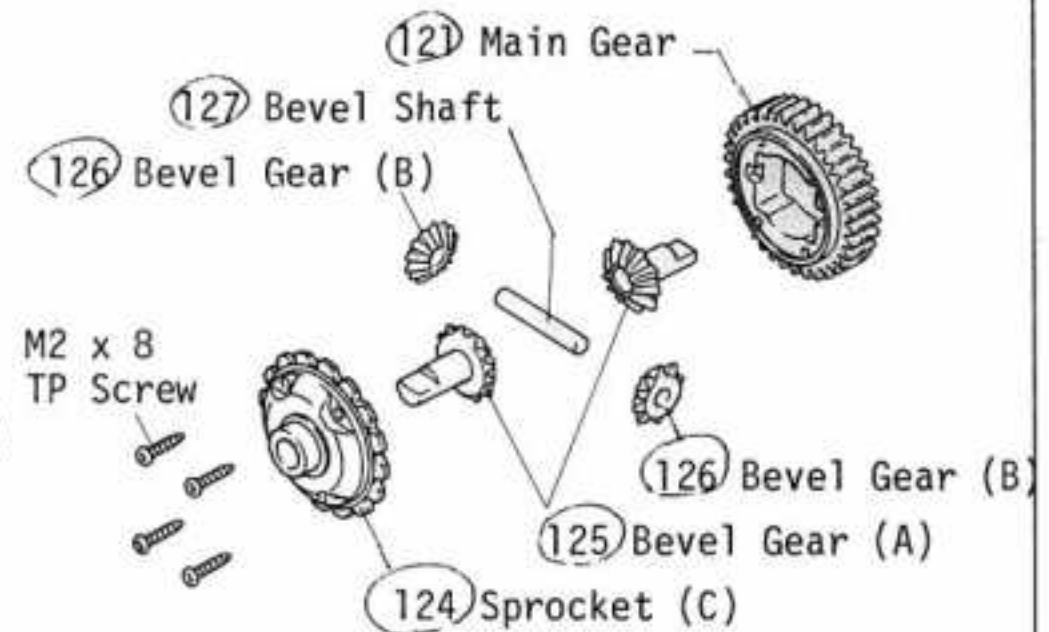

KEY NUMBERS FOR PARTS

No.	Parts Name	Q'ty	No.	Parts Name	Q'ty	No.	Parts Name	Q'ty
①	Tire	4	⑤7	Rear Hub (R)	1	⑩8	Resistor	1set
②	Wheel (1)	4	⑤8	Sus. Shaft (C) (Black Color)	2	⑩9	Front Bumper	1
③	" (2)	4	⑤9	Rear Sus. Arm	2	⑪0	Drive Washer	4
④	" (3)	4	⑥0	Sus. Shaft (D)	2	⑪1	Strap (S)	9
⑤	8ø x 14 Bearing	4	⑥1	Rear Sus. Strut	1	⑪2	Ni-cad Strap	2
⑥	Joint	4	⑥2	Radio Plate	1	⑪3	Steering Rod	1
⑦	Allen Wrench (2mm)	1	⑥3	4ø x 8 Bearing	2	⑪4	Driver	1
⑧	Stabilizer End Ball (Gold Color)	4	⑥4	Center Gear	1	⑪5	Strap (L)	1
⑨	Gear Box (L)	1	⑥5	O Ring (Black Color)	1	⑪6	Radio Plate Support	1
⑩	Fainal Pinion Gear	1	⑥6	Hook Pin	4	⑪7	Radio Post Screw	2
⑪	Gear box (R)	1	⑥7	Pinion Gear (9Z)	1	⑪8	M2.6 Pivot Ball (Black Color)	4
⑫	Center Gear Shaft	1	⑥8	Bearing Collar (Nylon)	1	⑪9	5ø x 10 Bearing	10
⑬	Rear Plate (R)	1	⑥9	Motor Cover	1	⑫0	Front Stabilizer	1
⑭	" (L)	1	⑦0	Le Mans 240S Motor	1	⑫1	Main Gear	1
⑮	Counter Shaft	1	⑦1	Shock Oil	1	⑫2	Sprocket (A)	1
⑯	M3 Pivot Ball (Silver Color)	8	⑦2	Front Shock Case	2	⑫3	" (B)	1
⑰	Rear Shock Stay	1	⑦3	Rear Shock Case	2	⑫4	" (C)	1
⑱	Gear Box Hatch	1	⑦4	Shock Piston	4	⑫5	Bevel Gear (A)	4
⑲	Front Sus. Plate	1	⑦5	Front Shock Shaft	2	⑫6	" (B)	4
⑳	Under Guard	1	⑦6	Rear Shock Shaft	2	⑫7	Bevel Shaft	2
㉑	Front Support	1	⑦7	Shock O Ring	8	⑫8	Battery Holder	2
㉒	Main Chassis	2	⑦8	Shock Collar (White Color)	4	⑫9	Bulk Head (L)	1
㉓	Front Side Plate	2	⑦9	Plastic Washer (Black color)	4	⑬0	" (R)	1
㉔	Front Upper Pivot (L)	1	⑧0	Spring Holder	4	⑬1	5ø Shim	4
㉕	" (R)	1	⑧1	Shock End	4	⑬2	Body Washer	2
㉖	Radio Post (R)	2	⑧2	Spring Stopper	4	⑬3	Decal	1
㉗	" (F)	2	⑧3	Diaphragm	4	⑬4	Regulator	1
㉘	Chain Guide (B)	1	⑧4	C Ring	4	⑬5	Connector	1
㉙	" (C)	1	⑧5	Joint Collar	2	⑬6	Silicon Grease	1
⑳0	Chain	1	⑧6	Gear Cover	1	⑬7	Rear Stabilizer	1
㉑1	Ball Nut	4	⑧7	Gear Cover Seal	1	⑬8	Body	1
㉑2	Saver Shaft (A)	1	⑧8	Servo Spacer (A)	1	⑬9	Rear Hub (L)	1
㉑3	" (B)	1	⑧9	" (B)	1	⑭0	Motor Cord	1set
㉑4	Servo Saver (A)	1set	⑨0	Servo Mount	1	⑭1	Front Spring	2
㉑5	" (B)	1	⑨1	Speed Control Spring	1	⑭2	Rear Spring	2
㉑6	M2 Shaft	1	⑨2	Speed Control Nut	1	⑭3	Chassis Guard	1
㉑7	Ball End (S)	4	⑨3	Speed Control Contact Point	2	⑭4	Heat Sink (A)	1
㉑8	King Pin	4	⑨4	Speed Control Stud	1	⑭5	" (B)	1
㉑9	Knuckle Arm 1 (L)	1	⑨5	Speed Control Pivot	1	⑭6	Motor Cleaner	1
㉒0	" 2 (R)	1	⑨6	Speed Control PC Board	1	⑭7	Stabilizer Stopper	2
㉒1	Front Shaft	2	⑨7	Speed Control Horn	1	⑭8	Stabilizer Link (L)	2
㉒2	Front Hub (L)	1	⑨8	Driver Post	1	⑭9	" (S)	2
㉒3	" (R)	1	⑨9	Chain Cover (A)	1	⑮0	Stabilizer Ball	4
㉒4	E Ring (E-2.5)	12	⑩0	Chain Guide (A)	1	⑮1	Counter Gear	1
㉒5	Sus. Shaft (A) (Silver Color)	2	⑩1	" (D)	1	⑮2	Limit Spring	1
㉒6	" (B)	2	⑩2	Chain Cover (B)	1	⑮3	Motor Plate	1
㉒7	" ()	2	⑩3	Front Strut Plate	1	⑮4	Shock Fixing Collar (Red Plastic)	4
㉒8	Allen Wrench(1.5mm)	1	⑩4	Servo Rod	1	⑮5	Shock Cap	4
㉒9	Front Sus. Arm	2	⑩5	Saver Spacer	1	⑮6	Washer(A) 3øx10 (Black Color)	1
㉓0	5.8ø Ball	4	⑩6	Double Sided Tape	1	⑮7	Wahser(B) 7øx11 (Gold Color)	1
㉓1	Ball End (L)	12	⑩7	Antenna Pipe	1	⑮8	M3 Nylon Nut (Gold Color)	1
㉓2	Upper Rod	4				⑮9	Allen Wrench(2.5mm)	1
㉓3	Front Shock Stay	1						
㉓4	Swing Shaft	4						
㉓5	Shock Bush	4						
㉓6	Tie Rod	2						
㉓7	Rear Shaft	2						

PURCHASING PARTS FOR YOUR KIT

You can purchase replacement and optional parts for your kit. All of the part identified by key numbers (see page for a complete list) are usually not available singularly, but we offer these parts in convenient parts "packs" which can be purchased separately. To figure out which parts pack you need, find the key number for that part within the manual. Then consult our parts pack guide, below. When referring to the parts you need, always use the Parts Pack Number. For instance, if you need a Center Gear Shaft (Key #12) ask your dealer for Kyosho Parts Pack OT-7 (Rear Plate Set).

Parts Pack #	Description	Includes These Key Numbers
OT- 1	Gear Box	9 11 129 130 x 1
OT- 2	Chain	30 x 1
OT- 4	King Pin	38 x 4
OT- 5	Joint	6 x 2
OT- 6	Swing Shaft	53 x 2
OT- 7	Rear Plate Set	12 13 14 x 1 85 x 2
OT- 8	Front Side Plate	23 x 2
OT-11	Suspension Shaft	45 46 58 60 x 2
OT-12	Radio Plate	62 x 1
OT-14	Under Guard	20 x 1
OT-15	Front Bumper	109 x 1
OT-16	Knuckle Arm	39 40 x 1
OT-17	Front Shaft	41 x 2
OT-18	Rear Shaft	56 x 2
OT-19	Drive Washer	110 x 4
OT-20	Main Chassis	22 x 2
OT-21	Screw Set	Screw, Nut, Wrench Set
OT-22	Body Washer	132 x 10
OT-26	Driver	98 114 x 1
OT-27	Sprocket, Gear Set	64 121 122 123 124 x 1
OT-28	Differential Gear Set	127 x 2 125 126 x 1
OT-29	O Ring	65 x 10
OT-31	M3 Pillow Ball (Pivot Ball)	16 x 10
OT-32	5.8ø Ball	49 x 10
OT-33	Ball Nut (M2.6)	31 x 10
OT-34	Plate Set	19 61 88 89 103 105 x 1
OT-35	Upper Rod Set	86 x 1 104 x 2 37 51 x 4 60 x 8
OT-36	M2.6 Pivot Ball	118 x 10
OT-37	Cord Set	140 x 1
OT-38	Silicon Gress (2pcs.)	136 x 2
OT-39	E Ring (2.5)	44 x 10
OT-41	Final Pinion Gear	10 x 1
OT-42	Servo Saver Set	32 33 35 x 1 34 x 1set
OT-45	Rear Hub	57 139 x 1
OT-46	Chain Guide Set	28 99 100 102 x 1
OT-48	Battery Holder Set	18 29 101 x 1 26 27 128 x 2
OT-49	Gear Cover Set	21 86 87 90 116 x 1
OT-54	Stabilizer Set	120 137 x 1 147 148 149 x 2 8 150 x 4
OT-55	Front Hub Set	24 25 42 43 x 1
OT-57	Special Shock Stay	17 52 x 1
OT-66	Low Profile Tire(Pin Type)	1 x 2
OT-67	Wheel(For Low Profile Tire)	2 3 4 x 2
OT-68	Decal (Turbo Optima)	133 x 1
OT-69	Suspension Arm Set (Hardened)	48 59 x 2
OT-70	Body (Turbo Optima)	138 x 1
OT-71	Chassis Guard	143 x 1
OT-72	Heat Sink for Resistor	144 145 x 1
OT-73	Motor Cleaner Set	146 x 2 153 x 1
OT-74	Limiter Gear Set	15 151 152 156 157 x 1 158 x 2
OT-75	Connector (for 8.4V)	135 x 1

<u>Parts Pack #</u>	<u>Description</u>	<u>Includes These Key Numbers</u>
SC-40	Motor Cover	69 x 1
SC-46	Double Sided Tape	106 x 1
SC-67	Speed Control Set	91 92 94 95 96 97 x 1 93 x 2
SC-78	Speed Control PC Board	96 x 1
SC-79	Speed Control Contact Point	93 x 2
SC-89	Tierod	55 x 2 50 118 x 4
SC-101	Rear Shaft Shim	131 x 10
SC-105	Resistor	108 x 1
EF-37	Strap (S)	111 x 6
EF-38	" (M)	115 x 6
EF-39	Ni-Cad Strap	112 x 6
EP-22	Hook Pin	66 x 5
LD-76	Shock Bush	54 x 10
SD-79	Antenna Pipe	107 x 5
1911	8ø x 14 Bearing	5 x 2
1901	Ball Bearing 5ø x 10	119 x 2
1903	" 4ø x 8	68 x 1 63 x 2
W-5001	Pressure Oil Shock (S), Front	72 74 75 78 79 80 81 82 83 84 141 154 x 2
W-5002	" " " (L), Rear	73 74 76 78 80 81 82 83 84 142 154 x 2
W-5009	Hard Pinion Gear 9T	67 x 1
1990	Regulator	134 x 1 (for 7.2V . 8.4V)
1971	Bearing Set	63 x 2 119 x 10 5 x 4

OPTIONAL PARTS

OT-64	Speical Wing (Silvered)	Polycaborante
OT-65	Wing Stay Set	For attachment of OT64
OT-76	Hard Final Pinion Gear	Hardened Alumite
W-0101	Motor Guard	Case of Protecting your motor.
W-5031	Low Profile Tire Allround Type	For Hard Truck
W-5032	Low Profile Tire, High Grip "	For Soft Truck
W-5010	Hard Pinion Gear 10T	Gear Ratio (12.4 : 1)
W-5011	Hard Pinion Gear 11T	Gear Ratio (11.2 : 1)
1951	Shock Oil Set (S.M.H)	3 Different Weights
OT-23	Pinion Gear 12T	Gear Ratio (10.3 : 1)
OT-50	" 13T	" (9.5 : 1)
OT-51	" 14T	" (8.8 : 1)
OT-56	Light Weight Aluminum TP Screw Set	Tapping (Aluminum), Nylon Nut Set
SC-80	Speed Control(4 speed Registor)	4 Forward Speeds
LM-15	Cooling Plate	For Le Mans Motor
OT-47	Front Hub Set	For better steering
W-5021	Low Profile Wheel	Silvered
1863	Sponser Sticker	
W-0102	Side Guard	For Protecting Rear Sus. Arm
1952	Differential Oil	
W-1001	High Corbon Plate 1.7	For Material of Mecha Plate
W-0103	Gold Plate Set	For Ornament of Your Model

1 INSTALLATION OF JOINT

M4 x 4 Set Screws(4) 

⑤ 8φ x 14 Bearings(4) 

⑥ Joints(4) 

2 ASSEMBLY OF REAR GEAR BOX

M3x18 TP Screws (3) 

M4x4 Set Screw (1) 

①①⑨ 5φ x 10 Bearing (1) 

3 INSTALLATION OF GEAR BASE

M3 x 8 Screws (3) 

M3 x 45 Bind Screws (4) 

⑫ Center Gear Shaft (1) 

M3 Spring Washers (4) 

4 INSTALLATION OF FINAL PINION

3φ Washer (1) 

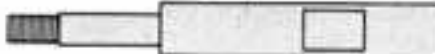
⑮ Counter Shaft (1) 

⑮② Limiter Spring(1) 

⑮⑥ Washer (A) (1) (3φ x 10 Black Color) 

⑮⑦ Washer (B) (1) (7φ x 11 Black Color) 



⑮⑧ M3 Nylon Nut (1) (Gold Color) 

⑮⑨ 5φ x 10 Bearing(1) 

5 INSTALLATION OF REAR SHOCK STAY

M3 x 12 TP Screws(2) 

M3 x 18 Cap Bolts (2) 

M3 Nuts (6) 
⑮⑩ M3 Pivot Balls(2) (Silver Color) 

⑮⑧ Gear Box Hatch (Plastic) (1) 

6 INSTALLATION OF FRONT GEAR BOX

M3 x 12 TP Screws (3) 

M3 x 18 TP Screw (1) 

7 INSTALLATION OF LOWER GUARD

M3 x 8 TP Screws (2) 

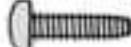
M3 x 10 TP Screws (4) 

8 INSTALLATION OF REAR PLATE

M3 x 8 Screws (4) 

M3 x 8 TP Screws (2) 

⑮⑥ Rear Radio Posts (Bigger)(Plastic) (2) 

9 INSTALLATION OF BULKHEAD

M2.6 x 6 Bind Screws(2) 

10 INSTALLATION OF FRONT SUPPORT

M2.6 x 6 Bind Screws (4) 

M3 x 8 TP Screws (2) 

M3 x 12 TP Screws(2) 

M3 x 16 TP Screws(2) 

⑮④ Front Upper Pivot (L) (Plastic) (1) 

⑮⑤ Front Upper Pivot (R) (Plastic) (1) 

⑮⑦ Front Radio Posts(2) (Smaller)(Plastic) 

11 INSTALLATION OF CHAIN GUIDE

M2 x 8 TP Screws (2) 

⑮⑨ Chain Guide (C)(1) (Plastic) 

12 INSTALLATION OF JOING COLLAR

M3 x 8 Screws (2) 

⑮⑤ Joint Collar (1) 

13 ASSEMBLY OF SERVO SAVER

M2.6 x 6 Bind Screw(1) 

M2.6 Washers (2) (Black Color) 

⑮① Ball Nuts (3) 

⑮⑧ M2.6 Pivot Balls (Black Color)(2) 

14 INSTALLATION OF SERVO SAVER

M2.6 x 15 Bind Screws (2) 

⑮② Saver Shaft (A) (1) 

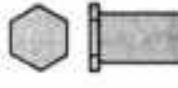
⑮③ Saver Shaft (B) (1) 

⑮⑥ M2 Shaft (1) 

⑮⑦ Ball Ends (S) (2) 

⑮⑤ Saver Spacer(1) 

15 ASSEMBLY OF KNUCKLE ARM

M2.6 Nuts (2) 

⑮⑥ M3 Pivot Balls (Silver Color) (4) 

⑮⑧ King Pins (4) 

⑮⑧ M2.6 Pivot Balls(Black Color) (2) 

⑮⑨ 5φ x 10 Bearings (4) 

16 INSTALLATION OF FRONT SUSPENSION ARM

M3 x 4 Set Screws (2) (Silver Color) 

⑮⑧ Stabilizer End Balls (Gold Color) (2) 







⑮④ E Rings(E-2.5)(2) 

⑮⑤ Sus. Shafts (A)(2) (longer , Silver Color) 



⑮⑥ Sus. Shafts (B) (2) (Shorter, Silver Color) 



17 INSTALLATION OF FRONT UPPER

- M3 x 15 Screws (2) 
- M3 x 18 Cap Bolts (2) 
- M3 Nuts (2) 
- M3 Nylon Nuts (2) 
- 49 5.8φ Balls (2) 
- 50 Ball Ends (L) (4) 
- 61 Upper Rods (2) 

18 ASSEMBLY OF SHOCK

- 44 E Rings (E-2.5) (8) 
- 74 Shock Pistons (Red Color) (4) 

This parts are not in use.



Use step [21] and [26]

- 77 Shock O Rings (8) (Red Color) 
- 78 Shock Collars (4) (White Color) 
- 79 Plastic Washers (4) (Black Color) 
- 84 C Rings (4) 
- 81 Shock Ends (4) 



19 FILLING SHOCK WITH OIL

- 83 DIAPHRAGMS (4) 



20 INSTALLATION OF SHOCK SPRING

- 80 Spring Holders (4) 





21 INSTALLATION OF FRONT SHOCK

- M3 Nylon Nuts (2) 
- 64 Shock Bushes (2) (Black Rubber) 
- 154 Shock Fixing Collars (Red Color) (2) 



22 INSTALLATION OF TIE ROD

- 50 Ball Ends (L) (4) 
- 55 Tie Rods (2) 





23 INSTALLATION OF REAR HUB

- 8 Stabilizer End Balls (2) (Gold Color) 
- 16 M3 Pivot Balls (2) (Silver Color) 
- 44 E Rings (E-2.5) (2) 
- 58 Sus. Shafts (C) (2) (Longer, Black Color) 
- 119 5φ x 10 Bearings (4) 

24 INSTALLATION OF REAR SUS. ARM

- M3 x 4 Screws (2) (Silver Color) 
- 60 Shafts (D) (2) (Longer) 





25 INSTALLATION OF REAR UPPER ROD

- M3 x 10 Screws (2) 
- 49 5.8φ Balls (2) 
- 50 Ball Ends (L) (4) 
- 51 Upper Rods (2) 



26 INSTALLATION OF REAR SHOCK

- M3 Nylon Nuts (2) 
- 64 Shock Bushes (2) (Black Rubber) 
- 154 Shock Fixing Collars (2) (Red Color) 

27 INSTALLATION OF CENTER GEAR

- 4φ Washers (2) 
- 63 4 φ x 8 Bearings (2) 
- 65 O Ring (P-3) (1) (Black Rubber) 
- 68 Bearing Collar (1) 



28 INSTALLATION OF MOTOR

- M3 x 3 Set Screw (1) 
- M3 x 8 Screws (2) 



29 INSTALLATION OF GEAR COVER

- 66 Hook Pin (1) 

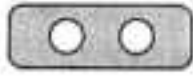

30 INSTALLATION OF MINI SIZE SERVO

- M3 x 6 Flat TP Screws (6) 
- 88 Servo Spacer (A) (1) 
- 89 Servo Spacer (B) (1) 

31 INSTALLATION OF MID-SIZE SERVO

- M3 x 10 TP Screws (2) 
- 89 Servo Spacer (B) (1) 







32 INSTALLATION OF CHAIN GUIDE (A)

- M2x8 TP Screws (2) 
- 100 Chain Guide (D) (1) (Plastic) 







33 MOUNTING RADIO PLATE

- M2 x 8 TP Screws (2) 
- M2.6x8 Bind TP Screws (4) 
- M3x6 Flat TP Screw (1) 
- M3x8 TP Screws (2) 
- M3x10 TP Screws (2) 
- 117 Radio Post Screws (2) 

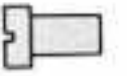

36 INSTALLATION OF SPEED CONTROL

- M2.6 x 6 Bind Screw(1) 
- M3 Nuts (Gold Color)(2) 
- 31 Ball Nut (1) 
- 92 Speed Control Nut (1) 
- 93 Speed Control Contact Points(2) 
- 95 Speed Control Pivot (1) 

38 INSTALLATION OF SPEED CONTROL PC BOARD

- M2.6 x 6 Bind Screw(1) 
- M3 x 10 Screws (2) (Gold Color) 
- M3 Nuts (3) (Gold Color) 
- 91 Speed Control Spring (1) 
- 94 Speed Control Stud (1) 
- 98 Driver Post (1) 

40 SPEED CONTROL LINKAGE

- 37 Ball End (S) (1) 
- 104 Servo Rod (1) 

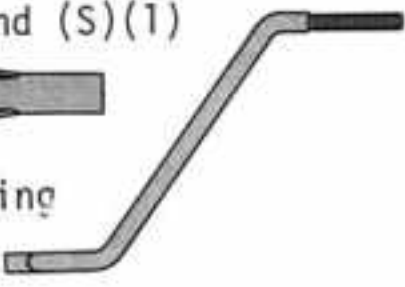

41 INSTALLATION OF STEERING ROD

- 37 Ball End (S)(1) 
- 113 Steering Rod (1) 





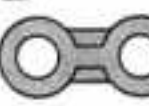

43 INSTALLATION OF RECEIVER AND ANTENNA

- M2.6 Washers (2) (Black Color) 



44 INSTALLATION OF FRONT STABILIZER

- M3 x 3 Set Screws(2) 
- 149 Stabilizer Links(S)(2) 
- 150 Stabilizer Pivot Balls (2) 

45 INSTALLATION OF REAR STABILIZER

- M2.6 x 6 Bind Screws (2) 
- M3 x 3 Set Screws(2) 
- M2.6 Nuts (2) 
- 147 Stabilizer Stoppers (2) 
- 148 Stabilizer Links (L)(2) 
- 150 Stabilizer Pivot Balls (2) 



46 INSTALLATION OF BUMPER

- M3 x 12 TP Screws(2) 
- M4 x 8 Bind Screw(1) 
- M4 Flanged Nut (1) 

47 MOUNTING THE WHEEL

- M2 x 8 TP Screws (16) 



48 INSTALLATION OF TIRES

- M4 Nylon Nuts (4) 
- 110 Drive Washers(4) 
- 131 5ø Shims (4) 

52 MOUNTING OF DRIVER

- 66 Hook Pin (1) 

53 MOUNTING OF BODY

- 66 Hook Pins (2) 
- 132 Body Washers(2) (Transparency Plastic Washer) 

PRINTED IN JAPAN

AFAJ5T