

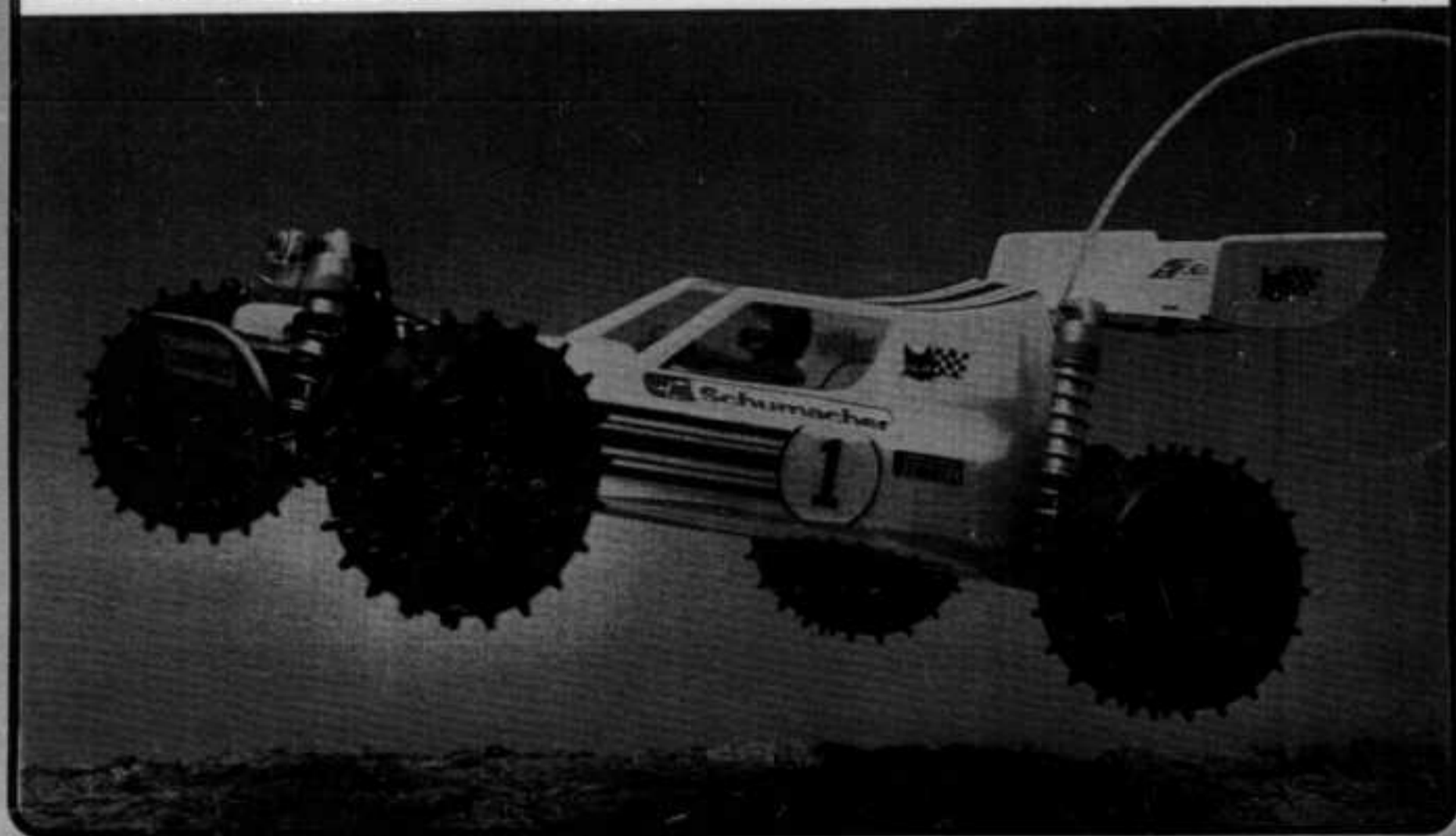

Schumacher

CAT

COMPETITION ALL TERRAIN



T400 Standard Wheelbase 4 Wheel Drive
T401 XL Long Wheel Base 4 Wheel Drive
T402 XL Long Wheel Base 2 Wheel Drive

INSTRUCTION MANUAL

INTRODUCTION

Thank you for buying your Schumacher 'CAT' 1/10th scale off-road racing car. This is a high performance model, engineered and developed by a company with an international race winning reputation. We hope your 'CAT' will provide you with many hours of enjoyment and success on the race tracks.

Time and care spent in building the car will be rewarded with performance and reliability.

To assemble your model, please follow the photographs step-by-step whilst carefully reading the Assembly Instructions. The numbers in brackets on the photographs indicate the bag in the kit where each part may be found.

To avoid confusion, please keep the parts in their correct bags until you actually need to assemble them. The 'Operating Instructions' deal with routine maintenance and adjustments that can be made to the finished model to improve its performance and keep it in top condition.

The separate parts list shows all major items (T500 numbers) in the kit. The individual items are shown in column (3) under 'Part No.'; these are available as spare parts only in the assemblies shown in column (2) under 'Spares No.'. Standard items of hardware may be available from the Schumacher Price List.

The CAT may be built as a 2 wheel drive car by leaving out parts marked thus *.





TOOLS REQUIRED FOR ASSEMBLY

Screwdriver
Spanner 5.5mm A/F
Spanner 1/4" A/F
Drill (for holes in bodyshell & covers)
Circlip pliers (see photograph 68)
Pliers
Vice
Sharp knife
File
Pointed nose pliers or cutters

MATERIALS REQUIRED

Threadlock
Light oil for shock absorbers
Polycarbonate paint for bodyshell
Motor, batteries, radio control equipment, speed controller

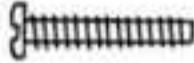
SCREW IDENTIFICATION CHART

	CH HD	Cheese head
	CSK HD	Countersunk head
	PAN HD	Self tap thread
	CAP HD	Cap Head

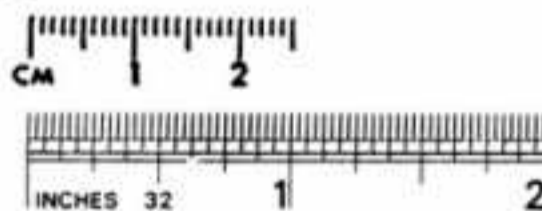

These instructions cover the following models
T400 Standard wheelbase 4 wheel drive
T401 XL long wheel base 4 wheel drive
T402 XL long wheel base 2 wheel drive

ASSEMBLY INSTRUCTIONS

Photos 1-6

These photographs identify the components on the major mouldings in the kit.

- T032 Side pulley rear 51t
- T033 Centre pulley rear 51t
- T034 Front pulley 50t

T617 PULLEY MOULDING 51-50T (T519)

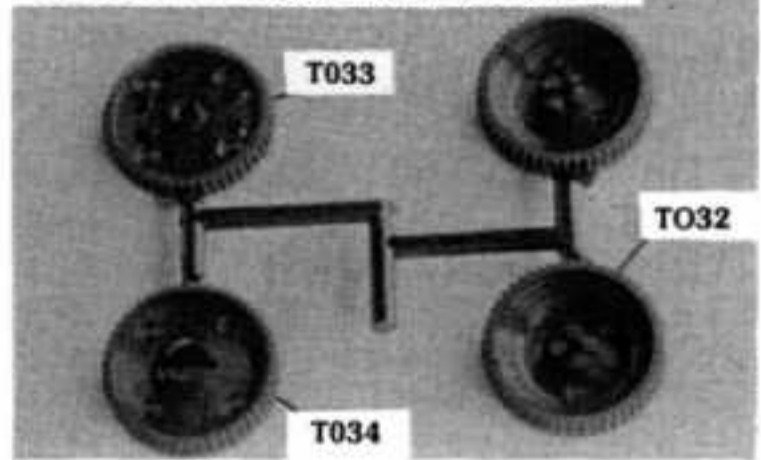

1

T618 PULLEY MOULDING 21T & BALL CAGE (T519)

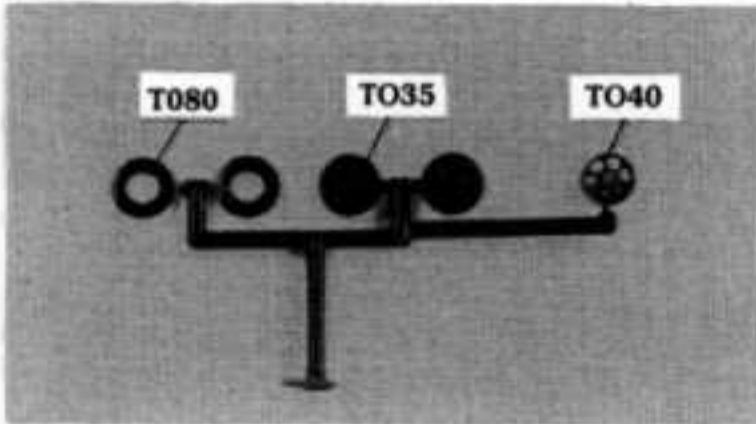

- T035 Diff. pulley 21t
- T040 Ball cage
- T080 Flange - 21t pulley

2

T613 SPRING STOPS & SPACERS MOULDING (T511)

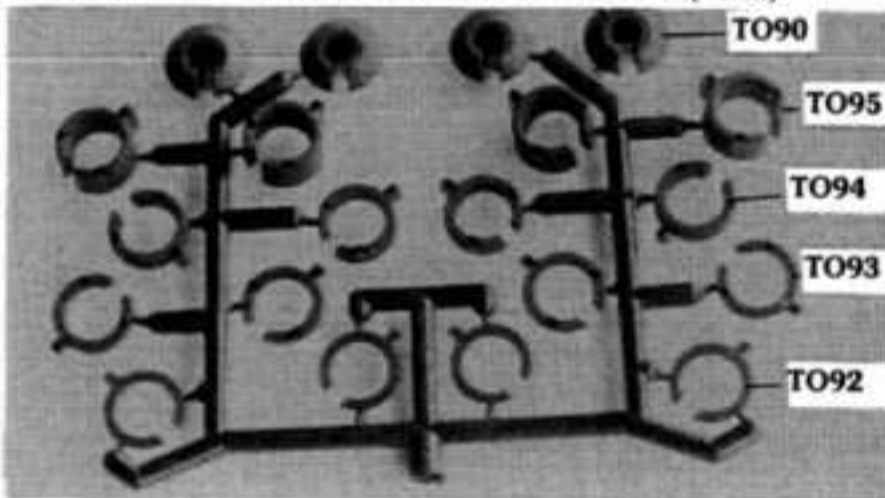

- T090 Spring stop
- T092 Spring spacer 1.0mm
- T093 Spring spacer 2.0mm
- T093 Spring spacer 2.0mm
- T094 Spring spacer 4.0mm
- T095 Spring spacer 8.0mm

3

- T029 Front hub
- T030 Wheel hub
- T031 Rear hub

T612 HUB MOULDING

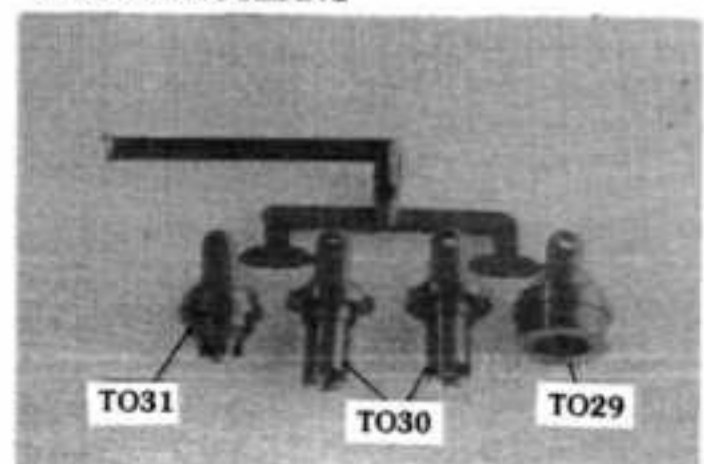

4

- T056 Bracket A front suspension
- T057 Bracket B front suspension
- T076 Mounting bracket
- T101 Servo mount

T518 BRACKET MOULDING

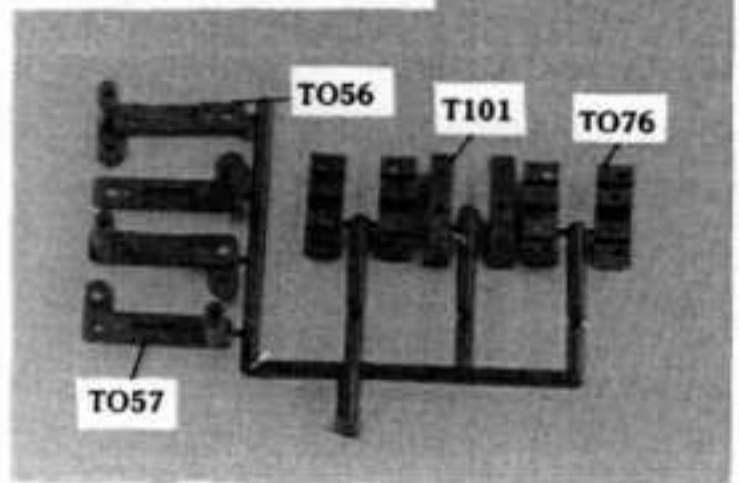

5

T517 BEARING HOUSING MOULDING

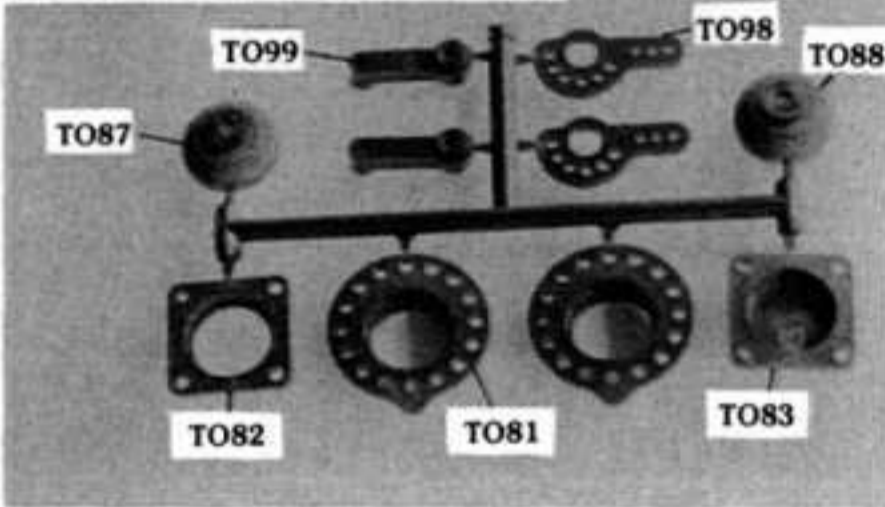

6

Photo 7

Fix the T081 eccentric bearing housing with only two screws because it will need to be adjusted later.

- T081 Rear bearing housing - eccentric
- T082 Diff. bearing housing - open
- T083 Diff. bearing housing - closed
- T087 Thrust washer carrier liner (drive teeth)
- T088 Thrust washer carrier outer (plain)
- T098 Steering lever
- T099 Radius arm

- A301 Self tap screw No.2 x 3/16" Pan hd.
- T072 Cover plate
- T081 Rear bearing housing eccentric
- T083 Diff. bearing housing closed

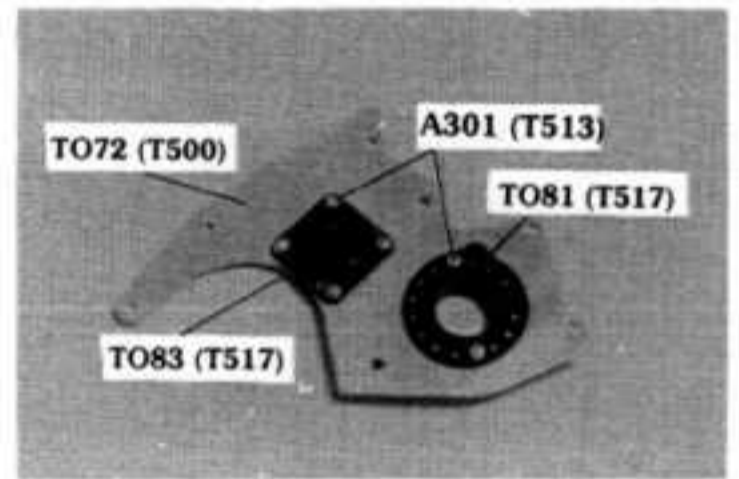

7

Photo 8

Kits may be supplied with two types of 8x16x5 Ball Race. The A530 has two brown non-contact seals and the A533 has one brown non-contact seal and one black contact seal. The black seal should face the dirtiest conditions.

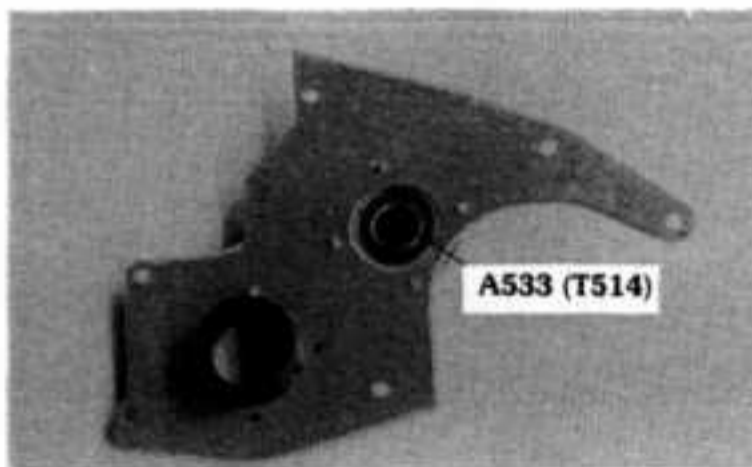

8

Photo 9

See comment (8) above.

A533 Ball race 8 x 16 x 5 NF

- A301 Self tap screw No. 2 x 3/16" Pan hd.
- T073 Motor plate
- T081 Rear bearing hsg eccentric
- T082 Diff. bearing hsg - open

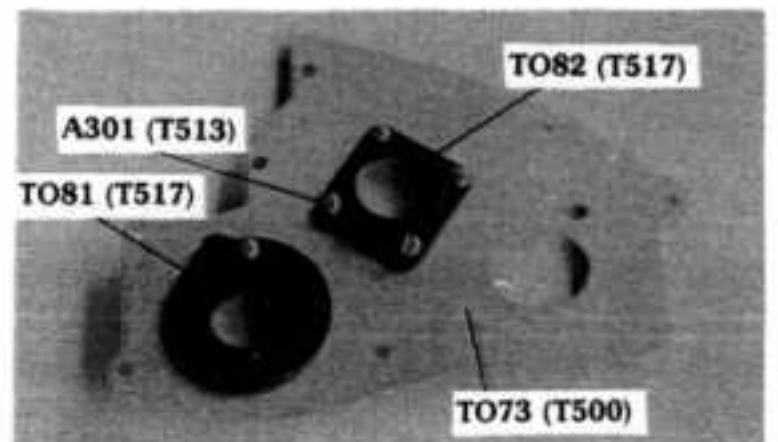

9

Photo 10

Press pulley side washers onto pulleys and assemble parts onto differential shaft in the order shown. The A401 pin, the T085 shaft and T035 pulley may be permanently glued together. Make sure the A500 ball cage spins freely on shaft. Lightly lubricate the balls with silicone grease.

Fit together the drive teeth of the other pulley and T087 washer carrier and make sure the shaft is free. Use 1/8" diameter drill if tight and re-assemble in same angular position.

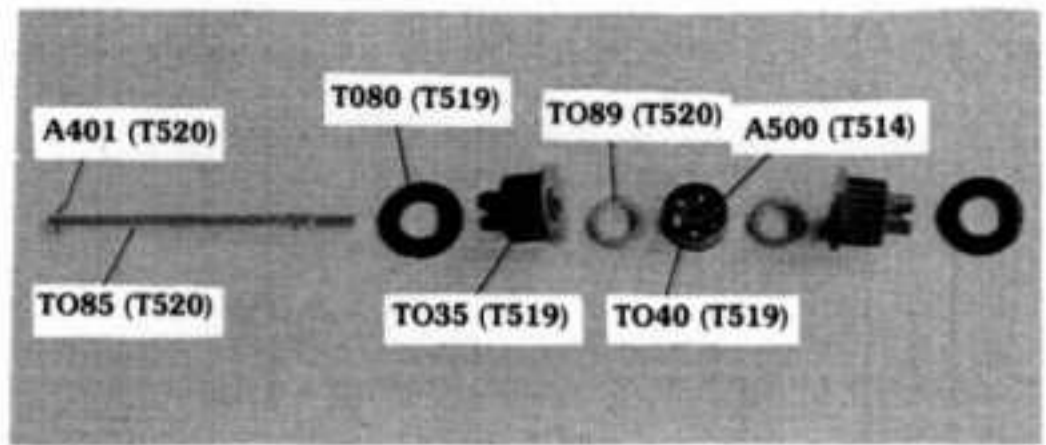

10

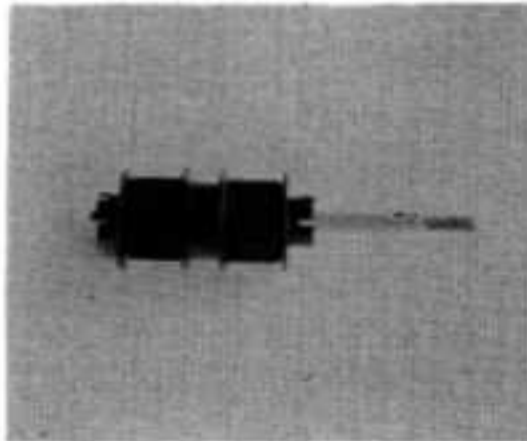

11



- A401 Needle roller 1.5 x 7.8mm 
- A500 Steel ball Ø 3mm
- T035 Diff. pulley 21t
- T040 Ball cage
- T080 Flange - 21t pulley
- T085 Diff. shaft
- T089 Thrust washer 6 x 11 x 1.5mm

Photo 12

Epoxy A221 thrust washer to T087/T088 thrust washer carriers. Complete assembly of differential in the order shown. Lightly lubricate the balls with silicone grease. Note: The A510 bearing does not fully locate in the T124 gear. Use T131 universal joint assembly tool to hold pulley whilst tightening the nut. Do not over-tighten.

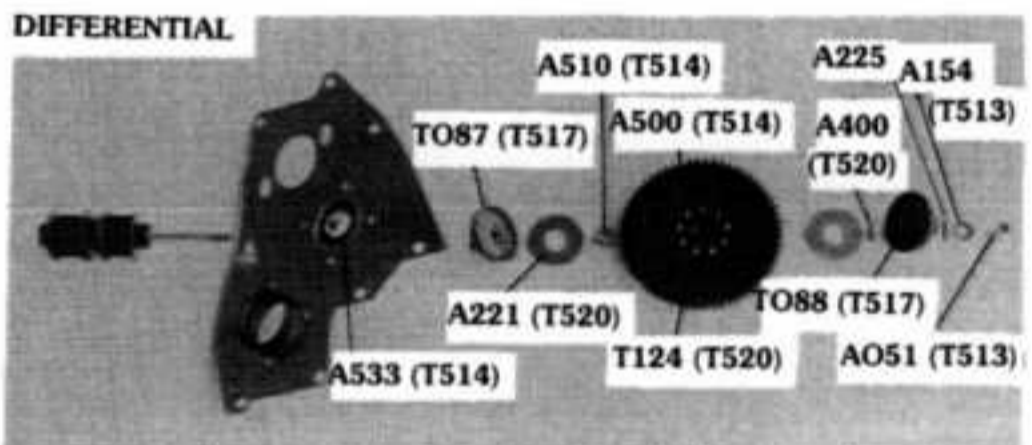

12

- A051 M3 nyloc nut
- A154 Disc spring 1/8"
- A221 Thrust washer 1/4" x 11/16" x 1/32" (diff. gear)
- A225 Steel washer
- A400 Needle roller 1.5 x 5.8mm 
- A500 Steel ball Ø 3mm

- A510 Ball race 1/8" x 1/4" NF
- A533 Ball race 8 x 16 x 5 NF
- T087 Thrust washer carrier inner (drive teeth)
- T088 Thrust washer carrier outer (plain)
- T124 Diff. gear 58t

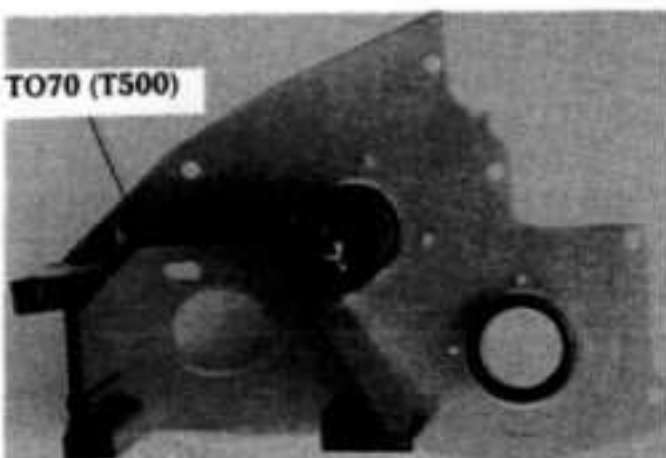
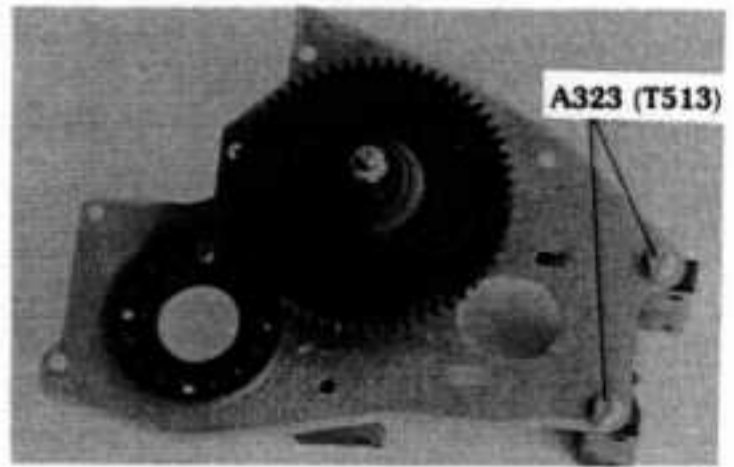

Photo 13

Tighten the differential nut until, when the two small pulleys are held stationary, the gear is just tight.

T070 Rear transmission hsg. inner

13

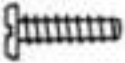

14

A323 Self tap screw No.4 3/8" pan hd. 

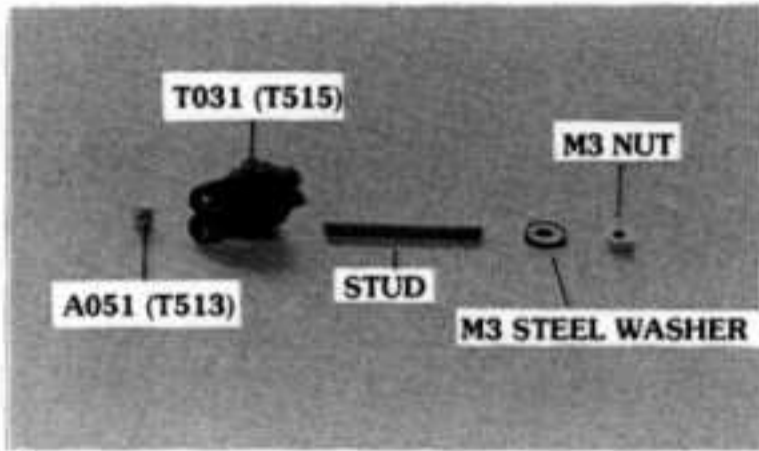

15

Photo 15

A051 nyloc nut fits into T031 rear hubs and must be pulled into the hexagonal recess

- A051 M3 nyloc nut
- T031 Rear hub

Photo 17

Assemble the integrator parts in the order shown. Epoxy the A220 thrust washers to the T032 side pulleys. Lightly lubricate the balls with silicone grease.

INTEGRATOR

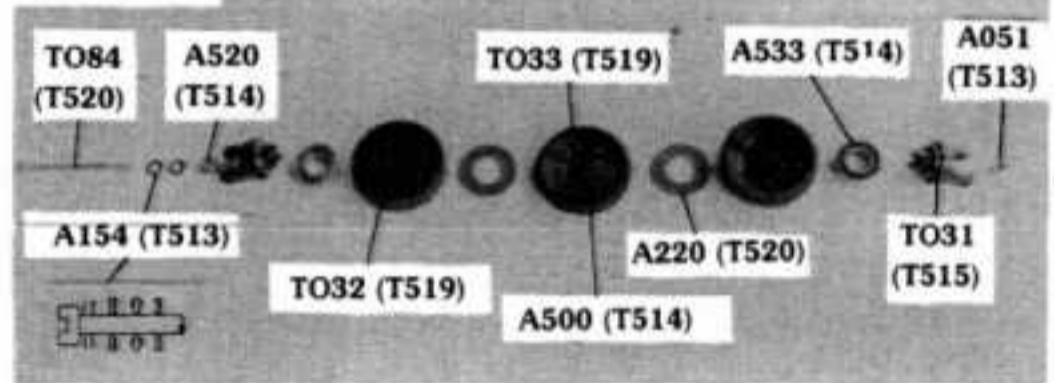

16

- A051 M3 nyloc nut
- A154 Disc spring 1/8"
- A220 Thrust washer 3/8" x 13/16" x 1/32"
- A500 Steel ball Ø 3mm
- A533 Ball race 8 x 16 x 5 NF

- A520 Thrust race 1/8 x 5/16
- T031 Rear hub
- T032 Side pulley rear 51t
- T033 Centre pulley rear 51t
- T084 Rear axle

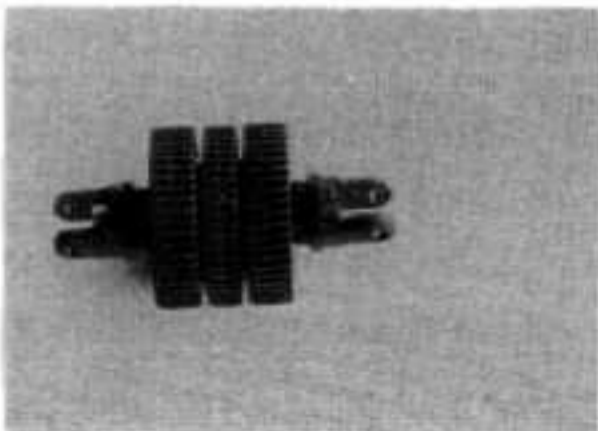

17

Photo 17

Do not overtighten at this stage, just ensure that washers are centrally located on the pulleys and that the assembly works with a smooth, free action without end float. No further adjustment is required for a 2 wheel drive car. See Operating Instructions on page 20 for 4 wheel drive adjustments.

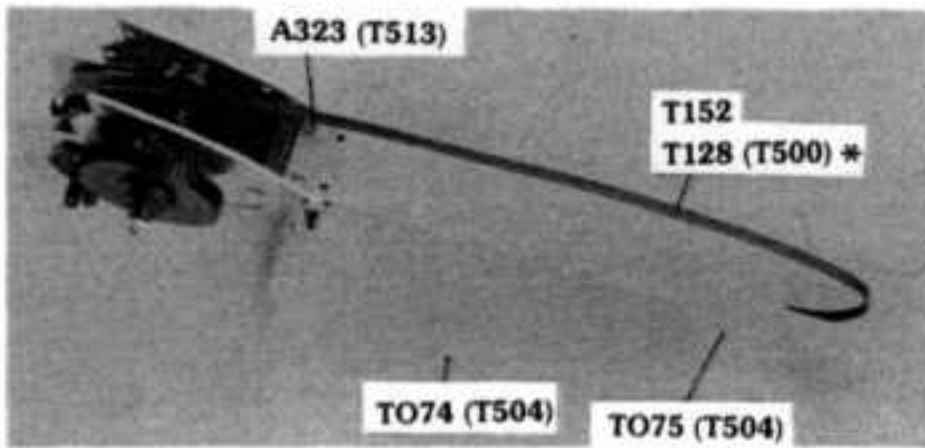

19

Note: For 'XL' long wheel base car use:
 T146 Chassis plate lower (T534)
 T147 Chassis plate upper (T534)
 T152 Drive belt long*

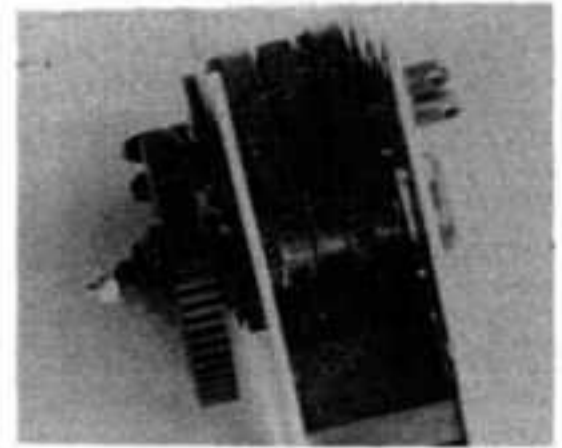

18

A323 Self tap screw No.4 x 3/8" Pan hd
 T074 Chassis plate - lower
 T075 Chassis plate - upper
 T128 Drive belt - long*

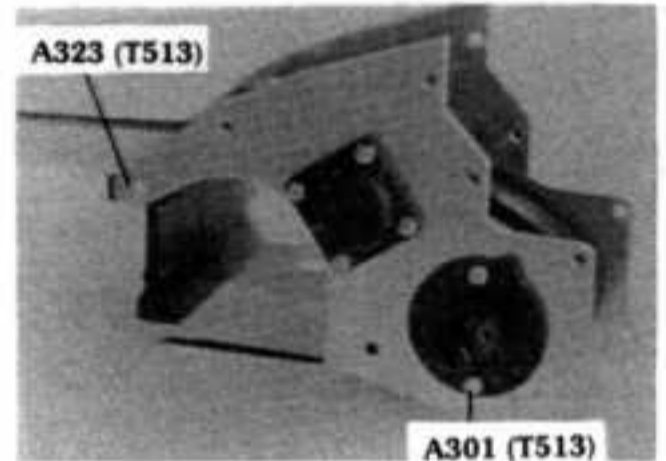
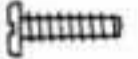

20

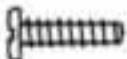
A323 Self tap screw No.4 x 3/8" Pan hd. 

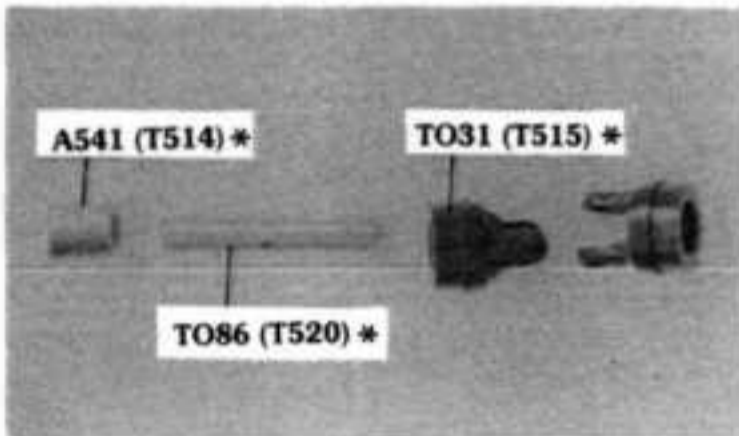

21

Photos 21-23 *

These show the pressing of the A541 one-way clutch into the T031 front hubs. Assemble the components into a vice as shown and press the one-way clutch in. The T086 front axle acts to keep the components square and, when the vice becomes tight on this, it should be removed. The clutch is pressed in only until it reaches the shoulder in the front hub (not flush).

Note: The one-way clutches should be the opposite way round so that the writing is showing on the end of one and not the other, as shown in photograph (23).

A541 One-way clutch 6 x 10 x 12mm *
 T031 Rear hub *
 T086 Front axle *

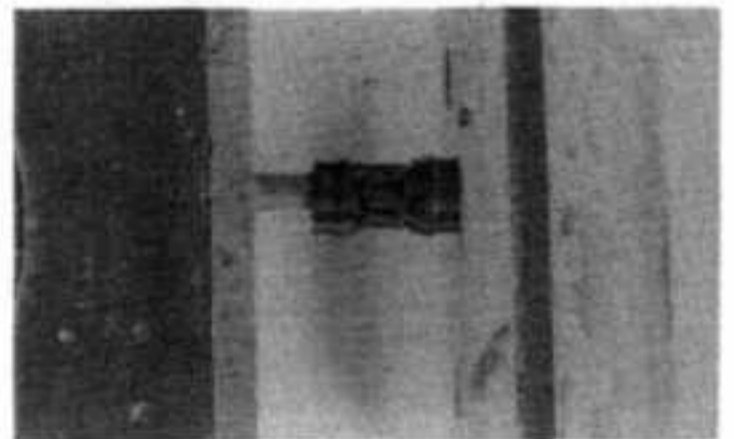

22

ONE WAY CLUTCHES

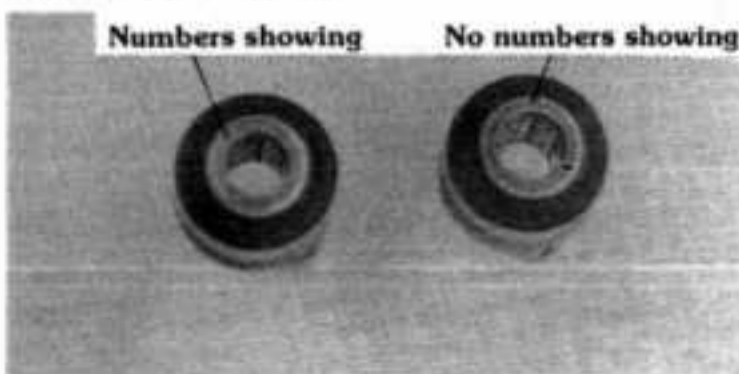

23

* Not required for 2 wheel drive

Photo 24 *

Push T086 front axle into T034 pulley, making sure pin A402 is seated in bottom of slot.

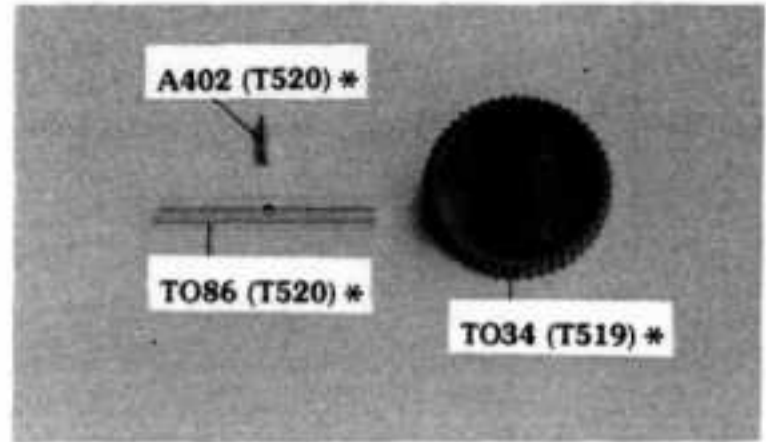

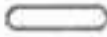
- A402 Needle roller 2.0 x 9.8mm * 
- T034 Front pulley 50t *
- T086 Front axle *

24

FRONT TRANSMISSION ASSEMBLY

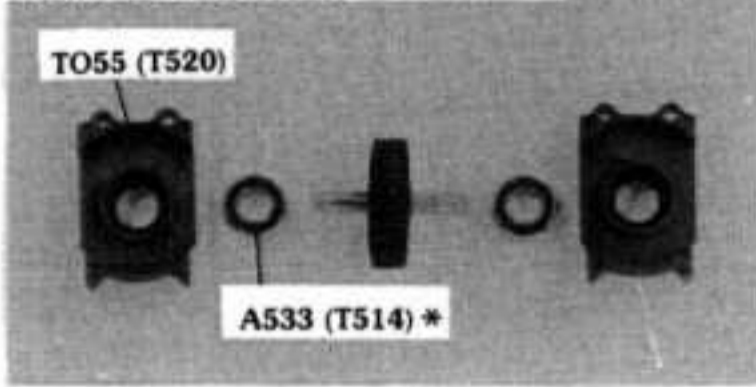

- A533 Ball race 8 x 16 x 5 NF *
- T055 Front transmission housing

25

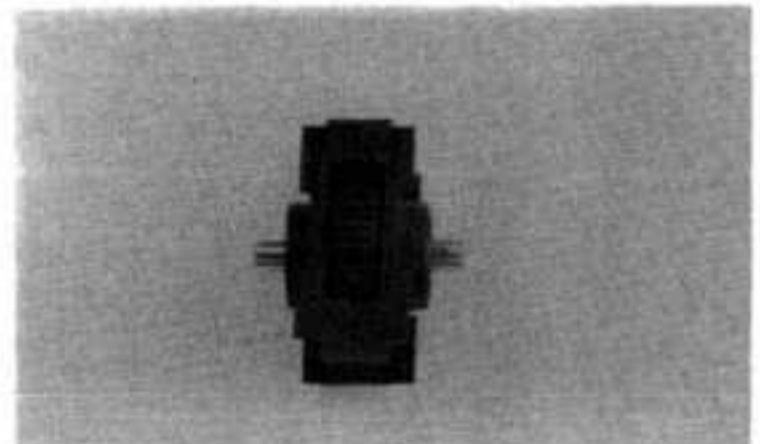

26

Photo 27 *

Rotate front transmission housings until they are at 90 degrees to each other to insert the long drive belt.

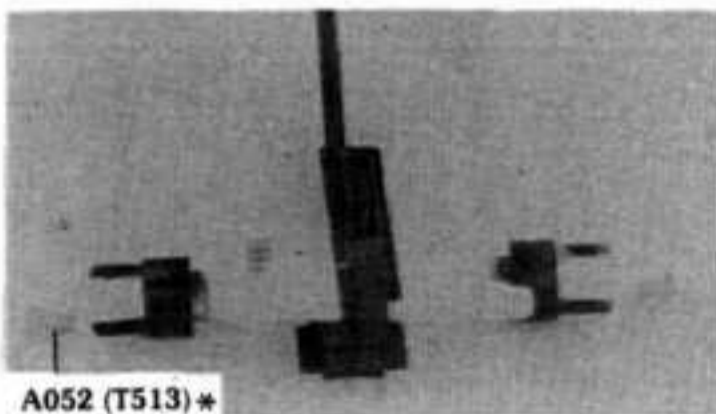

- A052 Aluminium screw M4 x 8 Csk. Hd. 

27

Photo 28 *

The front hubs should be assembled so that they are free to turn in the forwards direction. Swap them around if this is not the case. Firmly tighten A052 screws, photograph (27), whilst holding pulley.





* Not required for 2 wheel drive

28

Photo 29

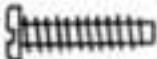
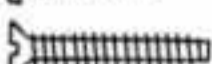
These brackets join the two chassis plates and also clamp the T055 front transmission housing. The A214 bumper spacers fit between the lower chassis plate and the bumper not shown (which will be fitted a later stage.)

- A324 Self tap screw No.4 x 1/2" Pan Hd. 
- A214 Nylon spacer 
- A336 Self tap screw No.4 x 3/4" Csk. Hd. 
- T056 Bracket A front suspension
- T057 Bracket B front suspension

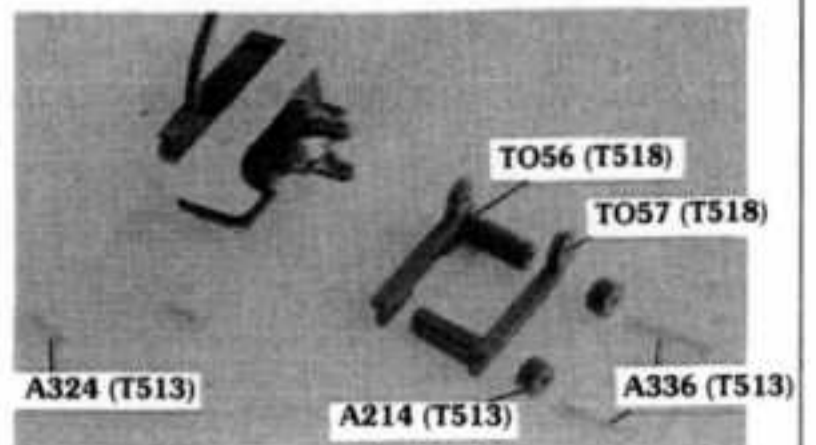

29

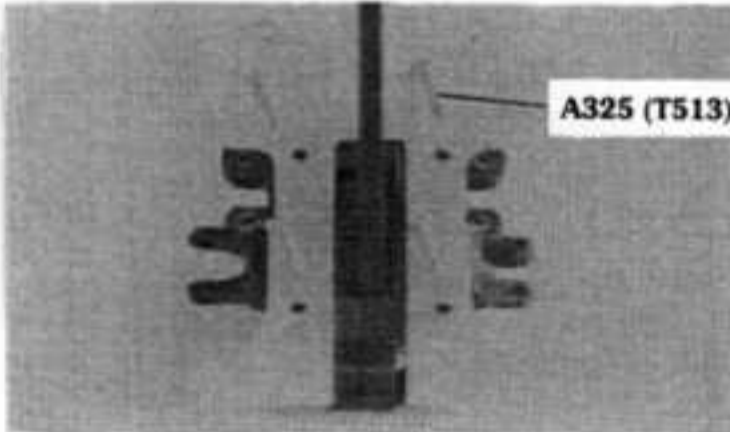

30

- A325 Self tap screw No.4 x 5/8" pan Hd. 

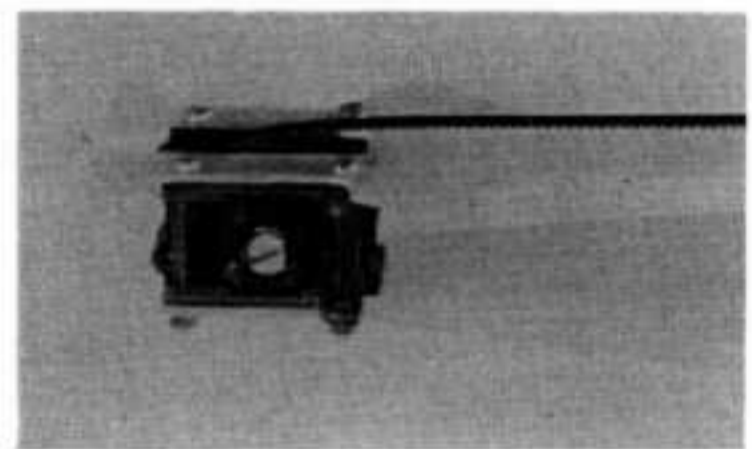

31

Before the T071 outer transmission housing is fitted the belt tension should be adjusted. Always adjust short belts first. The point on the outside of the T081 eccentric-bearing housing shows the adjustment position, when the point is towards the differential centreline then the belts are at their slackest.

Remove the A301 screws and rotate the housing, moving the point downwards until light finger pressure on the belt causes between 1 and 2mm of movement. Replace A301 screws readjust if necessary. Both bearing housings should be at the same setting. Later the long drive belt will be adjusted when the bumper and undertray are finally fitted.

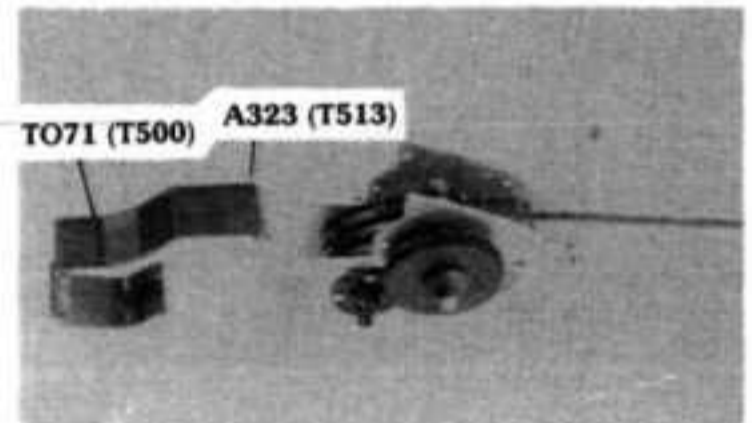

32

- A323 Self tap screw No.4 x 3/8" pan Hd. 
- T071 Rear transmission hsg - outer

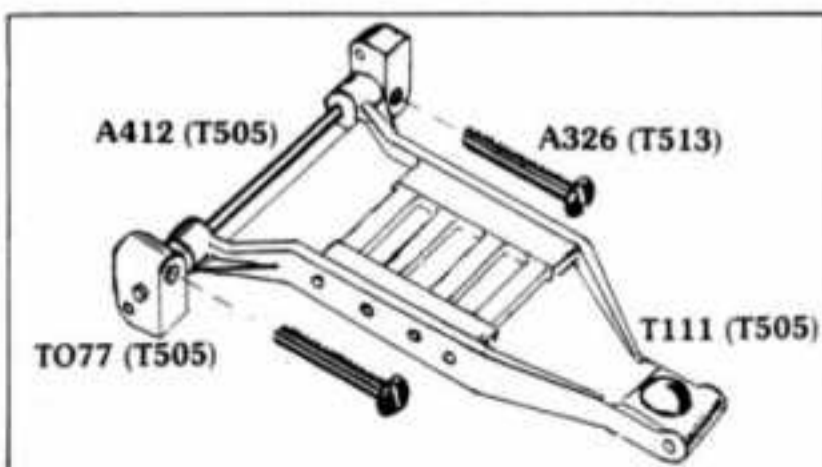

33

Photo 33

The pins should be inserted in the T077, lower rear suspension pivots.

The T077 pivot moulding adjacent to the diff gear will require trimming to allow clearance for the larger gears.

- A326 Self tap screw No.4 x 3/4" pan Hd. 
- A412 Stainless steel pin 2 x 54mm
- T077 Lower rear suspension pivot
- T112 Lower wishbone B

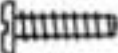
- A323 Self tap screw No.4 x 3/8" pan Hd. 
- T076 Mounting bracket
- T105 Fibreglass rear suspension bracket

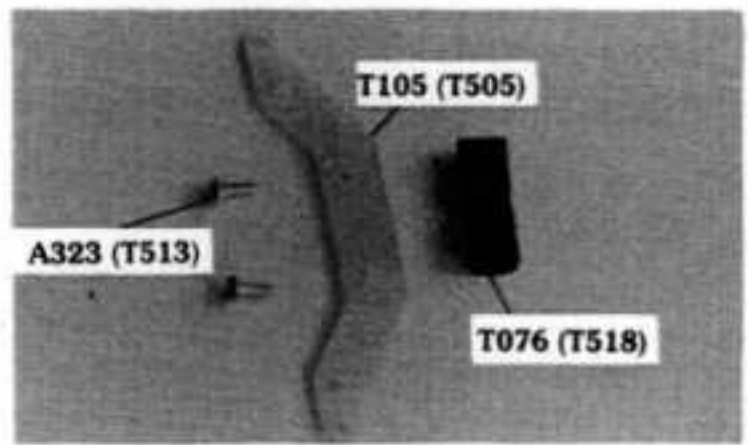

34

Photo 35

Make sure top wishbones fit freely over T079 pivots. Put in screw A326 before pin to make assembly easier.

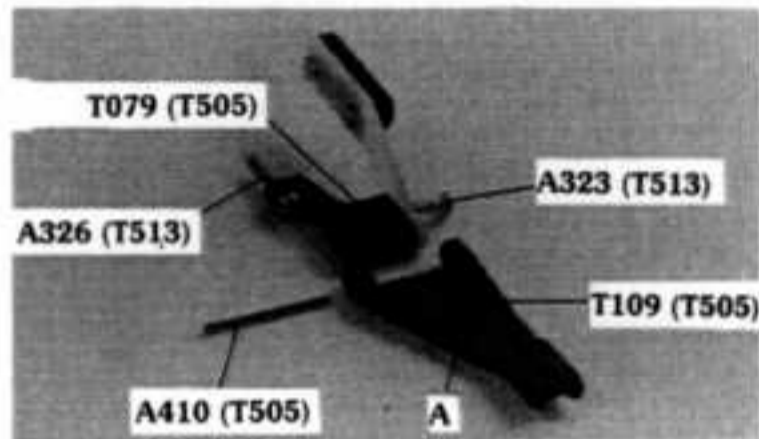

35



- A323 Self tap screw No.4 x 3/8" pan Hd. 
- A326 Self tap screw No.4 x 3/4" pan Hd. 
- A410 Stainless steel pin 2 x 26mm
- T079 Upper rear suspension pivot
- T109 Upper wishbone A

Photo 38

Wishbones are identified 'A' or 'B' and should be fitted as shown. Fully assemble T045 ball pivot to A092 stud using thread lock to secure, and assemble to upper pivot T079 as in photograph (62), stud end should be well below ball surface.

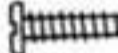

36

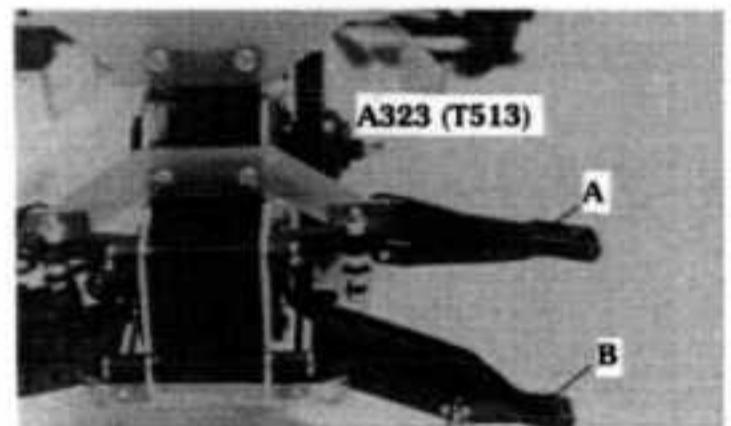
- A323 Self tap screw No.4 x 3/8" pan Hd.

Photo 37

Shows fitting of rear shock bracket.

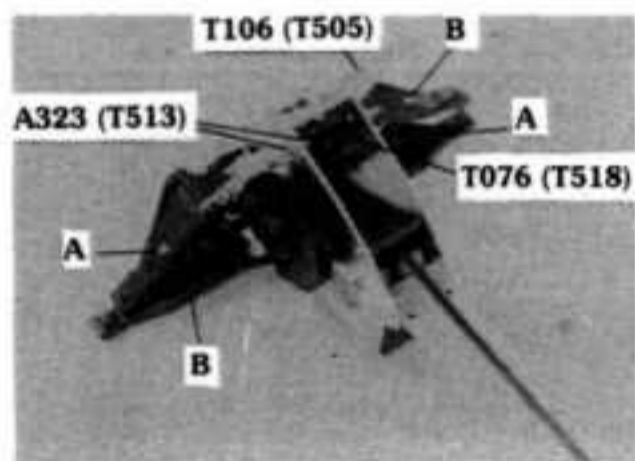

37

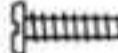
- A323 Self tap screw No.4 x 3/8" pan Hd. 
- T076 Mounting bracket
- T106 Fibreglass rear shock bracket

Photos 38-40

The front suspension assembly may be carried out as shown in the photographs.

- A324 Self tap screw No.4 x 1/2" pan Hd. 
- T006 Pivot bracket - front
- T058 Arm - front suspension



38

A180 'O' ring 1/8"
 A411 Stainless steel pin 2 x 40mm
 T112 Lower wishbone B



40

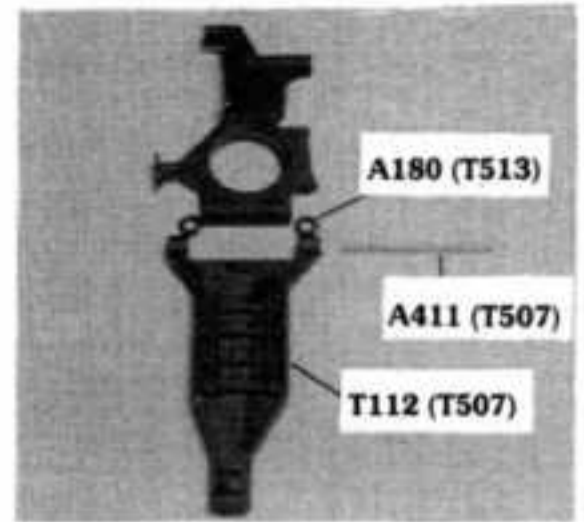

39

A411 Stainless steel pin 2 x 40mm

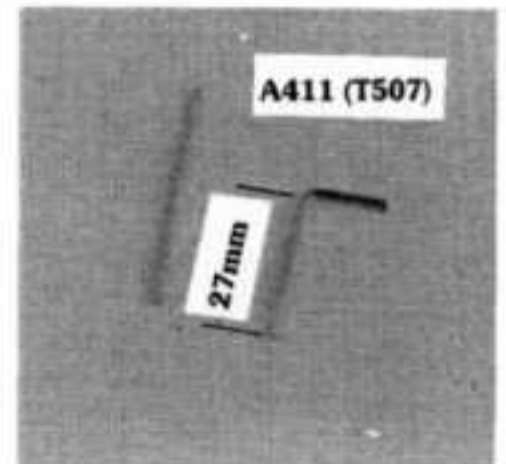

41

Photo 41

Bend the A411 swivel pin neatly and accurately as shown (see template)

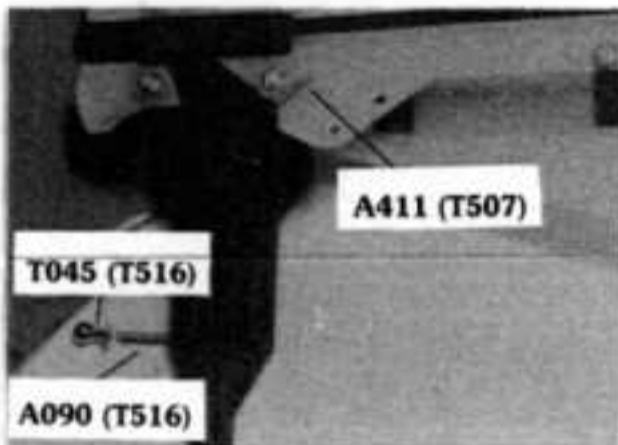

42

Photo 42

Run the A090 stud right to the end of the thread in the T045 pivot ball and secure with thread lock before fitting to the wishbone; make sure stud is below ball surface.

A411 Stainless steel pin 2 x 40mm
 A090 Stud M3 x 12
 T045 Pivot ball

Photo 43

Make sure T109 top wishbone swings freely on T058 arm before fitting A410 pivot pin.

A410 Stainless steel pin 2 x 26mm
 T109 Upper wishbone A

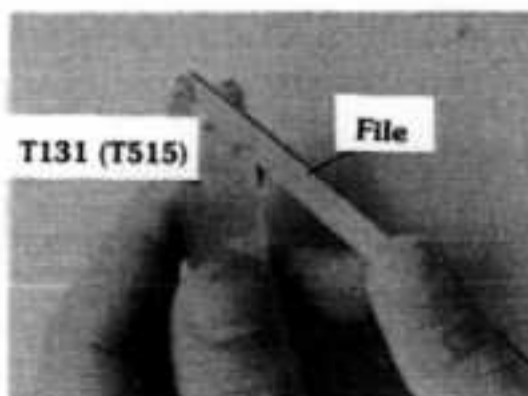
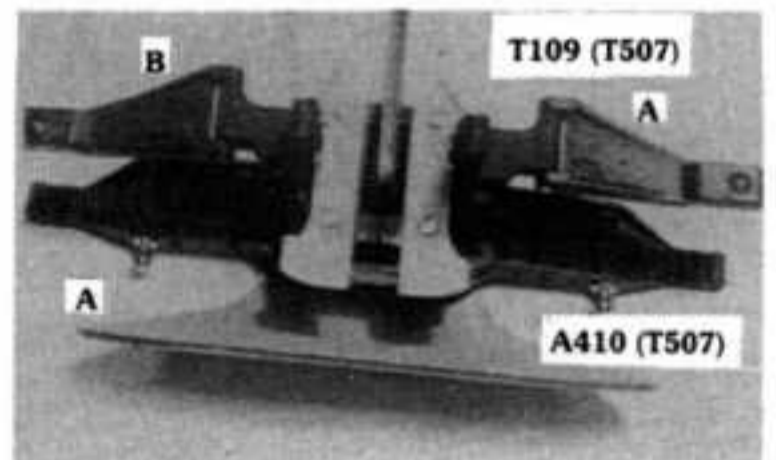

44

Photo 44

File the sharp corners from the mouth of the T131 universal joint assembly tool. Before assembly, secure the pin in the T108 universal joint with epoxy in the centre only.

T131 Universal joint assembly tool

Photos 45-54

These photographs show the procedure for assembling the drive shafts, hubs and universal joint pivot assemblies (T515). This is made easier by warming the moulded parts in hot water.

Note: In photograph (45) the universal joint pivot assembly is pushed in from the side to start, using the spherical surface to part the lugs. After photograph (53), use the universal joint assembly tool as in photographs (47-49).

The assembly of the universal joints requires close attention to these instructions. Once the technique is acquired joint assembly becomes a simple task. The reliability and efficiency of this system makes the effort worthwhile.

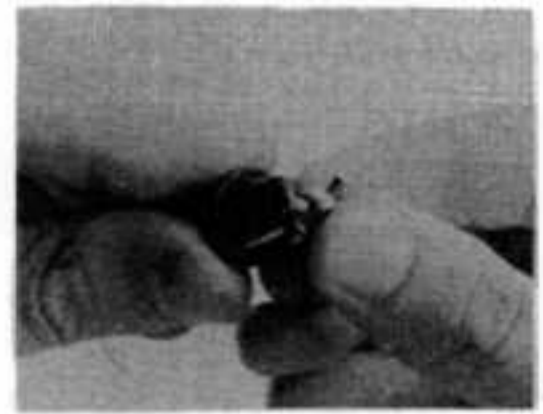

45

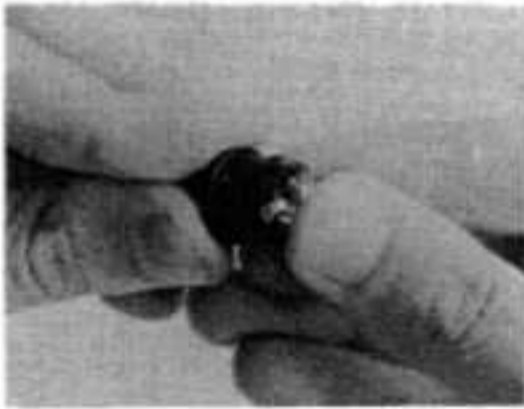

46



47

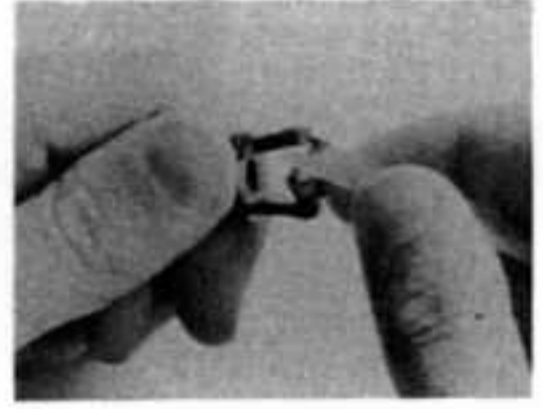

48

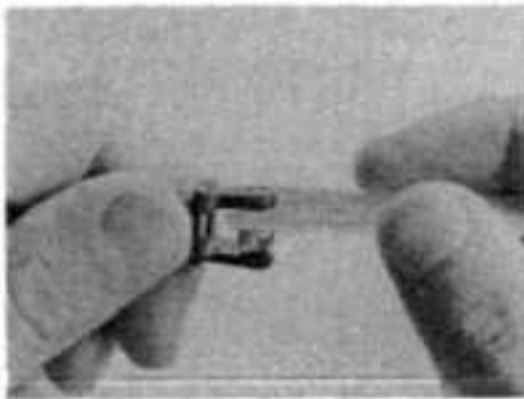

49

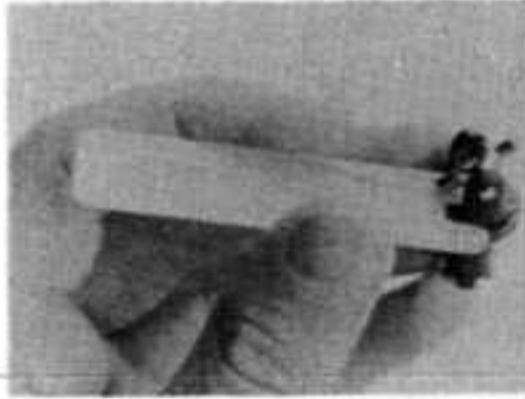

50



51

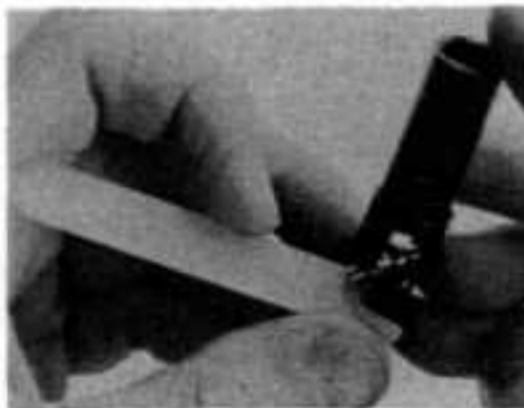

52



53

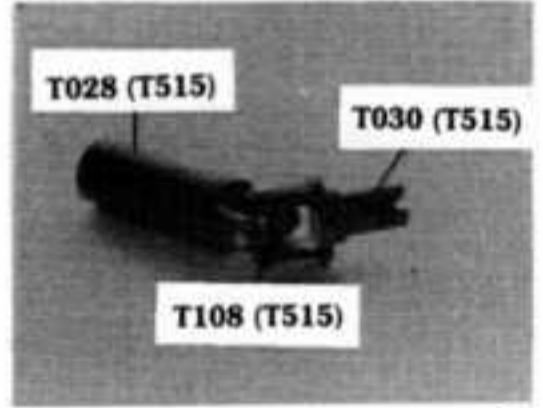

54

T028 Drive shaft - outer
T030 Wheel hub
T108 Universal joint pivot assembly

Photo 55

Repeat this for rear of car.

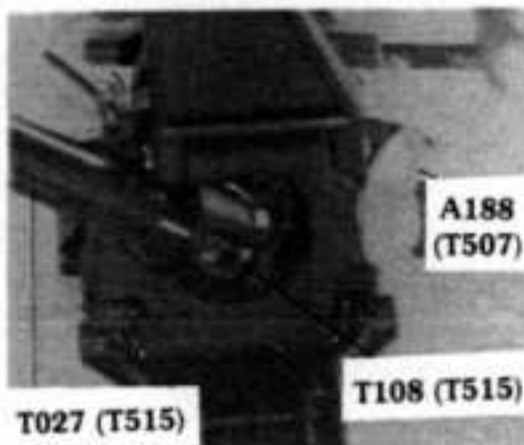

55

A188 Tension band
T027 Drive shaft - inner
T108 Universal joint pivot assembly

Photo 56

Shows assembly of T045 pivot balls into the front and rear hub carriers. Note: The steering control balls are towards the rear of the car. Similarly, the rear track control balls are towards the rear. This makes a left and right assembly of each. Spacer washers A206 are fitted under steering pivot ball, and will be adjusted later. The front upper pivot ball retaining screw needs a small flat filing on the side of the head which prevents the screw from rotating. Use the hexagon of the ball joint to tighten. Two bearings are placed in each hub carrier, one from each side. The upper wishbone pivot balls are retained by A012 8mm screws and the remaining pivot balls by A013 10mm screws.

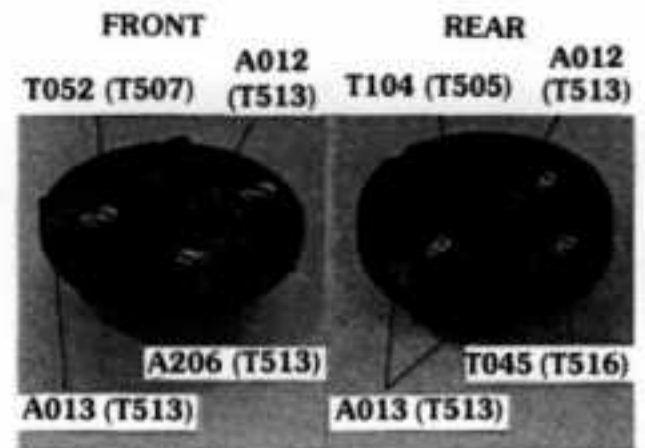

T052 Hub carrier - front

T104 Hub carrier - rear

A012 Aluminium screw M3 x 8 CL Hd. 

A013 Aluminium screw M3 x 10 Cl Hd. 

A206 Nylon washer 3.3 x 8.0 x 1.6

T045 Pivot ball

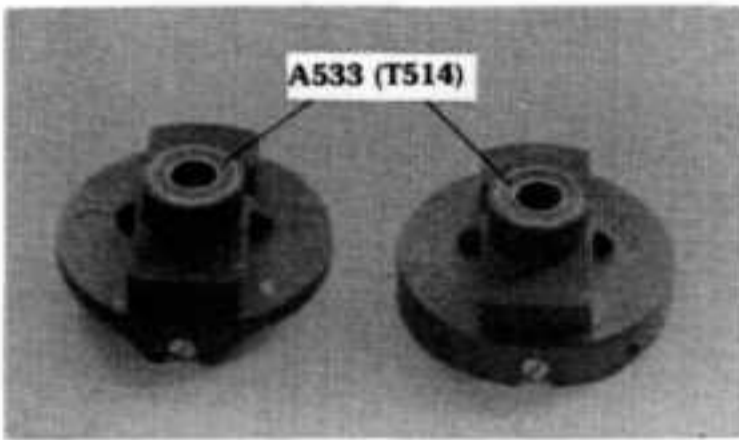

57

A533 Ball race 8 x 16 x 5 NF

Photos 57-58

Assemble bearings and drive shafts as shown.

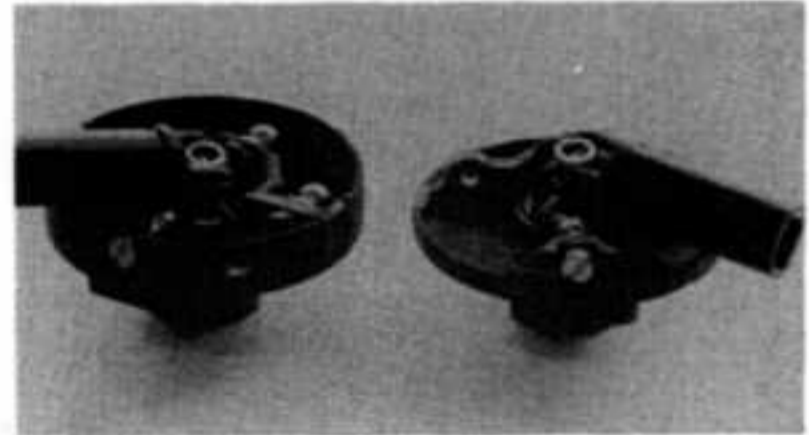

58

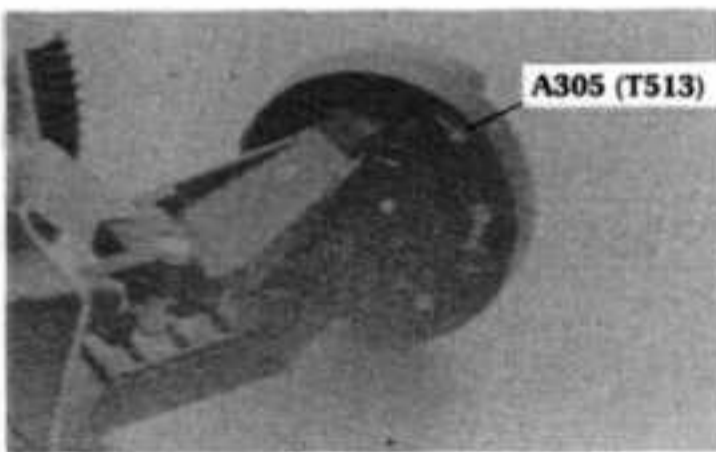

59

Photo 59

Spring wishbones into position before fitting A304 clamp screws; tighten to take out excessive clearance. Carefully file small amounts of material from wishbones to allow full steering movement at extremes of suspension movement.

A305 Self tap No.2 x 1/2" pan Hd. 

Photos 60-61

Centre track rod assembly. Note: T098 lever can be assembled either side of the car and in a variety of positions. Lock bushes tight to fibreglass. Ensure levers move freely. Apply thread lock to all threads.

T045 Pivot ball

T098 Steering lever

T099 Radius arm

T116 Fibreglass centre track rod

A301 Self tap screw No.2 x 3/16" pan Hd. 

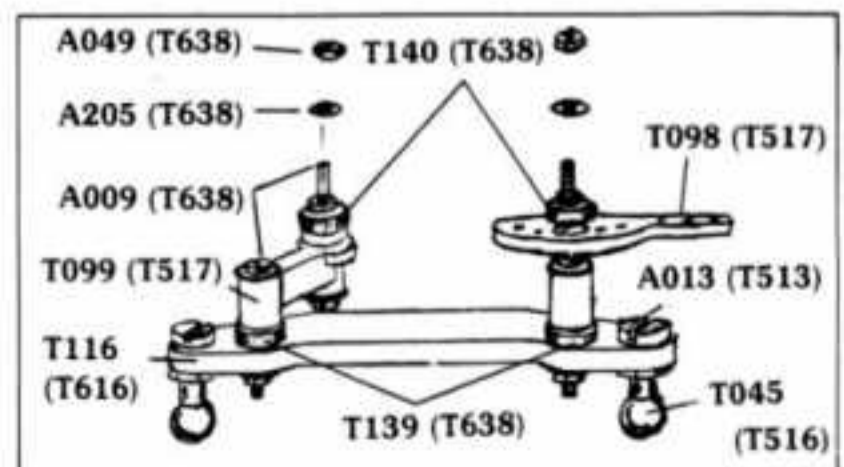

60

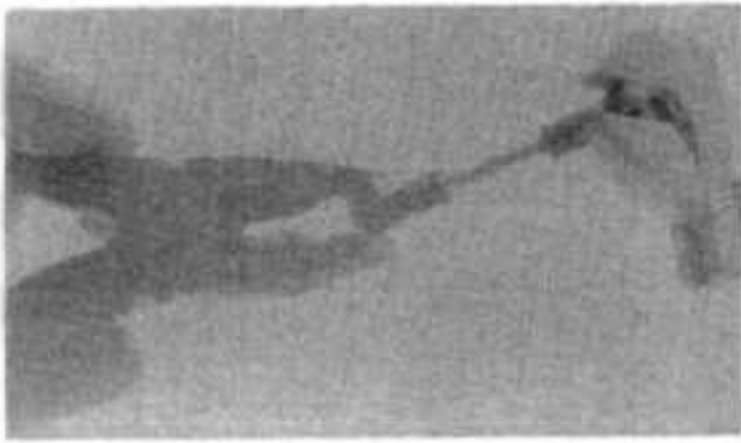

61

A050 Aluminium nut M3
 A092 Stud M3 x 24
 T045 Pivot ball

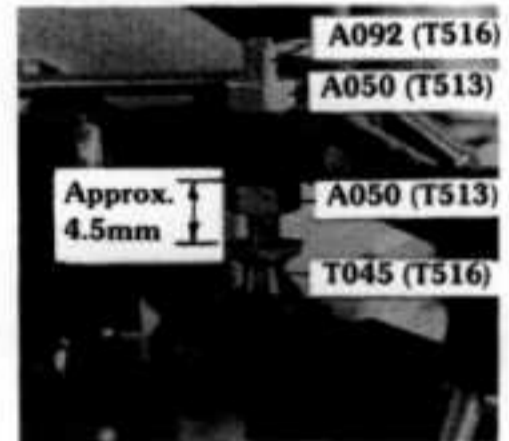

62

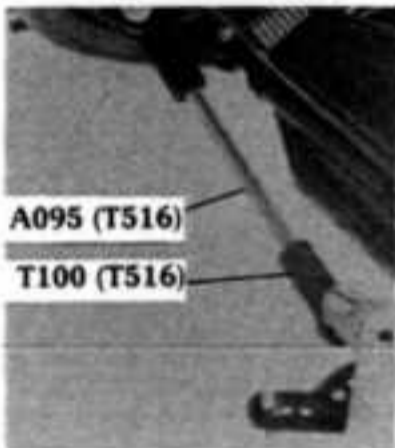

63

A095 Stud M3 x 45
 T100 Ball socket

Photos 62-63

Set rear track rods at approximately 54mm between ball centres, (62mm overall) and front at 63mm between centres (71mm overall). The wheels should remain parallel over the full range of suspension movement. Adjusting the height of the rear track rod pivot will alter this. The front can be altered by changing the spacer washers in the hub carrier. File a little material off the front in-board ball socket to clear the chassis at full lock.

Photo 64

Shows order of assembly of shock absorber seals. Note direction of lip on A170 seal and recess for wiper 'O' ring A181 in T064 bush. Apply light oil before fitting.

A131 Circlip 8mm
 A170 'U' seal 1/8" x 5/16"
 A181 Silicone 'O' ring 1/8"
 A209 Black washer 3.3 x 7.8 x 0.8
 T061 Shock absorber body - 32mm stroke
 T064 brass bush

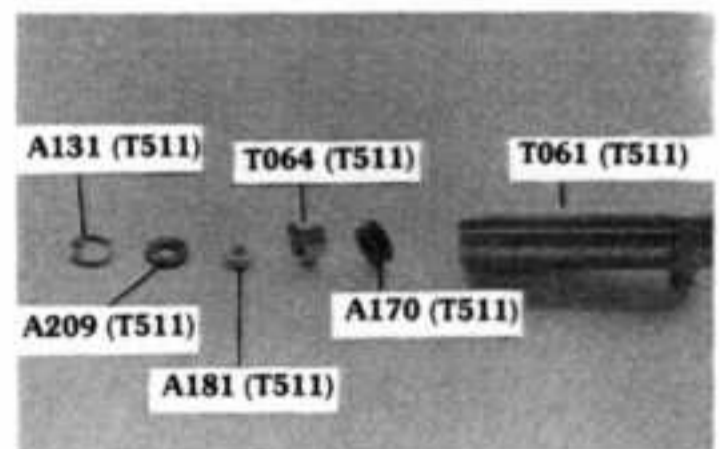

64

Photo 65

Good quality circlip pliers are essential.

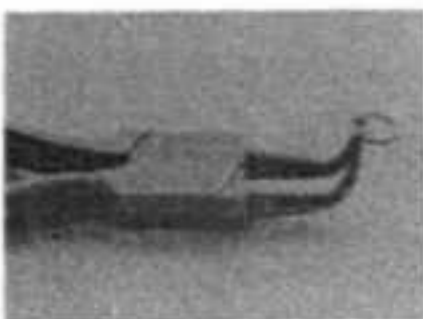

65

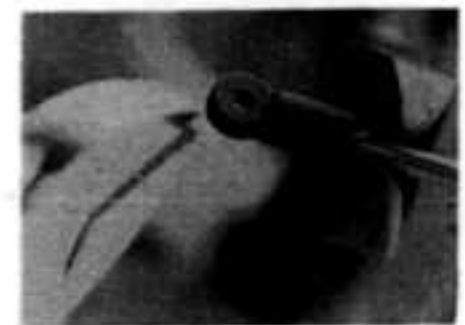
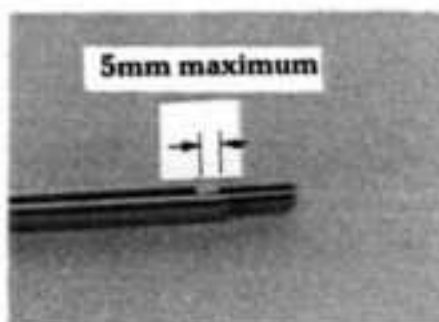
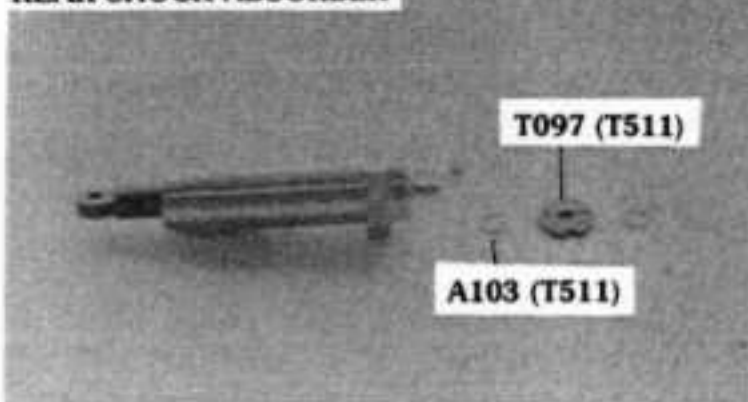

Photo 66

Deburr circlip grooves and threads on piston rod T062/T063 before assembly to avoid damage to seals. To hold the piston rod whilst screwing on the T113 rod end, file two flats on the shaft as shown in photograph (65a), then hold with a pair of cutters. Take care not to damage the main part of the piston rod as this will cause the shock absorbers to leak. Always fit the rod into the body from the bottom to avoid damaging the lip seal. Assemble T097 piston (large notch) to the long rod for the rear shock absorber. Assemble T096 piston (small notch) to the short rod for the front shock absorber, with 4mm of spacer washers under the piston to limit the wheel drop. Before filling with oil ensure piston moves freely through full length of stroke, carefully relieve if necessary.

REAR SHOCK ABSORBER



A103 'E' clip 1/8" x .012"
T097 Piston 2sq. mm hole (rear)

66

REAR SHOCK ABSORBER

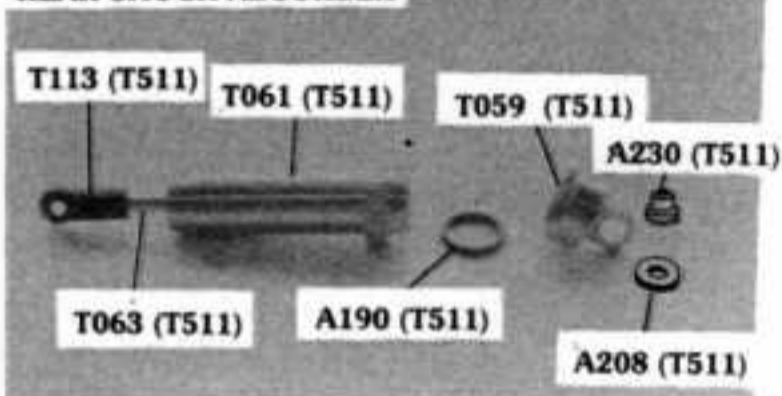

67

Photo 67

With the piston rod fully extended, fill the shock absorber with a light oil. Work the piston up and down to release any trapped air. Assemble the 'O' ring seal and cap with the piston at its upper most position. Note: The 'O' ring fits inside the cap. A190 'O' ring ID 9mm x 1.6
A208 Nylon washer M3 x 0.8
A230 Stepped washer 1/8"
T059 Cap- shock absorber
T061 Shock absorber body - 32mm stroke
T063 Piston rod - 32mm stroke

Photo 68

Repeat this procedure for the front shock absorbers using the short piston rod, short body, short spring, short rod end and the piston with the small hole. Additionally, cut the T117 spacer tube into 6mm lengths and position over the piston rod, against the rod end. This raises the height of the T090 spring stop. Insert spring spacers T092-5 as required to adjust the ride height.

- T090 Spring stop
- T093 Spring spacer 2.0mm
- T133 Suspension spring .045 x 11 (rear)

REAR SHOCK ABSORBER

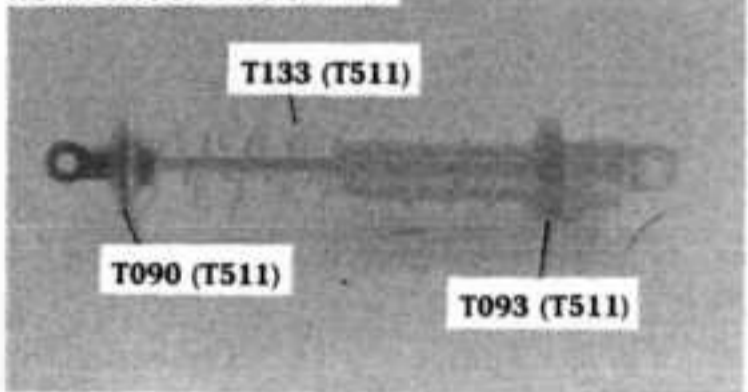

68

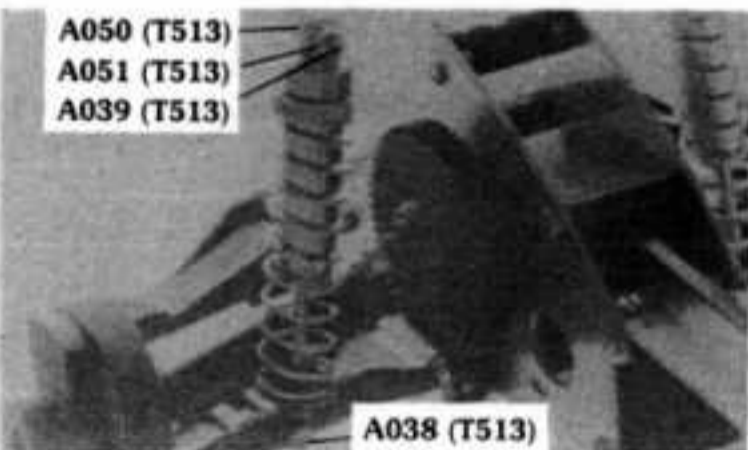

69

Photo 69

Fit lower shock absorber mounting screw first. Back off to allow the top to be fitted without straining the shock absorber. Tighten the top shock absorber mounting, screw to zero clearance and then slacken by one complete turn. A050 Aluminium nut M3
A051 Nut M3 nyloc
A039 Stainless steel screw M3 x 16 cap Hd.
A038 Stainless steel screw M3 x 12 cap Hd.

Photo 70

A188 tension band fits over lugs on T006. Bands should be lapped several times to provide enough tension to firmly hold front wheels in position under racing conditions

- A188 Tension band
- A038 Stainless steel screw M3 x 12 cap Hd.

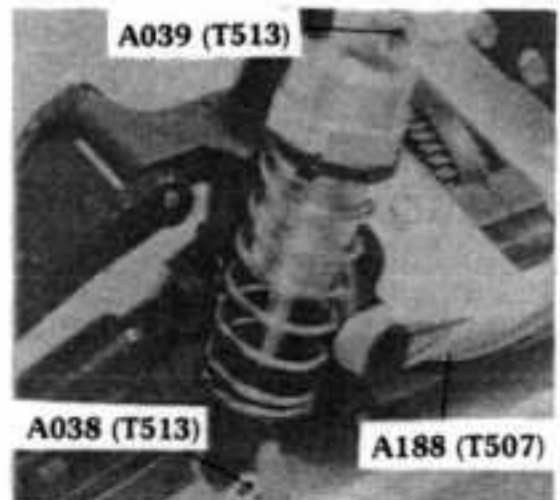

70

Photo 71

C058 nicad clamp locates as shown, and will remain in position with nicads removed. For added convenience, saw a screwdriver slot in the ends of the A040 screws to allow operation from above and avoid the need for an access hole in the undertray.

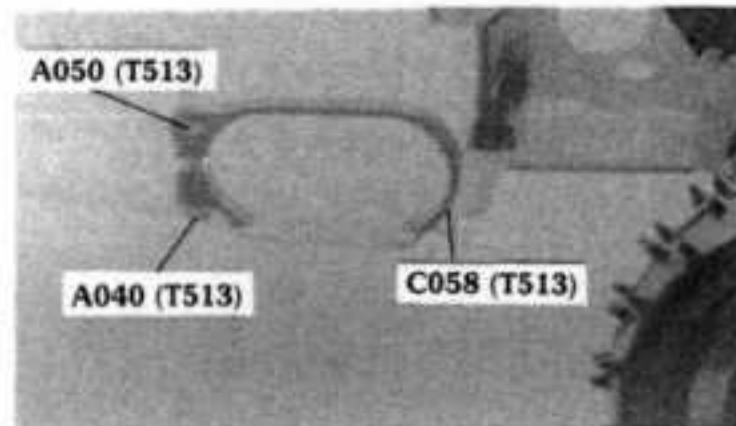

- A040 Stainless steel screw M3 x 20 cap Hd.
- A050 Aluminium nut M3
- C058 Nicad clamp

71

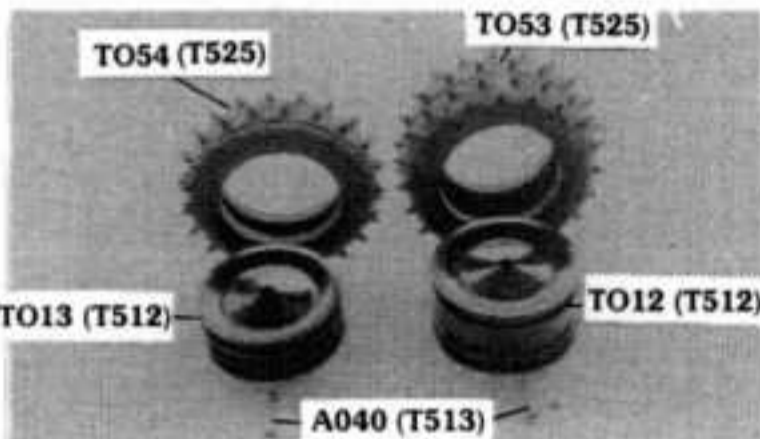

72

Photo 72

The A040 wheel retaining screws screw into A050 M3 nyloc nuts (bag T513) which fits inside the wheel hubs. Ensure that the nuts are pulled into the hubs as in photograph (16).

- A040 Stainless steel screw M3 x 20 cap Hd.
- T012 Rear wheel
- T013 Front wheel
- T053 Rear tyre
- T054 Front tyre

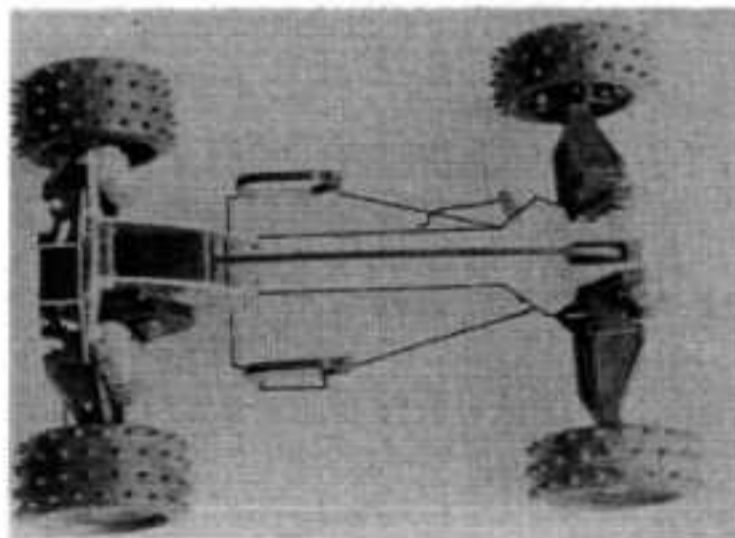

73

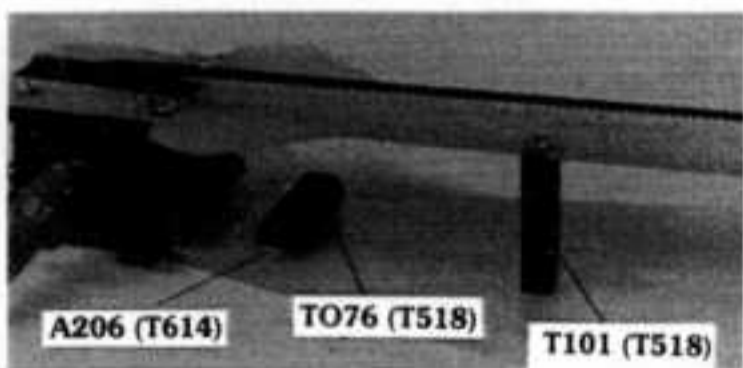

74

Photo 74

Servo mounting posts.

- A206 Nylon Washer
- T076 Mounting bracket
- T101 Servo mount

Photos 75-76

Select the servo saver fitting for your servo and assemble as shown.

SERVO SAVER

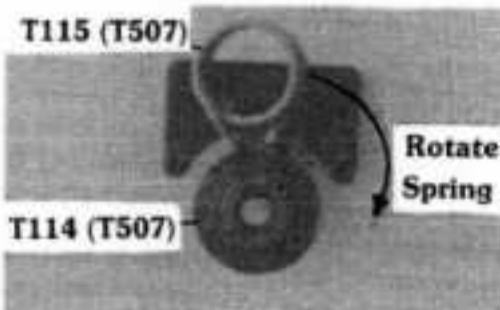

75

- T114 Servo saver moulding
- T115 Servo saver spring



76

Photo 77

Bend the A422 servo link wire to suit your servo position. Also see photograph (73).

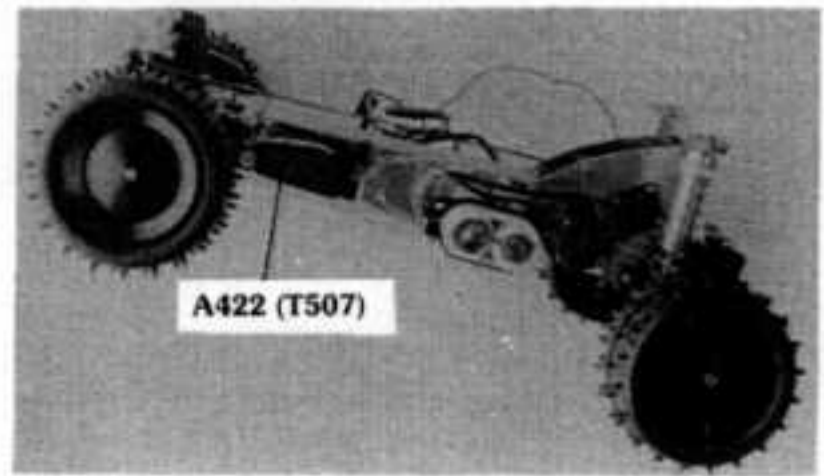

77

A422 Wire link - servo saver

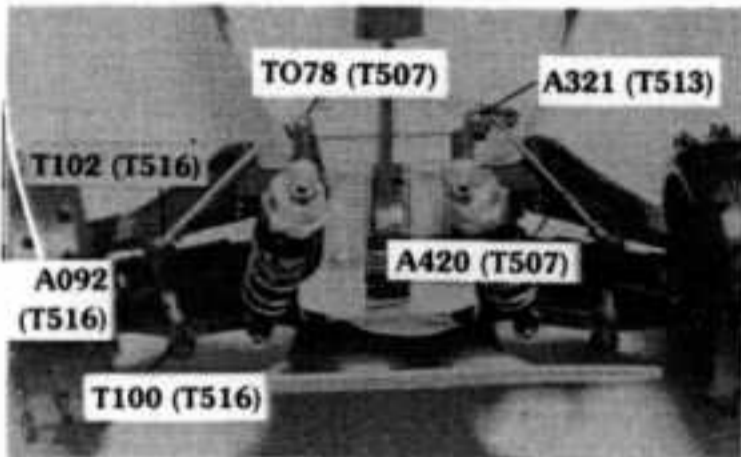

78

A092 Stud M3 x 24

A321 Self tap screw No.4 x 1/4" pan Hd.

A420 Wire 1.6 x 180mm

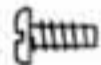

Photo 78

Bend the front and rear anti-roll bars and wing clamp as shown in the templates on page (). Note: The T102 rod end ball differs from the T045 pivot ball in that it is not threaded. Solder or epoxy the T102 rod end balls to the anti-roll bar wire. Fitting the rear anti-roll bar is the same procedure. The clamp grooves will need enlarging slightly to accommodate the thicker wire.

T078 Wire clamp

T100 Ball socket

T102 Rod end ball

Photo 79 *

Shows installation of rear anti-roll bar - see photograph (42) for fitting of lower pivot balls. Vary the position of the lower pivot ball to adjust the roll stiffness.

A092 Stud M3 x 24

A421 Wire 2 x 135mm

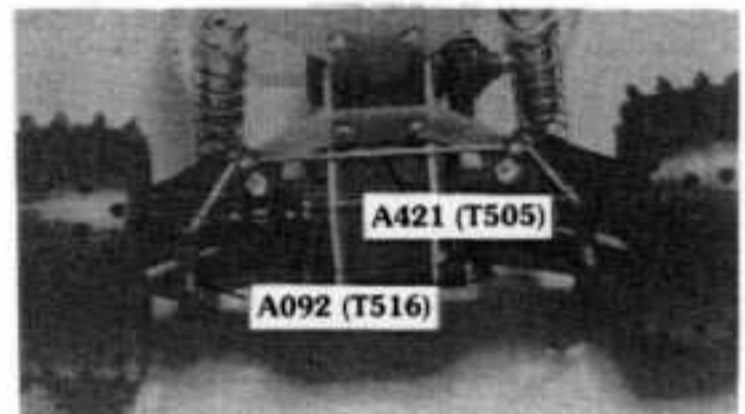

79

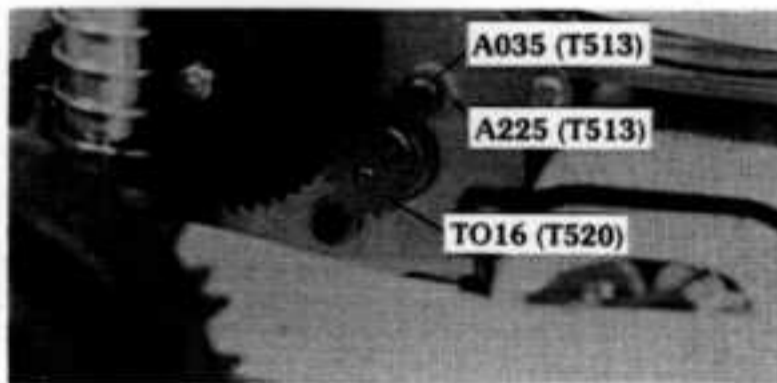

80

Photo 80

Install motor using cap head screws and washers as shown. Gear mesh should never be tight but keep backlash to a minimum - check over full circumference of differential gear.

A035 Stainless steel screw M3 x 6 cap Hd.

A225 M3 steel washer

T016 Motor pylon 16t

Photos 81-82

Bend the wing mount to the template and clamp it under the rear suspension bracket. Wing is retained by A032 steel screw, A208 washer on top and two A180 'O' rings each side underneath, and collar T107 (bag T507).

A032 Stainless steel screw M3 x 6 pan Hd.

A180 'O'.ring 1/8"

A208 Nylon washer M3 x 0.8

A420 Wire 1.6 x 180mm

T107 Collar

* Not required for 2 wheel drive

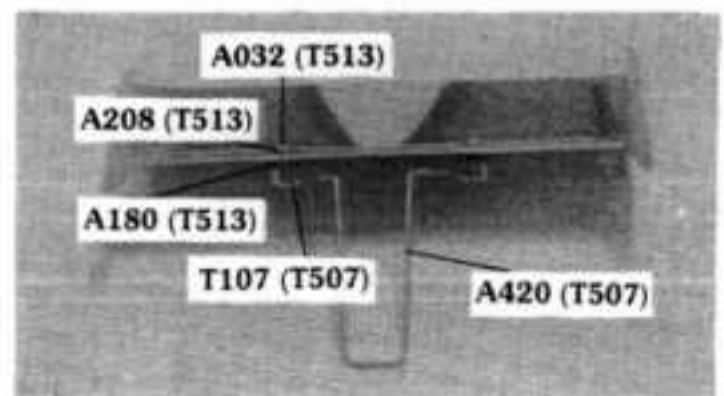

81

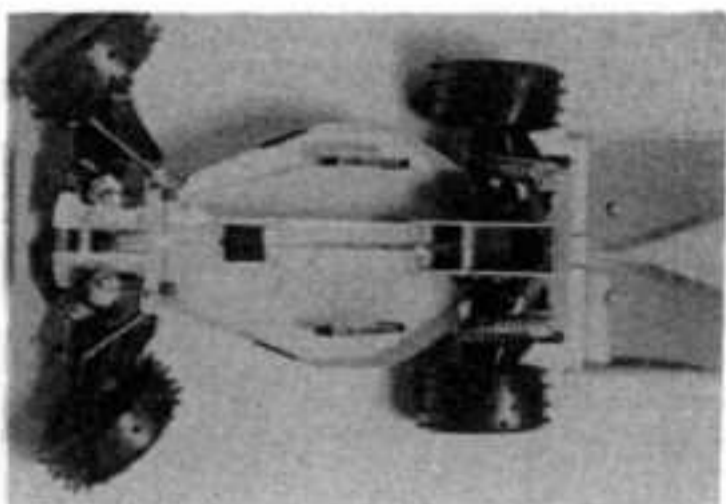

83



82

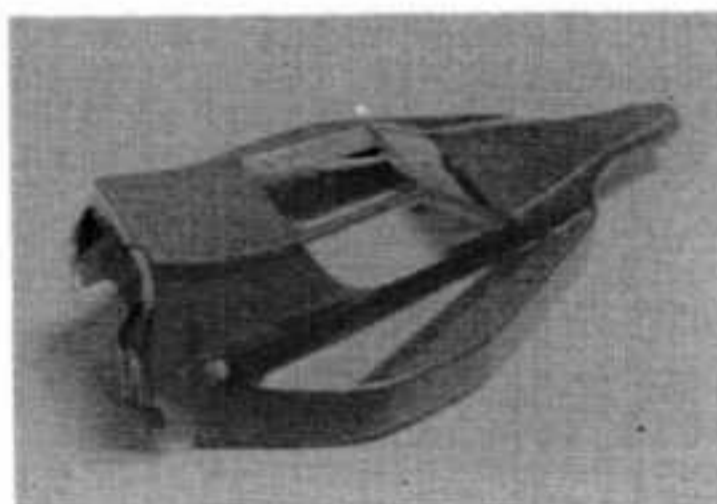

84

Photos 83-84

Mask and paint on the inside, bodyshell and covers before cutting out - use only approved polycarbonate paint such as Flexan, Hobbynox, etc. Spray painting is advisable. Carefully cut to the mould lines and sand all edges.

To fit undertray, place assembled car upside down on bench and carefully remove all lower chassis screws. Remove chassis and use as template to accurately drill holes in undertray; fit chassis, undertray and bumper. Smooth and radius the edges of the bumper for improved strength.

BELT COVER

Note : Rearmost two screws in top chassis do not fix belt cover. Cut two small notches to clear front anti-roll bar. Check hole alignment before piercing and fitting cover.

Bodyshell is retained by two small velcro patches located in recesses in undertray sides. A third patch can be fitted between the belt cover and the bodyshell just in front of the windscreen.

Stick your driver figure on the belt cover.

Motor and gear covers are only necessary under extreme operating conditions. Motor will run cooler without these.

WARNING

Use of motor sprays solvents and oils will attack the polycarbonate material from which your bodyshell and undertray are manufactured. Always remove motor to lubricate and clean.

OPERATING INSTRUCTIONS

- (1) **Bearings** - Before and after running in wet conditions, lubricate the eight wheel bearings with WD40 or a similar water repelling oil. Periodically clean all bearings by removing the shields with a needle and washing with paraffin. Relubricate with light oil.
- (2) **Differential** - The differential should be sufficiently tight so that it does not slip under acceleration. Do not over-tighten. Should the nyloc nut become ineffective an additional locking nut may be used.
- (3) **Integrator 4 Wheel Drive** - To adjust, place screwdriver through slot in axlehead and turn opposite rear wheel, clockwise to tighten. To check, hold the car by the rear wheels with the front wheels on the ground and pull it backwards. For four wheel drive, the integrator should be tightened until the front wheels skid when the above check is carried out. For rear wheel drive only, slacken the integrator until the front wheels just roll freely. Intermediate settings will give a degree of torque transmission through the front wheels. Belt slip is immediately recognisable as a harsh rasping noise particularly on full throttle get away. Always re-adjust tension if slip occurs. Integrator and differential adjustments should be checked regularly. 2 wheel drive CAT - adjust for free operation without end float.
- (4) **Belt Adjustment** - Light finger pressure on short belts at the midpoint between pulleys should produce a deflection of 2mm. Long belt should be slacker. See "Assembly Instructions" (34) for method of belt adjustment. Front belt should be loose when rears are being adjusted.
- (5) **Bump Steer** - The wheels should remain parallel over the full range of suspension movement. Adjusting the height of the rear track rod pivot will alter this. The front can be altered by changing the spacer washers in the hub carrier.
- (6) **Castor Angle** - This may be adjusted by swopping the lower front wishbones to the opposite sides of the car and by moving the 'O' ring spacers.
- (7) **Tow-in** - There should be a small amount of tow-in on both the front and rear wheels, sufficient so that, when free, play is taken up, the wheels become parallel.
- (8) **Shock Absorbers** - The ride height can be adjusted by inserting the spring spacers above the shock absorber spring. Downwards travel is limited by inserting the nylon washers underneath the piston, inside the shock absorber body.
- (9) **Damping** - Damping may be altered by varying the grade of oil used in the shock absorbers.
- (10) **Tyres** - The spikes on the outer edges of the tyres may be cut off to reduce the amount of grip and adjust the handling. If the car turns into corners too tightly, then remove the outer row of spikes from the front tyres.
- (11) **Pivots** - Once the kit has been completely assembled, all the pivot balls should be permanently fixed to the screws using thread lock.
- (12) **Lubrication** - Do not lubricate plastic parts because this attracts dirt and increases wear.
- (13) **Roll Stiffness** - Moving the lower anti roll bar pivots outwards increases the roll stiffness.

'CAT' GEAR RATIOS

Diff. Gear	55T	58T	60T
10	-	-	14.6
11	-	-	13.2
12	-	11.7	12.1
13	-	10.8	11.2
14	-	10.1	10.4
15	8.9	9.4	9.7
16	8.3	8.8	9.1
17	7.9	8.3	8.6
18	7.4	7.8	8.1
19	7.0	7.4	-
20	6.7	7.0	-

NOTE: ABOVE GEAR RATIOS INCLUDE INTERMEDIATE 21/51 TOOTH PULLEYS

Millimetres car travels per rev of motor = mm/rev

mm/rev = $\pi \times \frac{\text{Tyre dia. in mm}}{\text{Gear Ratio}}$ (for CAT 88mm)

Gear Ratio

Suggested ratio for 5 min races

27T Standard Motor 16T Pinion 58T Diff. Gear

19T Modified Motor 13T Pinion 58T Diff. Gear

In general, cars run longer with smaller pinions. Excessively large pinions can overheat motors and cause permanent damage.

OPTIONAL EXTRA NOT KIT ITEM 'CAT' FRONT DIFFERENTIAL ASSEMBLY

- 1 Pull A051 nyloc nut into the hexagonal recess in the T031 hub - use a spare stud and nut as in 'CAT' instruction 14 to force the nut into the recess.
- 2 Push the T080 dust shields onto the hubs as far as possible.
- 3 Trial assemble all parts as in the diagram. The axle must rotate freely in each of the hubs and washer carriers T118.
- 4 Glue the A220 thrust washers to the T118 washer carrier. Use epoxy glue sparingly and make sure washer sits squarely in place.
- 5 Fit 3mm diameter steel balls into holes in T033 pulley and lightly coat with silicone grease.
- 6 Fully assemble all parts starting with T084 axle. Make certain that A154 cone washers are correctly assembled as in diagram.
- 7 Tighten until pulley will just slip under finger pressure when hubs are held.
- 8 Fitting to the car

Remove four bumper retaining screws and bumper.

Remove four front screws from top chassis plate.

Detach track rods, roll bar links and remove front suspension.

Remove A324 self-tap screws from front transmission housing.

Remove top screw from T101 servo mounting post to allow chassis and top plate to be flexed apart.

T055 front transmission housing can be rotated to allow chassis and top belt to be unhooked and transmission assembly removed.

Reverse above procedure to refit.

- 9 Refer to 'CAT' Instruction Manual for belt tension adjustment.
- 10 Front-differential adjustment is similar to the integrator. Lock the T084 axle using a small screwdriver in the slot in the head and rotate the other wheel; clockwise to tighten and vice versa. Correct tension is achieved when wheels just skid as the car is pulled backwards by holding the rear wheels. Excessive tension is unnecessary and will lead to stiff differential action.

FRONT DIFFERENTIAL ASSEMBLY - PARTS LIST

Bag No.	Spares No.	Part No.	Description	No. Off
T526	T526		Front Differential Assembly	2
	T118	T118	Washer Carrier - Large	2
	T532	T532	Ball Race 8 x 12 F	2
	T084	T084	Rear Axle	1
	T055	T055	Front Transmission Housing	2
	T617	T033	Centre Pulley Rear	1
	T612	T031	Rear Hub	2
	A520	A520	Thrust Race	1
	T620	A324	Self Tap No. 4 x 1/2 Pan Hd.	2
	T618	T080	Flange	2
	T635		Front Differential Repair Kit	
	A220		Thrust Washer 3/8 x 13/16 x 1/32	2
	A500		Steel Ball 3.0mm diameter	8
	A154		Disc Spring 1/8	2
	A051		Nut M3 Nyloc	1

CROSS SECTION THROUGH DIFFERENTIAL

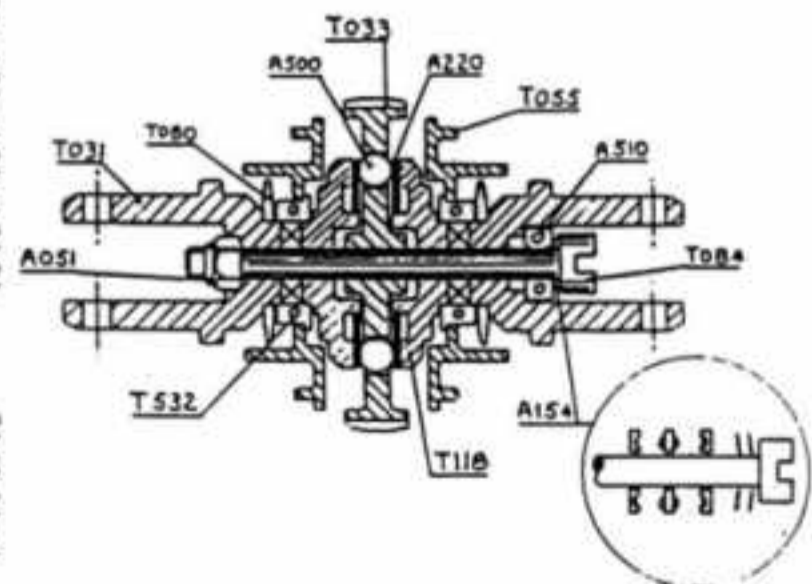

TRACK SETTINGS

In general the car should understeer - this means the front wheels slide more than the rear wheels during cornering. You can get this by cutting the spikes of the front tyres down. It helps to have two or three sets of front tyres with different levels of spikes to test for the best option.

Run the lowest ride height that track conditions will allow - a low car always corners better than a high car.

Use the softest damper settings that stop the wheels from bouncing. It is very easy to over damp the car and cause bouncing at speed.

Your 'CAT' is a thoroughbred racer and therefore has various adjustments to enable you to get optimum performance over a wide range of track conditions.

The following chart lists these features and the columns show examples of settings for particular conditions. Column (1) will provide safe, predictable handling for general testing and demonstrating. Other columns illustrate race winning specifications for the circuits shown.

It is an enormous help to return to a circuit with the car well set up right from the first lap.

1	Circuit Type	Standard Test Spec	Worlds End Mainly grass Very bumpy	Chesham Long Track Fast, grassy Tarmac bends	Southend Wide Ranging Conditions	Remney Fast & Loose
2	Rear anti roll bar dia Std 01.8	Std	Std	Std	Std	
3	Rear anti lower fixing	2nd hole out	3rd hole out	3rd hole out	3rd hole out	
4	Rear damp lower fixing	3rd hole out	3rd hole out	3rd hole out	2nd hole out	4th hole out
5	Rear damp Oil type	10 W 40	EP90	10 W 40	10 W 40	3 in 1
6	Rear damp Piston	Std	Doubled orifice	Std	Std	Std yellow
7	Rear damp spacers under piston	Nil	Nil	Nil	Nil	12mm Silicon Tube
8	Rear damp spring	Std	Std	T133 .045 x 11 x 2.5	T133 .045 x 11 x 2.5	Assoc Silver
9	Rear damp spring spacers	Nil	Nil	4mm	10mm	3mm
10	Rear Lower wishbone offset	Rearward	Forward	Forward	Forward	Forward
11	Rear bump steer	Nil	Nil	Nil	Nil	Nil
12	Rear toe in	Nil	Nil	Nil	Nil	Nil
13	Front anti roll bar dia Std 01.6	Std	Std	Std	Std	
14	Front anti lower fixing	3rd hole out	3rd hole out	4th hole out	4th hole out	
15	Front Damper lower fixing	1st hole out	1st hole out	1st hole out	1st hole out	2nd hole out
16	Front Damper Oil type	10 W 40	EP90	10 W 40	10 W 40	3 in 1
17	Front Damper Piston	Std	Doubled orifice	Std	Std	Std yellow
18	Front Damper Spacers under piston	4mm	4mm	Nil	Nil	4mm Silicon Tube
19	Front Damper Spring	Std	T132 .045 x 8 x 1.5	T132 .045 x 8 x 1.5	T132 .045 x 8 x 1.5	Assoc Silver
20	Front Damper Spring spacers		4mm	4mm	4mm	12mm
21	Front lower wishbone offset	Forward	Forward	Forward	Forward	Rearward
22	Front bump Steer	Nil	Nil	Nil	Nil	Nil
23	Front toe in	Nil	Nil	Nil	Nil	Nil
24	Front Tyres	Schumacher spikes cut to half height	Std Schumacher spikes	Schumacher spikes outer row removed	Schumacher spikes outer row removed	Schumacher T655
25	Rear Tyres	Std Schumacher spikes	Std Schumacher spikes	Std Schumacher spikes	Schumacher Synthetic Spikes 570 Part No. T 525	Schumacher T651
26	Front Drive (Integrator No Drive = 0% Full Drive = 100%)	50%	50%	50%	100%	100%
27	Motor Type	27 T Std	18 T Std	18 T Std	18 Std	Reedy Silver Dot
28	Gear Ratio	16/58	13/58	15/60	14/60	17/58
29	Batteries	Sanyo SCR	Schumacher Custom Pack SCR	Schumacher Custom Pack SCR	Schumacher Custom Pack SCR	Custom S-C-R
30	Total running time	6 min	5½ min		7 min	5½ min
31	No of laps		16	17	15	16
32	Race duration	5 min	5 min	5 min	5 min	5 min
33	Weather conditions	Fine & dry	Fine & dry	Fine & dry	Fine & dry	Fine
34	Date	21.9.86	21.9.86	28.9.86	5.10.86	12.4.86
35			1st & TQ	1st & TQ	1st & TQ	1st & TQ
36	Other				Wing Back 25mm	T 642 XL L. W. B. Conversion
37						T643 Rear Suspension
38						T640 oneway drive shaft
						T526 Front diff.