

# Schumacher

# 2000

THE NEXT GENERATION

ISSUE 3



## INSTRUCTION MANUAL

CHASSIS	1
REAR SUSPENSION	2
DIFFERENTIAL	3-4
TRANSMISSION	5-6
DRIVESHAFTS	7
FRONT SUSPENSION	8-12
SHOCK ABSORBERS	13-15
WHEELS & TYRES	16
BODYSHELL	17
BUMPER & UNDERTRAY	18
REAR WING & ARIEL	19
FITTING ELECTRICS	20
SERVICING	21
TRACK SETTINGS	22-25

**SCHUMACHER RACING PRODUCTS LTD**  
 71 - 73 Tenter Rd  
 Moulton Park  
 Northampton  
 NN3 6AX

*Due to our policy of continuous development the exact specification of the kit may vary.*  
**MISSING OR DEFECTIVE PARTS**  
 In the event of problems with your new kit you should contact the manufacturer where purchased, quoting part number, bag number and bag number for both the bag and the kit.

### IMPORTANT SAFETY NOTES

1. This product is not suitable for children under 14 years of age unless supervised by an adult.
2. Select an area for assembly that is away from reach of small children. The parts are small and can be swallowed by children causing choking and possible internal injuries.
3. Shock fluids, grease and adhesives should be kept out of childrens reach. They are not toxic, but were not intended for human consumption.
4. Exercise care when using any hand tools, sharp instruments and power tools during construction.
5. Carefully read all manufacturers warnings and cautions for any glues or paints that may be used for assembly purposes.



Places to put threadlock.  
(It will prevent the screws and nuts vibrating loose.)



Points where grease should be applied. (It will reduce friction and assure smooth movement.)



Points where oil should be applied (Light machine oil, 3 in 1 or similar.)

*Do not use excessive force when tightening the self-tapping screws, or you may strip the thread in the plastic. It is recommended to stop tightening it when the threaded part on the screw goes into the plastic part and you feel some resistance from the tightening.*

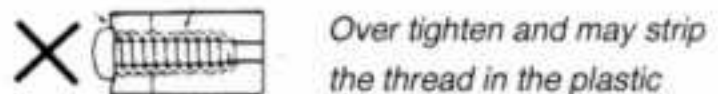
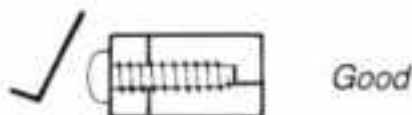

### ADDITIONAL ITEMS REQUIRED

TRANSMITTER

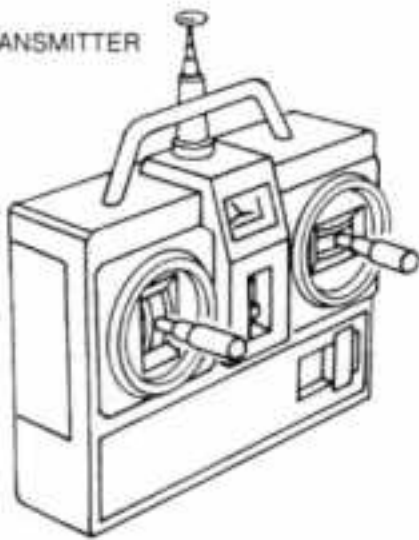

RECEIVER

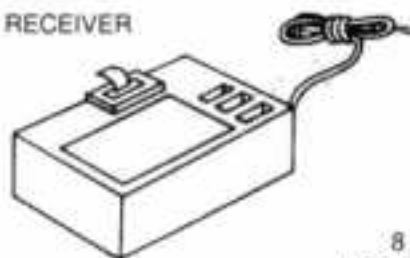

MOTOR

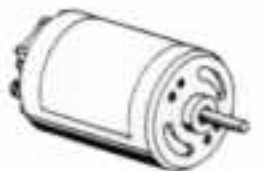

STEERING SERVO

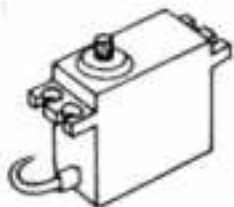

8 PEN CELLS  
(FOR TRANSMITTER)



SPEED CONTROLLER



NICADS SADDLE PACK

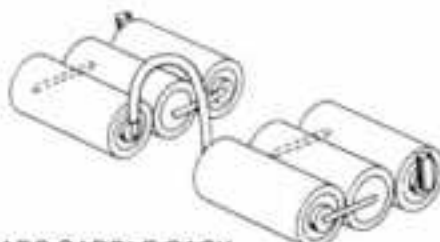

NICAD CHARGER

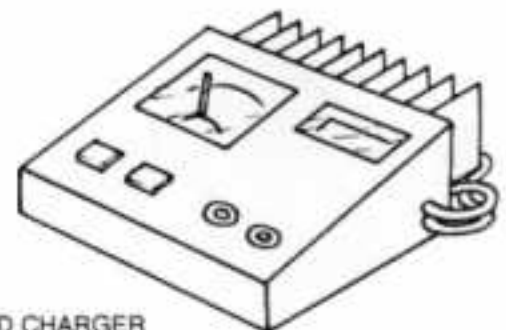

**FOR BEST PERFORMANCE, IT IS VERY IMPORTANT THAT GREAT CARE IS TAKEN TO ENSURE THE FREE MOVEMENT OF ALL PARTS.**

### TOOLS REQUIRED

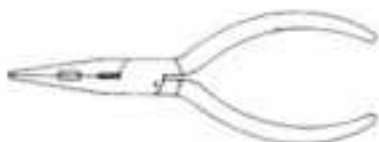

7.0 AF 5.5 AF



### MATERIALS REQUIRED

Threadlock  
Light oil for shock absorbers  
Polycarbonate paint for bodyshell  
Grease

**RULER** INCHES & MILLIMETRES

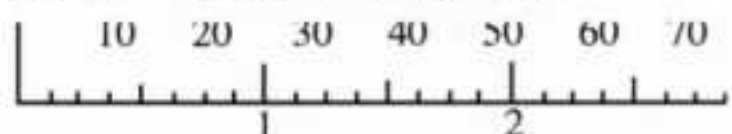

1

CHAMFER EDGES OF NICAD SLOTS AND REMOVE ANY PIPS USING A FILE

**WARNING: MOTOR CLEANING SOLVENTS WILL DAMAGE THE W.F.E. COMPONENTS. ALWAYS REMOVE MOTOR BEFORE DOING ANY MAINTAINANCE**

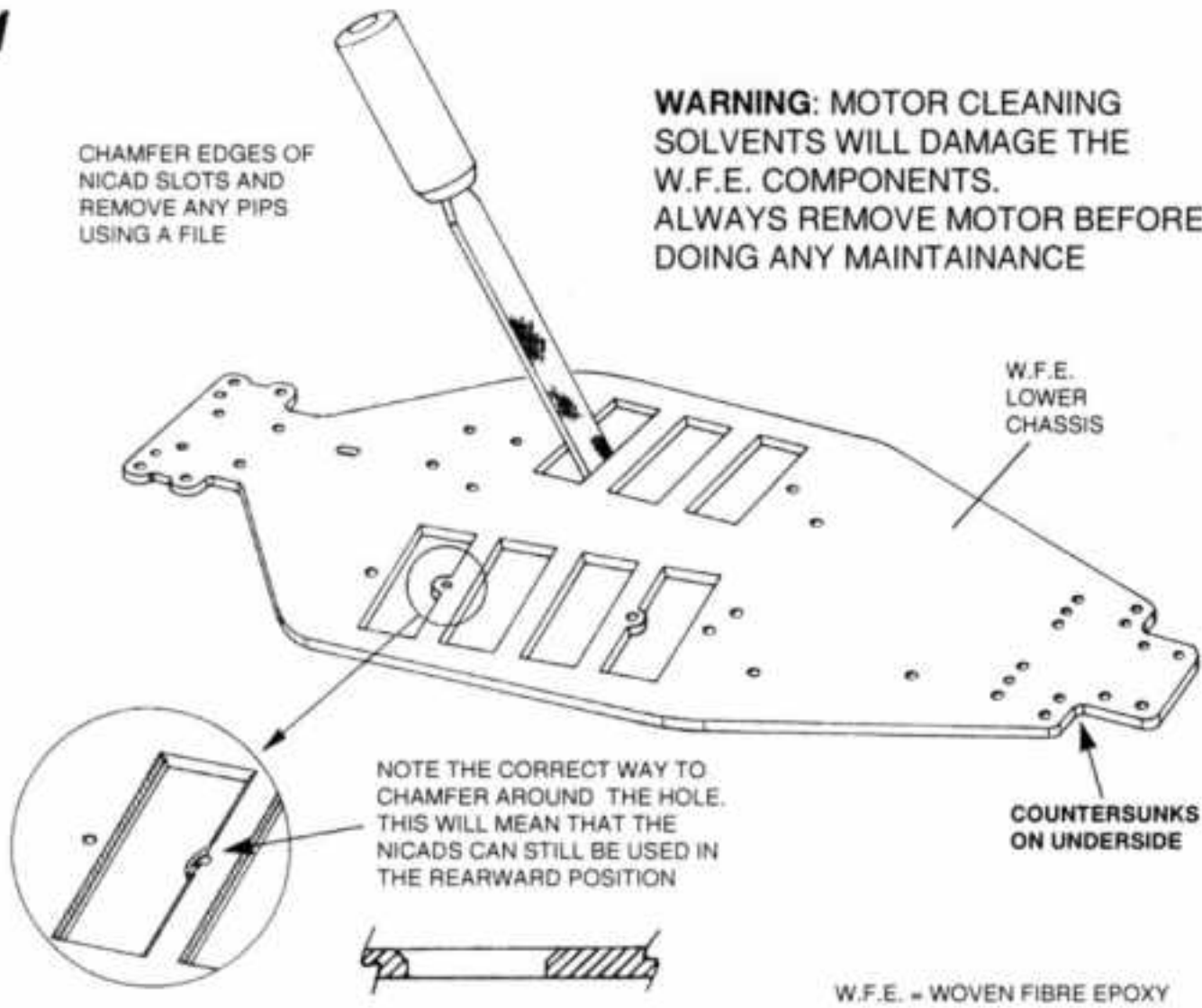

W.F.E. = WOVEN FIBRE EPOXY

**CHASSIS**

**HARDWARE**

A023  
M3x12mm  
CSK SCREW  
X2

A051 M3 NYLOC NUT  
X2

A225 M3  
STEEL WASHER  
X2

A333 No4x3/8"  
SELFTAP CSK SCREW  
X4

2

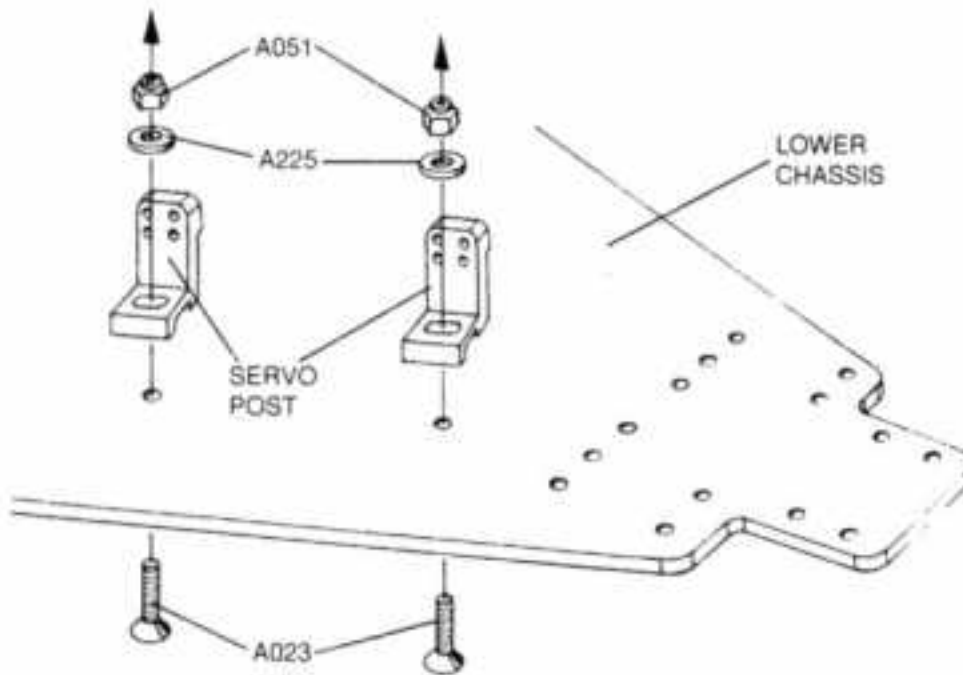

3

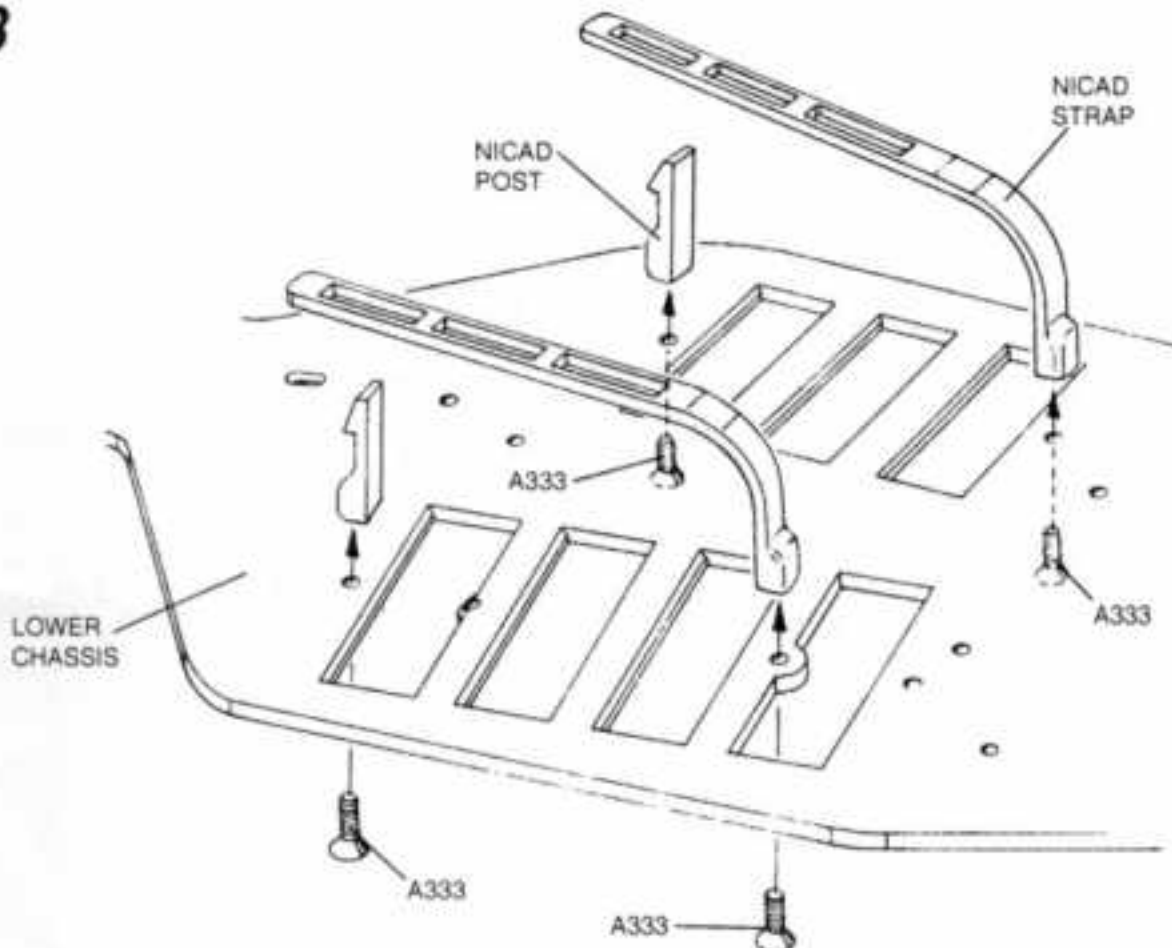

1

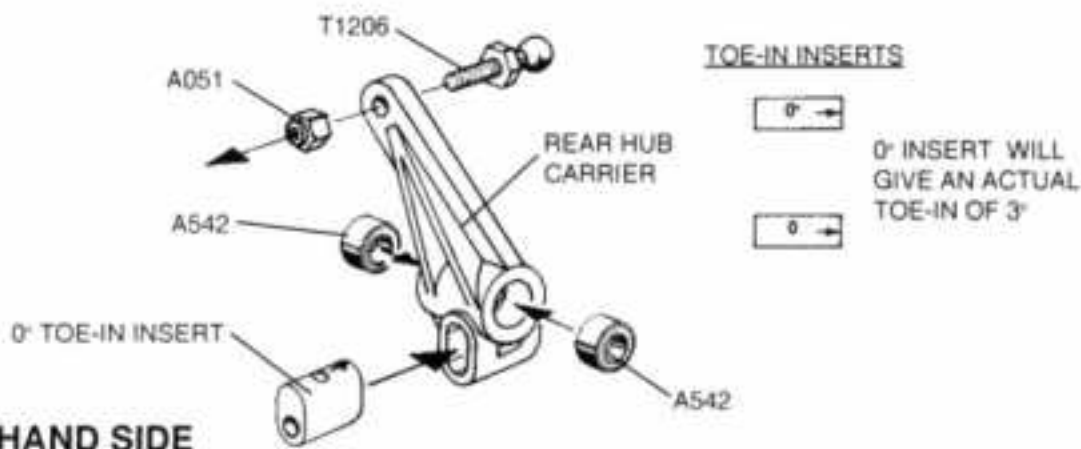

REPEAT FOR RIGHTHAND SIDE

2

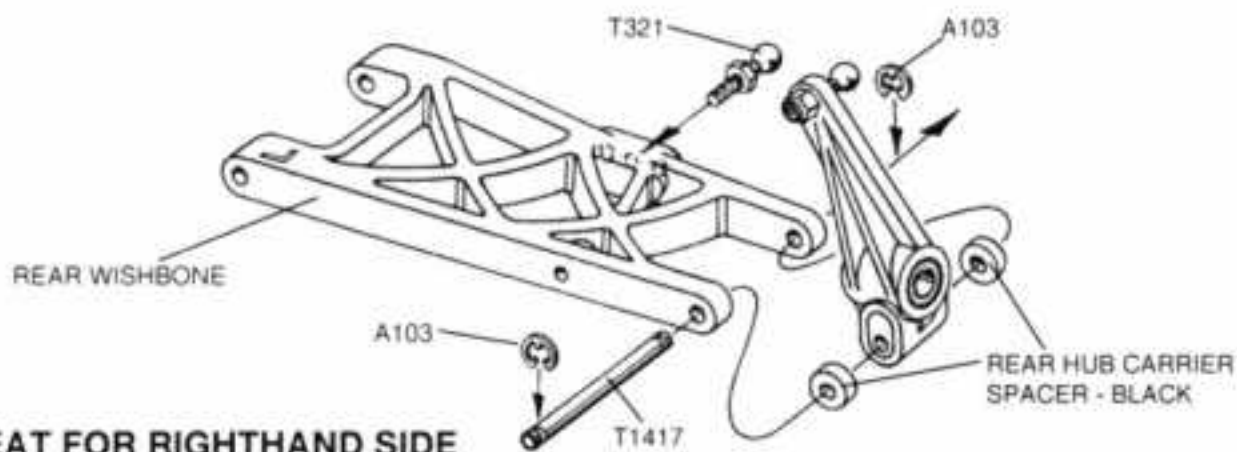

REPEAT FOR RIGHTHAND SIDE

3

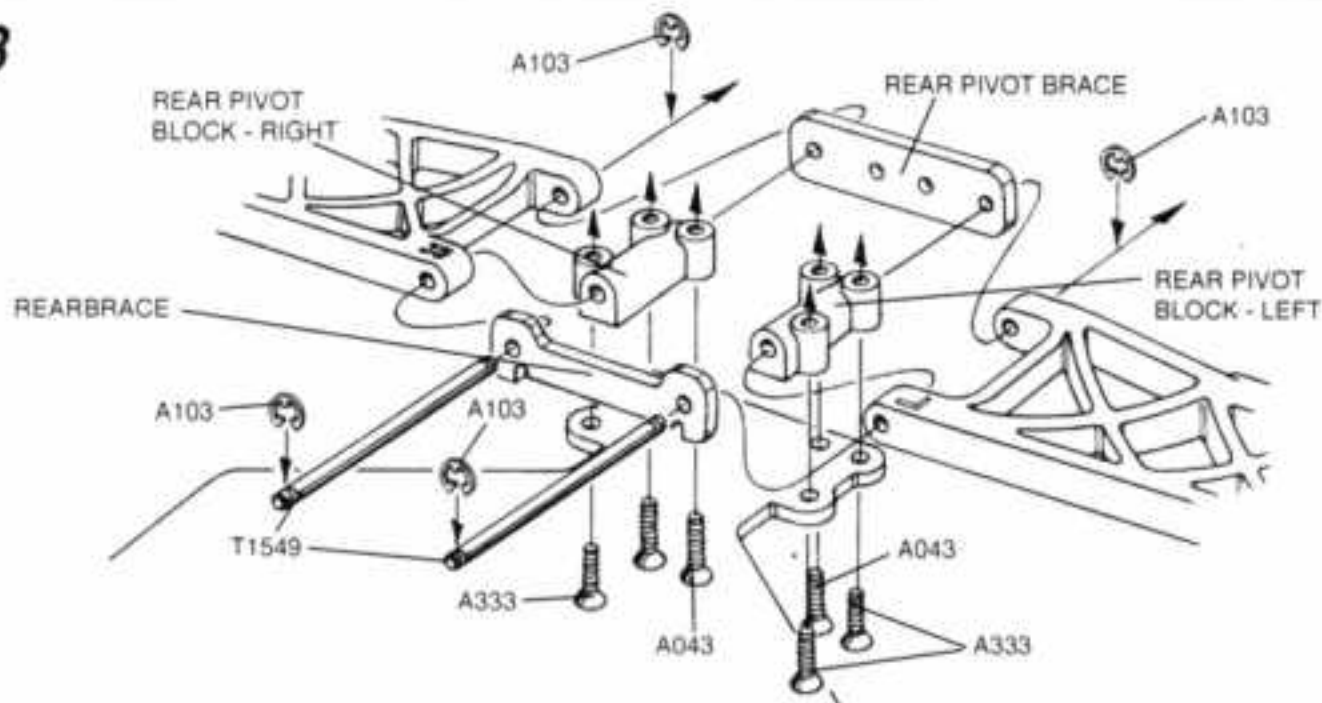

4

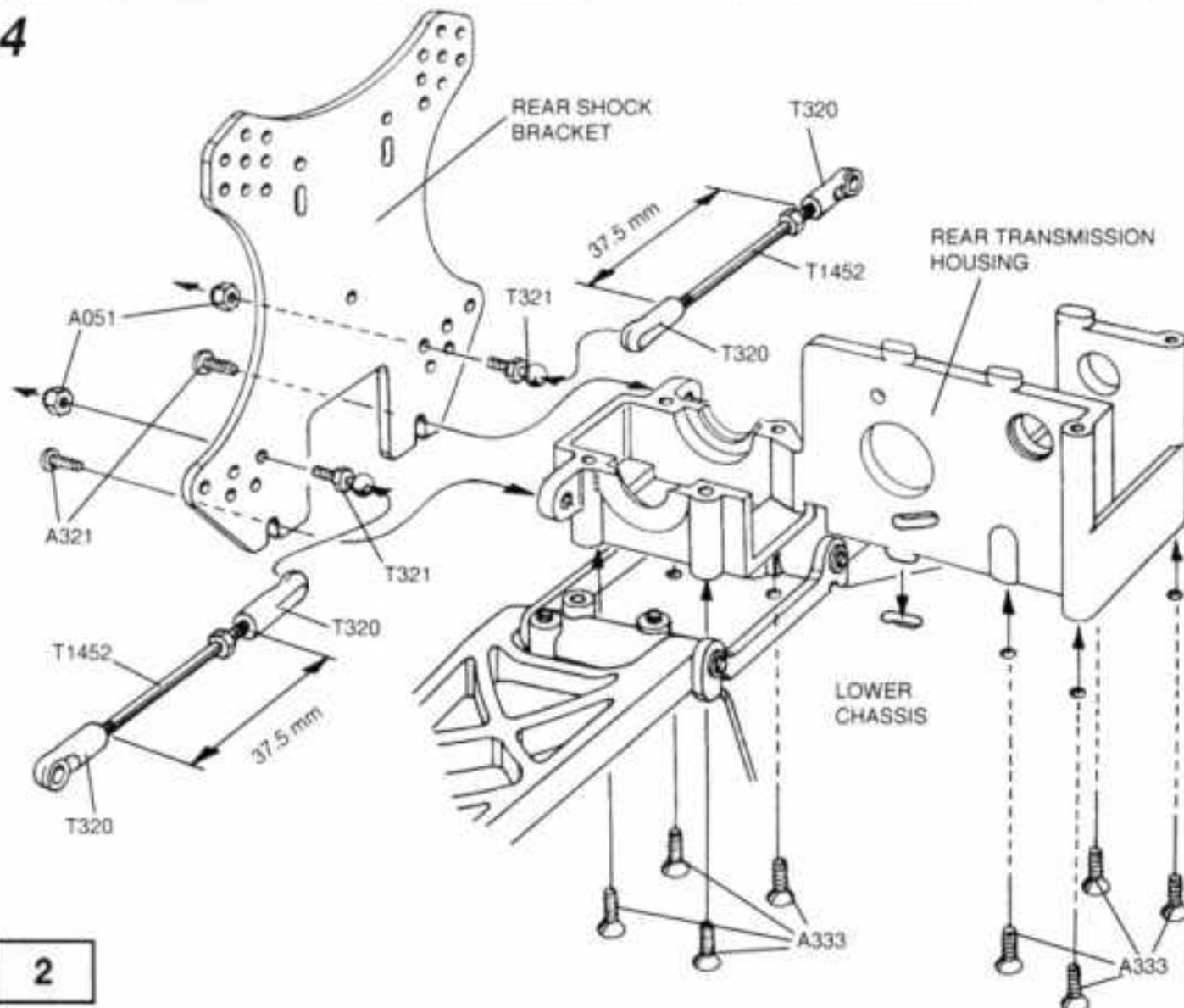

REAR SUSPENSION

HARDWARE

A051 M3 NYLOC NUT X4

T1206 BALL STUD LONG X2

A542 BEARING 5x9x3 X4

A103 'E' CLIP X8

T321 BALL STUD SHORT X4

T1417 REAR PIVOT PIN - OUTBOARD X2

A043 M3x8mm CSK SCREW X2

A333 No4x3/8" SELFTAP CSK SCREW X12

T1549 REAR PIVOT PIN - INBOARD X2

A321 No4x1/4" SELFTAP PANHD SCREW X2

T320 BALL JOINT SOCKET X4

T1452 TURNBUCKLE 53mm X2

**1** YOUR DIFFERENTIAL MAY BE PREASSEMBLED. IF SO USE STEPS 1 TO 14 FOR SERVICING.

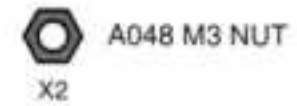
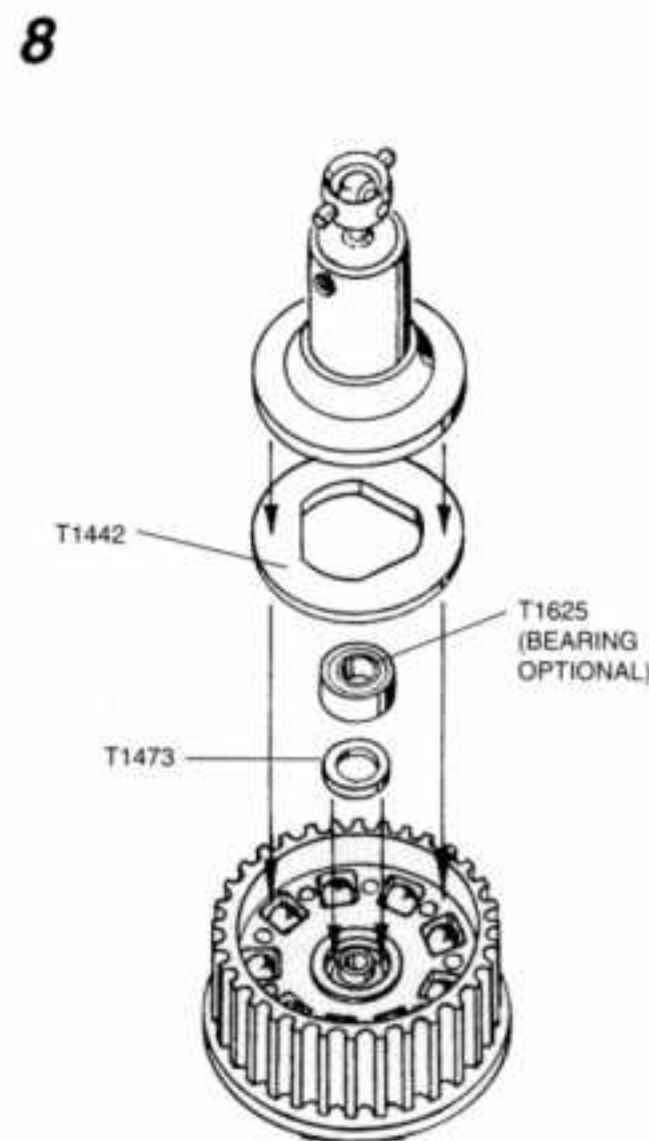
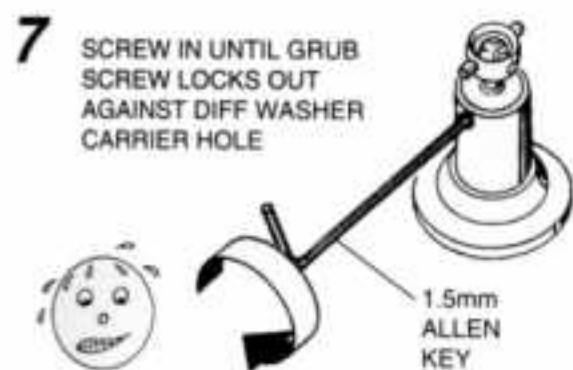
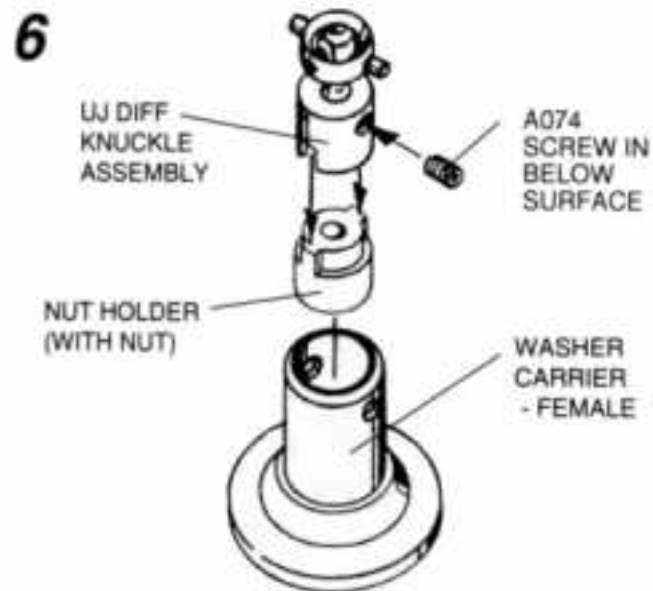
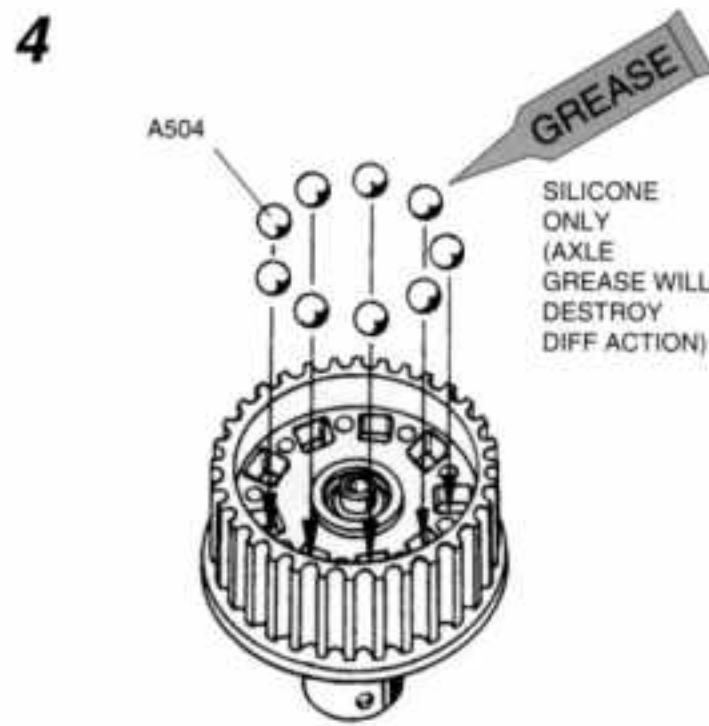
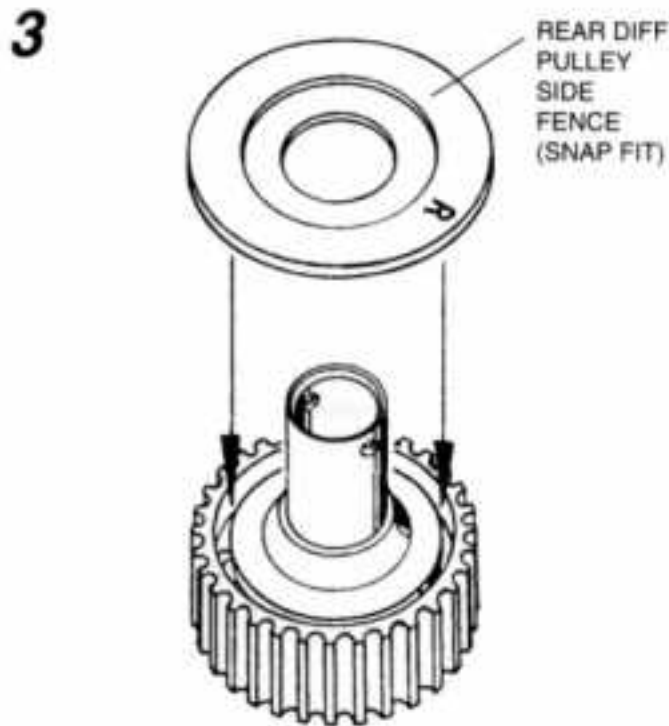
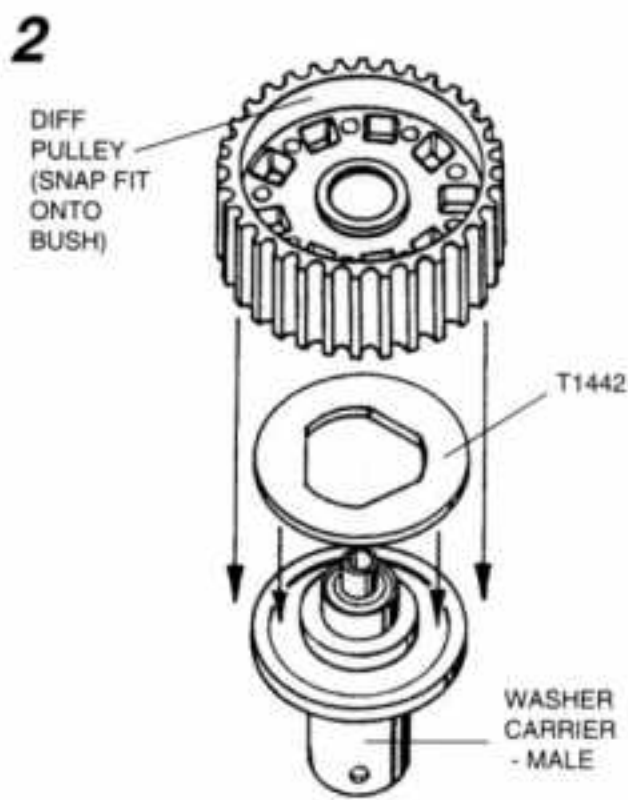
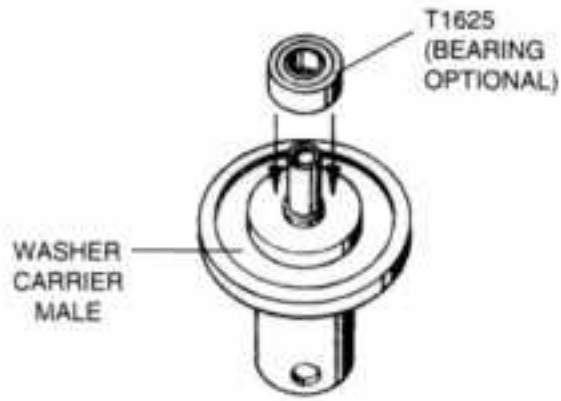

9

REAR DIFF PULLEY SIDE FENCE (SNAP FIT)

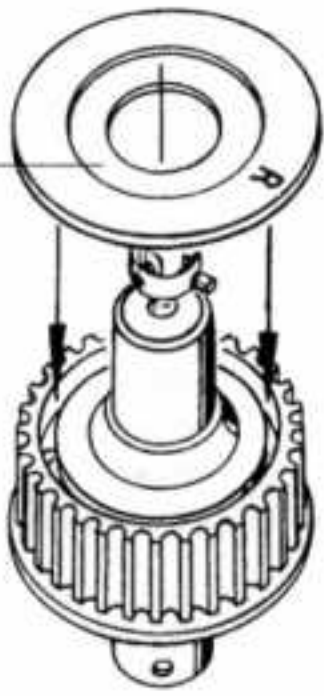

11



DIFF SCREW ASSEMBLY

13

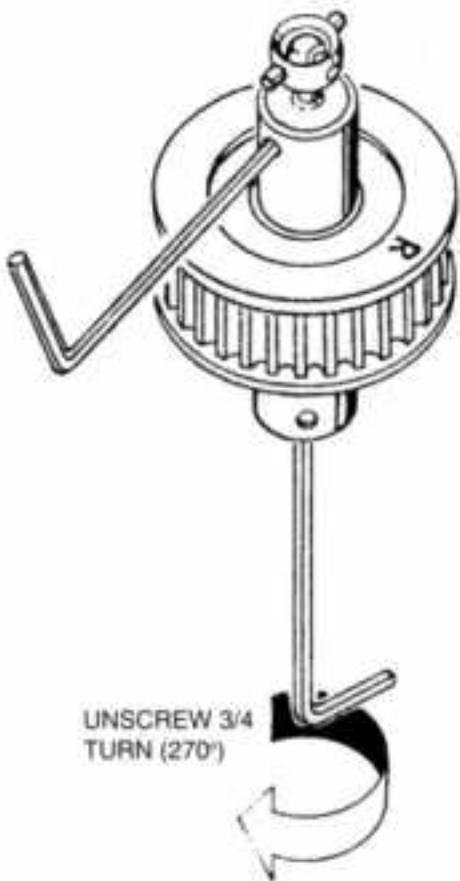

UNSCREW 3/4 TURN (270°)

NOTE CORRECT WAY TO ASSEMBLE DISC SPRINGS



U1507U (SPARES NUMBER)

NOTE: WASHER NEAREST SCREW HEAD IS SLIGHTLY SMALLER DIAMETER THAN WASHER NEXT TO DISC SPRINGS

A152

T1470

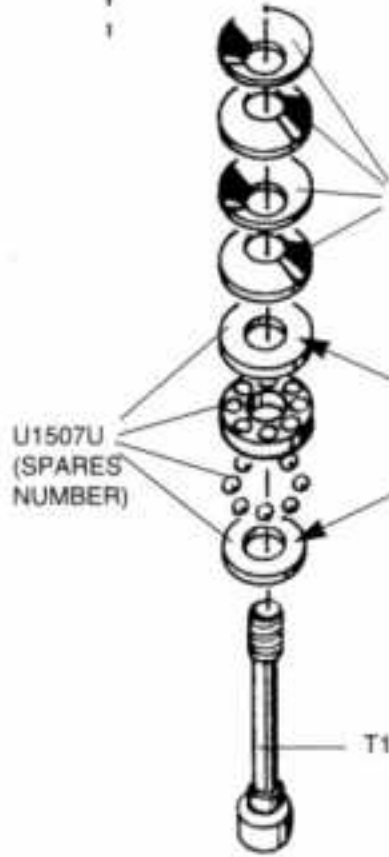

12

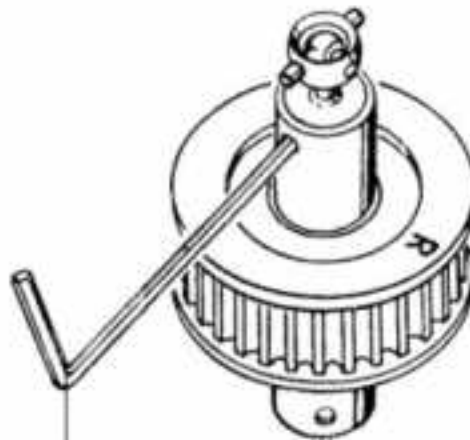

1.5mm ALLEN KEY (USE TO HOLD DIFF WHILE TIGHTENING)

2.5mm ALLEN KEY (USE THIS WAY ROUND ONLY TO PREVENT DAMAGING DIFF)

TIGHTEN FULLY

14

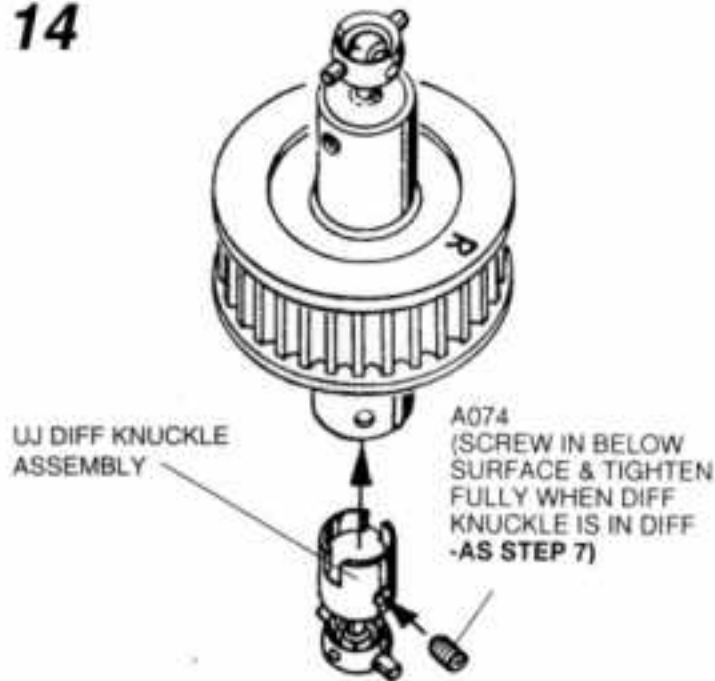

UJ DIFF KNUCKLE ASSEMBLY

A074 (SCREW IN BELOW SURFACE & TIGHTEN FULLY WHEN DIFF KNUCKLE IS IN DIFF -AS STEP 7)

Schumacher



DIFFERENTIALS

HARDWARE

A152 DISC SPRING X8

T1470 DIFF SCREW X2

UJ KNUCKLE ASSEMBLY X4

A074 M3 x 6mm GRUB SCREW X2

REPEAT ASSEMBLY FOR FRONT DIFF USING FRONT DIFF PULLEY FENCES (MARKED 'F')

1

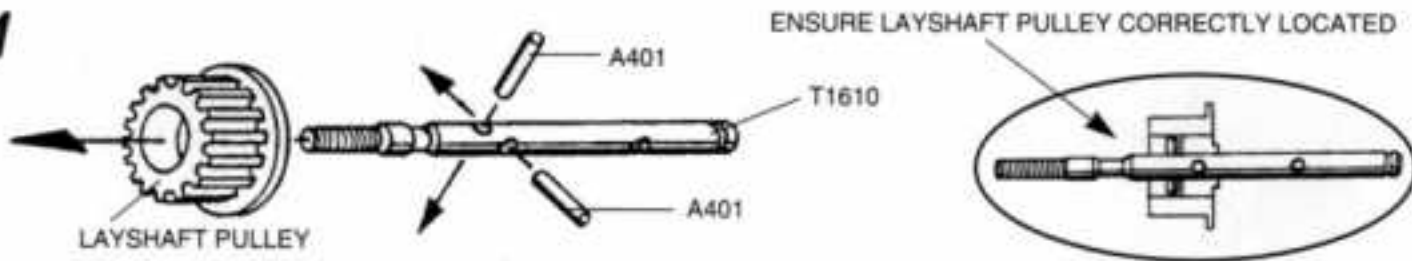

**TRANSMISSION**

**HARDWARE**

2

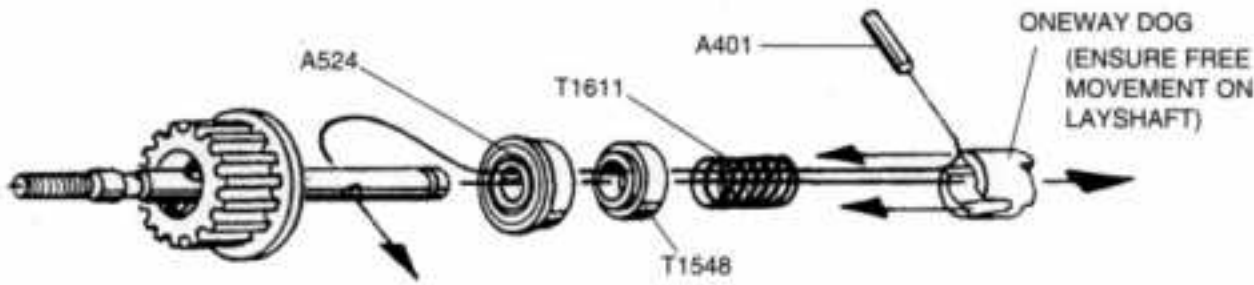

3

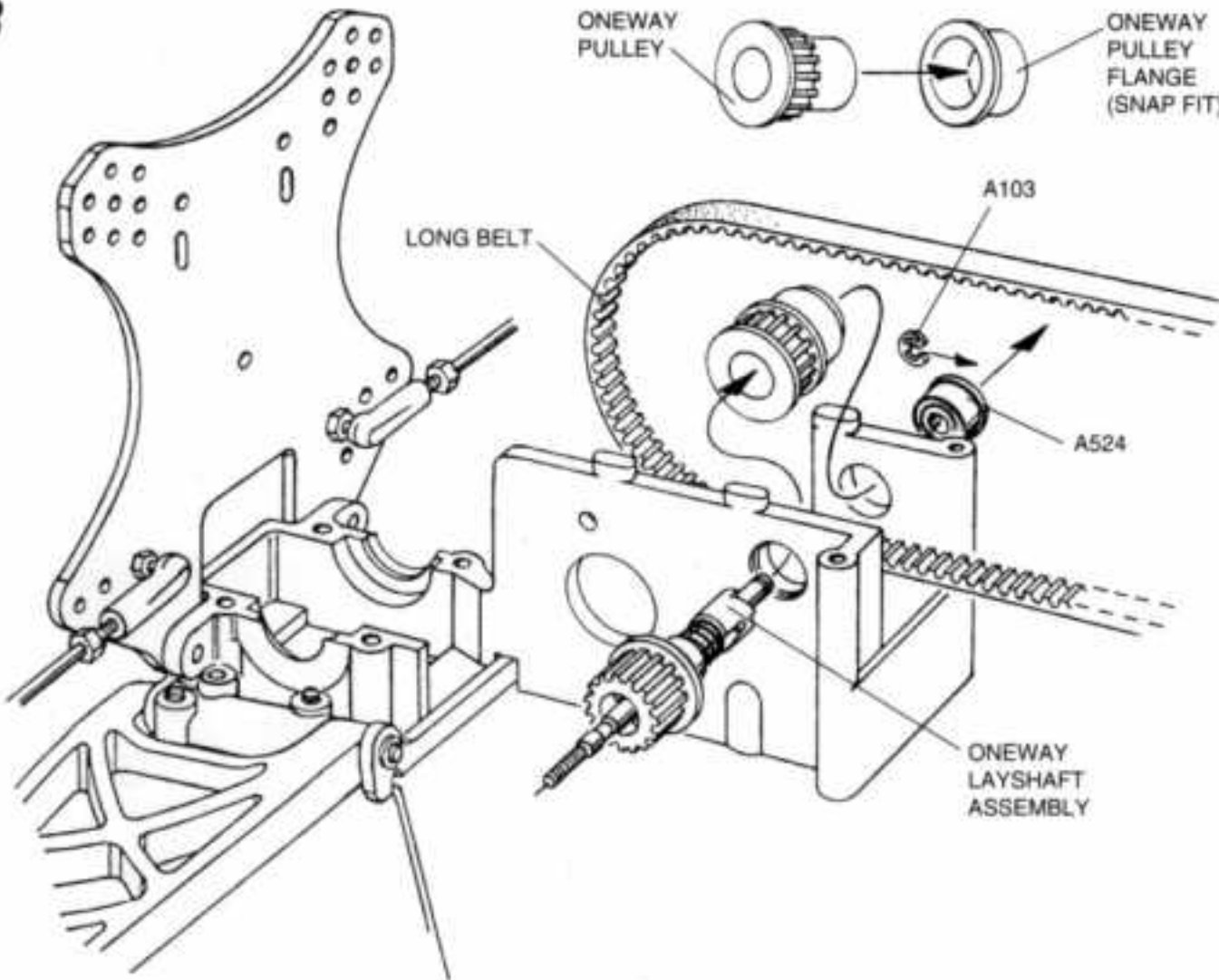

X1 T1610 SLIPPER LAYSHAFT 4WD



X1 T1611 LAYSHAFT ONEWAY SPRING



X1 T1548 LAYSHAFT SPACER



X3 A401 PIN 1.5mm DIA



X1 A103 'E' CLIP



X2 A524 8x4x3 FLANGED BEARING



X2 A529 BEARING 10x15x4

4

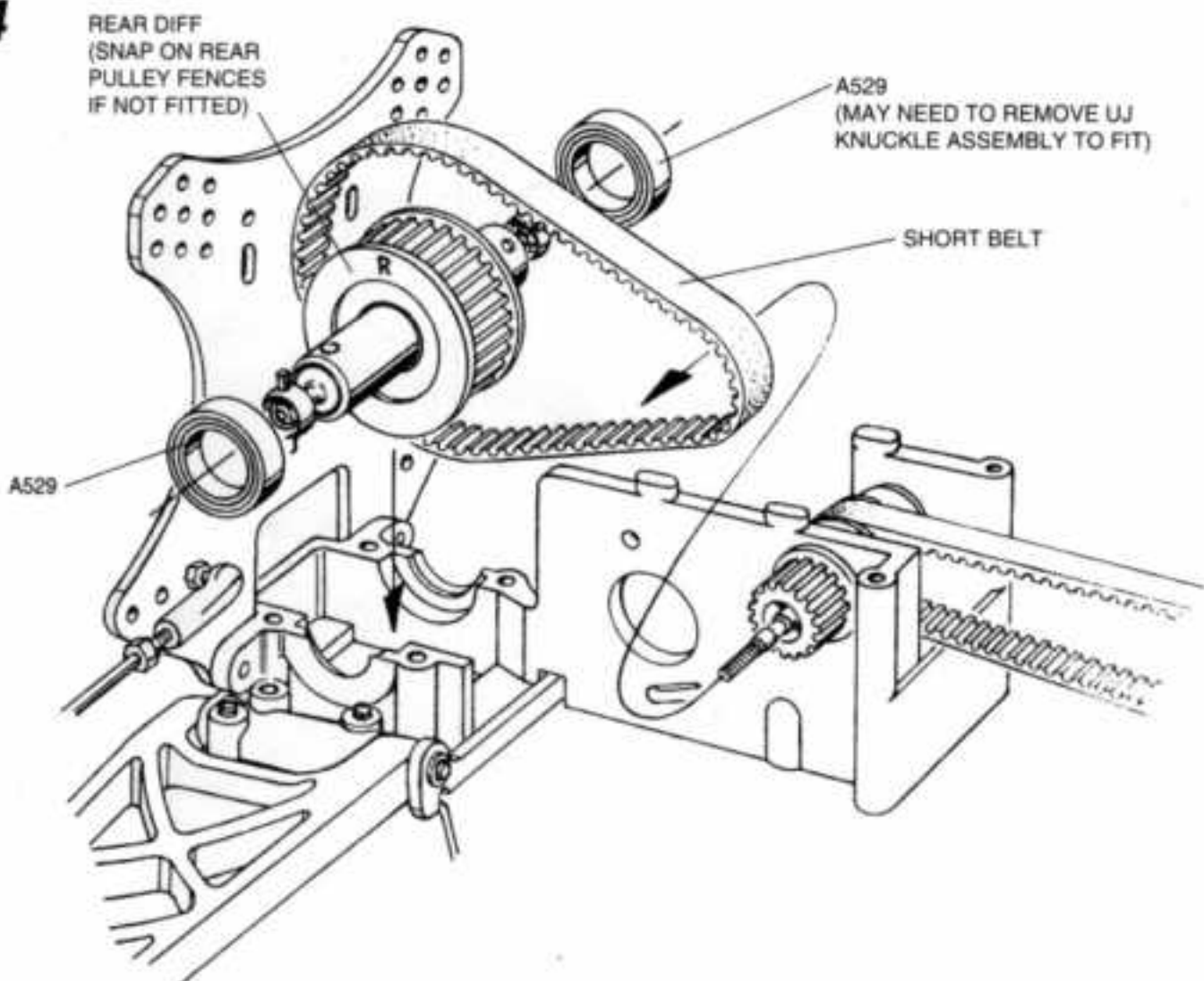



**TRANSMISSION**

**HARDWARE**

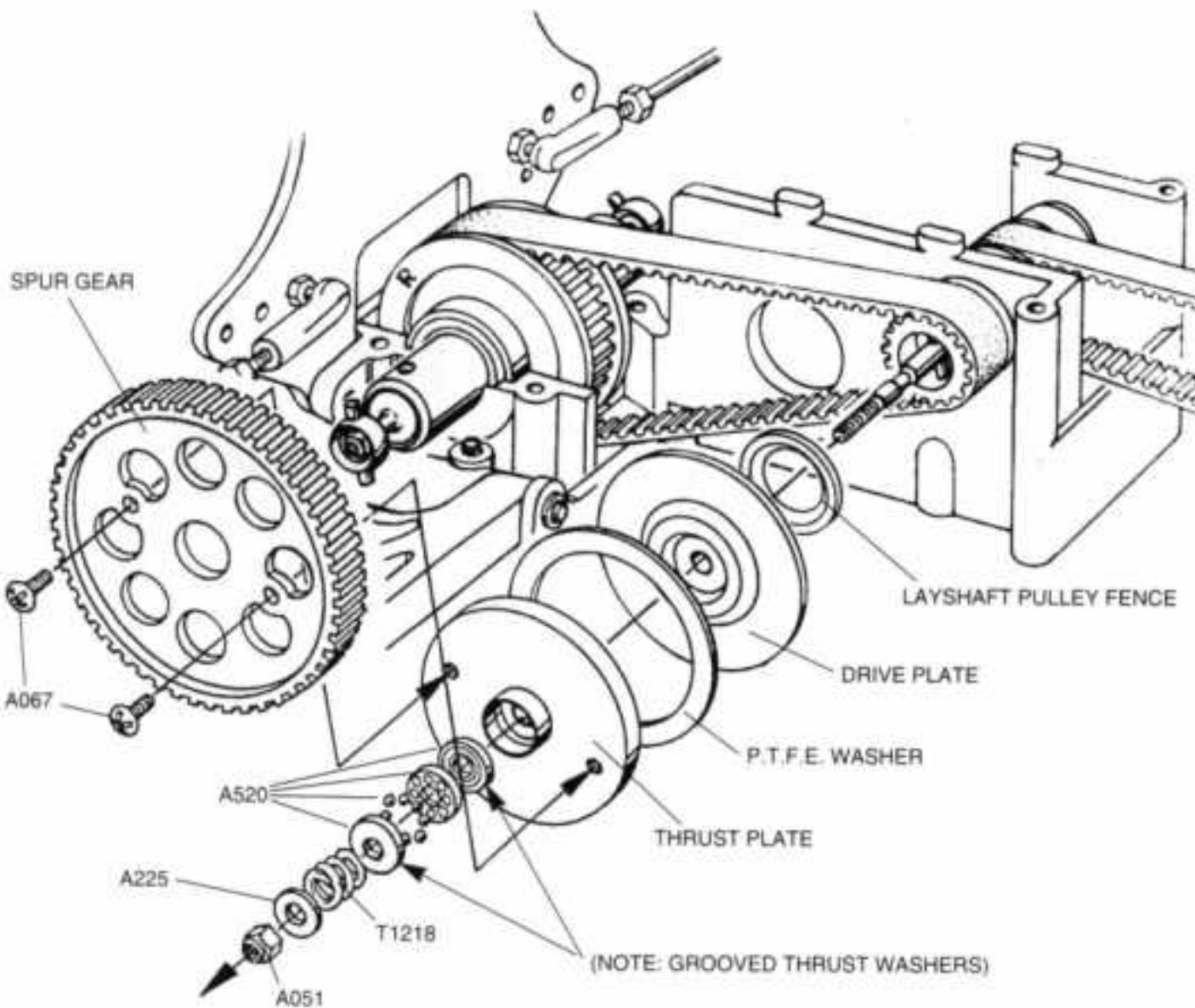

- X2
- X8 } A520 THRUST RACE ASSEMBLY
- X1

- A225 M3 STEEL WASHER
- X1

- T1218 SLIPPER CLUTCH SPRING
- X1

- A051 M3 NYLOC NUT
- X1

- A067 M3x4mm PANHD SCREW
- X2

- T1563 DRIVESHAFT WIRE
- X8

**6 CO-AXIAL DRIVESHAFTS**

X4

**ASSEMBLE ONE DRIVESHAFT AT A TIME**

REMOVE DIFF KNUCKLE ASSEMBLY FROM ONE SIDE OF DIFF. ASSEMBLE DRIVESHAFT THEN RE-ATTACH TO DIFF.

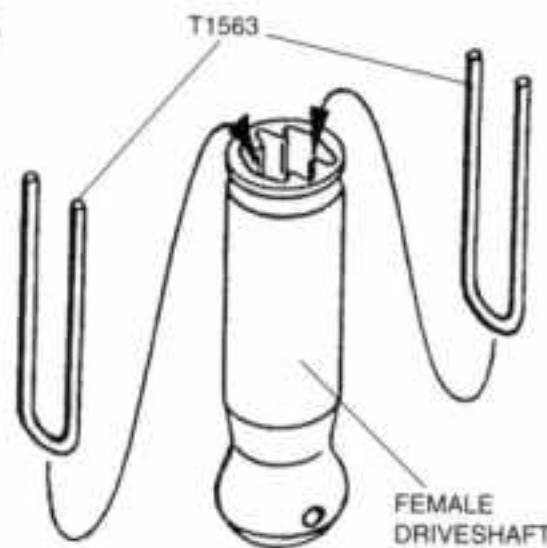

**7**

UNIVERSAL JOINT KNUCKLE ASSEMBLY

X4

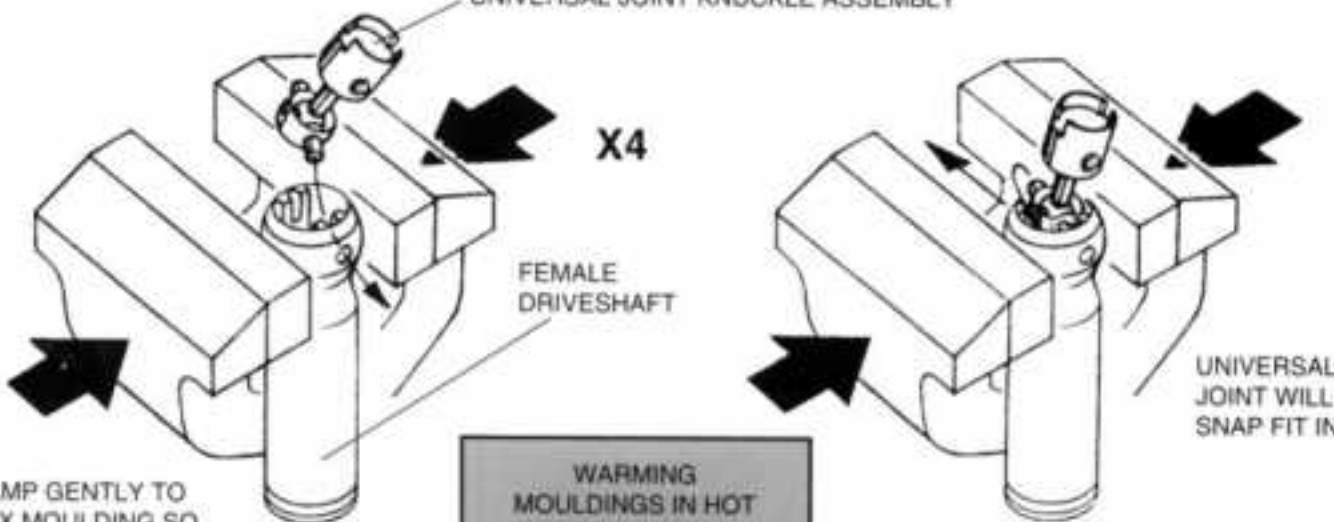

CLAMP GENTLY TO FLEX MOULDING SO CRUXIFORM JUST FITS IN. (USE SMALL VICE OR PLIERS)

WARMING MOULDINGS IN HOT WATER FIRST WILL EASE ASSEMBLY

8

LIVE AXLE BALL ASSEMBLY

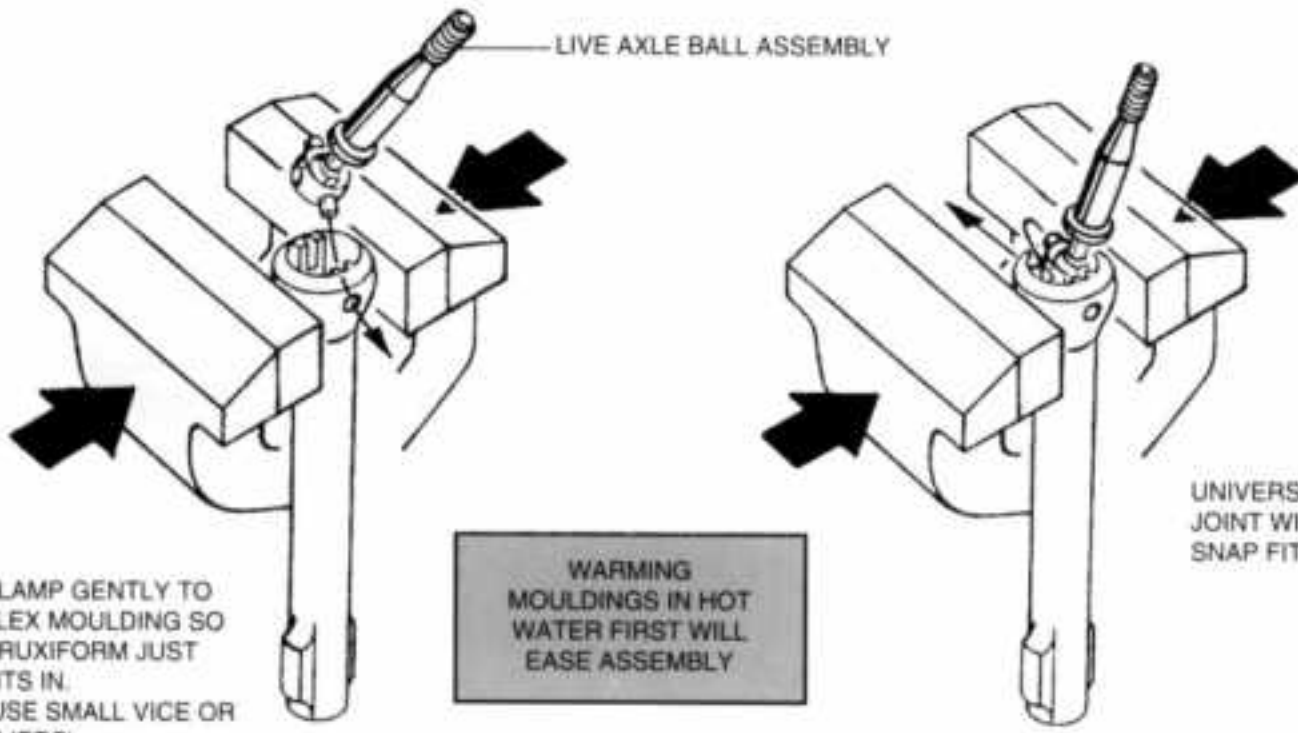

CLAMP GENTLY TO FLEX MOULDING SO CRUXIFORM JUST FITS IN.  
(USE SMALL VICE OR PLIERS)

WARMING MOULDINGS IN HOT WATER FIRST WILL EASE ASSEMBLY

UNIVERSAL JOINT WILL SNAP FIT IN

X4



DRIVESHAFTS

HARDWARE

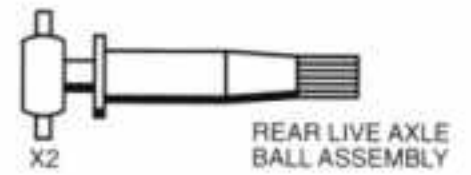
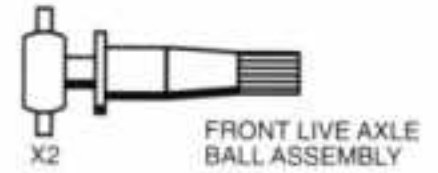

9

MALE DRIVESHAFT ASSEMBLY FOR REAR

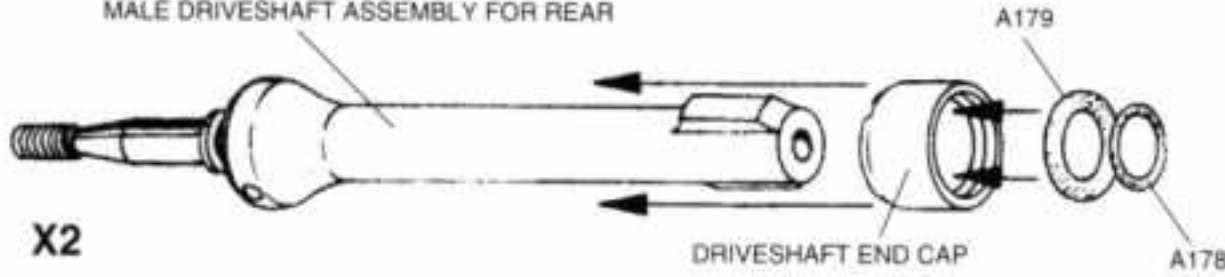

X2

DRIVESHAFT END CAP

A178

10

MALE DRIVESHAFT ASSEMBLY FOR REAR

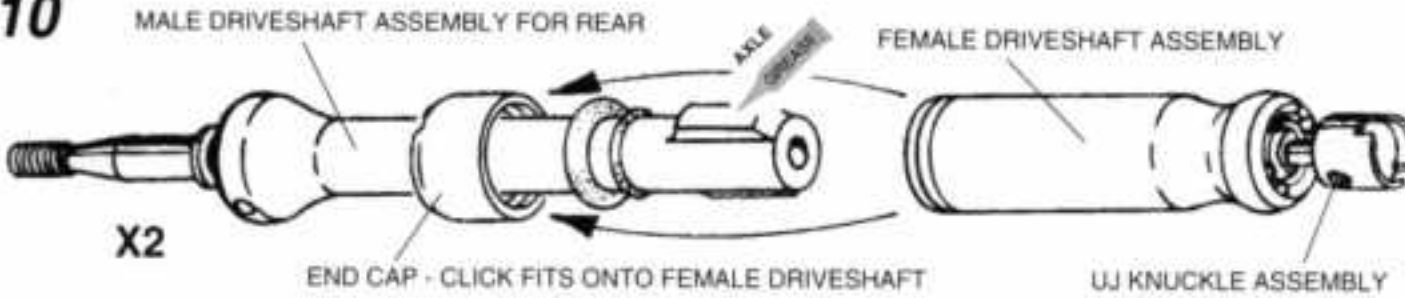

X2

END CAP - CLICK FITS ONTO FEMALE DRIVESHAFT

UJ KNUCKLE ASSEMBLY

11

FULLY TIGHTEN GRUB SCREW USING 1.5mm ALLEN KEY

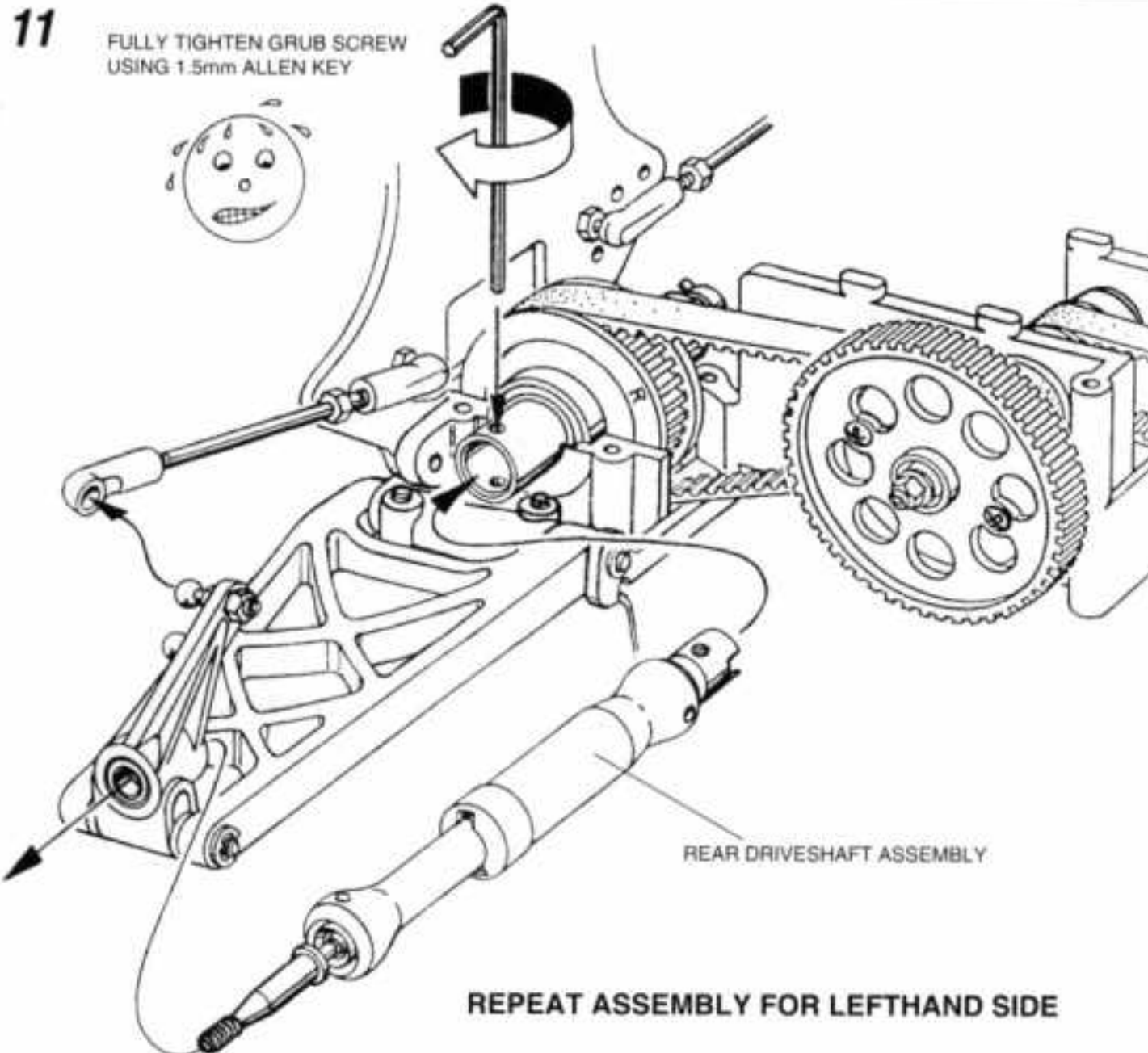

REAR DRIVESHAFT ASSEMBLY

REPEAT ASSEMBLY FOR LEFTHAND SIDE

NOTE:  
THE TWO FRONT DRIVESHAFTS HAVE TO BE ASSEMBLED LATER DURING CONSTRUCTION OF THE FRONT SUSPENSION

1

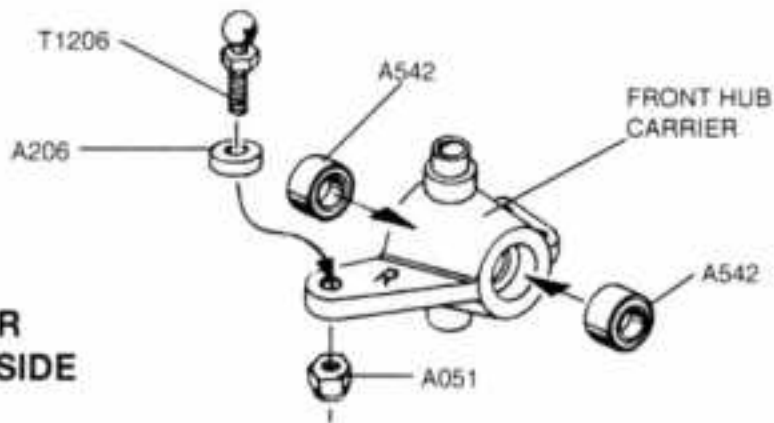

REPEAT FOR  
LEFTHAND SIDE



**FRONT SUSPENSION**

2

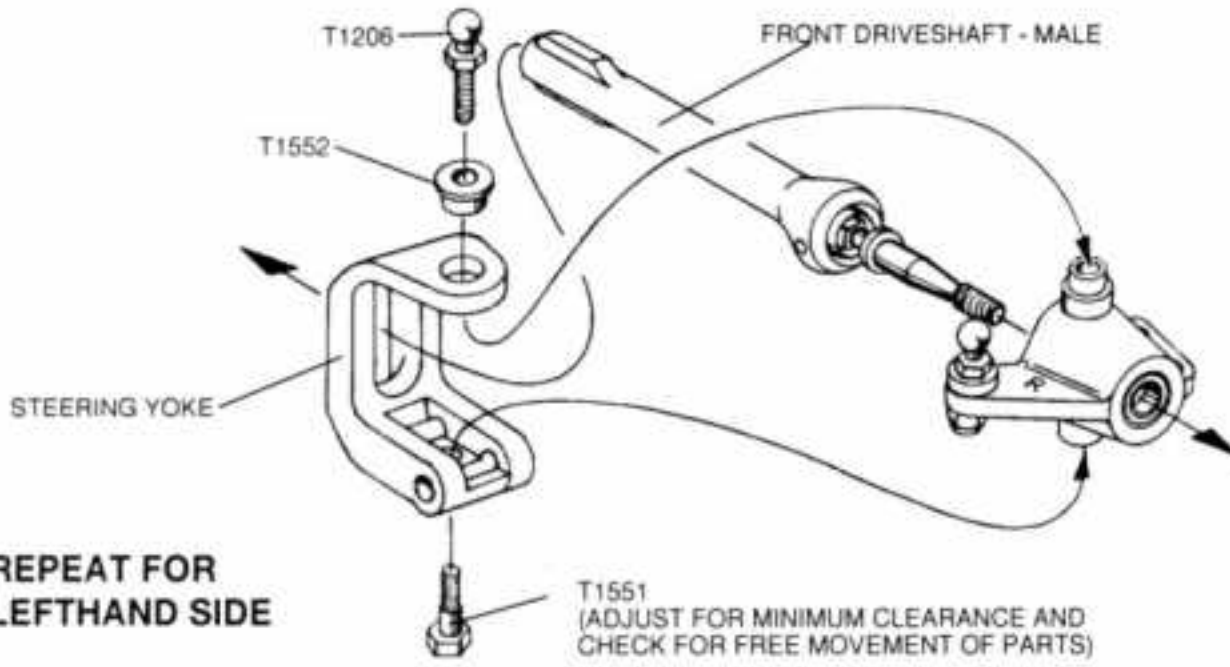

REPEAT FOR  
LEFTHAND SIDE

**HARDWARE**

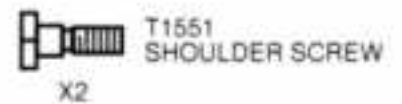
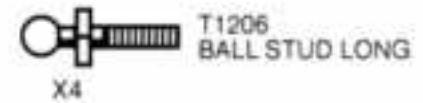

3

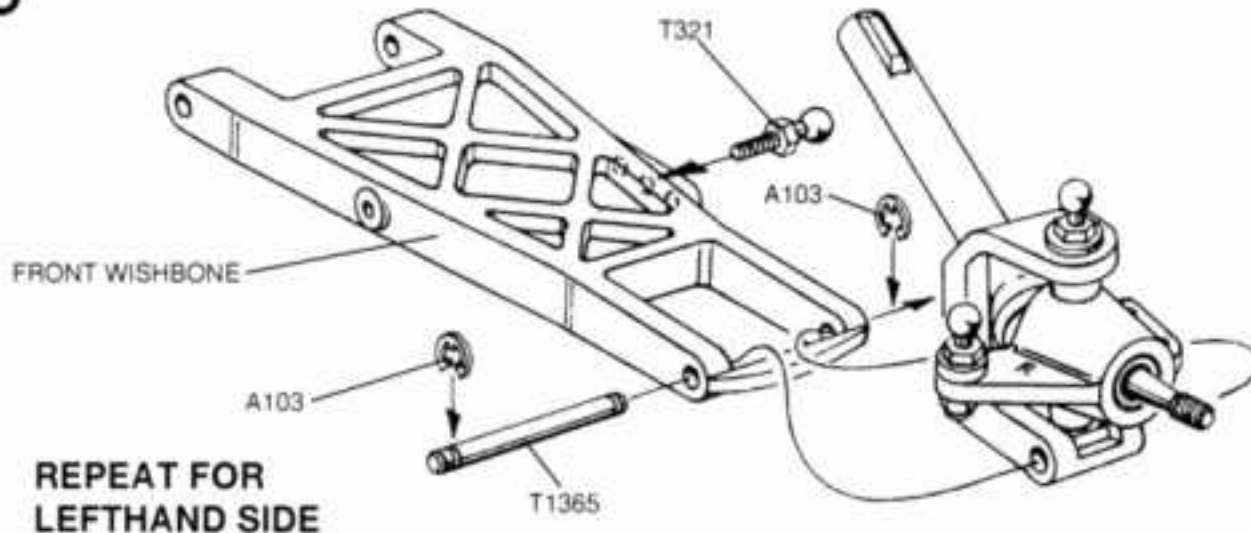

REPEAT FOR  
LEFTHAND SIDE

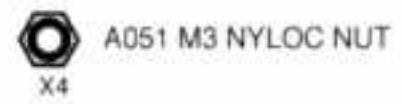
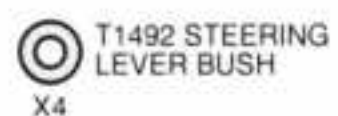

4

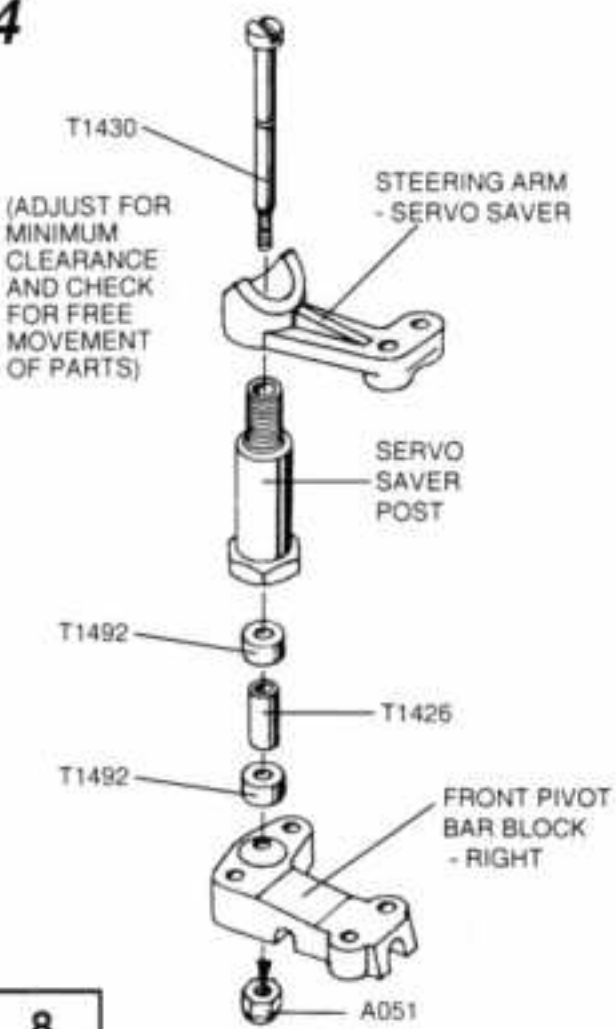

(ADJUST FOR  
MINIMUM  
CLEARANCE  
AND CHECK  
FOR FREE  
MOVEMENT  
OF PARTS)

5

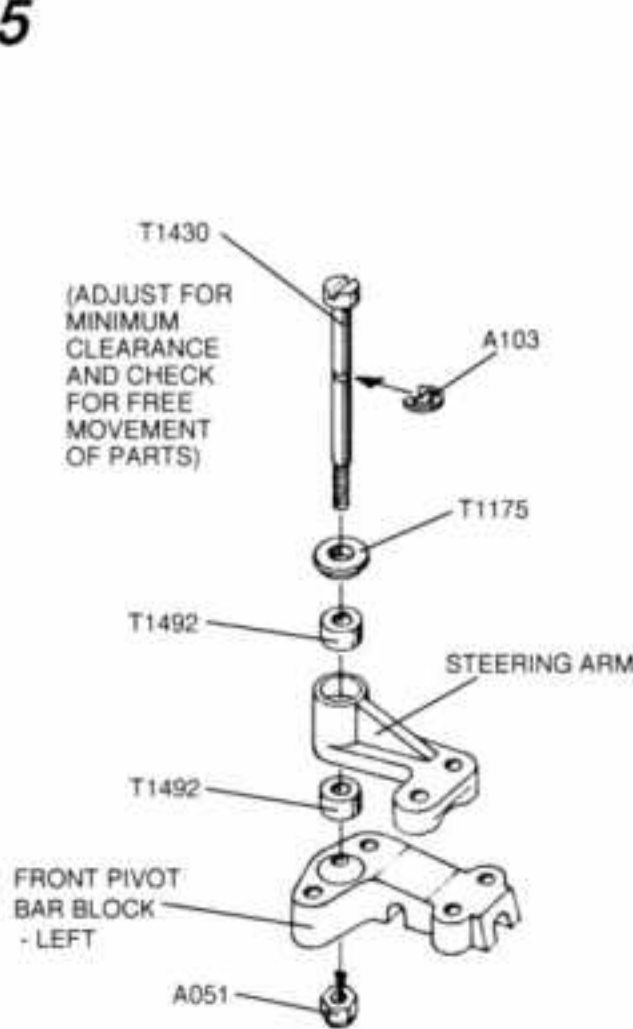

(ADJUST FOR  
MINIMUM  
CLEARANCE  
AND CHECK  
FOR FREE  
MOVEMENT  
OF PARTS)

6

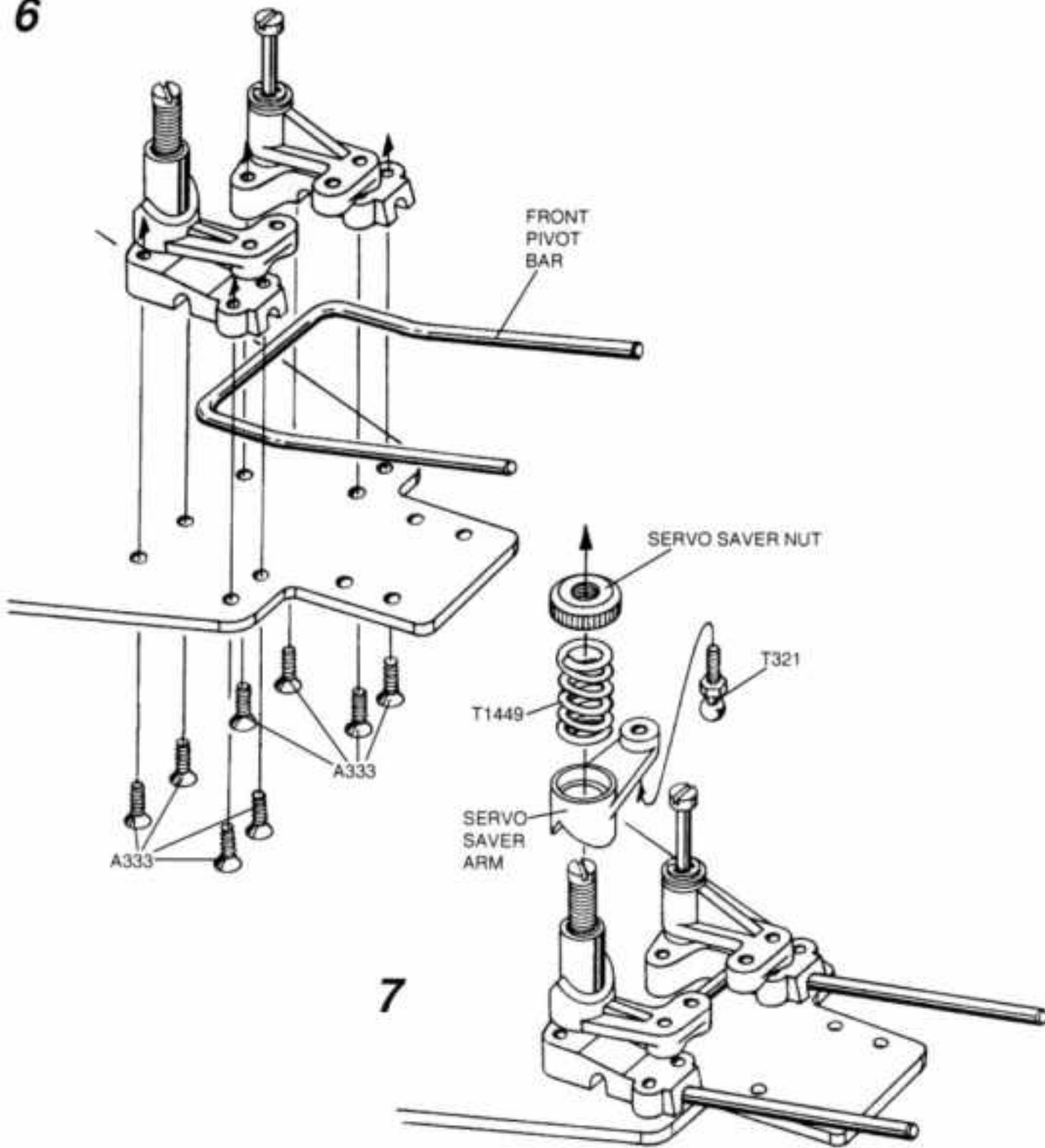

**FRONT SUSPENSION**

**HARDWARE**

 A333 No4x3/8" SELFTAP CSK SCREW  
X12

 T1449 SERVO SAVER  
X1

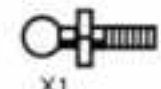
 T321 BALL STUD SHORT  
X1

 A529 BEARING 10x15x4  
X2

8

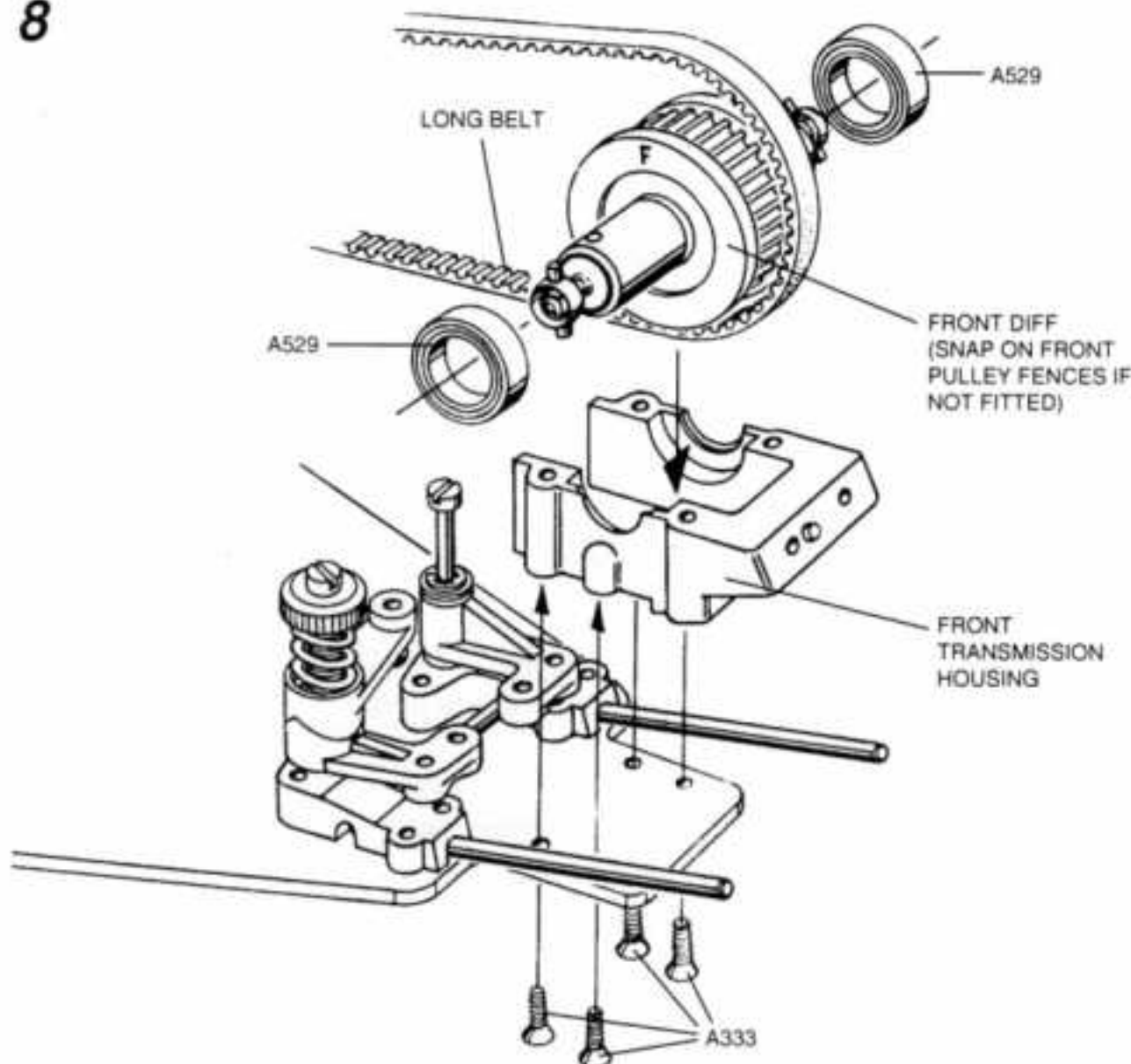

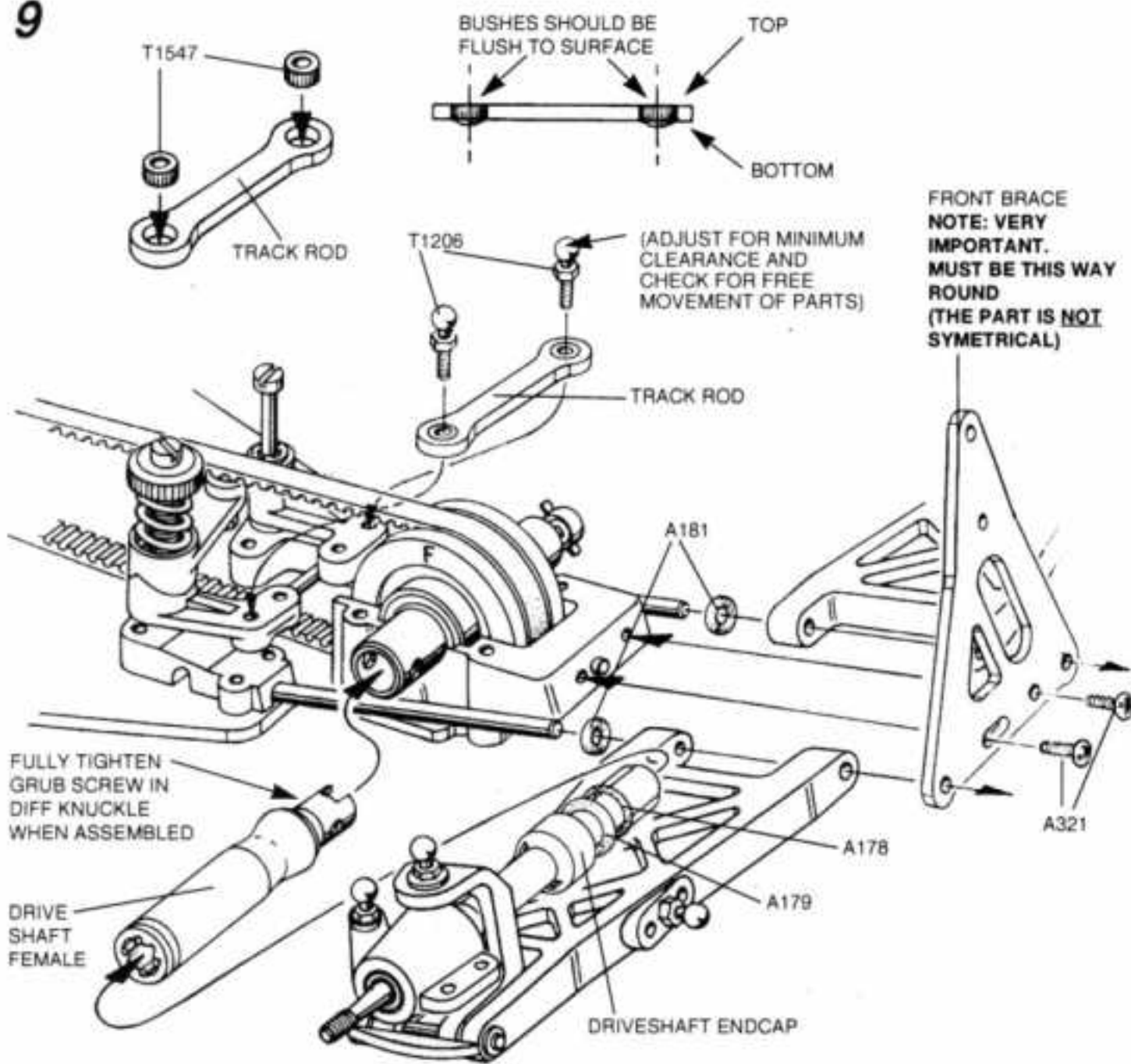

REPEAT DRIVESHAFT ASSEMBLY FOR LEFTHAND SIDE

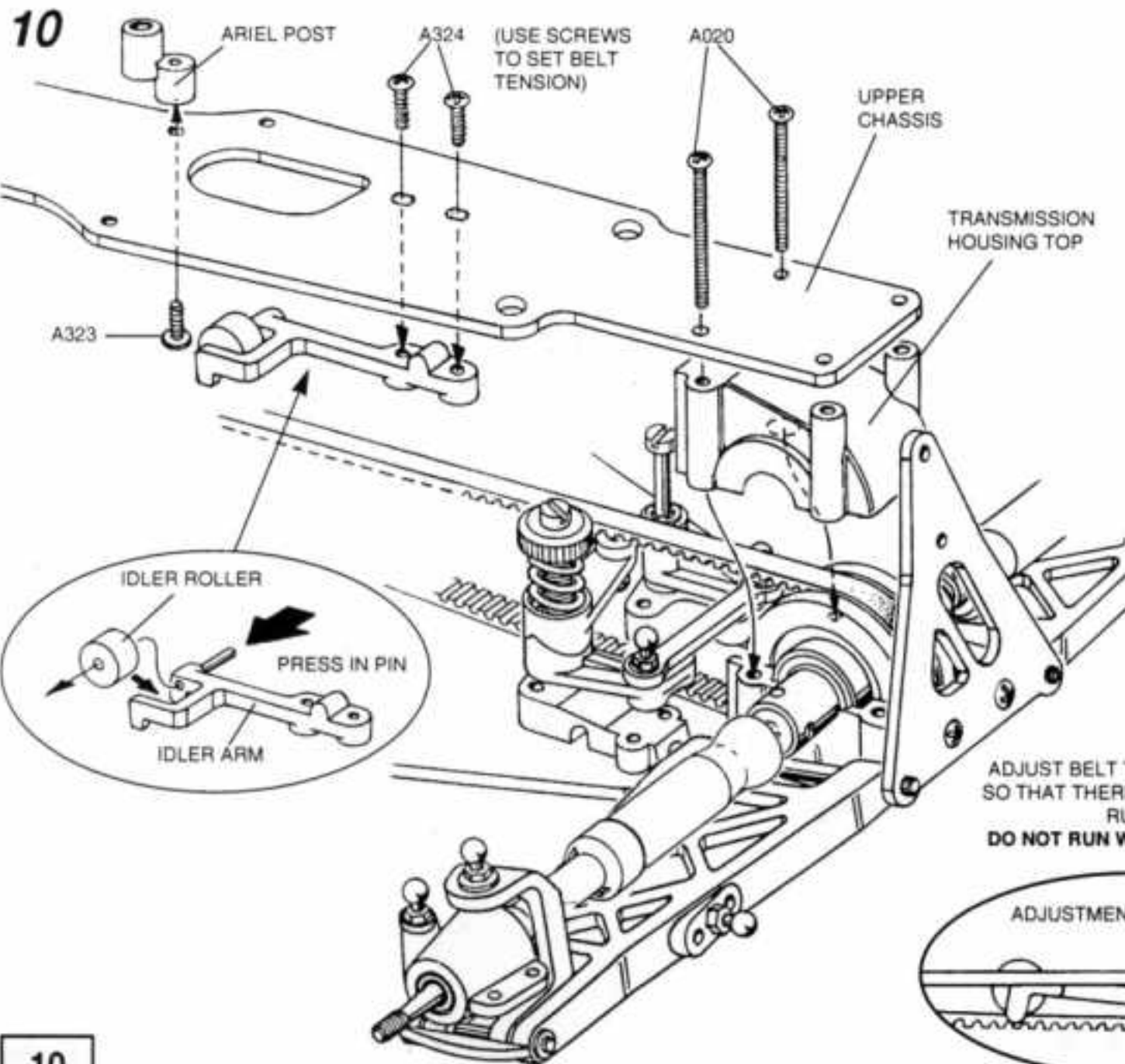

FRONT SUSPENSION

HARDWARE

- T1547 CENTRE TRACKROD BUSH X2
- T1206 BALL STUD LONG X2
- A181 'O' RING RED X2
- A321 No4x1/4" SELFTAP PANHD SCREW X2
- A178 'O'RING - BLACK X2
- A179 'O'RING - BLACK X2
- A020 M3x30mm PANHD SCREW X2
- A324 No4x1/2" SELFTAP PANHD SCREW X2
- A418 PIN 2.5mm DIA X2
- A077 M3 x 3mm GRUB SCREW X2
- A323 No4x3/8" SELFTAP PANHD SCREW X1

11

TAP HOLES IN LOWER TRANSMISSION HOUSING FIRST USING M3 CAPHEAD SCREW

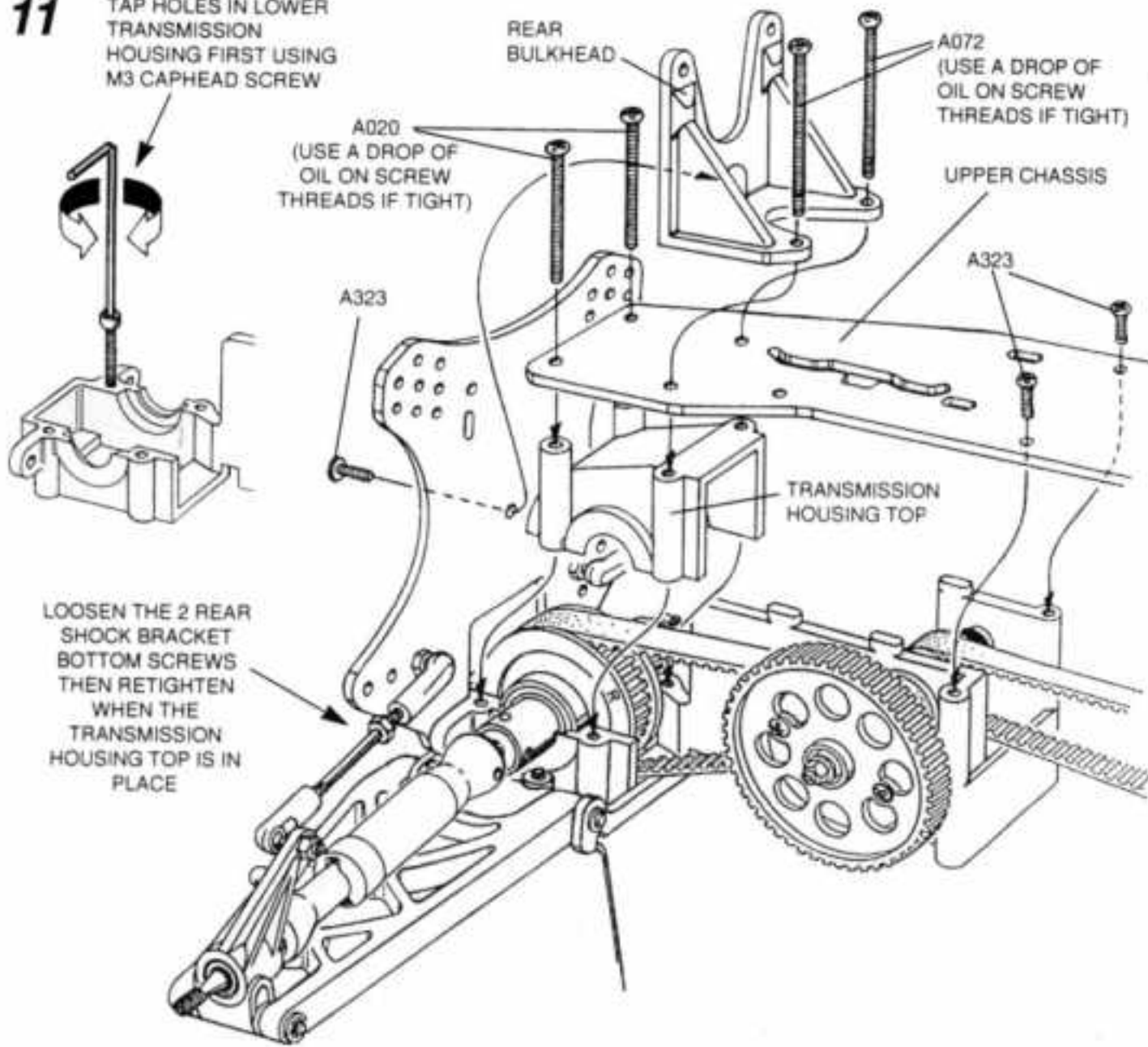

FRONT SUSPENSION

HARDWARE



X2 A020 M3x30mm PANHD SCREW



X4 A072 M3x35mm PANHD SCREW



X3 A323 No4x3/8" SELFTAP PANHD SCREW



X1 A324 No4x1/2" SELFTAP PANHD SCREW



X1 A010 M3x20mm PANHD SCREW

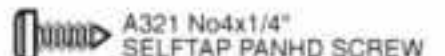

X2 A321 No4x1/4" SELFTAP PANHD SCREW



X3 A051 M3 NYLOC NUT

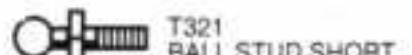

X2 T321 BALL STUD SHORT

12

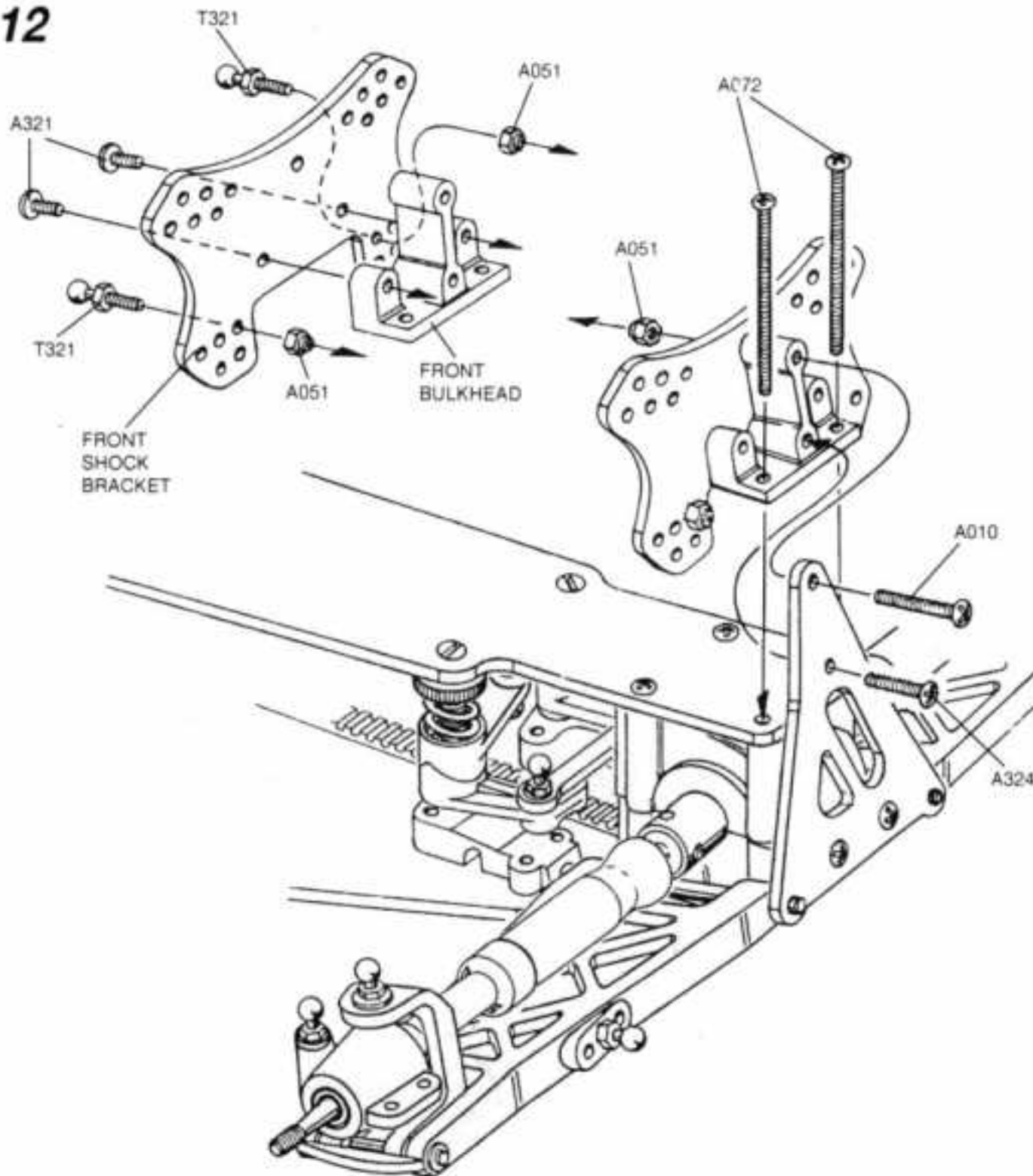



**FRONT SUSPENSION**

**HARDWARE**

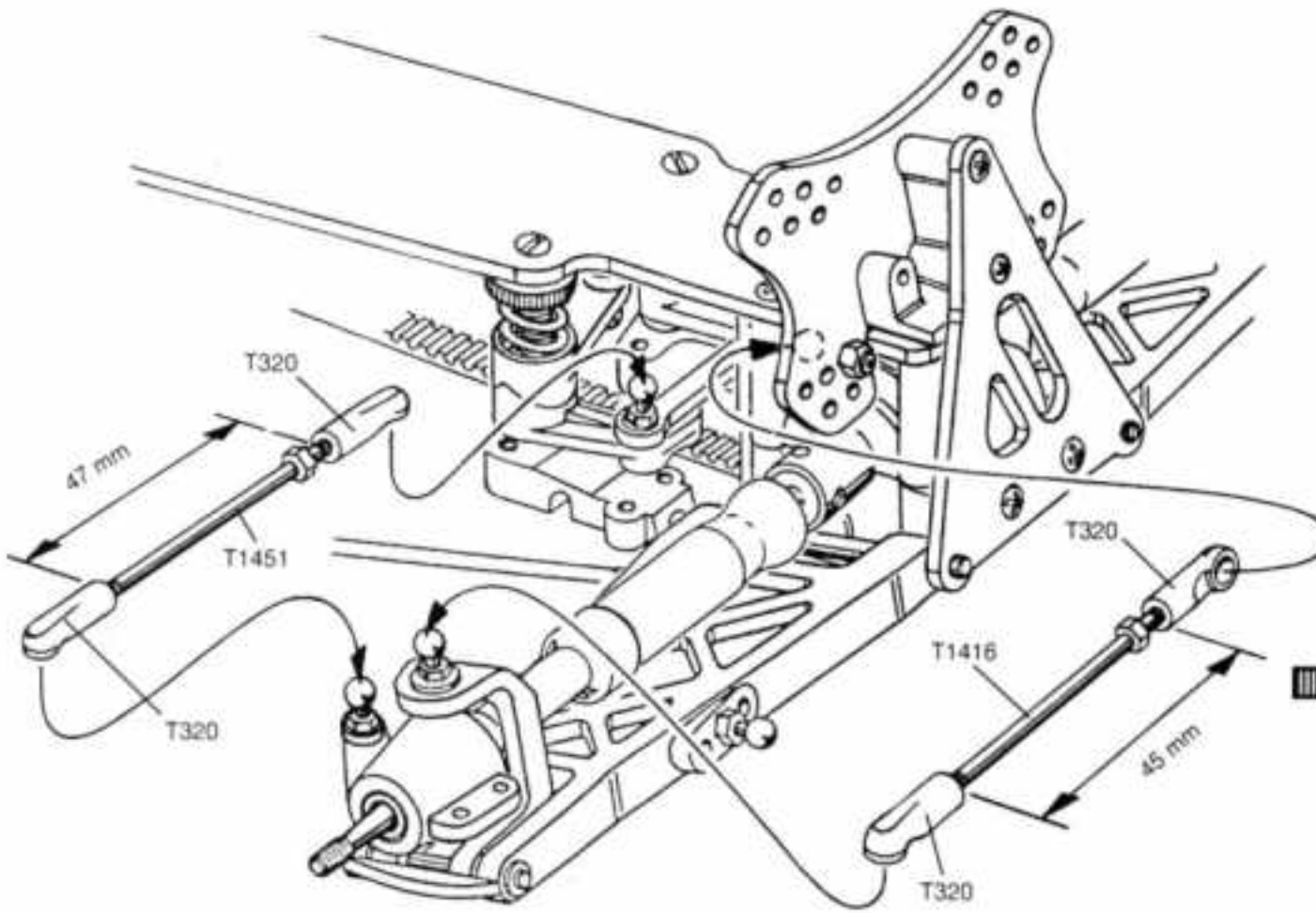

REPEAT FOR LEFTHAND SIDE

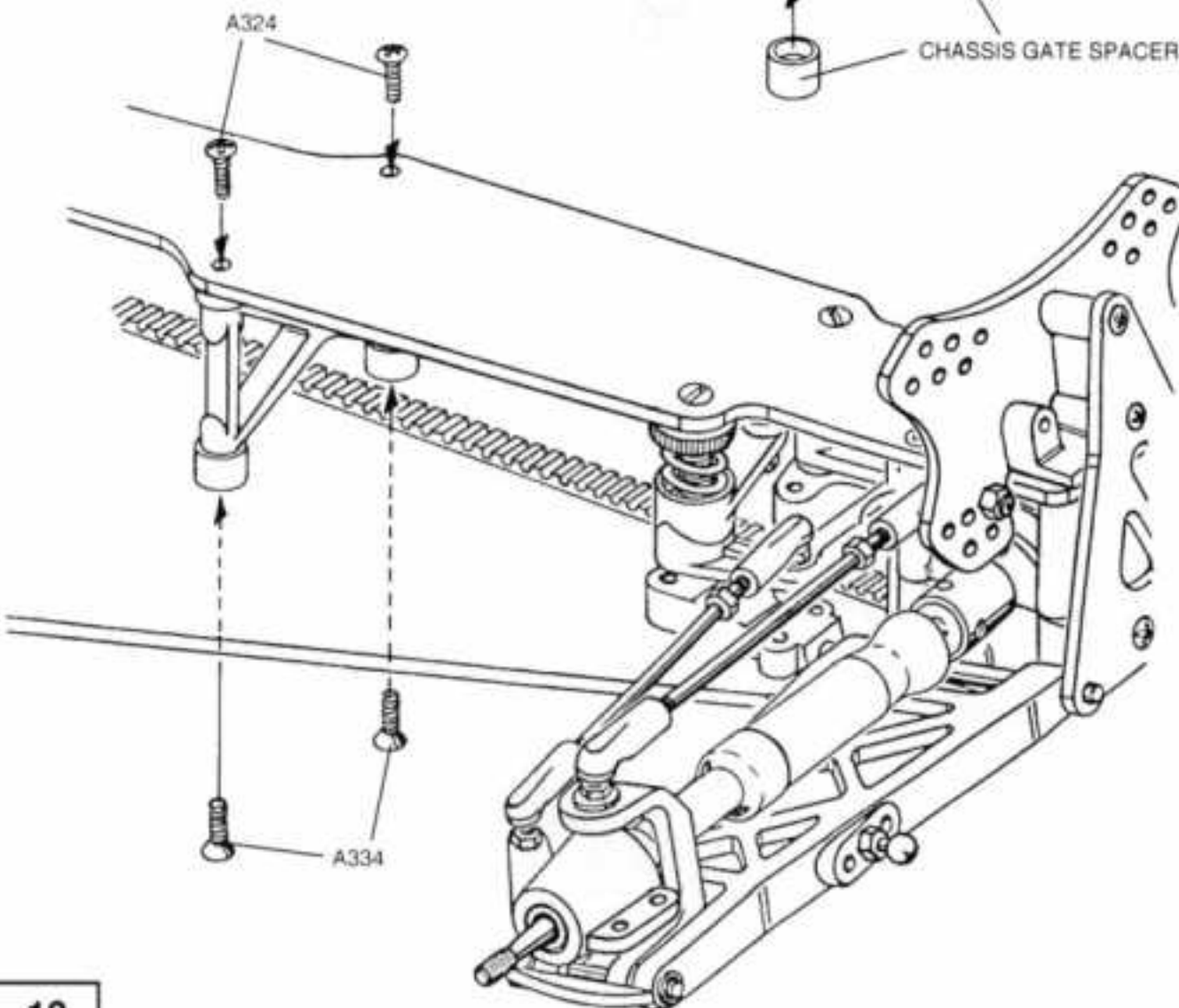
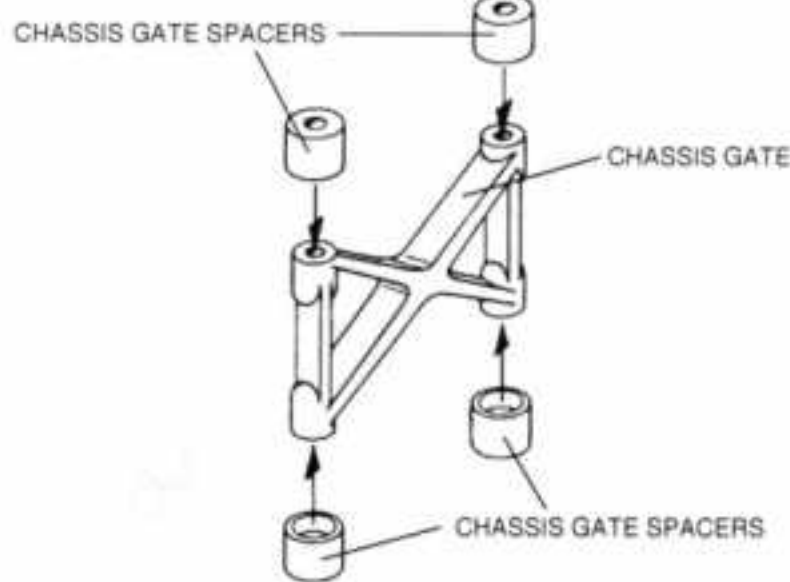
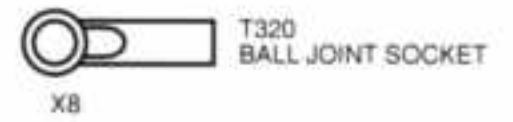
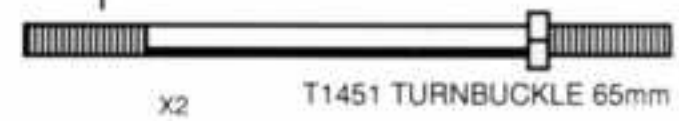

## 2.2" OFF ROAD TYRES

TYRE COMPOUND →	BIBX			GREEN		BLUE		YELLOW		PRICE
	QTY	PART No	PRICE	QTY	PART No	QTY	PART No	QTY	PART No	
2.2" Front 8x20 Mini Spike		<b>U6566I</b>			U6515J		U6517L		U6557Z	
2.2" Rear 12x20 Mini Spike		<b>U6565H</b>			U6516K		U6518M		U6558A	
2.2" Front 2x20 Stud					U6524S		U6523R			
2.2" Rear 8x10 Full Spike					U6528W		U6527V			
2.2" Front 6x10 Full Spike					U6530Y		U6529X			
2.2" Rear 8x10 Cut Spike		<b>U6582Y</b>			U6532A		U6531Z			
2.2" Front 6x10 Cut Spike		<b>U6583Z</b>			U6534C		U6533B			
2.2" Rear 22x34 Micro Spike		<b>U6567J</b>			U6536E		U6535D			
2.2" Front 14x 34 Micro Spike		<b>U6568K</b>			U6538G		U6537F			
2.2" Rear 6x 20 Full Spike		<b>U6584A</b>			U6545N		U6544M			
2.2" Hi Profile Rear Mini Spike		<b>U6561D</b>					<b>U6562E</b>			
2.2" Hi Profile Front Mini Spike		<b>U6563F</b>					<b>U6564G</b>			

## CAT ORIGINALS

TYRE COMPOUND →	BIBX			GREEN		BLUE		YELLOW		PRICE
	QTY	PART No	PRICE	QTY	PART No	QTY	PART No	QTY	PART No	
CAT Rear 4x20 Full Spike					U6514I		T687E		T650T	
CAT Front 3x 20 Full Spike					U6513H		T688F		T652V	
CAT Rear 15x12 Mini Spike					U6512G		T679W			
CAT Front 11x12 Mini Spike					U6511F		T681Y			
CAT Front 2x20 Stud		<b>U6574Q</b>			U6519N		T689G			
CAT Rear 5x24 Mini Spike							T690H			
CAT Front 4x24 Mini Spike							T691I			
CAT Rear 6x20 Block							T692J			
CAT Front 4x20 Block							T693K			
CAT Rear 6x20 Cut Spike							T694L			
CAT Front 1+20 Rib Spike							T695M			
CAT Front Rib		<b>U6575R</b>			U65460					

## SLIMS

TYRE COMPOUND →	BIBX			GREEN		BLUE		YELLOW		PRICE
	QTY	PART No	PRICE	QTY	PART No	QTY	PART No	QTY	PART No	
Slim 2WD Front - Stagger rib		<b>U6569L</b>			U6548Q		U6547P			
Slim 2WD Front - Mini Spike		<b>U6570M</b>			U6550S		U6549R		<b>U6581X</b>	

## TRUCK

TYRE COMPOUND →	BIBX			GREEN		BLUE		YELLOW		PRICE
	QTY	PART No	PRICE	QTY	PART No	QTY	PART No	QTY	PART No	
Truck Racing VEE2		<b>U6576S</b>					U6502W			
Truck Racing VEE4		<b>U6577T</b>					U6503X			
Truck 20x15 Mini Spike		<b>U6578U</b>			U65200		U6508C			
Truck 6x24 Stagger Rib		<b>U6579V</b>			U6526U		U6525T			
Truck 26x39 Micro Spike		<b>6580W</b>					U6542K			

## ON ROAD

QTY	PART No	DESCRIPTION	PRICE
	U6500U	Road & Track - RT1 Front	
	U6501V	Road & Truck - RT1 Rear	
	U6509D	Road & Track - RT2 Front	
	U6510E	Road & Track - RT2 Rear	
	<b>U65720</b>	<b>Road &amp; Track - RT2 Front Green</b>	
	<b>U6573P</b>	<b>Road &amp; Track - RT2 Rear Green</b>	
	U6553V	"Sponges" - 2.2" Aerodisc Rear	
	U6554W	"Sponges" - 2.2" Aerodisc Front	
	U6555X	"Sponges" - Slim - Front	
	U6556Y	"Sponges" - Truck	
	U6559B	"Sponges" - C2000 Rear 2 & 4wd	
	U6560C	"Sponges" - Cougar 2000 Front 2wd	
	<b>U6571N</b>	<b>"Sponges" - CAT 2000 Front 4wd</b>	
		All "Sponges" are trued & glued on wheels	

## FOAM TYRE INSERTS

QTY	PART No	DESCRIPTION	PRICE
	U6539H	CAT Foam Inserts - Front	
	U6540I	CAT Foam Inserts - Rear	
	U6541J	CAT Foam Inserts - Truck	

## WHEELS

QTY	PART No	DESCRIPTION	PRICE
	U1089R	Truck Wheel 2.2" (Fr&Rr)-Natural	
	U396A	Truck Wheel 2.2" (Fr&Rr)-Yellow	
	U224G	Front Wheel-Spoked White - (pr)	
	U225H	Rear Wheel-Isolated White - (pr)	
	U1147X	Aerodisc Rear Wheel - 2.2"	
	U1148Y	Aerodisc Front Wheel - 2.2"	
	U1228B	Slim Front Wheel - White (pr)	
	U1457W	Front Wheel - 2.1" Cougar 2000	
	U1458X	Rear Wheel 2.2" C2000 2 & 4 wd	
	U1516D	Front Wheel 2.2" CAT 2000	

BIBX - New compound specially formulated for superb grip on hard clay tracks. **2nd & 3rd WORLDS!!!**

GREEN - Soft natural compound with high level of grip and natural damping.

BLUE - Natural compound for high traction tracks.

YELLOW - Special compound for indoor racing on polished floors.

**BOLD = NEW**

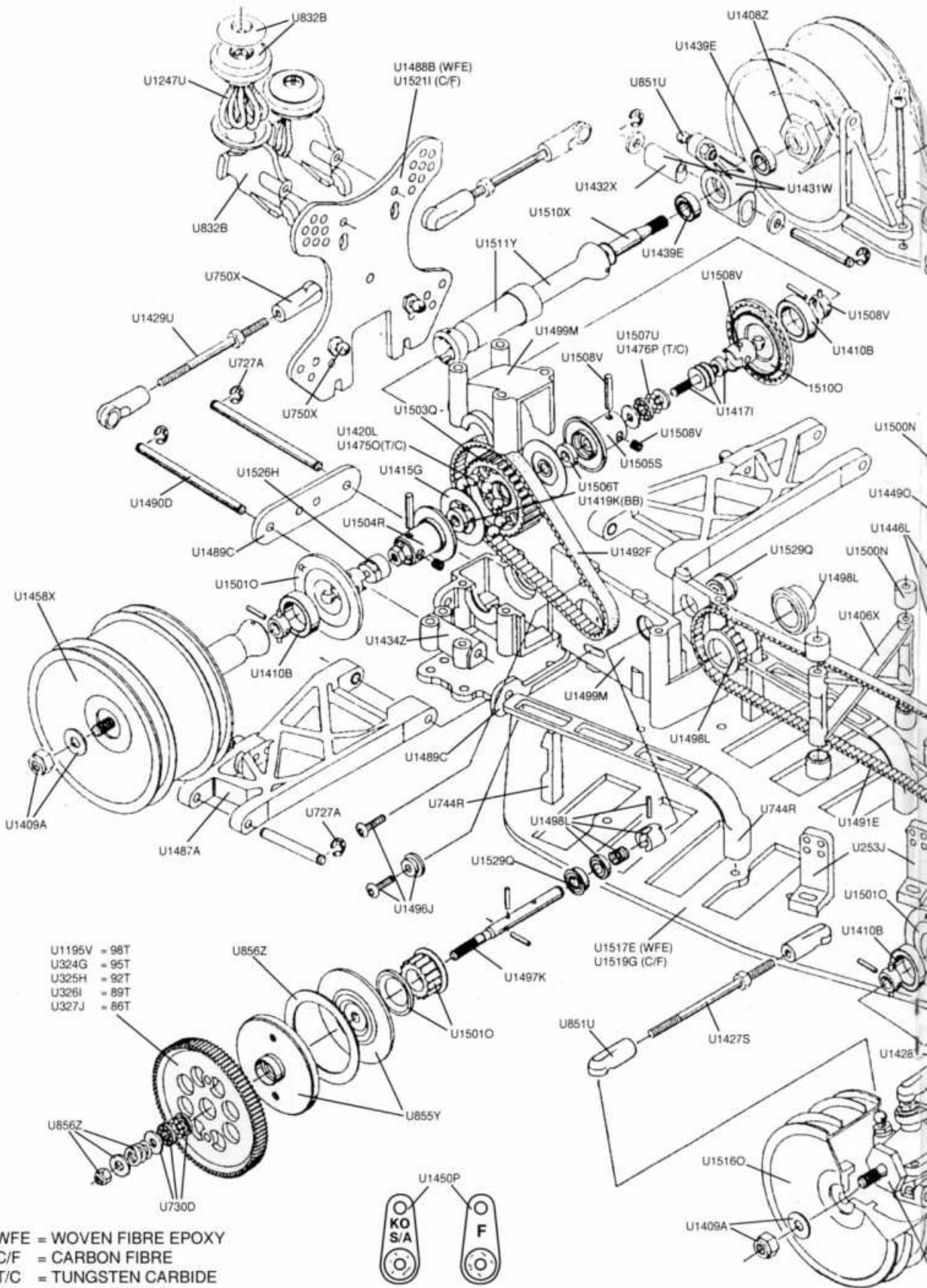

- U1195V = 98T
- U324G = 95T
- U325H = 92T
- U326I = 89T
- U327J = 86T

WFE = WOVEN FIBRE EPOXY  
 C/F = CARBON FIBRE  
 T/C = TUNGSTEN CARBIDE  
 BB = BALL BEARING

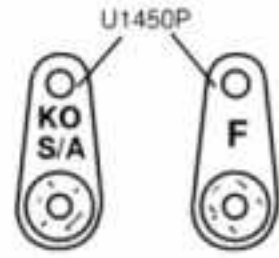



**SPARES DIAGRAM**  
ALTERNATIVES MAY BE FOUND IN THE SPARES LIST

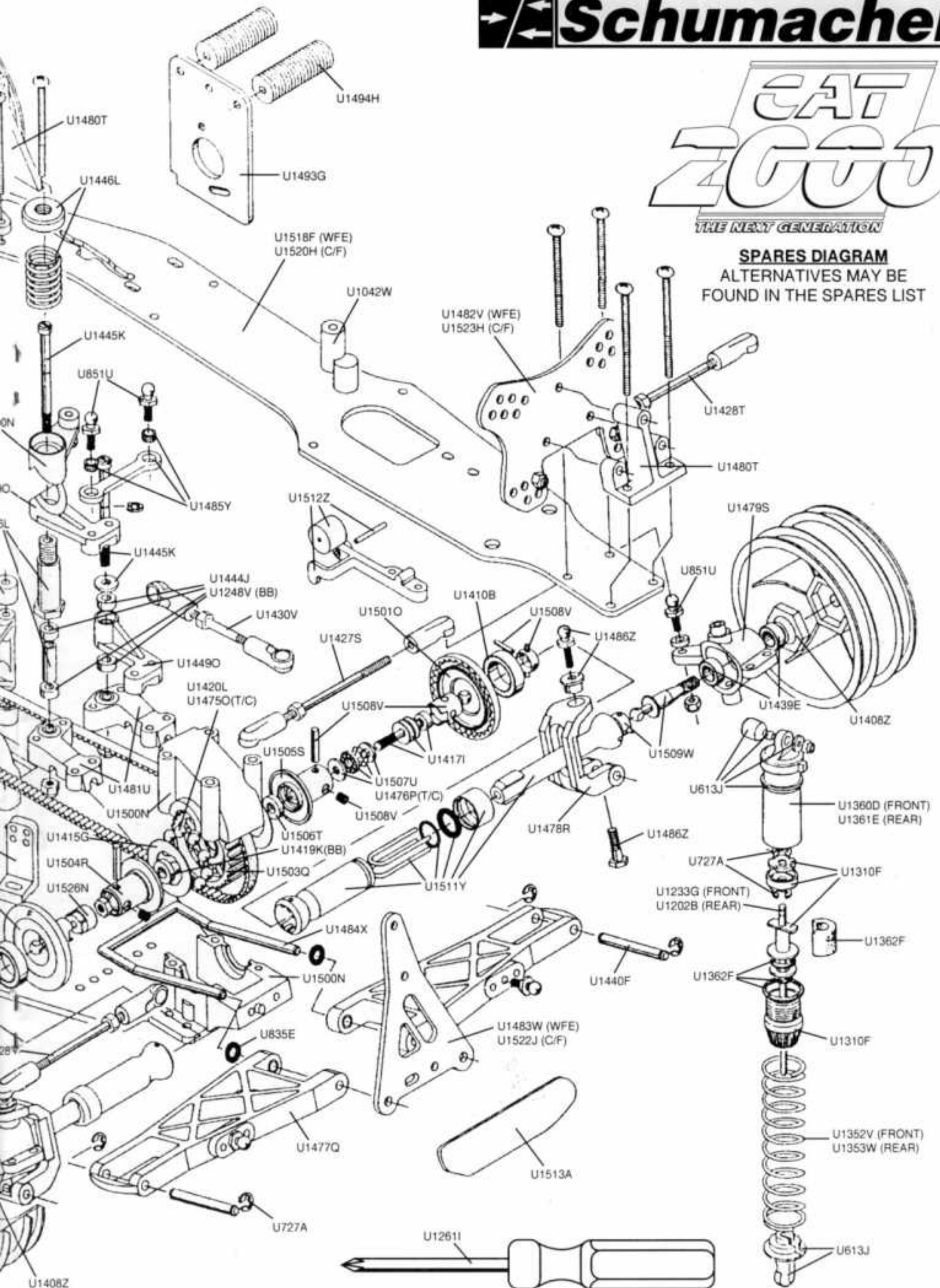

QTY REQ	SPARES NUMBER	DESCRIPTION	UK LIST PRICE
		<b>KITS</b>	
	U460M	CAT 2000 - 4WD Off Road	
		<b>BODY &amp; CHASSIS</b>	
	U119J	Aerial Tube	
	U122M	Velcro 1/2metre x 10mm	
	U1247U	Wing Mount "O" Rings (pk 8)	
	U1403U	Wing & Side Plates - OFF ROAD	
	U1406X	Chassis Gates - C2000 (pk 5)	
	U1513A	Front Bumper - CAT2000	
	U1514B	Instruction Book CAT2000(NSD)	
	U1515C	Decal Sheet - CAT2000	
	U1517E	Lower Chassis,WFE - CAT2000	
	U1518F	Upper Chassis,WFE - CAT2000	
	U253J	Servo Mounts (pr)	
	U5036M	Bodyshell - CAT2000	
	U5037N	Undertray incl. Diff Guard - CAT2000	
	U744R	Q.C. Saddle Pack Strap (pk 2)	
	U832B	Wing Mount Kit	
		<b>SUSPENSION &amp; STEERING</b>	
	U1202B	Piston Rod, Long Shock (pr)	
	U1233G	Piston Rod, Med Shock (pr)	
	U1310F	Shock Mouldings-Vari Click Piston (pr)	
	U1352V	Med Spring Tuning Set - Colour (4prs)	
	U1353W	Long Spring Tuning Set - Colour (4prs)	
	U1357A	PRO Shock Absorbers - medium (pr)	
	U1358B	PRO Shock Absorbers - long (pr)	
	U1360D	PRO Shock Body - medium (ea)	
	U1361E	PRO Shock Body - long (ea)	
	U1362F	PRO Shock Seal pack - (pr)	
	U1426R	Pivot Pin - Rear Outer - C2000	
	U1427S	Turnbuckle - 540unc x 65mm (pr)	
	U1428T	Turnbuckle - 540unc x 60mm (pr)	
	U1429U	Turnbuckle - 540unc x 53mm (pr)	
	U1430V	Turnbuckle - 540unc x 39mm (pr)	
	U1431W	Rear Hub Carrier & Inserts - C2000 (pr)	
	U1432X	Toe In Inserts - Rear C2000 (3prs)	
	U1434Z	Rear Pivot Block- C2000 (pr)	
	U1439E	Ball Bearing 5x9x3 (pr)	
	U1440F	Pivot Pin - Front Outer & King Pin	
	U1444J	Bush 1/8" x 1/4" (pk 4)	
	U1445K	Steering Posts & Washer-C2000 (pr)	
	U1446L	Servo Saver - C2000	
	U1449O	Steering Levers - C2000 (pr)	
	U1450P	Track Rod and Servo Horns	
	U1458X	Rear Wheel 2.2" - C2000(pr)	
	U1477Q	Front Wishbones - CAT2000 4WD (pr)	
	U1478R	Steering Yokes - CAT2000 (pr)	
	U1479S	Front Hub Carriers - CAT2000 (pr)	
	U1480T	Front & Rear Bulkheads - CAT2000	
	U1481U	Front Pivot Blocks - CAT2000	
	U1482V	Front Shock Mount, WFE - CAT2000	
	U1483W	Front Shock Brace, WFE - CAT2000 (set3)	
	U1484X	Front Pivot Bar - CAT2000	
	U1485Y	Centre Track Rod - CAT2000(set)	
	U1486Z	Pivot Set-Front Hub Carrier - CAT2000	
	U1487A	Rear Wishbones - CAT2000 (pr)	
	U1488B	Rear Shock Mount,WFE - CAT2000	
	U1489C	Rear Pivot Braces,WFE - CAT2000 (pr)	
	U1490D	Pivot Pin - Rear Inner - CAT2000(pr)	
	U1516D	Front Wheel 2.2" - CAT2000(pr)	
	U613J	Spring Stop & Spacer Moulding (pr)	
	U727A	'E' Clip 1/8" (pk 10)	
	U750X	Ball Joints- Short Stud Ball&Skt (8 prs)	
	U851U	Ball Joints- Long Stud Ball&Skt (8 prs)	
		<b>TRANSMISSION</b>	
	U1301W	Silicone Diff Grease - Tube	
	U1408Z	Hex Wheel Drive - C2000	
	U1409A	Wheel Nuts - C2000 (4 sets)	
	U1410B	Ball Bearing - 10x15x4 (pr)	

QTY REQ	SPARES NUMBER	DESCRIPTION	UKLIST PRICE
	U1529Q	Ball Bearing - 4x8x3 flanged (pr)	
	U1415G	Diff Washer - 18mm - C2000 (pr)	
	U1417I	Diff Screw, Disc Springs & Spacer - C2	
	U1420L	Diff Balls - 4mm Carbon Chrome ( pk10)	
	U1491E	Front Drive Belt,170 T x 4mm	
	U1492F	Rear Drive Belt, 65 T x 6mm	
	U1493G	Motor Plate - CAT2000	
	U1494H	Motor Heatsinks - CAT2000 (pk 3)	
	U1496J	Motor Screw Set - CAT2000	
	U1497K	Layshaft - CAT2000	
	U1498L	One Way Pulley Set - CAT2000	
	U1499M	Rear Trans Housings - CAT2000	
	U1500N	Front Trans Housings - CAT2000	
	U1501O	Layshaft Pulley & Diff Flanges - CAT2000	
	U1502P	18mm Diff, Assembled - CAT2000	
	U1503Q	18mm Diff Pulley - CAT2000	
	U1504R	Washer Carrier,Co-Ax U/J-C2000(male)	
	U1505S	Washer Carrier,Co-Ax U/J-C2000(Female)	
	U1506T	Bushings, 4x8x2mm - C2000(pr)	
	U1507U	Diff Thrust Bearing - C2000	
	U1508V	Inboard Co-Ax U/J - C2000 (ea)	
	U1509W	Front Ax Co-Ax U/J - CAT2000 (ea)	
	U1510X	Rear Ax Co-Ax U/J - C2000 (ea)	
	U1511Y	Driveshafts, Co-Ax U/J - C2000(pr)	
	U1512Z	Idler Set, Front Belt - CAT2000	
	U1526N	Diff Nut Lock, Co-Ax U/J - C2000	
	U730D	Thrust Bearing 1/8" x 5/16"	
	U855Y	Thrust Plate&Drive Hub Slipper	
	U856Z	Repair Kit - Q.C. Slipper	
		<b>SPEED SECRETS - TUNING PARTS</b>	
	U1195V	98T Q.C. Slipper Gear - 48 D.P.	
	U1248V	Ballbearing - C2000 Steering (pk 2)	
	U1261I	Pozi Screw Driver No. 1	
	U1419K	Ball Bearing 4x8x2mm (pr)	
	U14750	Tungsten Carbide Diff Balls 4mm (pk 10)	
	U1476P	Tungsten Carbide Balls 1/16" (pk 9)	
<b>NEW</b>	U1530R	Rear Anti Roll Bar - CAT2000	
<b>NEW</b>	U1531S	Bump Steer Set - CAT2000	
<b>NEW</b>	U1532T	Castor Blocks 5 Deg. - CAT2000 (pr)	
	U1519G	Lower Chassis, C/F - CAT2000	
	U1520H	Upper Chassis, C/F - CAT2000	
	U1521I	Rear Shock Mount, C/F - CAT2000	
	U1522J	Front Shock Brace, C/F - CAT2000 (set 3)	
	U1523K	Front Shock Mount, C/F - CAT2000	
	U1524L	Lexan Gear Cover - CAT2000	
	U1525M	RollerDrive Shaft Conversion(pr)-Co-AxU/J	
	U15270	4mm Rear Drive Belt - CAT2000	
<b>NEW</b>	U1534V	Dual Rate Shock Pistons (2prs)	
<b>NEW</b>	U1553O	Front Body Mount Bkts - CAT 2000	
<b>NEW</b>	U1554P	Rear Body Shock Mount - CAT 2000	
<b>NEW</b>	U1555Q	Ultra Short Fr. Shock Bkt - CAT 2000	
<b>NEW</b>	U1556R	Ultra Short Rr. Shock Bkt.- CAT2000	
<b>NEW</b>	U1557S	Ultra Short Shock Rod (pr)	
<b>NEW</b>	U1558T	Ultra Short Shock Body (ea)	
<b>NEW</b>	U1559U	Ultra Short Red Shocks (pr)	
<b>NEW</b>	U1560V	Touring Car Body Mount Set - CAT2000	
<b>NEW</b>	U1561W	Circuit Buggy Conv. Set - CAT2000	
<b>NEW</b>	U1562X	Touring Car Conversion. - CAT 2000	
<b>NEW</b>	U1563Y	Alloy Transmission Housing - CAT 2000	
	U324G	95T Q.C. Slipper Gear - 48 D.P.	
	U325H	92T Q.C. Slipper Gear - 48 D.P.	
	U326I	89T Q.C. Slipper Gear - 48 D.P.	
	U327J	86T Q.C. Slipper Gear - 48 D.P.	
	U6559B	"SPONGES" - 2.2" C2000 - Rear (NSD)	
	U6571N	"SPONGES" - 2.2" CAT2000 - Front (NSD)	
	U818N	Ball Bearings - Roller D/Shaft (pr)	
	C2000	Fits CAT & Cougar 2000 Models	

1

**REAR X2**

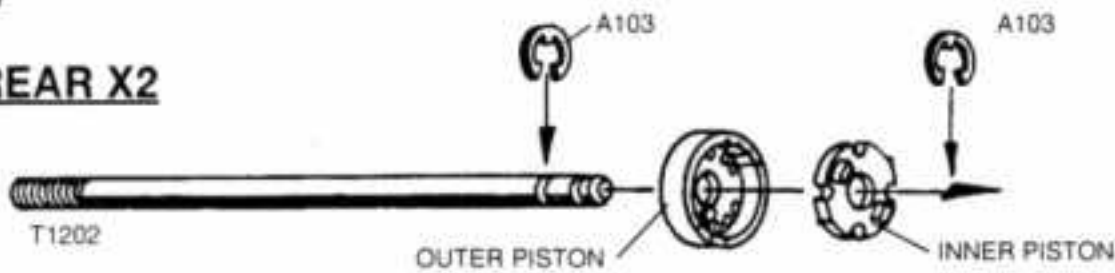

**FRONT X2**

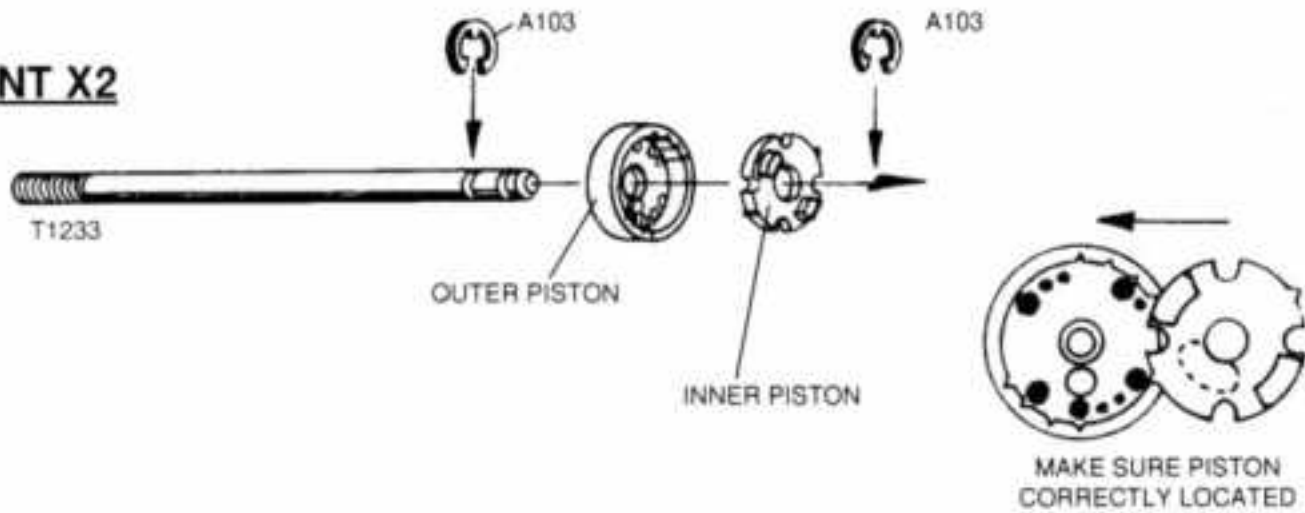

**SHOCK ABSORBERS**

**HARDWARE**

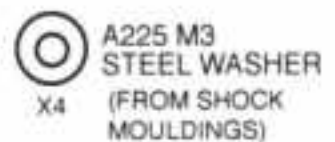
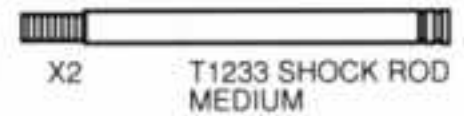

2

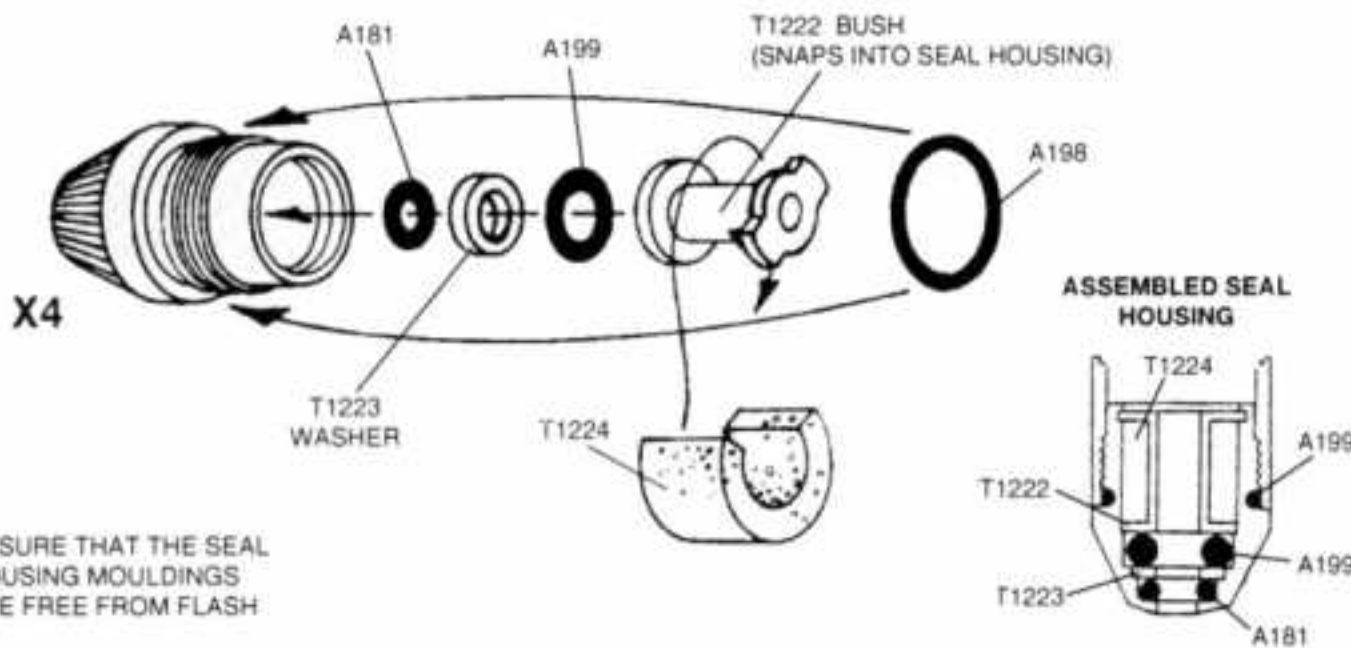

ENSURE THAT THE SEAL HOUSING MOULDINGS ARE FREE FROM FLASH

3

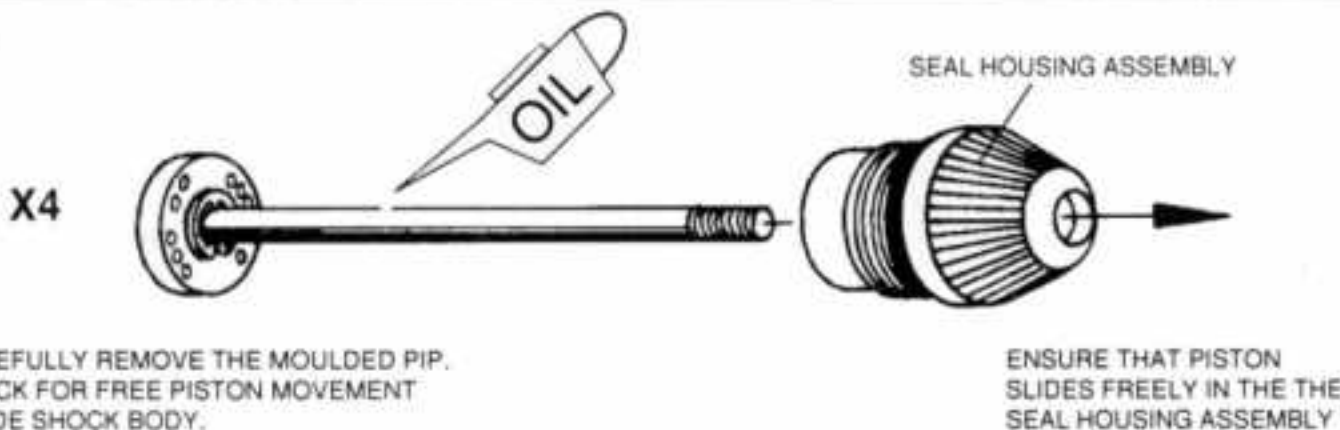

4

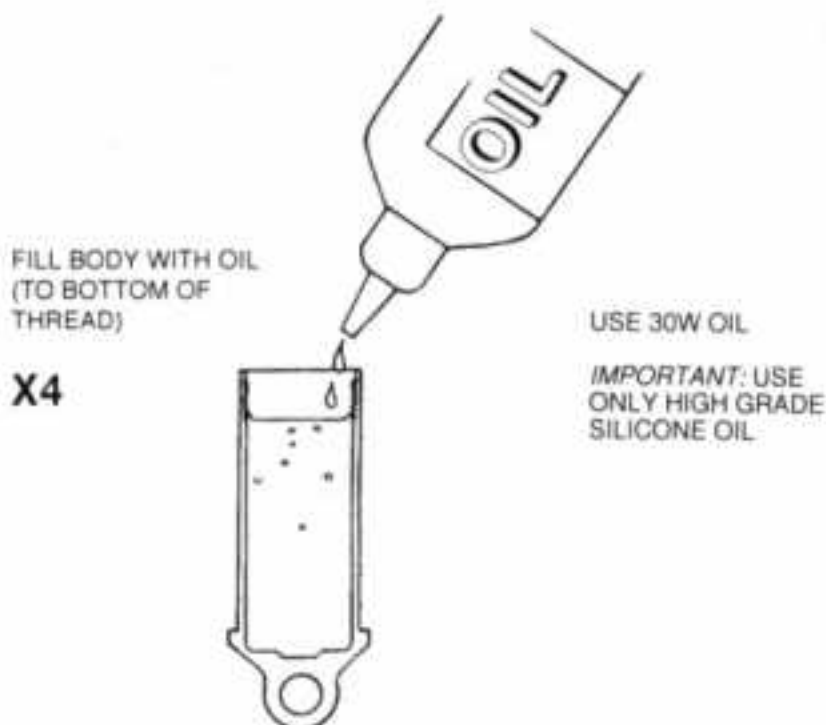

5

DAMPING ADJUSTMENT

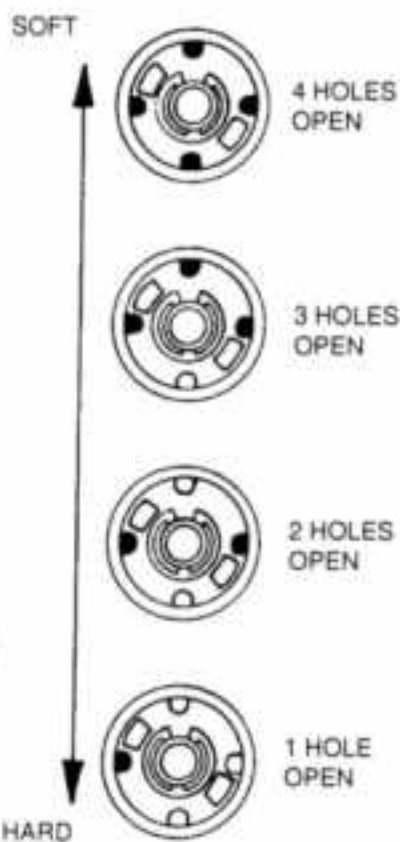
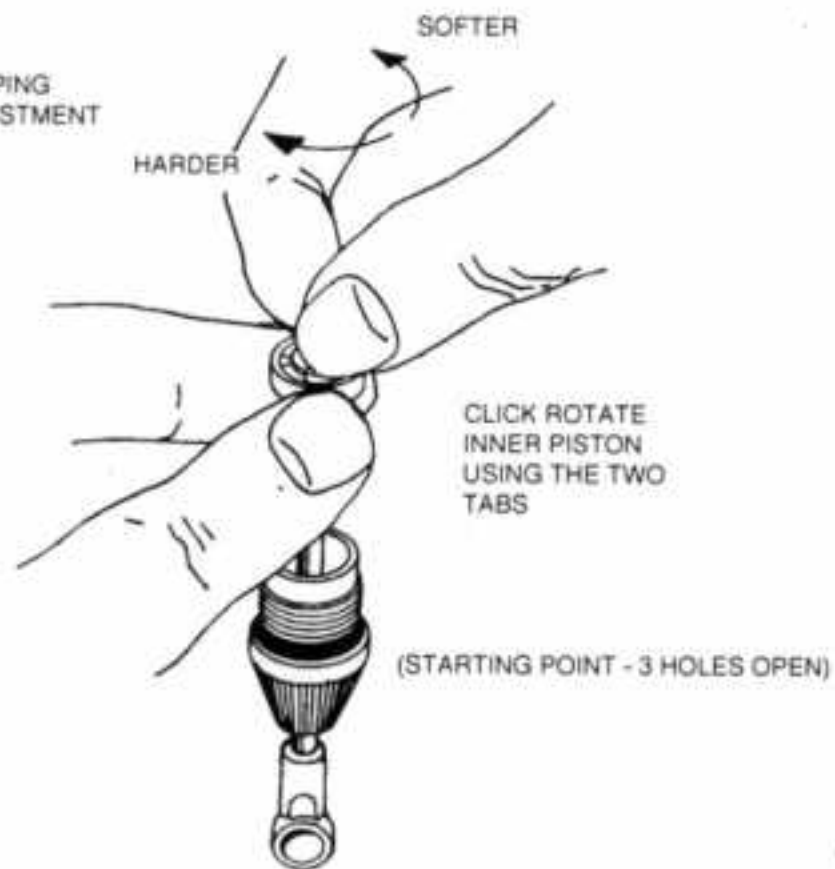

**Schumacher**

**EAT**  
**ZOO**  
THE NEXT GENERATION

**SHOCK ABSORBERS**

**HARDWARE**

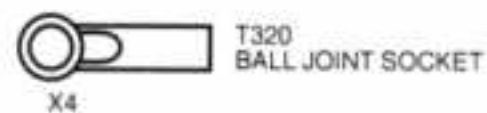

6

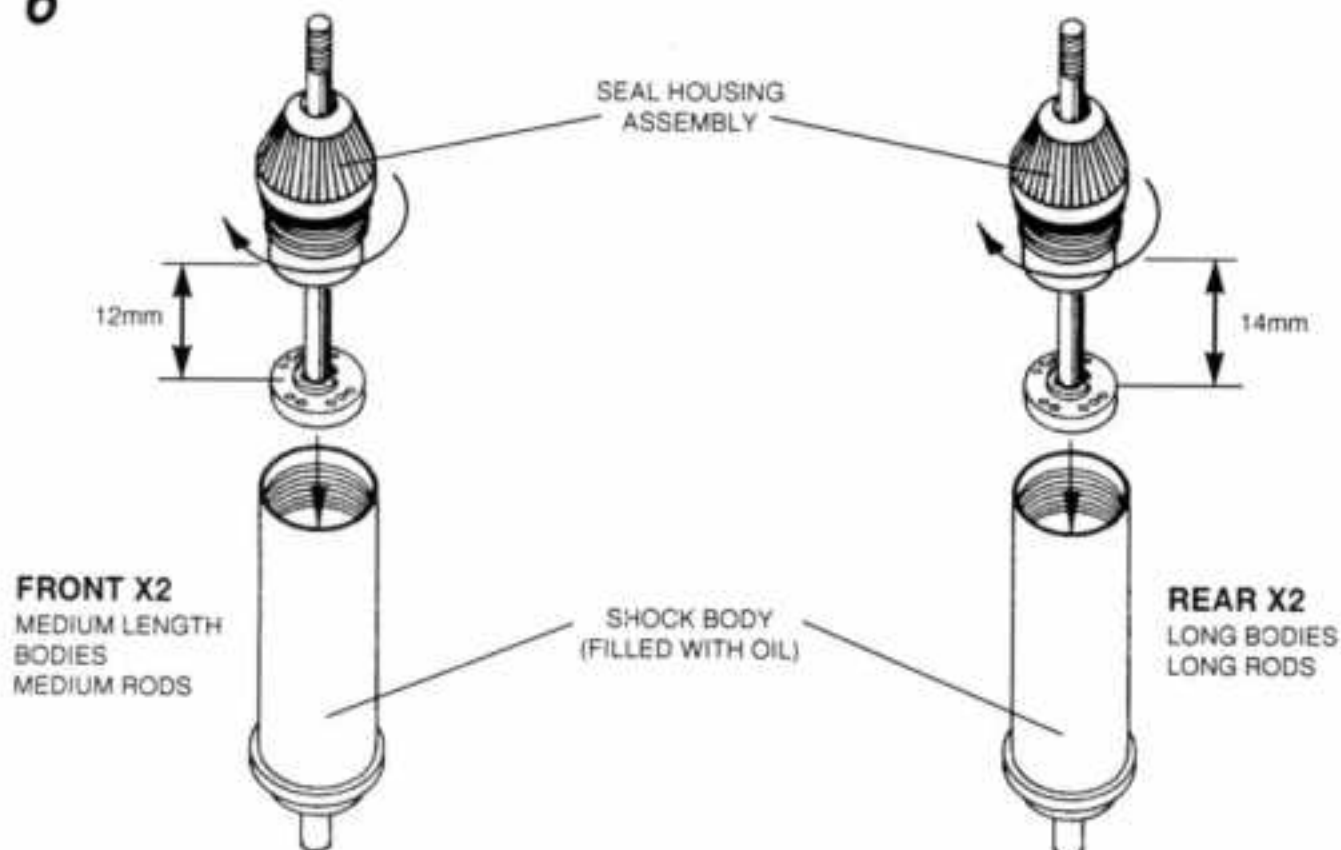

7

NOTE: SEAL HOUSING FULLY SCREWED IN - NO 'O' RING VISIBLE

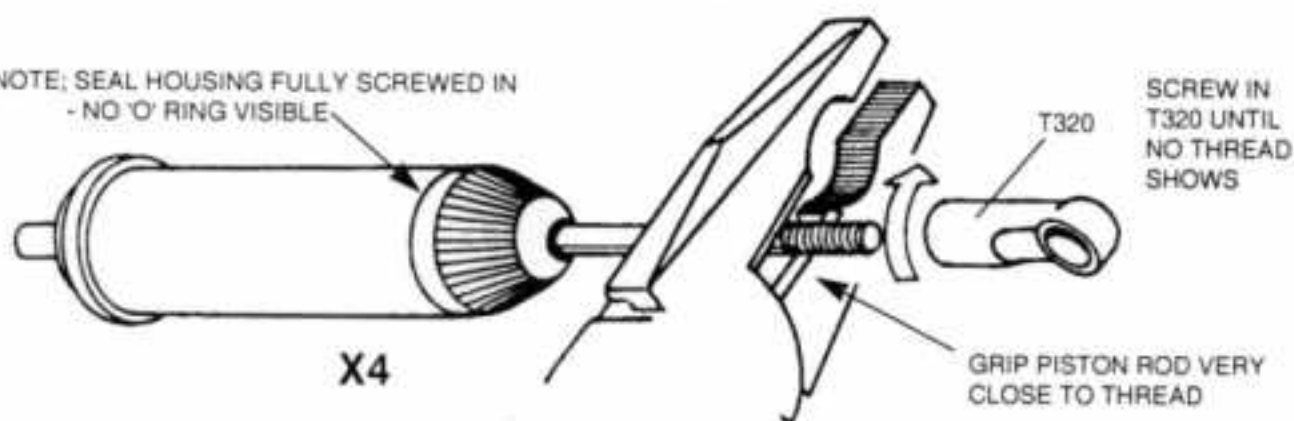

8

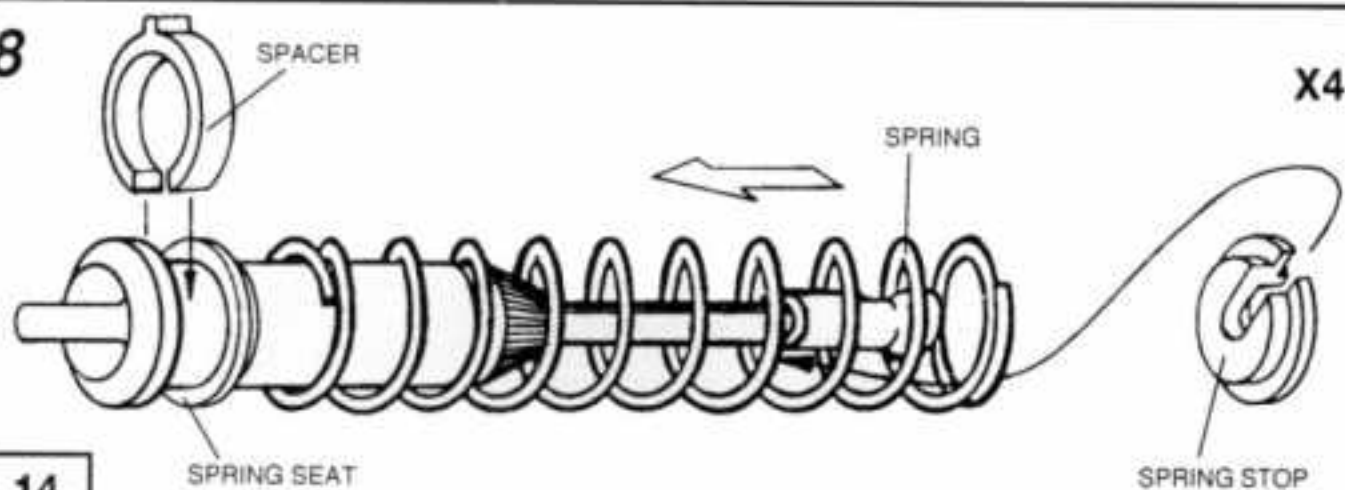

**9 FITTING FRONT SHOCK ABSORBERS**

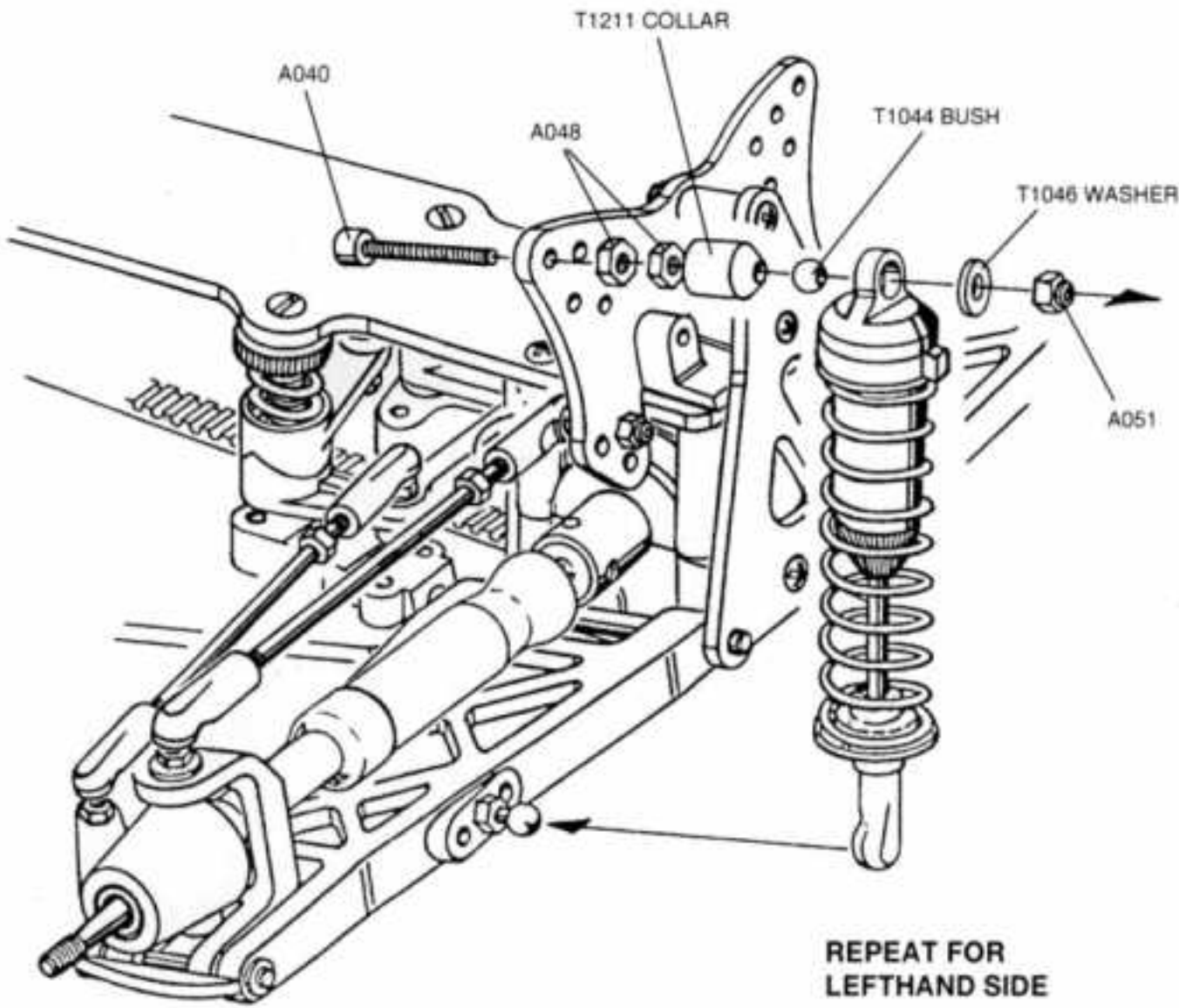

REPEAT FOR LEFTHAND SIDE





**SHOCK ABSORBERS**

**HARDWARE**

 A040  
M3x20mm  
CAPHEAD SCREW  
X4

 A048 M3 NUT  
X8

 A051 M3 NYLOC NUT  
X4

 T1044 SHOCK  
SPHERICAL BUSH  
X4

 T1211  
SHOCK COLLAR  
X4

 T1046 SHOCK  
MOUNT WASHER  
X4

**10 FITTING REAR SHOCK ABSORBERS**

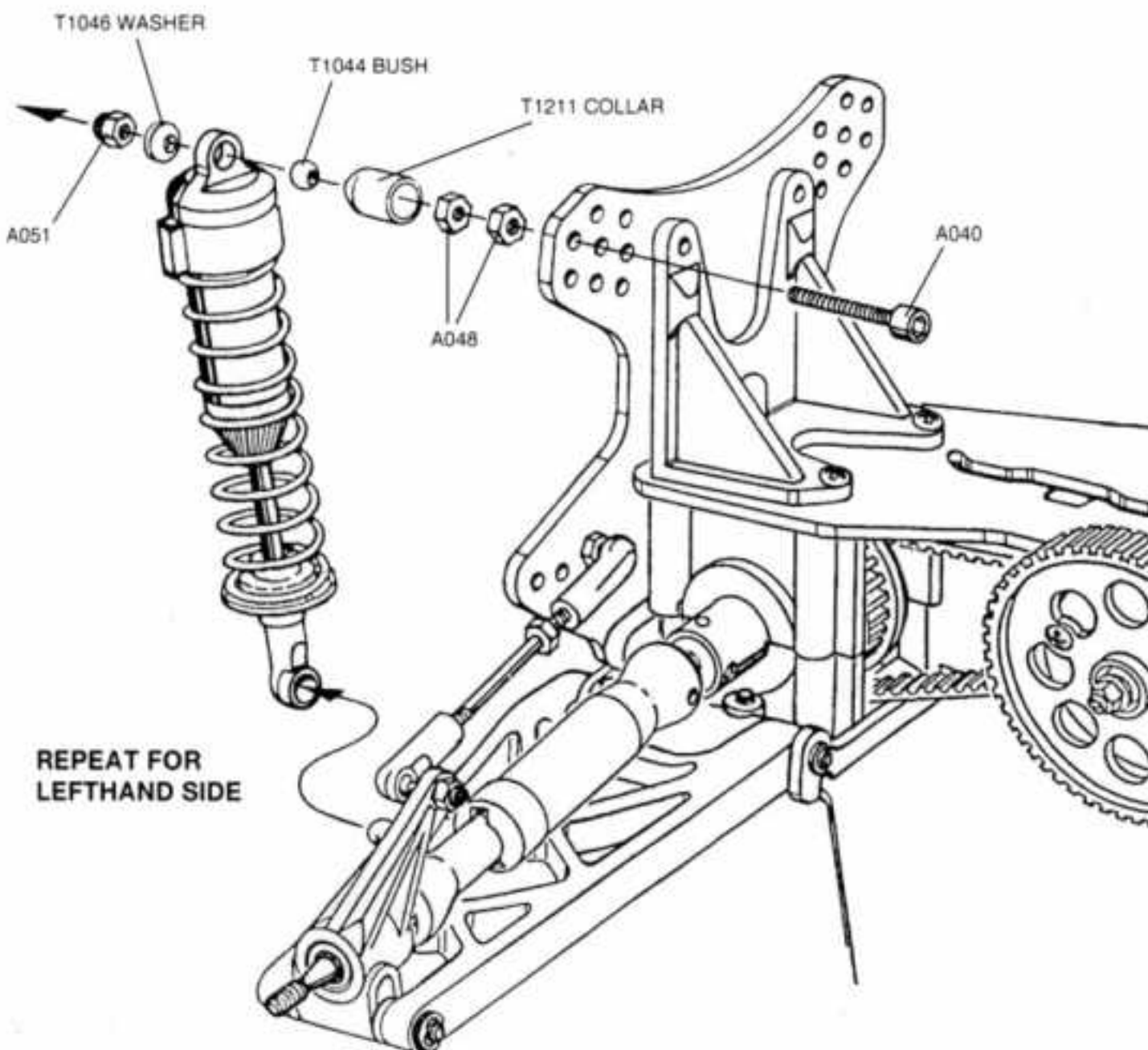

REPEAT FOR LEFTHAND SIDE

**1 FITTING TYRES TO WHEELS**  
 MAKE SURE TYRE BEAD SEATS PROPERLY IN GROOVES OF WHEEL  
 NOTE: DO NOT BOIL CAT 2000 WHEELS - THEY WILL DISTORT.

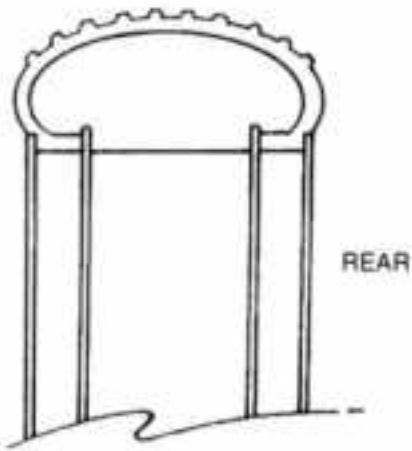
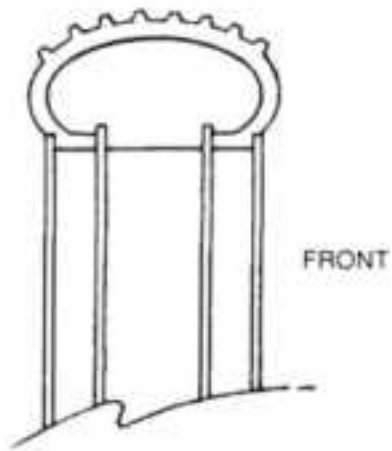

**WHEELS & TYRES**

**HARDWARE**

**2 FITTING FRONT WHEELS**

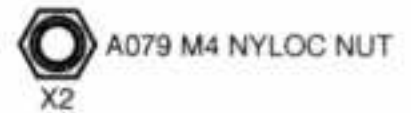
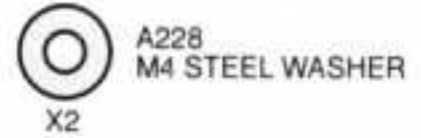
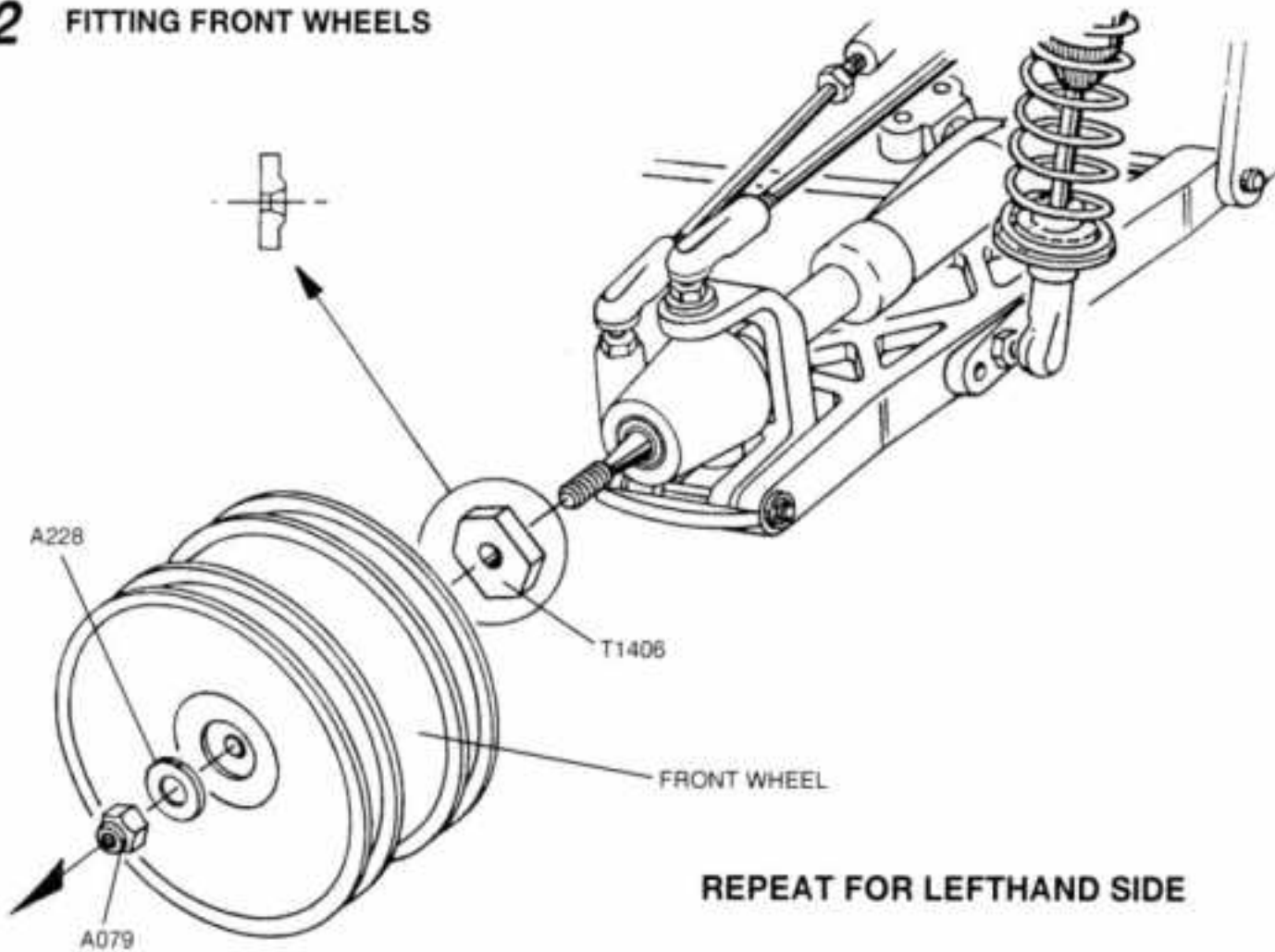

**3 FITTING REAR WHEELS**

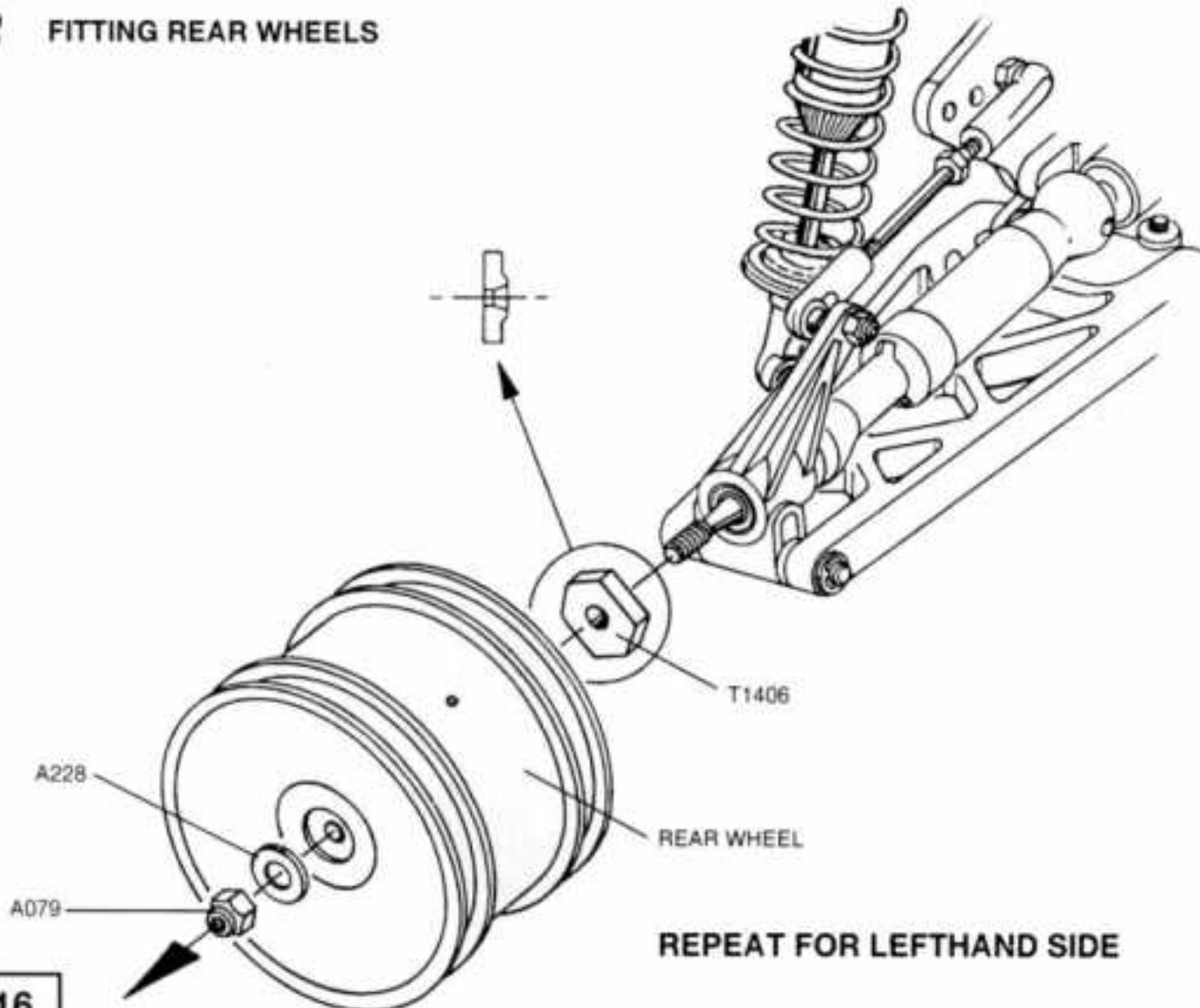

**BODYSHELL**

CUT AWAY SHADED AREAS.  
 USE A FILE OR ABRASIVE PAPER TO SMOOTH THE CUT EDGES.  
 ANY RAGGED EDGES OR SCORE LINES MAY CAUSE THE  
 BODYSHELL TO CRACK OR SPLIT WHEN IN USE.  
 PAINTING: FIRST WASH THE BODYSHELL TO REMOVE ANY OIL OR  
 DIRT. RINSE THOROUGHLY. PAINT THE INSIDE OF THE BODYSHELL  
 AND WING.  
 YOU CAN OBTAIN A COLOUR SCHEME BY MASKING A SECTION  
 WITH TAPE, PAINTING, THEN REMOVING THE TAPE AND PAINTING A  
 DIFFERENT COLOUR.  
 APPLY THE DARKEST COLOUR FIRST.  
 USE DECALS TO FINISH YOUR BODYSHELL.

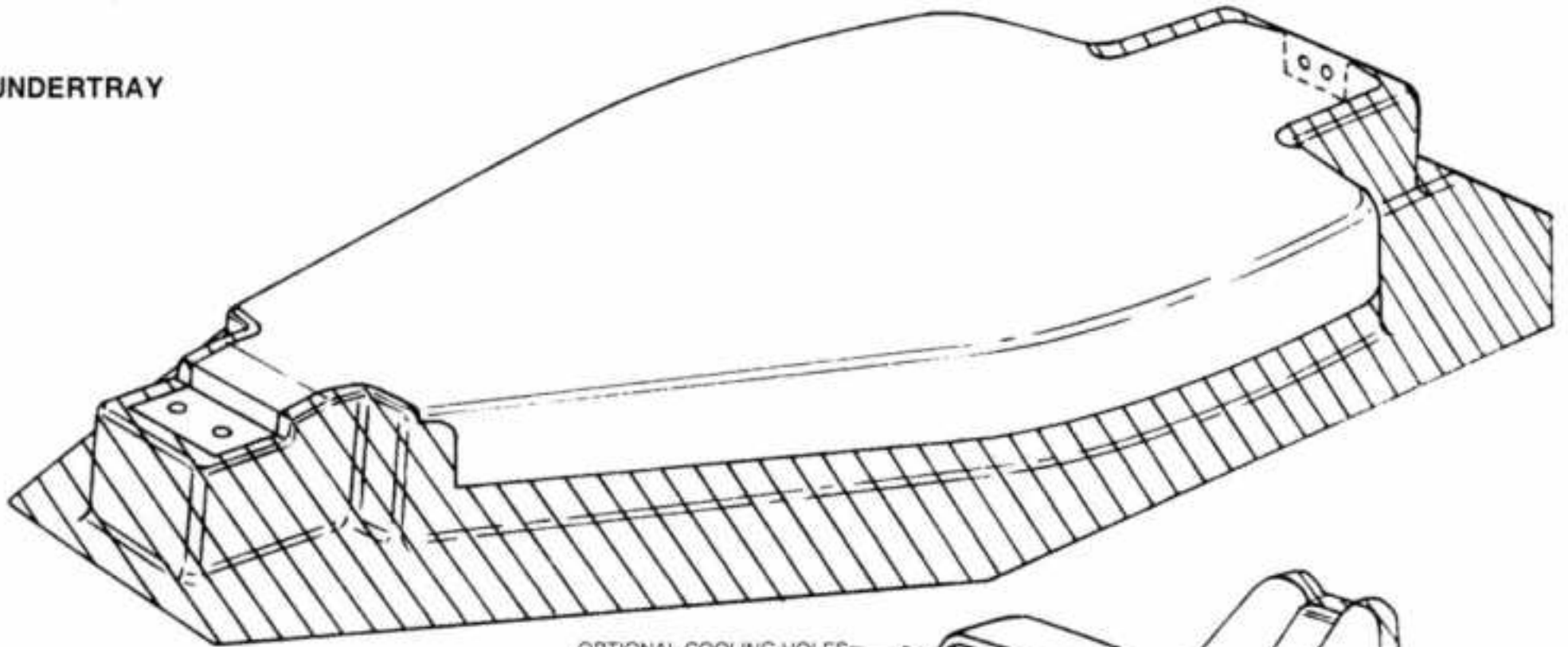
**UNDERTRAY**

OPTIONAL COOLING HOLES

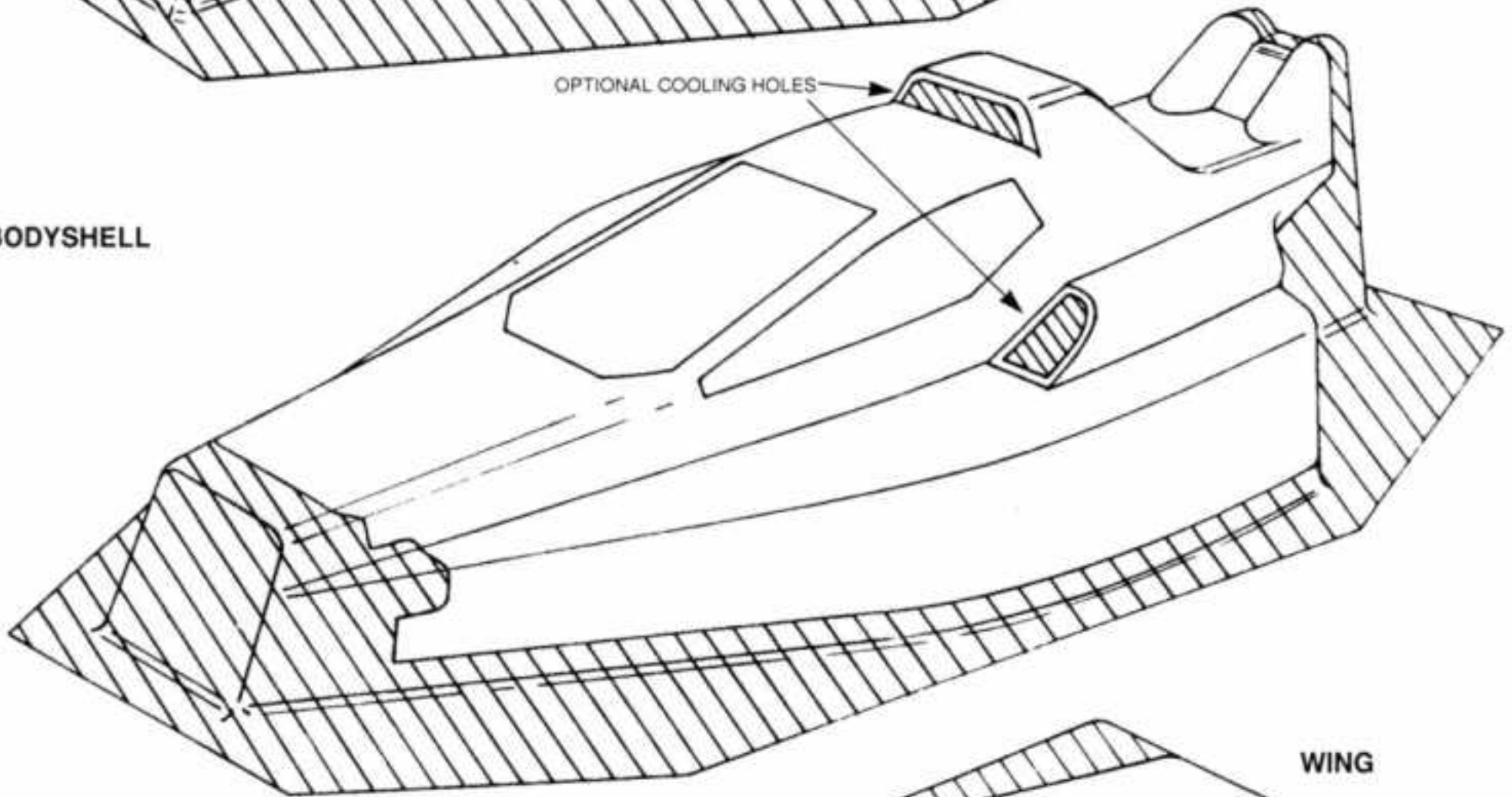
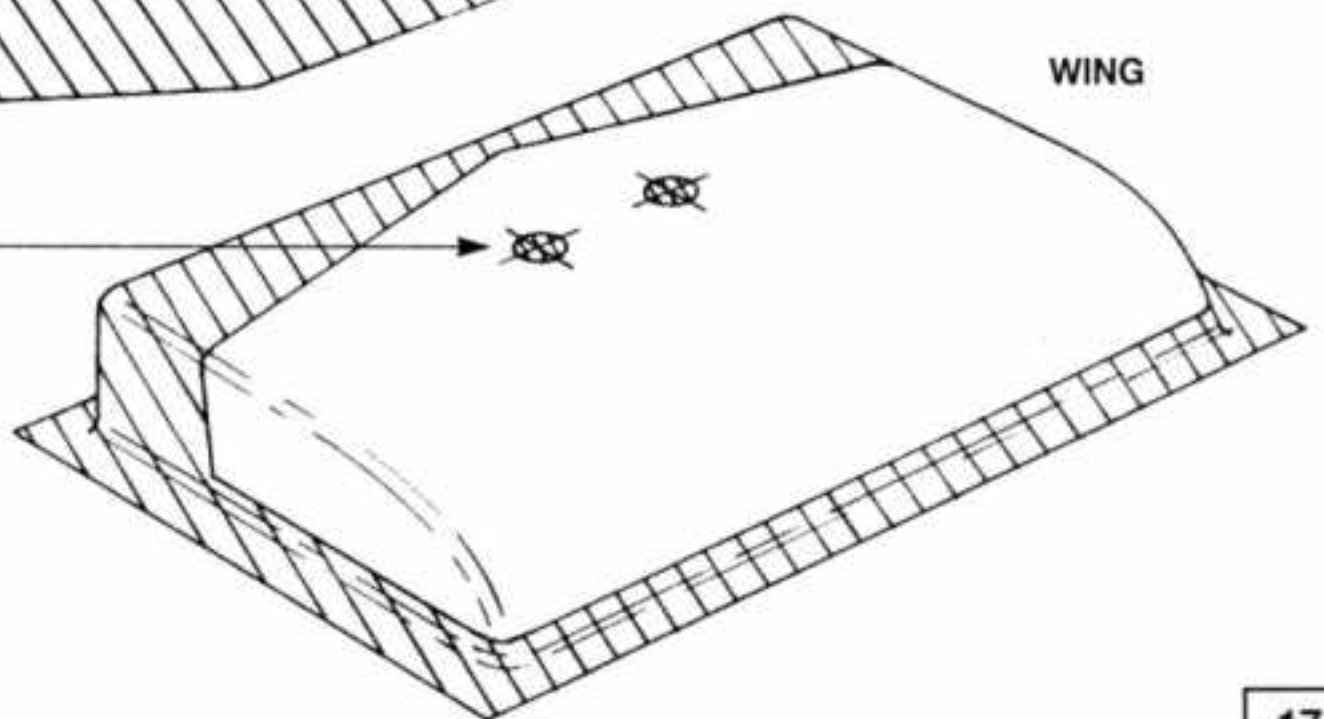
**BODYSHELL****WING**2 HOLES  
8mm. DIA

**WARNING:** MOTOR CLEANING  
 SOLVENTS WILL PERMANENTLY  
 DAMAGE THE POLYCARBONATE  
 BODYSHELL & UNDERTRAY.  
 ALWAYS REMOVE MOTOR BEFORE  
 DOING ANY MAINTENANCE

## FITTING FRONT BUMPER & UNDERTRAY

## BUMPER & UNDERTRAY

### HARDWARE

 A323 No4x3/8"  
SELFTAP PANHD SCREW  
X2

 A321 No4x1/4"  
SELFTAP PANHD SCREW  
X2

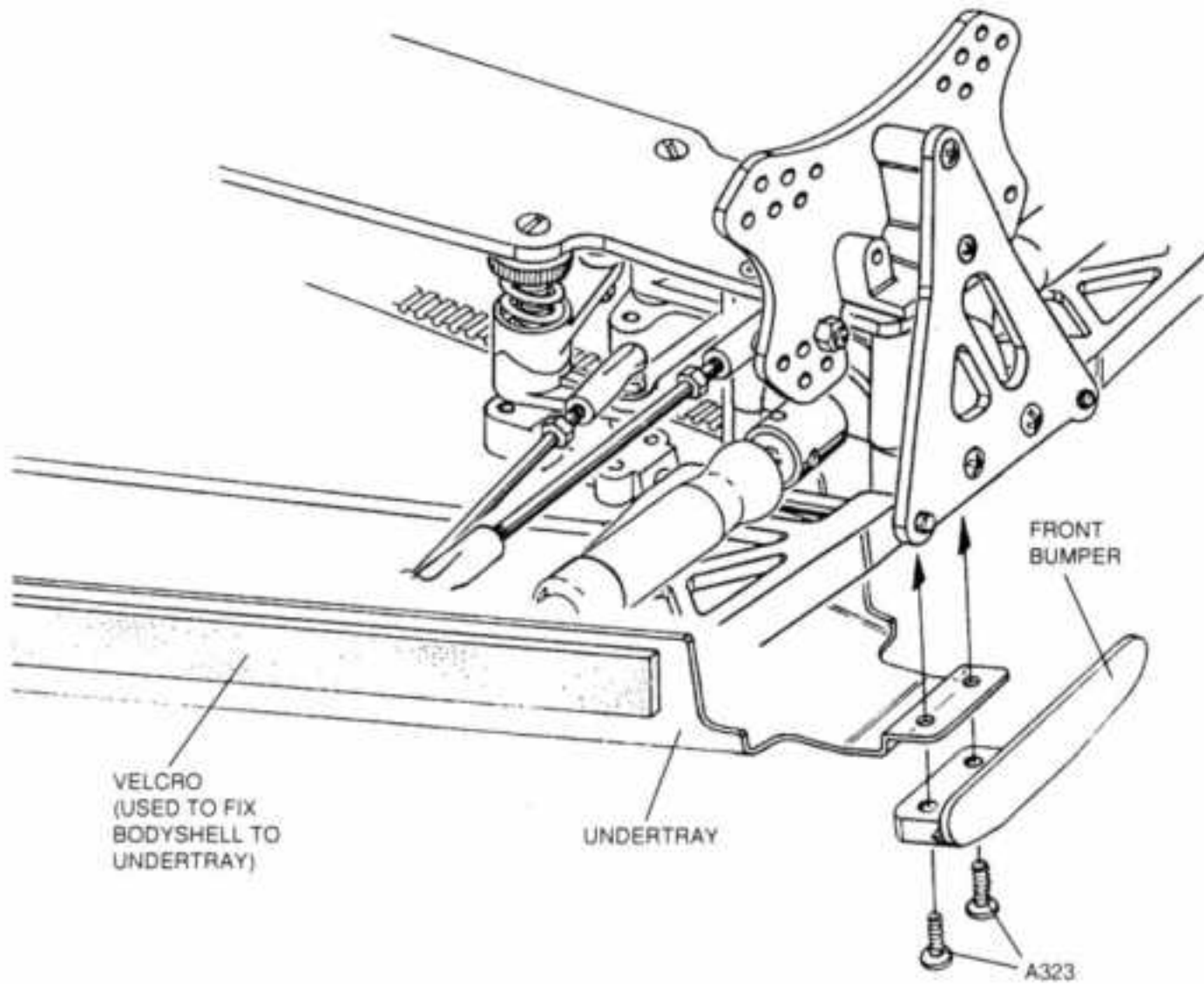

## FITTING UNDERTRAY AT REAR & DIFF GUARD

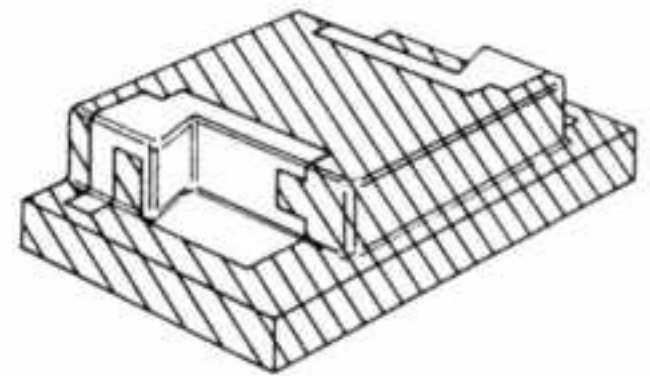
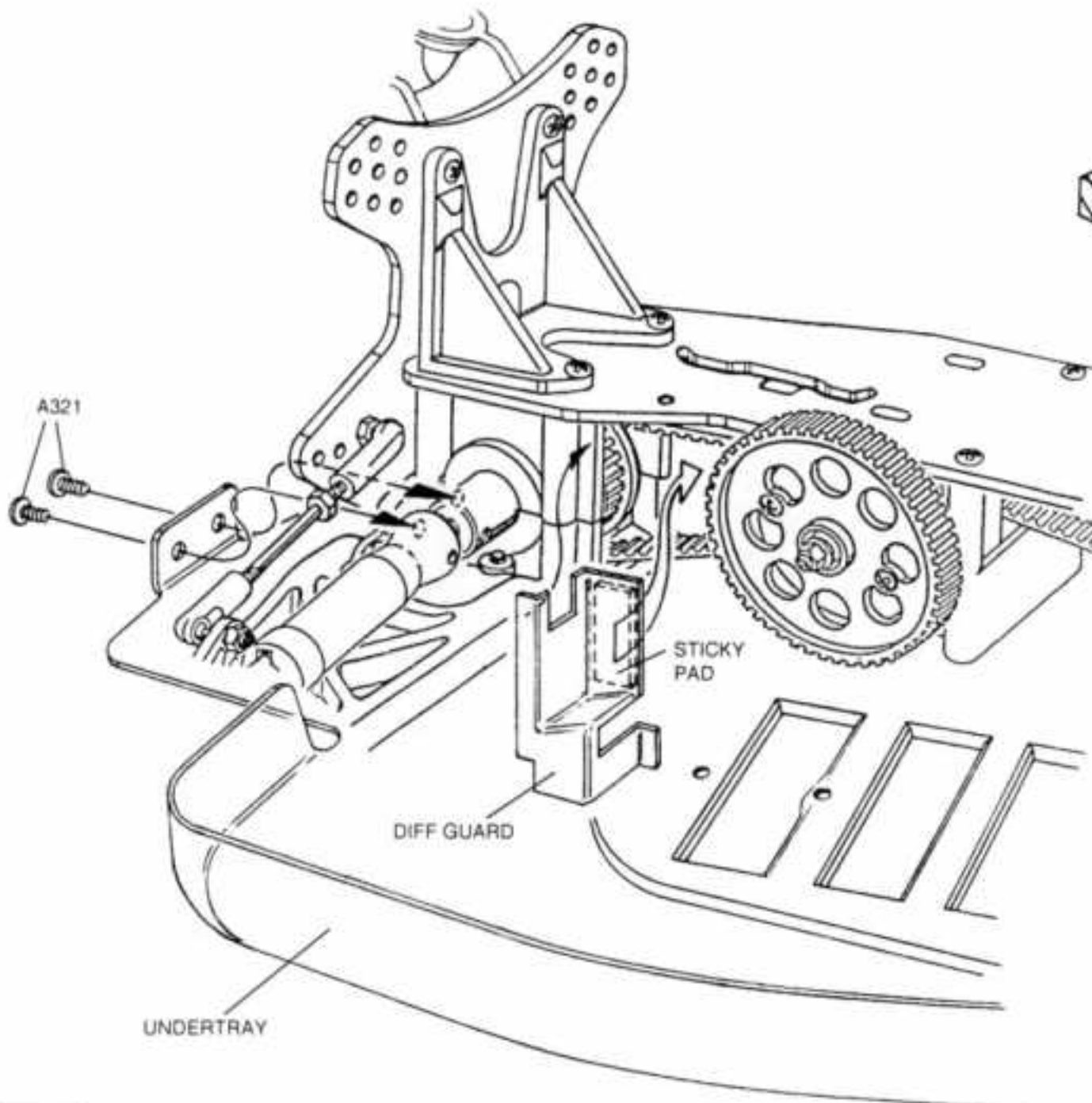

THERE ARE 2 DIFF GUARDS (THEY ARE BOTH THE SAME) CUTAWAY SHADED AREAS. IT IS IMPORTANT TO TRIM THIS PART VERY CAREFULLY. THE BETTER THE LEXAN GUARD FITS THE LESS CHANCE OF STONES GETTING INTO THE DIFF.

**WING**

**HARDWARE**

 A324 No4x1/2" SELFTAP PANHD SCREW  
X2

 A321 No4x1/4" SELFTAP PANHD SCREW  
X2

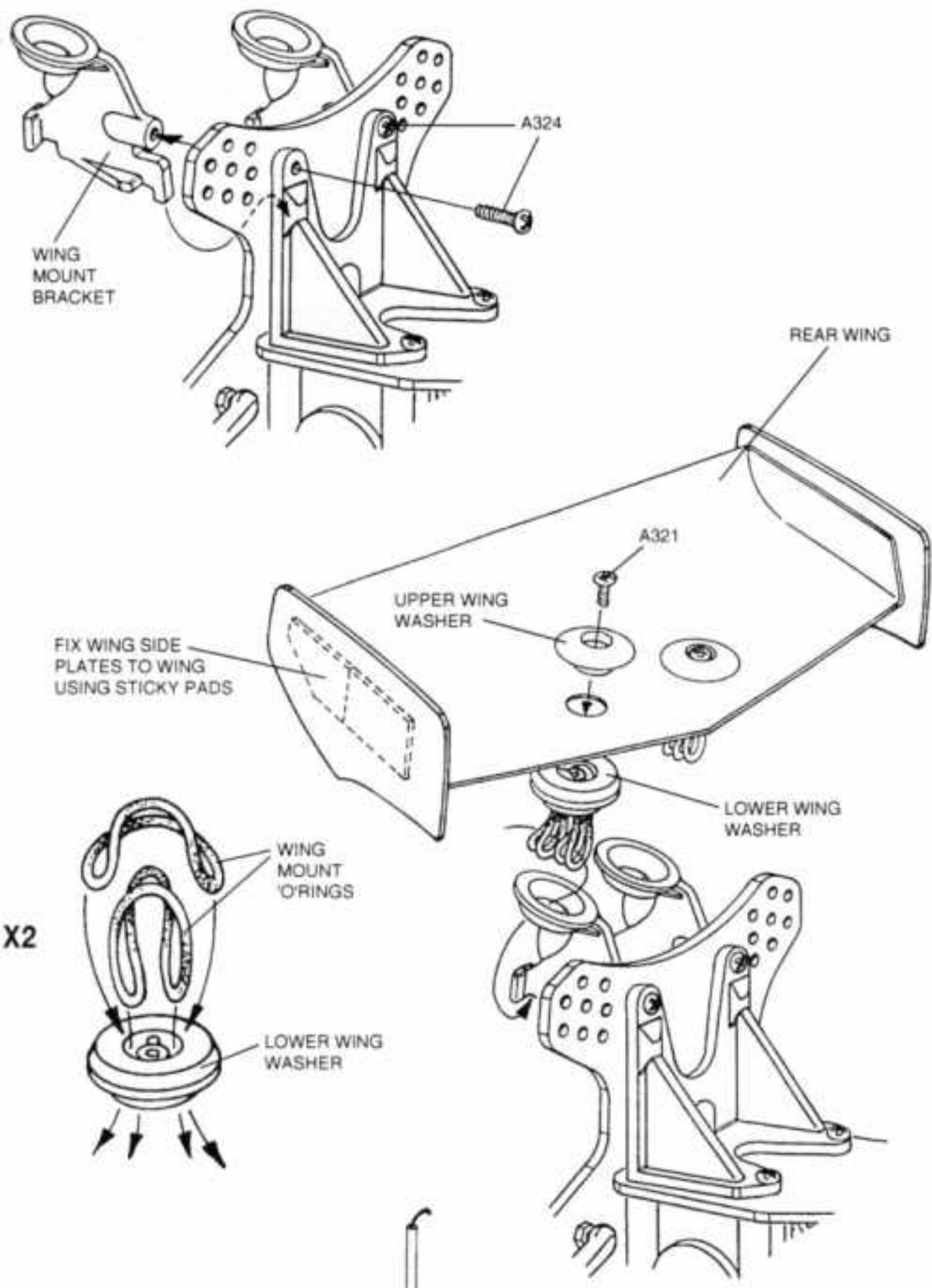

**CONSULT THE INDIVIDUAL INSTRUCTION SHEETS SUPPLIED WITH YOUR OWN RADIO CONTROL EQUIPMENT AND SPEED CONTROLLER WHEN FITTING INTO CAR**

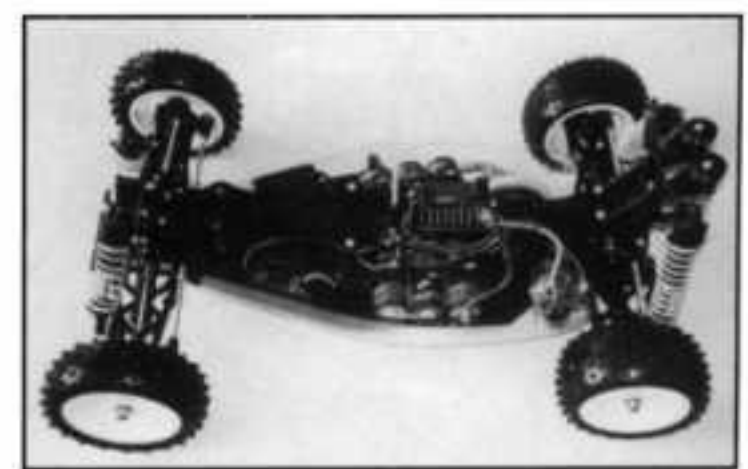
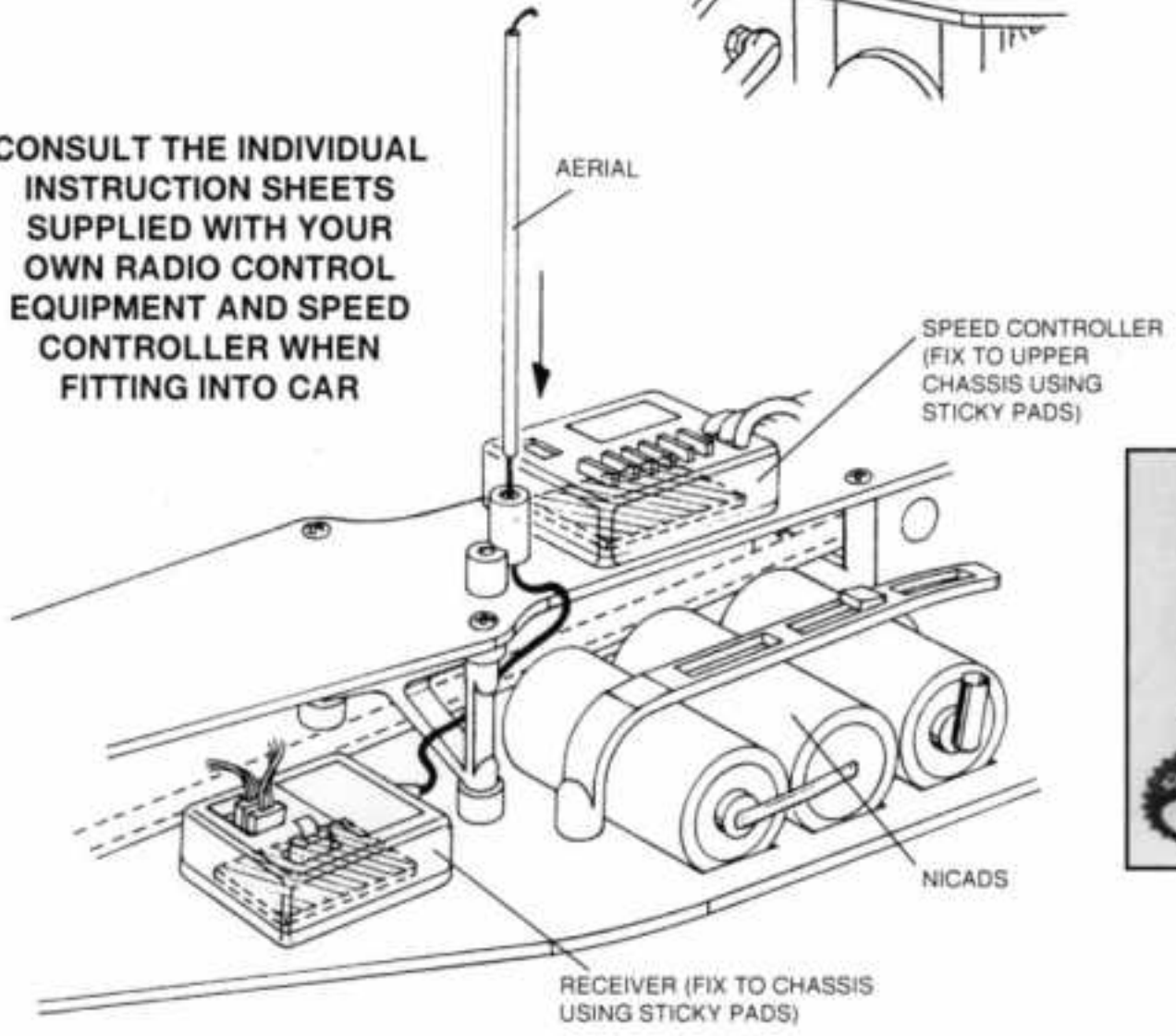

**THIS PHOTO SHOWS A CAR FULLY WIRED UP AND READY TO RUN**

## FITTING SERVO

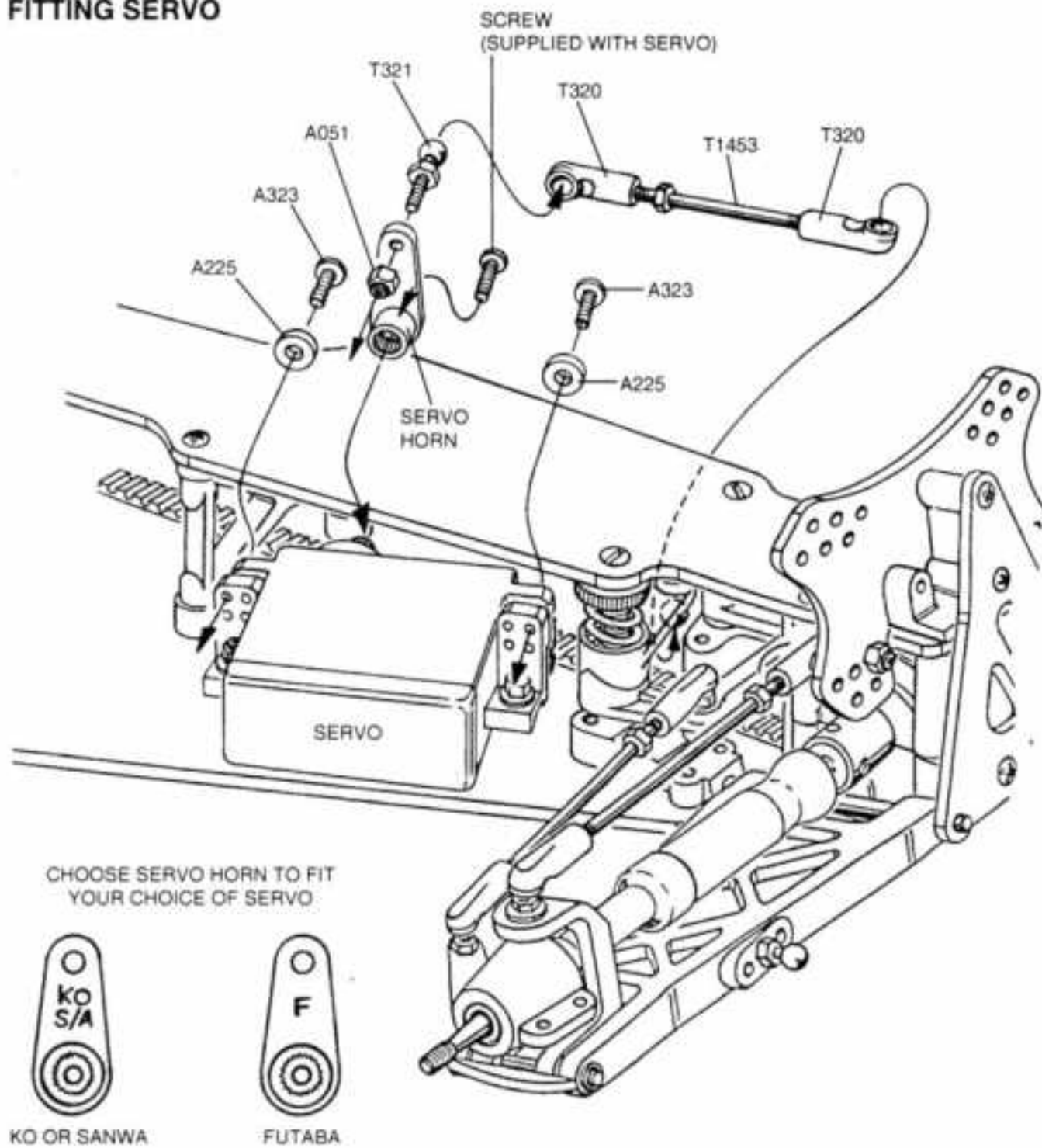

**Schumacher**

**CAT**  
**ZOO**  
THE NEW GENERATION

## FITTING ELECTRICS

### HARDWARE

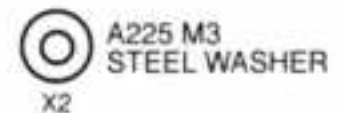
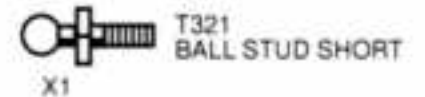
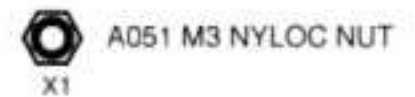
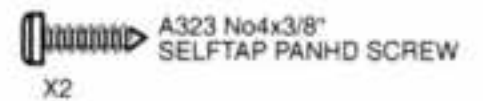
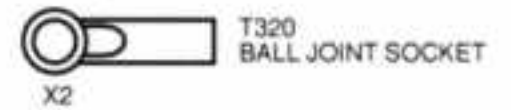

## FITTING MOTOR

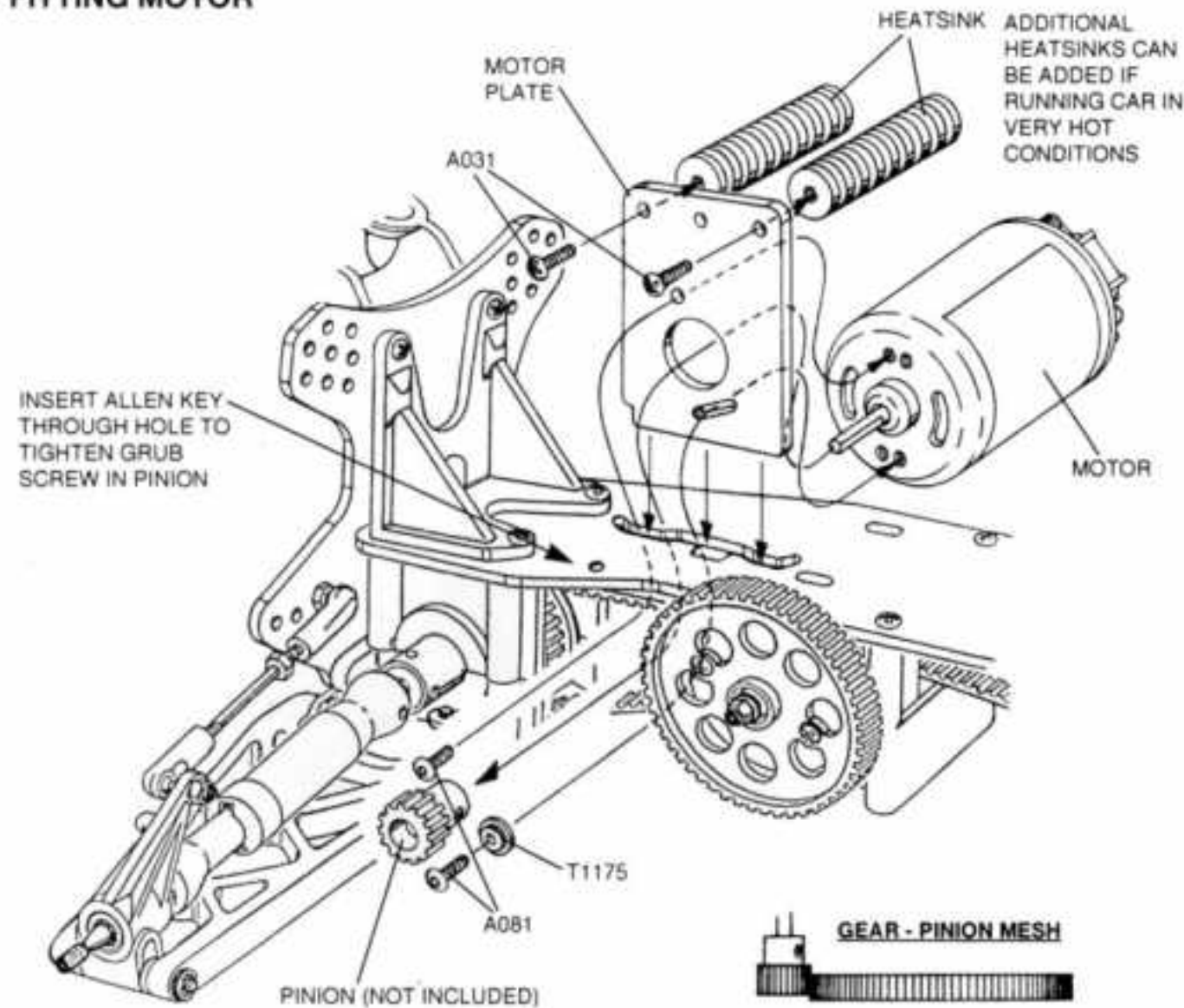

ENSURE THERE IS A SMALL AMOUNT OF PLAY BETWEEN GEARS TO REDUCE DRAG

**SERVICING****REMOVING FRONT SUSPENSION**

REMOVE THE 6 SCREWS SHOWN AND 1 NYLOC NUT. EACH FRONT WISHBONE ASSEMBLY CAN NOW BE REMOVED SEPERATELY

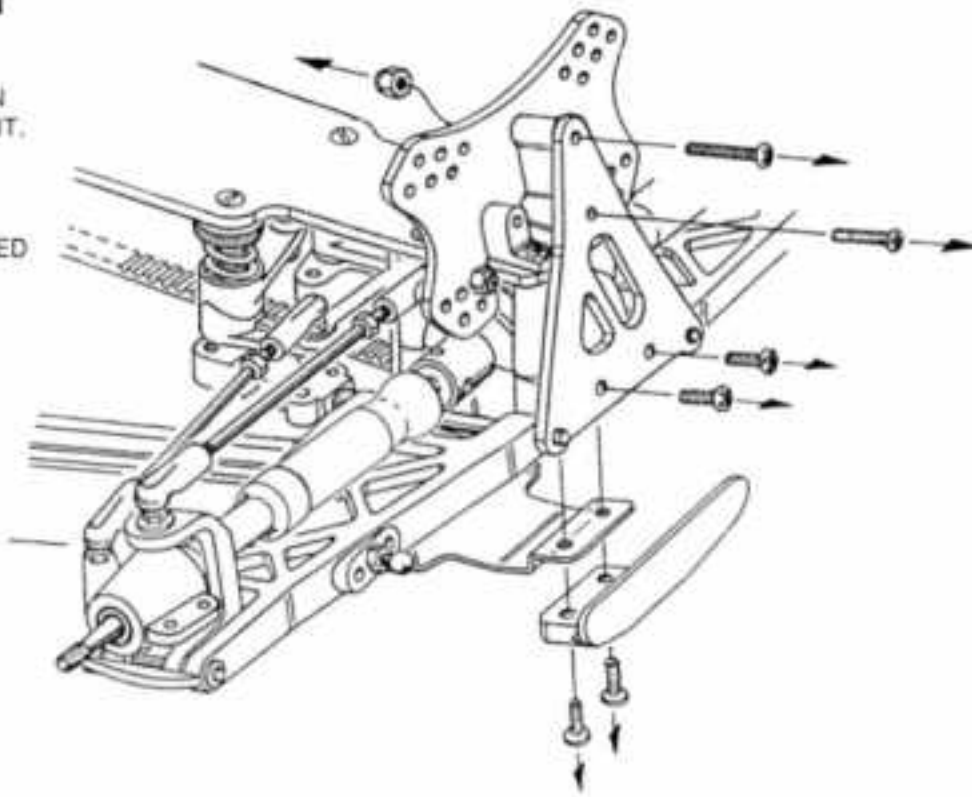
**REMOVING REAR SUSPENSION**

REMOVE THE FRONT 'E'CLIP AND SLIDE OUT PIVOT PIN

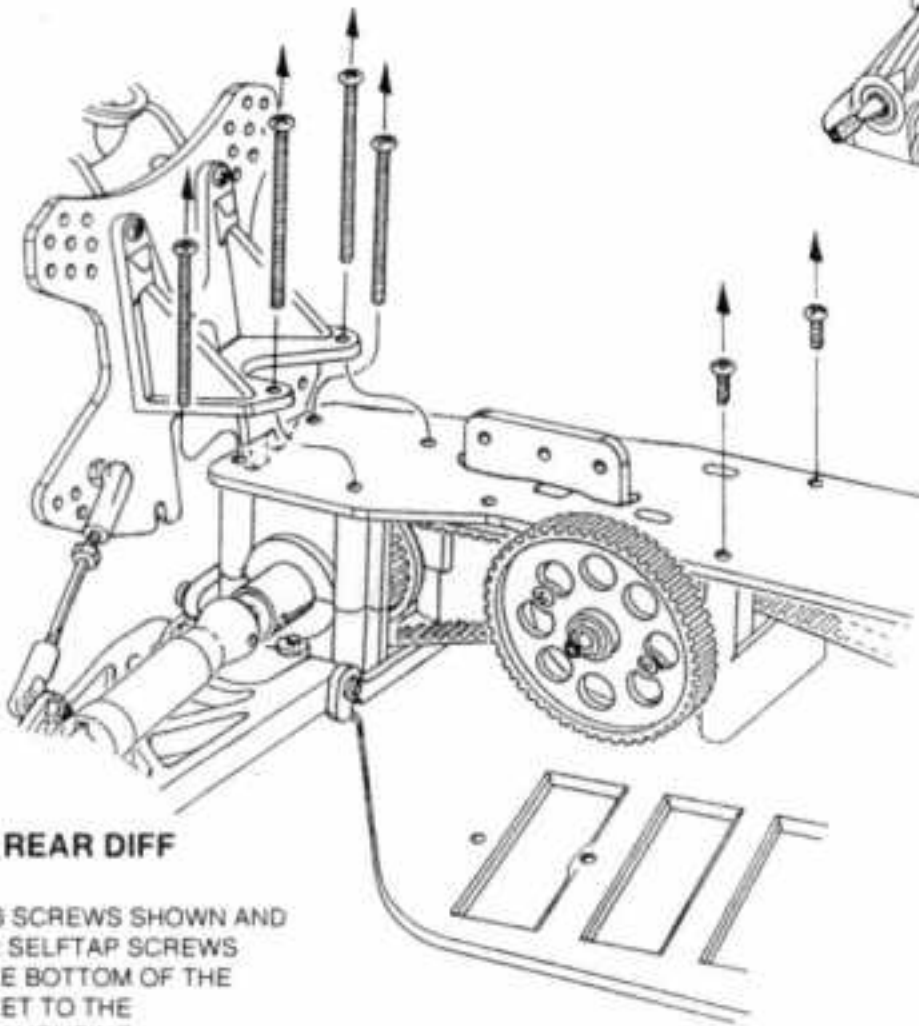
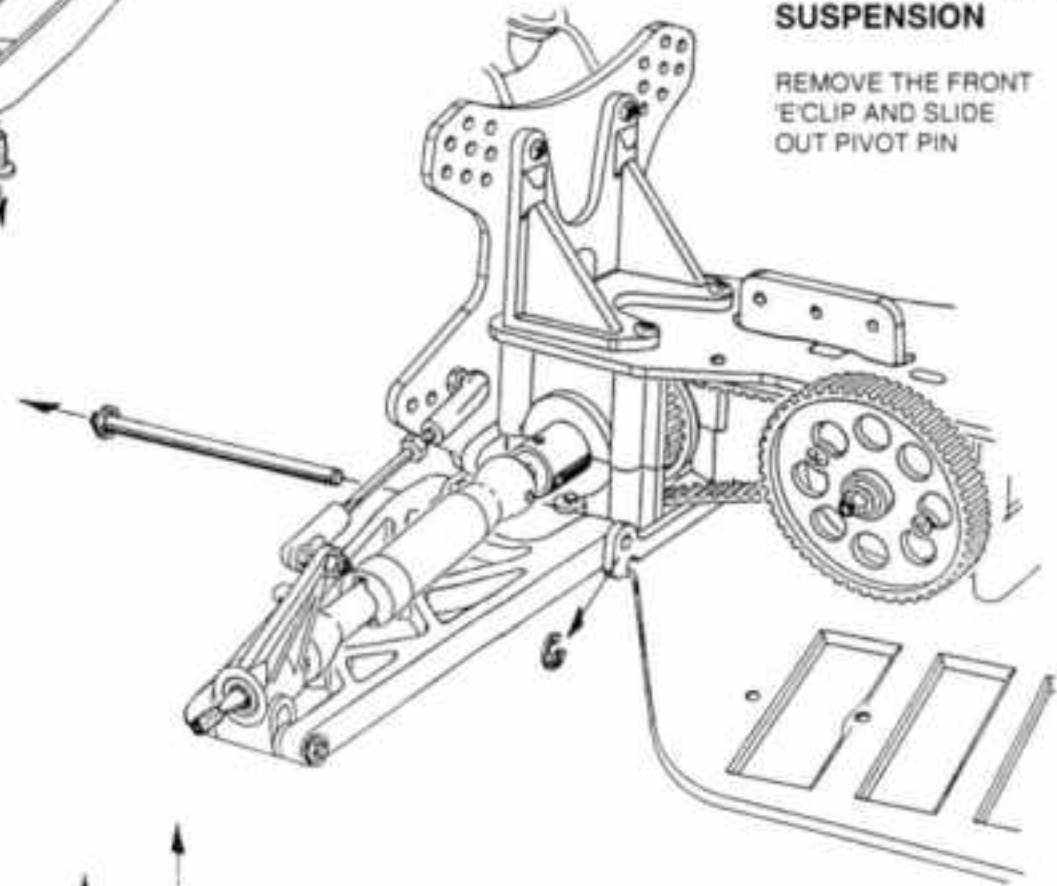
**REMOVING REAR DIFF**

REMOVE THE 6 SCREWS SHOWN AND LOOSEN THE 2 SELFTAP SCREWS THAT HOLD THE BOTTOM OF THE SHOCK BRACKET TO THE TRANSMISSION HOUSING. ALLOW SHOCK BRACKET TO FALL FREE. FLEX TOP CHASSIS UPWARDS. REAR DIFF AND DRIVESHAFTS CAN NOW BE REMOVED.

**REMOVING FRONT DIFF**

REMOVE ALL THE SCREWS SHOWN. ALLOW FRONT SHOCK BRACKET ASSEMBLY TO FALL FREE. FLEX TOP CHASSIS UPWARDS. FRONT DIFF & DRIVESHAFTS CAN NOW BE REMOVED.

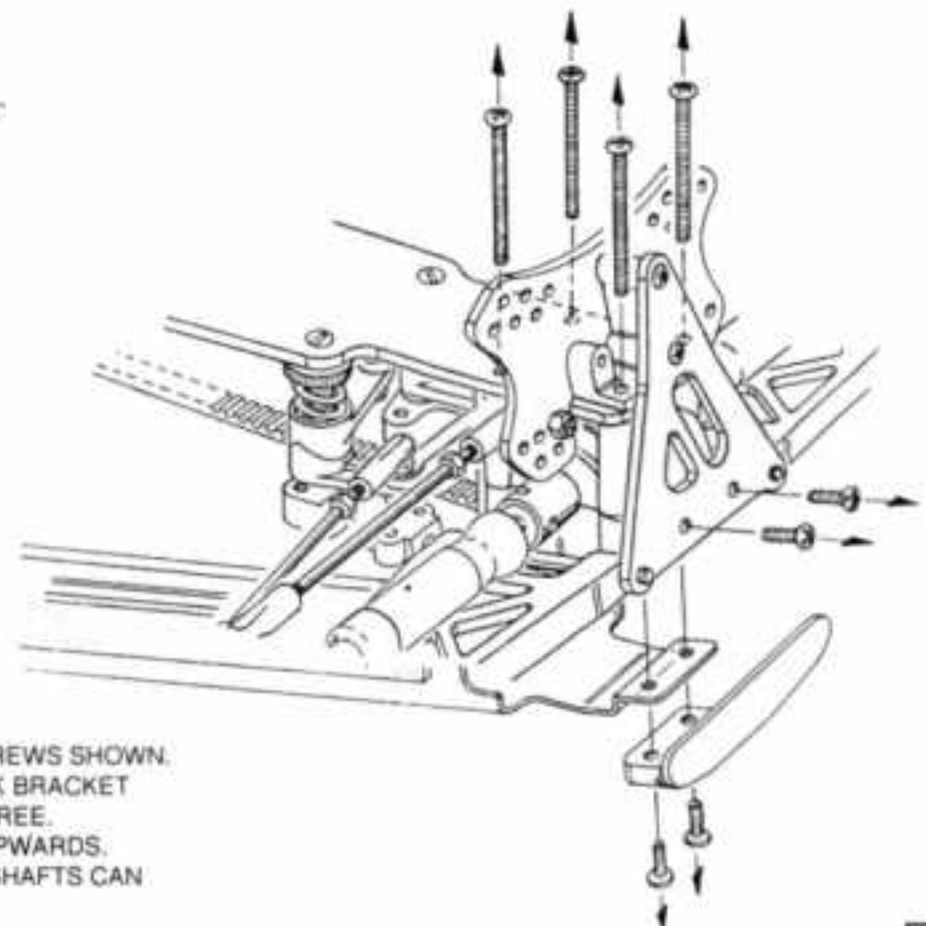



The table below shows the set up as kit build and set ups for certain types of track.  
Use these as starting points.  
Pages 22, 23, 24 and 25 explain in detail how each adjustment affects the cars handling. Use these steps for fine tuning.

On the back cover is a set up sheet which can be photocopied and used to build up a reference record of track conditions and track settings.

**TRACK SETTINGS**

ADJUSTMENT	CAR BUILT AS BOOK	PACKED DIRT -DAMP	MULTI SURFACE, ASTRO TURF & ASPHALT	INDOOR FLAT CARPET	PACKED DIRT -DRY	GRASS
<b>FRONT SUSPENSION</b>						
FRONT CAMBER	-1°	-1°	-2°	-1°	-1°	-2°
FRONT CASTOR	0	0	0	0	+5°	+5°
BUMP STEER SPACER	1.6mm	1.6mm	3.2mm	1.6mm	8mm	8mm
FRONT TOE-IN	STRAIGHT	STRAIGHT	STRAIGHT	STRAIGHT	STRAIGHT	STRAIGHT
FRONT RAKE ANGLE	15°	15°	15°	15°	10°	15°
TOP LINK POSITION	A	D	D	B	D	D
<b>SHOCK ABSORBERS - FRONT</b>						
SPRINGS	YELLOW	GREY	GREY	GREY	YELLOW	YELLOW
OIL	30W	40W	30W	30W	40W	30W
SHOCK POSITION - WISHBONE	MIDDLE (No2)	MIDDLE (No2)	OUTER (No3)	OUTER (No3)	MIDDLE (No2)	MIDDLE (No2)
SHOCK POSITION - TOP	3	1	2	3	6	3
HOLES OPEN IN PISTON	4	4	4	4	4	4
(SUSPENSION STIFFNESS)	6.0	9.0	11.3	11.3	6.0	6.0
(SUSPENSION DAMPING)	18.8	24.5	23.6	23.6	24.5	18.8
<b>REAR SUSPENSION</b>						
REAR CAMBER	-1°	-1°	-2°	0°	-1°	0°
REAR TOE-IN (ACTUAL)	3°	3°	3°	1°	3°	3°
REAR HUB CARRIER PIN LOCATION	LOW	HIGH	LOW	LOW	HIGH	HIGH
TOP LINK POSITION	A	A	A	B	A	A
WHEELBASE	MED	SHORT	MED	LONG	SHORT	SHORT
<b>SHOCK ABSORBERS - REAR</b>						
SPRINGS	YELLOW	GREY	YELLOW	BLUE	YELLOW	YELLOW
OIL	30W	40W	40W	30W	40W	30W
SHOCK POSITION - WISHBONE	MIDDLE (No2)	MIDDLE (No2)	OUTER (No3)	OUTER (No3)	MIDDLE (No2)	MIDDLE (No2)
SHOCK POSITION - TOP	7	6	7	3	6	2
HOLES OPEN IN PISTON	4	4	4	4	4	4
(SUSPENSION STIFFNESS)	8.4	12.6	10.0	20.4	8.4	8.4
(SUSPENSION DAMPING)	26.3	34.2	40.7	31.3	34.2	26.3
<b>TRANSMISSION</b>						
SLIPPER CLUTCH (SLIP DIST)	0.25 metres	0.25 metres	0.25 metres	0.25 metres	0.50 metres	0.25 metres
PINION	SEE GEAR CHART	15 T	18 T	16 T	18 T	16 T
SPUR GEAR	SEE GEAR CHART	95 T	95 T	95 T	95 T	95 T
MOTOR TURN			12 x 2	12 x 2	13 x 3	11 x 2
CELLS POSITION	FORWARD	FORWARD	REARWARD	REARWARD	FORWARD	FORWARD
HEAT SINKS	2	5	3	5	2	3
BODYSHELL CUTOUTS	SIDE & TOP	TOP	SIDE & TOP	SIDE & TOP	SIDE & TOP	SIDE & TOP
<b>TYRES</b>						
FRONT	U6534C	U6566I + F	U6515J + F	U6517L + F	U6566I + F	U6515J + F
REAR	U6532A	U6565H + F	U6516K + F	U6535D + F	U6565H + F	U6516K + F
<b>OPTIONAL EXTRAS</b>						
REAR ANTI-ROLL BAR						
FRONT ANTI-ROLL BAR						

TYRES: F = FOAM INSERT

**FRONT SHOCK BRACKET**

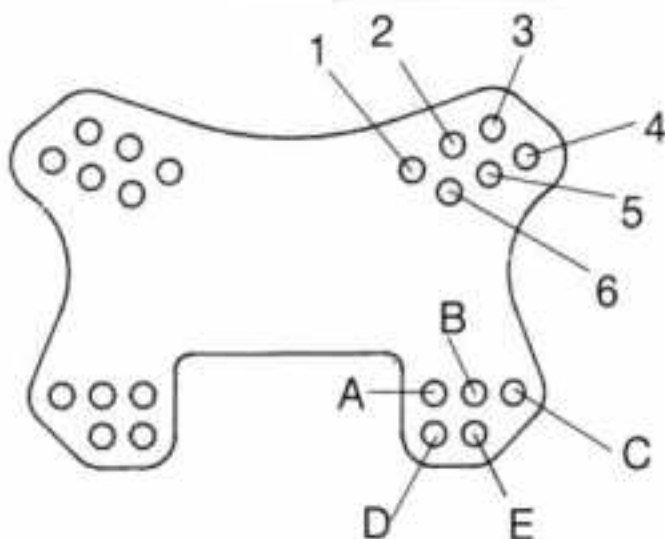

**REAR SHOCK BRACKET**

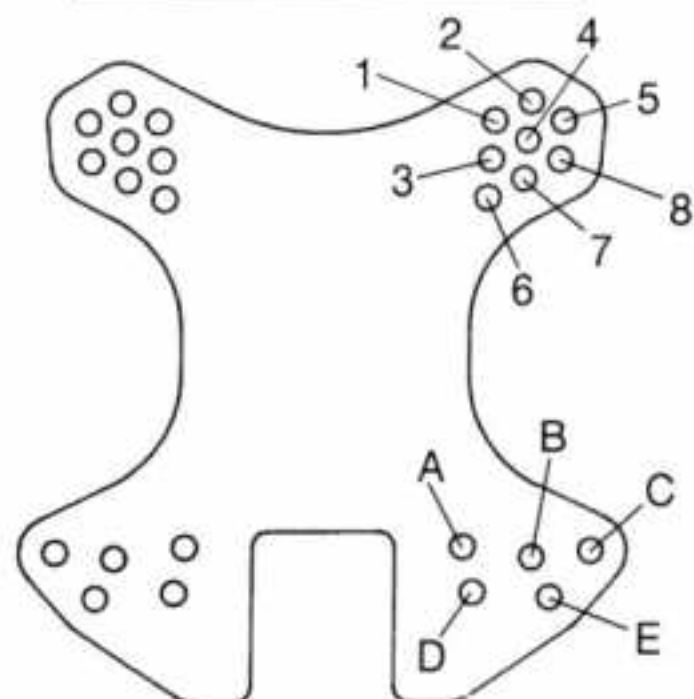

1 Make sure screws are tight, recheck after each race.

2 WHEELBASE

The cars wheelbase can be altered by moving the washers that sit between the rear hub carrier and the wishbone. There are 3 possible settings. Generally the shorter wheelbase gives more rear traction, a longer wheelbase improves steering response.

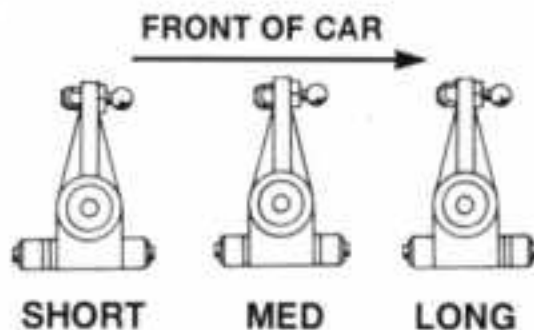

**TRACK SETTINGS**

3 DIFF

If the transmission is correctly built you should hear a clicking sound when you spin the front wheels. If you don't, check layshaft assembly for free movement of oneway dog. If the differentials are correctly built as in the transmission steps they should not need adjusting during racing. Any slip adjustment should be done on the slipper clutch. **DO NOT LOOSEN THE THE DIFF TO ACHIEVE SLIP.** During maintenance when cleaning diffs be careful to reassemble the correct way. If diff does become loose (noticeable by a 'squark' coming from the car when accelerating from standstill) tighten by following steps in Transmission section.

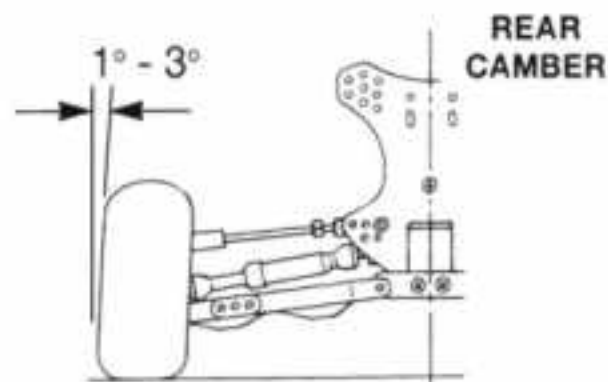

4 REAR CAMBER

The rear wheels should be set at negative camber. This means that the top of the wheels lean inward. Adjustment is carried out by turning the top link. The righthand thread of the link is nearest the hex. Adjust to be the same both sides. Too much negative camber and you will have begin to have less traction.

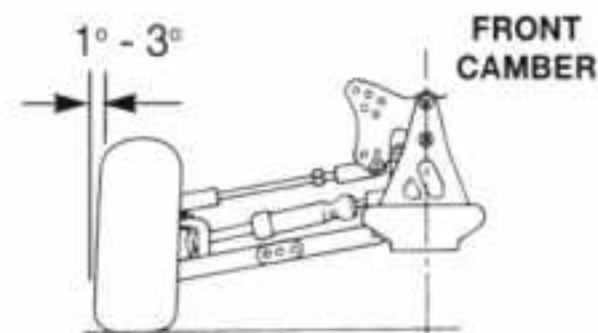

5 FRONT CAMBER

The front wheels should be set at negative camber. Adjust to be the same both sides. Generally the more negative camber, the more steering you will get at high and medium speeds. Too much negative camber and you will begin to have less steering.

6 FRONT TOE IN

The front track rods are adjustable, similar to the suspension top links. Set the front wheels to be parallel to each other when pointing straight ahead. If conditions are slippery add 1 - 2 deg toe-in, this will make the car steer a little less. Toe-out will give more steering at low speed, but may make the car more unstable on corner exit.

- A greater than B = toe-out
- A less than B = toe-in
- A equal to B = parallel (standard setting)

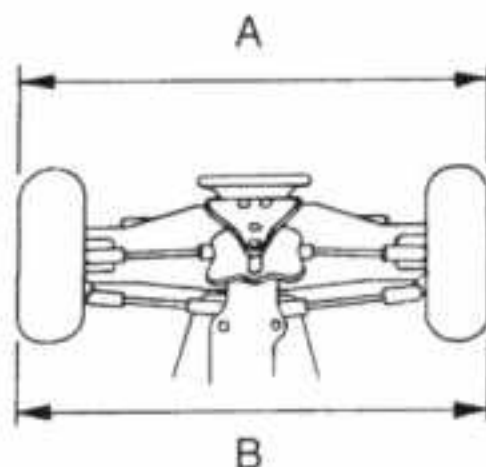

7 REAR TOE IN & OUT BOARD PIVOT PIN LOCATION

The rear hub carriers have inserts which alter the toe in and the height of the pivot pin. Each insert moulding has an arrow marked on it and a number, with or without a degree sign (°). There are 3 different inserts, marked 0, 1 and 2. By putting the inserts in the hub carrier in different ways toe in can be varied from 1° to 5°, and the outboard pivot pin can be high or low. The chart shows the possible settings, dealing with the righthand side only. If the righthand side has an insert **with** a degree sign on it, the lefthand side must have the same value insert **without** a degree sign on it - and vice versa.

INSERT	PIVOT PIN LOCATION	ACTUAL TOE IN
2	LOW	5°
1	LOW	4°
0	LOW	3°
0°	LOW	3°
1°	LOW	2°
2°	LOW	1°
2°	HIGH	5°
1°	HIGH	4°
0°	HIGH	3°
0	HIGH	3°
1	HIGH	2°
2	HIGH	1°

**ENSURE TOE IN AND PIVOT PIN LOCATION ARE THE SAME BOTH SIDES.**

More rear toe in will give more power understeer and more stability and traction at the rear, recommended for tracks with low traction. The outboard pivot pin :  
On low grip tracks run with the pivot pin high (close to the axle). This will give more stability and be better through bumpy corners.  
On high grip tracks run with the pivot pin low. This reduces the tendency of the car to understeer.

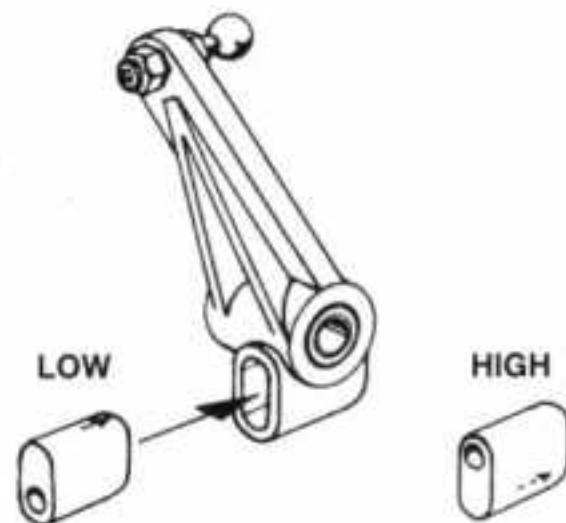

8 ROLL CENTRE

Altering the rear top link position changes the roll centre. Different length turnbuckles need to be used depending on the hole chosen. Using a shorter link in one of the lower holes will increase steering response.

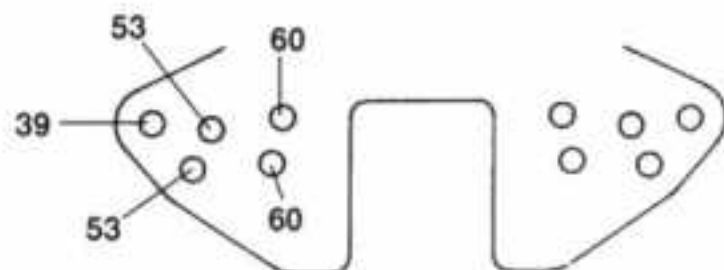



**TRACK SETTINGS**

**SPRING SPACERS / RIDE HEIGHT**

Spring spacers only adjust the ride height, not the suspension stiffness. Adjust the spring spacers and shock positions so that your required ride height is achieved but always maintaining some droop travel.

**SUSPENSION TUNING**

When setting up your car for handling the choice of damping, spring rate and of mounting holes for the shock absorbers are all very important. These factors combine to give you 'Suspension Stiffness' and 'Damping Stiffness' which you must consider when working on the suspension settings of your car. The 'Suspension Stiffness' tables show what is achieved with various combinations of spring rate and wishbone holes. The 'Damping Stiffness' tables show what is achieved with various combinations of piston holes and wishbone holes. The top shock mounting position should be chosen primarily to give the required ride height and is not very significant as far as 'Stiffness' and 'Damping' are concerned. However, as the shock absorber angle becomes more extreme the effective 'Stiffness' and 'Damping' are reduced slightly.

**FRONT**

SUSPENSION STIFFNESS	SPRING	WISHBONE HOLE No
22.7 HARD	BLACK	3
18.1	BLACK	2
15.1	BLUE	3
13.9	BLACK	1
12.0	BLUE	2
11.3	GREY	3
9.3	BLUE	1
9.0	GREY	2
7.6	YELLOW	3
7.0	GREY	1
6.0	YELLOW	2
5.7	WHITE	3
4.6	YELLOW	1
4.5	WHITE	2
3.5 SOFT	WHITE	1

WISHBONE HOLE	No OF HOLES IN PISTON	DAMPER STIFFNESS AT WHEEL			
		OIL WEIGHT			
		10W	20W	30W	40W
3	1	34.4	54.0	75.6	111
	2	32.9	50.4	68.7	108
	3	19.4	36.0	58.2	80.4
	4	9.8	14.0	23.6	30.7
2	1	27.4	43.0	60.2	88.5
	2	26.2	40.1	54.7	86.0
	3	15.4	28.7	46.3	64.0
	4	7.8	11.1	18.8	24.5
1	1	20.5	33.1	46.4	68.2
	2	20.0	30.9	42.2	66.3
	3	11.9	22.1	35.7	49.4
	4	6.0	8.6	14.5	18.9

**FRONT**

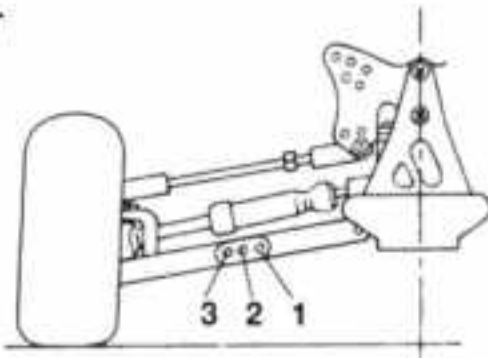

**REAR**

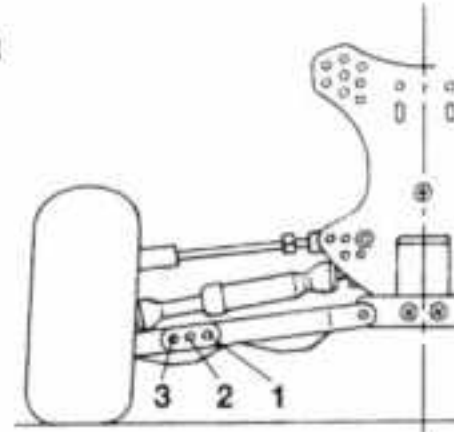

**REAR**

SUSPENSION STIFFNESS	SPRING	WISHBONE HOLE No
20.4 HARD	BLUE	3
16.8	BLUE	2
15.0	GREY	3
13.9	BLUE	1
12.6	GREY	2
10.5	GREY	1
10.0	YELLOW	3
8.4	YELLOW	2
7.5	WHITE	3
6.9	YELLOW	1
6.3	WHITE	2
5.2 SOFT	WHITE	1

WISHBONE HOLE	No OF HOLES IN PISTON	DAMPER STIFFNESS AT WHEEL			
		OIL WEIGHT			
		10W	20W	30W	40W
3	1	45.5	71.6	100.2	147.4
	2	43.6	66.8	91.1	143.1
	3	25.7	47.7	77.0	106.6
	4	13.0	18.6	31.3	40.7
2	1	38.3	60.1	84.2	123.8
	2	36.6	56.1	76.5	120.3
	3	21.6	40.0	64.8	89.6
	4	10.9	15.6	26.3	34.2
1	1	31.6	49.7	69.6	102.4
	2	30.3	46.4	63.3	99.4
	3	17.8	33.1	53.5	74.1
	4	9.0	12.9	21.7	28.3

NOTE : AMBIENT TEMPERATURE AFFECTS DAMPER STIFFNESS

20w oil at 50° F (10° C) is approximately the same as 30w oil at 80° F (27° C)

See chart on page 21 for actual set ups. Use these tables for fine tuning.

Use these tables every time you change the suspension settings and record the settings and results for future use. Experiment to find the settings that suit your driving style and the prevailing track conditions.

NOTE: All Schumacher springs are colour coded. The colour denotes the spring rate. There are three sizes S (short), M (medium) L (long)

RATE	COLOUR
1.5	WHITE
2	YELLOW
3	GREY
4	BLUE
6	BLACK



**TRACK SETTINGS**

**10 FRONT CASTOR - OPTIONAL EXTRA (SPEED SECRETS)**  
 The front castor is the angle of the front king pin in relation to a perpendicular line to the ground. When running different castor angles and top link positions a washer(s) will need to be added below the steering trackrod ball stud at the wheel to eliminate bump steer. (Bump Steer Kit available - Speed Secrets)

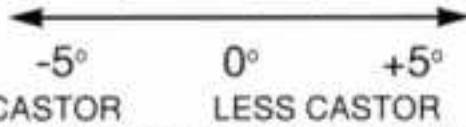

With more castor car is a little more stable coming out of corners and gives more high speed steering. With less castor the car has more low speed steering and sharper 'turn in'.

**11 FRONT RAKE ANGLE - OPTIONAL EXTRA (SPEED SECRETS)**  
 The front rake angle can be changed by changing the front shock brace. The kit comes with a brace which gives a rake angle of 15°. There are 2 other braces available which will give front rake angles of 10° and 20°. For most conditions 15° is generally preferred. However, other rake angles may be more suitable to your driving style and the track conditions - experiment !

**12 TYRES**  
 The front and rear tyres in the kit will give safe predictable handling for most conditions. However, Schumacher CAT range of tyres offer a wide range of options to cover all extremes of operating conditions. The spikes on the tyres may be cut to adjust the handling. For the full range of Schumacher tyres see list on centre pages.

**13 GEAR RATIO CHART - FOR 5 MINUTE RACE USING 1700 mAh NICADS**

PINION	SPUR GEAR	OVERALL RATIO	APPROX MOTOR WIND
28	86	6.14	27 T
28	89	6.36	
27	86	6.37	
27	89	6.59	
26	86	6.62	
26	89	6.85	
25	86	6.88	
25	89	7.12	20 T
25	92	7.36	
24	86	7.17	
24	89	7.42	19 T
24	92	7.67	
23	86	7.48	
23	89	7.74	
23	92	8.00	17 T
22	86	7.82	
22	89	8.09	
22	92	8.36	16 T
22	95	8.63	15 T
21	86	8.19	
21	89	8.48	
21	92	8.76	
21	95	9.05	

MILD MOTOR

PINION	SPUR GEAR	OVERALL RATIO	APPROX MOTOR WIND
20	86	8.60	
20	89	8.90	
20	92	9.20	15 T
20	95	9.50	
19	86	9.05	
19	89	9.37	
19	92	9.68	
19	95	10.00	14 T
18	89	9.89	
18	92	10.22	
18	95	10.55	
17	89	10.47	13 T
17	92	10.82	
17	95	11.18	
16	89	11.13	12 T
16	92	11.50	
16	95	11.86	
15	92	12.27	11 T
15	95	12.67	

HOT MOTOR

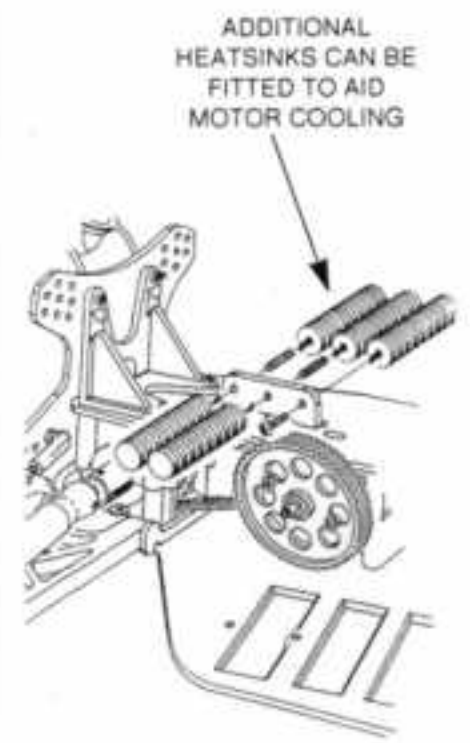

**14 LUBRICATION**  
 All bearings must be lubricated, especially during wet weather. Always remove bearings and clean after running in wet conditions. Plastic parts should NOT be lubricated. Only use silicone grease inside the differential and only use axle grease in the thrust races.

**15 GENERAL**  
 In general the car should understeer, - this means the front wheels slide more than the rear wheels during cornering. You can get this by cutting the spikes of the front tyres down. It helps to have two or three sets of front tyres with different levels of spikes to test for the best option. Run the lowest ride height that track conditions allow - a low car always corners better than a high car. Use the softest damper settings that stop the wheels from bouncing. It is easy to over damp the car and cause bouncing at high speed.



# SET UP SHEET

(CIRCLE THE SETTINGS USED)

DRIVER:

TRACK CONDITIONS:

## FRONT SUSPENSION

RAKE	10°	15°	20°				
CASTOR	0°	+5°	-5°	+8°	-8°	+2°	+3°
TOE-IN	-1°	-2°	-3°	0°	+1°	+2°	+3°

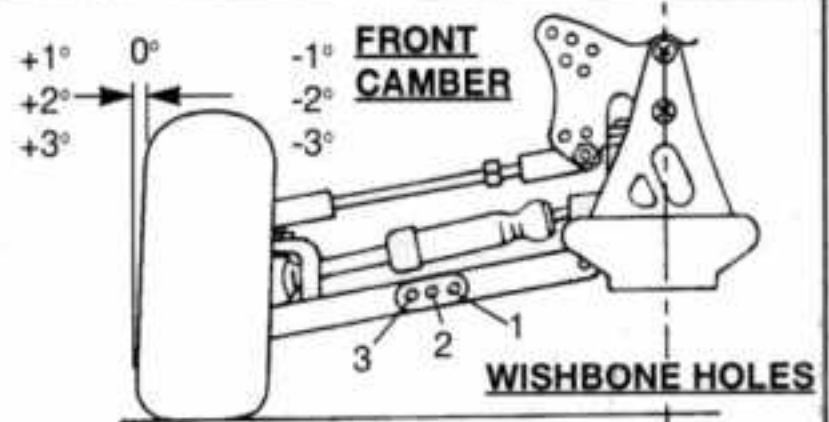

### FRONT SHOCK BRACKET

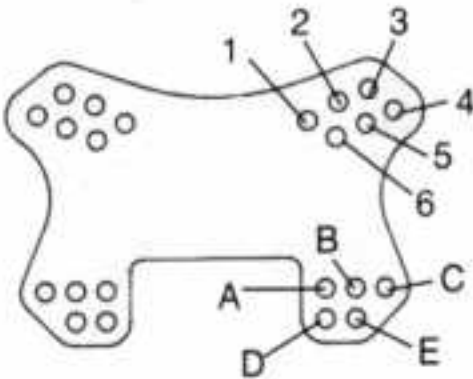

### SHOCKS - FRONT

OIL	10W	20W	30W	40W	50W	60W	70W	80W
HOLES OPEN	1	2	3	4				
VALVED	YES	NO						
SPRINGS	WHITE	YELLOW	GREY	BLUE	BLACK			
SPACERS								mm

## REAR SUSPENSION

TOE-IN INSERT	-1°	-2°	0°	+1°	+2°	(ACTUAL TOE-IN = _____, 0° INSERT = 3° ACTUAL TOE-IN)
OUTBOARD PIVOT PIN		HIGH	LOW			

### REAR CAMBER

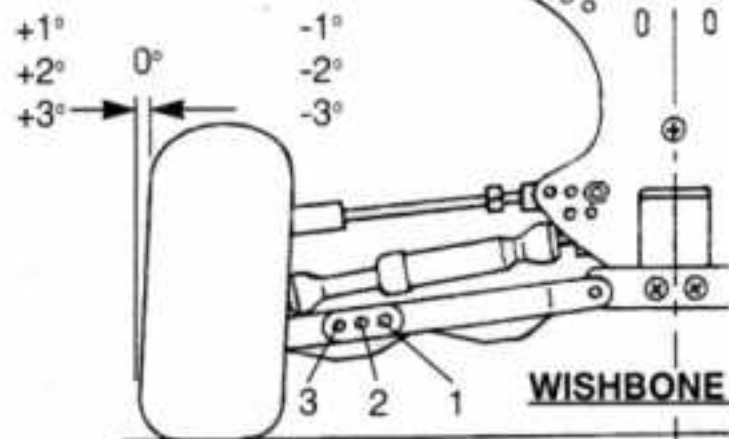

### REAR SHOCK BRACKET

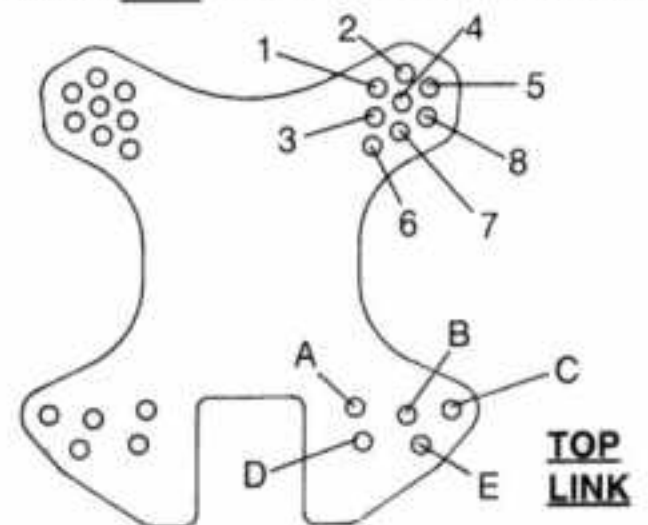

### WHEELBASE



### SHOCKS - REAR

OIL	10W	20W	30W	40W	50W	60W	70W	80W
HOLES OPEN	1	2	3	4				
VALVED	YES	NO						
SPRINGS	WHITE	YELLOW	GREY	BLUE	BLACK			
SPACERS								mm

## TRANSMISSION & CHASSIS

CHASSIS - CELLS	FORWARD	REAR	CELLS - TYPE .....
SPUR GEAR	89T 92T	95T 98T	
PINION	15T 16T	17T 18T	19T 20T 21T 22T
HEATSINKS	1 2	3 4	5 OTHERS
SLIPPER (SLIP DIST)	0.25m	0.50m	0.75m
DRIVESHAFTS	ROLLER	PLAIN	
MOTOR TYPE / WIND .....			SERVO .....
RECEIVER .....			SPEED CONTROLLER .....

### TYRES

FRONT	U.....	FOAMS - YES/NO	FRONT HEX DRIVES - WIDE	NARROW
REAR	U.....	FOAMS - YES/NO	REAR HEX DRIVES - WIDE	NARROW

BODYSHELL CUT OUTS	TOP DUCT	SIDE DUCT	OTHERS	WING TYPE.....
--------------------	----------	-----------	--------	----------------