

# **Schumacher**



## **INSTRUCTION MANUAL**

In line with our policy of continuous development the exact specification of the kit may vary.  
**MISSING OR DEFECTIVE PARTS**  
In the unlikely event of problems with your new kit you should contact the model shop where you purchased, quoting part number, bag number and batch number for both the bag and the kit.

<b>CONTENTS</b>	<b>PAGE</b>
CHASSIS -----	1
REAR SUSPENSION -----	2
DRIVESHAFTS -----	3
TRANSMISSION -----	4 - 5
FRONT SUSPENSION -----	6 - 10
SHOCK ABSORBERS -----	11 - 13
WHEELS & TYRES -----	14
BODYSHELL -----	15
BUMPER & UNDERTRAY -----	16
REAR WING & AERIAL -----	17
FITTING ELECTRICS -----	18
SERVICING CAR -----	19
SERVICING DIFFERENTIALS -----	20 - 21
TRACK SETTINGS -----	22 - 25

**SCHUMACHER RACING PRODUCTS**  
71 - 73 Tenter Road  
Moulton Park  
Northampton  
NN3 6AX  
ENGLAND

**SCHUMACHER USA**  
6302 Benjamin Road  
Suite 404  
Tampa  
Florida 33634  
USA

## IMPORTANT SAFETY NOTES

1. This product is not suitable for children under 14 years of age unless supervised by an adult.
2. Select an area for assembly that is away from reach of small children. The parts are small and can be swallowed by children causing choking and possible internal injuries.
3. Shock fluids, grease and adhesives should be kept out of childrens reach. They are not toxic, but were not intended for human consumption.
4. Exercise care when using any hand tools, sharp instruments and power tools during construction.
5. Carefully read all manufacturers warnings and cautions for any glues or paints that may be used for assembly purposes.



Points where grease should be applied.  
(It will reduce friction and assure smooth movement.)



Points where oil should be applied  
(Light machine oil, 3 in 1 or similar.)

*Do not use excessive force when tightening the self-tapping screws, or you may strip the thread in the plastic. It is recommended to stop tightening it when the threaded part on the screw goes into the plastic part and you feel some resistance from the tightening.*

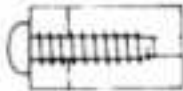

Good

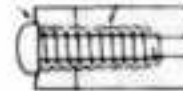

Over tighten and may strip the thread in the plastic

## ELECTRICAL ITEMS REQUIRED

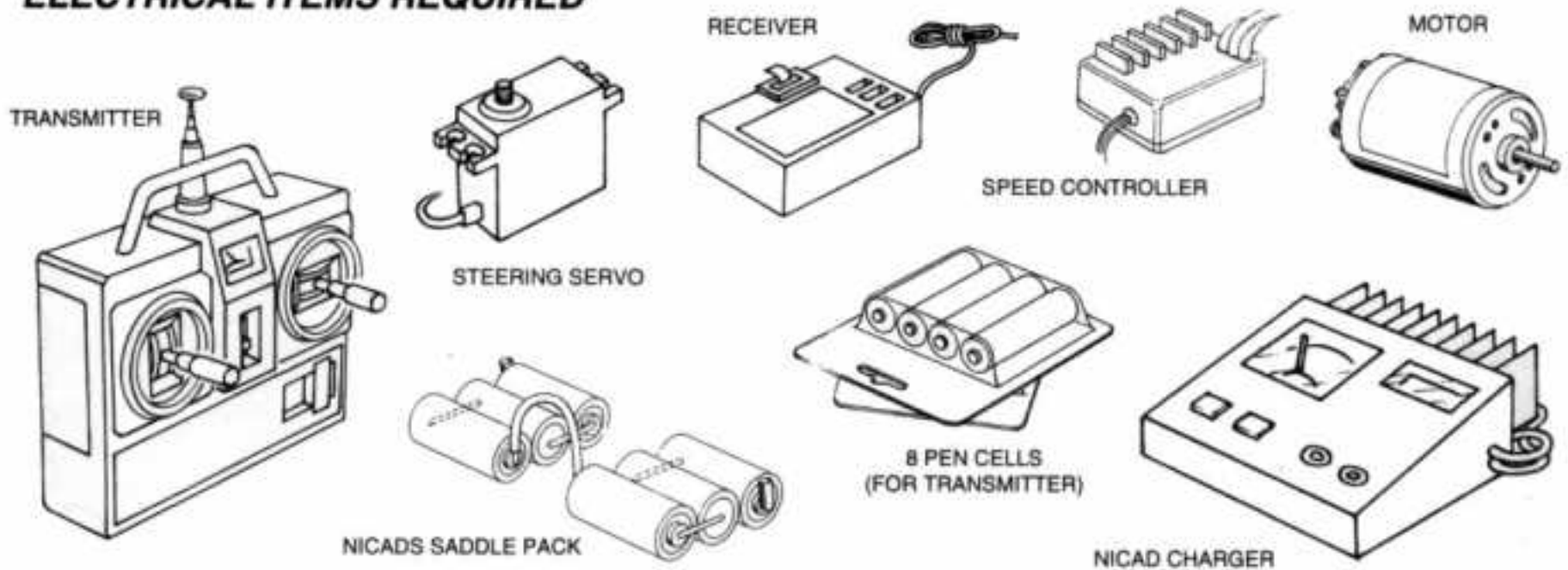

**FOR BEST PERFORMANCE, IT IS VERY IMPORTANT THAT GREAT CARE IS TAKEN TO ENSURE THE FREE MOVEMENT OF ALL PARTS.**

## TOOLS REQUIRED

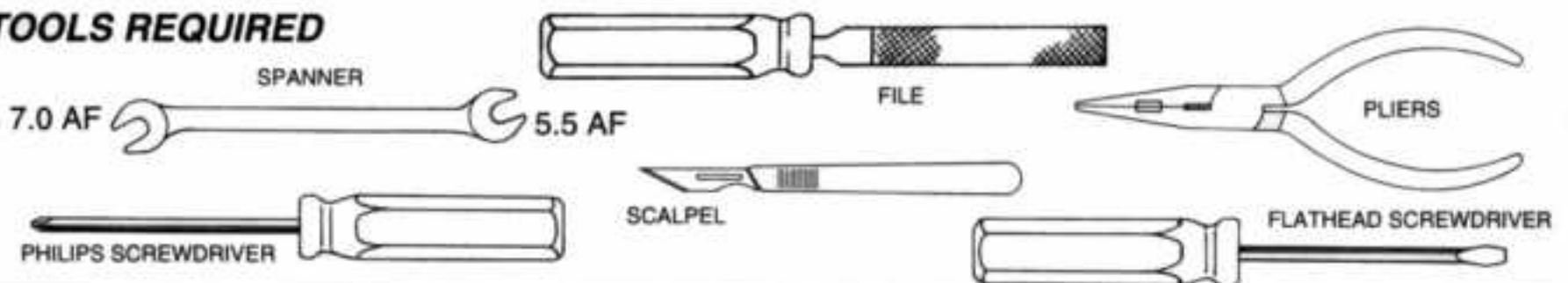

## MATERIALS REQUIRED

Silicone oil for shock absorbers  
Polycarbonate paint for bodyshell

## RULER INCHES & MILLIMETRES

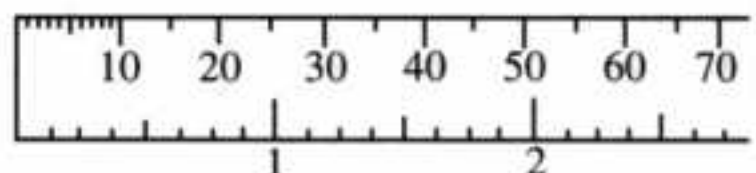

1

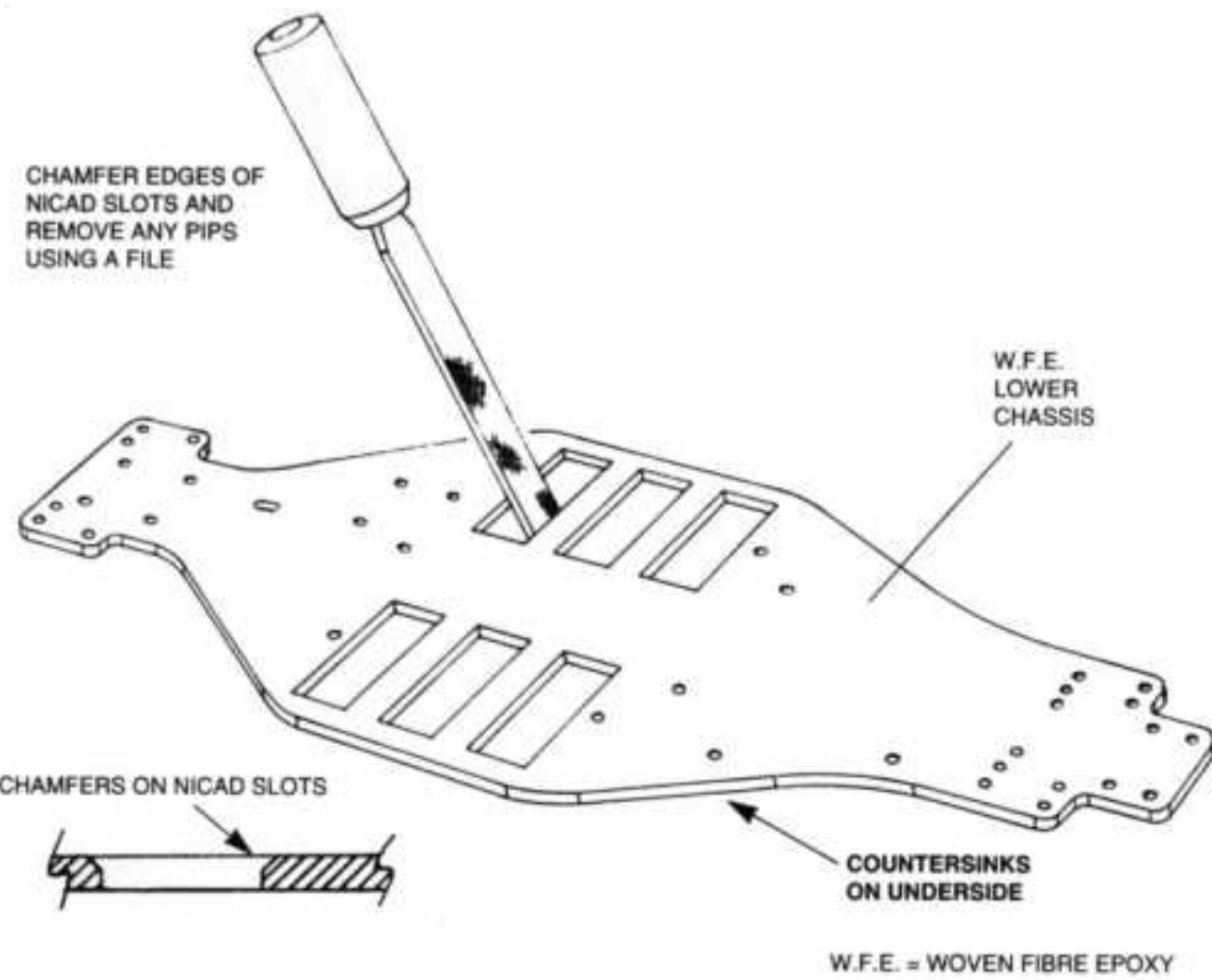

CHAMFER EDGES OF NICAD SLOTS AND REMOVE ANY PIPS USING A FILE



**CHASSIS**

**BAG 1**

**HARDWARE**

- A**  X2  
M3 x 12mm CSK SCREW
- B**  X4  
M3 NYLOC NUT
- C**  X2  
M3 STEEL WASHER
- D**  X4  
No4 x 3/8" SELFTAP CSK SCREW
- E**  X2  
M3 x 8mm CSK SCREW

2

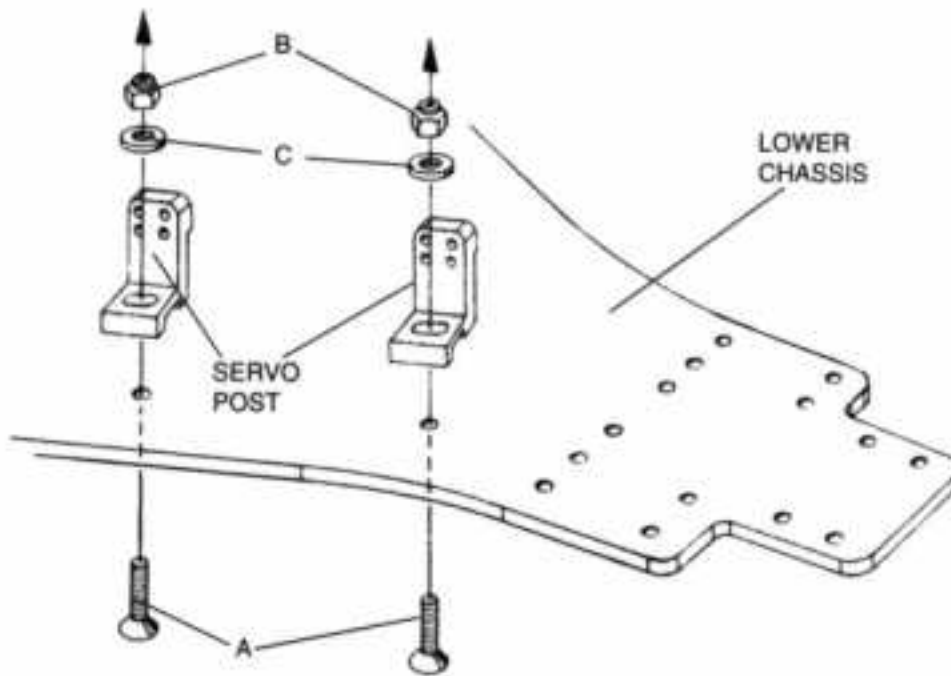

3

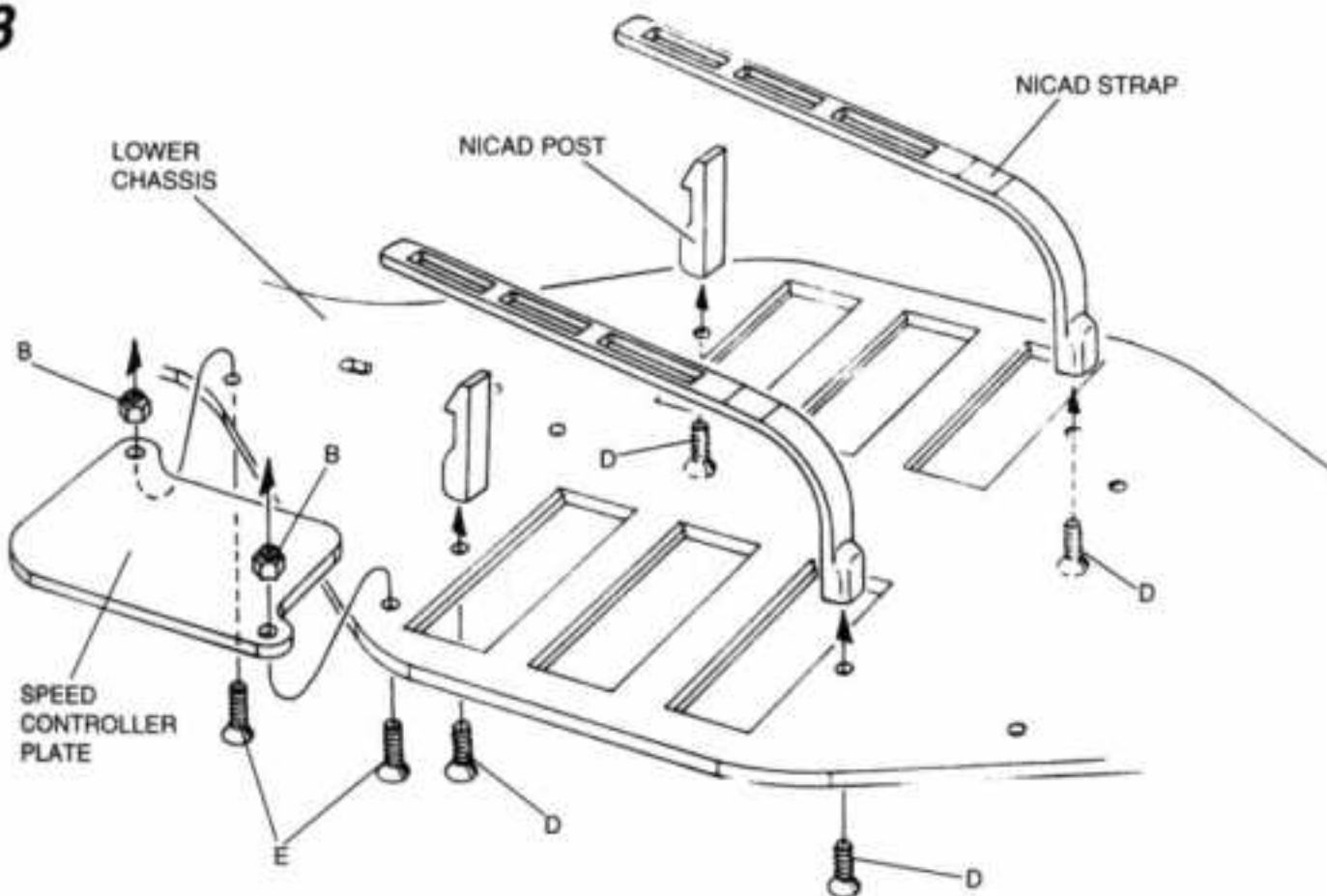

1

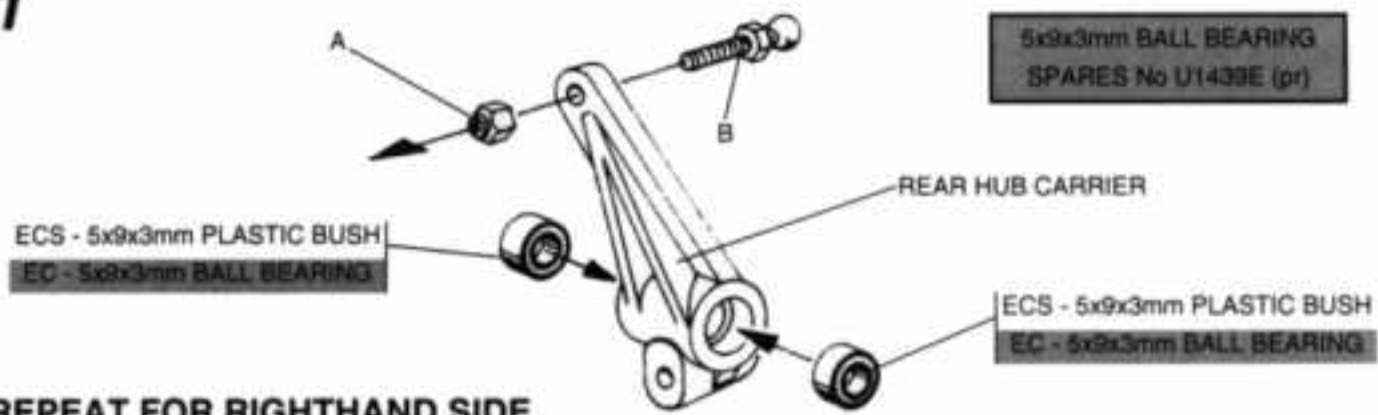

REAR SUSPENSION

BAG 2

HARDWARE

2

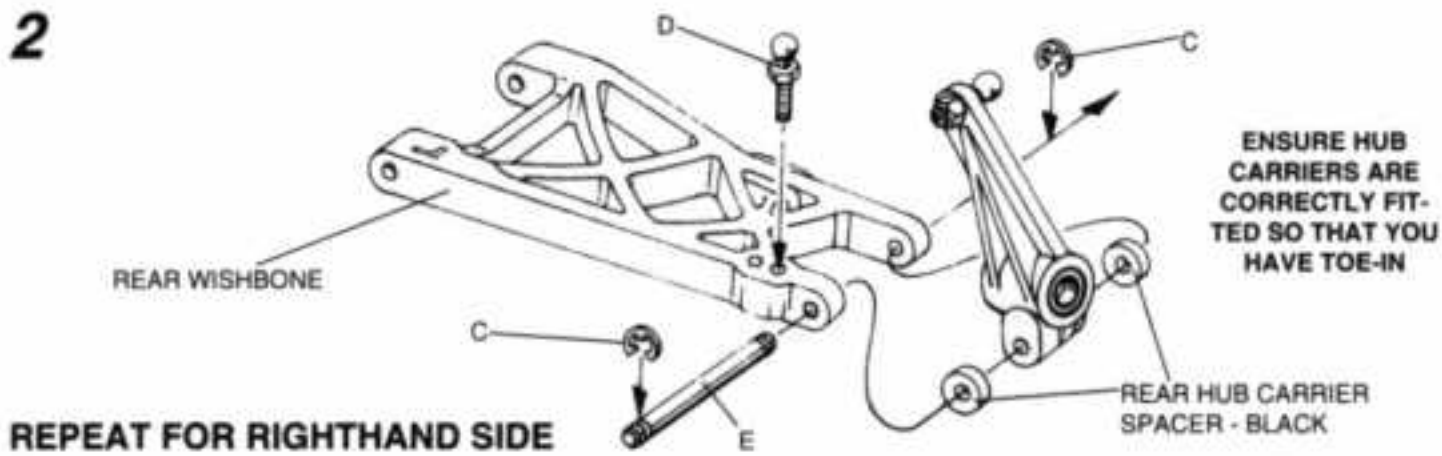

3

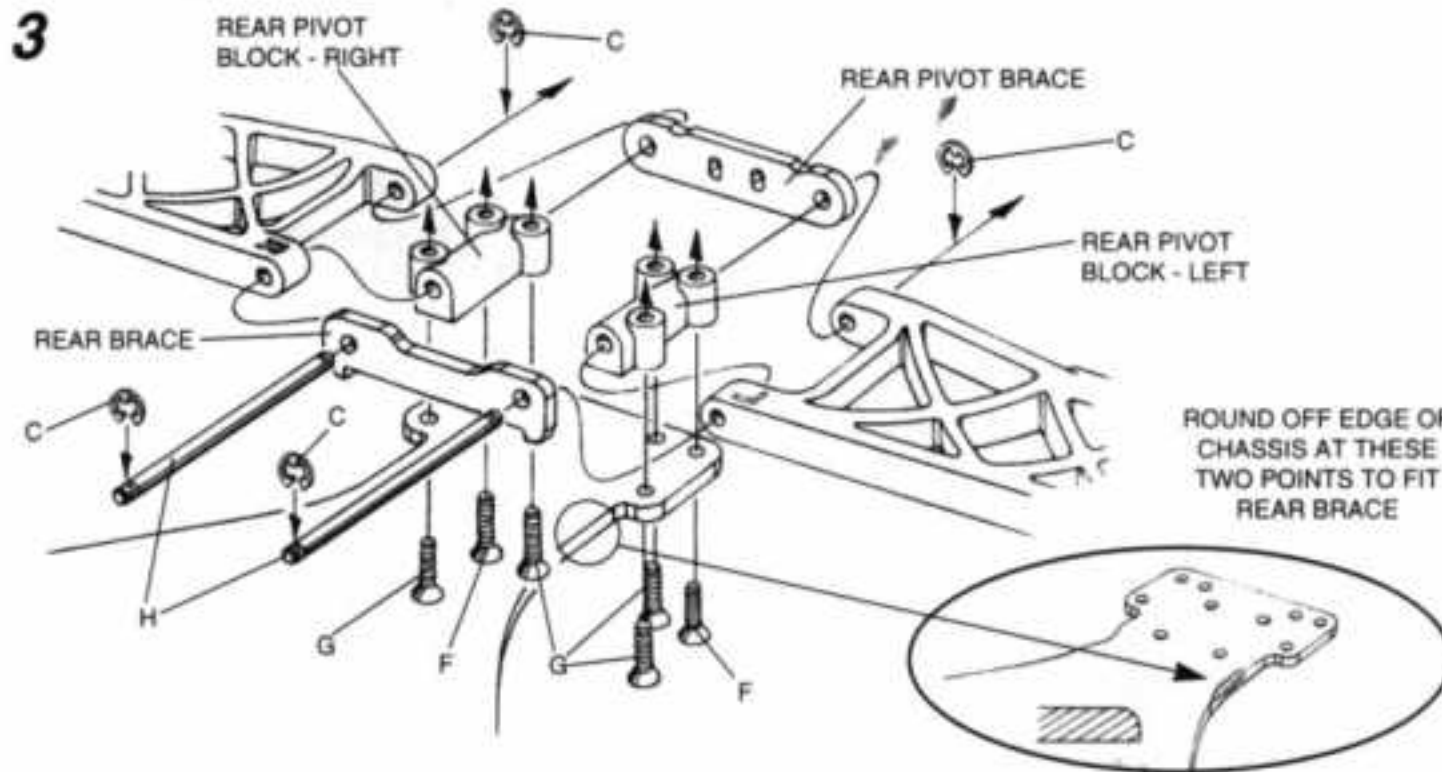

4

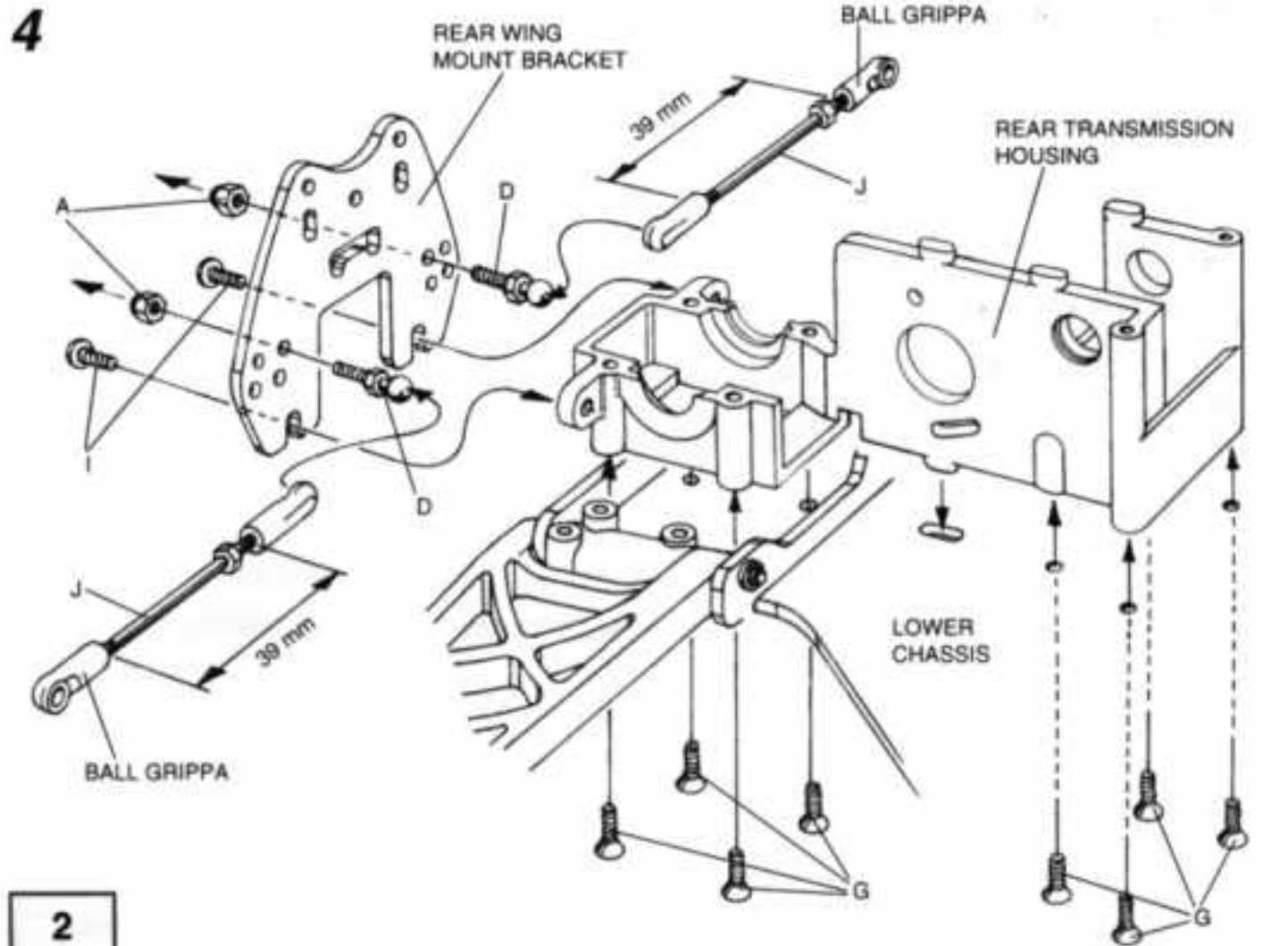

- A  X4  
M3 NYLOC NUT
- B  X2  
BALL STUD LONG
- C  X8  
'E' CLIP
- D  X4  
BALL STUD SHORT
- E  X2  
29mm LONG 1/8" PIVOT PIN
- F  X2  
M3 x 8mm CSK SCREW
- G  X12  
No4 x 3/8" SELFTAP CSK SCREW
- H  X2  
48mm LONG 1/8" PIVOT PIN
- I  X2  
No4 x 1/4" SELFTAP PANHEAD SCREW
- J  X2  
M3 x 53mm TURNBUCKLE

# 1 CO-AXIAL DRIVESHAFTS

**ASSEMBLE ONE DRIVESHAFT AT A TIME**

**X4**

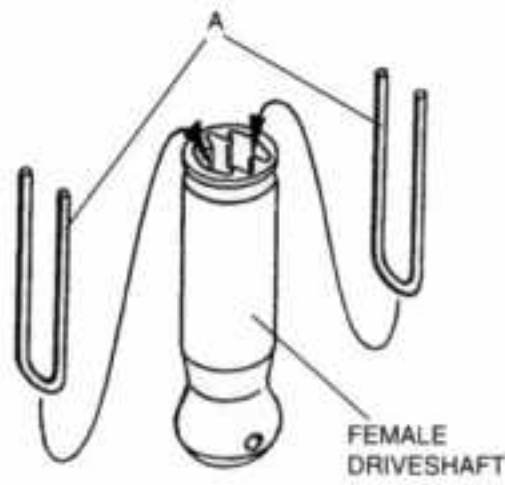

**2**

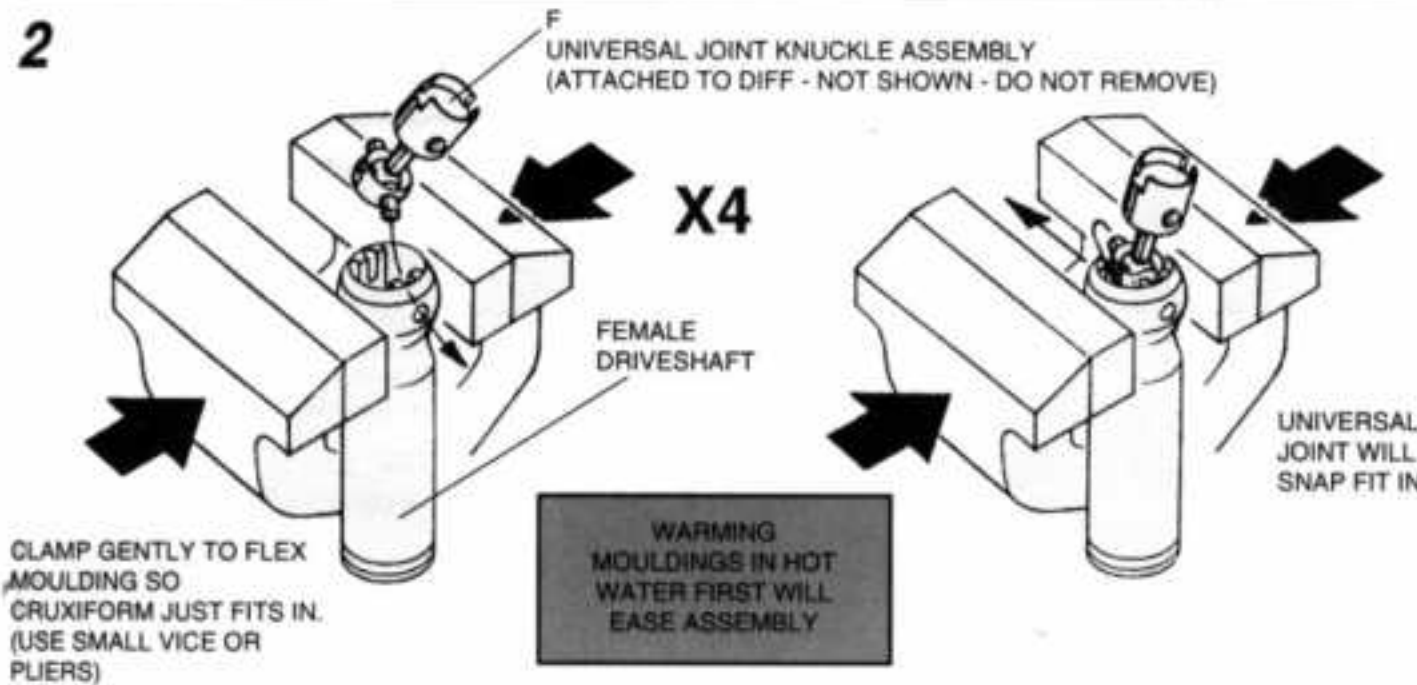

CLAMP GENTLY TO FLEX MOULDING SO CRUXIFORM JUST FITS IN. (USE SMALL VICE OR PLIERS)

WARMING MOULDINGS IN HOT WATER FIRST WILL EASE ASSEMBLY

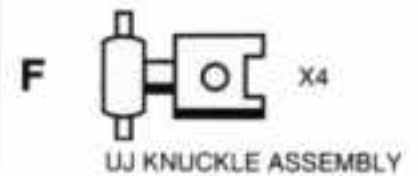
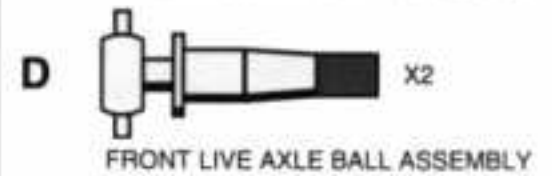
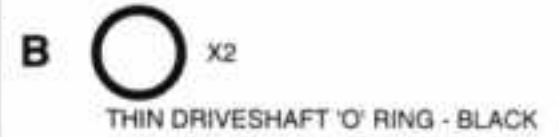

**3**

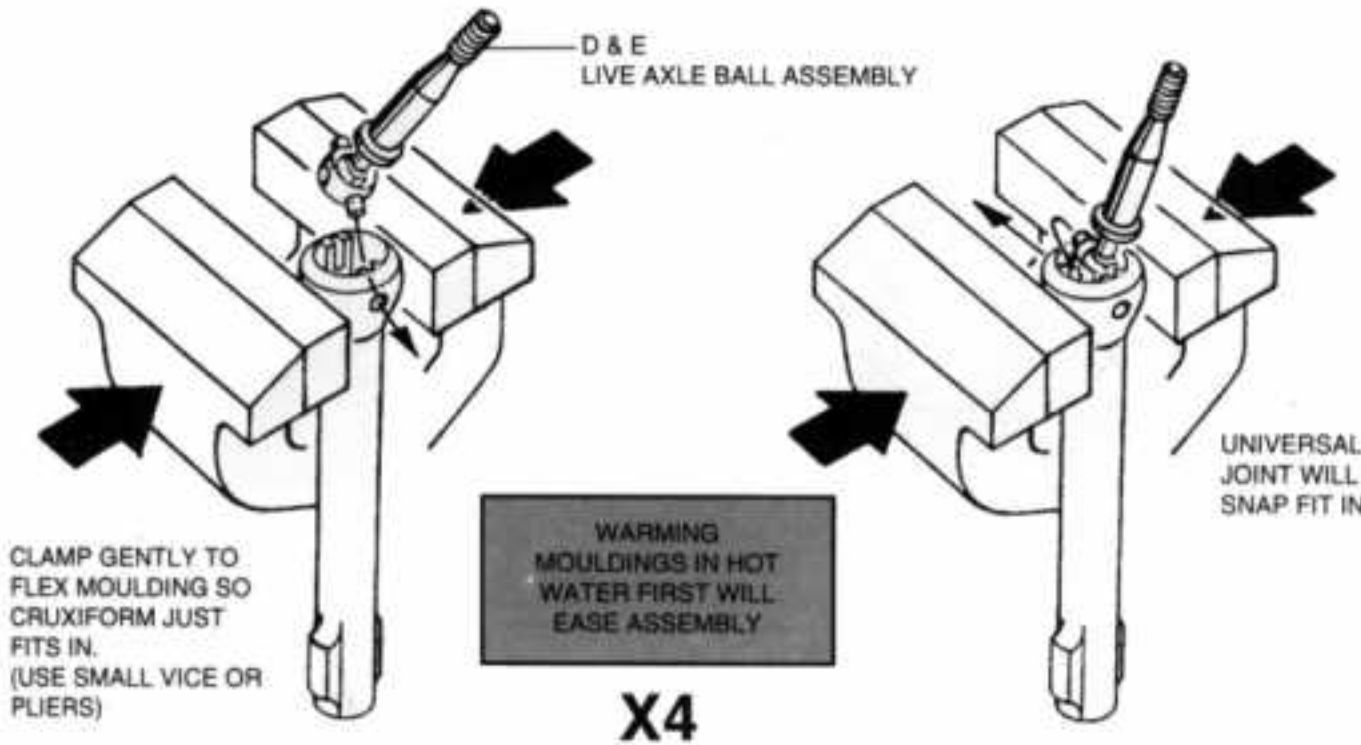

CLAMP GENTLY TO FLEX MOULDING SO CRUXIFORM JUST FITS IN. (USE SMALL VICE OR PLIERS)

WARMING MOULDINGS IN HOT WATER FIRST WILL EASE ASSEMBLY

**4**

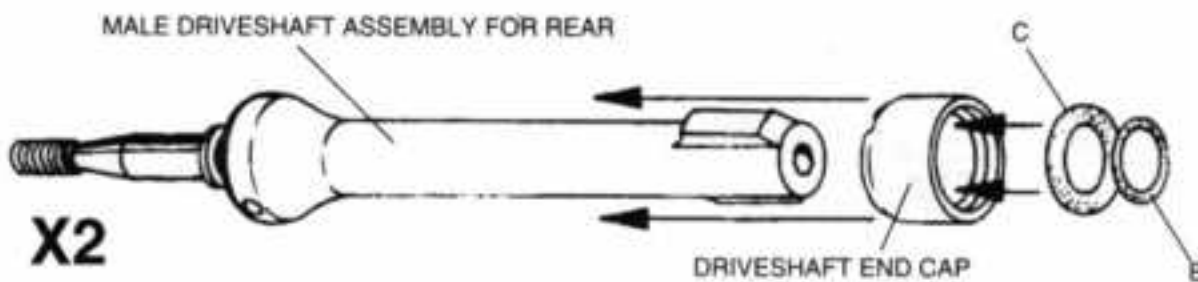

**X2**

**5**

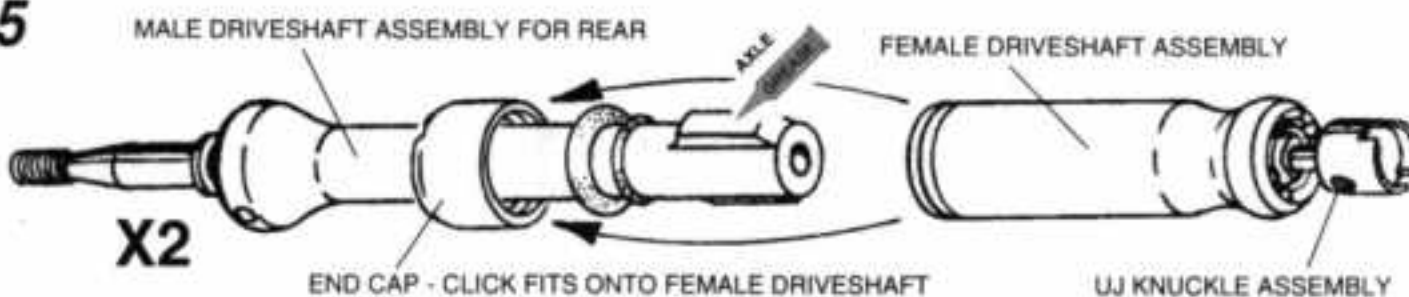

**X2**

**NOTE:**  
THE TWO FRONT DRIVESHAFTS HAVE TO BE ASSEMBLED LATER DURING CONSTRUCTION OF THE FRONT SUSPENSION

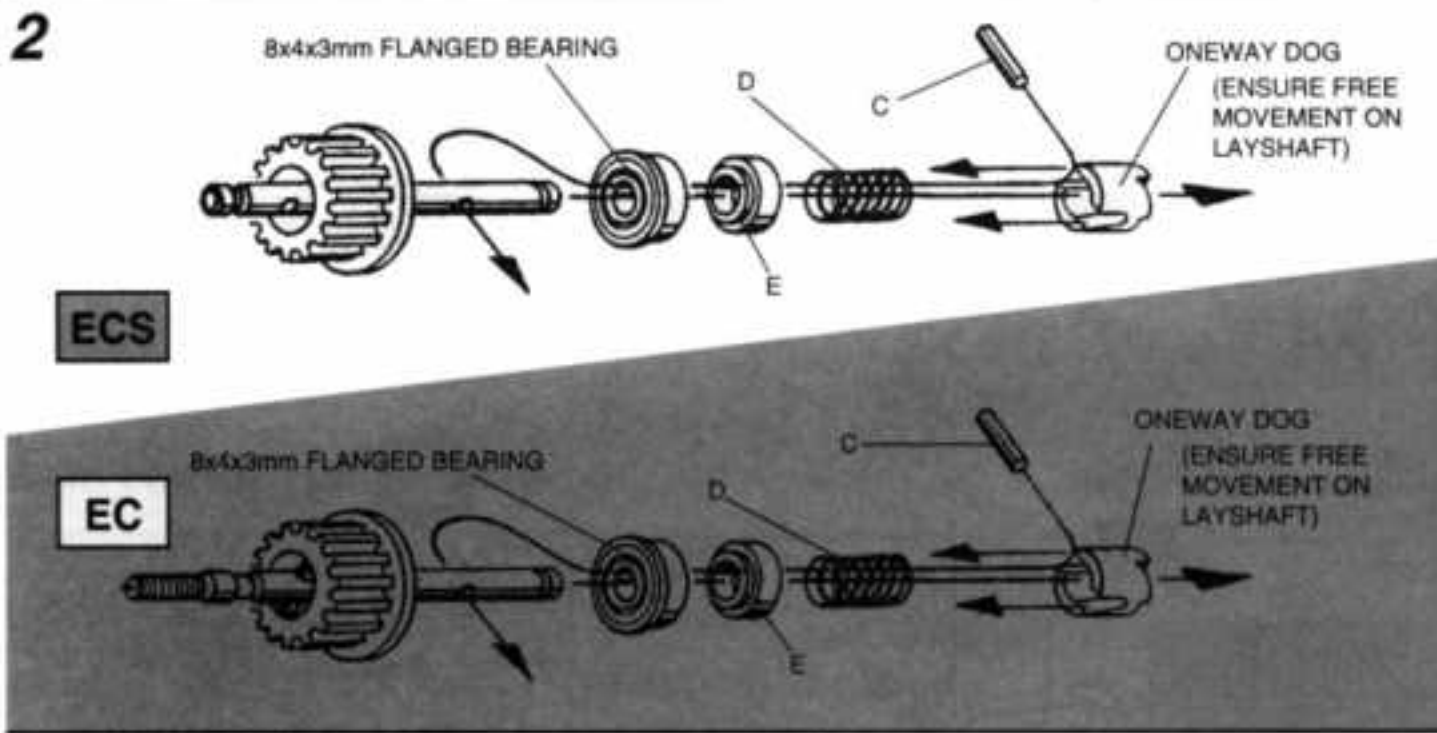
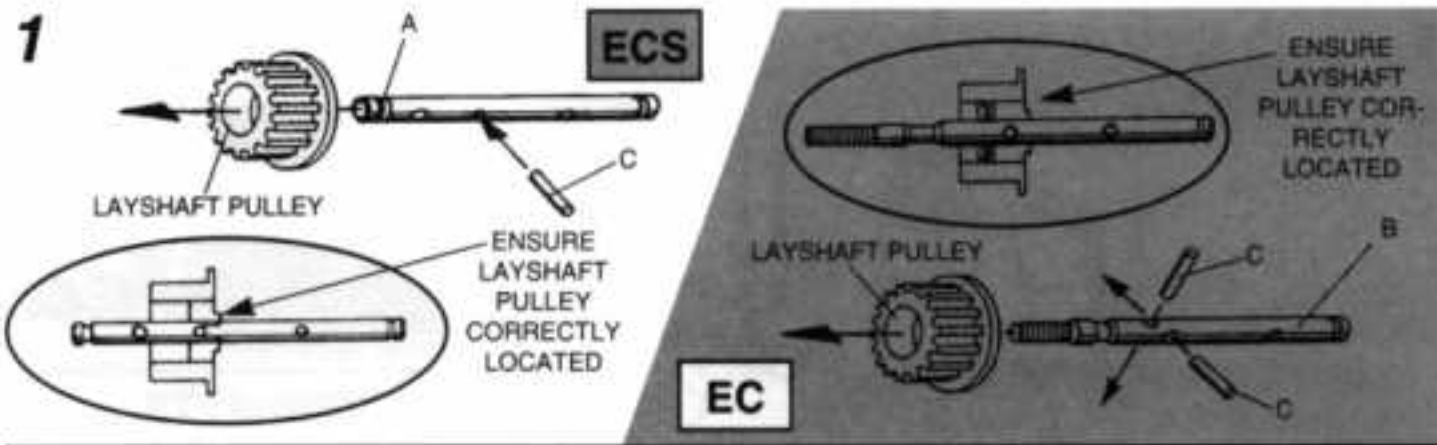

**A** NON SLIPPER LAYSHAFT 4WD X1

**B** SLIPPER LAYSHAFT 4WD X1

**C** X1  
8mm LONG x 1.5mm DIA PIN

**D** X1  
LAYSHAFT ONEWAY SPRING

**E** X1  
LAYSHAFT SPACER

**F** X1  
'E' CLIP

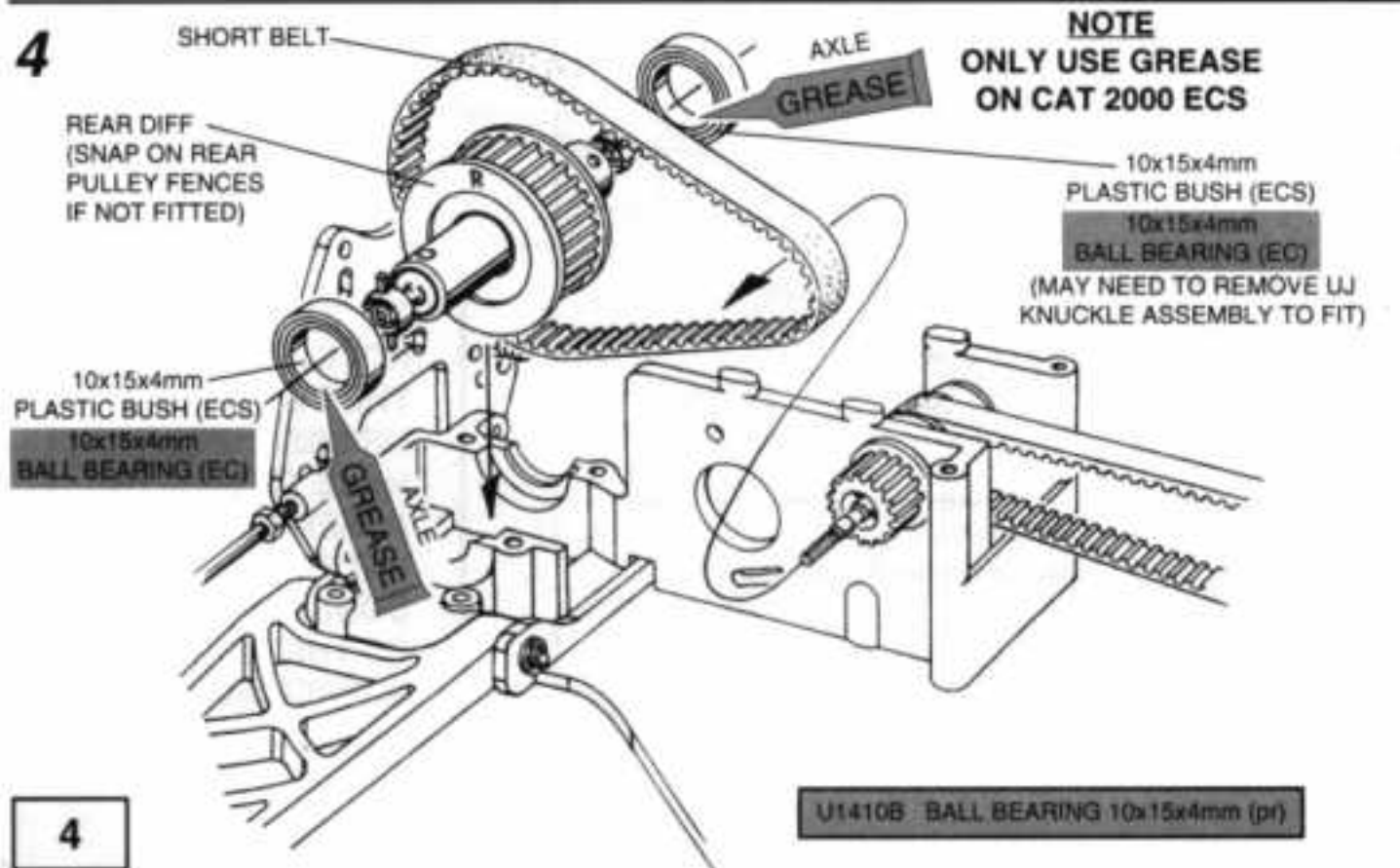
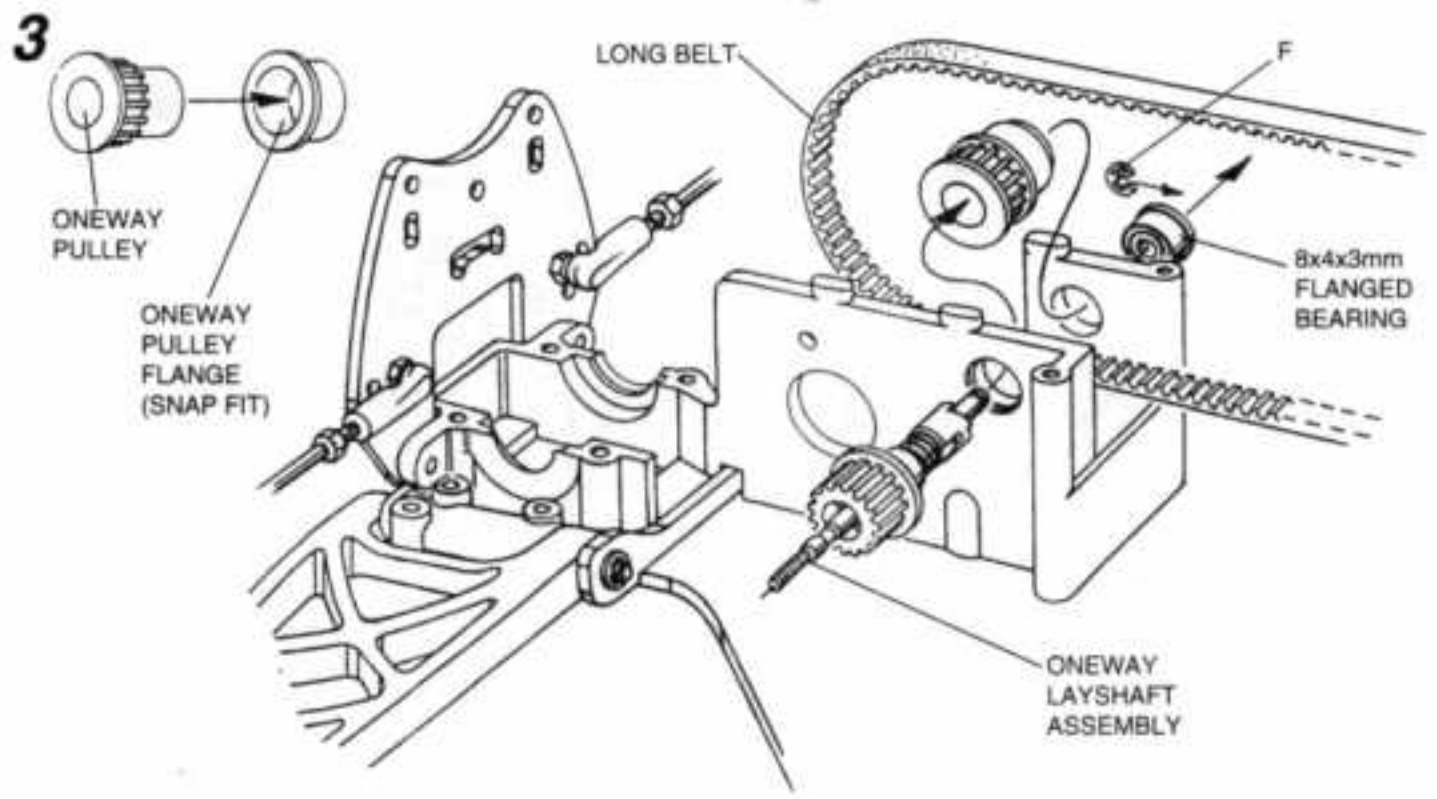

5

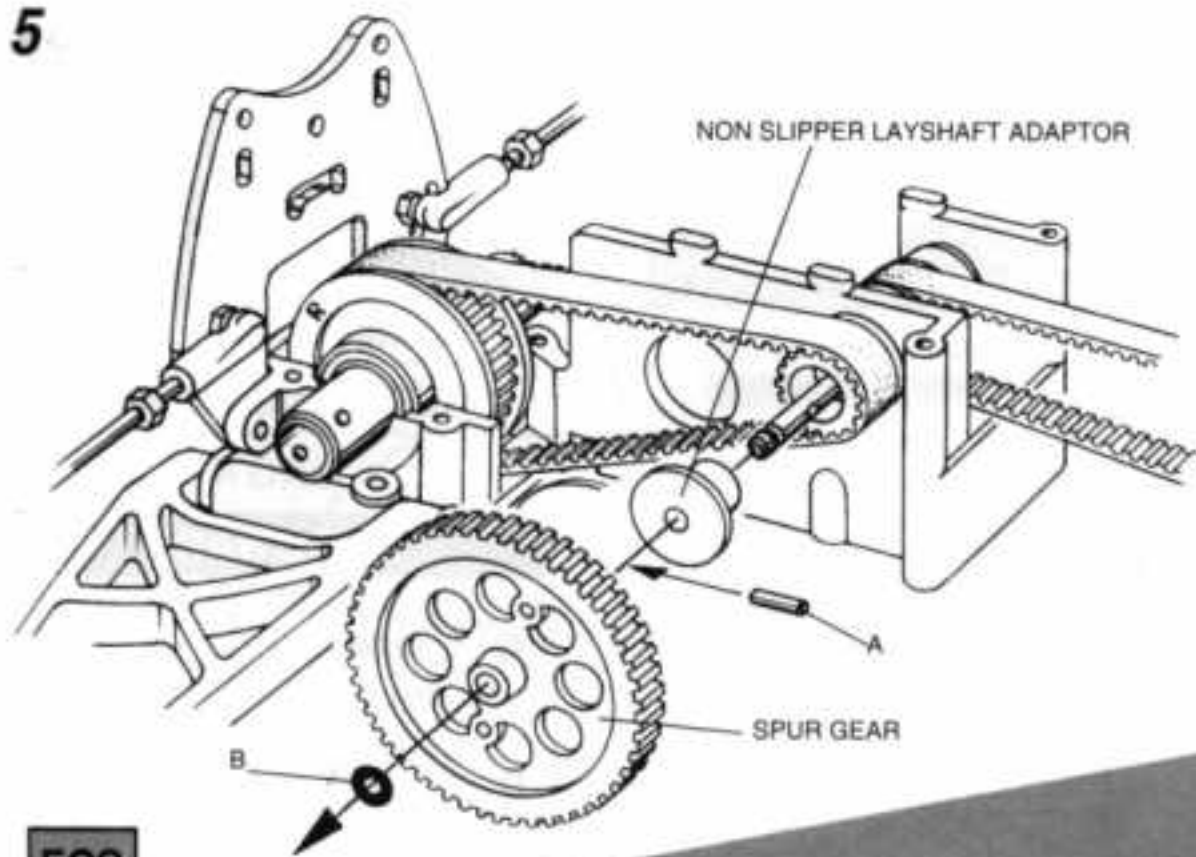

ECS

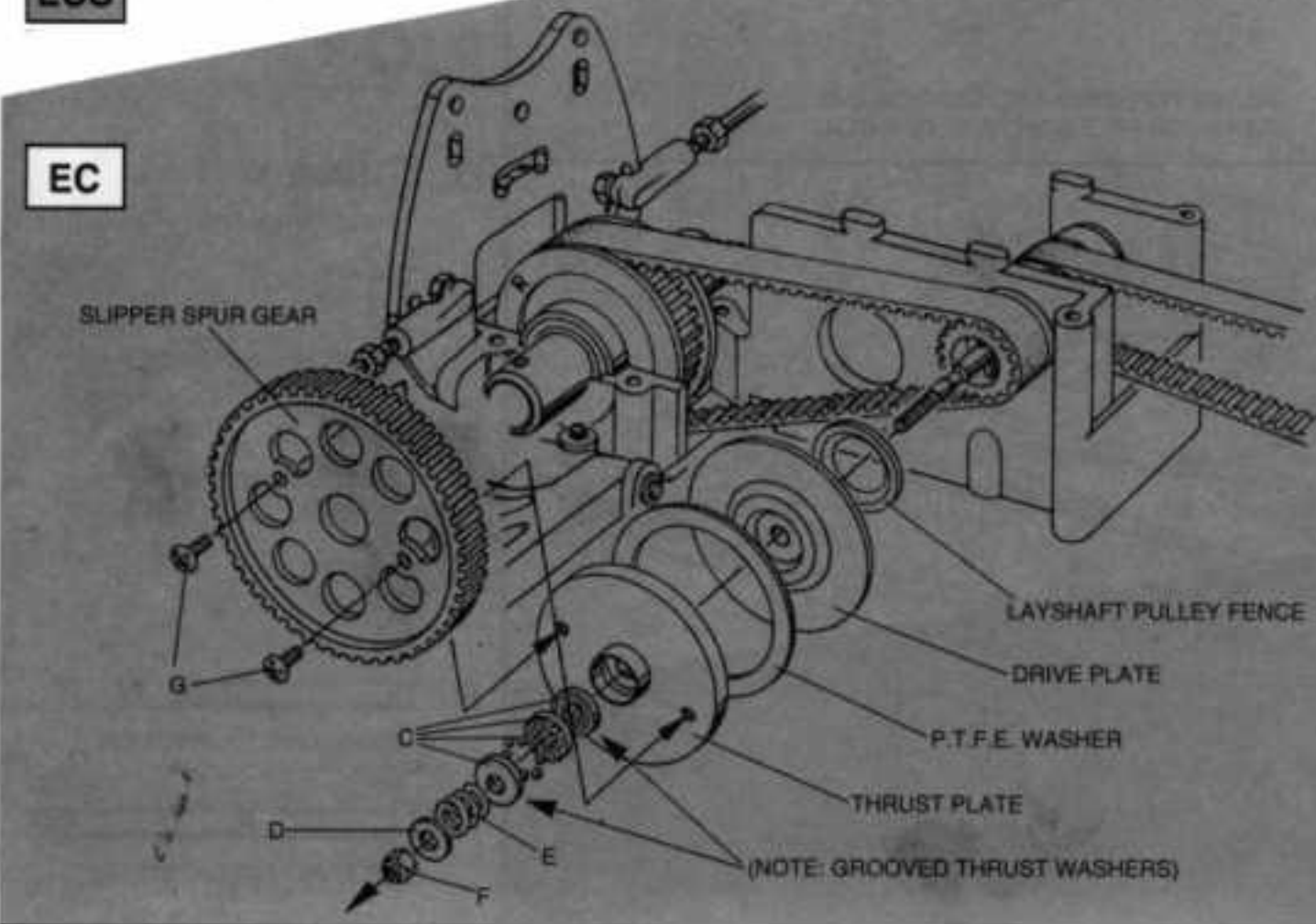

EC

6

FULLY TIGHTEN GRUB SCREW USING 1.5mm ALLEN KEY

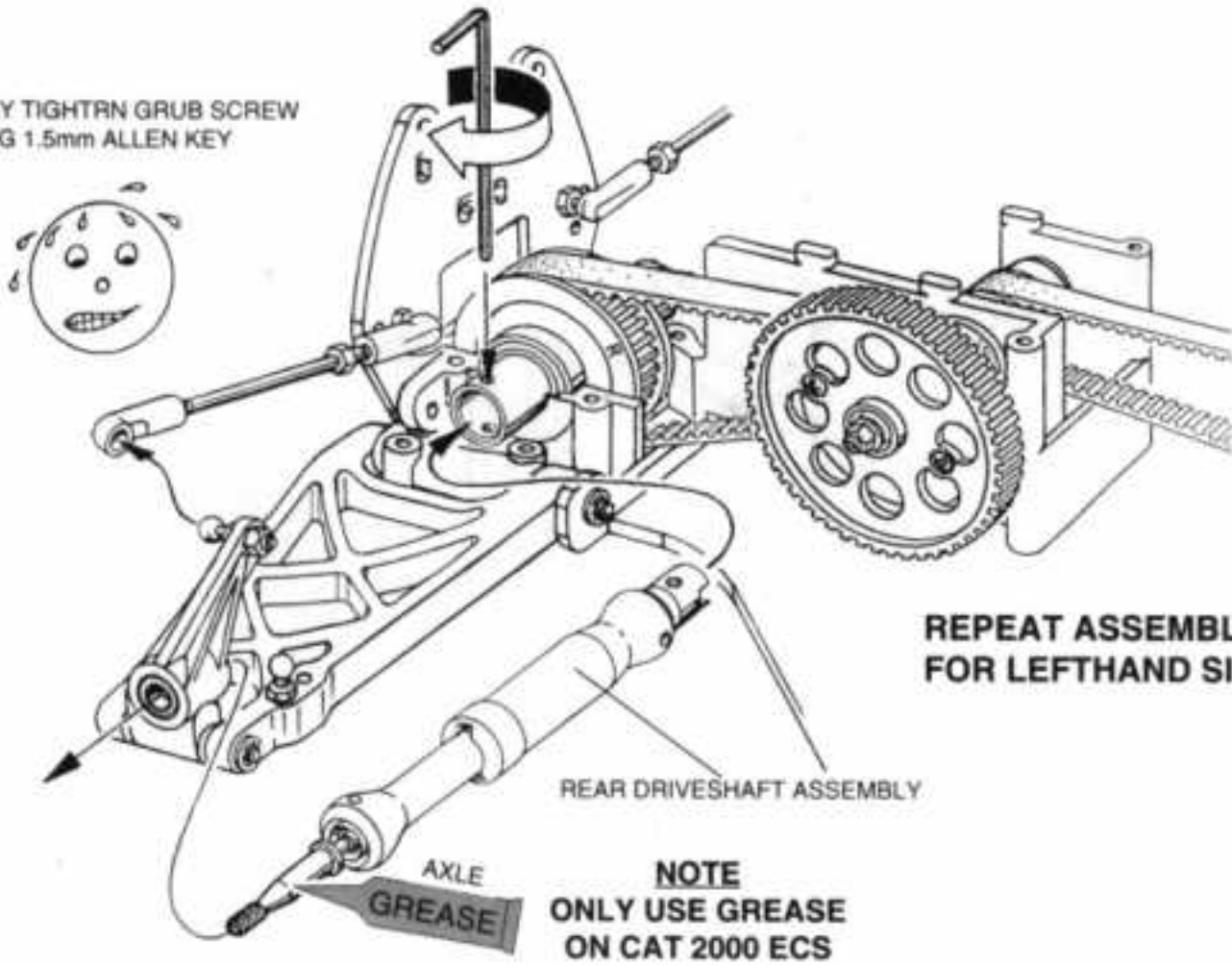

ECS

A  X1  
PIN 8mm LONG x 2.0mm DIA

B  X1  
'O' RING

EC

C  X2  
 X8  
 X1  
THRUST RACE ASSEMBLY

D  X1  
M3 STEEL WASHER

E  X1  
SLIPPER CLUTCH SPRING

F  X1  
M3 NYLOC NUT

G  X2  
M3 x 4mm PANHEAD SCREW

NOTE:  
THE TWO FRONT DRIVESHAFTS HAVE TO BE ASSEMBLED LATER DURING CONSTRUCTION OF THE FRONT SUSPENSION

1

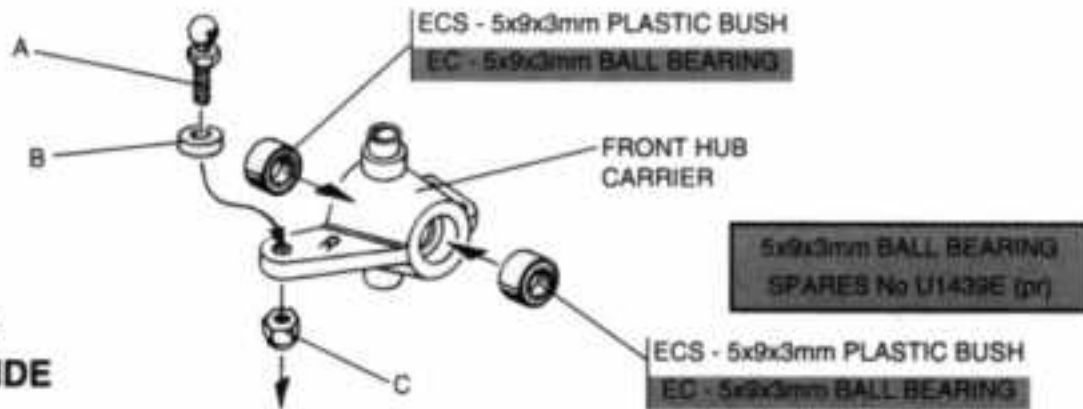

REPEAT FOR LEFTHAND SIDE

FRONT SUSPENSION

BAG 4

HARDWARE

2

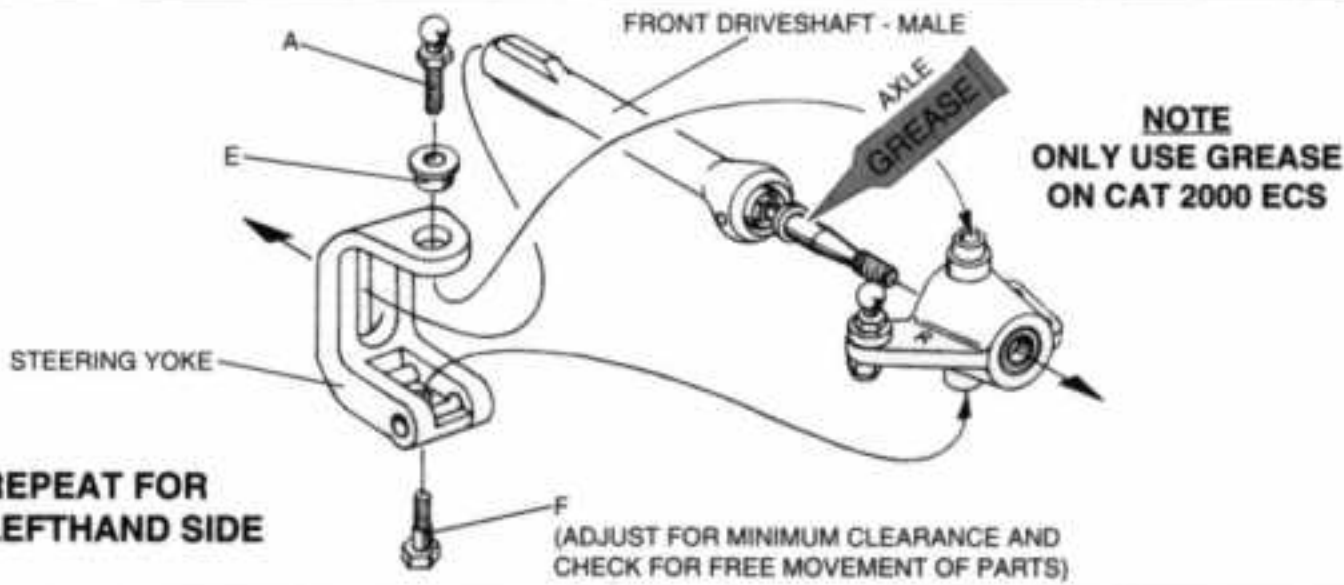

REPEAT FOR LEFTHAND SIDE

3

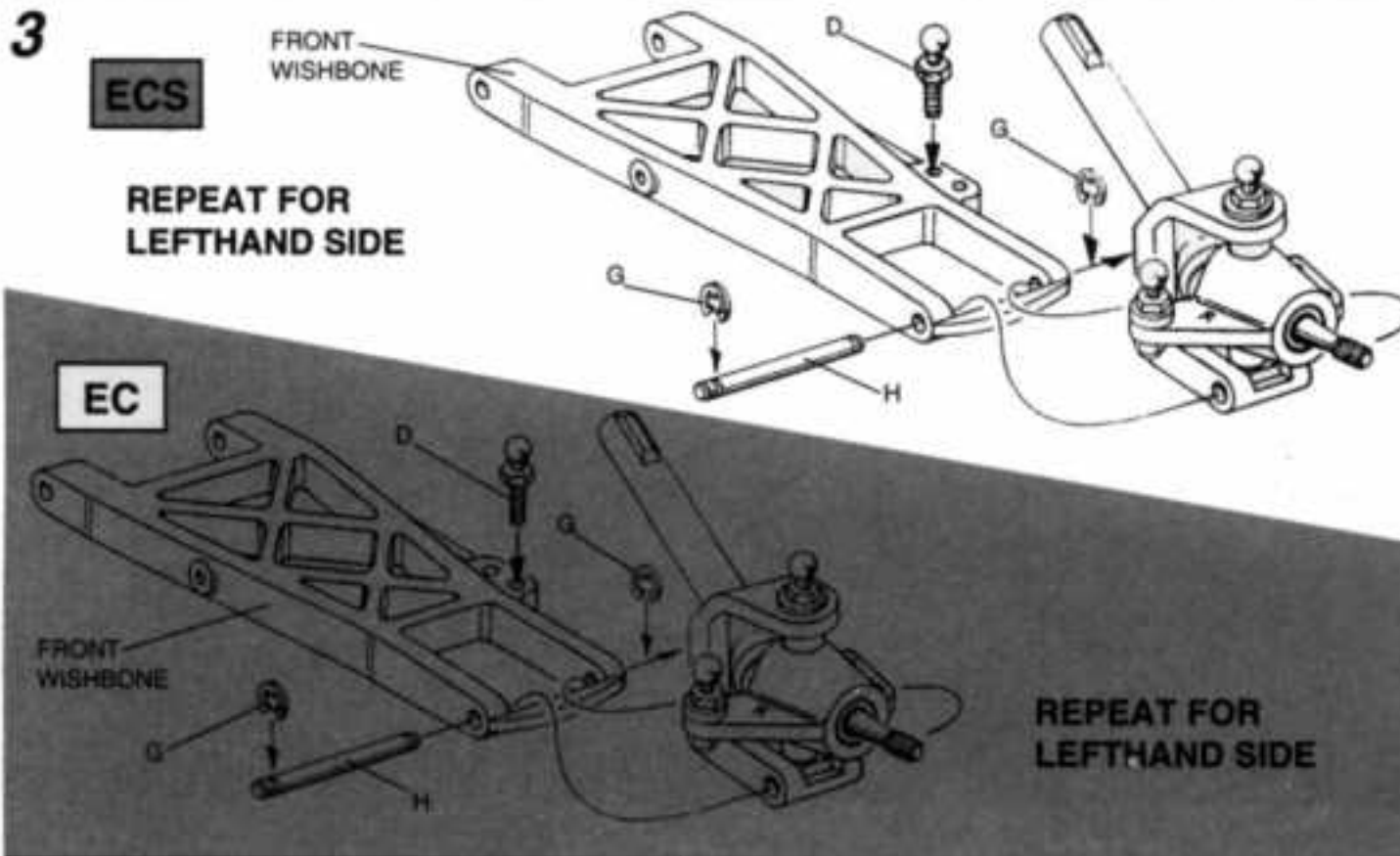

REPEAT FOR LEFTHAND SIDE

REPEAT FOR LEFTHAND SIDE



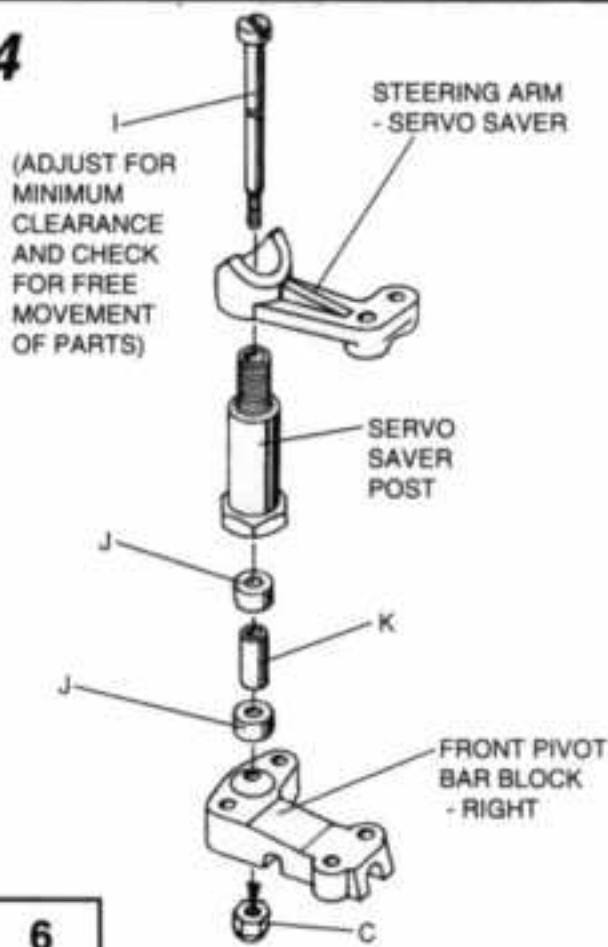





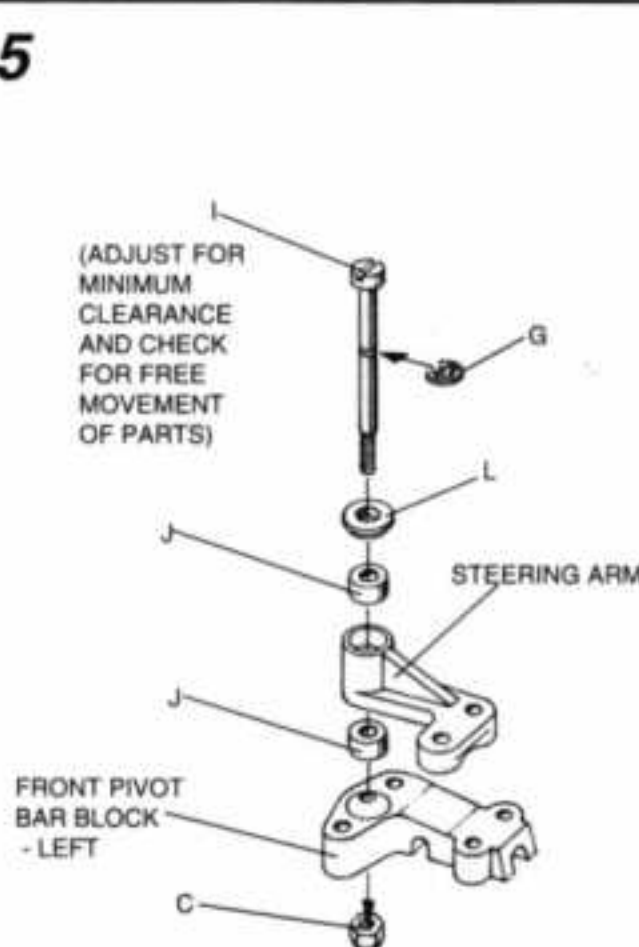



4

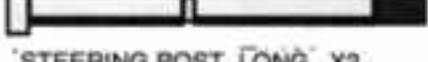

6

5



- A  X4  
BALL STUD LONG
- B  X2  
1.6mm THICK NYLON WASHER
- C  X4  
M3 NYLOC NUT
- D  X2  
BALL STUD SHORT
- E  X2  
STEPPED YOKE WASHER
- F  X2  
SHOULDER SCREW
- G  X5  
'E' CLIP
- H  X2  
28mm LONG 1/8" PIVOT PIN
- I  X2  
'STEERING POST LONG' X2
- J  X4  
STEERING LEVER BUSH
- K  X1  
SPACER TUBE
- L  X1  
STEPPED WASHER



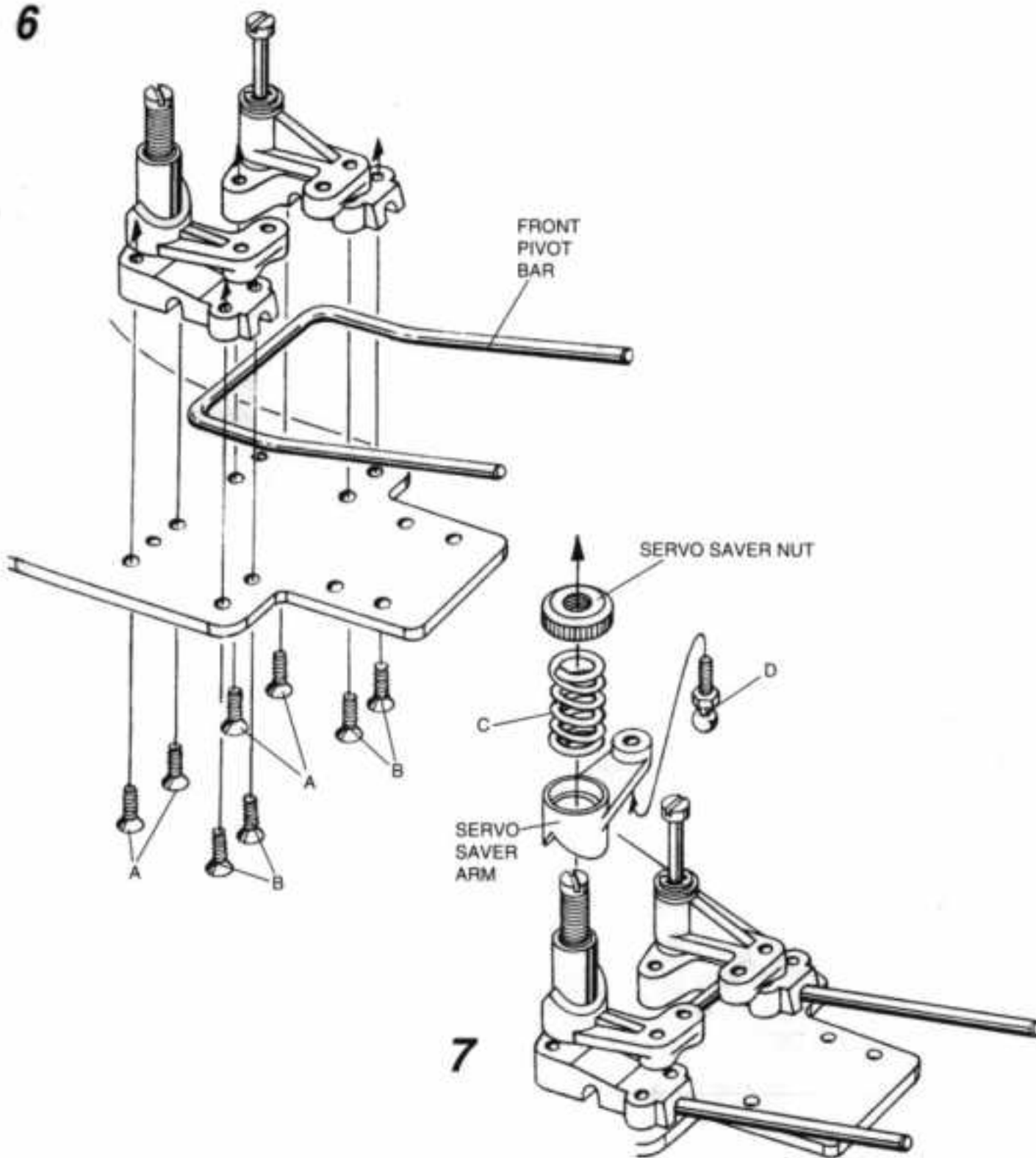

6



**FRONT SUSPENSION**

**BAG 4 & 5**

**HARDWARE**

- A**  X8  
No4 x 3/8" SELFTAP PANHEAD SCREW
- B**  X4  
M3 x 8mm CSK SCREW
- C**  X1  
SERVO SAVER SPRING
- D**  X1  
BALL STUD SHORT

8

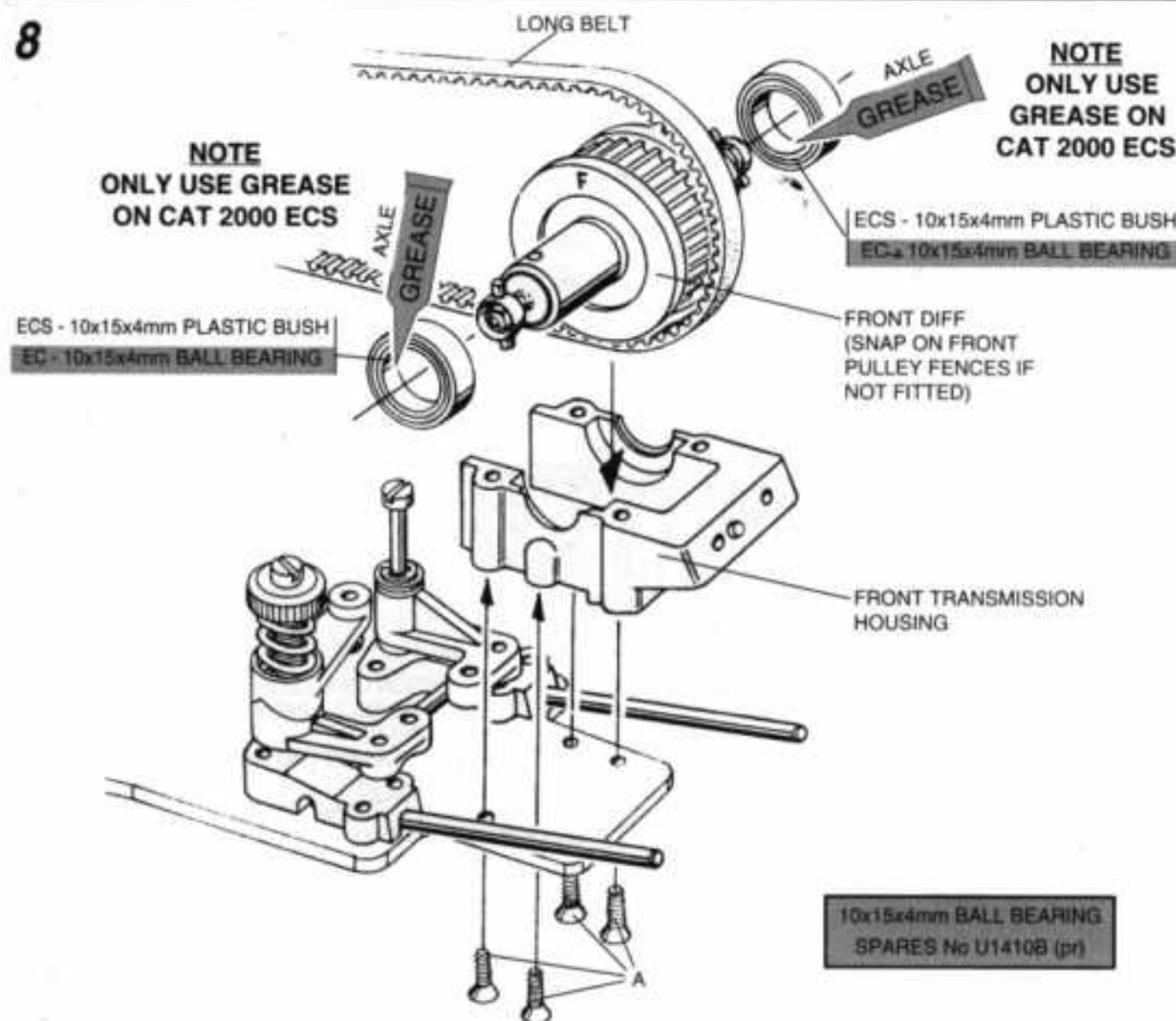

9

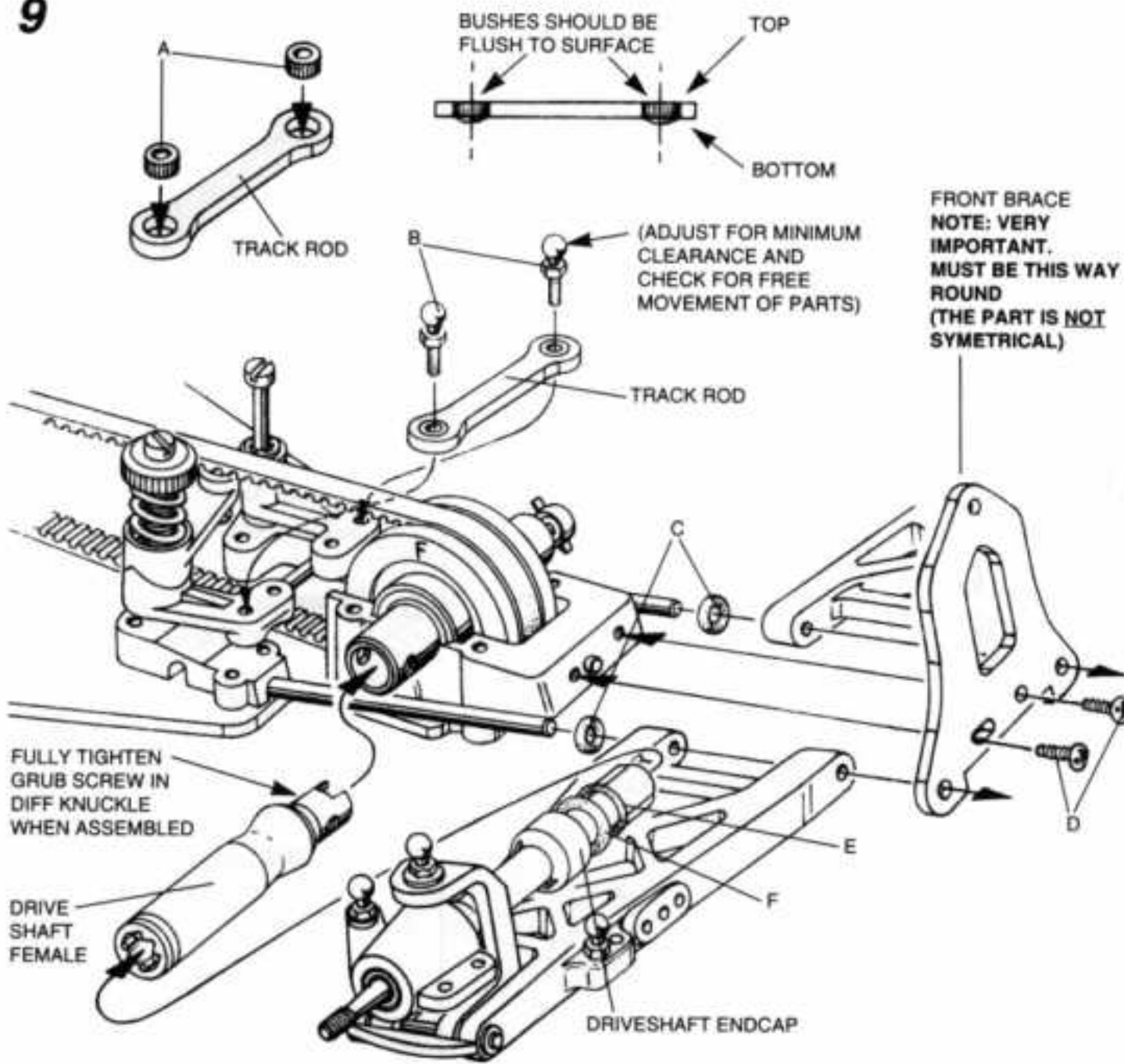

REPEAT DRIVESHAFT ASSEMBLY FOR LEFTHAND SIDE

10

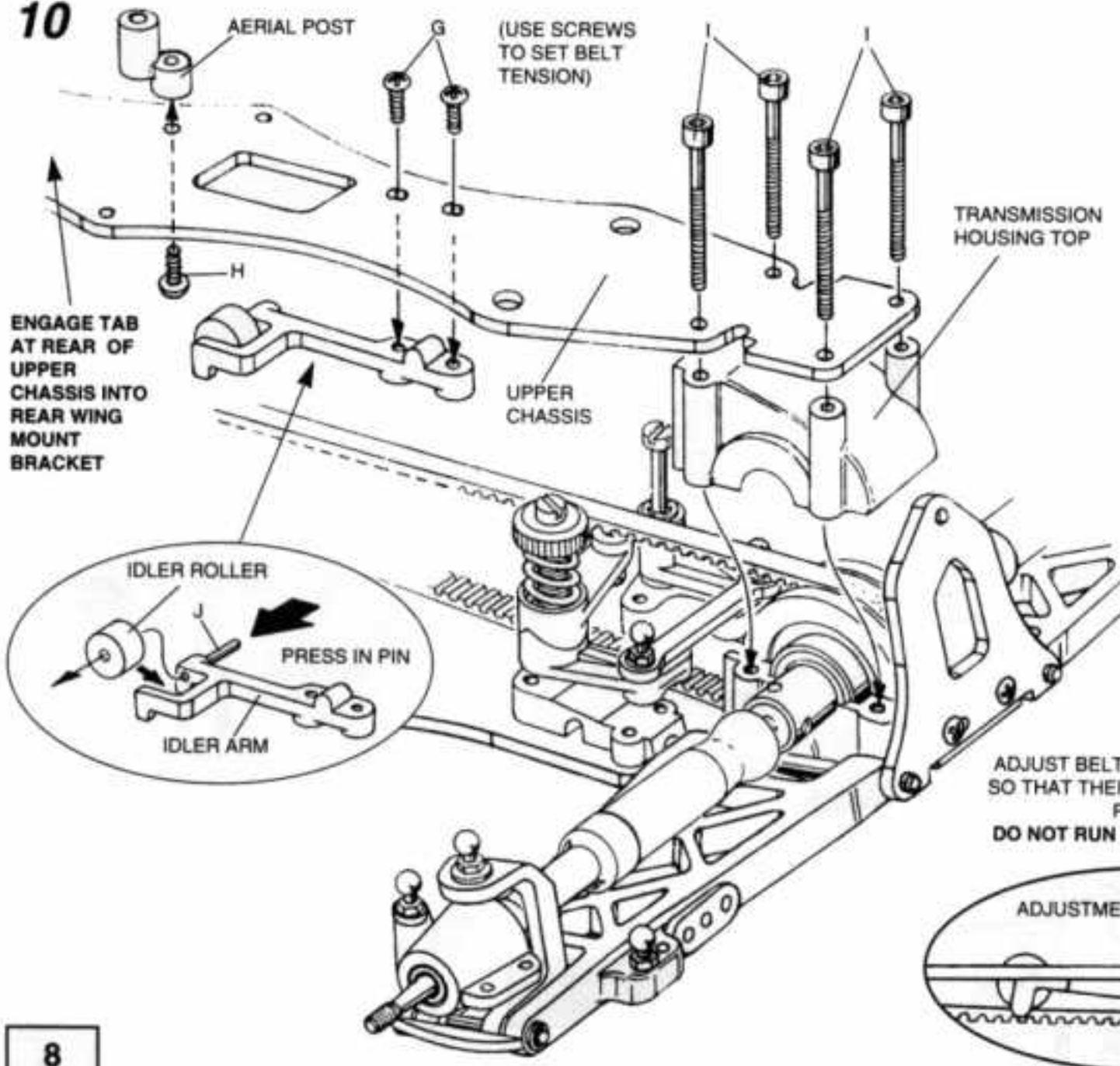

FRONT SUSPENSION

BAG 5

HARDWARE

- A ○ X2  
CENTRE TRACKROD BUSH
- B ○ X2  
BALL STUD LONG
- C ○ X2  
SMALL FAT 'O'RING - RED
- D ⚙ X2  
No4 x 1/4" SELFTAP PANHEAD SCREW
- E ○ X2  
THIN DRIVESHAFT 'O'RING - BLACK
- F ○ X2  
FAT DRIVESHAFT 'O'RING - BLACK
- G ⚙ X2  
No4 x 1/2" SELFTAP PANHEAD SCREW
- H ⚙ X1  
No4 x 3/8" SELFTAP PANHEAD SCREW
- I ⚙ X4  
M3 x 30mm CAPHEAD SCREW
- J — X1  
13mm LONG x 1.5mm DIA PIN

11



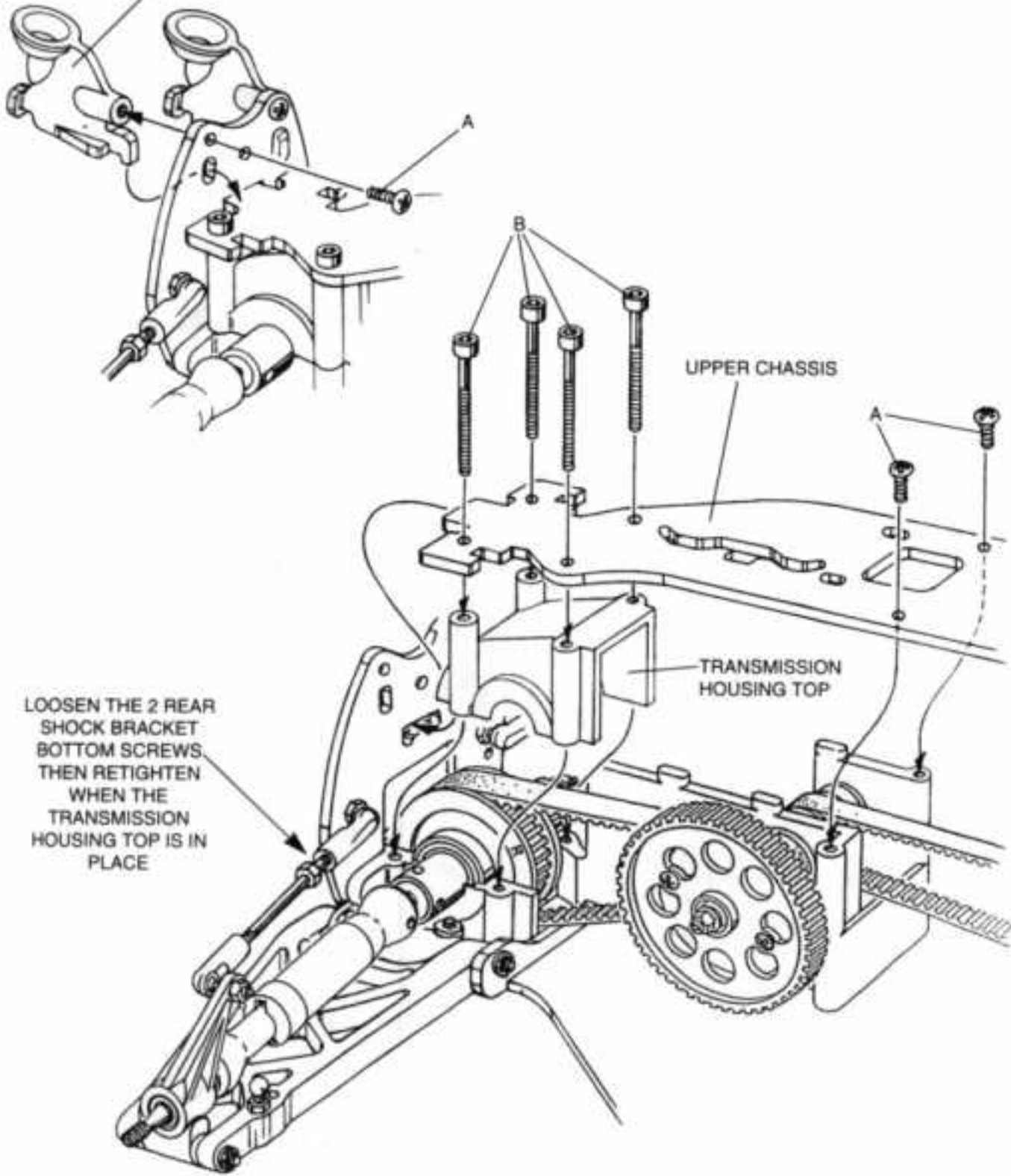

WING MOUNT BRACKET



**FRONT SUSPENSION**

**BAG 5**

**HARDWARE**

- A**  X4  
No4 x 3/8" SELFTAP PANHEAD SCREW
- B**  X4  
M3 x 30mm CAPHEAD SCREW
- C**  X2  
BALL STUD SHORT
- D**  X3  
M3 NYLOC NUT
- E**  X1  
M3 x 20mm PANHEAD SCREW

12

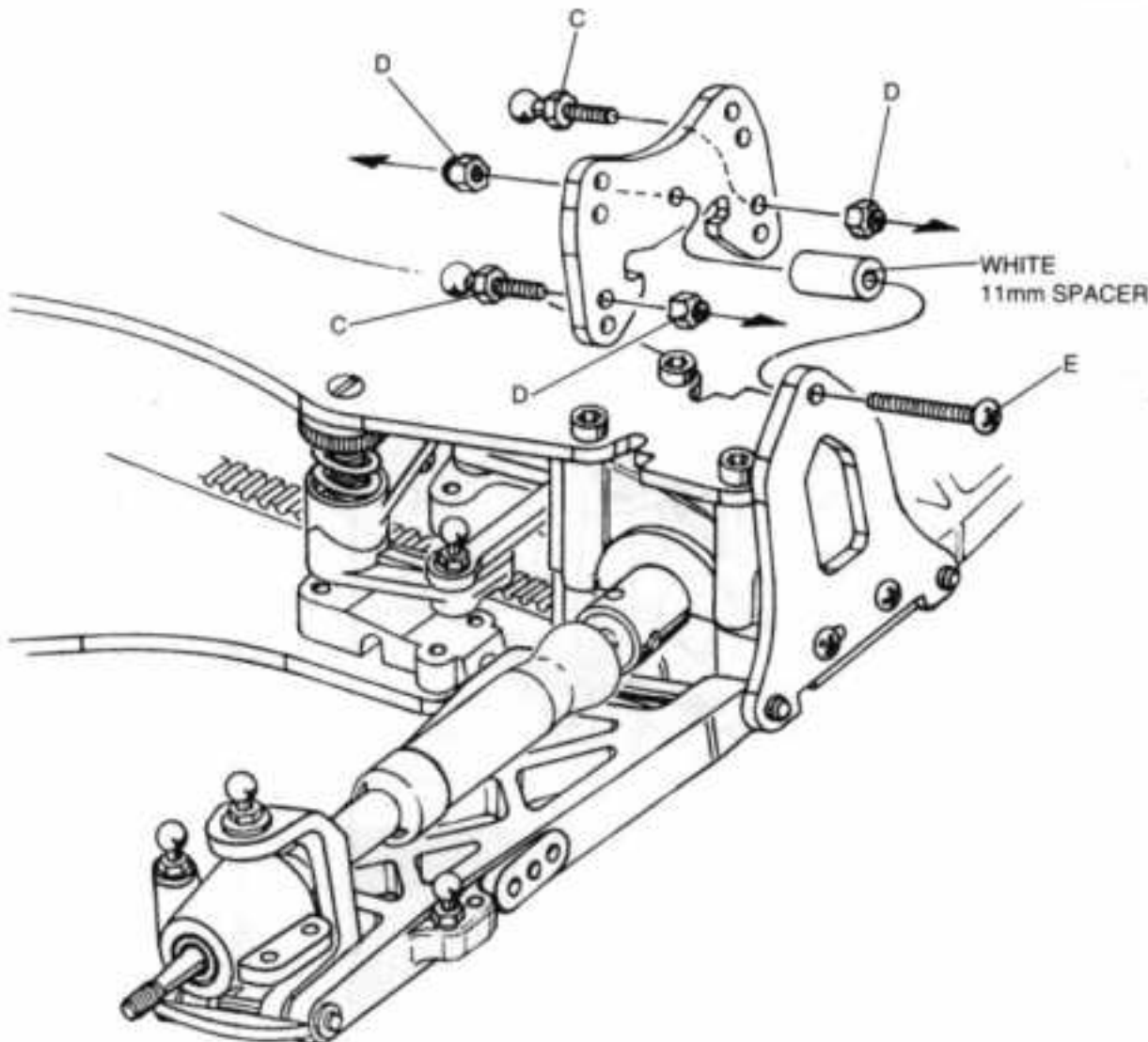

**FRONT SUSPENSION**

**BAG 5**

**HARDWARE**

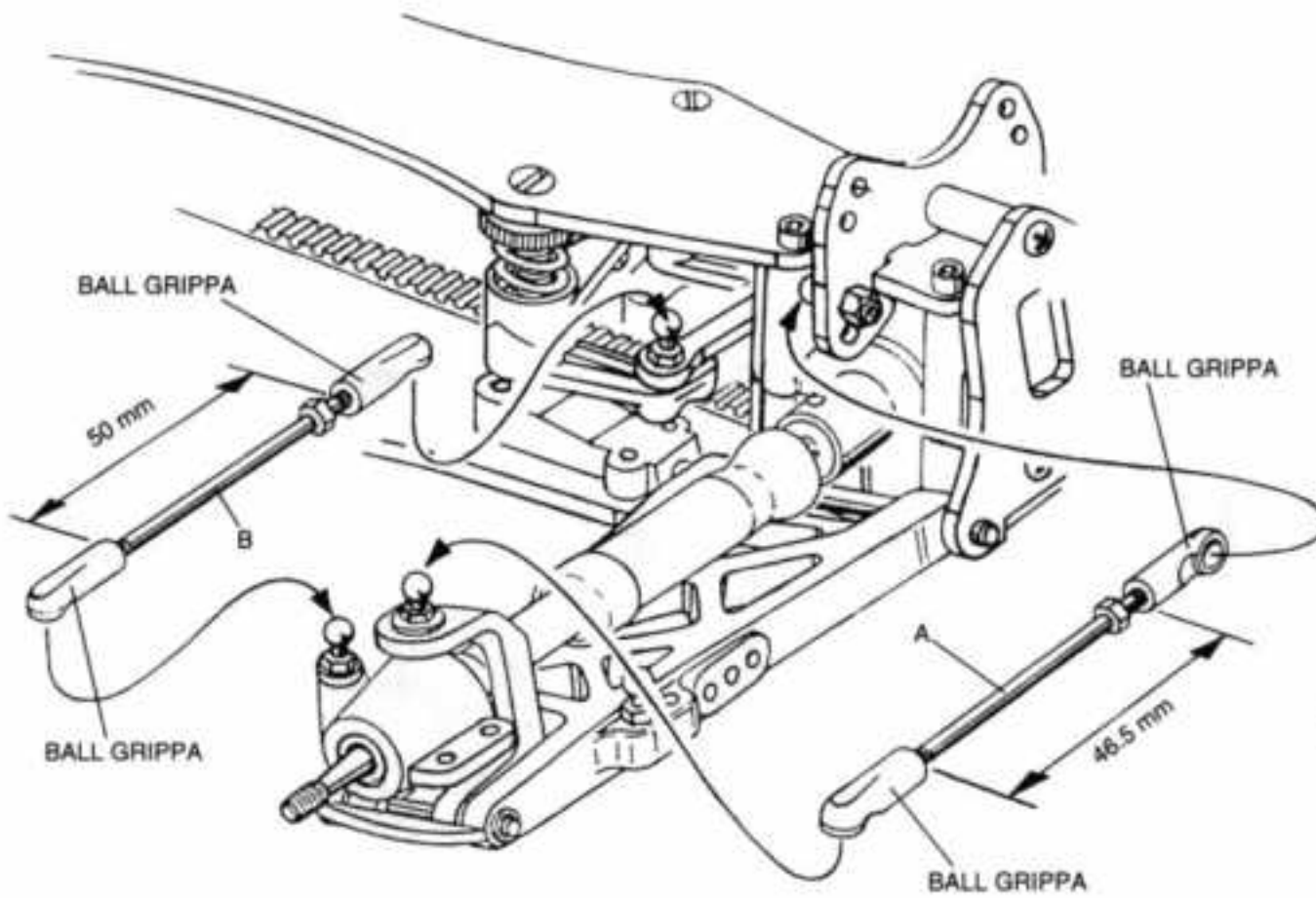

REPEAT FOR LEFTHAND SIDE

**A** 60mm TURNBUCKLE X2



**B** 65mm TURNBUCKLE X2



**C**  X2  
No4 x 1/2" SELFTAP PANHEAD SCREW

**D**  X2  
No4 x 1/2" SELFTAP CSK SCREW

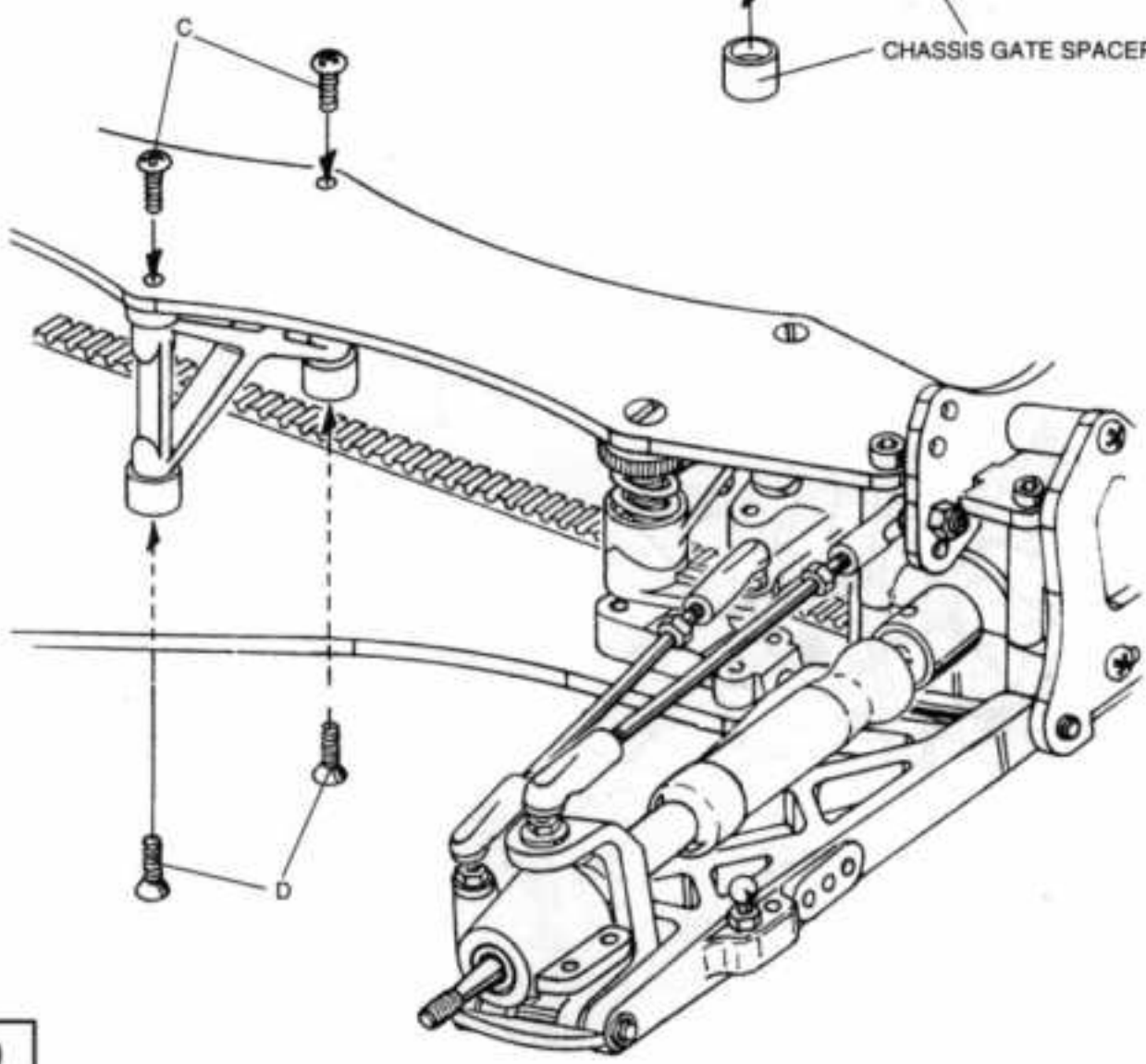
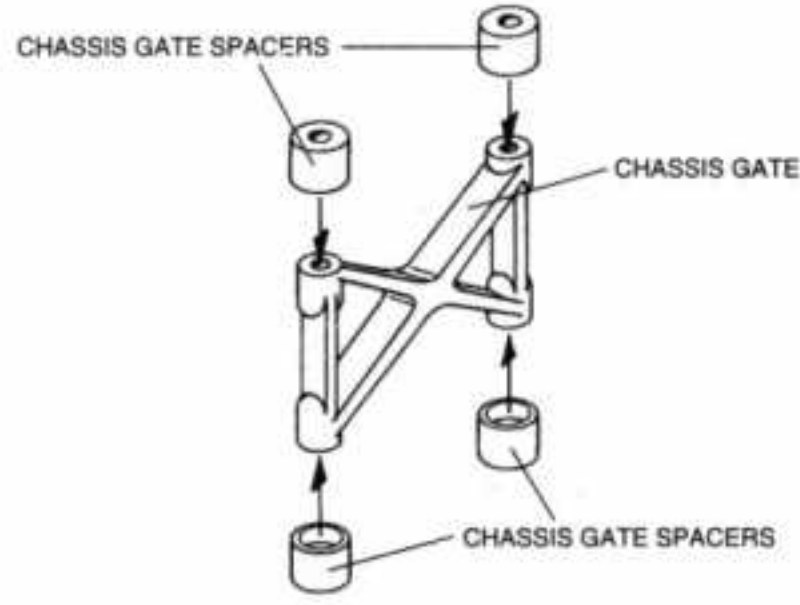

1

REAR X2

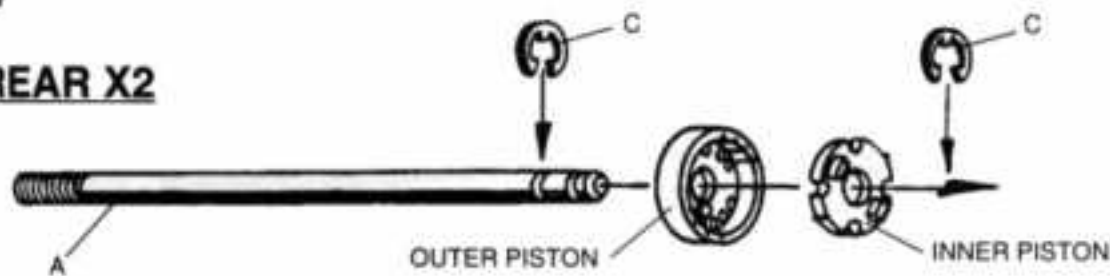

FRONT X2

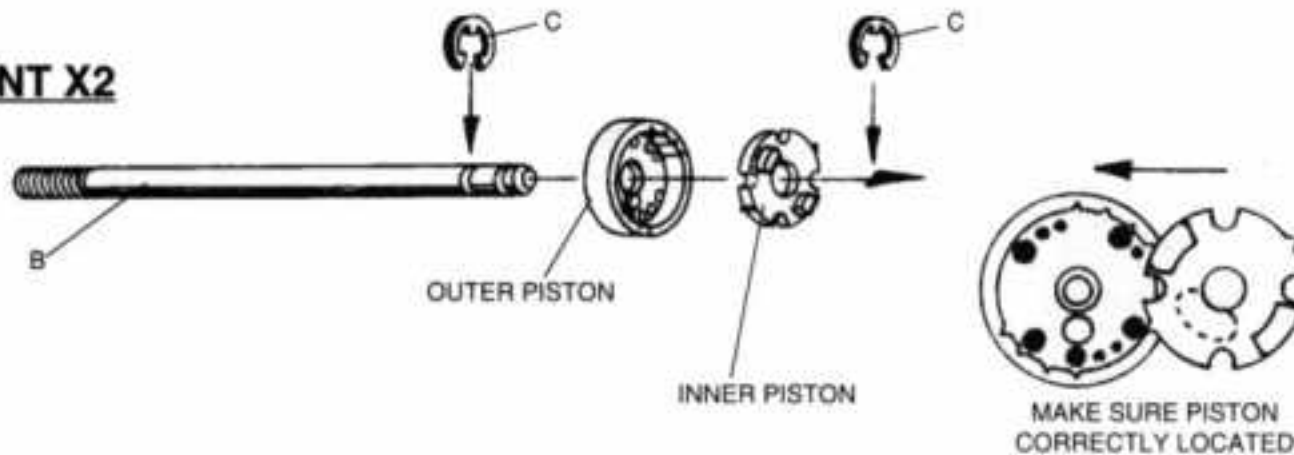

SHOCK ABSORBERS

**HARDWARE**

- A** LONG SHOCK ROD X2
- B** MEDIUM SHOCK ROD X2
- C** X4 'E' CLIP
- D** X4 SMALL FAT 'O' RING
- E** X4 LARGE FAT 'O' RING
- F** X4 LARGE THIN 'O' RING
- G** X4 FOAM VOLUME COMPENSATOR

2

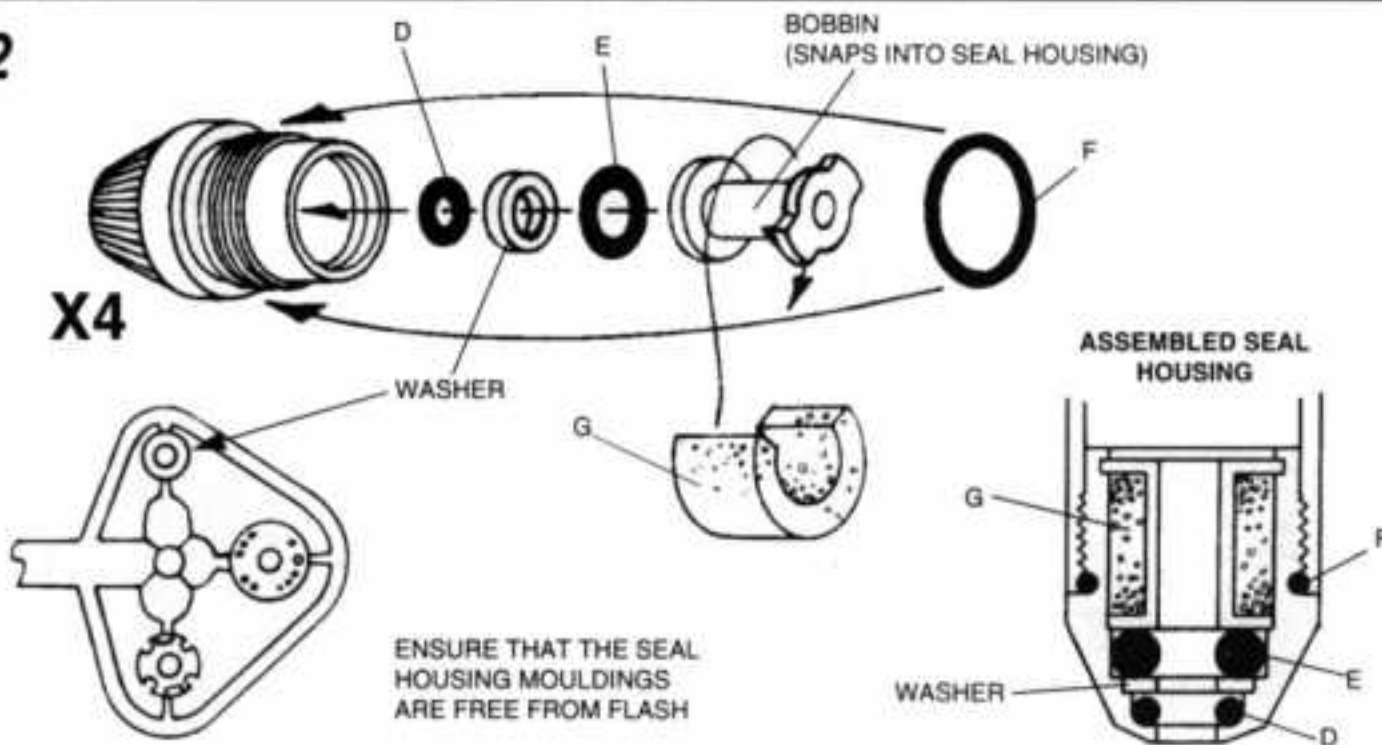

3

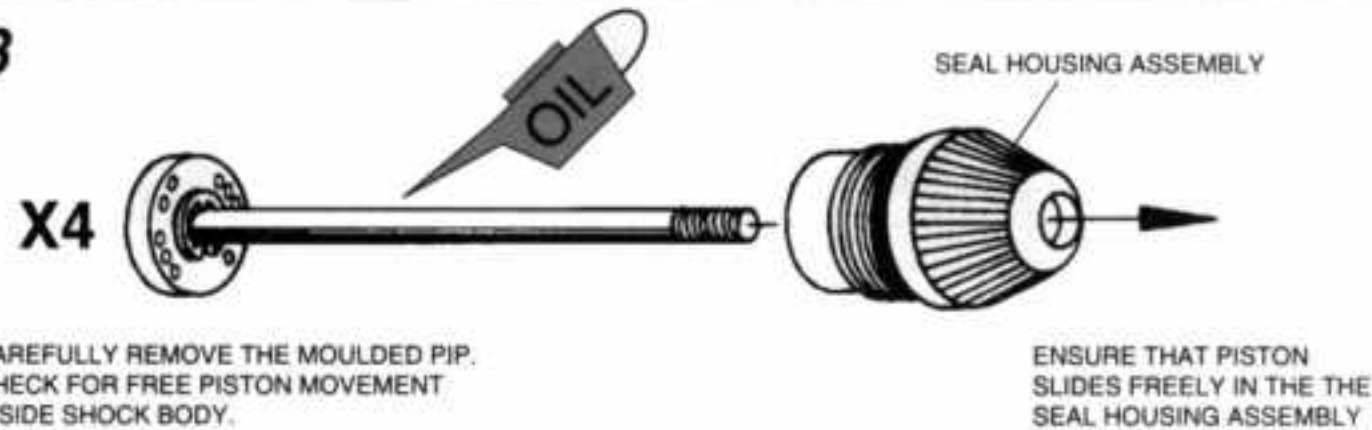

4

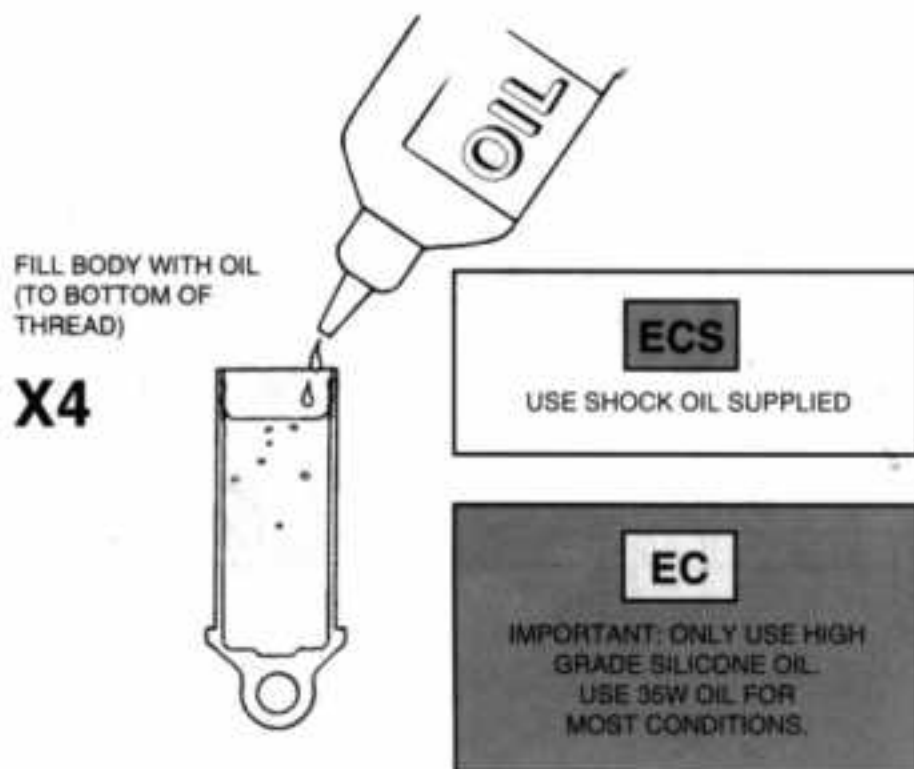

**SCHUMACHER SEL. A RANGE OF HIGH QUALITY SILICONE SHOCK OIL**

- G010U SCHUMACHER SILICONE SHOCK OIL - 10W
- G015A SCHUMACHER SILICONE SHOCK OIL - 15W
- G020F SCHUMACHER SILICONE SHOCK OIL - 20W
- G025L SCHUMACHER SILICONE SHOCK OIL - 25W
- G030T SCHUMACHER SILICONE SHOCK OIL - 30W
- G035Y SCHUMACHER SILICONE SHOCK OIL - 35W
- G040E SCHUMACHER SILICONE SHOCK OIL - 40W
- G045K SCHUMACHER SILICONE SHOCK OIL - 45W
- G050R SCHUMACHER SILICONE SHOCK OIL - 50W
- G055X SCHUMACHER SILICONE SHOCK OIL - 55W
- G060D SCHUMACHER SILICONE SHOCK OIL - 60W
- G070P SCHUMACHER SILICONE SHOCK OIL - 70W
- G080C SCHUMACHER SILICONE SHOCK OIL - 80W

5

DAMPING ADJUSTMENT

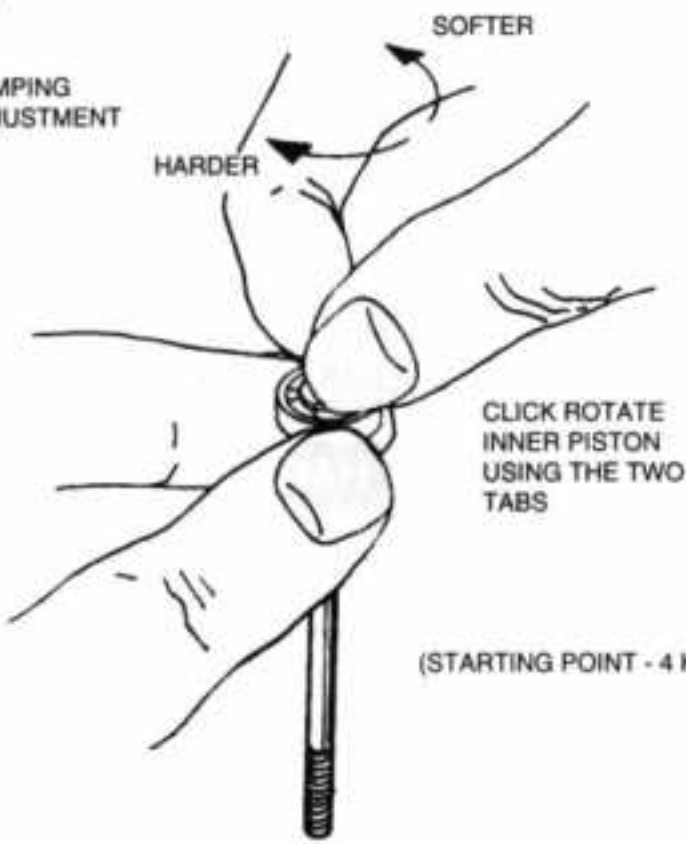

SOFT

HARD



**Schumacher**

**NEW 2000 E.C.**  
THE ONLY ORIGINAL

**SHOCK ABSORBERS**

**HARDWARE**

6

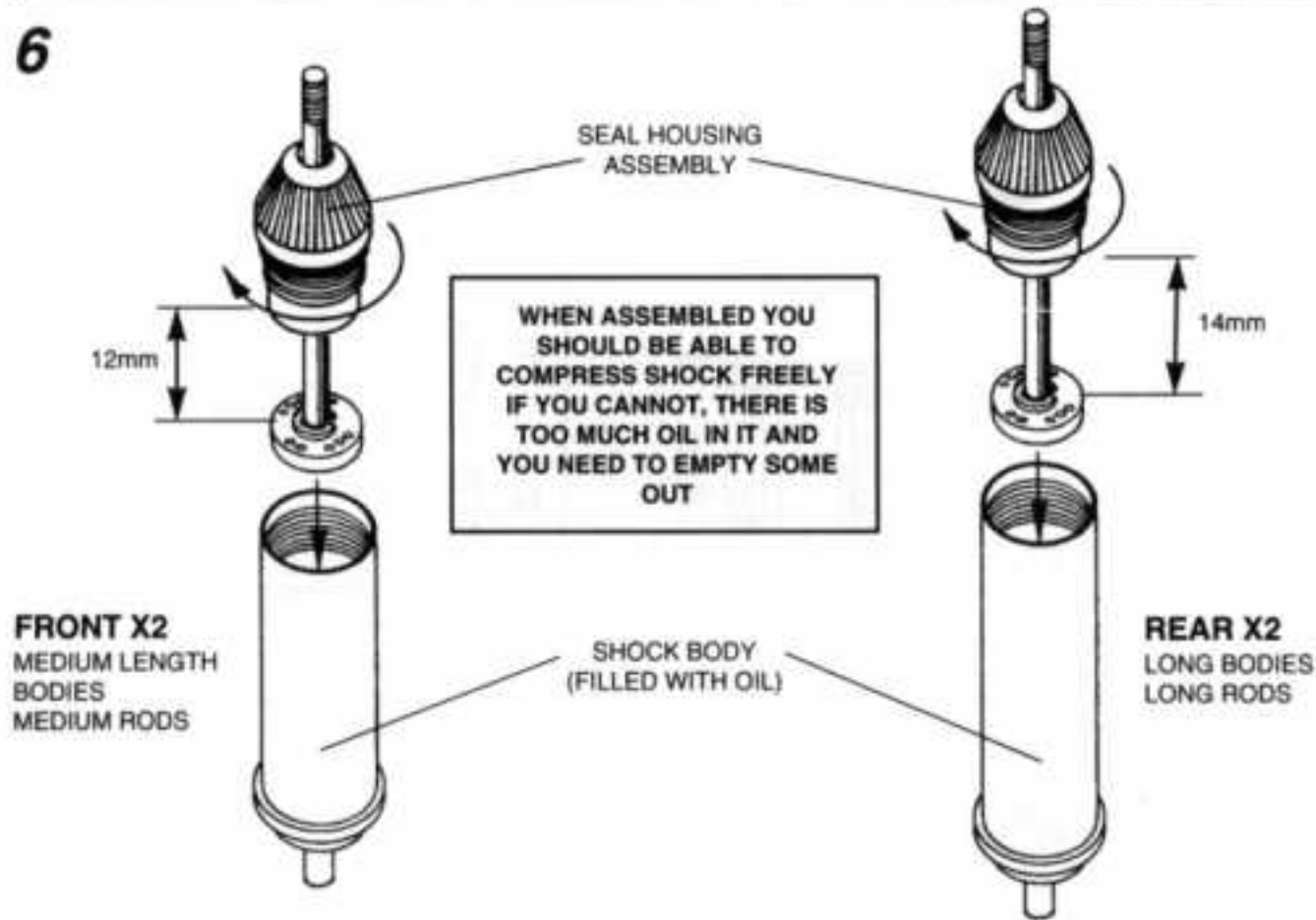

7

NOTE: SEAL HOUSING FULLY SCREWED IN - NO 'O' RING VISIBLE

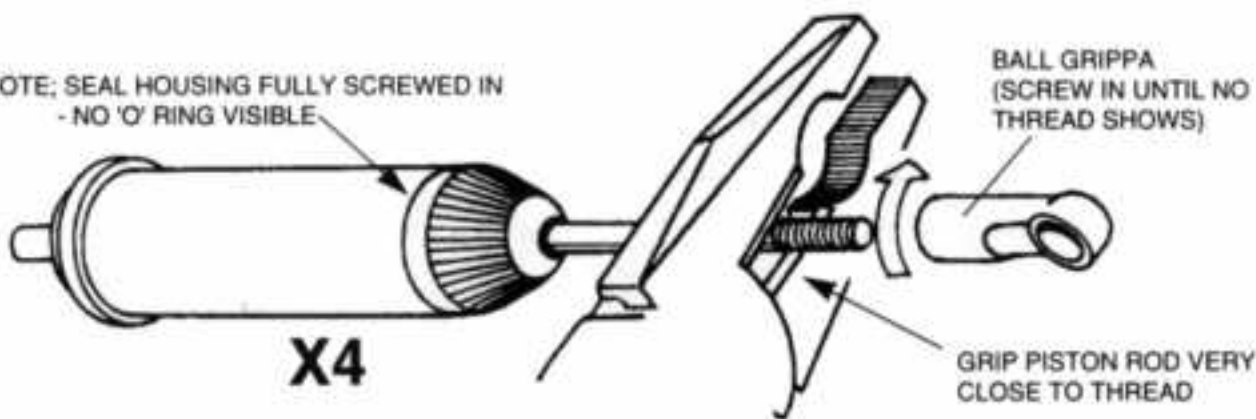

8

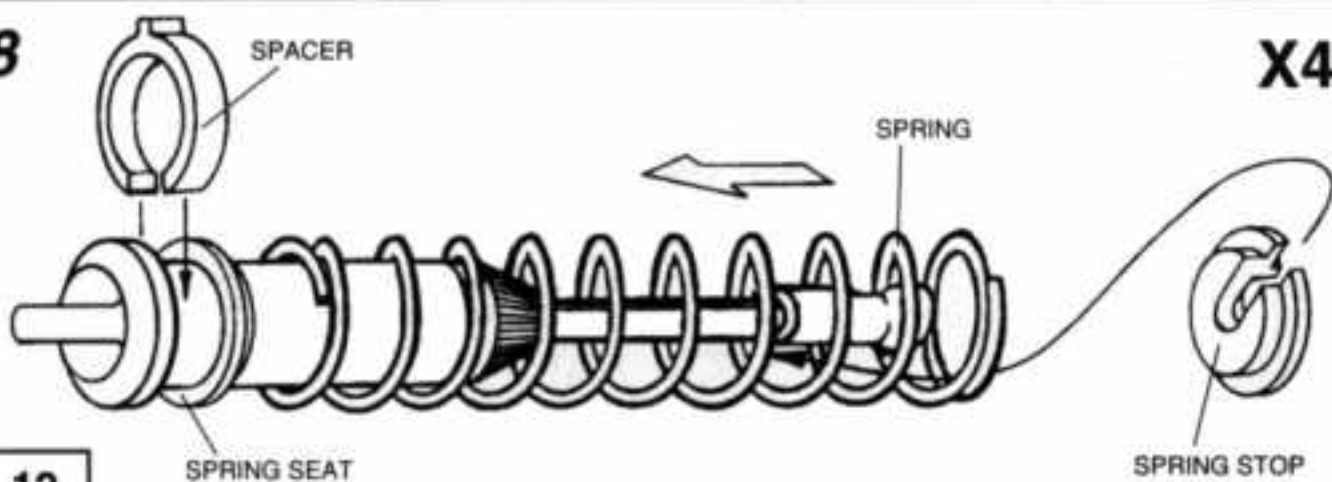

QTY REQ	PART NO	DESCRIPTION	LIST PRICE	QTY REQ	PART NO	DESCRIPTION	LIST PRICE
		<b>KITS</b>				<b>TRANSMISSION CONTINUED</b>	
<b>NEW</b>	U498Y	CAT 2000 E.C. - Euro Champ 4WD			U1504R	Washer Carrier; male, Co-Ax U/J	
	U496W	CAT 2000 - 4WD *OPEL CALIBRA*			U1505S	Washer Carrier; female, Co-Ax U/J	
		<b>BODY &amp; CHASSIS</b>			U1506T	Diff Bushings 4 x 8 x 2mm - C2000 (pr)	
	U1042W	Aerial Mount - Universal			U1507U	Diff Thrust Bearing - C2000	
	U119J	Aerial Tube			U1508V	Inboard Co-Ax U/J - C2000 (each)	
	U1403U	Wing & Side Plates - OFF ROAD			U1509W	Front Axle Co-Ax U/J-Cat 2000 (each)	
	U1406X	Chassis Gates - C2000 (pk 5)			U1510X	Rear Axle Co-Ax U/J - C2000 (each)	
	U1513A	Front Bumper - CAT2000			U1511Y	Driveshafts, Co-Ax U/J - C2000 (pr)	
	U1515C	Decal Sheet - CAT2000			U1512Z	Idler Set, Front Belt - CAT2000	
<b>NEW</b>	U1792U	Lower Chassis WFE - CAT 2000 E.C			U1526N	Diff Nut Lock - Cat 2000	
<b>NEW</b>	U1793V	Upper Chassis, WFE - CAT 2000 E.C			U1529Q	Ball Bearing - 4 x 8 x 3 Flanged (pr)	
<b>NEW</b>	U1802E	Instruction Manual - CAT2000 E.C.			U730D	Thrust Bearing 1/8" x 5/16"	
<b>NEW</b>	U1808K	Speedo Mount, WFE - CAT2000 E.C.			U855Y	Thrust Plate & Drive Hub - Slipper	
	U253J	Servo Mounts - Lay Down (pr)			U856Z	Repair Kit - Q C Slipper	
	U5037N	Undertray - Cat 2000				<b>TOURING CAR</b>	
<b>NEW</b>	U5055F	Bodyshell, "Laydown" - Cat 2000 E.C.			U1480T	Front & Rear Bulkheads - CAT2000	
	U744R	Q.C. Saddle Pack Strap (pk2)			U1487A	Rear Wishbones - CAT2000 (pr)	
	U832B	Wing Mount Kit			U1514B	Instruction Book - CAT2000/94	
		<b>SUSPENSION</b>			U1518F	Upper Chassis - WFE - CAT2000	
	U1426R	Pivot Pin-Rear Outer-C2000 2&4 (pr)			U1559U	Ultra-Short Vari Shock Absorbers (pr)	
	U1427S	Turnbuckle 540unc x 65mm (pr)			U1560V	Touring Body Mounts-Cat EC (+U1480T)	
	U1428T	Turnbuckle 540unc x 60mm (pr)			U1562X	Touring Conversion - Cat EC (+U1480T)	
	U1429U	Turnbuckle 540unc x 53mm (pr)			U1564Z	C/F Hi Response Chassis-Cat 2000	
	U1430V	Turnbuckle 540unc x 39mm (pr)			U1613W	Ultra Short Rear Spring - S16 (pr)	
	U1434Z	Rear Pivot Block-C2000 2 & 4WD (pr)			U1751F	Non Slipper Layshaft - CAT 2000	
	U1439E	Ball Bearing 5 x 9 x 3mm (pr)			U1752G	Touring Chassis, WFE - CAT2000	
	U1440F	Pivot Pin - Front Outer (pr)			U5048Y	Bodyshell - "Opel Calibra"	
	U1444J	Bush 1/8 x 1/4" (pk 4)			U6559B	*Sponges* Rear, 3 Spoke - 2000	
	U1445K	Steering Posts & Washer - C2000			U6571N	*Sponges* Front, 3 Spoke - Cat 2000	
	U1446L	Servo Saver - C2000			U786H	Body Posts - Fully adj. (pk 4)	
	U1449O	Steering Levers - Cougar2000 (pr)			U823S	QC Slipper Clutch+Gears (reqs U1497K)	
	U1450P	Track Rod & Servo Horns				<b>SPEED SECRETS - OPTION PARTS</b>	
	U1478R	Steering Yokes - CAT2000 (pr)			U1248V	Ballbearings - C2000 Steering (pk 2)	
	U1479S	Front Hub Carriers - CAT2000 (pr)			U1261I	Pozi Screw Driver No 1	
	U1481U	Front Pivot Blocks - CAT2000			U1419K	Diff Ball Bearing 4 x 8 x 2mm (pr)	
	U1484X	Front Pivot Bar - CAT2000			U1475O	Tungsten Carbide Diff Balls 4mm(pk10)	
	U1485Y	Centre Track Rod - CAT2000 set			U1476P	Tungsten Carbide Balls 1/16" (pk8)	
	U1486Z	Pivot Set - Front Hub Carrier - CAT2000			U1524L	Lexan Gear Cover - Cat 2000	
	U1490D	Pivot Pin, Rear Inner - C2000 (pr)			U1525M	Roller Drive Shaft Conversion (pr)	
	U1614X	Front Wheels, 3 Spoke CAT 2000			U1528P	Roller One Way Conv. Kit Cat 2000	
	U1615Y	Rear Wheels, 3 Spoke - 2000			U1530R	Rear Anti Roll Bar - Cat 2000	
<b>NEW</b>	U1704K	*Ball Grippa* Sockets (pk 8)			U1531S	Bump Steer Set - Cat 2000	
<b>NEW</b>	U1798A	Rear Hub Carrier - 3 deg Toe In (pr)			U1532T	Caster Blocks 5 deg - Cat 2000 (pr)	
<b>NEW</b>	U1800C	Rear Wishbones, Laydown-CAT E.C.			U1534V	Dual Rate Shock Pistons (2prs)	
<b>NEW</b>	U1801D	Front Wishbones, Laydown-CAT E.C.			U1561W	Circuit Buggy Conversion Set - Cat2000	
<b>NEW</b>	U1803F	Front Shock Mount & Brace - CAT E.C.			U1563Y	Alloy Transmission Housing - Cat 2000	
<b>NEW</b>	U1804G	Rear Shock & Wing Mount - CAT E.C.			U1566B	Wide Front Bumper - Cat 2000	
<b>NEW</b>	U750X	*Ball Grippa* Short Stud Ball Joint (8prs)			U1745Z	Front Lower Alloy Trans hsg - CAT 2000	
<b>NEW</b>	U851U	*Ball Grippa* Long Stud Ball Joint (8prs)		<b>NEW</b>	U1784M	Rear Geometry Set - CAT 2000 E.C	
		<b>TRANSMISSION</b>		<b>NEW</b>	U1785N	Laydown Susp, Set - CAT 2000 E.C	
	U1301W	Silicone Diff Grease - Tube		<b>NEW</b>	U1787P	Viscous Drive Unit - Universal	
	U1408Z	Hex Wheel Drive - C2000 2&4 (pr)		<b>NEW</b>	U1788Q	Layshaft, Viscous Drive - CAT 2000	
	U1410B	Ball Bearing - 10 x 15 x 4 (pr)		<b>NEW</b>	U1794W	C/F Lower Chassis - CAT2000 E.C.	
	U1415G	Diff Washer - 18mm C2000 (pr)		<b>NEW</b>	U1795X	C/F Upper Chassis - CAT2000 E.C.	
	U1417I	Diff Screw, Springs&Spacer - C2000		<b>NEW</b>	U1796Y	Rear Hub Carrier - 1 deg Toe In (pr)	
	U1420L	Diff Balls 4mm - Carbon Chrome (pk10)		<b>NEW</b>	U1797Z	Rear Hub Carrier - 2 deg Toe In (pr)	
	U1491E	Front Drive Belt, 170 x 4mm - CAT2000		<b>NEW</b>	U1799B	Rear Hub Carrier - 4 deg Toe In (pr)	
	U1492F	6mm Rear Drive Belt - CAT2000		<b>NEW</b>	U1805H	C/F Front Shock Mnt & Brace - CAT E.C.	
	U1493G	Motor Plate - CAT2000		<b>NEW</b>	U1806I	C/F Rear Shock & Wing Mnt - CAT E.C.	
	U1494H	Motor Heatsinks - CAT2000 (pk3)		<b>NEW</b>	U1807J	Alloy Rear Pivot Braces - CAT E.C. (pr)	
	U1496J	Motor Screw Set - CAT2000		<b>NEW</b>	U1818U	Alloy Shock Seal Housings (pr)	
	U1497K	Slipper Layshaft - CAT2000			U5041R	Flex-Wing - Moulded WHITE	
	U1498L	One Way Pulley Set - CAT2000			U818N	Ball Bearings-Roller D/Shaft pair	
	U1499M	Rear Trans Housings - CAT2000				<b>See Accessories Price List For:</b>	
	U1500N	Front Trans Housings - CAT2000				<b>SPEED PACKS - HARDWARE</b>	
	U1501O	Layshaft pulley & Flanges - CAT2000				<b>SHOCK ABSORBERS</b>	
	U1502P	18mm Diff, Assembled - CAT2000				<b>SPRINGS</b>	
	U1503Q	18mm Diff Pulley - CAT2000					

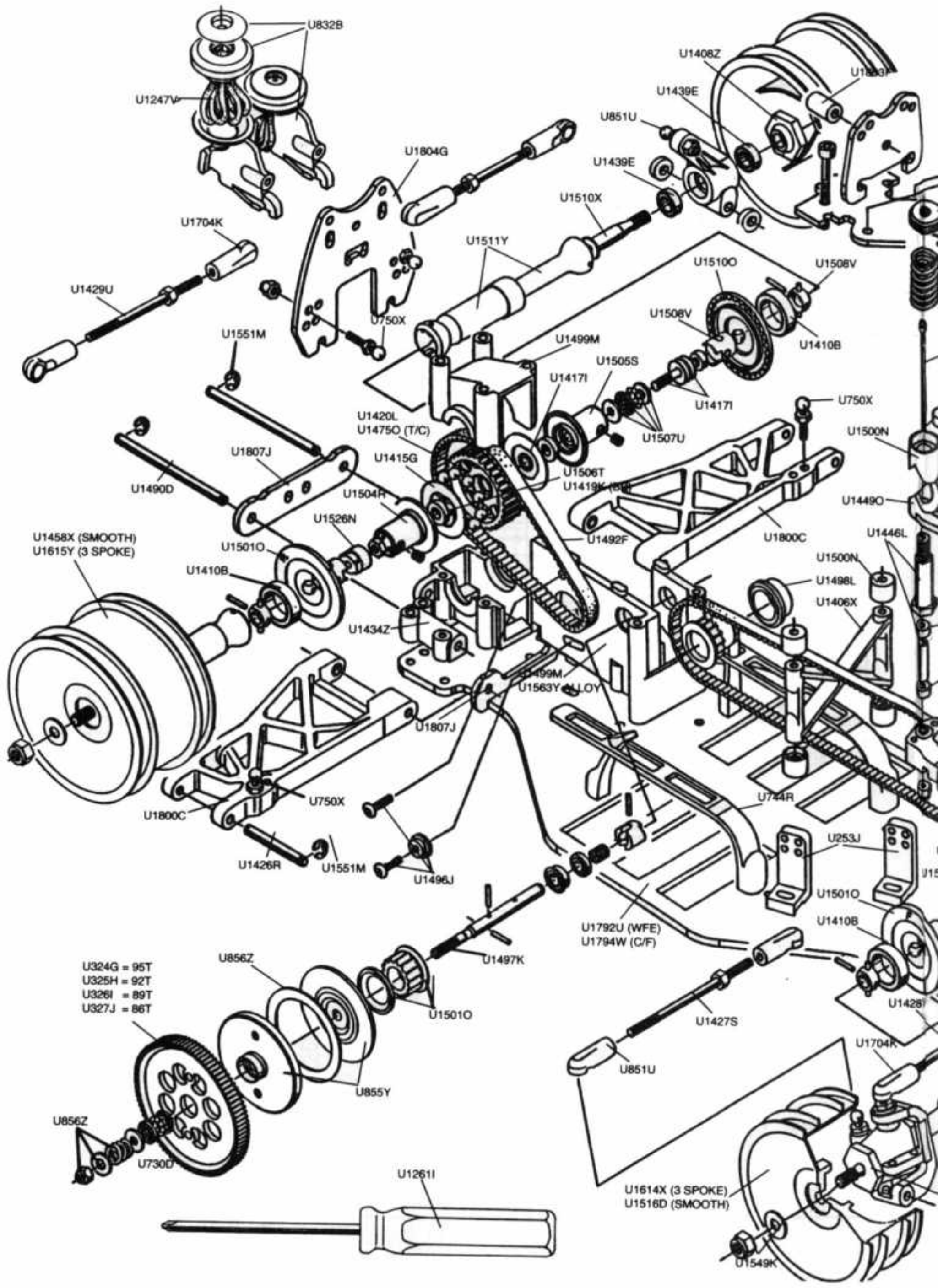

- U324G = 95T
- U325H = 92T
- U326I = 89T
- U327J = 86T

## NEW CAT 2000 EC

THE NEXT GENERATION

### SPARES DIAGRAM

ALTERNATIVES MAY BE FOUND IN THE SPARES LISTS

- U5055F BODYSHELL "LAYDOWN" - CAT 2000 EC
- U5037N UNDERTRAY - CAT 2000
- U1515C DECAL SHEET - CAT 2000
- U1802E INSTRUCTION MANUAL - CAT 2000
- U1808K SPEDO MOUNT WFE - CAT 2000 EC

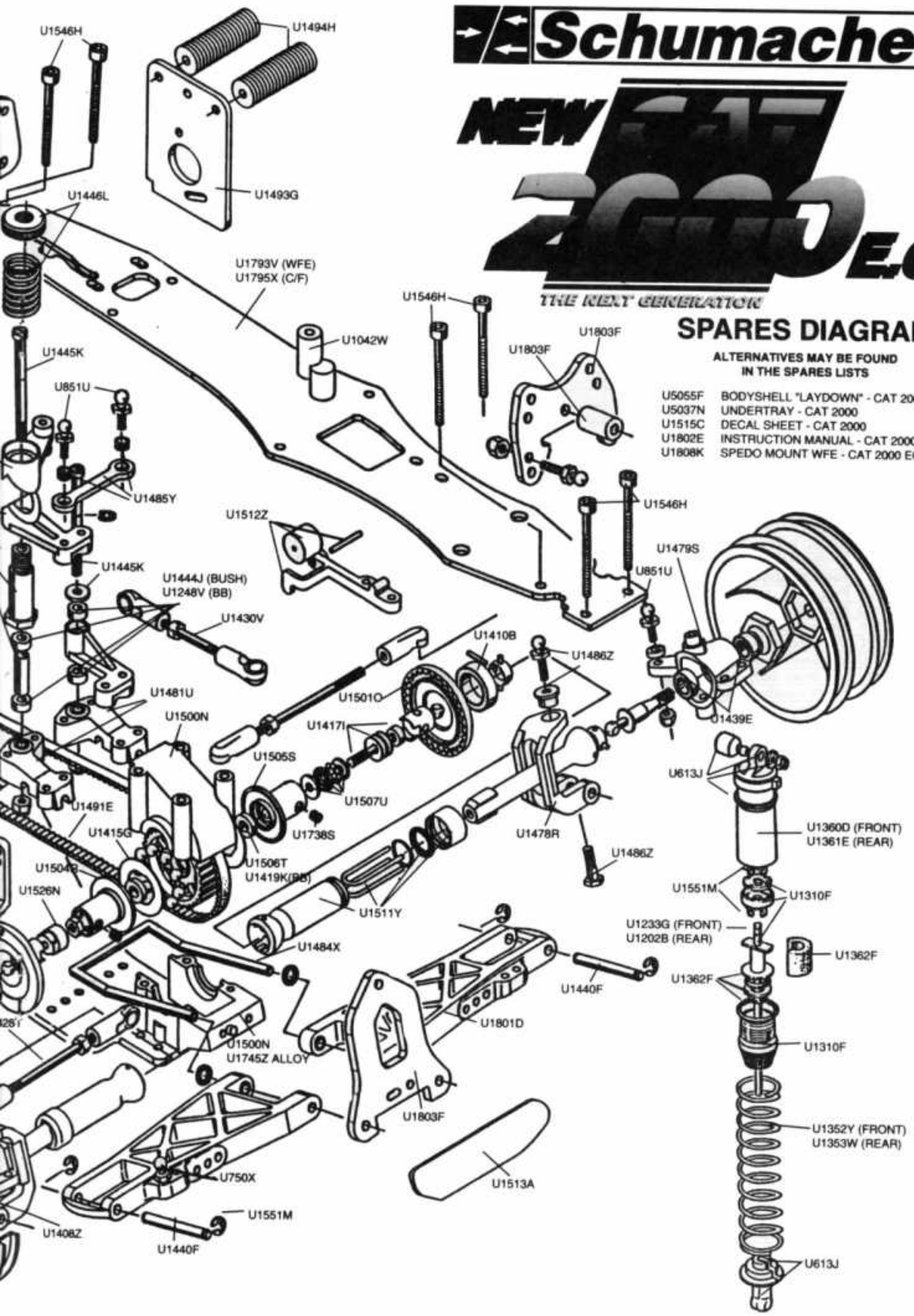

QTY REQ	PART NO	DESCRIPTION	LIST PRICE	QTY REQ	PART NO	DESCRIPTION	LIST PRICE
		<b>SPEED PACKS - HARDWARE</b>				<b>SHOCK OIL</b>	
	U1247U	SPEED PACK - Wing Mount 'O' Ring			G756I	Silicone Shock Oil - 10wt	
	U1309E	SPEED PACK-Hi-Tensile Wheel Screws			G757J	Silicone Shock Oil - 15wt	
	U1537Y	SPEED PACK - Short Self Tap Pan			G758K	Silicone Shock Oil - 20wt	
	U1538Z	SPEED PACK - Long Self Tap Pan			G759L	Silicone shock Oil - 25wt	
	U1539A	SPEED PACK - Self Tap Csk Hd			G760M	Silicone Shock Oil - 30wt	
	U1540B	SPEED PACK - Short M3 Pan Hd			G761N	Silicone Shock Oil - 35wt	
	U1541C	SPEED PACK - Medium M3 Pan Hd			G762O	Silicone Shock Oil - 40wt	
	U1542D	SPEED PACK - Long M3 Pan Hd			G763P	Silicone Shock Oil - 80wt	
	U1543E	SPEED PACK - M3 Csk Hd				<b>ACCESSORIES</b>	
	U1544F	SPEED PACK - Short M3, Cap Hd			U058A	Nicad Clamps (Pair)	
	U1545G	SPEED PACK - Medium M3 Cap Hd			U1042W	Aerial Mount - Universal	
	U1546H	SPEED PACK - Long M3 Cap Hd			U1194U	98T "Whisper" Gear - 48 D.P.	
	U1547I	SPEED PACK - M3 Nuts			U1195V	98T Q.C. Slipper Gear - 48 D.P.	
	U1548J	SPEED PACK - M3 Washers			U119J	Aerial Tube	
	U1549K	SPEED PACK - M4 Nuts & Washers			U122M	Velcro 1/2metre x 10mm.	
	U1550L	SPEED PACK - Socket Wrenches (pk3)			U1261I	Pozi Screw Driver No 1	
	U1551M	SPEED PACK - *E* Clips 1/8" (pk8)			U1276X	M4 x 35mm Turnbuckle Adjuster pair	
	U1552N	SPEED PACK - *R* Clips (pk8)			U1403U	Wing & Side Plates - OFF ROAD	
	U1565A	SPEED PACK - Small Self Tap, PanHd			U1427S	Turnbuckle 540unc x 65mm (pr)	
	U1606P	SPEED PACK - Servo Tape			U1428T	Turnbuckle 540unc x 60mm (pr)	
	U1633Q	SPEED PACK - Needle Rollers (pk)			U1429U	Turnbuckle 540unc x 53mm (pr)	
	U1700G	SPEED PACK - M4 x 12 Csk Unbrako (pk4)			U1430V	Turnbuckle 540unc x 39mm (pr)	
	U1738S	SPEED PACK - Grub-Set Screws (pk)			U1697D	Stick Nicad Straps - Bosscat (pr)	
	U1769X	SPEED PACK - Large Self Taps (pk8)		<b>NEW</b>	U1704K	*Ball Grippa* Sockets (pk 8)	
	U1770Y	SPEED PACK - M5 x 14mm Screws (pk4)			U229L	95T "Whisper" Gear - 48 D.P.	
	U1771Z	SPEED PACK - Tywraps (pk8)			U230M	92T "Whisper" Gear - 48 D.P.	
	U1779H	SPEED PACK - 4 X 40 UNC screws			U231N	89T "Whisper" Gear - 48 D.P.	
		<b>SHOCK ABSORBERS</b>			U232O	86T "Whisper" Gear - 48 D.P.	
	U1202B	Piston Rod - Long Shock (pr)			U233P	19T PINION - 48 D.P.	
	U1233G	Piston Rod - Med Shock (pr)			U234Q	22T PINION - 48 D.P.	
	U1258F	Piston Rod, Short Shock (pr)			U235R	25T PINION - 48 D.P.	
	U1272T	Vari Shock Body - Short (each)			U236S	28T PINION - 48 D.P.	
	U1273U	Vari Shock Body - Medium (each)			U253J	Servo Mounts - Lay Down (pr)	
	U1274V	Vari Shock Body - Long (each)			U254K	Nicad Holder - Stick Pack 1	
	U1310F	Shock Mouldings-Vari Click Piston (pr)			U324G	95T QC Slipper Gear - 48 DP	
	U1356Z	Pro-Shock Absorbers - Short (pr)			U325H	92T QC Slipper Gear - 48 DP	
	U1357A	Pro-Shock Absorbers - Medium (pr)			U326I	89T QC Slipper Gear - 48 DP	
	U1358B	Pro-Shock Absorbers - Long (pr)			U327J	86T QC Slipper Gear - 48 DP	
	U1359C	Pro-Shock Body - Short (each)			U5041R	Flex-Wing - Moulded WHITE	
	U1360D	Pro-Shock Body - Medium each			U636G	M3 Ball Joints Bag (pk4)	
	U1361E	Pro-Shock Body - Long each			U717Q	Adjustable Servo Link (2 sets)	
	U1362F	Pro-Shock Seal Pack (pr)			U728B	Rose Joints M3 - Short (pk 4)	
	U1534V	Dual Rate Shock Pistons (2prs)			U743Q	Q.C. Saddle Pack Tray & Strap (pr)	
	U1557S	Ultra-Short Shock Rod (pr)			U744R	Q.C. Saddle Pack Strap (pk2)	
	U1558T	Ultra-Short Shock Body (each)		<b>NEW</b>	U750X	*Ball Grippa* Short Stud Ball Joint (8prs)	
	U1559U	Ultra-Short Vari Shock Absorbers (pr)			U786H	Body Posts - Fully adj. (pk 4)	
	U5023Z	Vari Shock Absorbers - Short (pr)			U796R	Turnbuckle Adjuster - 24mm (pk2)	
	U5024A	Vari Shock Absorbers - Medium (pr)			U797S	Turnbuckle Adjuster-35mm (pk2)	
	U5025B	Vari Shock Absorbers - Long (pr)			U798T	Turnbuckle Adjuster-45mm (pk2)	
	U613J	Spring Stop & Spacer Mouldings (pr)			U799U	Rear Suspension Pivots - 2mm 3prs	
	U835E	Shock Seal Pack - standard (pr)			U822R	Rose Joints M3 - Long pk4	
		<b>SPRINGS</b>			U832B	Wing Mount Kit	
	U1351U	Short Spring Tuning Set-Colour (4prs)		<b>NEW</b>	U851U	*Ball Grippa* Long Stud Ball Joint (8prs)	
	U1352V	Med Spring Tuning Set-Colour (4prs)				<b>TITANIUM</b>	
	U1353W	Long Spring Tuning Set-Colour (4prs)			U1572H	Titanium Turnbuckle 39mm (pr)	
	U1366J	Ultra Short Rear Spring - S24 (pr)			U1573I	Titanium Turnbuckle 53mm (pr)	
	U1380X	White Shock Springs-Med; rate 1.5 (pr)			U1574J	Titanium Turnbuckle 60mm (pr)	
	U1381Y	White Shock Springs-Long; rate 1.5 (pr)			U1575K	Titanium Turnbuckle 65mm (pr)	
	U1382Z	Yellow Shock Springs-Long; rate 2 (pr)			U1576L	Titanium Pivot Pin 25mm (pr)	
	U1383A	Grey Shock Springs - Long; rate 3 (pr)			U1577M	Titanium Pivot Pin 29mm (pr)	
	U1384B	Blue Shock Springs - Long; rate 4 (pr)			U1578N	Titanium Pivot Pin 42mm (pr)	
	U1385C	Yellow Shock Springs - Med; rate 2 (pr)			U1579O	Titanium Pivot Pin 44mm (pr)	
	U1386D	Grey Shock Springs - Med; rate 3 (pr)			U1580P	Titanium Pivot Pin 48mm (pr)	
	U1387E	Blue Shock Springs - Med; rate 4 (pr)				<b>BODYSHELLS</b>	
	U1388F	Black Shock Springs - Med; rate 6 (pr)			U5021X	Bodyshell - *Storm* Racing Truck	
	U1389G	Yellow Shock Spring - Short; rate 2 (pr)			U5032I	Bodyshell - *1992 Celica*	
	U1390H	Grey Shock Springs - Short; rate3 (pr)			U5033J	Bodyshell - Rally *Escort Cosworth*	
	U1391I	Blue Shock Springs - Short; rate 4 (pr)			U5047X	Bodyshell - *Alfa Romeo 155*	
	U1392J	Black Shock Springs - Short; rate 6 (pr)			U5048Y	Bodyshell - *Opel Calibra*	
	U1613W	Ultra Short Rear Spring - S16 (pr)			U5049Z	Bodyshell - *Mercedes C-Class*	

**9 FITTING FRONT SHOCK ABSORBERS**

**ECS**

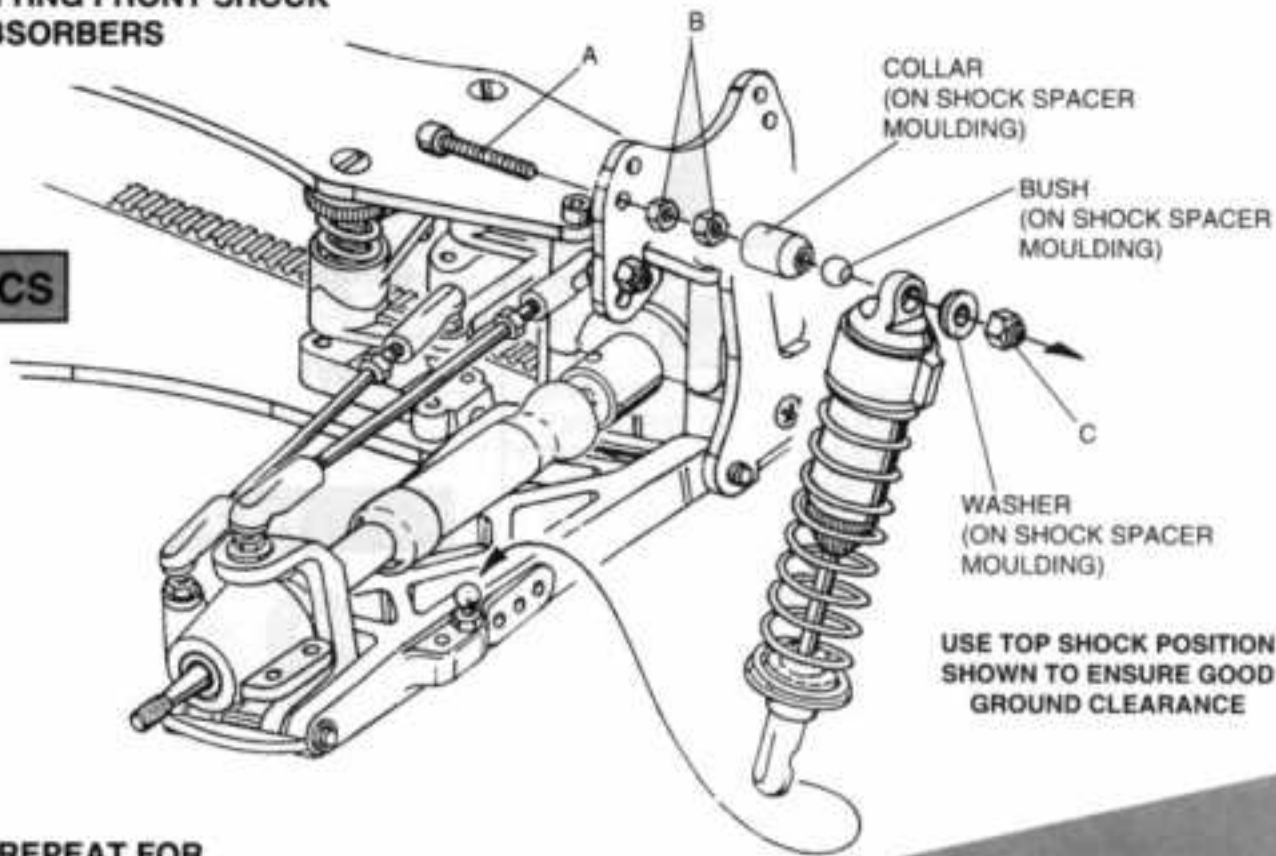

REPEAT FOR LEFT SIDE

**EC**

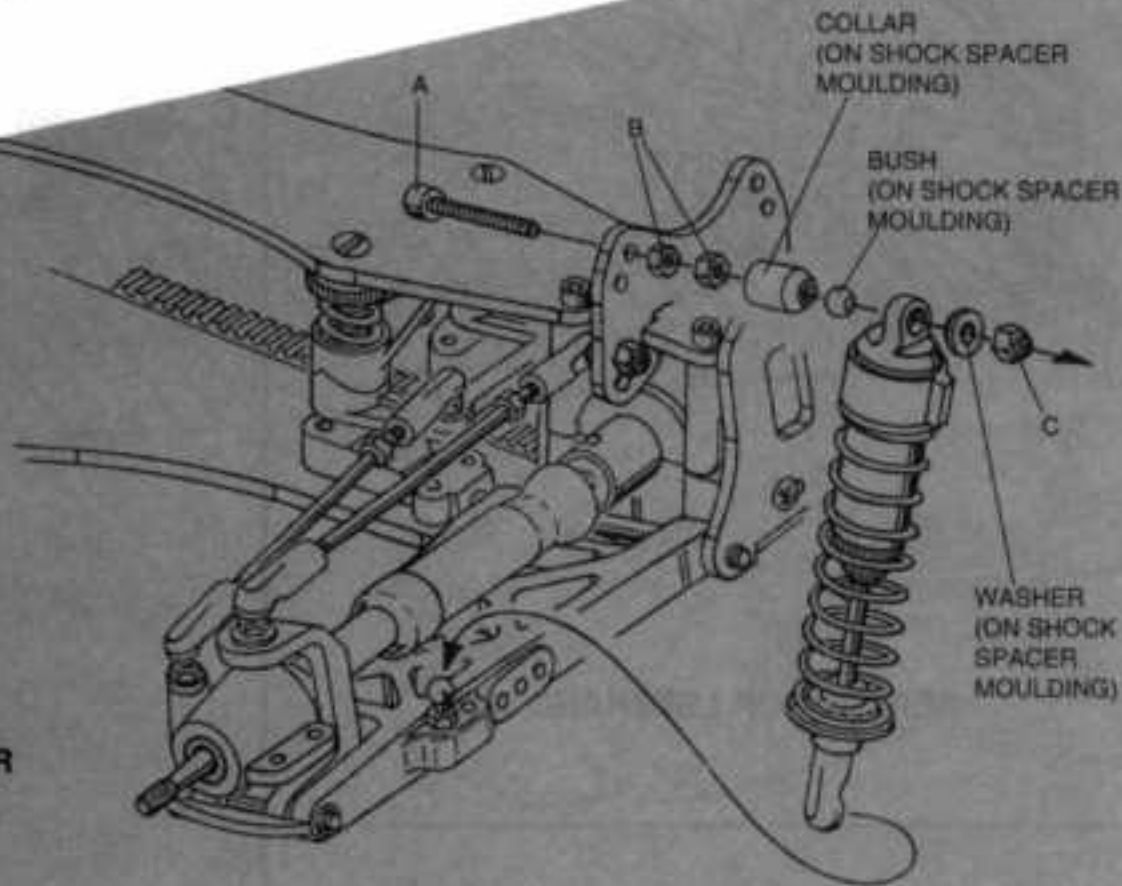





REPEAT FOR LEFT SIDE

**Schumacher**

**NEW FAT 2000 E.C.**  
THE NEXT EVOLUTION

**SHOCK ABSORBERS**

**HARDWARE**

- A**  X4  
M3 x 20mm CAPHEAD SCREW
- B**  X8  
M3 NUT
- C**  X5  
M3 NYLOC NUT
- D**  X1  
M3 x 20mm PANHEAD SCREW

**10 FITTING REAR SHOCK ABSORBERS**

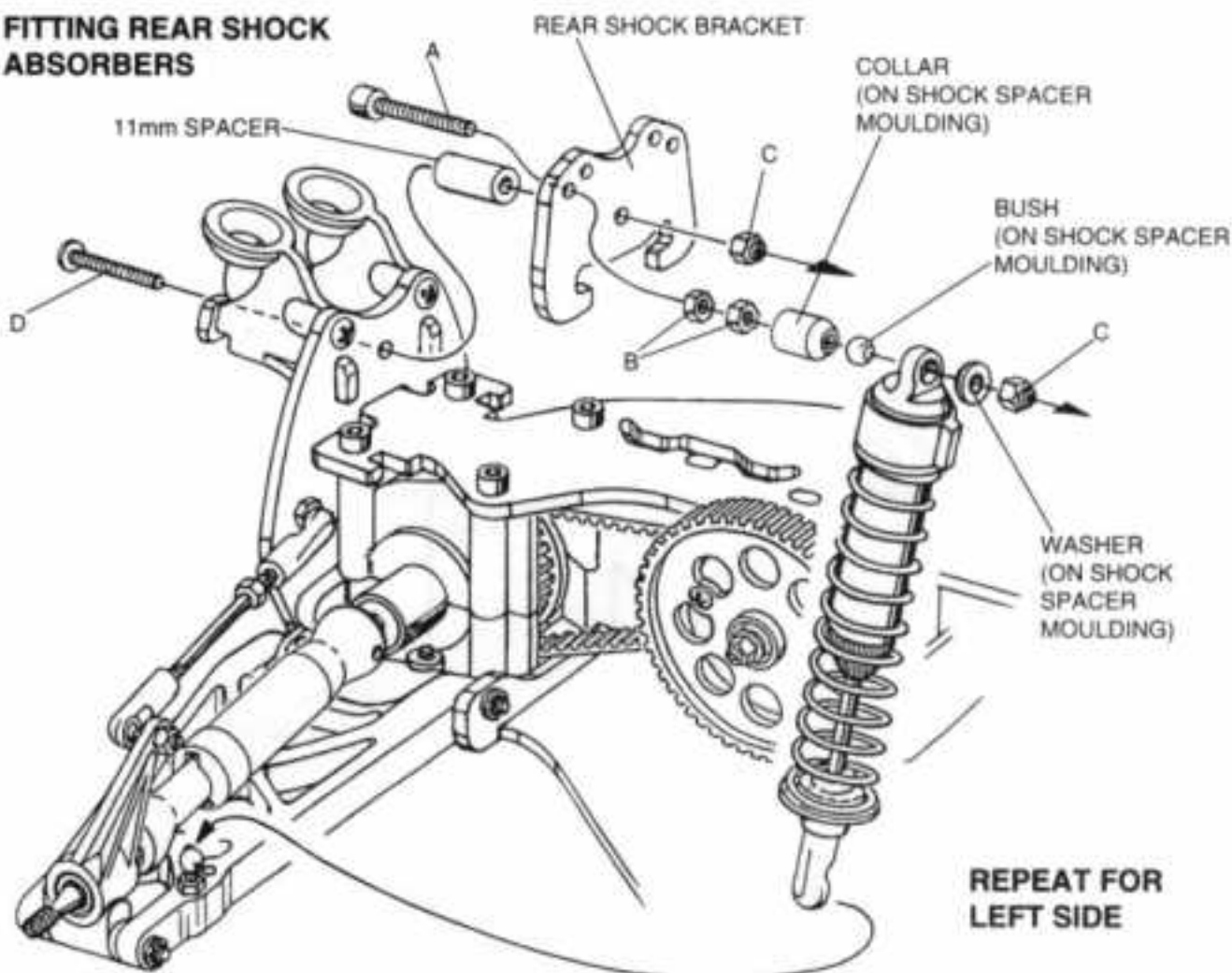

REPEAT FOR LEFT SIDE

**NOTE:**

SQUEEZE BALL GRIPPA SOCKETS WITH PLIERS UNTIL YOU GET FREE MOVEMENT OF FRONT & REAR SUSPENSION



**1 FITTING TYRES TO WHEELS**  
 MAKE SURE TYRE BEAD SEATS PROPERLY IN GROOVES OF WHEEL

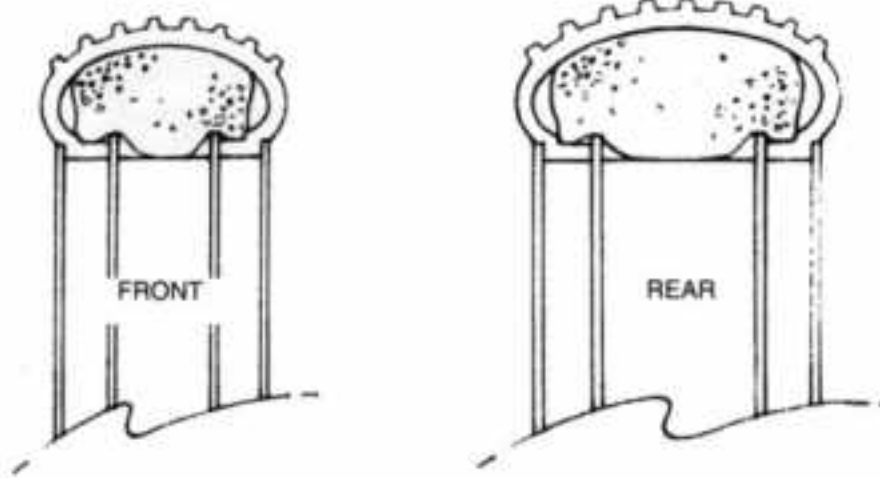

**EC**

THE CAT 2000 EC USES SOFT COMPOUND TYRES AND NEEDS FOAM TYRE INSERTS. SECURE TYRES IN PLACE USING SUPER-GLUE.

**ECS**

THE CAT 2000 ECS USES HARDER COMPOUND TYRES AND DOES NOT NEED FOAM INSERTS OR GLUE TO HOLD THE TYRES TO THE WHEEL RIMS.

**Schumacher**

**NEW CAT 2000 EC**  
 THE BEST PERFORMANCE

**WHEEL & TYRES**

**BAG 6**

**HARDWARE**

**2 FITTING FRONT WHEELS**

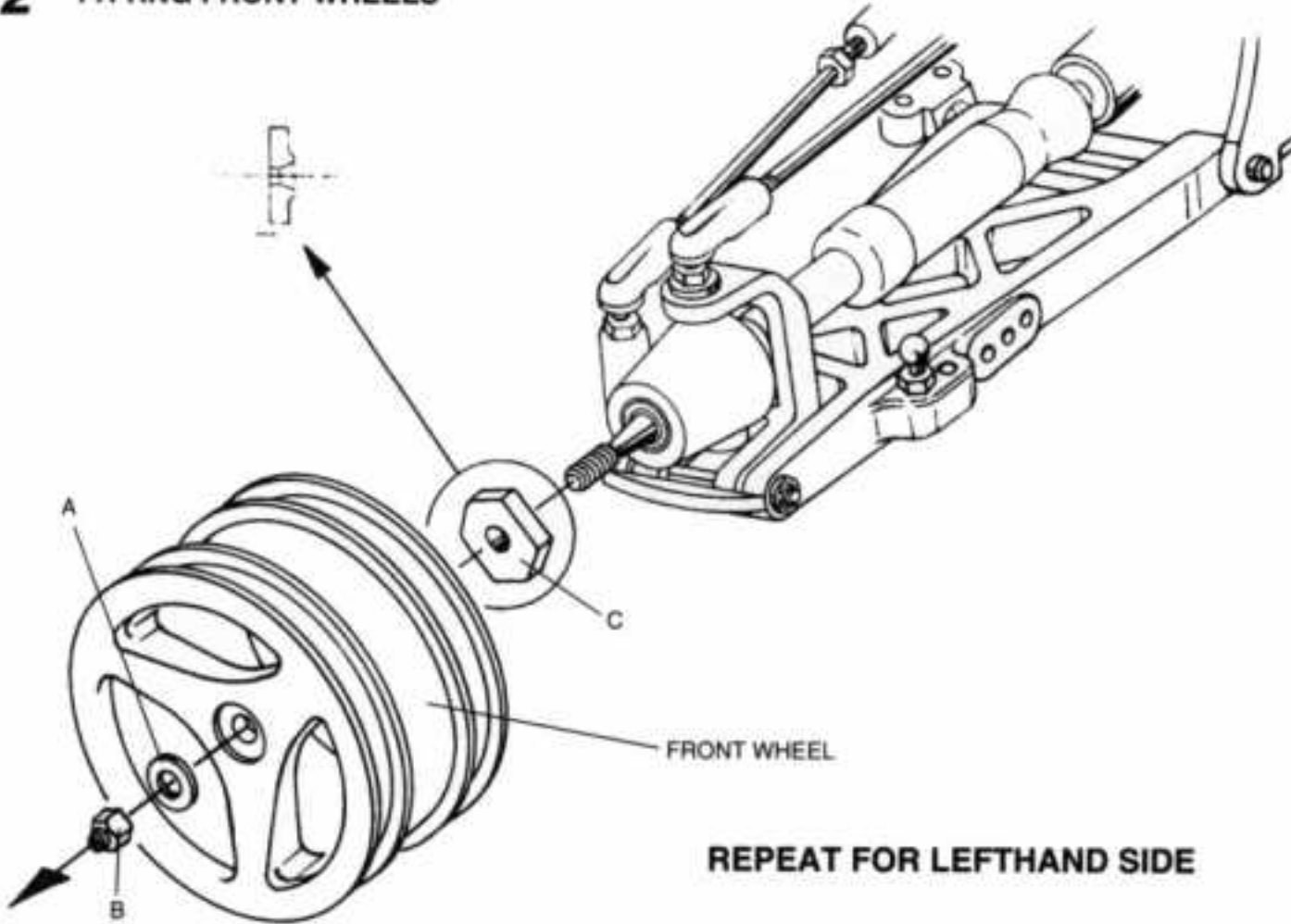

**A**  X4  
 M4 STEEL WASHER

**B**  X4  
 M4 STEEL WASHER

**C**  X4  
 HEX DRIVE PLATE - NARROW

**3 FITTING REAR WHEELS**

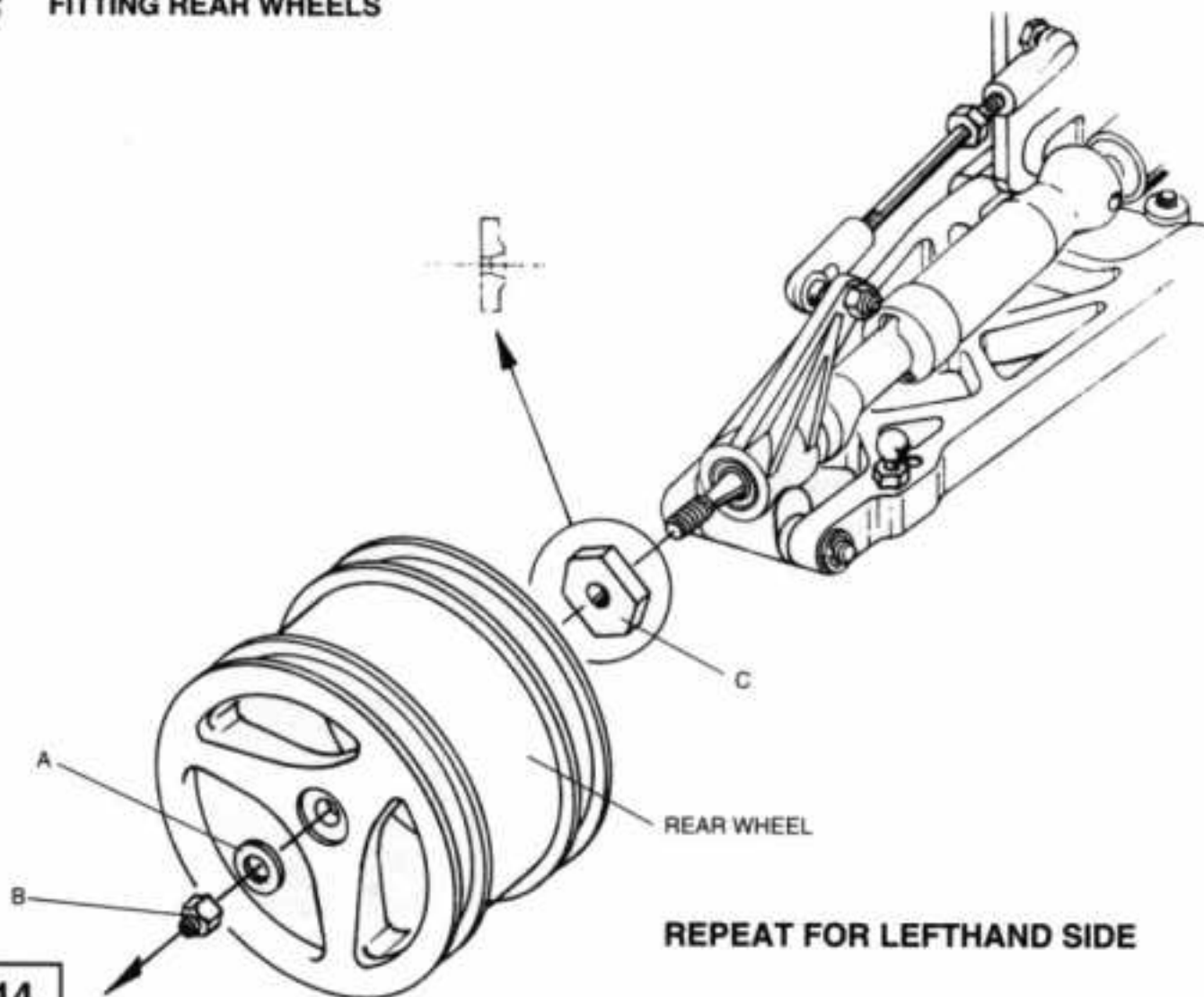

**BODYSHELL**

CUT AWAY SHADED AREAS.

USE A FILE OR ABRASIVE PAPER TO SMOOTH THE CUT EDGES. ANY RAGGED EDGES OR SCORE LINES MAY CAUSE THE BODYSHELL TO CRACK OR SPLIT WHEN IN USE.

**PAINTING:** FIRST WASH THE BODYSHELL TO REMOVE ANY OIL OR DIRT. RINSE THOROUGHLY. PAINT THE INSIDE OF THE BODYSHELL AND WING. YOU CAN OBTAIN A COLOUR SCHEME BY MASKING A SECTION WITH TAPE, PAINTING, THEN REMOVING THE TAPE AND PAINTING A DIFFERENT COLOUR.

APPLY THE DARKEST COLOUR FIRST.

USE DECALS TO FINISH YOUR BODYSHELL.

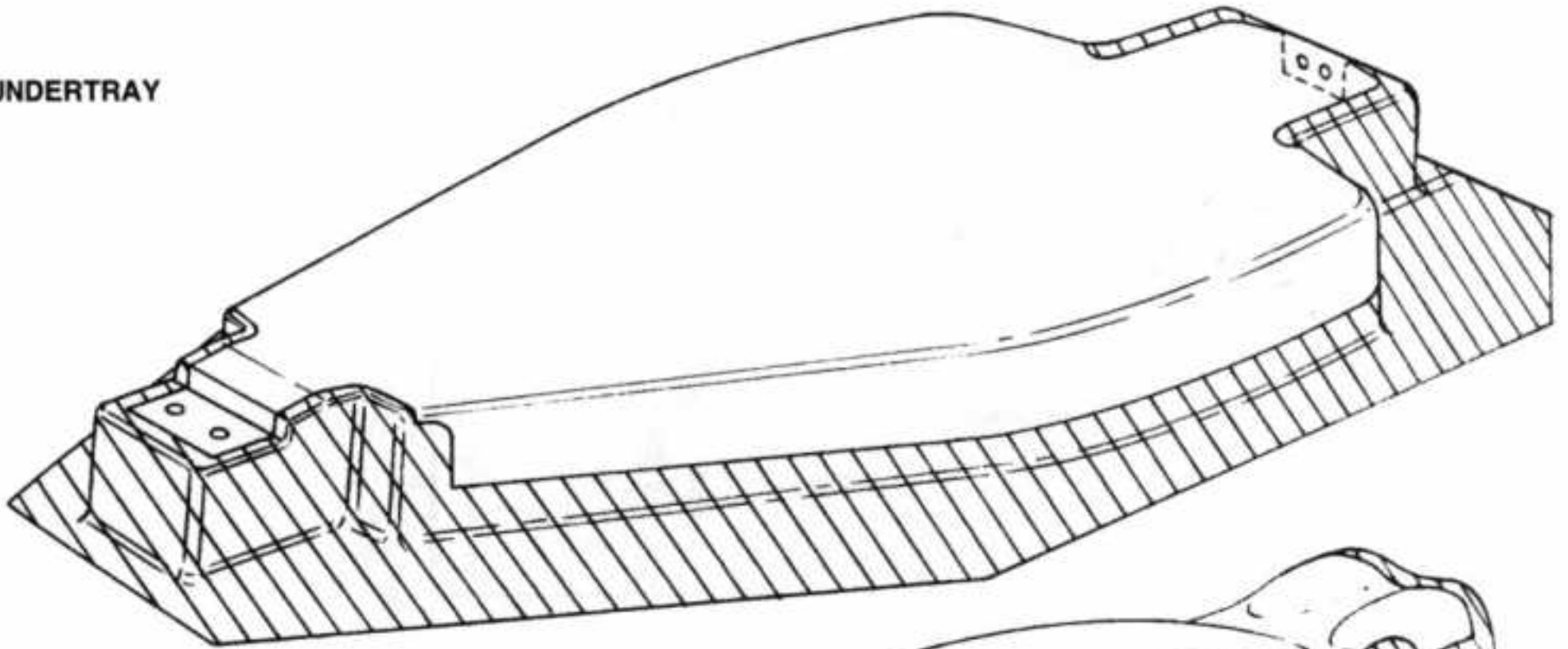
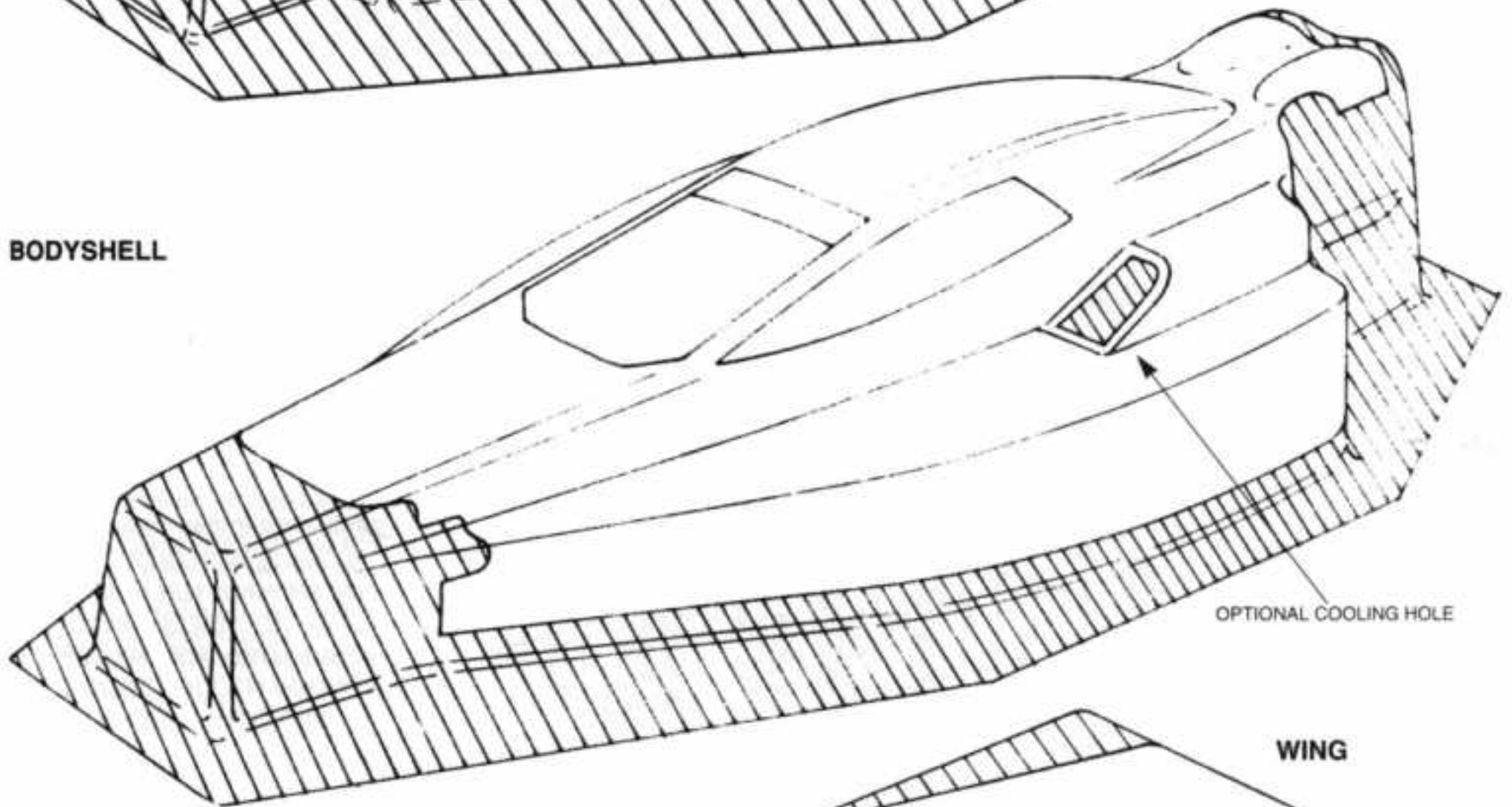
**UNDERTRAY****BODYSHELL**

2 HOLES  
8mm DIA

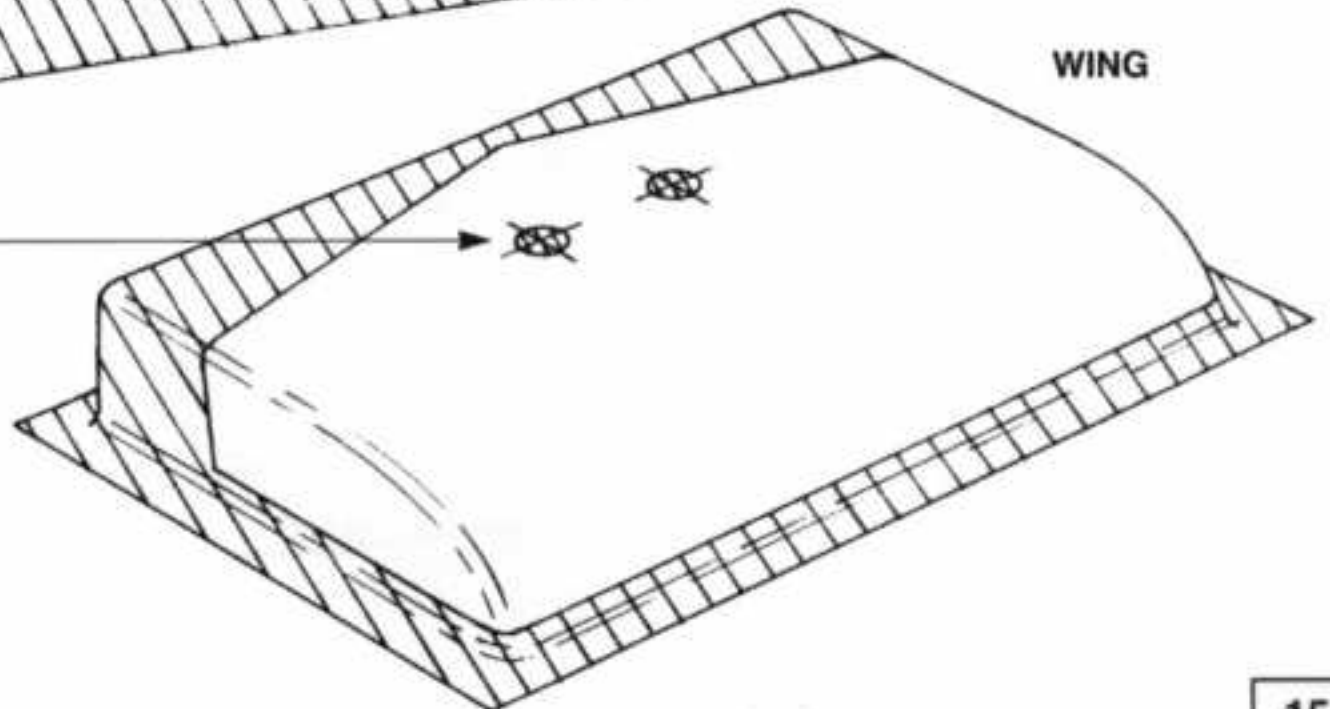

**WARNING:** MOTOR CLEANING SOLVENTS WILL PERMANENTLY DAMAGE THE POLYCARBONATE BODYSHELL & UNDERTRAY. ALWAYS REMOVE MOTOR BEFORE DOING ANY MAINTENANCE

**FITTING FRONT BUMPER & UNDERTRAY**

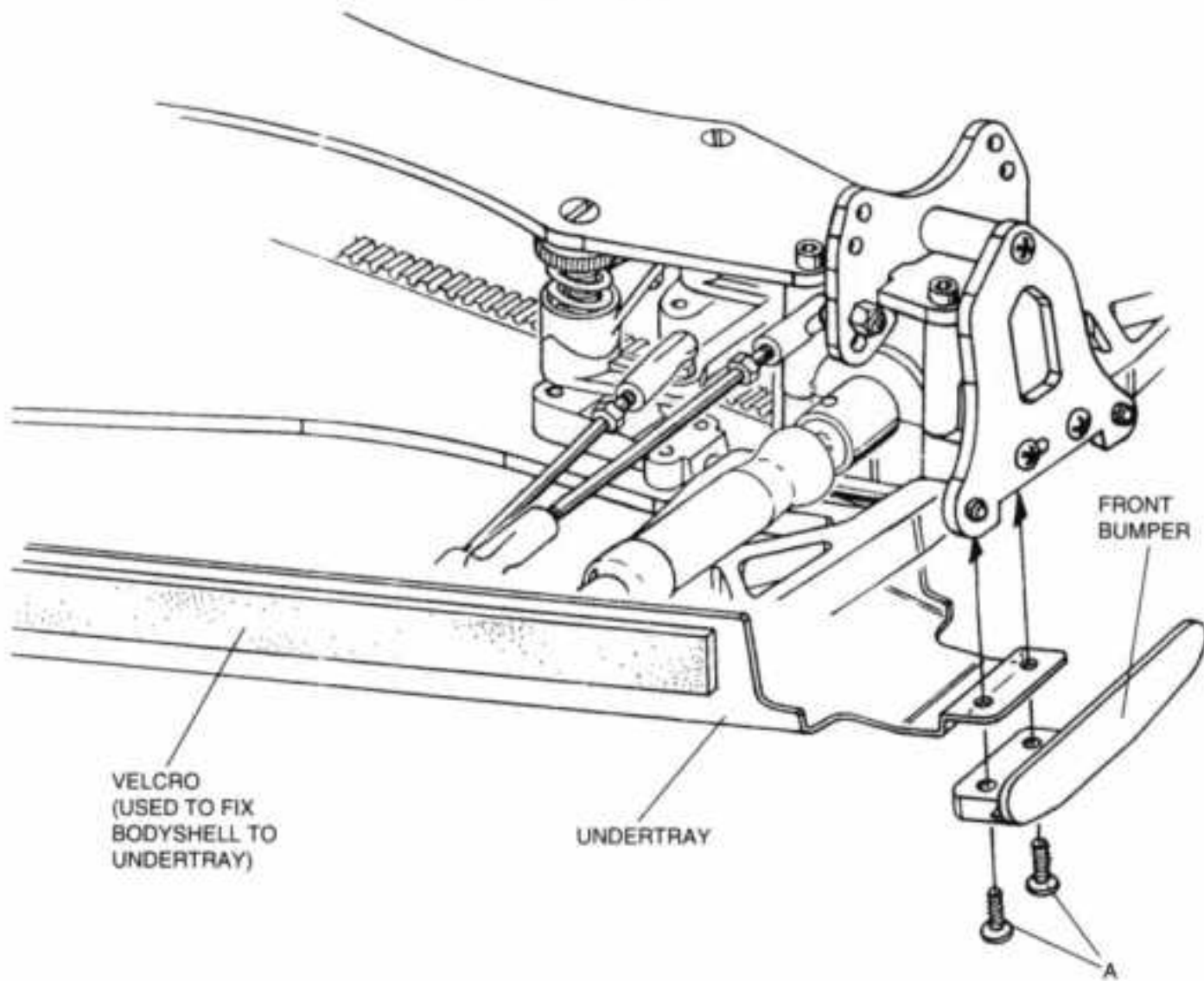

**BUMPER & UNDERTRAY**

**BAG 6**

**HARDWARE**

- A**  X2  
No4 x 3/8" SELFTAP PANHEAD SCREW
- B**  X2  
No4 x 1/4" SELFTAP PANHEAD SCREW

**FITTING UNDERTRAY AT REAR & DIFF GUARD**

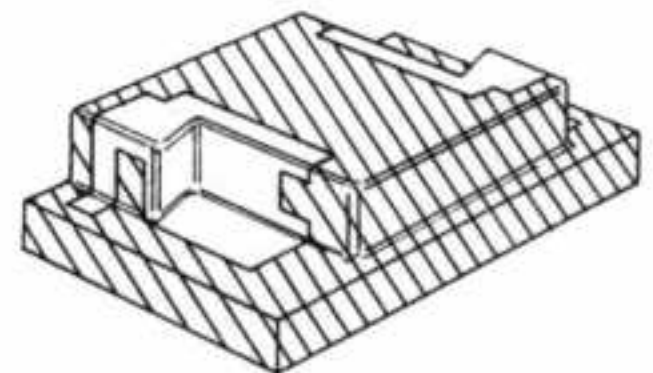
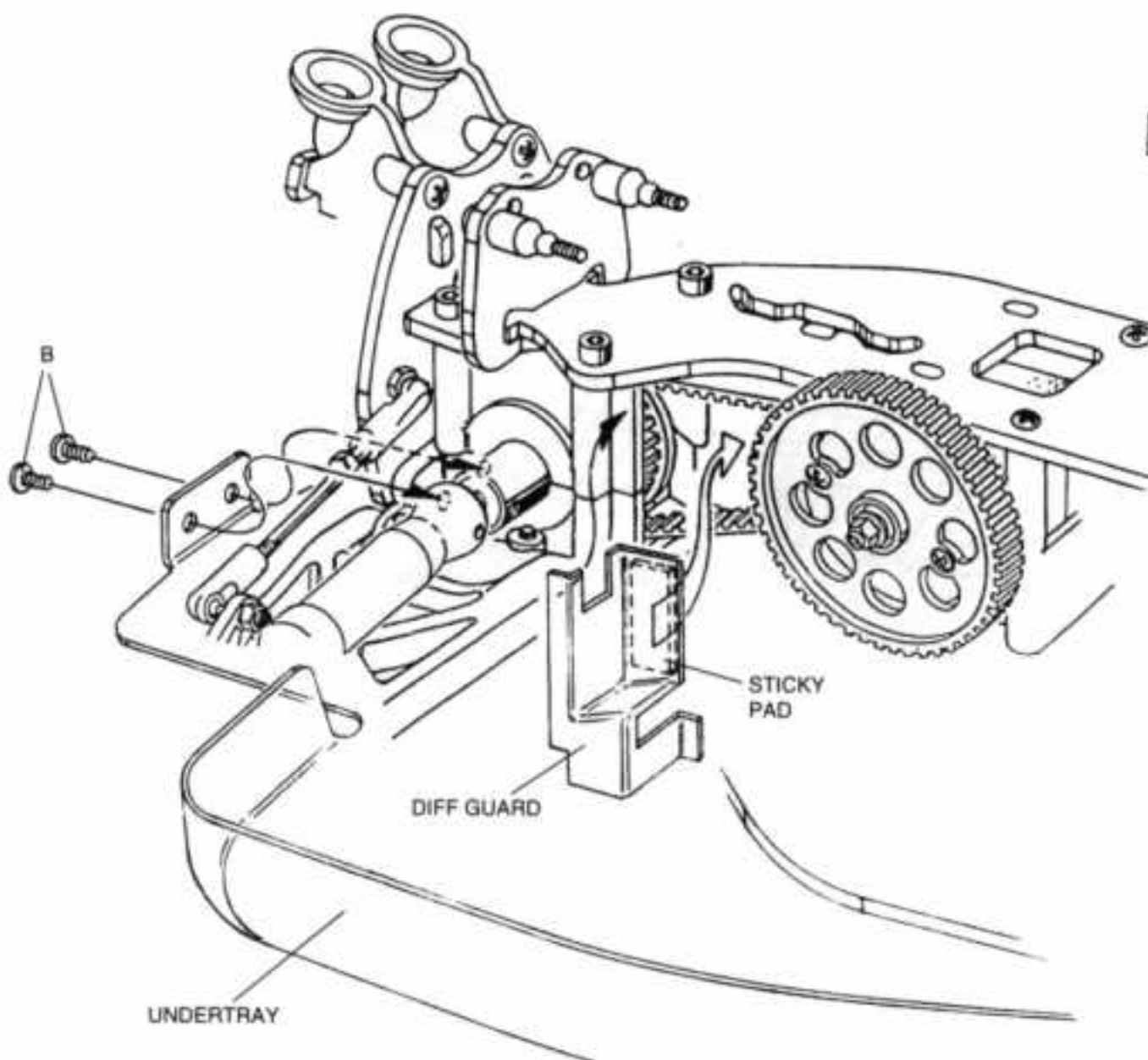

THERE ARE 2 DIFF GUARDS (THEY ARE BOTH THE SAME) CUTAWAY SHADED AREAS. IT IS IMPORTANT TO TRIM THIS PART VERY CAREFULLY. THE BETTER THE LEXAN GUARD FITS THE LESS CHANCE OF STONES GETTING INTO THE DIFF.

**REAR WING**

**HARDWARE**

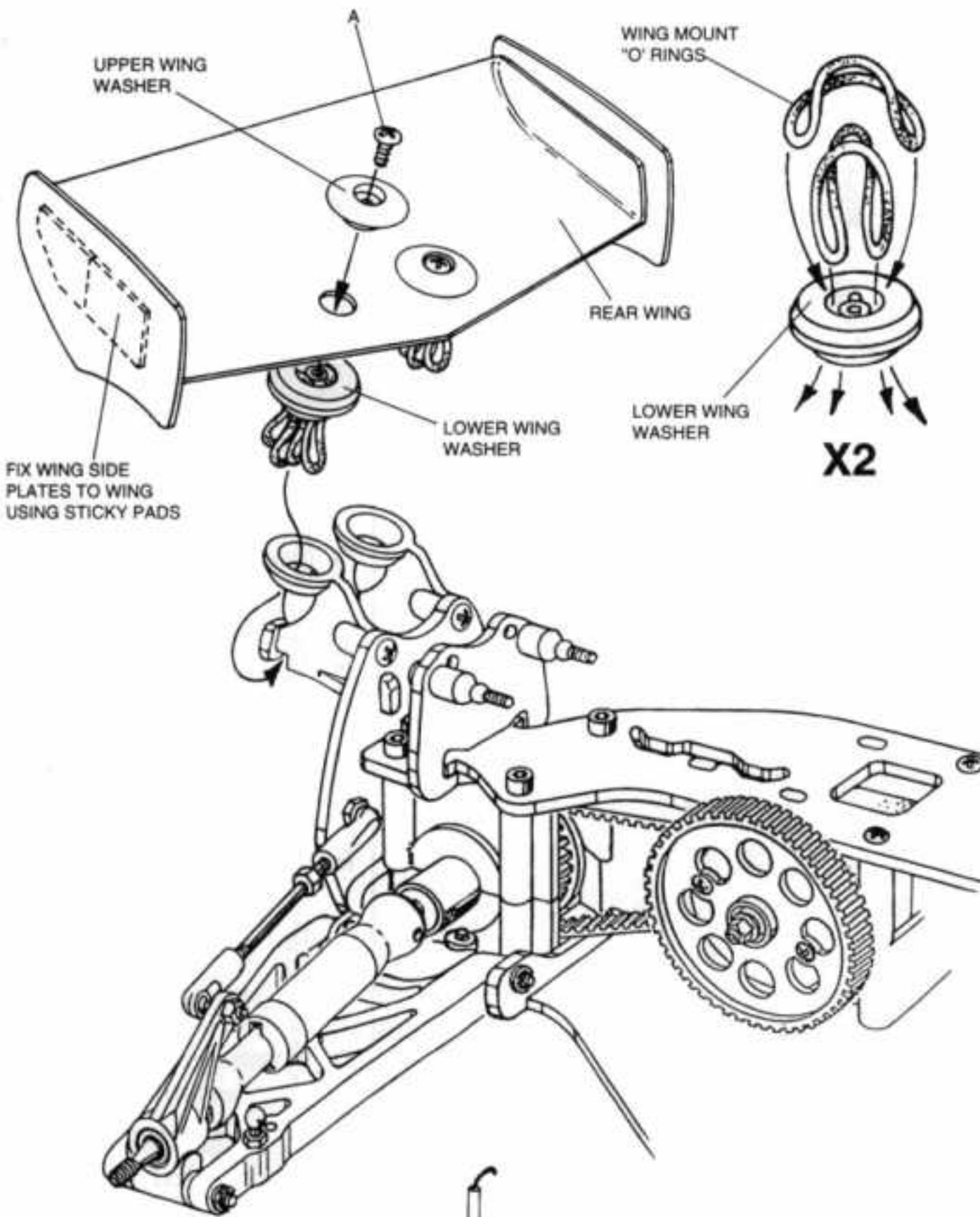

- B**  X2  
No4 x 1/4" SELFTAP PANHEAD SCREW

**CONSULT THE INDIVIDUAL INSTRUCTION SHEETS SUPPLIED WITH YOUR OWN RADIO CONTROL EQUIPMENT AND SPEED CONTROLLER WHEN FITTING INTO CAR**

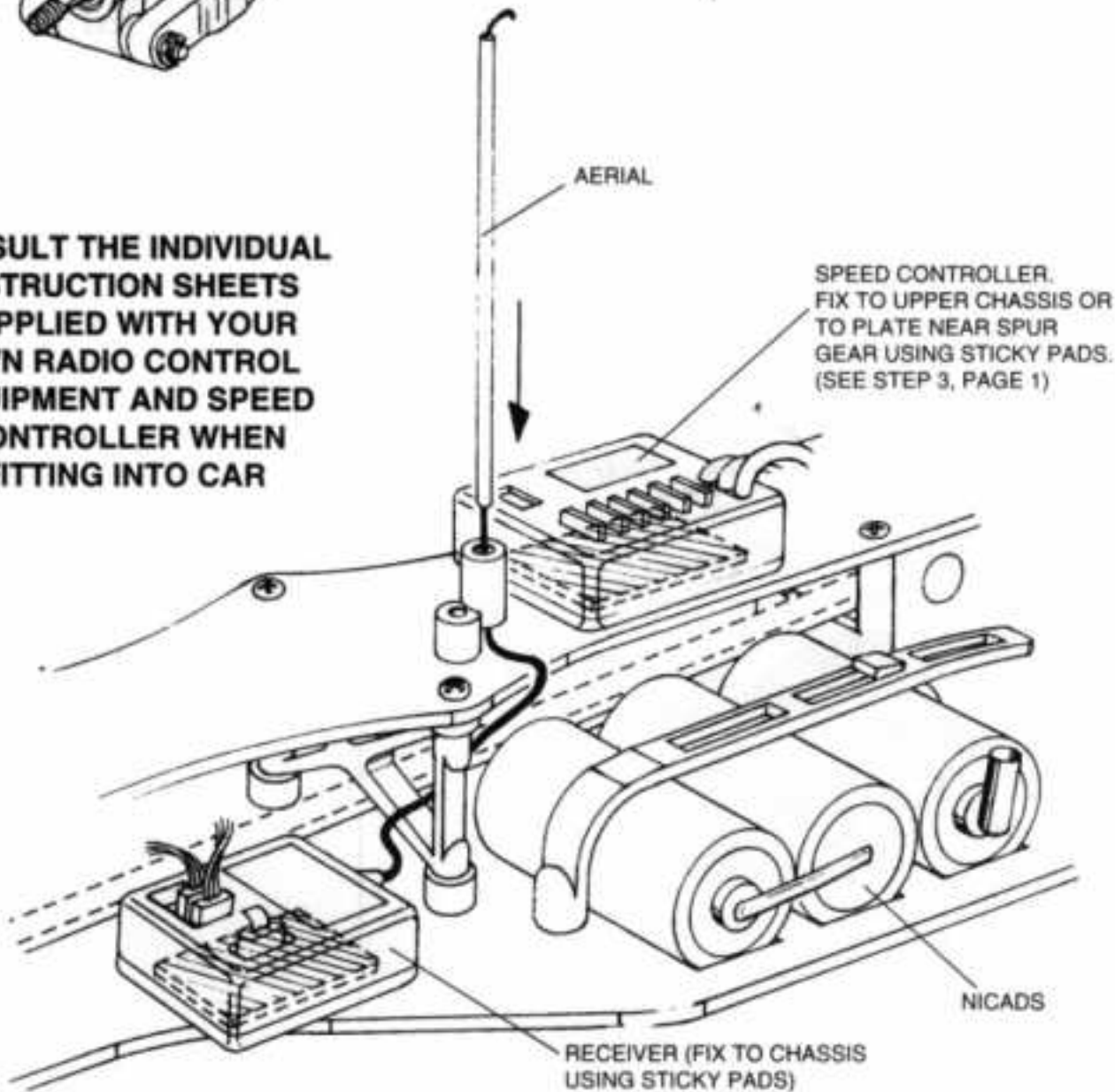

## FITTING SERVO

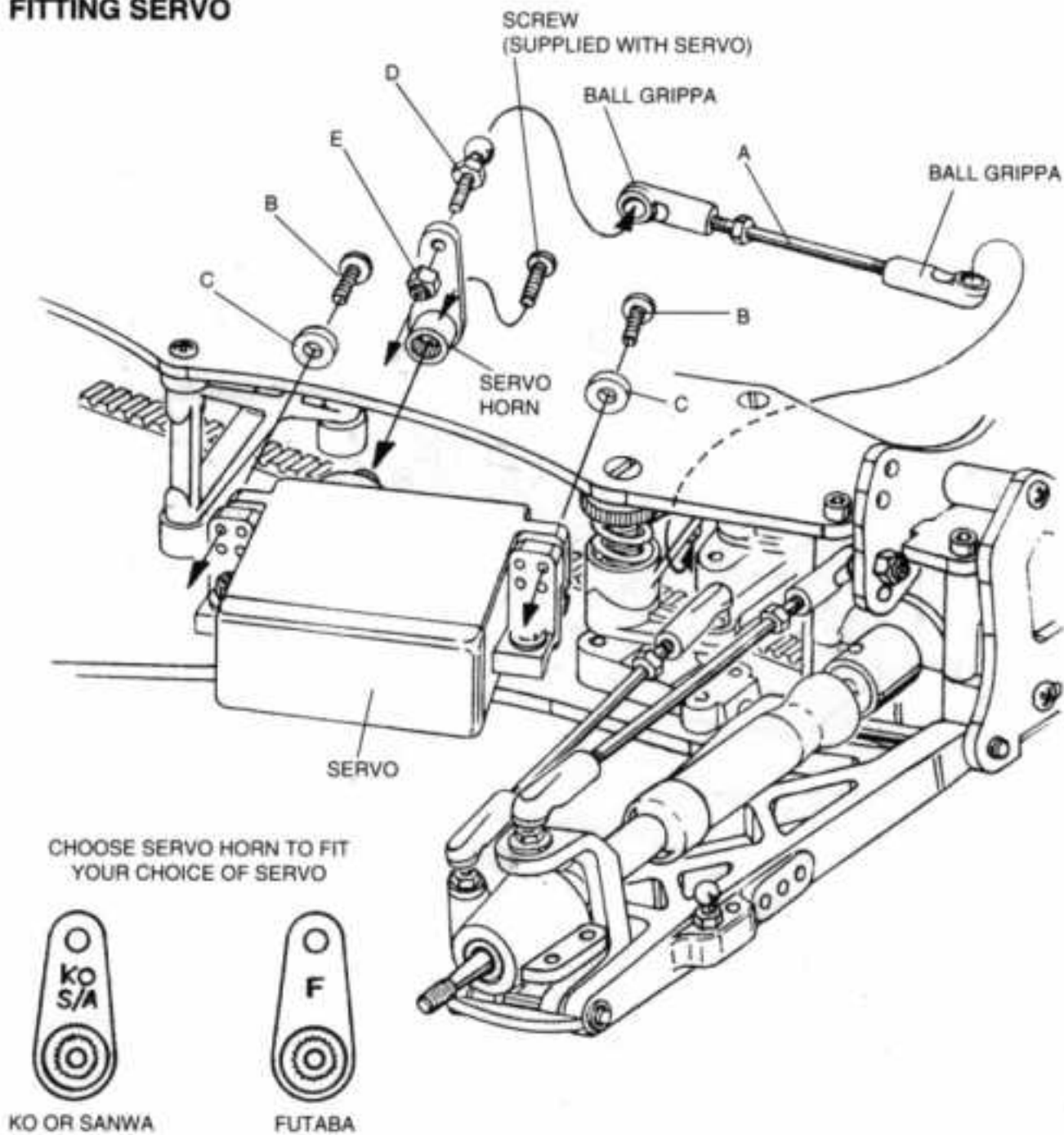

## FITTING MOTOR

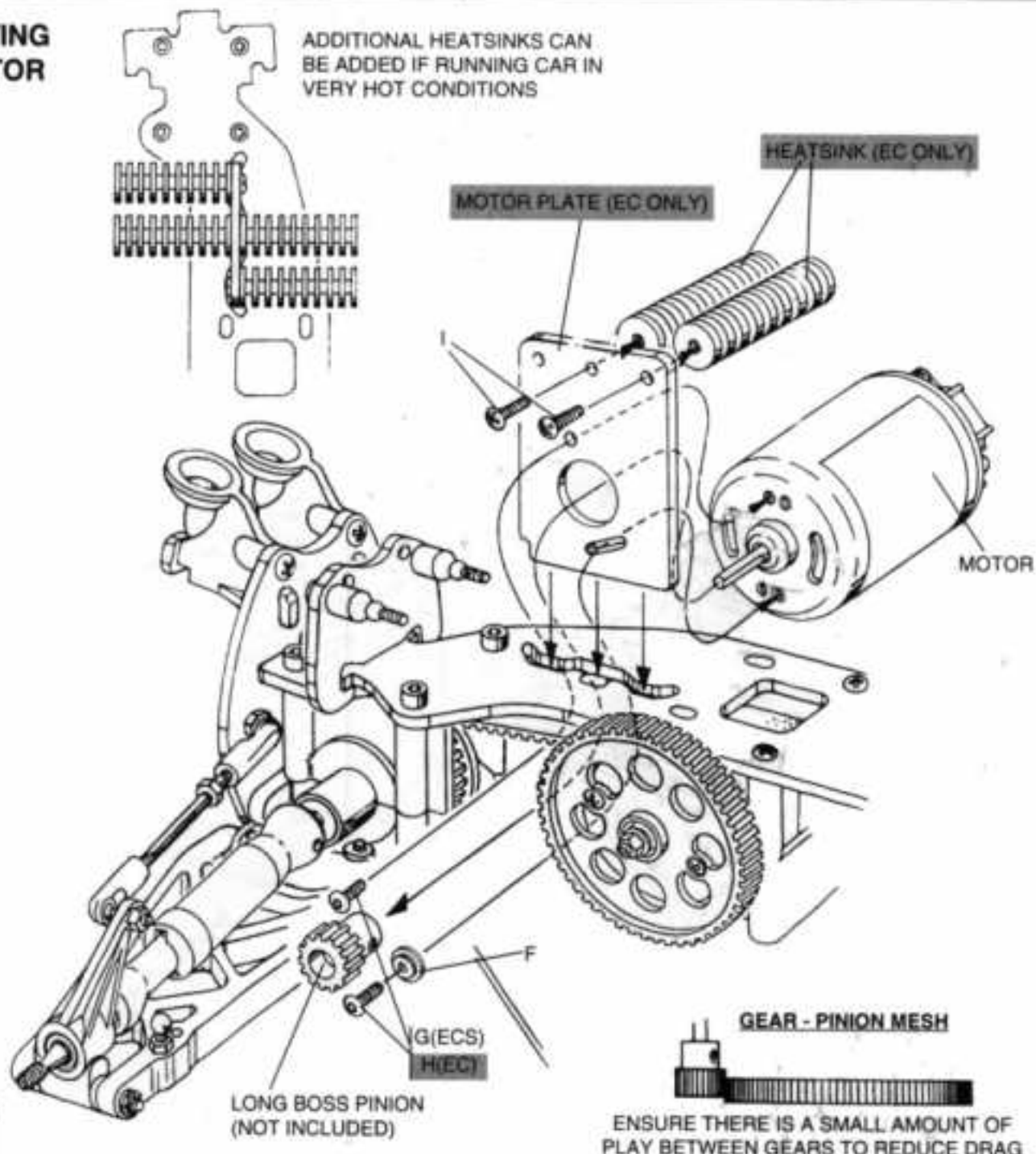

**Schumacher**

**NEW FAT 2000 E.C.**  
THE BEST QUALITY



FITTING ELECTRICS

BAG 7

HARDWARE

- A**  X1  
39mm TURNBUCKLE
- B**  X2  
No4 x 3/8" SELFTAP PANHEAD SCREW
- C**  X2  
1.6mm THICK NYLON WASHER
- D**  X1  
BALL STUD SHORT
- E**  X1  
M3 NYLOC NUT
- F**  X1  
STEPPED WASHER
- G**  X2  
M3 x 8mm BUTTONHEAD SCREW

**EC**

- H**  X2  
M3 x 10mm BUTTONHEAD SCREW
- I**  X2  
M3 x 8mm PANHEAD SCREW

**SERVICING****REMOVING FRONT  
SUSPENSION**

REMOVE THE 5  
SCREWS SHOWN AND  
1 NYLOC NUT.  
SLIDE THE SHOCK  
BRACKET OFF AND  
THE ENTIRE FRONT  
SUSPENSION  
ASSEMBLY CAN NOW  
BE REMOVED

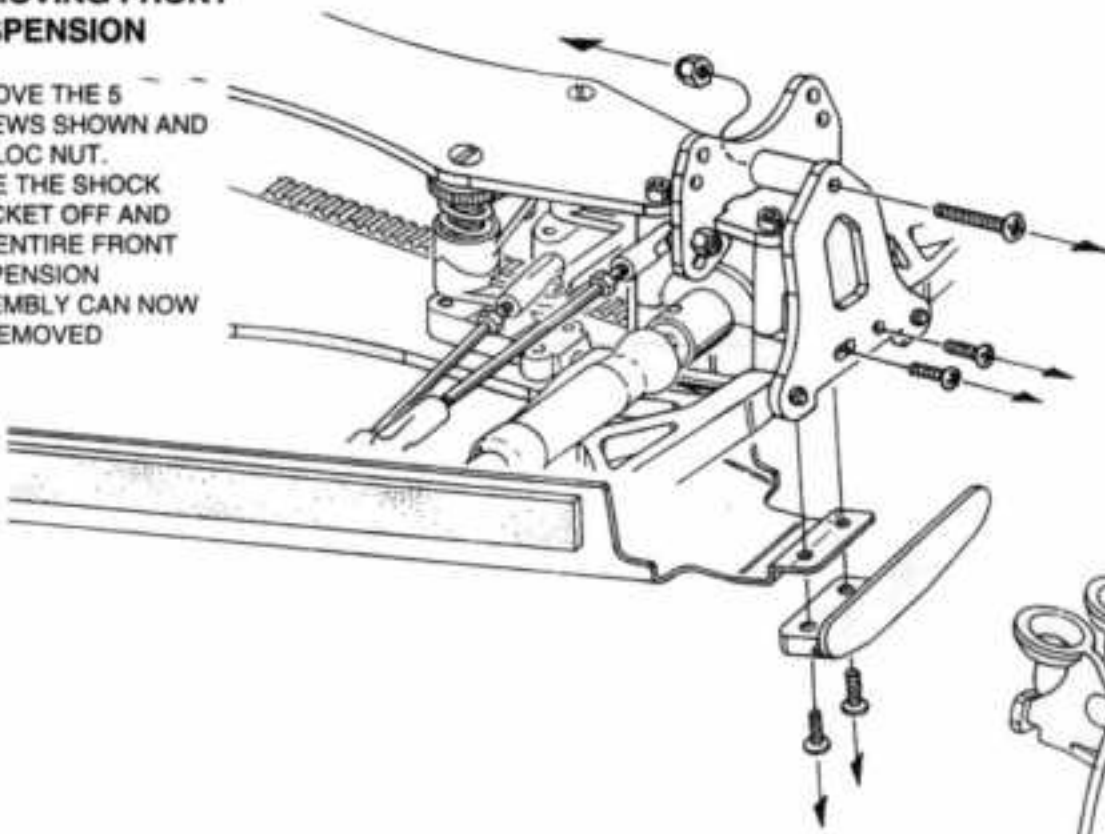
**REMOVING REAR  
SUSPENSION**

REMOVE THE FRONT "E" CLIP  
AND SLIDE OUT PIVOT PIN.  
THE REAR WISHBONE WILL NOW  
BE FREE, RETAINED ONLY BY  
THE BALL GRIPPA

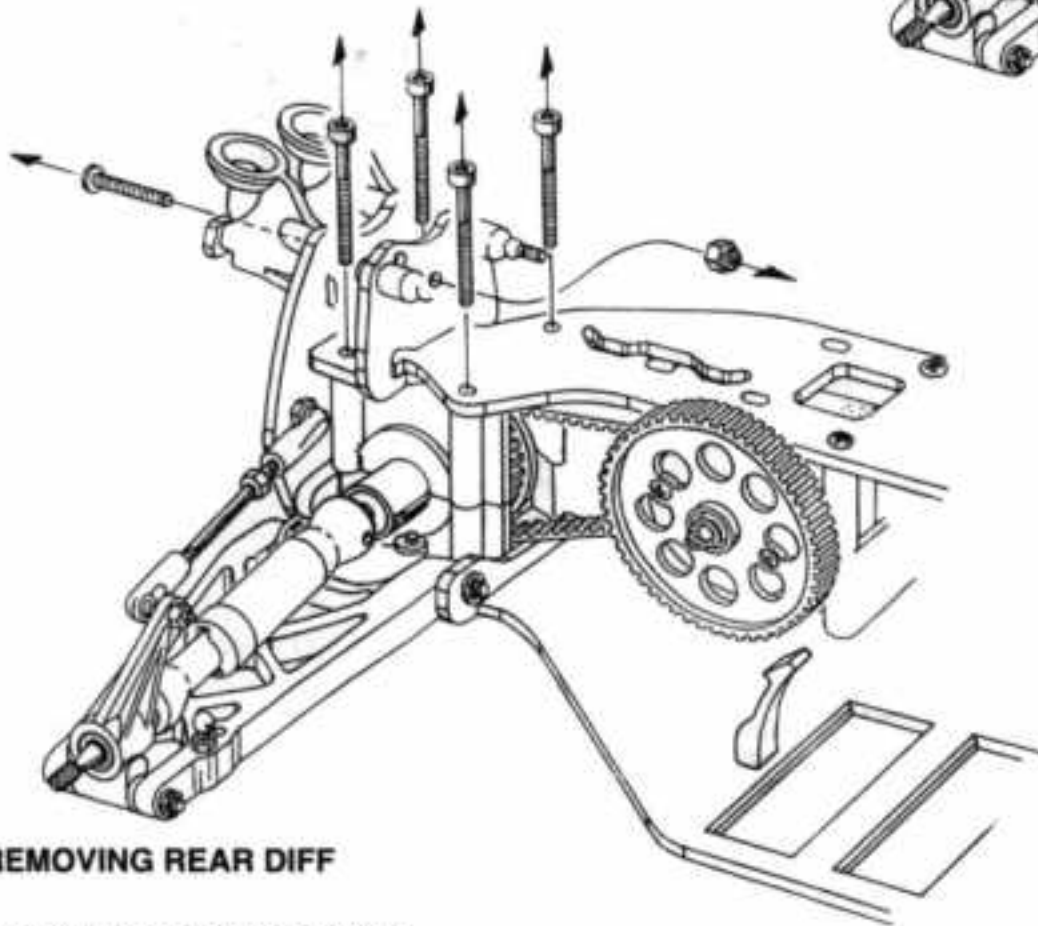
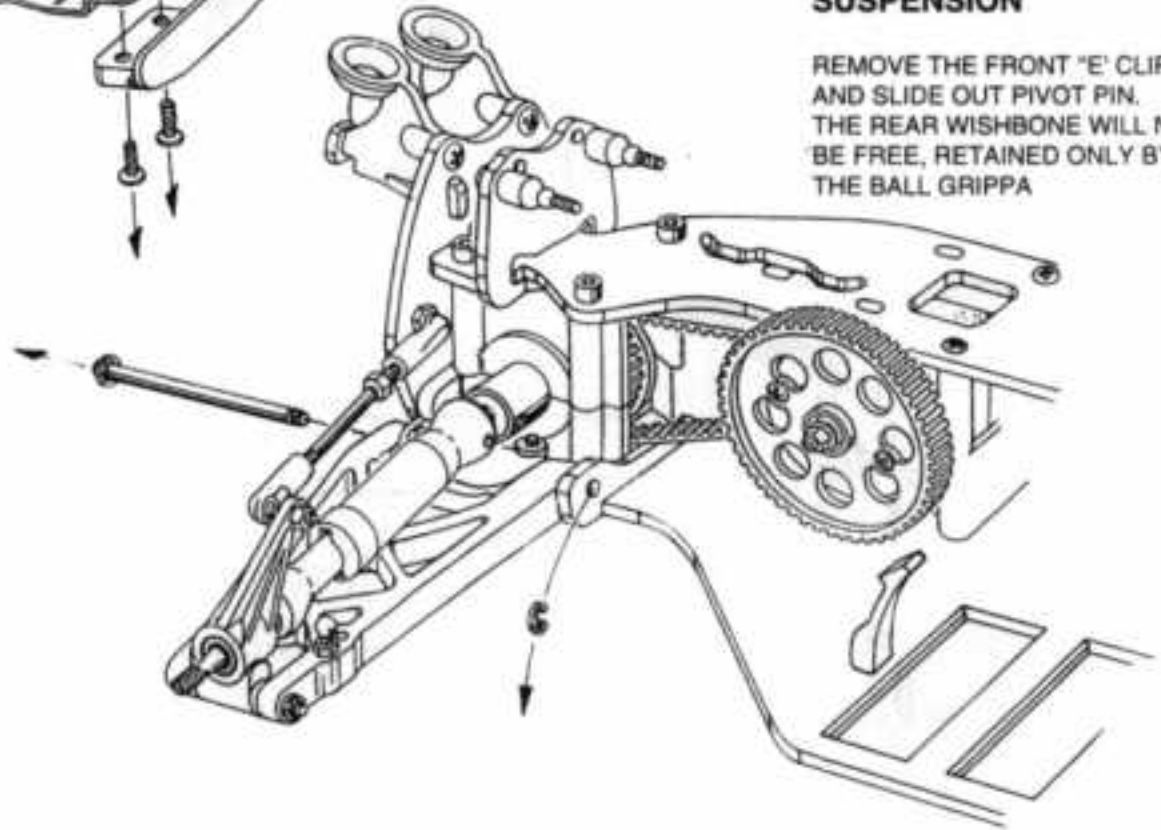
**REMOVING FRONT DIFF**

REMOVE THE 4 CAPHEAD SCREWS AND  
THE 1 PANHEAD SCREW & NYLOC NUT AS  
SHOWN.  
MOVE THE FRONT SHOCK BRACKET  
FORWARDS.  
FLEX TOP CHASSIS UPWARDS.  
FRONT DIFF & DRIVESHAFTS CAN NOW BE  
REMOVED.

**REMOVING REAR DIFF**

REMOVE MOTOR & MOTOR PLATE.  
REMOVE THE 4 CAPHEAD SCREWS, THE 1 PANHEAD  
SCREW & NYLOC NUT SHOWN AND LOOSEN THE 2  
SELFTAP SCREWS THAT HOLD THE BOTTOM OF THE  
WING MOUNT BRACKET TO THE TRANSMISSION  
HOUSING.  
MOVE THE WING MOUNT BRACKET BACKWARDS.  
FLEX TOP CHASSIS UPWARDS.  
REAR DIFF AND DRIVESHAFTS CAN NOW BE REMOVED.

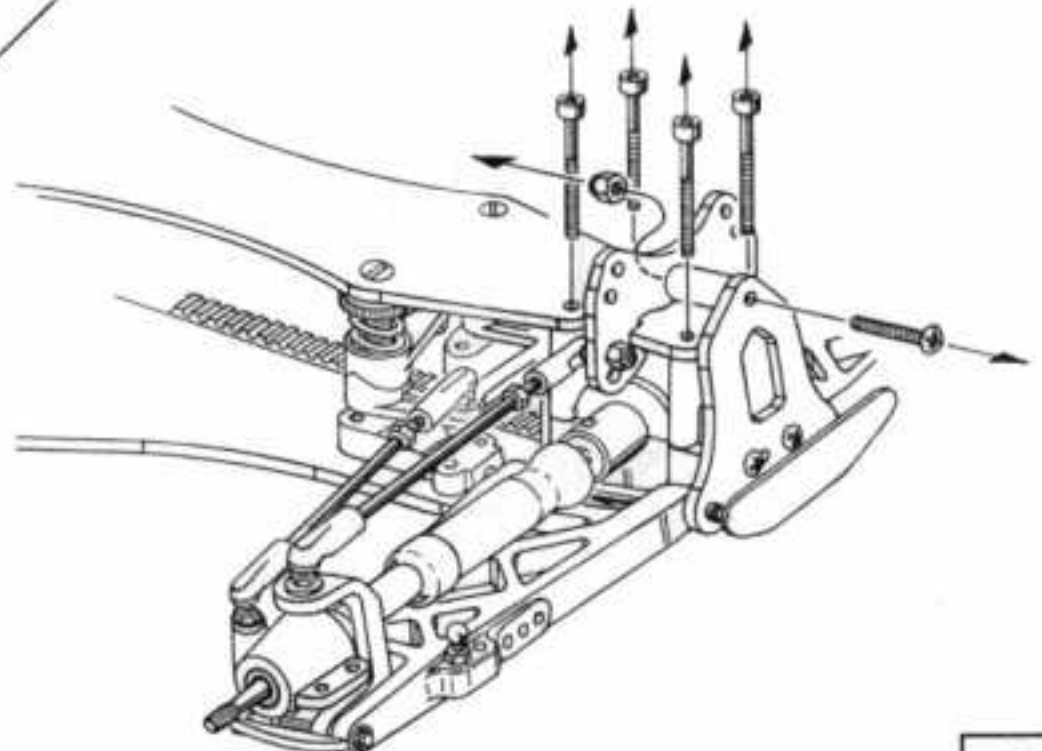

THE FOLLOWING STEPS SHOW THE CORRECT METHOD FOR BUILDING & SETTING UP YOUR DIFFS

**DIFF SERVICING**

**HARDWARE**

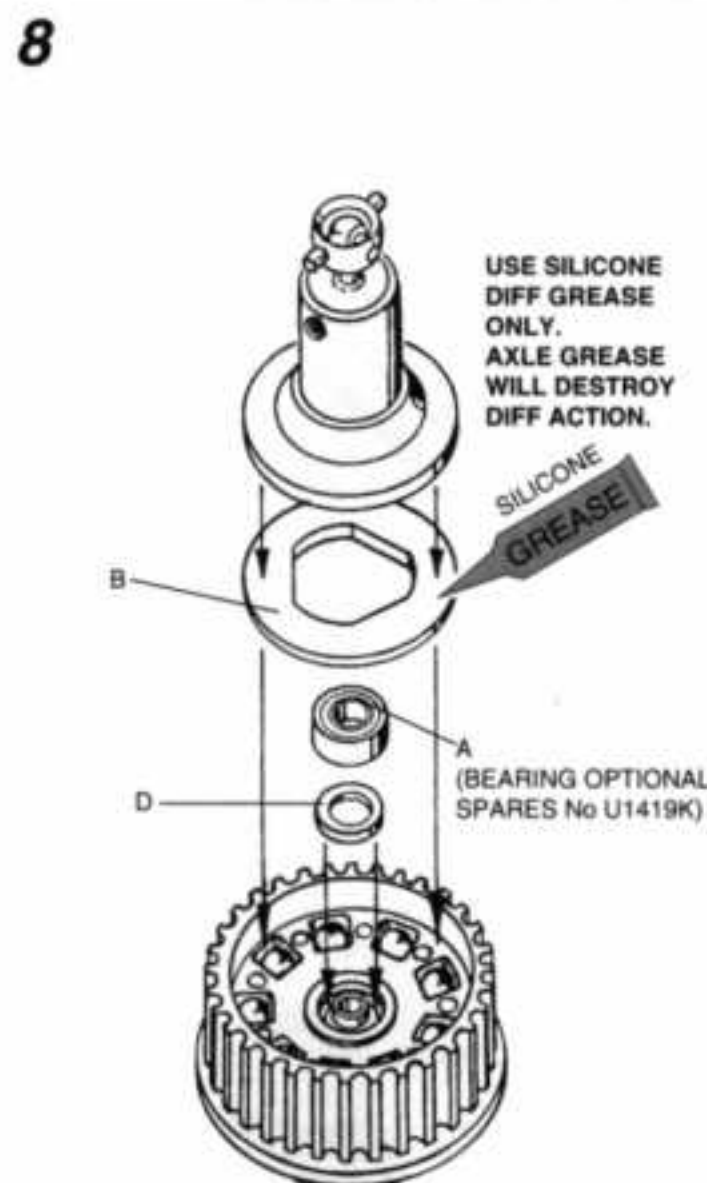
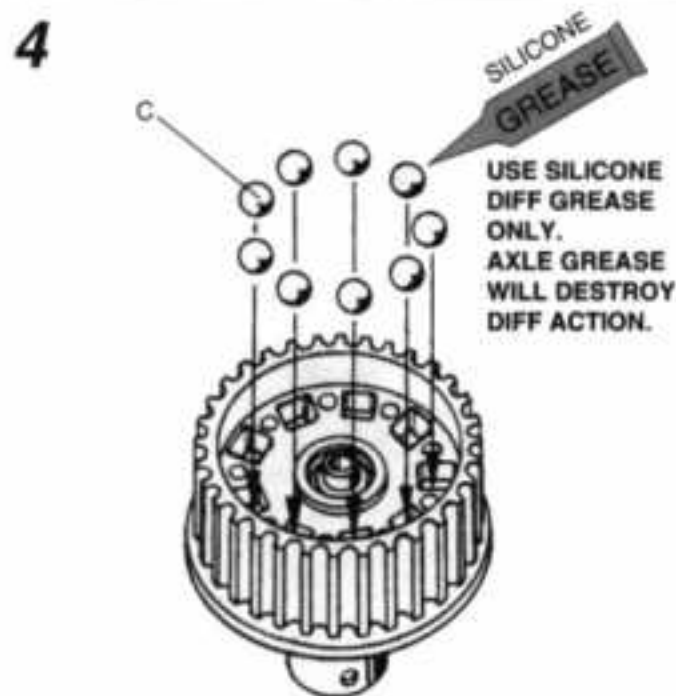
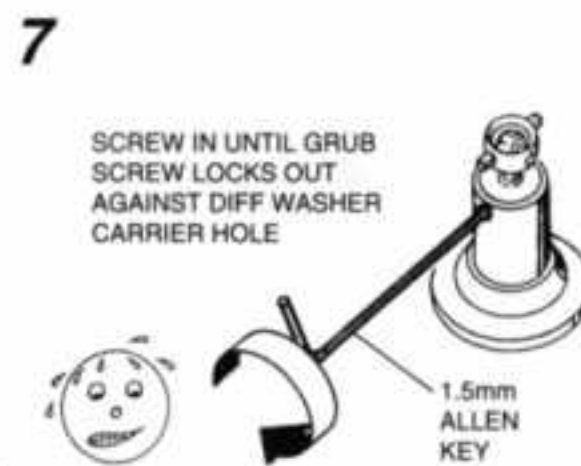
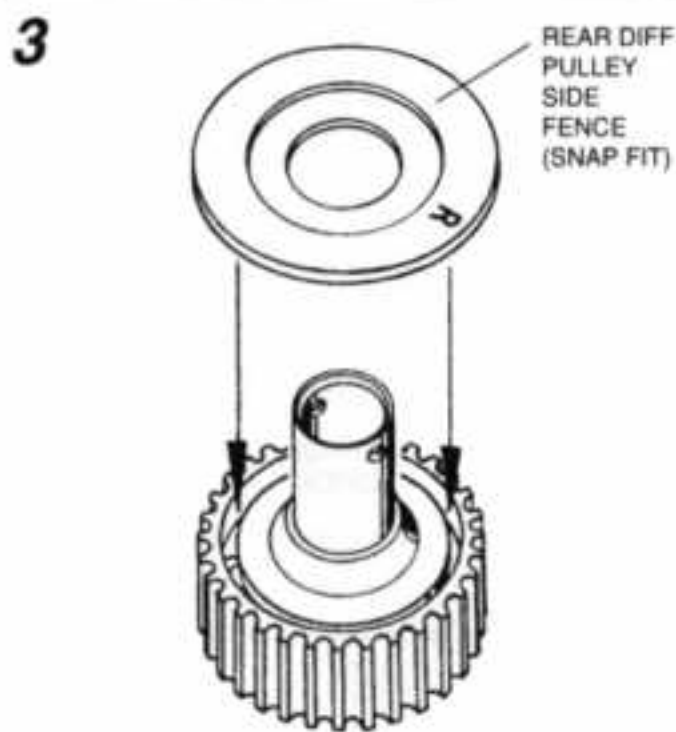
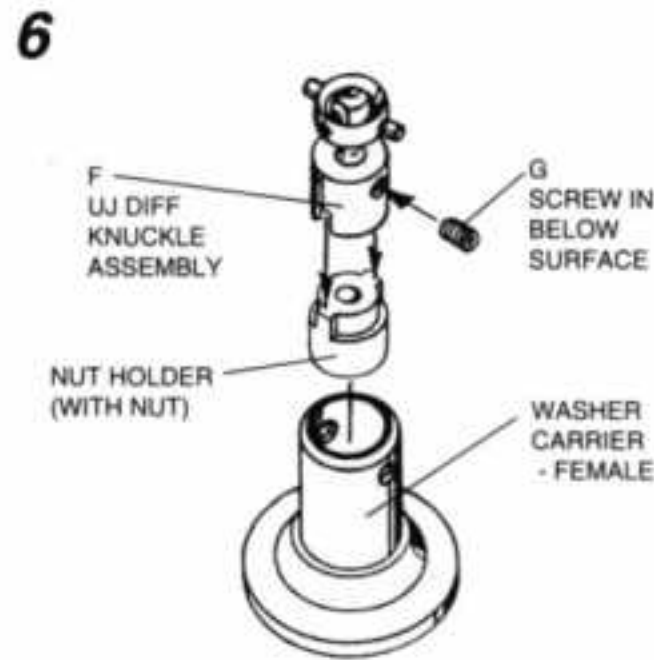
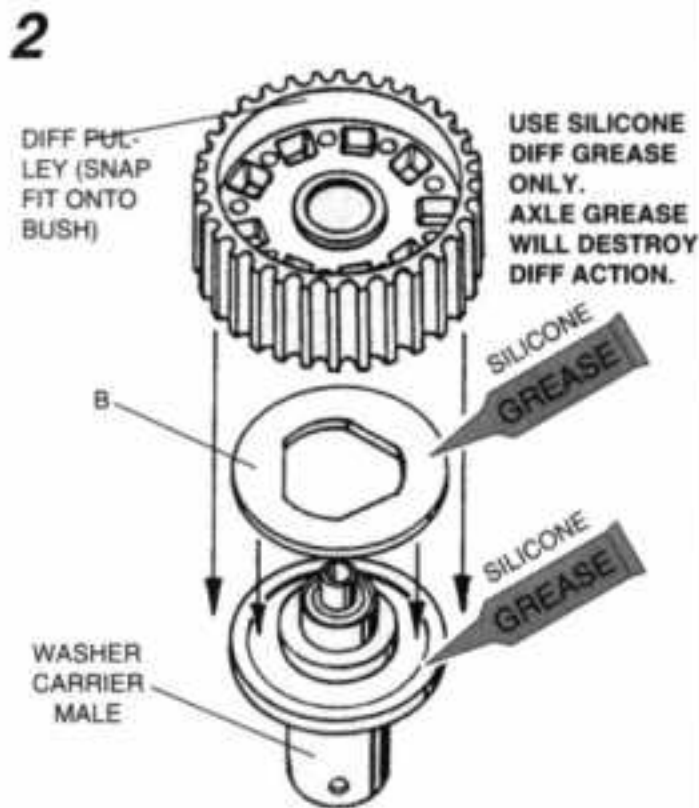
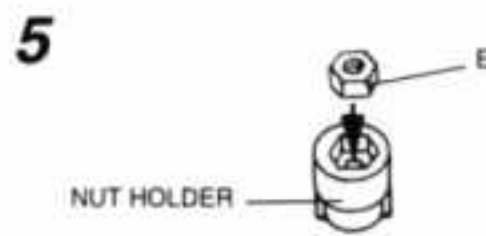
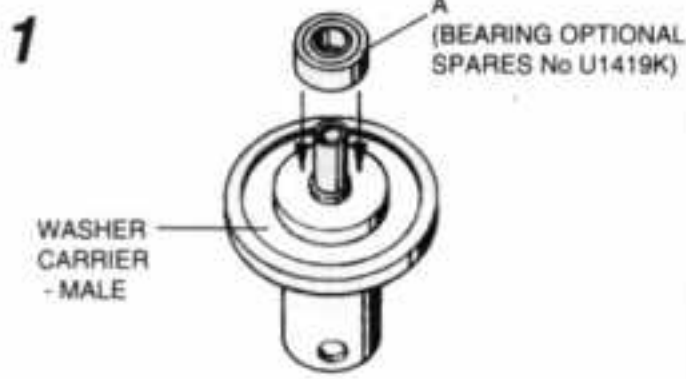

- A X4  
4x8x2mm BUSH
- B X4  
TRILOBE DIFF WASHER
- C X18  
4mm DIA DIFF BALL
- D X2  
DIFF SPACER
- E X1  
M3 NUT
- F X4  
UJ KNUCKLE ASSEMBLY

9

REAR DIFF PULLEY SIDE FENCE (SNAP FIT)

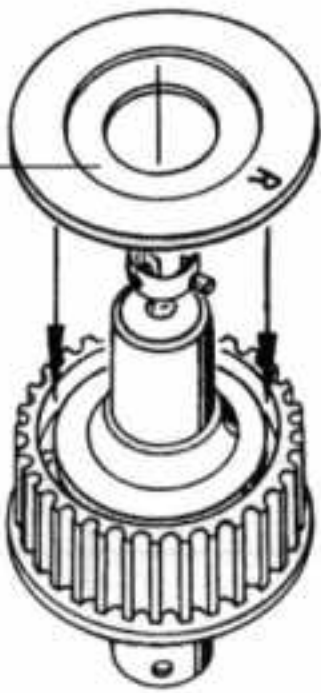

10



NOTE CORRECT WAY TO ASSEMBLE DISC SPRINGS

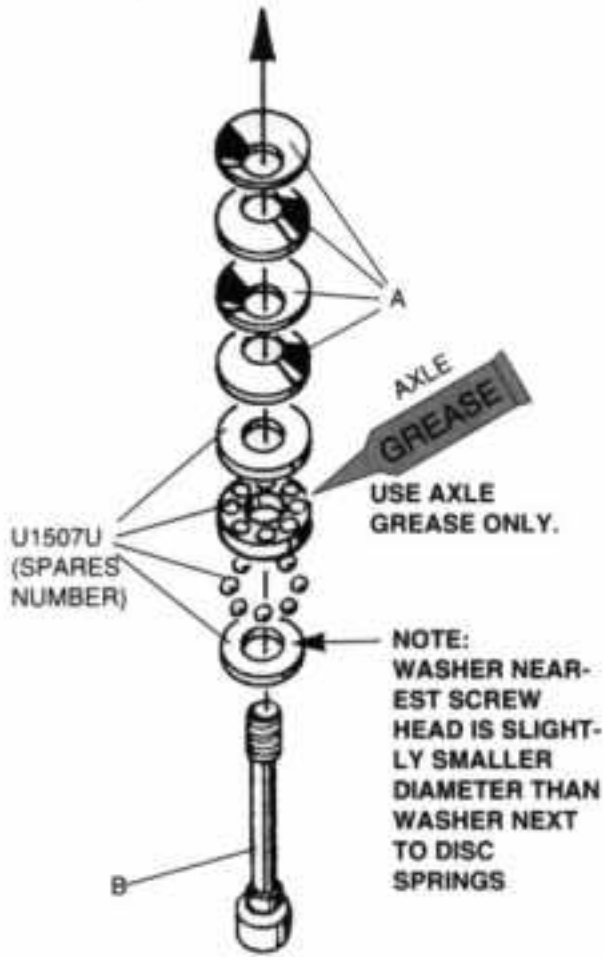

12

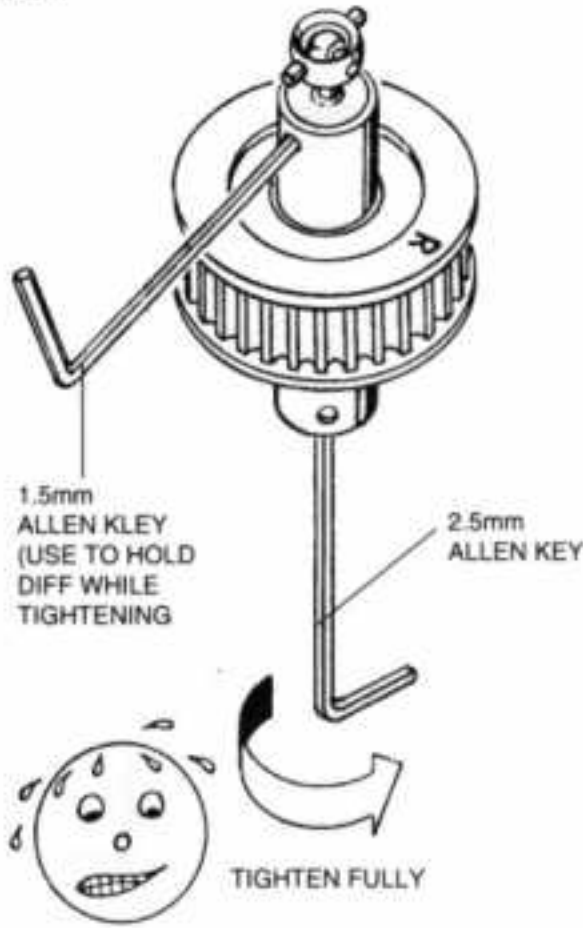

1.5mm ALLEN KEY (USE TO HOLD DIFF WHILE TIGHTENING)

2.5mm ALLEN KEY

TIGHTEN FULLY

13

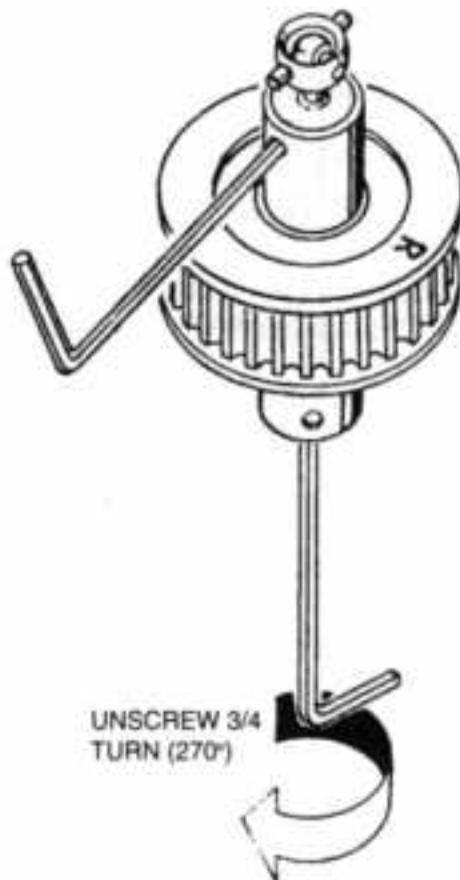

UNSCREW 3/4 TURN (270°)

11

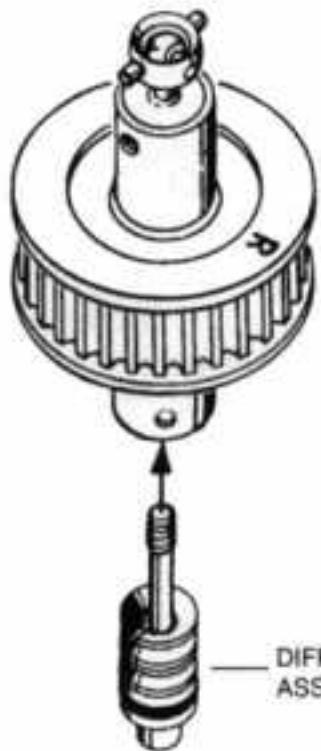

DIFF SCREW ASSEMBLY

14

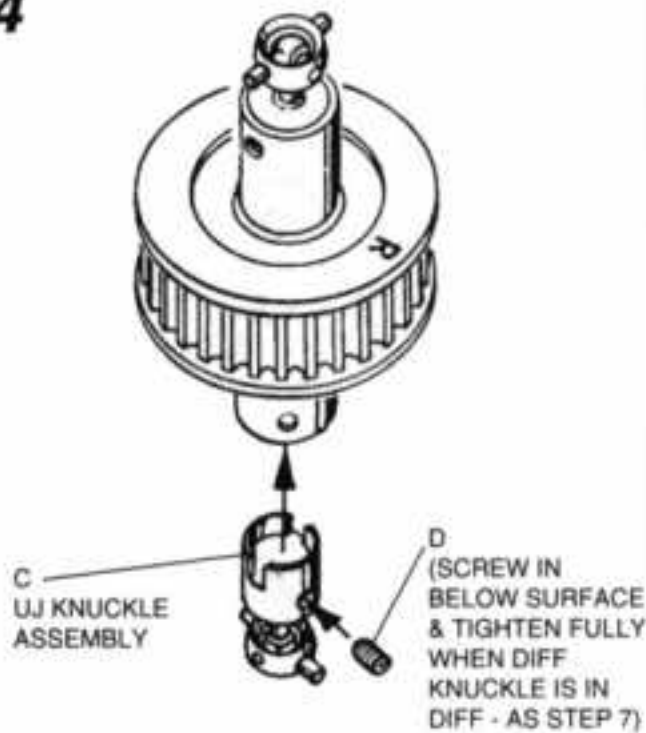

C UJ KNUCKLE ASSEMBLY

D (SCREW IN BELOW SURFACE & TIGHTEN FULLY WHEN DIFF KNUCKLE IS IN DIFF - AS STEP 7)

Schumacher

NEW FAT 2000 E.C. THE BEST MANUFACTURE

DIFF SERVICING

HARDWARE

A X8 DISC SPRING

B X2 DIFF SCREW

C X2 UJ KNUCKLE ASSEMBLY

D X2 M3 x 6mm GRUB SCREW

ASSEMBLY OF FRONT DIFF IS THE SAME BUT USES FRONT DIFF PULLEY FENCES (MARKED 'F')

The table below shows set ups for certain types of track.

Use these as starting points.

Pages 22, 23, 24 and 25 explain in detail how each adjustment affects the cars handling. Use these steps for fine tuning.

On the back cover is a set up sheet which can be photocopied and used to build up a reference record of track conditions and track settings.

**TRACK SETTINGS**

ADJUSTMENT	GRASS TRACK GOOD GRIP	CLAY-DIRT TRACK SLIPPERY	CARPET RACING				
<b>FRONT SUSPENSION</b>							
FRONT CAMBER	0°	-1°	-1°				
FRONT CASTOR	0°	+5°	+5°				
BUMP STEER SPACER	1.6mm	8mm	8mm				
FRONT TOE-IN	STRAIGHT	STRAIGHT	STRAIGHT				
FRONT RAKE ANGLE	12°	12°	12°				
TOP LINK POSITION	A	A	B				
<b>SHOCK ABSORBERS - FRONT</b>							
SPRINGS	YELLOW	YELLOW	GREY				
OIL	30W	30W	40W				
SHOCK POSITION - WISHBONE	OUTER (No2)	OUTER (No2)	OUTER (No2)				
SHOCK POSITION - TOP	2	1	1				
HOLES OPEN IN PISTON	4	4	4				
SPACERS	8mm	10mm	8mm				
<b>REAR SUSPENSION</b>							
REAR CAMBER	-1°	-1°	-1°				
REAR TOE-IN	2°	3°	2°				
TOP LINK POSITION	A	A	A				
WHEELBASE	MED	SHORT	MED				
<b>SHOCK ABSORBERS - REAR</b>							
SPRINGS	YELLOW	WHITE	YELLOW				
OIL	30W	30W	40W				
SHOCK POSITION - WISHBONE	INNER (No1)	OUTER (No2)	OUTER (No2)				
SHOCK POSITION - TOP	2	2	2				
HOLES OPEN IN PISTON	4	4	4				
SPACERS	12mm	20mm	8mm				
<b>TRANSMISSION</b>							
SLIPPER CLUTCH (SLIP DIST)	0.50 metres	0.75 metres	0.25 metres				
PINION	20 T	20 T					
SPUR GEAR	95 T	92 T					
MOTOR TURN	12 x 2	12 x 2					
HEAT SINKS							
BODYSHELL CUTOUTS							
<b>TYRES</b>							
FRONT							
REAR							
<b>OPTIONAL EXTRAS</b>							
REAR ANTI-ROLL BAR							
FRONT ANTI-ROLL BAR							

TYRES: F = FOAM INSERT

**FRONT SHOCK BRACKET**

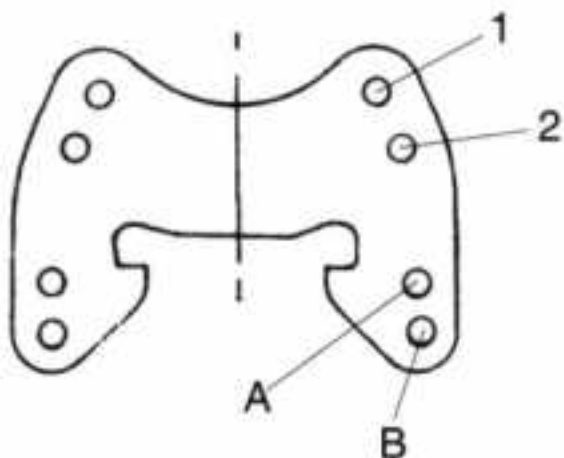

**REAR TOP LINK BRACKET**

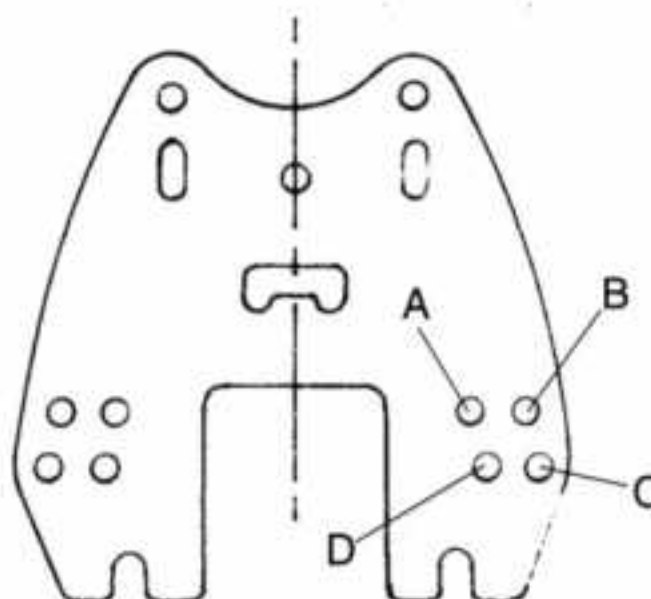

**REAR SHOCK BRACKET**

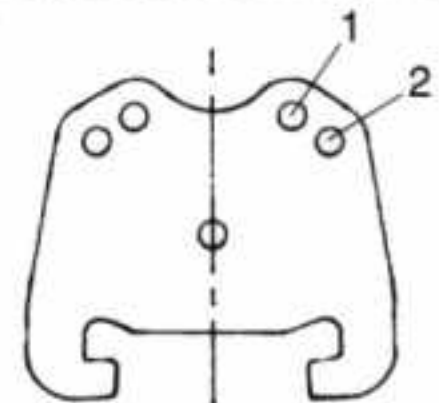

**1** Make sure screws are tight, recheck after each race.

**2 WHEELBASE**  
The cars wheelbase can be altered by moving the washers that sit between the rear hub carrier and the wishbone.  
There are 3 possible settings.  
Generally the shorter wheelbase gives more rear traction, a longer wheelbase improves steering response.

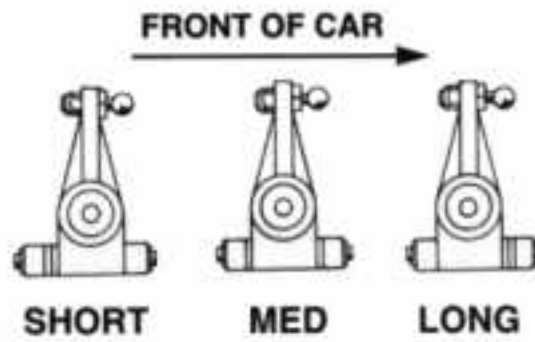

**3 DIFF**  
If the transmission is correctly built you should hear a clicking sound when you spin the front wheels. If you don't, check layshaft assembly for free movement of oneway dog. If the differentials are correctly built as in the transmission steps they should not need adjusting during racing. Any slip adjustment should be done on the slipper clutch.  
**DO NOT LOOSEN THE THE DIFF TO ACHIEVE SLIP.**  
During maintenance when cleaning diffs be careful to reassemble the correct way.  
If diff does become loose (noticeable by a 'squark' coming from the car when accelerating from standstill) tighten by following steps in Transmission section.

**4 REAR CAMBER**  
The rear wheels should be set at negative camber. This means that the top of the wheels lean inward. Adjustment is carried out by turning the top link. The righthand thread of the link is nearest the hex. Adjust to be the same both sides.  
Too much negative camber and you will have begin to have less traction.

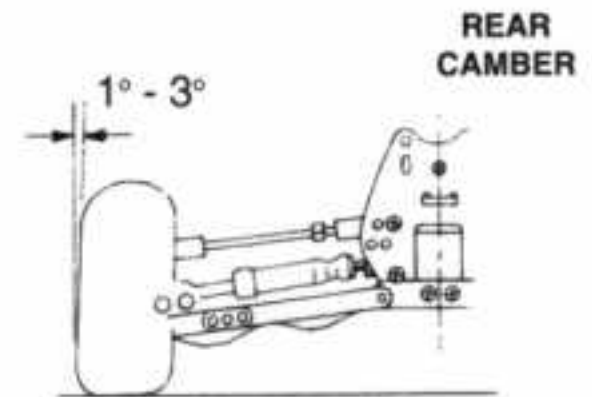

**5 FRONT CAMBER**  
The front wheels should be set at negative camber. Adjust to be the same both sides. Generally the more negative camber, the more steering you will get at high and medium speeds. Too much negative camber and you will begin to have less steering.

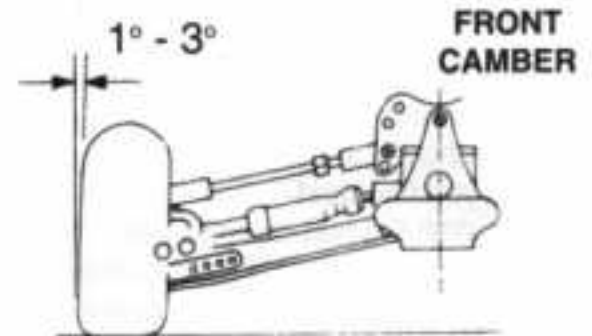

**6 FRONT TOE IN**  
The front track rods are adjustable, similar to the suspension top links. Set the front wheels to be parallel to each other when pointing straight ahead. If conditions are slippery add 1 - 2 deg toe-in, this will make the car steer a little less. Toe-out will give more steering at low speed, but may make the car more unstable on corner exit.

A greater than B = toe-out  
A less than B = toe-in  
A equal to B = parallel (standard setting)

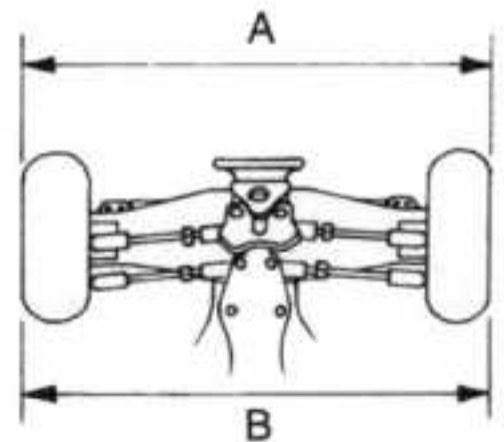

**7 REAR TOE IN**  
The rear hub carriers in the kit give 3° toe-in. Others are available as spares in 0°, 1°, 2°, & 4°. More rear toe in will give more power understeer and more stability and traction at the rear, recommended for tracks with low traction.

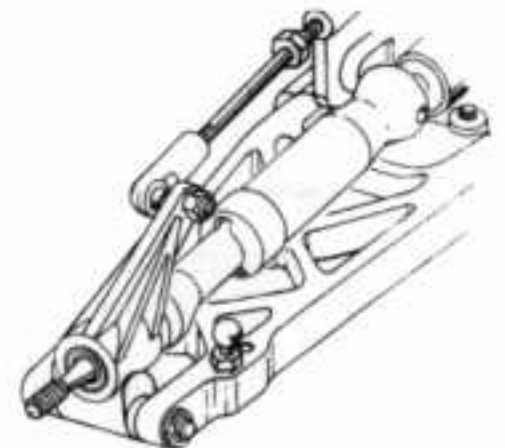

**8 ROLL CENTRE**  
Altering the rear top link position changes the roll centre.

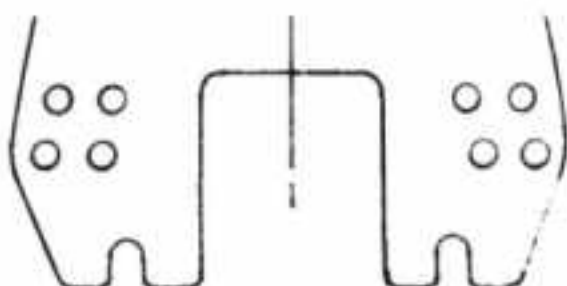

## 9 SUSPENSION TUNING

Use the set up sheets on page 22 as a starting point.  
If your CAT 2000 EC requires further fine tuning these notes will give you additional information

### RIDE HEIGHT

Fit spring spacers to set the required ride height.  
Spring spacers only change ride height, they do not alter suspension stiffness.  
Laid down shocks as on CAT 2000 EC will require more spring spacers than upright shock cars.

### SPRING RATES

The spring rate controls suspension stiffness as follows:

SUSPENSION STIFFNESS	SPRING COLOUR	SPRING RATE
VERY HARD	BLACK	6
HARD	BLUE	4
MEDIUM	GREY	3
SOFT	YELLOW	2
VERY SOFT	WHITE	1.5

NOTE: SPRINGS ARE AVAILABLE IN THREE LENGTHS: S (Short), M (Medium), L (Long)

### SUSPENSION TRAVEL

'Max Droop' is the 'ground clearance' measured with the suspension fully extended.  
'Ride Height' is the 'ground clearance' when the normally laden car sits on the ground.  
'Max Bump' is when the suspension bottoms out which may occur before the chassis bottoms out giving a small ground clearance, or the chassis may ground out first giving overtravel.  
Choose shock mounting holes on the wishbone and shock brackets primarily to achieve the max droop ground clearance you find best.  
With the laid down shocks of the CAT 2000 EC the shock angle changes are not very significant as far as suspension stiffness is concerned, although the more laid down positions will be slightly softer.  
It may be helpful to put spacers on the shock rods in order to control the maximum bump position.

### DAMPERS

Oil weight and piston holes control the damping effect as shown:

No OF HOLES IN PISTON	RELATIVE DAMPER STIFFNESS			
	OIL WEIGHT			
	10W	20W	30W	40W
1	3.5	5.5	7.7	11.4 (HARD)
2	3.3	5.1	7.0	11
3	2	3.6	5.9	8.2
4	1 (SOFT)	1.4	2.4	3.1

NOTE : AMBIENT TEMPERATURE AFFECTS DAMPER STIFFNESS  
20w oil at 50° F (10° C) is approximately the same as 30w oil at 80° F (27° C)

Always record your suspension settings and results for future reference.

**10 FRONT CASTOR - OPTIONAL EXTRA (SPEED SECRETS)**

The front castor is the angle of the front king pin in relation to a perpendicular line to the ground. There are 4 different options. When running different castor angles and top link positions a washer(s) will need to be added below the steering trackrod ball stud at the wheel to eliminate bump steer. (Bump Steer Kit available - Speed Secrets)



-5° -8° 0° +5° +8°

MORE CASTOR LESS CASTOR

With more castor car is a little more stable coming out of corners and gives more high speed steering. With less castor the car has more low speed steering and sharper 'turn in'.

**11 TYRES**

The front and rear tyres in the kit will give safe predictable handling for most conditions. However, Schumacher CAT range of tyres offer a wide range of options to cover all extremes of operating conditions. The spikes on the tyres may be cut to adjust the handling.

**12 GEAR RATIO CHART - FOR 5 MINUTE RACE USING 1700 mAh NICADS**

PINION	SPUR GEAR	OVERALL RATIO	APPROX MOTOR WIND
28	86	6.14	27 T
28	89	6.36	
27	86	6.37	
27	89	6.59	
26	86	6.62	
26	89	6.85	
25	86	6.88	
25	89	7.12	20 T
25	92	7.36	
24	86	7.17	
24	89	7.42	19 T
24	92	7.67	
23	86	7.48	
23	89	7.74	
23	92	8.00	17 T
22	86	7.82	
22	89	8.09	
22	92	8.36	16 T
22	95	8.63	15 T
21	86	8.19	
21	89	8.48	
21	92	8.76	
21	95	9.05	

MILD MOTOR

PINION	SPUR GEAR	OVERALL RATIO	APPROX MOTOR WIND
20	86	8.60	
20	89	8.90	
20	92	9.20	15 T
20	95	9.50	
19	86	9.05	
19	89	9.37	
19	92	9.68	
19	95	10.00	14 T
18	89	9.89	
18	92	10.22	
18	95	10.55	
17	89	10.47	13 T
17	92	10.82	
17	95	11.18	
16	89	11.13	12 T
16	92	11.50	
16	95	11.86	
15	92	12.27	11 T
15	95	12.67	

HOT MOTOR

**13 LUBRICATION**

All bearings must be lubricated, especially during wet weather. Always remove bearings and clean after running in wet conditions. Plastic parts should NOT be lubricated. Only use silicone grease inside the differential and only use axle grease in the thrust races.

**14 GENERAL**

In general the car should understeer, - this means the front wheels slide more than the rear wheels during cornering. You can get this by cutting the spikes of the front tyres down. It helps to have two or three sets of front tyres with different levels of spikes to test for the best option.

Run the lowest ride height that track conditions allow - a low car always corners better than a high car. Use the softest damper settings that stop the wheels from bouncing. It is easy to over damp the car and cause bouncing at high speed.

DRIVER :  
 TRACK :  
 TRACK CONDITIONS :

MEETING :  
 DATE :

## FRONT SUSPENSION

RAKE	10°	12°	20°				
CASTOR	0°	+5°	-5°	+8°	-8°		
TOE-IN	-1°	-2°	-3°	0°	+1°	+2°	+3°

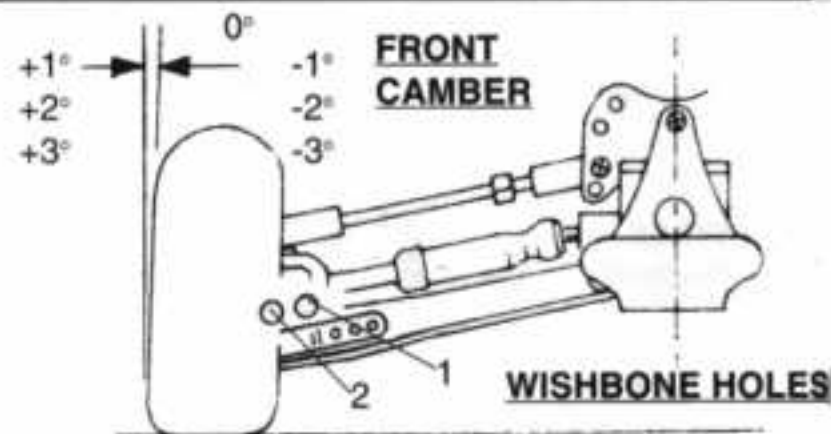

### FRONT SHOCK BRACKET

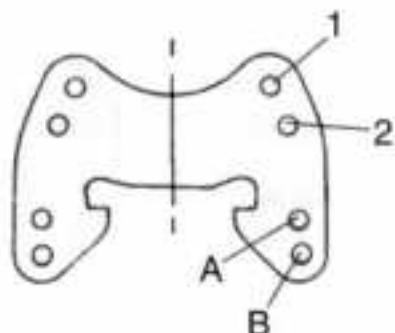

### SHOCKS - FRONT

OIL	10W	20W	25W	30W	35W	40W	45W	50W
HOLES OPEN	1	2	3	4				
VALVED	YES	NO						
SPRINGS	WHITE	YELLOW	GREY	BLUE	BLACK			
SPACERS						mm		

## REAR SUSPENSION

TOE-IN	1°	2°	3°	4°
--------	----	----	----	----

### REAR CAMBER

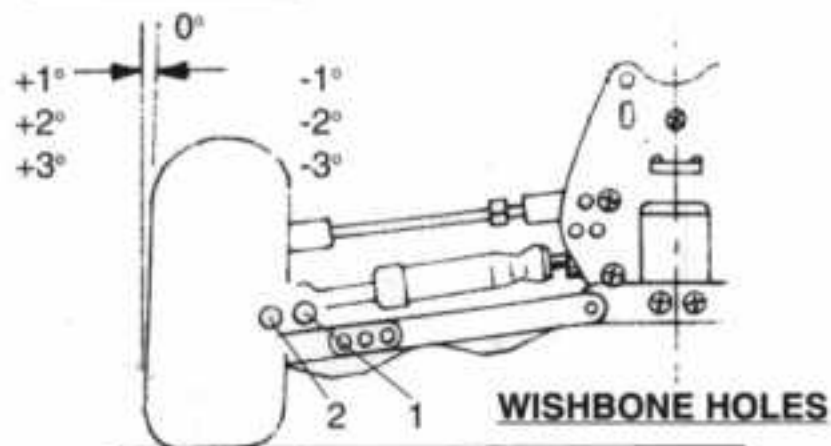

### REAR TOP LINK

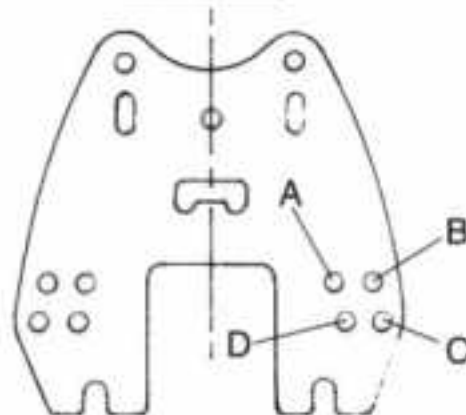

### REAR SHOCK

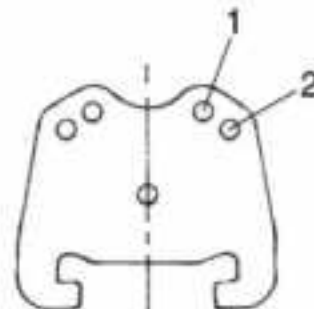

### WHEELBASE



### SHOCKS - REAR

OIL	10W	20W	25W	30W	35W	40W	45W	50W
HOLES OPEN	1	2	3	4				
VALVED	YES	NO						
SPRINGS	WHITE	YELLOW	GREY	BLUE	BLACK			
SPACERS						mm		

## TRANSMISSION & CHASSIS

SPUR GEAR	86T	89T	92T	95T	98T			
PINION	15T	16T	17T	18T	19T	20T	21T	22T
HEATSINKS	1	2	3	4	5	OTHERS		
SLIPPER (SLIP DIST)	0.25m		0.50m		0.75m			
DRIVESHAFTS	ROLLER		PLAIN					

CELLS - TYPE .....  
 MOTOR TYPE / WIND .....  
 RECEIVER .....

SERVO .....  
 SPEED CONTROLLER .....

### TYRES

FRONT U.....  
 REAR U.....

FOAMS - YES/NO  
 FOAMS - YES/NO

FRONT HEX DRIVES - WIDE NARROW  
 REAR HEX DRIVES - WIDE NARROW

BODYSHELL CUT OUTS SIDE DUCT OTHERS WING TYPE .....

# NEW CAT 200 EC

1142 ALU-GLASS-STEEL

## SPARES DIAGRAM

ALTERNATIVES MAY BE FOUND IN THE SPARES LISTS

- U5055F BODY/SHELL "LAYDOWN" - CAT 2000 EC
- U5037N UNDERTRAY - CAT 2000
- U1515C DECAL SHEET - CAT 2000
- U1802E INSTRUCTION MANUAL - CAT 2000
- U1808K SPEED MOUNT W/F - CAT 2000 EC

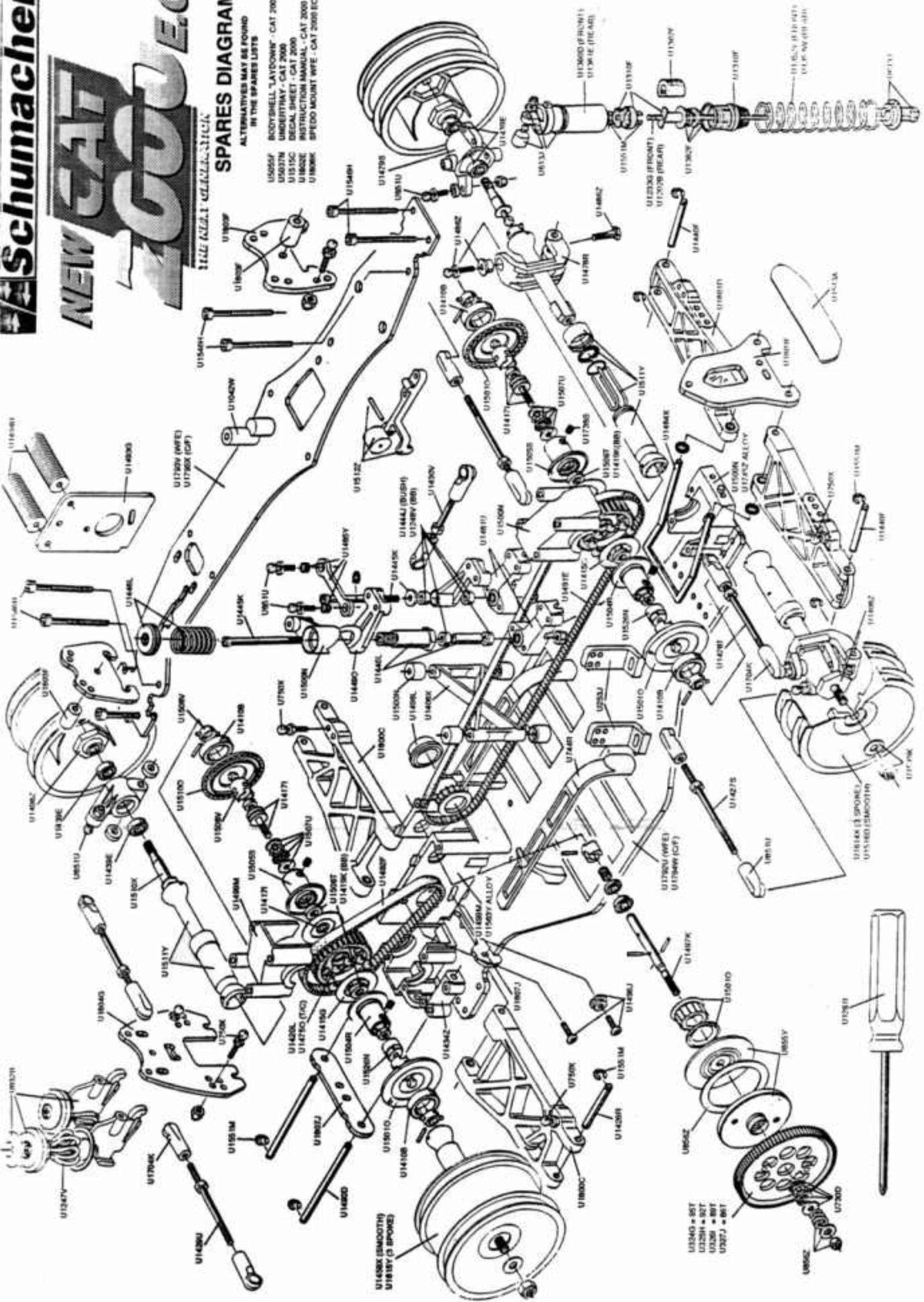

- U1240 - 8T
- U1250 - 8T
- U1260 - 8T
- U1270 - 8T





**Schumacher**  
**REAR ANTI ROLL BAR**

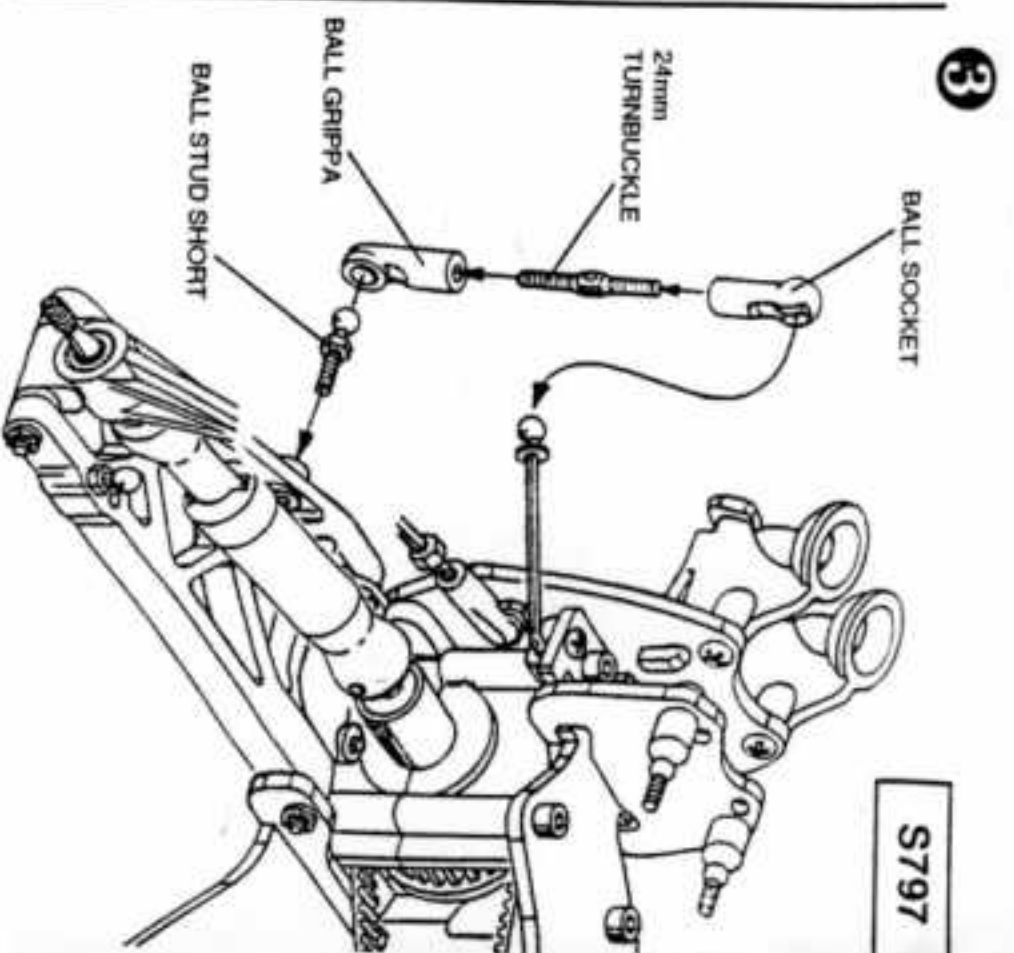
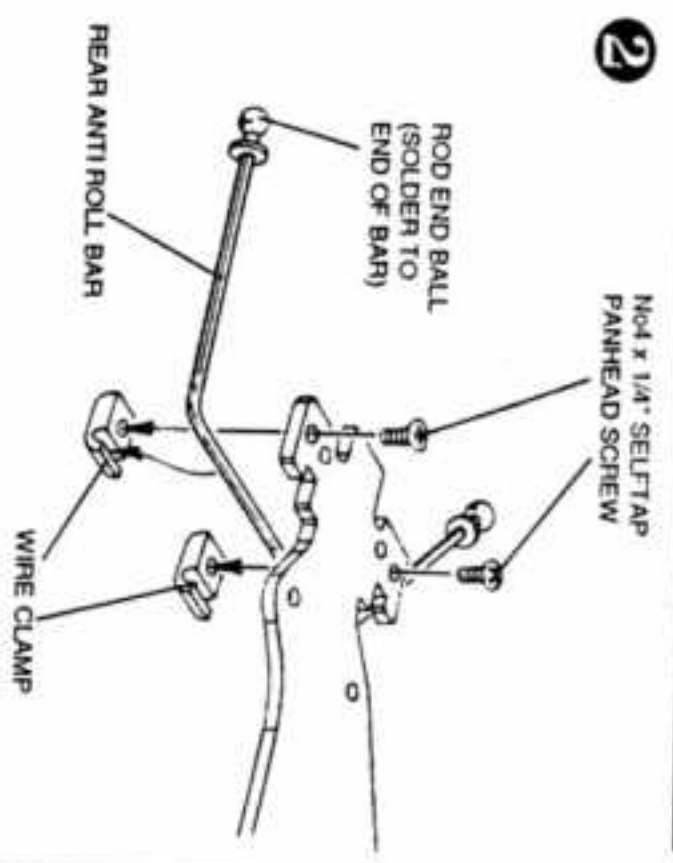
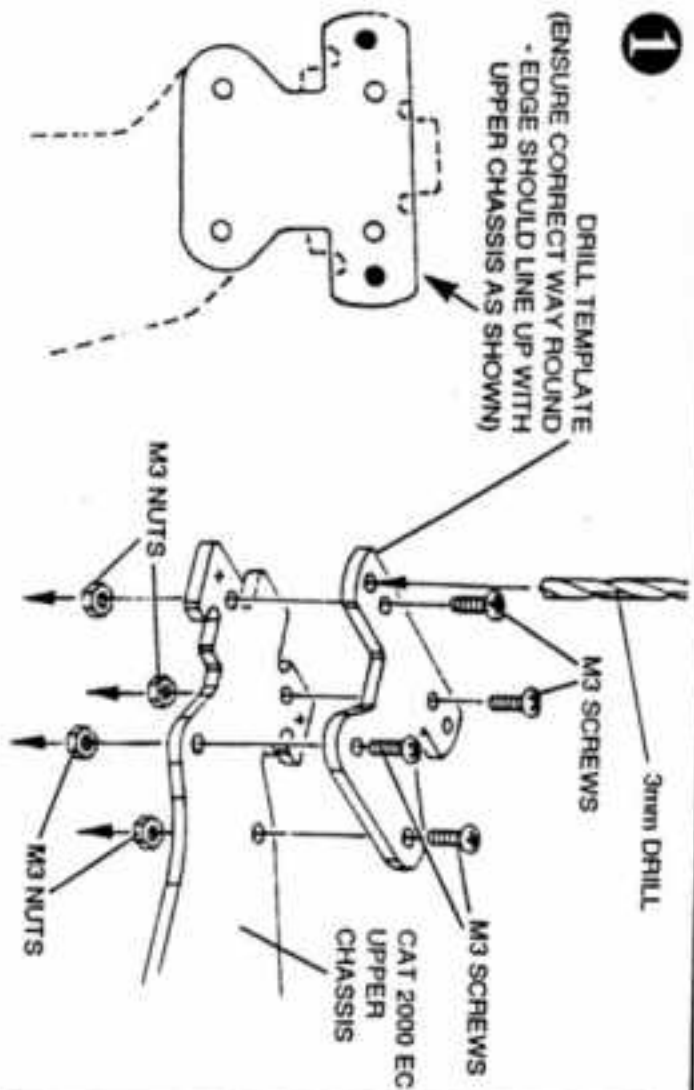

**Schumacher**  
**REAR ANTI ROLL BAR**

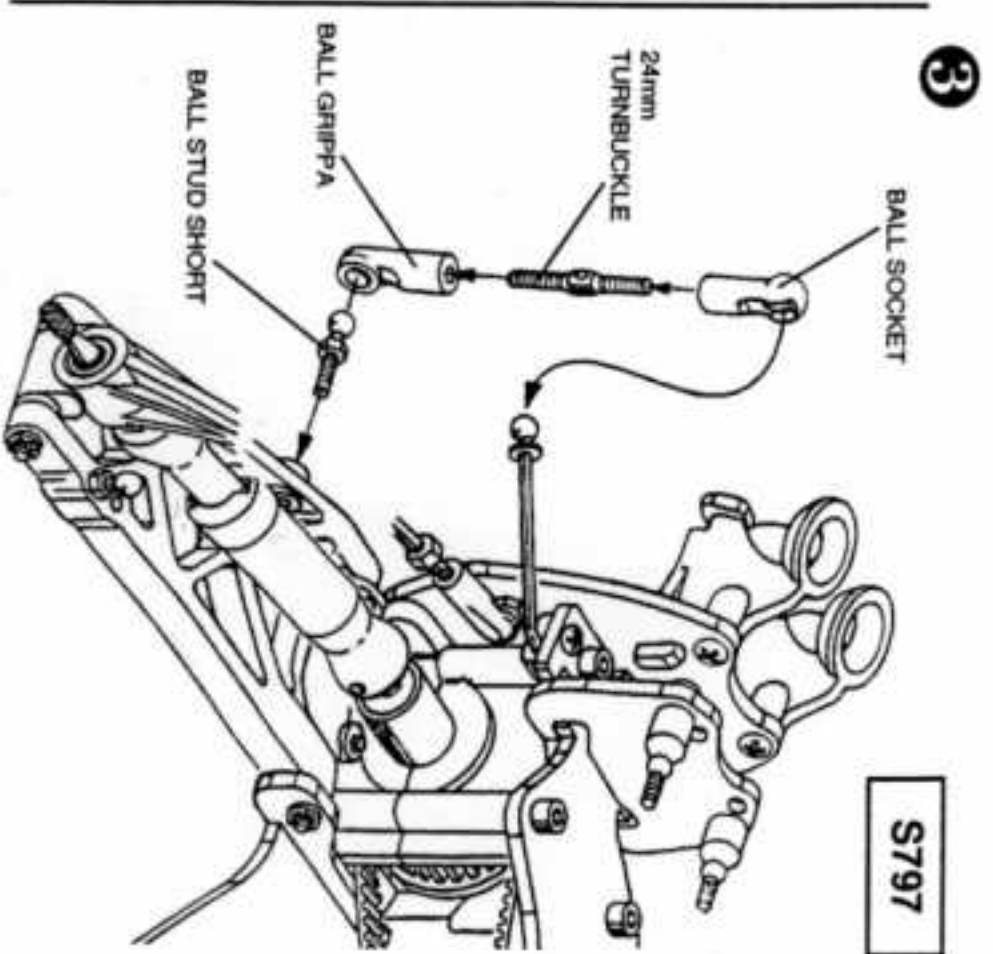
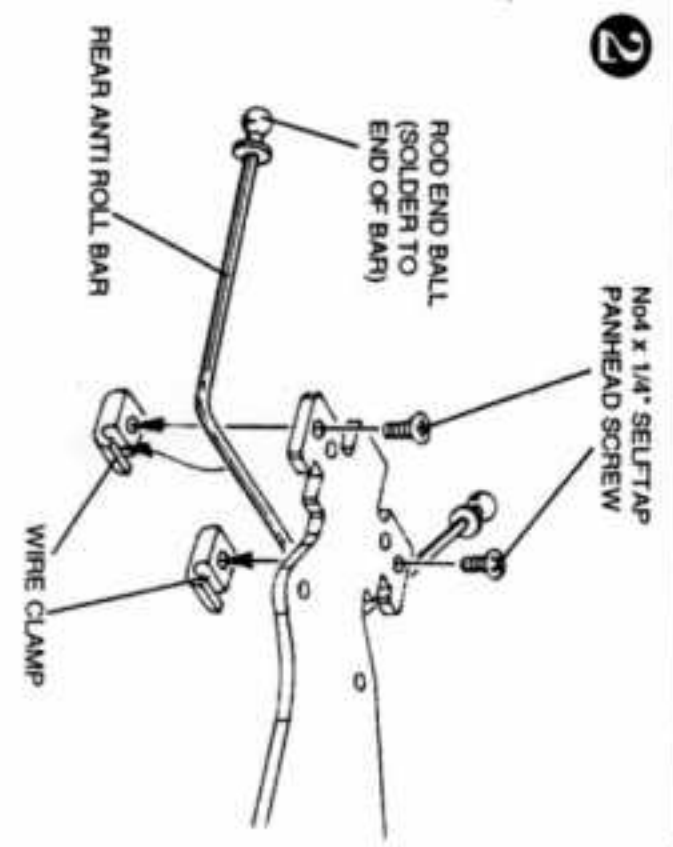
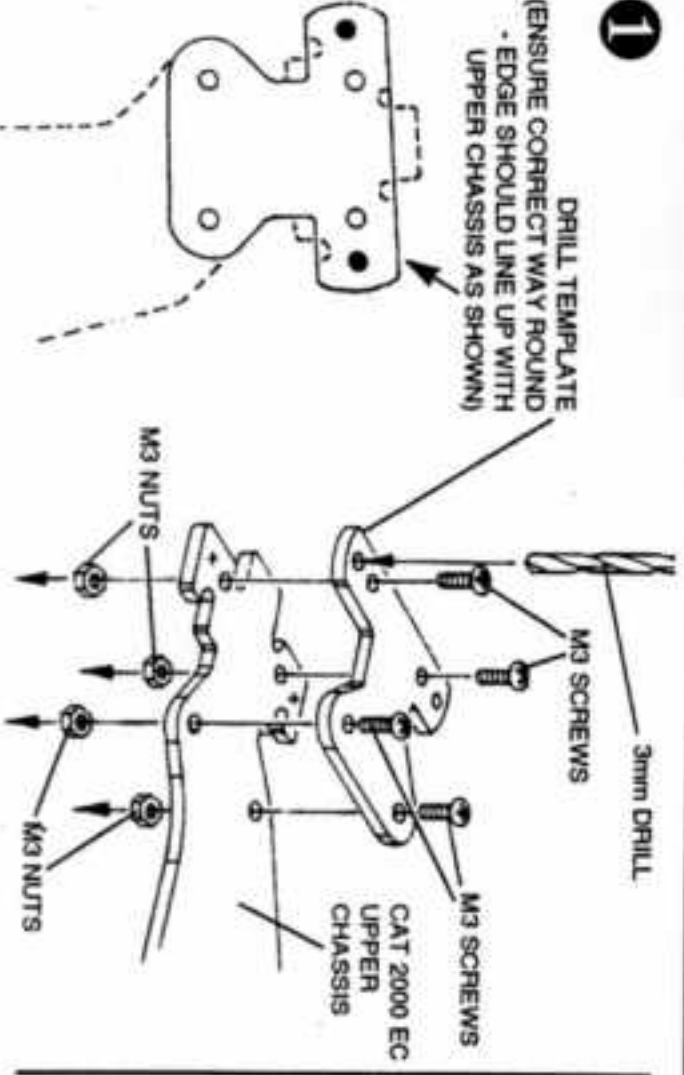

## ALUMINIUM ONEWAY ROLLER CLUTCH LAYSHAFT PULLEY



**1** CAREFULLY PRESS THE BRASS BUSHES & ONEWAY ROLLER CLUTCH INTO THE LAYSHAFT PULLEY USING A SMALL VICE

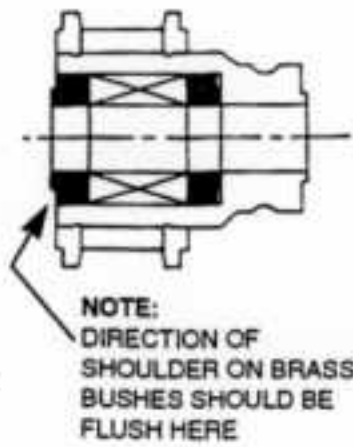
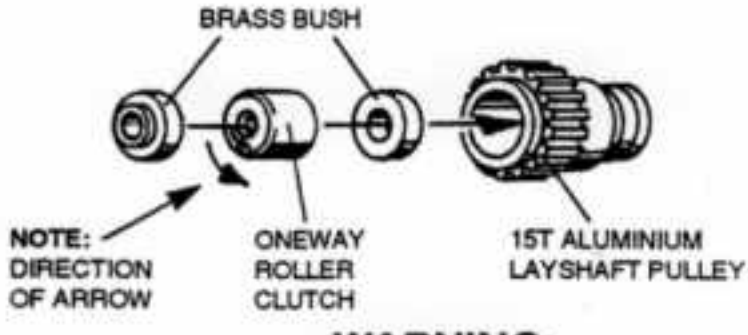

**WARNING:**

MAKE SURE THE ONEWAY ROLLER CLUTCH IS FITTED THE CORRECT WAY ROUND - ONCE ITS IN YOU WON'T BE ABLE TO GET IT OUT

**2**

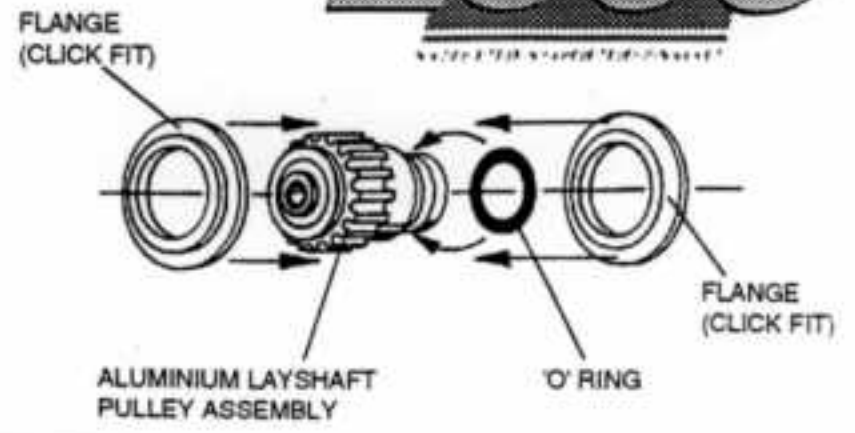

**3**

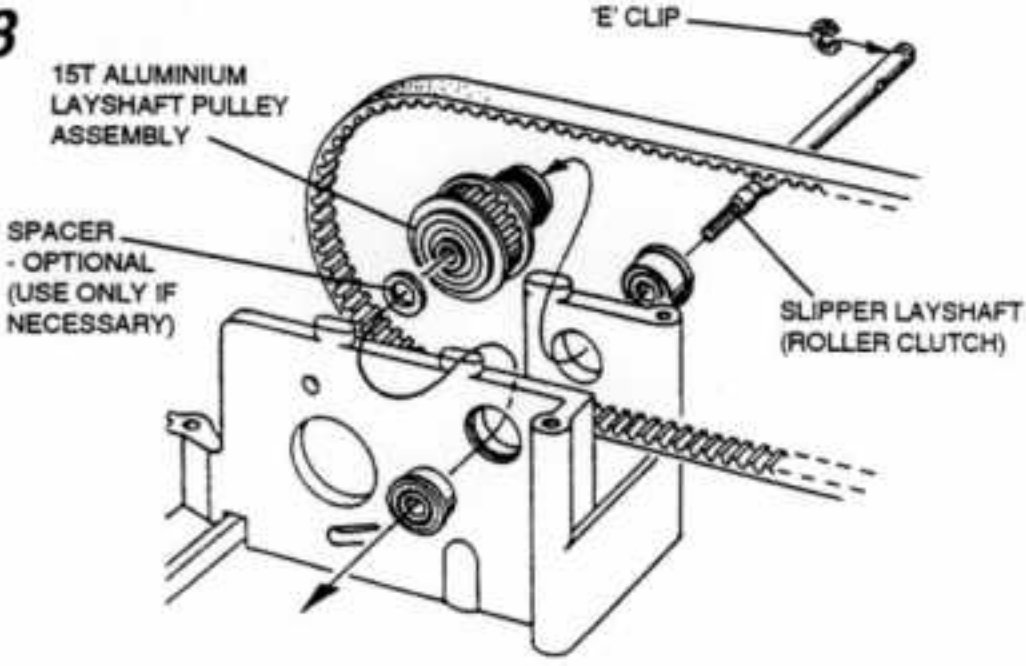

**4**

**OPTIONAL**

THE ONEWAY ROLLER CLUTCH CAN BE LOCKED OUT BY INSERTING A PIN AS SHOWN. THIS IS MAINLY USED WHEN YOU WANT BRAKING ON THE FRONT WHEELS.

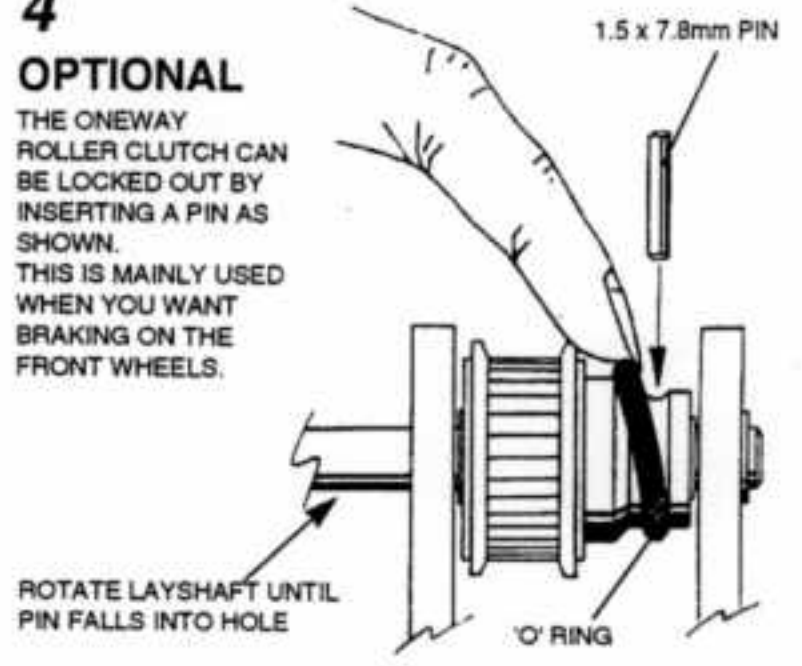

S819

## U1840Q ACKERMANN STEERING MOD

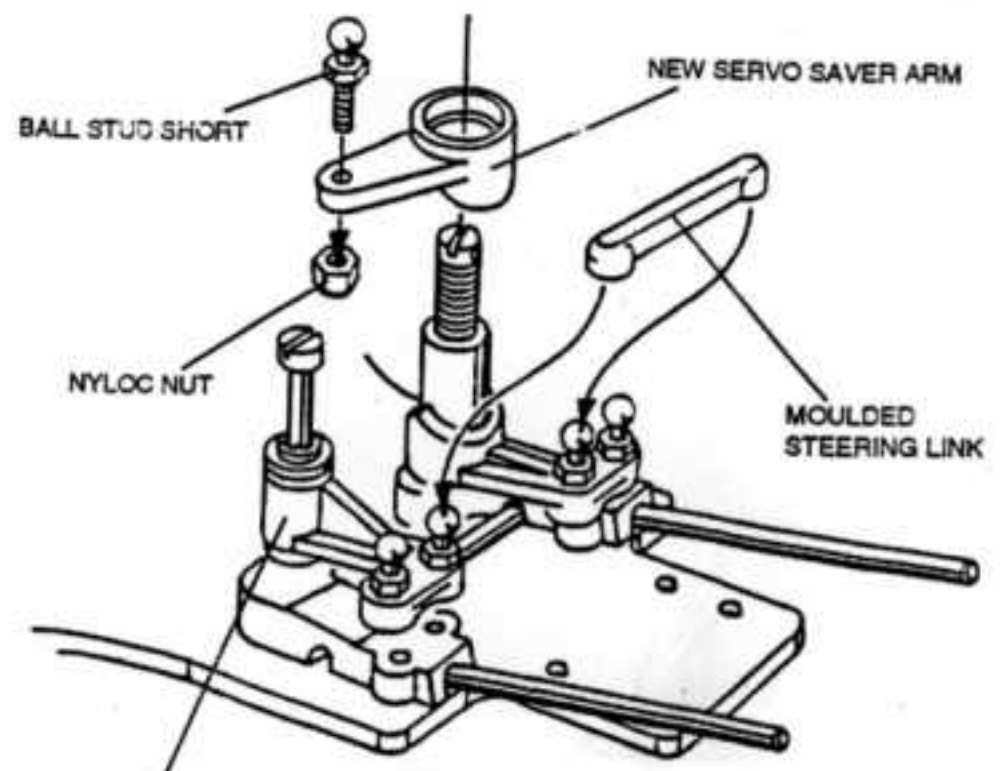
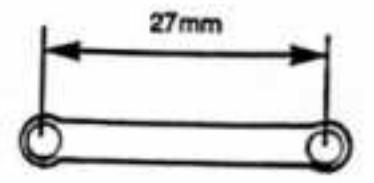

NOTE: REVERSE LEFT & RIGHT STEERING



## CVD DRIVESHAFT INSTRUCTIONS

1. Spread a thin layer of MIP CVD lube on coupling, and insert into axle.
2. Slide completed axle into shaft with the cross holes in coupling and shaft aligned.
3. Insert the cross pin, and make sure it is evenly spaced on both sides of the shaft.
4. Angle the axle so the grub screw can be screwed in with the allen key. Always use a small amount of threadlock on the grub screw only.

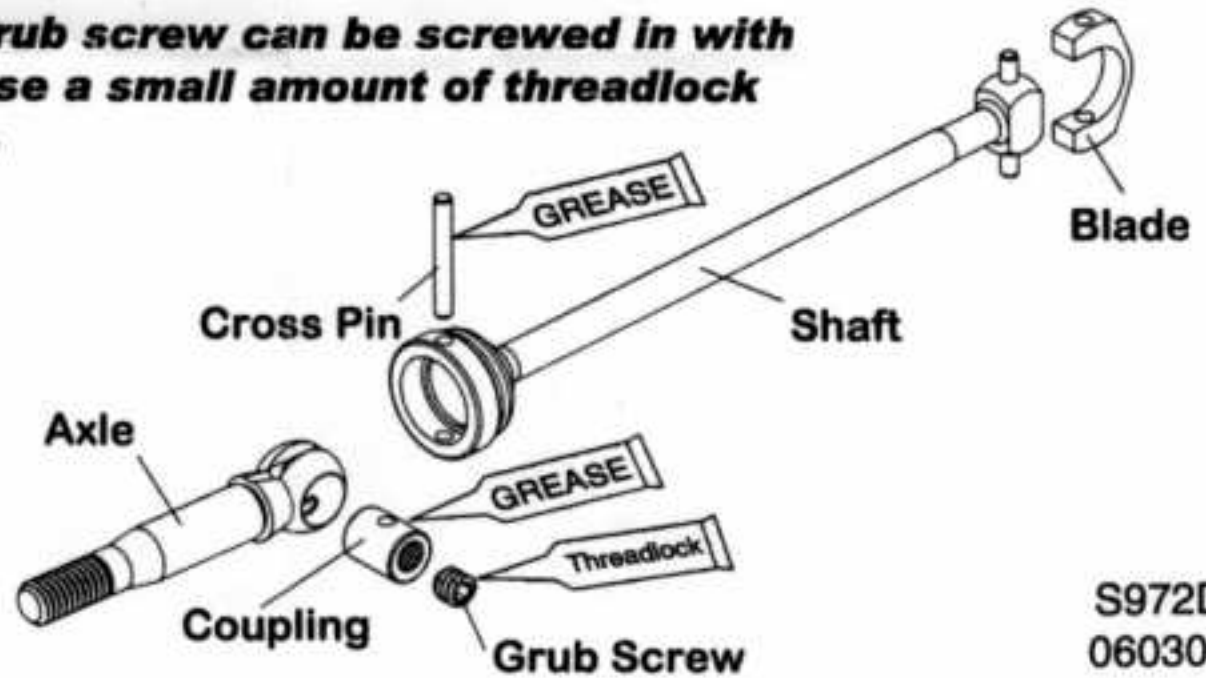

S972D  
060300



**1** CAREFULLY PRESS THE BRASS BUSHES & ONEWAY ROLLER CLUTCH INTO THE LAYSHAFT PULLEY USING A SMALL VICE

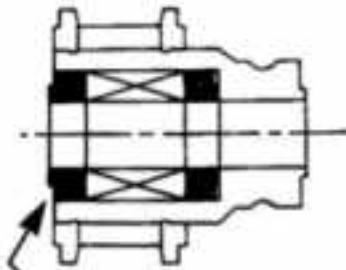
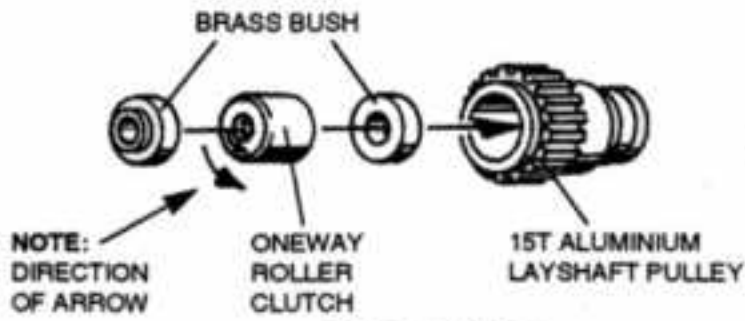

NOTE: DIRECTION OF SHOULDER ON BRASS BUSHES SHOULD BE FLUSH HERE

**WARNING:**

MAKE SURE THE ONEWAY ROLLER CLUTCH IS FITTED THE CORRECT WAY ROUND - ONCE ITS IN YOU WON'T BE ABLE TO GET IT OUT

**2**

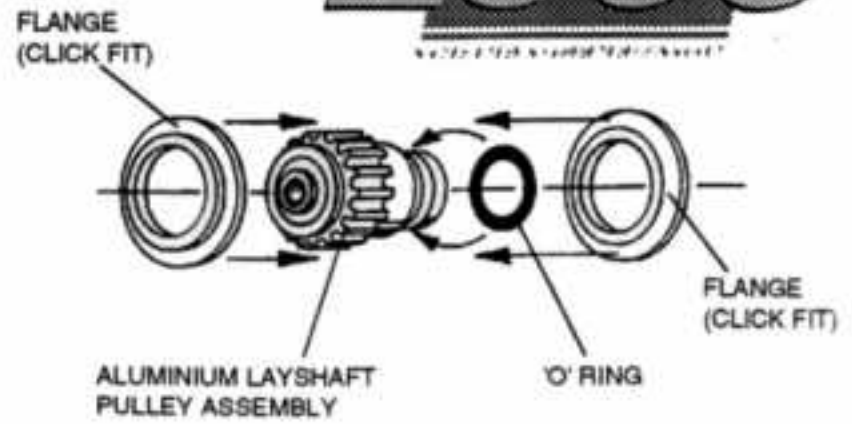

**3**

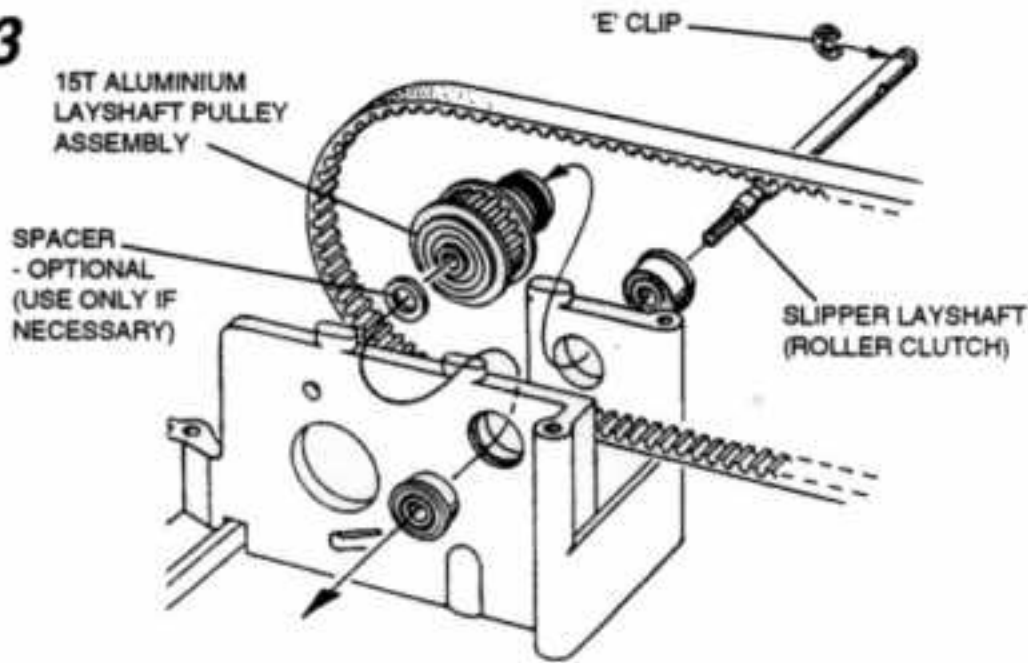

**4**

**OPTIONAL**

THE ONEWAY ROLLER CLUTCH CAN BE LOCKED OUT BY INSERTING A PIN AS SHOWN. THIS IS MAINLY USED WHEN YOU WANT BRAKING ON THE FRONT WHEELS.

