

# Schumacher

## COUGAR R ZUUU



CONTENTS	PAGE
CHASSIS & STEERING SERVO	1
TRANSMISSION	2
FRONT SUSPENSION	5-8
REAR SUSPENSION	9-10
SHOCK ABSORBERS	11-13
WHEELS & TYRES	14
BODYSHELL	15
FRONT & REAR BUMPERS	16
FITTING NICADS	17
WING MOUNT & GEAR COVER	18
FITTING ELECTRICS	19
SERVICING	20
TRACK SETTINGS	21

In line with our policy of continuous development the exact specification of the kit may vary

#### MISSING OR DEFECTIVE PARTS

In the unlikely event of problems with your new kit you should contact the model shop where purchased, quoting part number, bag number and hatch number for both the bag and the kit

#### SCHUMACHER RACING PRODUCTS

71-73 Tenter Road, Moulton Park, Northampton, NN3 6AX, ENGLAND

#### SCHUMACHER USA

6302 Benjamin Road, Suite 404, Tampa, Florida 33634, USA

INSTRUCTION MANUAL

### IMPORTANT SAFETY NOTES

1. This product is not suitable for children under 14 years of age unless supervised by an adult.
2. Select an area for assembly that is away from reach of small children. The parts are small and can be swallowed by children causing choking and possible internal injuries.
3. Shock fluids, grease and adhesives should be kept out of childrens reach. They are not toxic, but were not intended for human consumption.
4. Exercise care when using any hand tools, sharp instruments and power tools during construction.
5. Carefully read all manufacturers warnings and cautions for any glues or paints that may be used for assembly purposes.



Places to put threadlock.  
(It will prevent the screws and nuts vibrating loose.)



Points where grease should be applied. (It will reduce friction and assure smooth movement.)



Points where oil should be applied (Light machine oil, 3 in 1 or similar.)

*Do not use excessive force when tightening the self-tapping screws, or you may strip the thread in the plastic. It is recommended to stop tightening it when the threaded part on the screw goes into the plastic part and you feel some resistance from the tightening.*

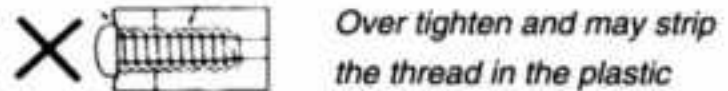
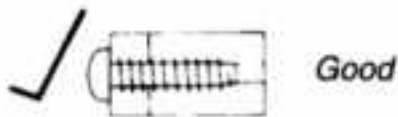

### ADDITIONAL ITEMS REQUIRED

TRANSMITTER

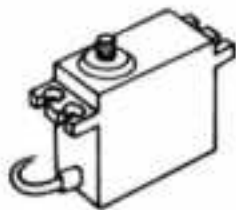
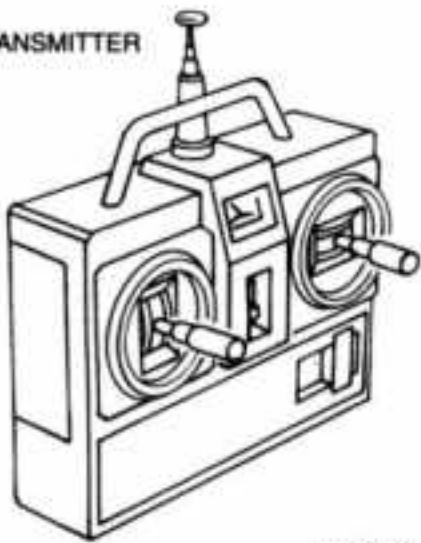

STEERING SERVO

RECEIVER



8 PEN CELLS  
(FOR TRANSMITTER)

MOTOR AND  
PINNION

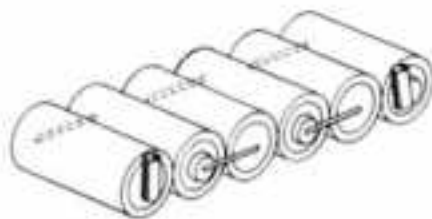
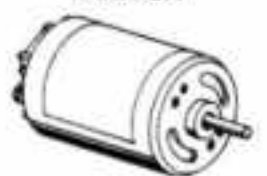

NICADS (STICK OR SADDLE PACK)



SPEED CONTROLLER

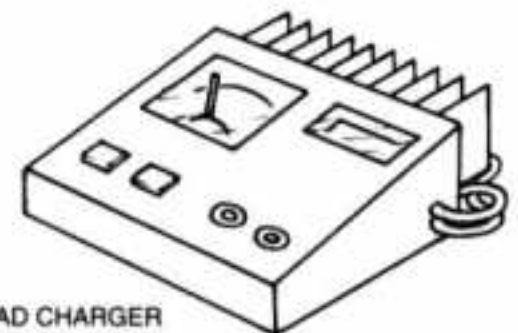

NICAD CHARGER

**FOR BEST PERFORMANCE, IT IS VERY IMPORTANT THAT GREAT CARE IS TAKEN TO ENSURE THE FREE MOVEMENT OF ALL PARTS.**

### TOOLS REQUIRED

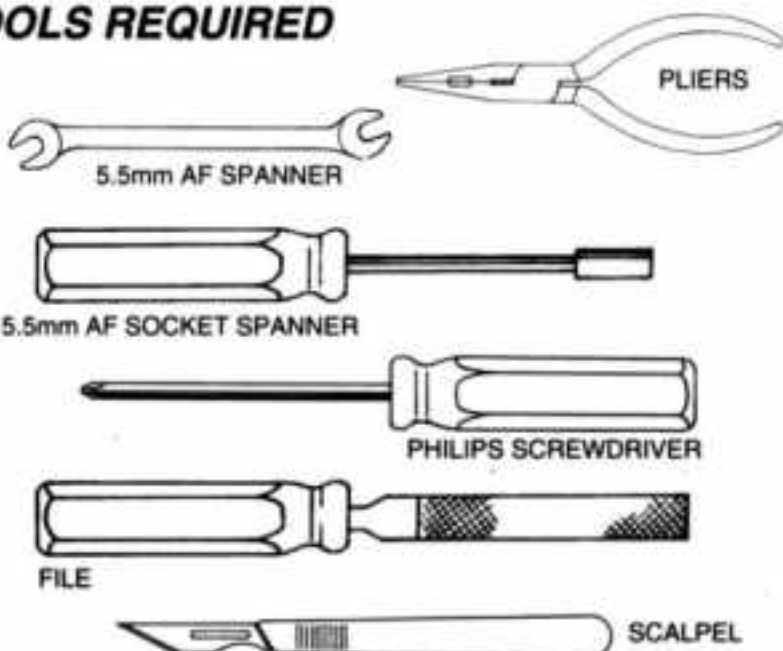

### MATERIALS REQUIRED

Threadlock  
Light oil for shock absorbers  
Polycarbonate paint for bodyshell  
Grease

### RULER INCHES & MILLIMETRES

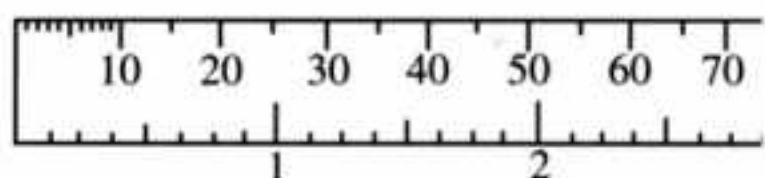

**CHASSIS**

**HARDWARE**

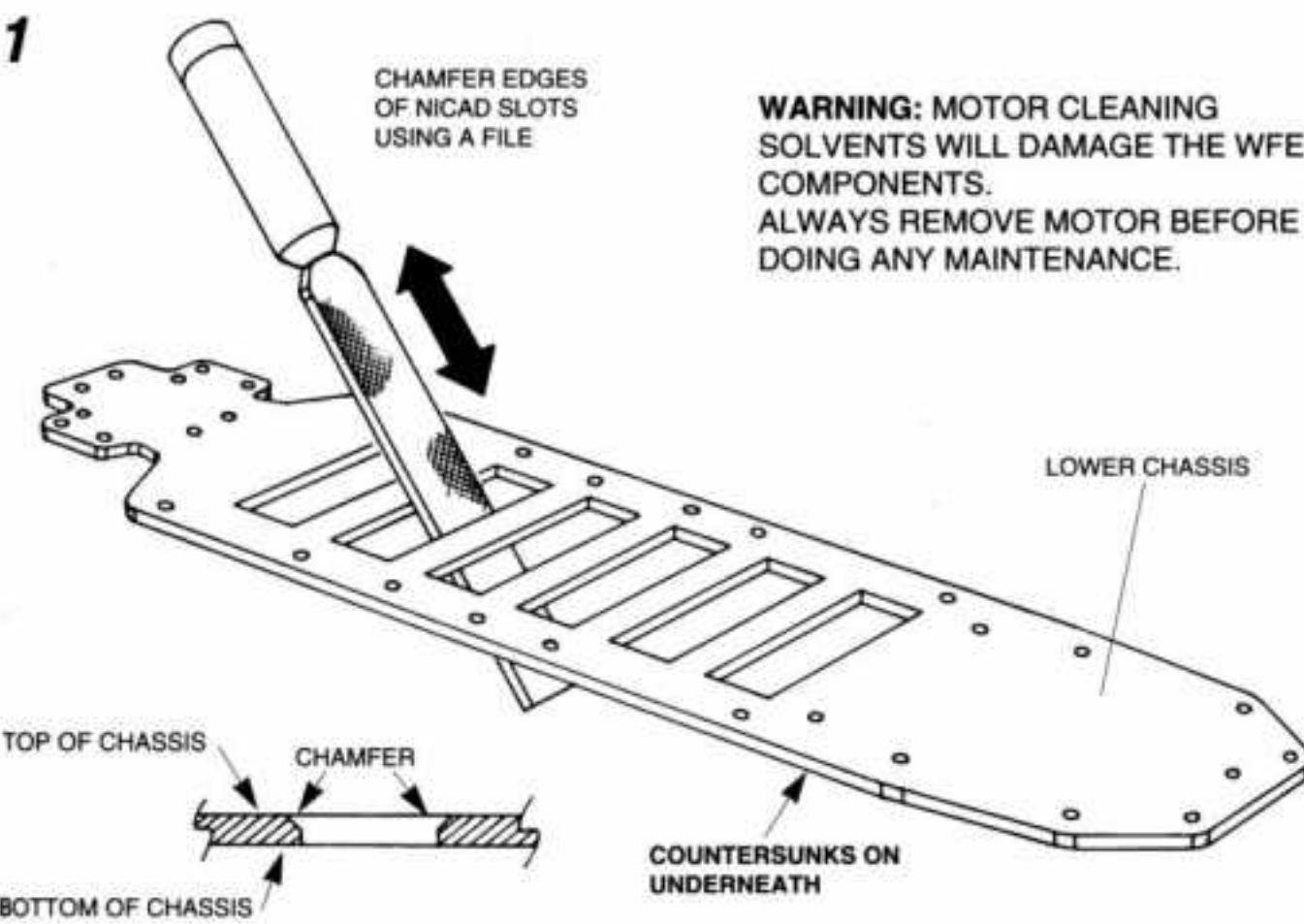

A333 No4x3/8" SELFTAP CSK SCREW  
X10

A023 M3x12mm CSK SCREW  
X2

A051 M3 NYLOC NUT  
X2

A225 M3 STEEL WASHER  
X4

A323 No4x3/8" SELFTAP PANHD SCREW  
X2

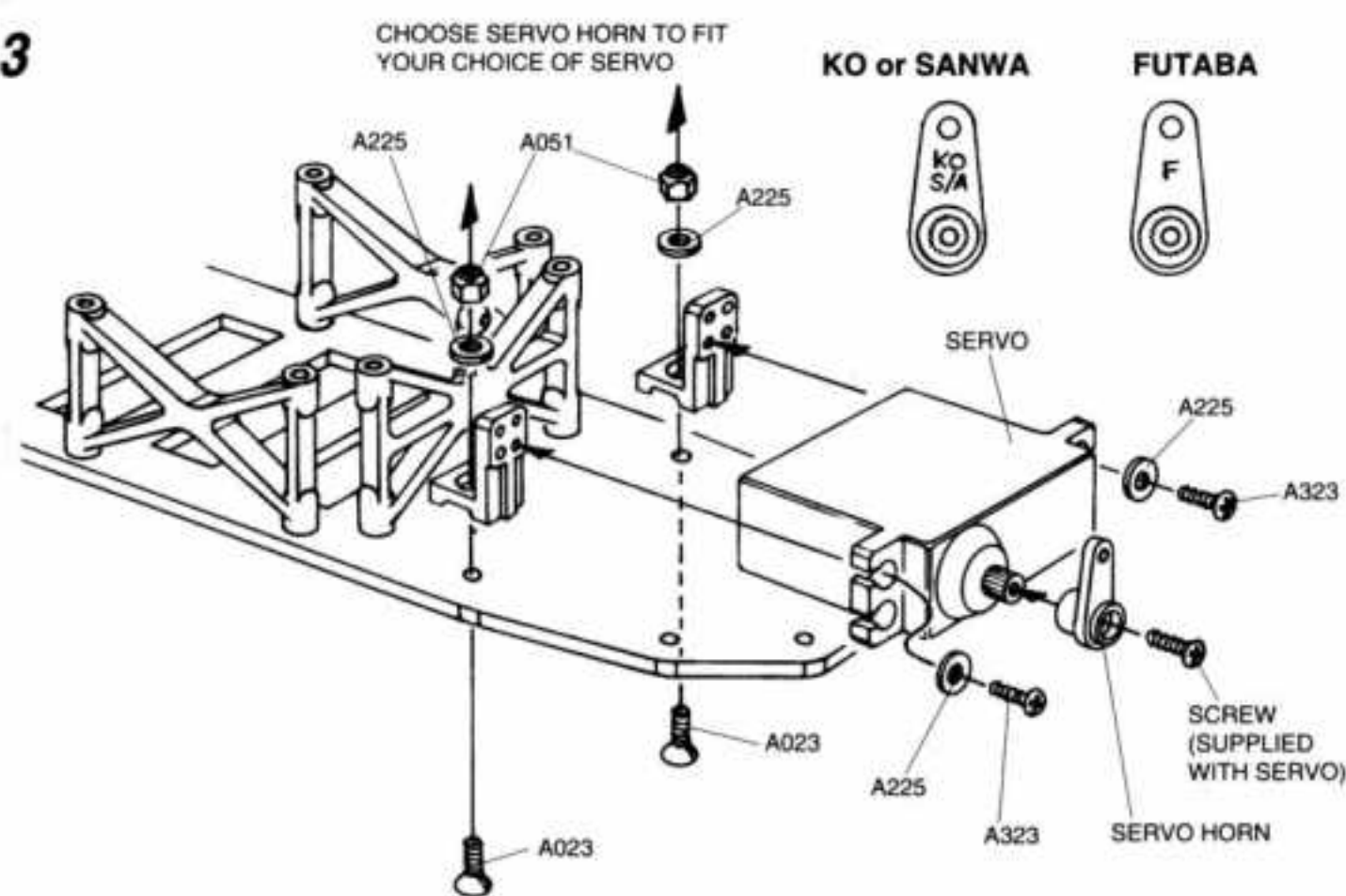
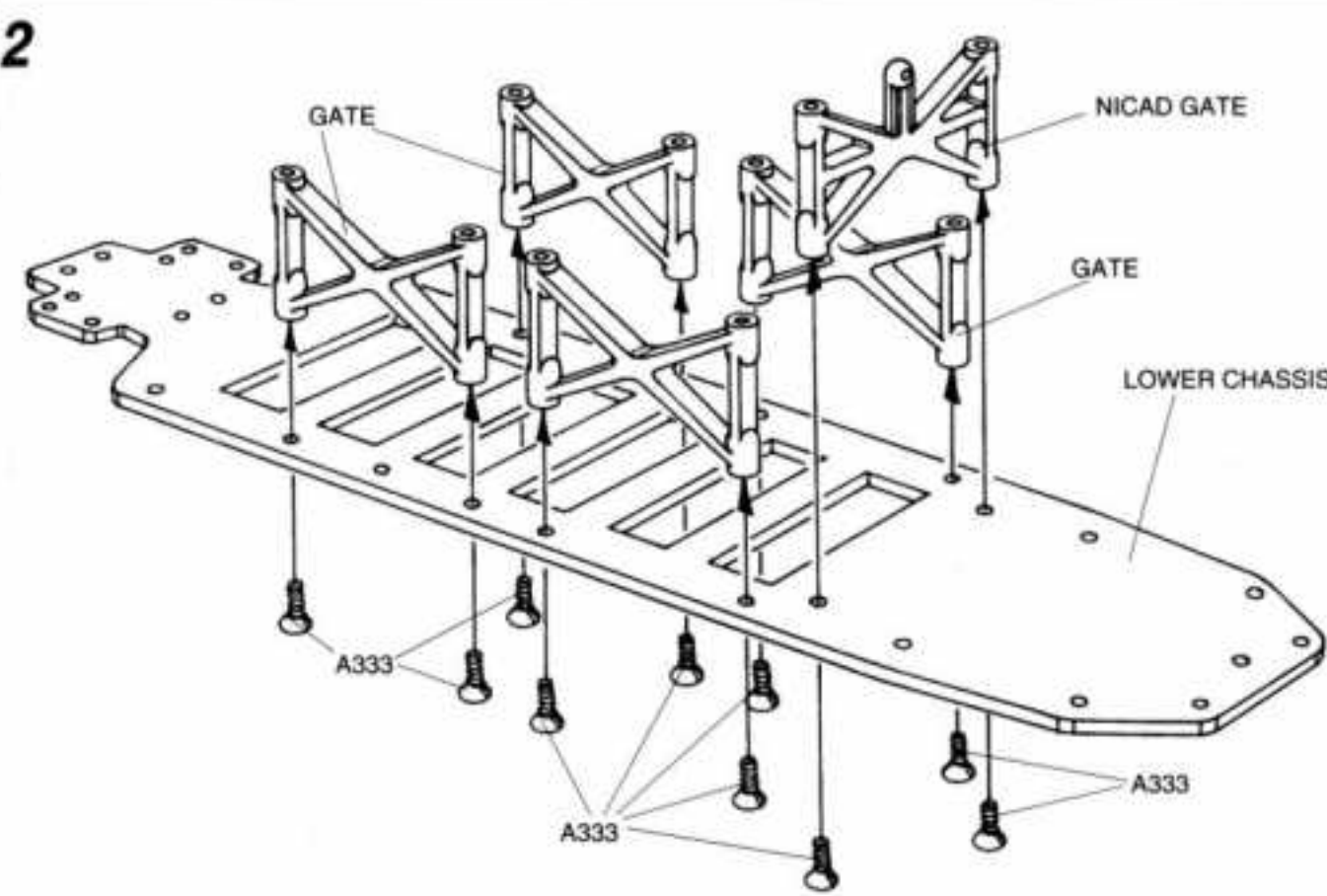

**YOUR DIFFERENTIAL MAY BE PREASSEMBLED. IF SO USE THESE STEPS 1 - 13 FOR SERVICING.**

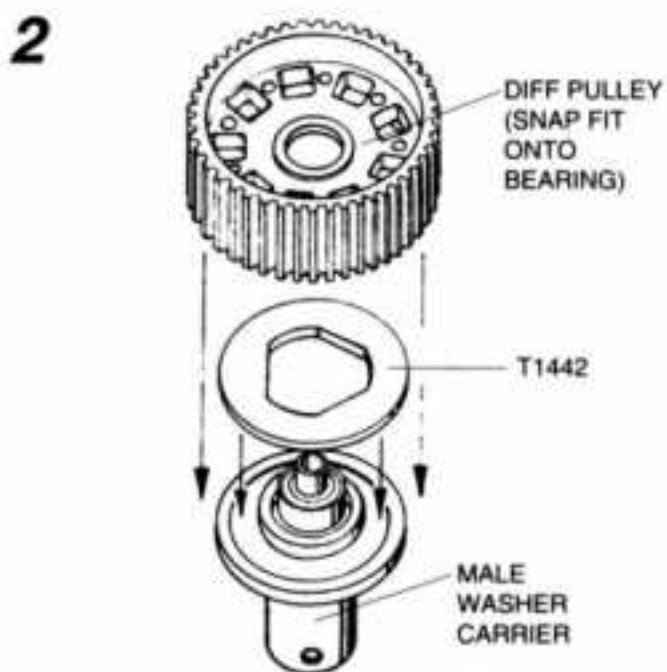
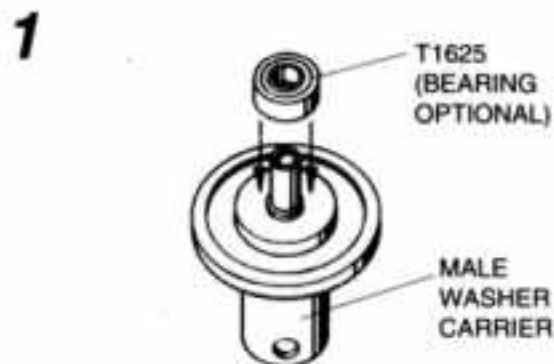

**TRANSMISSION**

**HARDWARE**

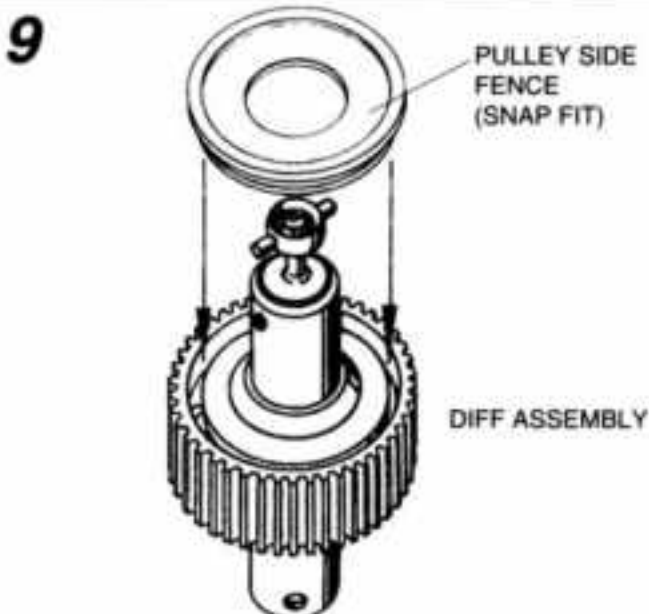
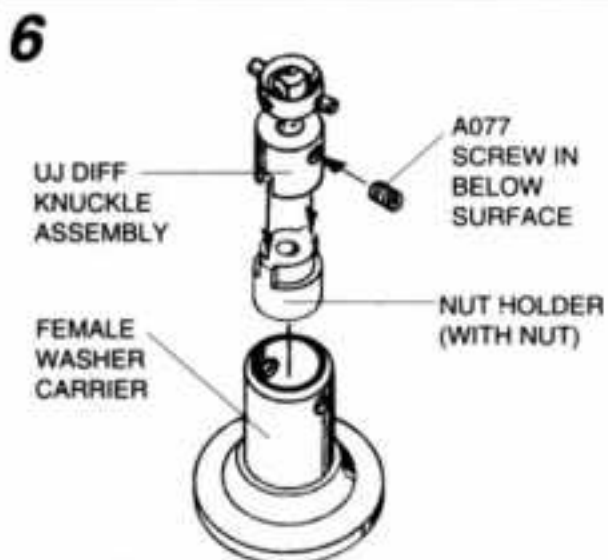
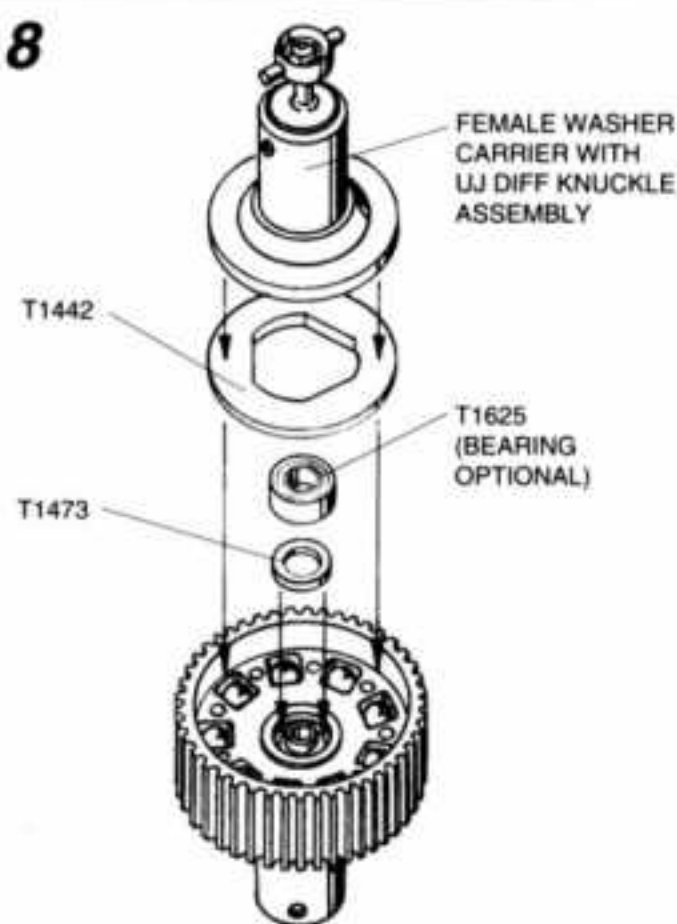
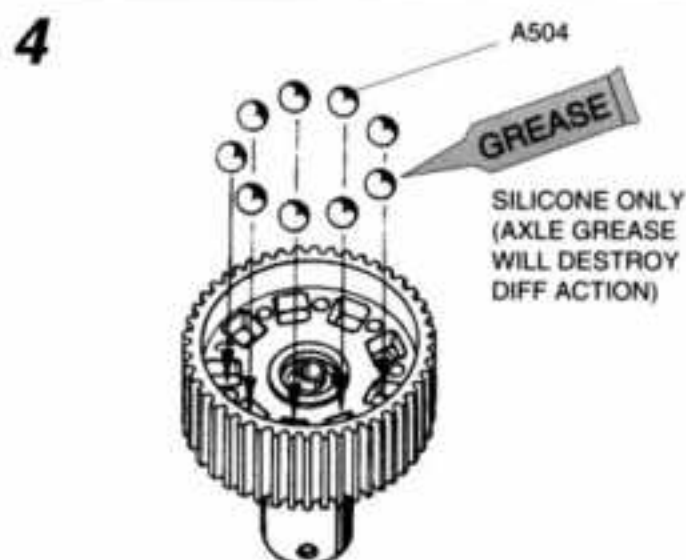
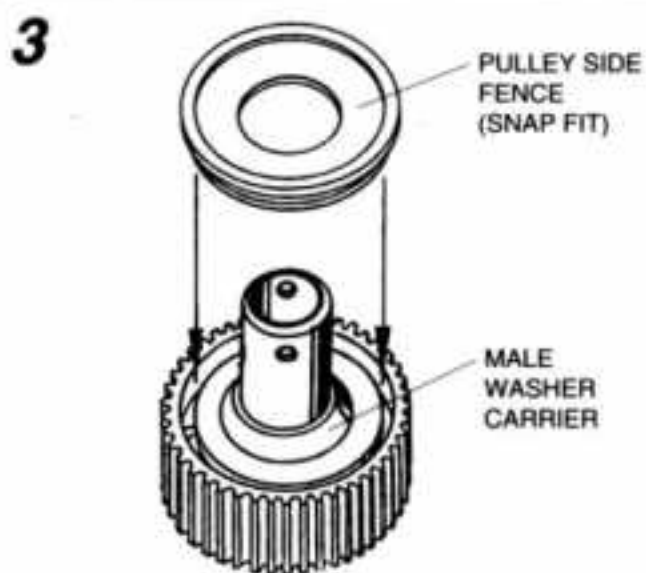
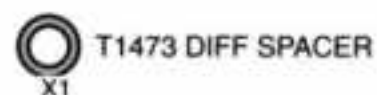
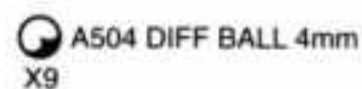



18

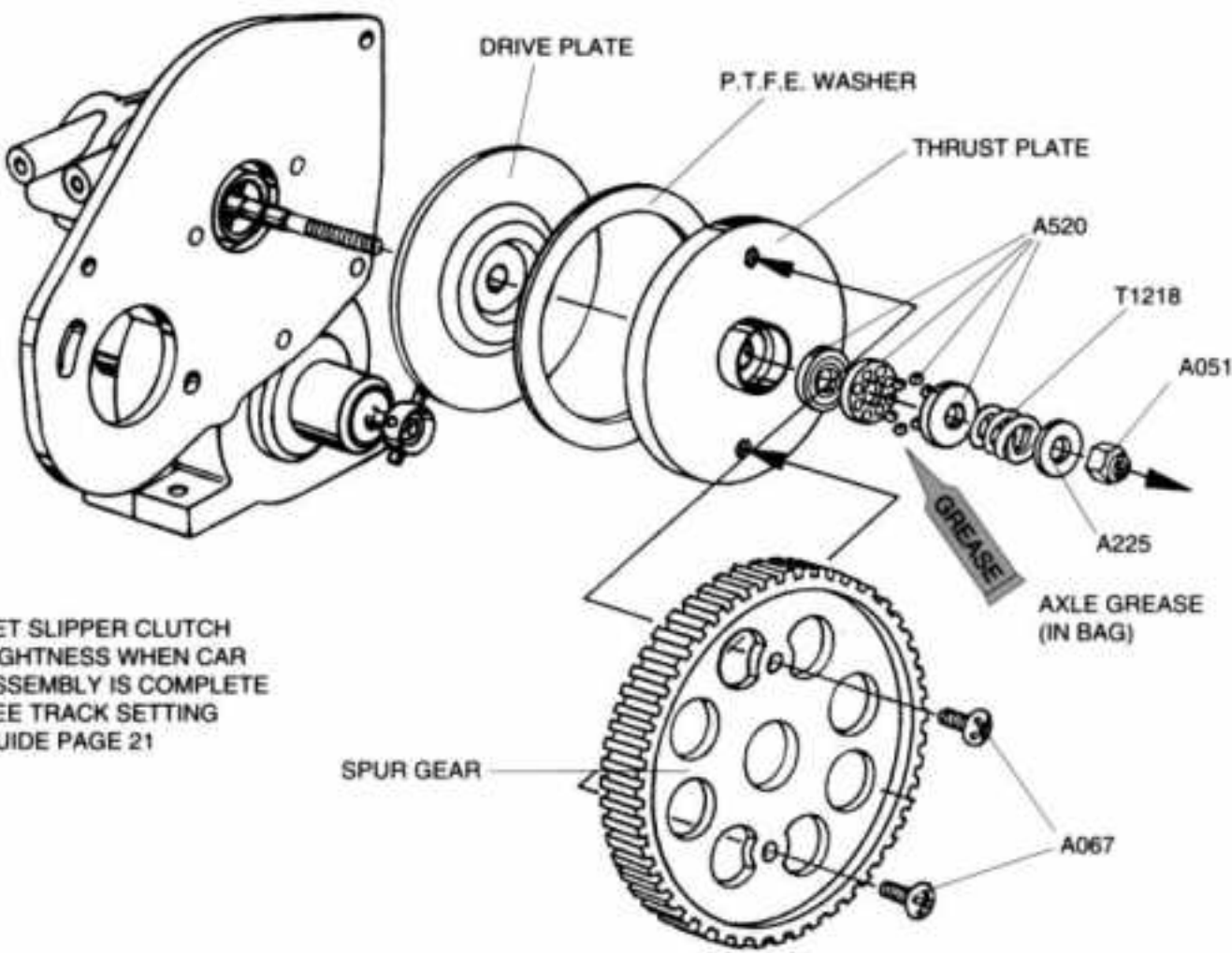

SET SLIPPER CLUTCH TIGHTNESS WHEN CAR ASSEMBLY IS COMPLETE SEE TRACK SETTING GUIDE PAGE 21

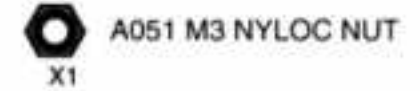
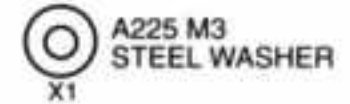
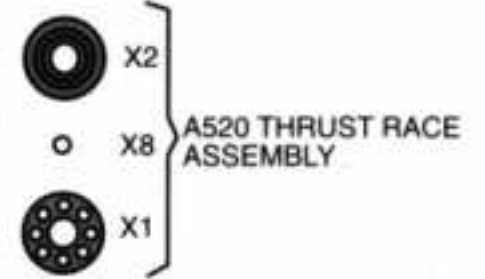

19 CO-AXIAL DRIVESHAFTS

ASSEMBLE ONE DRIVESHAFT AT A TIME

REMOVE DIFF KNUCKLE ASSEMBLY FROM ONE SIDE OF DIFF. ASSEMBLE DRIVESHAFT THEN RE-ATTACH TO DIFF IN TRANSMISSION.

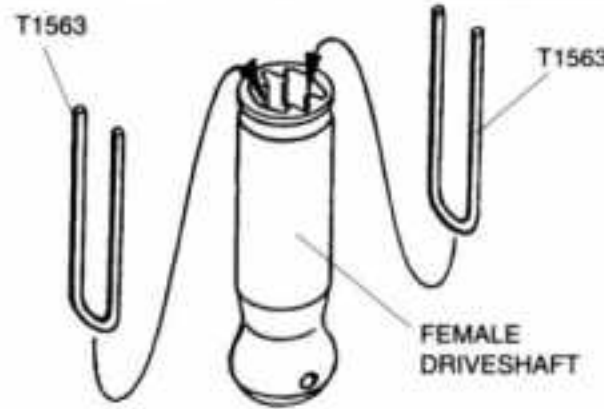

20 UNIVERSAL JOINT - KNUCKLE ASSEMBLY

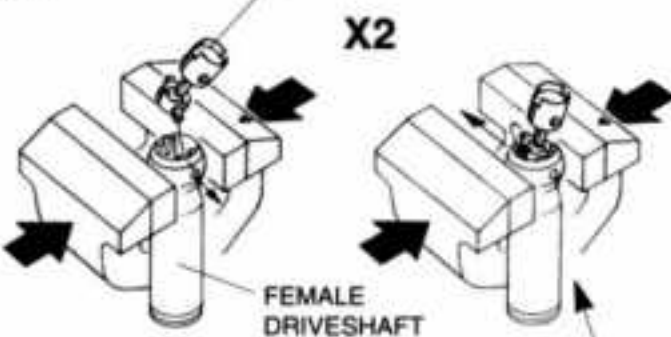

CLAMP GENTLY TO FLEX MOULDING SO CRUXIFORM JUST FITS IN. (USE SMALL VICE OR PLIERS)

UNIVERSAL JOINT WILL SNAP FIT IN

WARM UP MOULDINGS IN HOT WATER FIRST TO EASE ASSEMBLY

21 UNIVERSAL JOINT - LIVE AXLE ASSEMBLY

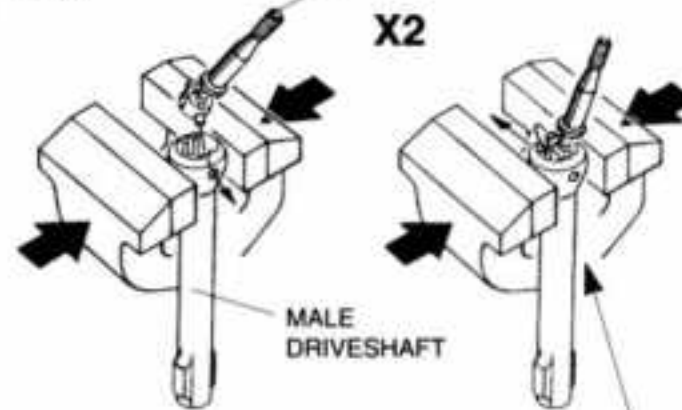

CLAMP GENTLY TO FLEX MOULDING SO CRUXIFORM JUST FITS IN. (USE SMALL VICE OR PLIERS)

UNIVERSAL JOINT WILL SNAP FIT IN

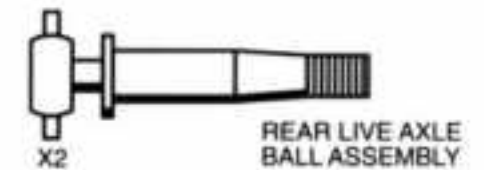

22

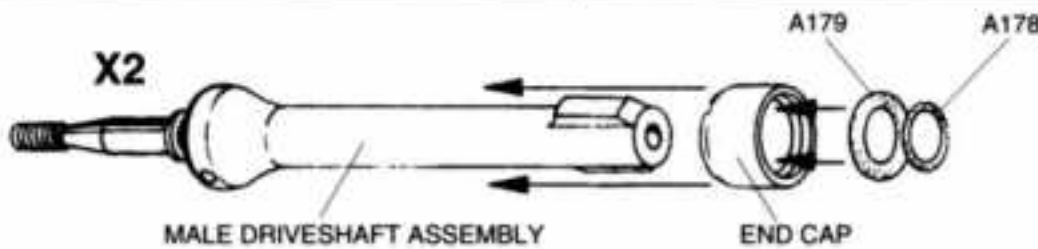

23

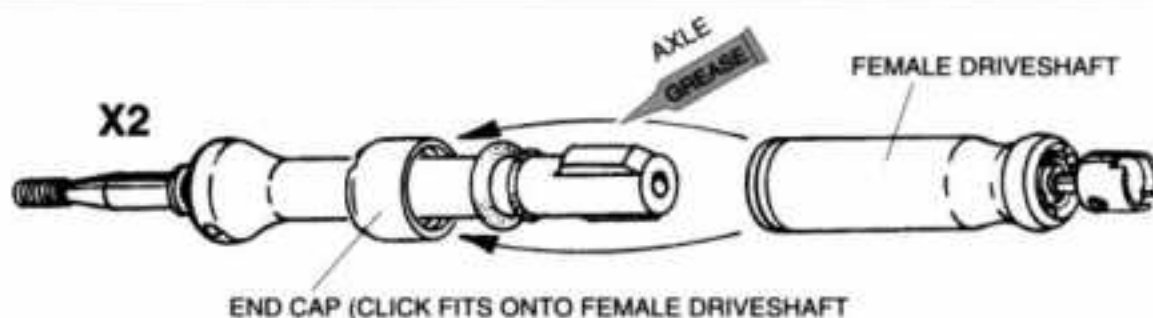

FRONT SUSPENSION

HARDWARE

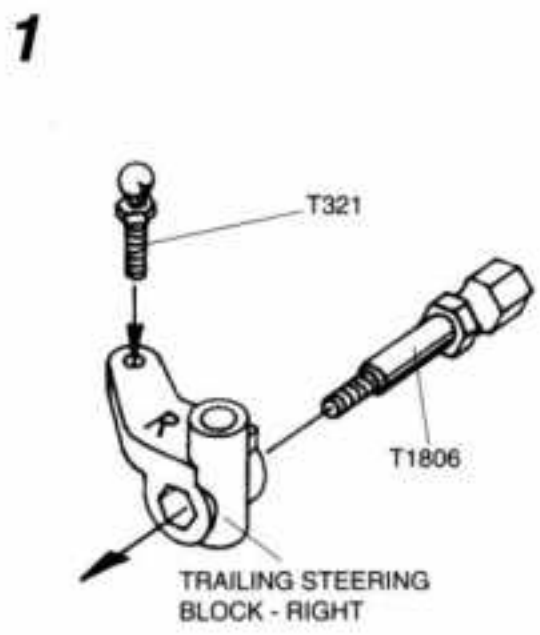

REPEAT FOR LEFTHAND SIDE

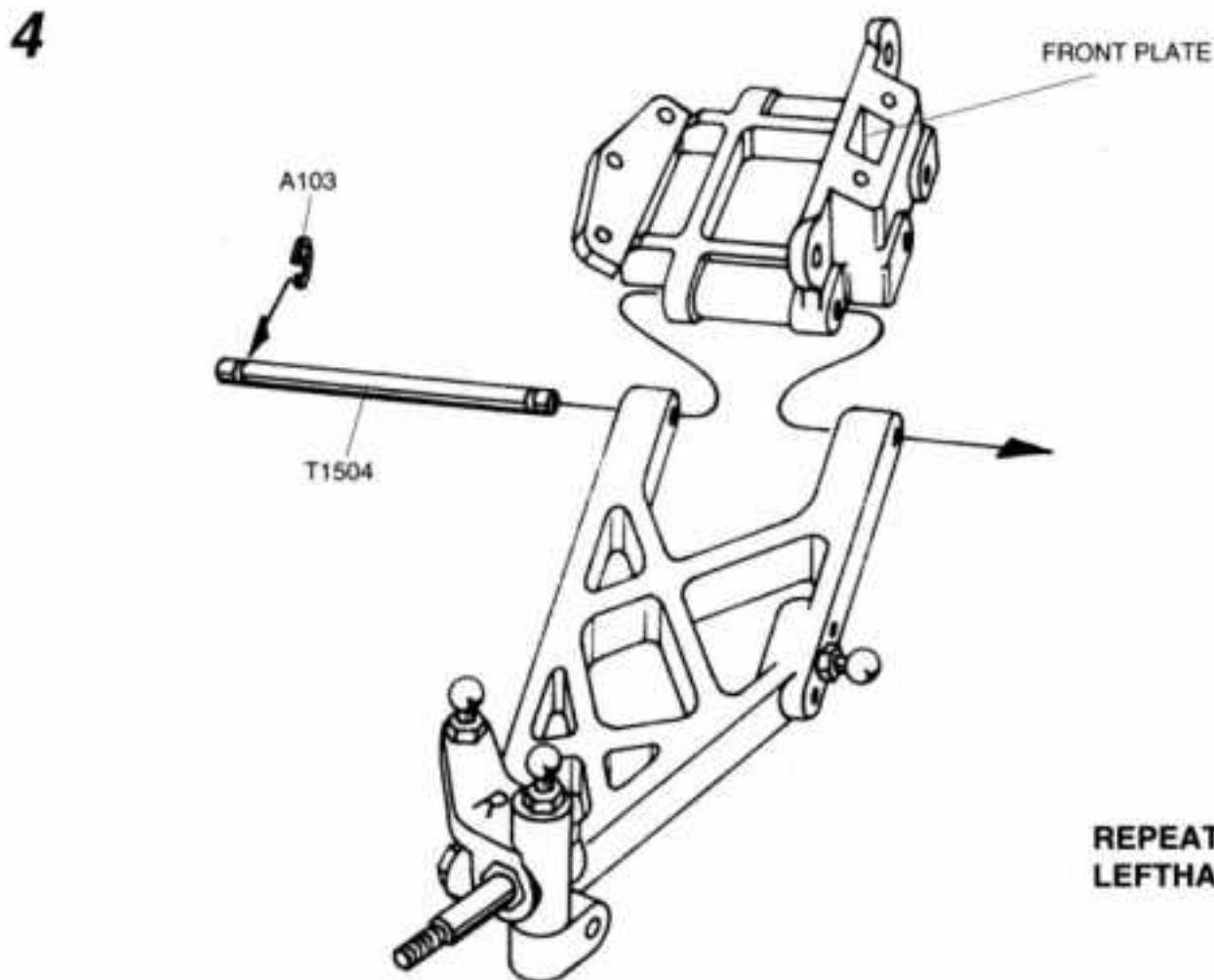
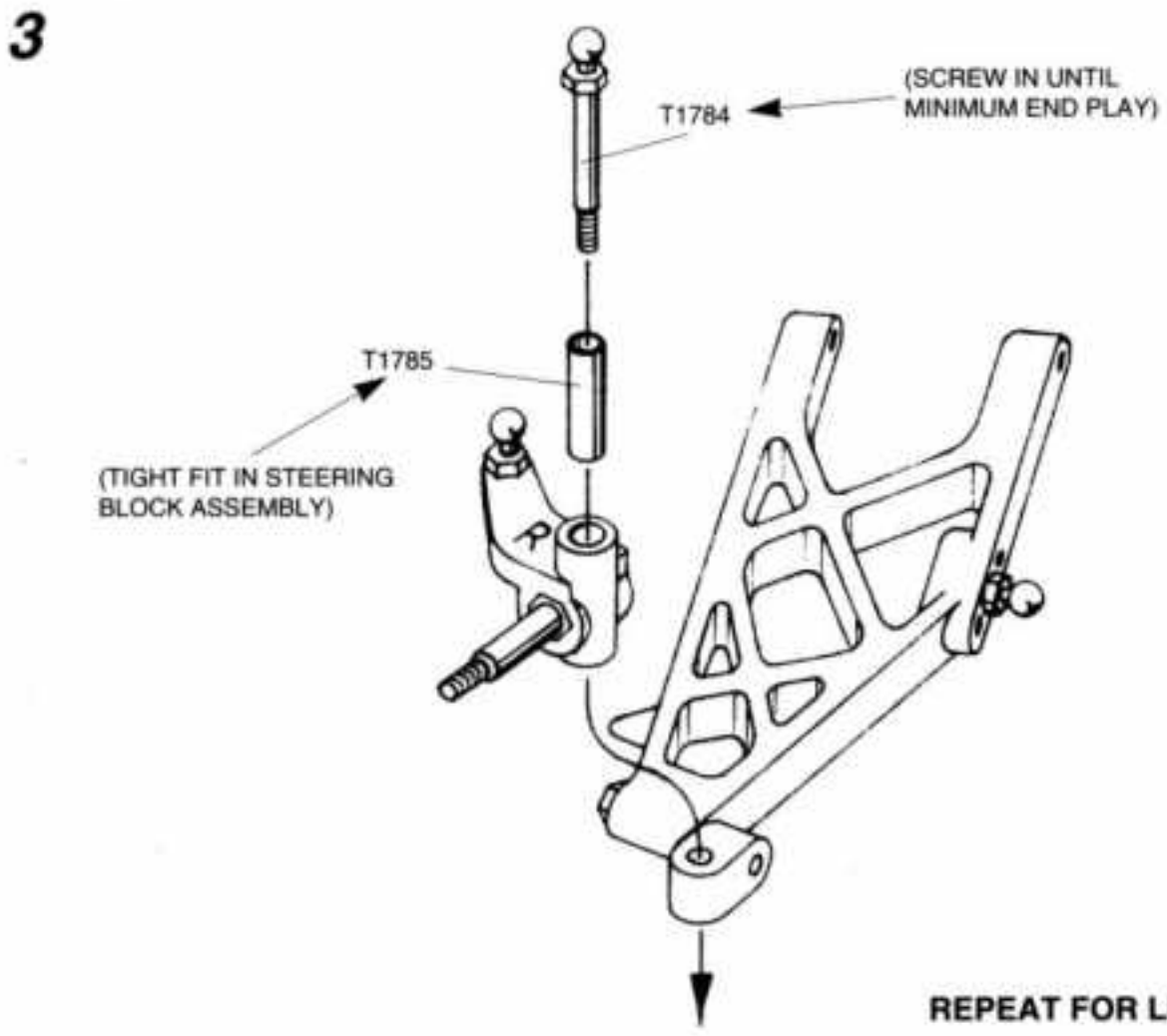
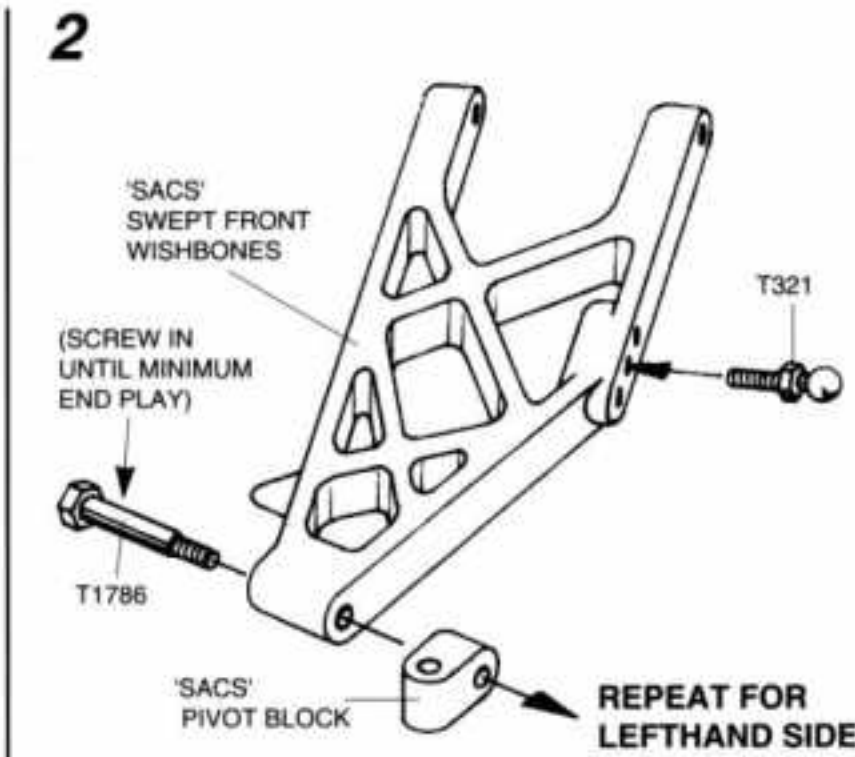

- T321 BALL STUD SHORT
- T1806 TRAILING DEAD AXLE X2
- T1786 SACS PIVOT PIN X2
- T1784 SACS BALL JOINT PIVOT X2
- T1785 STEERING BLOCK TUBE X2
- T1504 FRONT PIVOT PIN - INBOARD X2
- A103 'E' CLIP

5

A010 - ONLY USE TO ALIGN NYLOC NUT

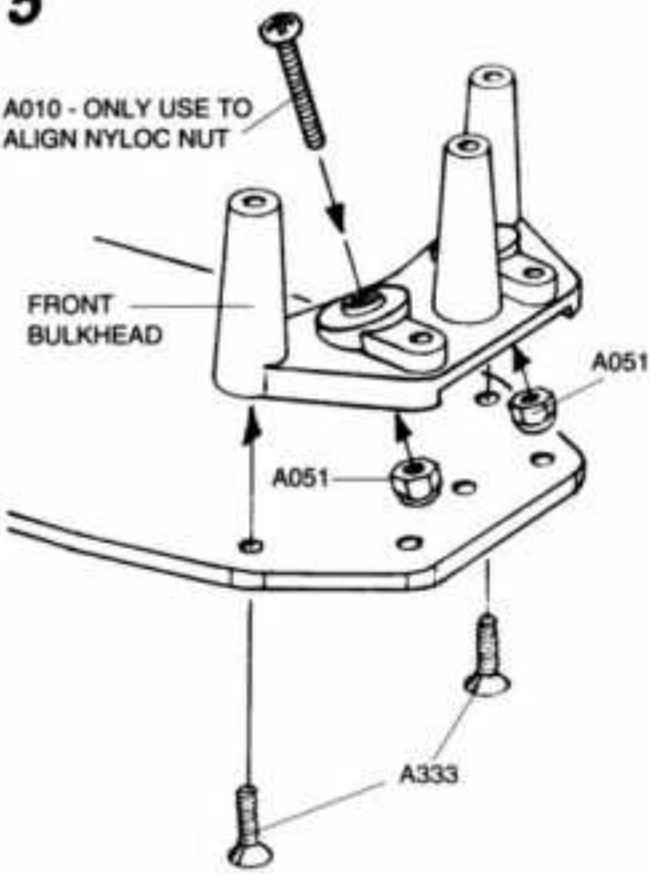

7

STEERING ARM - SERVO SAVER

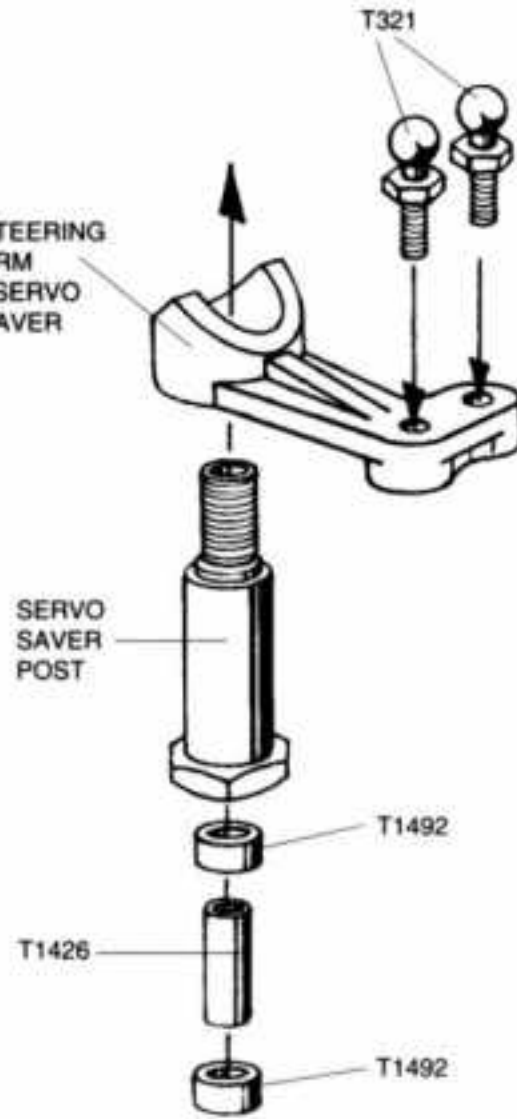

6

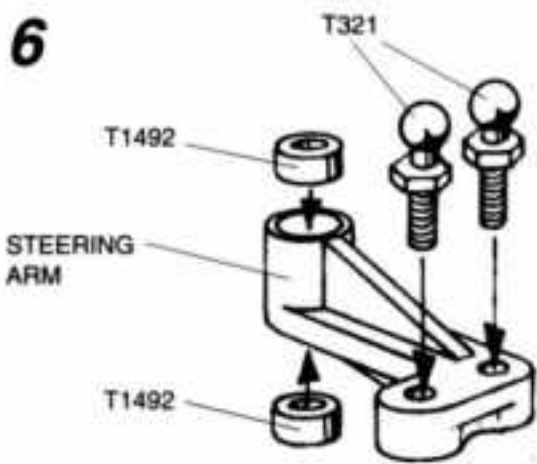

8

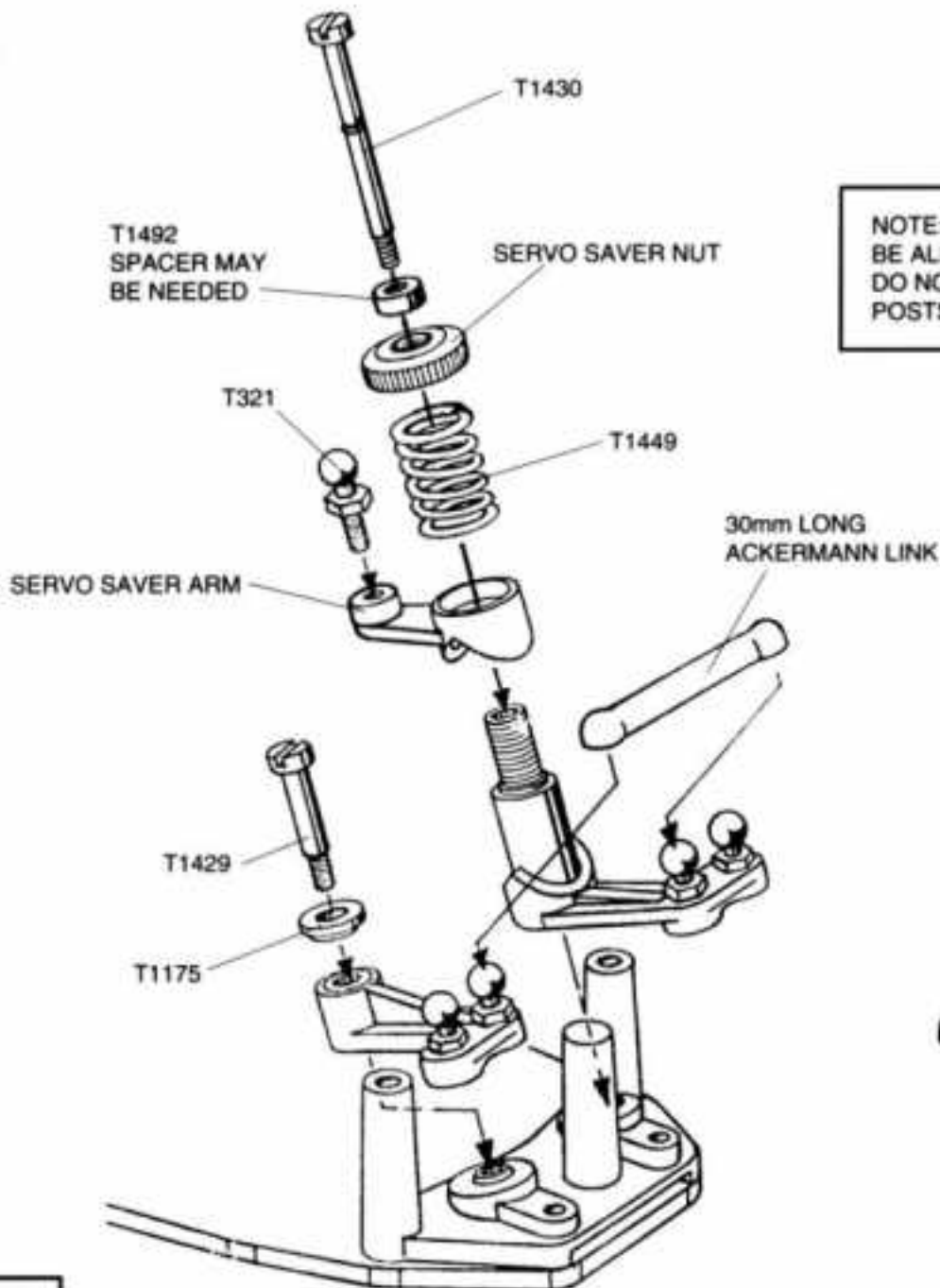

NOTE: STEERING ARMS MUST BE ALLOWED TO MOVE FREELY DO NOT SCREW STEERING POSTS TIGHT

THERE ARE 2 SIZES SEE TRACK SETTINGS FOR MORE DETAIL

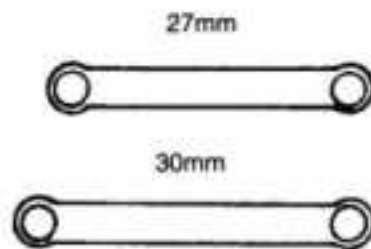

FRONT SUSPENSION

HARDWARE

A051 M3 NYLOC NUT X2

A010 M3x20mm PANHD SCREW X1

A333 No4x3/8" SELFTAP CSK SCREW X2

T321 BALL STUD SHORT X5

T1492 STEERING LEVER BUSH X4

T1462 SPACER TUBE X1

T1430 STEERING POST - LONG X1

T1429 STEERING POST - SHORT X1

T1175 STEPPED WASHER X1

T1449 SERVO SAVER SPRING X1

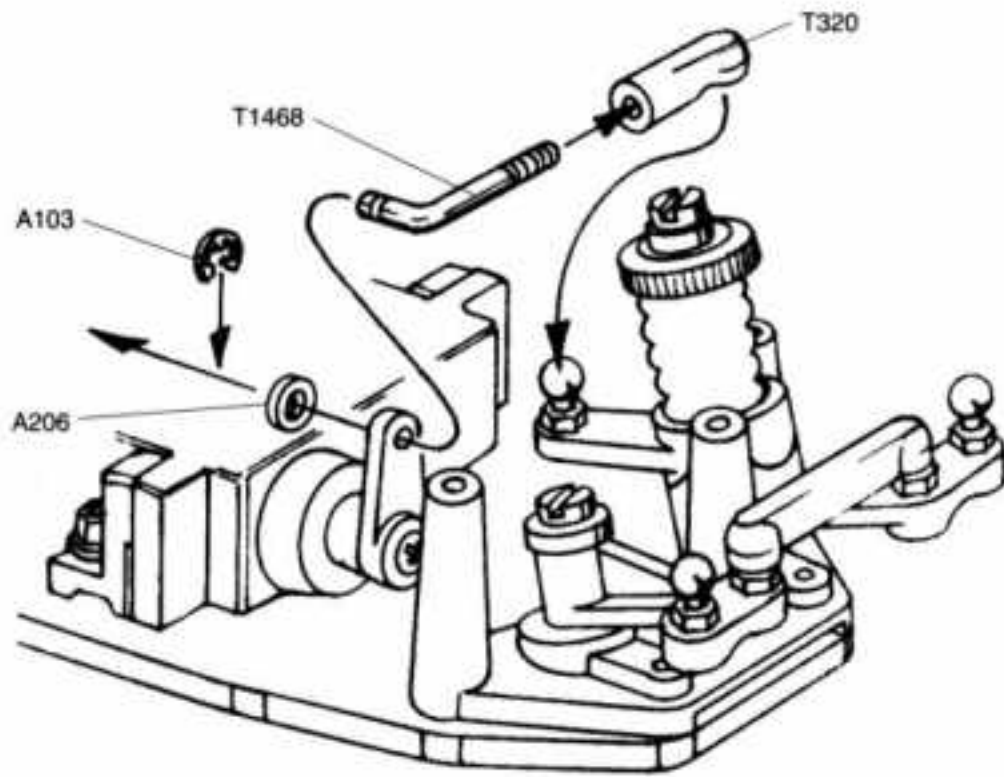

**FRONT SUSPENSION**

**HARDWARE**

X1 T1468 SERVO LINK WIRE

X1 T320 BALL JOINT SOCKET

X1 A103 'E' CLIP

x1 A206 NYLON WASHER 1.6mm

X11 A323 No4x3/8" SELFTAP PANHD SCREW

X2 T321 BALL STUD SHORT

X2 A051 M3 NYLOC NUT

X3 A324 No4x1/2" SELFTAP PANHD SCREW

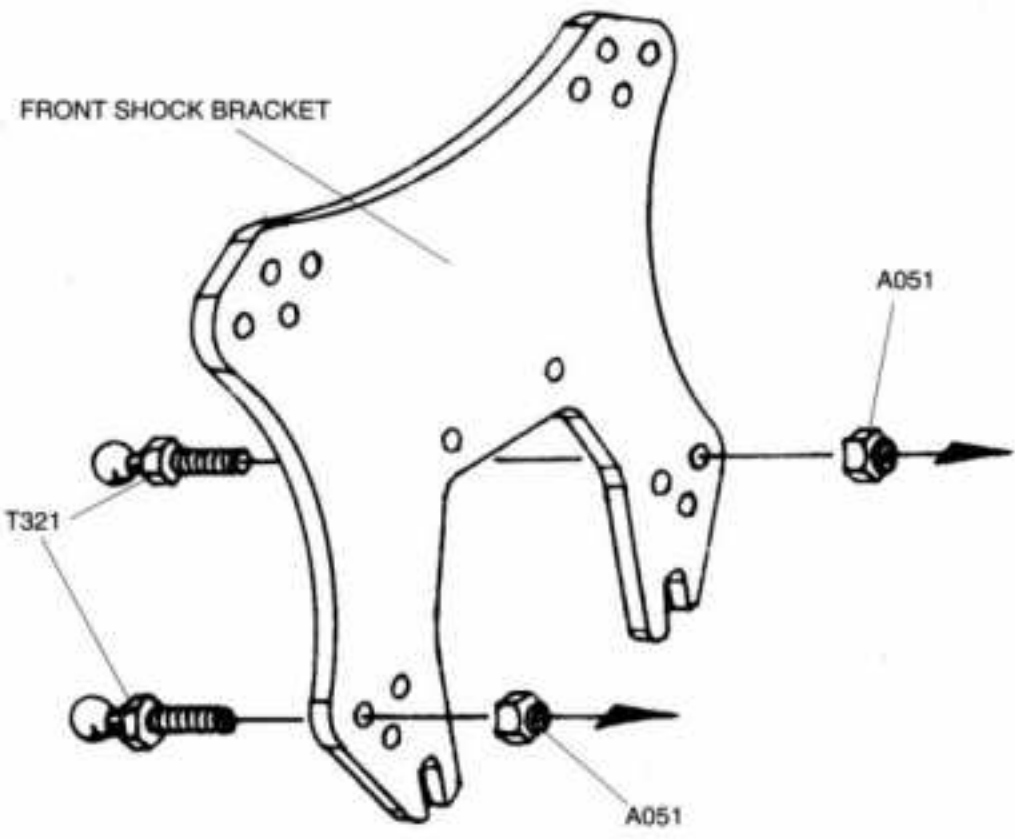
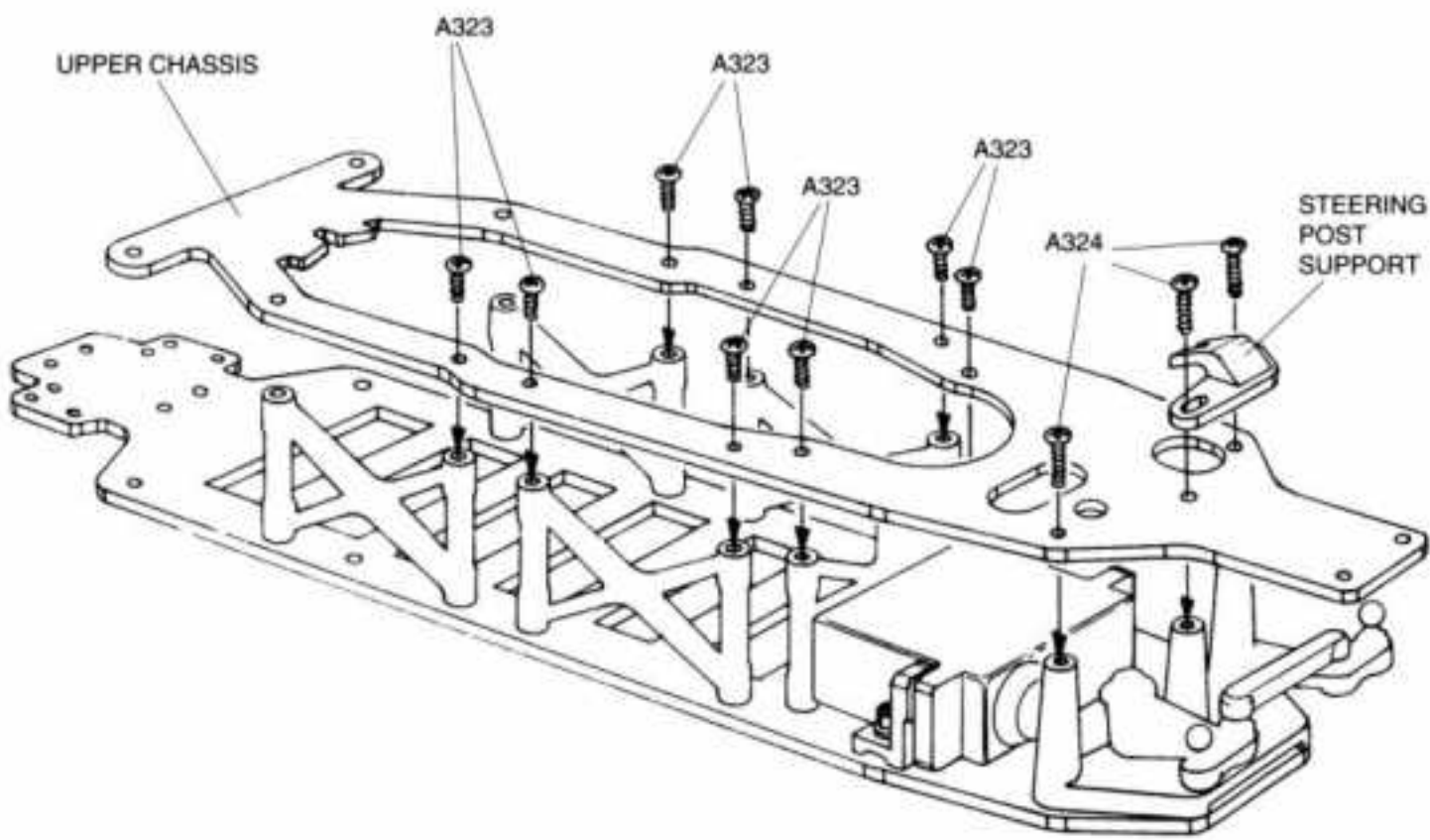

12

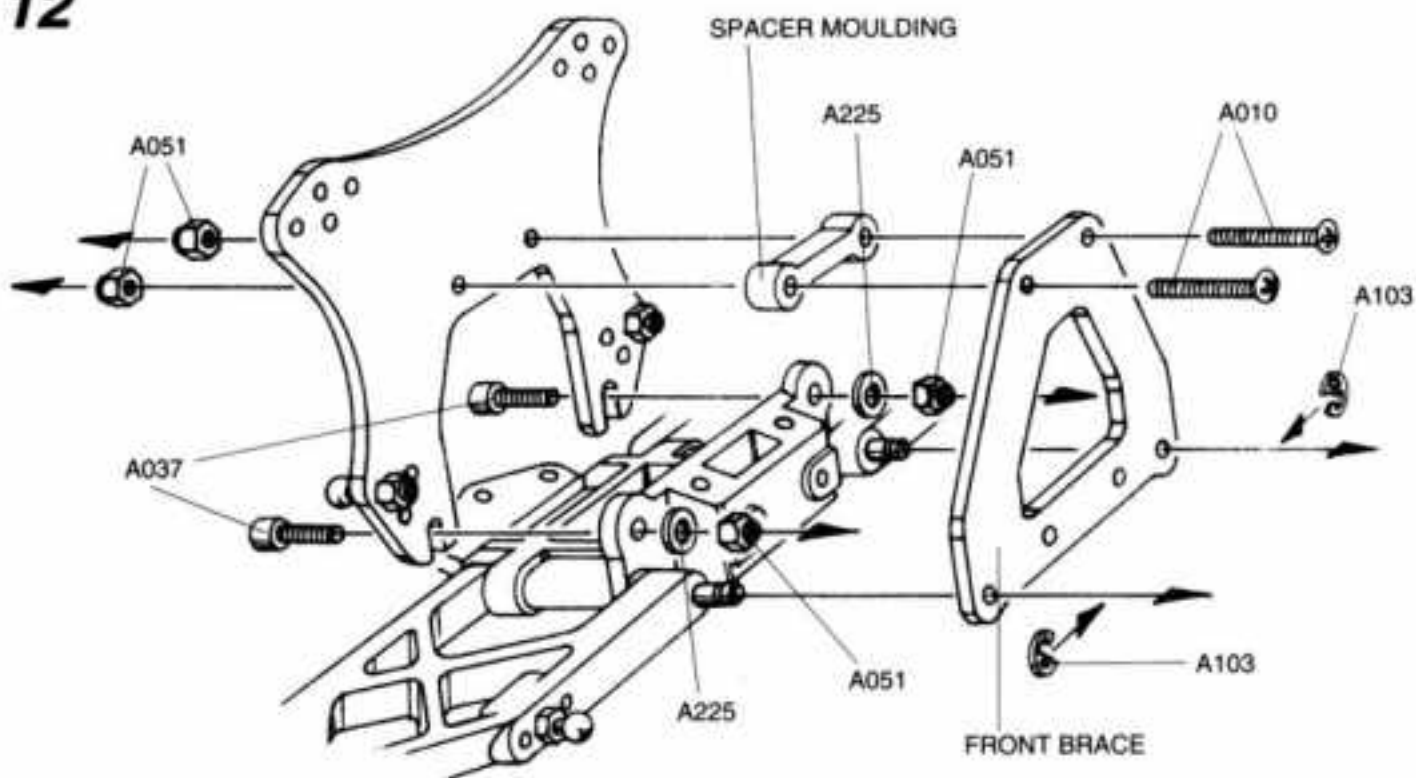

FRONT SUSPENSION

HARDWARE

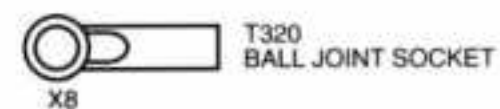
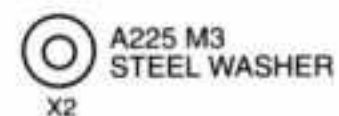
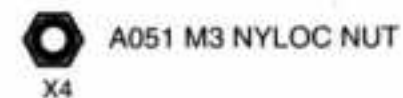

13

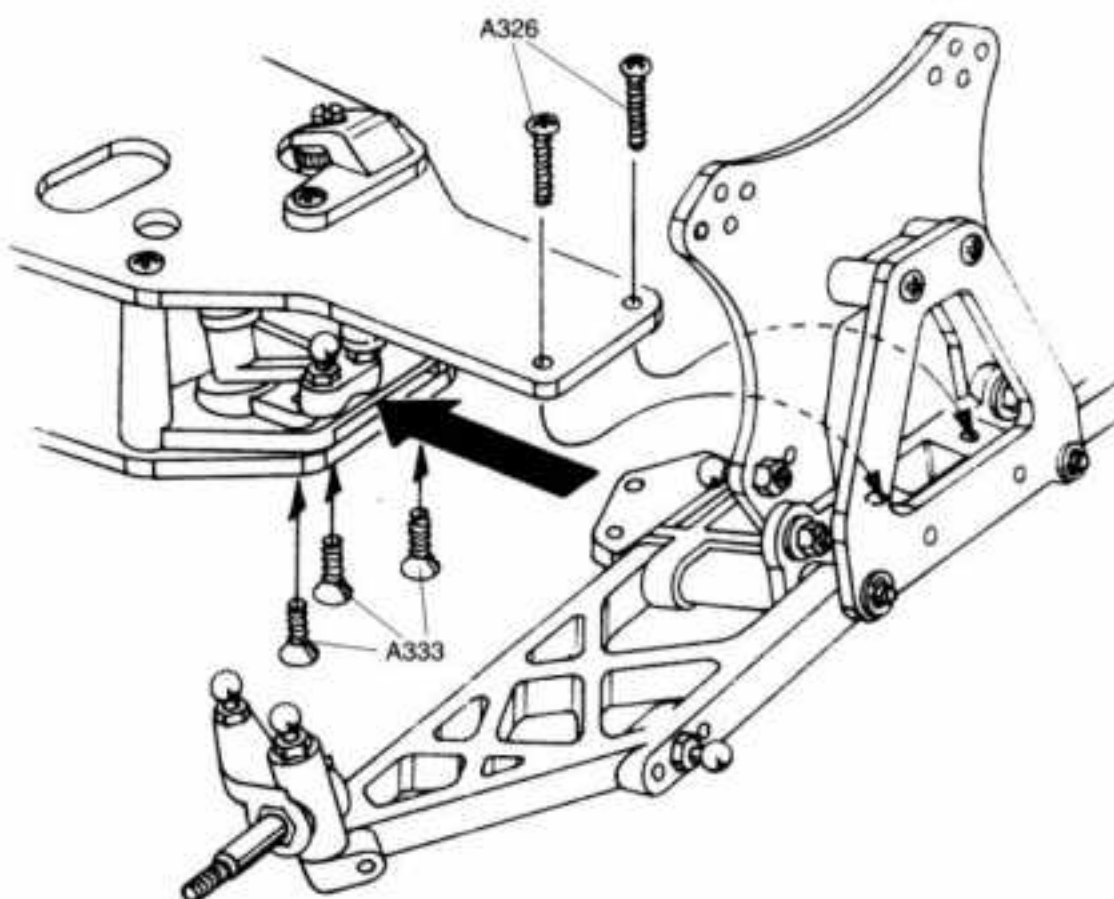

14

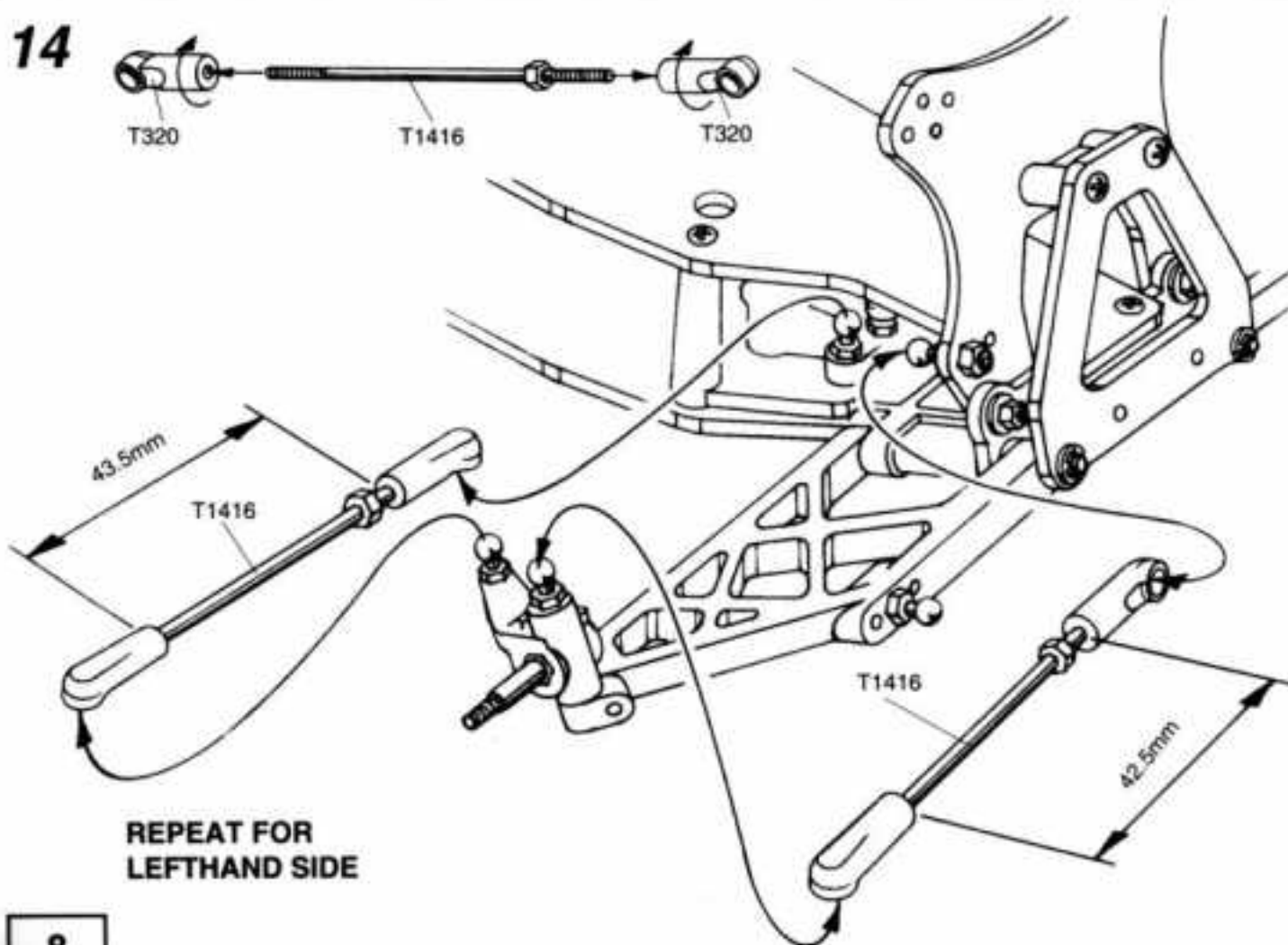

REPEAT FOR  
LEFTHAND SIDE

1

REPEAT FOR  
LEFTHAND  
SIDE

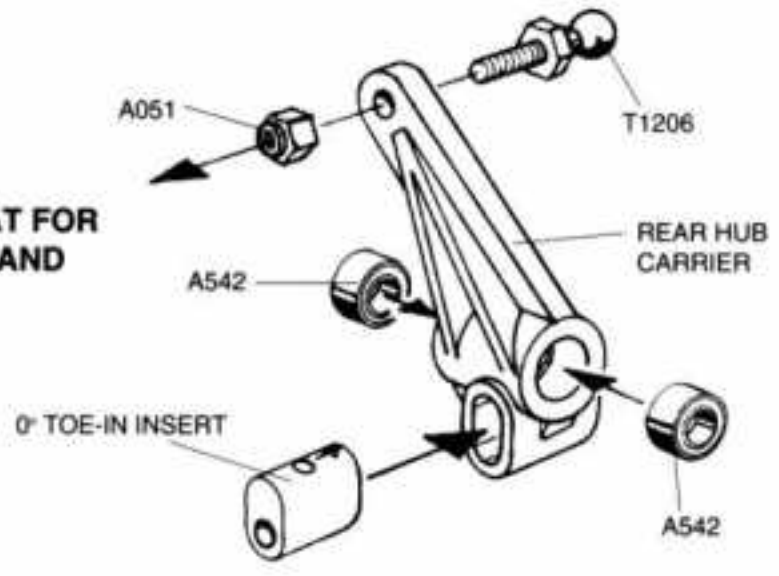

**TOE-IN INSERTS**

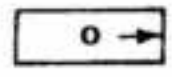

0° INSERT WILL GIVE AN  
ACTUAL TOE-IN OF 3°

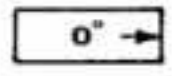

**REAR SUSPENSION**

**HARDWARE**

2

REPEAT FOR LEFTHAND SIDE

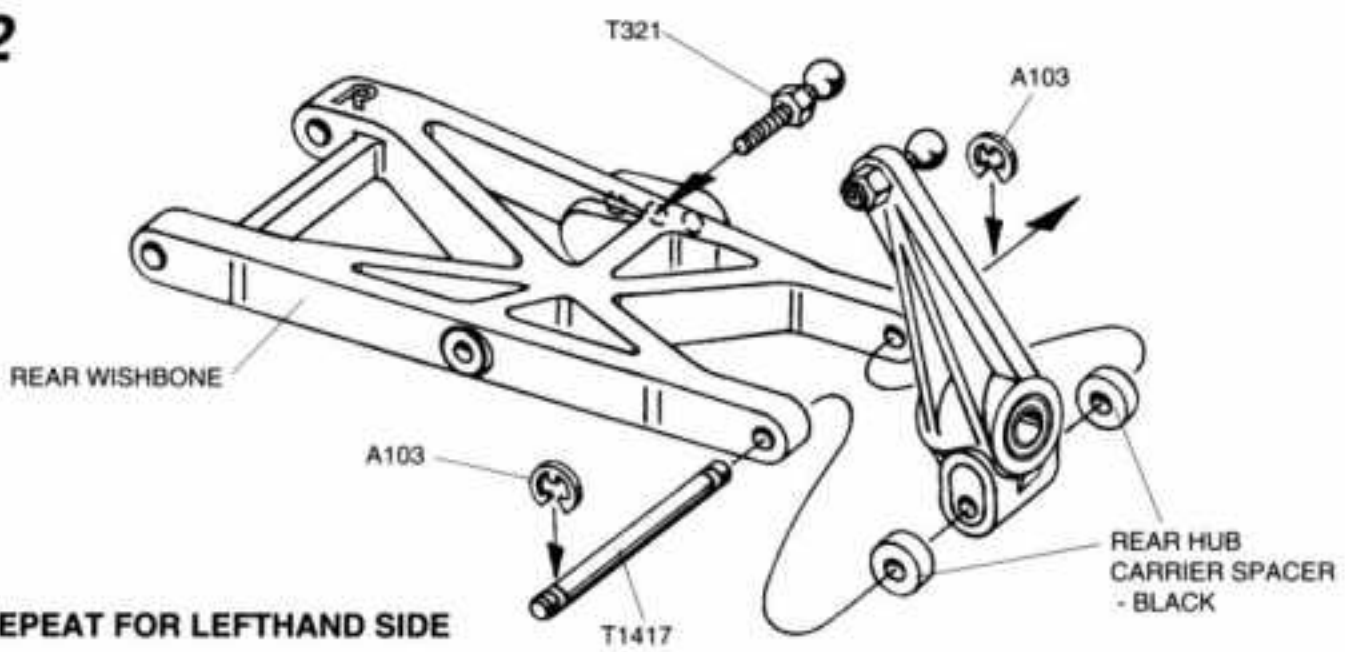

A051 M3 NYLOC NUT  
X2

T1206 BALL STUD LONG  
X2

A524 8x4x3 FLANGED BEARING  
X2

T1417 REAR PIVOT  
PIN - OUTBOARD  
X2

A103 'E' CLIP  
X8

T321 BALL STUD SHORT  
X2

A334 No4x1/2" SELFTAP CSK SCREW  
X2

A333 No4x3/8" SELFTAP CSK SCREW  
X2

A024 M3x16mm CSK SCREW  
X2

T1448 REAR PIVOT  
PIN - INBOARD  
X2

3

4

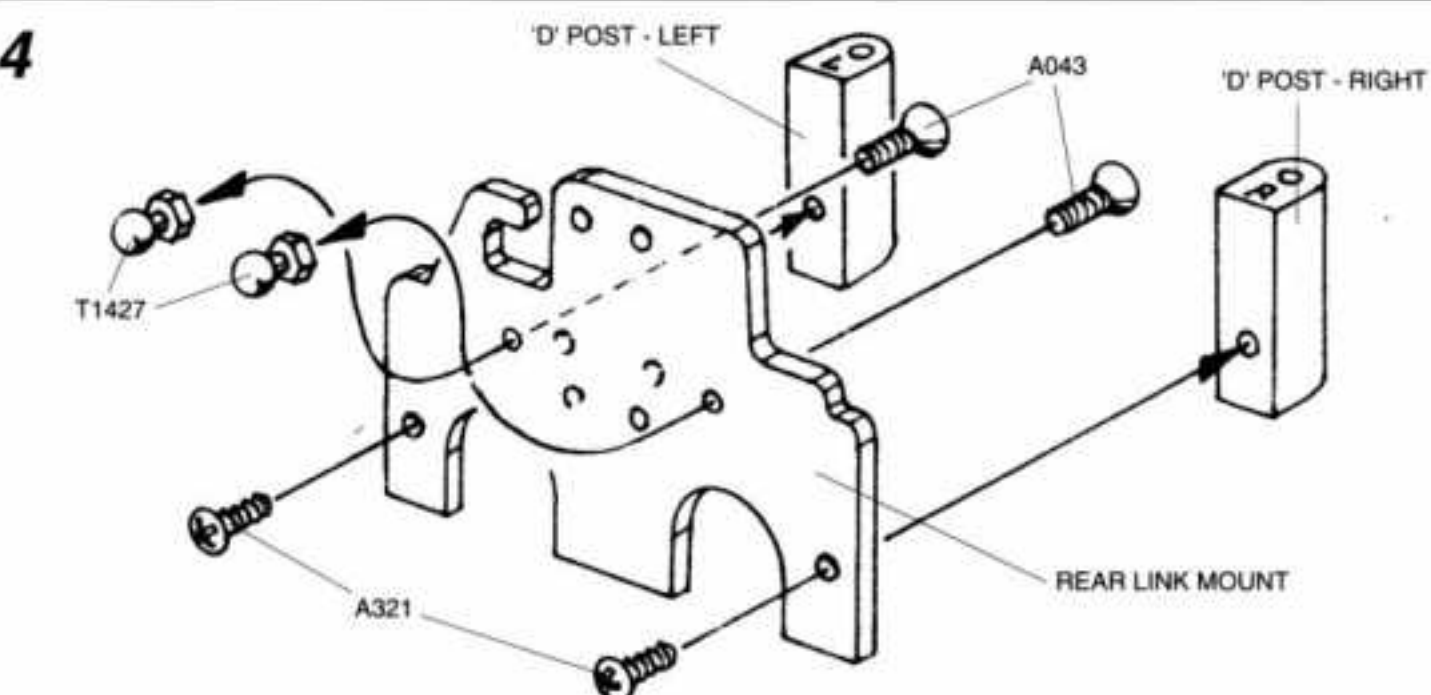
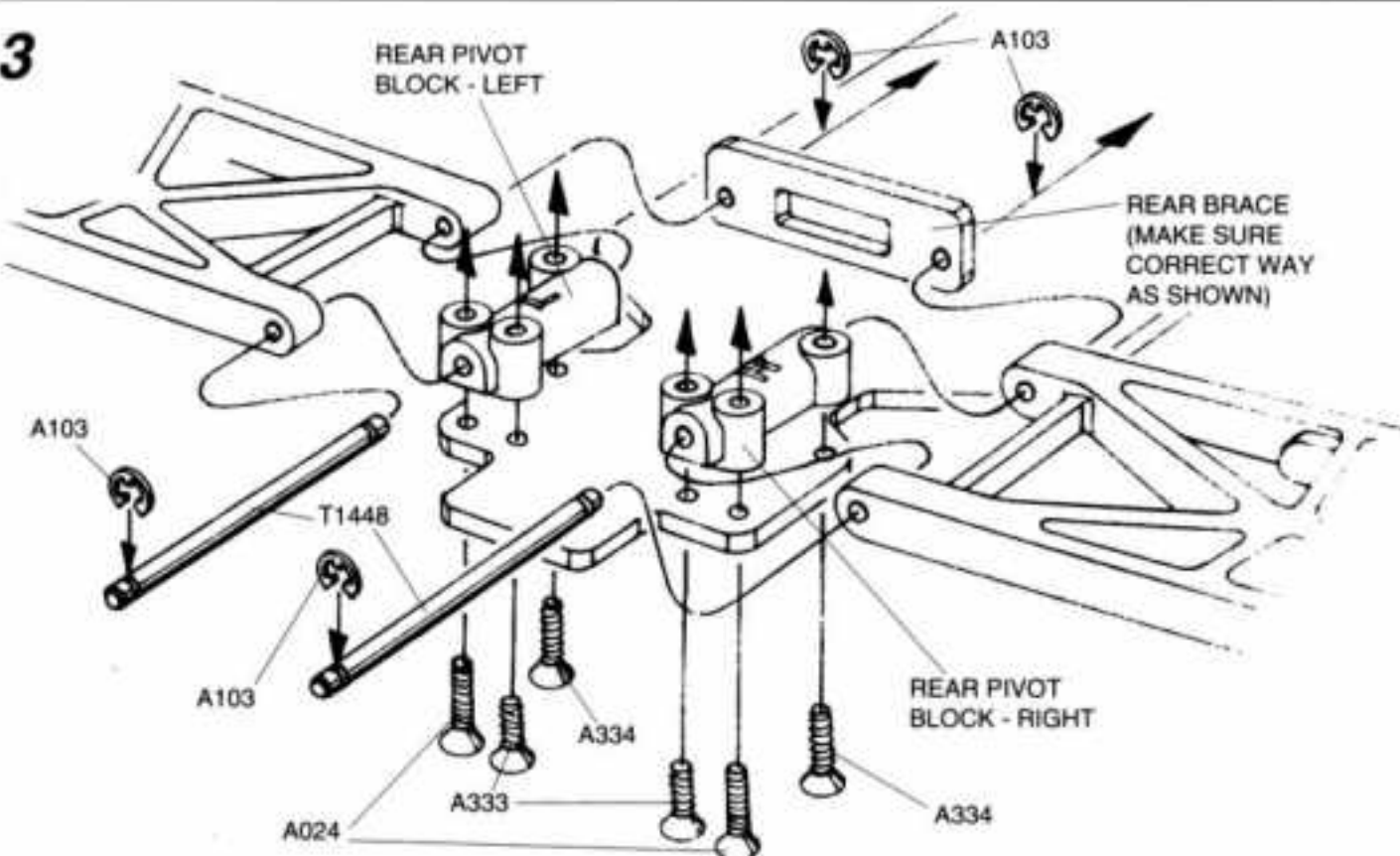

A043 M3x8mm CSK SCREW  
X2

T1427 PIVOT BALL  
X2

A321 No4x1/4" SELFTAP PANHD SCREW  
X2

5

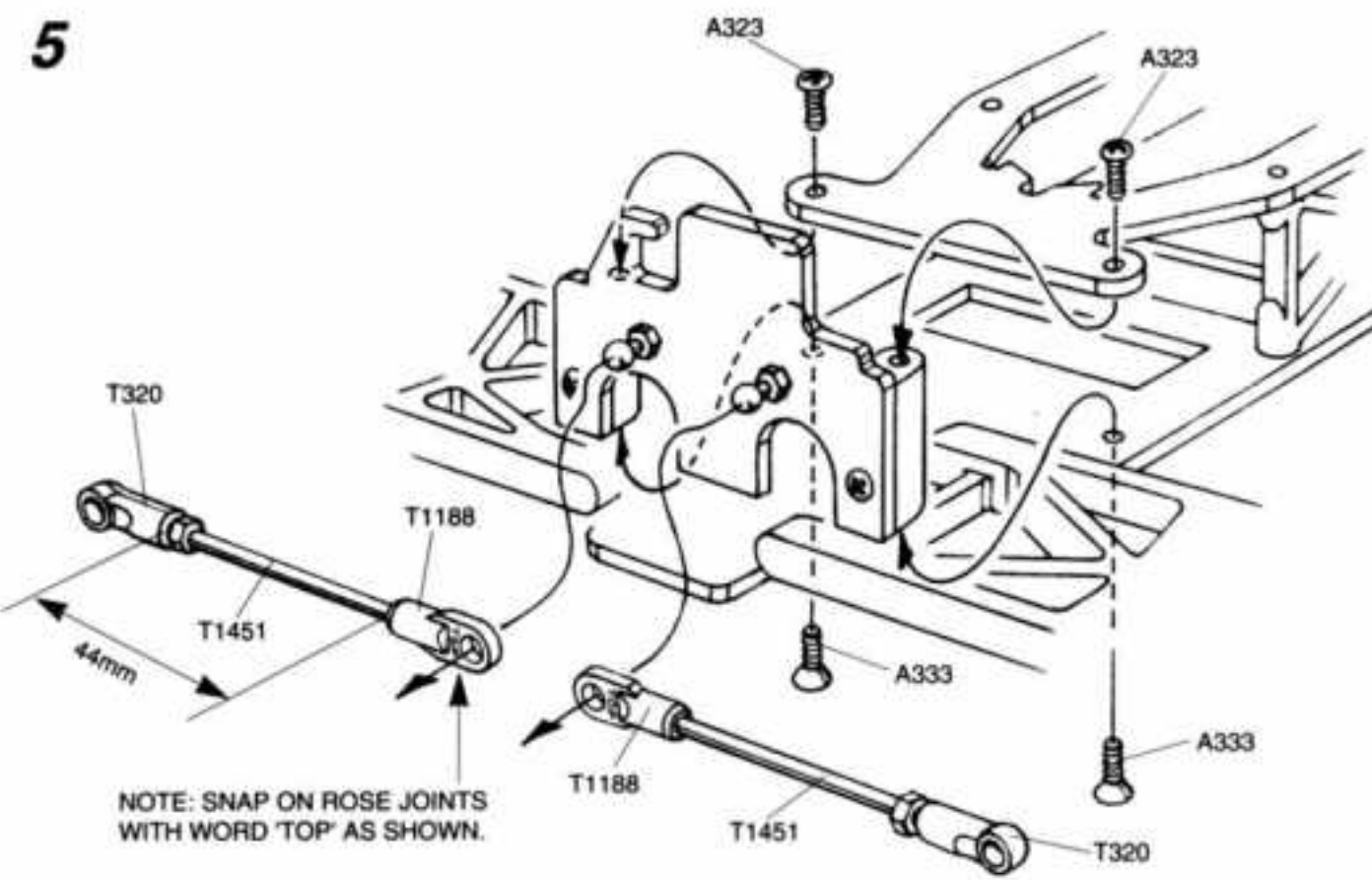

REAR SUSPENSION

HARDWARE

A323 No4x3/8" SELFTAP PANHD SCREW  
X2

A333 No4x3/8" SELFTAP CSK SCREW  
X4

A051 M3 NYLOC NUT  
X2

A324 No4x1/2" SELFTAP PANHD SCREW  
X2

T1416 TURNBUCKLE 60mm  
X2

A030 M3x10mm PANHD SCREW  
X2

A326 No4x3/4" SELFTAP PANHD SCREW  
X2

A048 M3 NUT  
X2

T1188 ROSE JOINT SOCKET - LONG  
X2

6

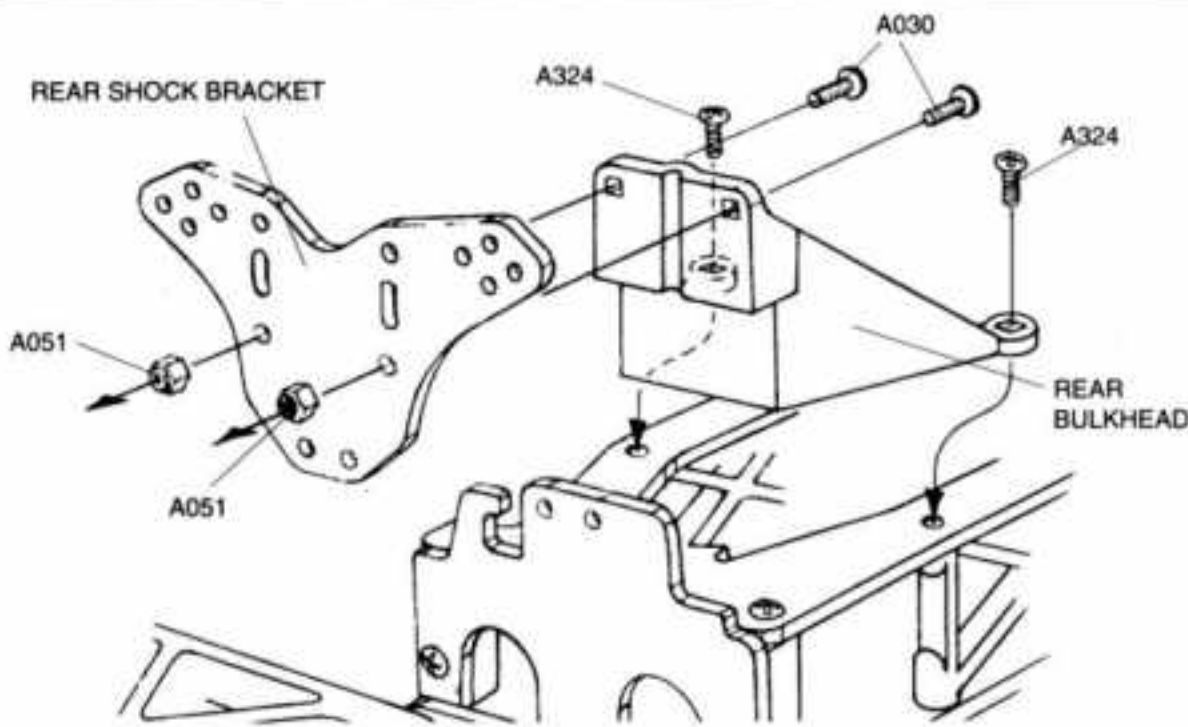

7

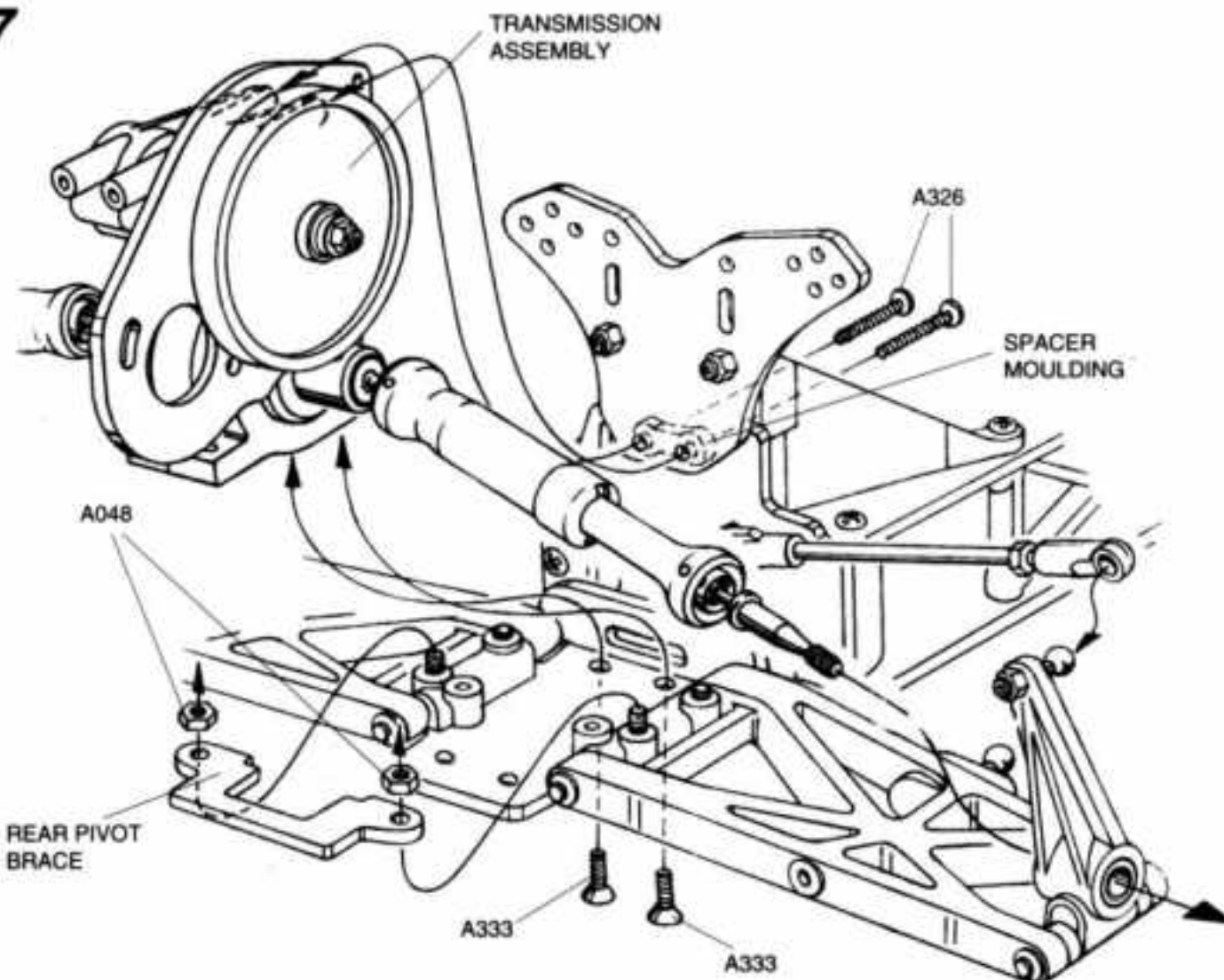

**SHOCK ABSORBERS**

**HARDWARE**

**1**

**REAR X2**

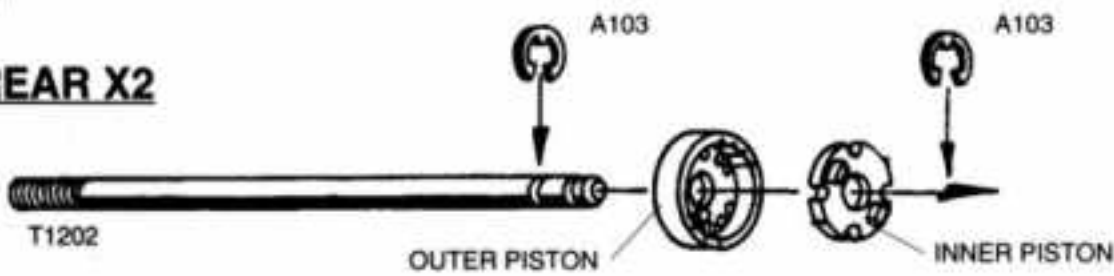

**FRONT X2**

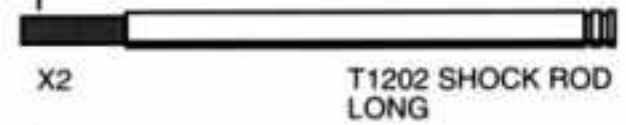
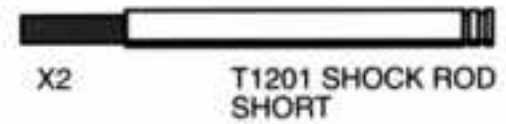
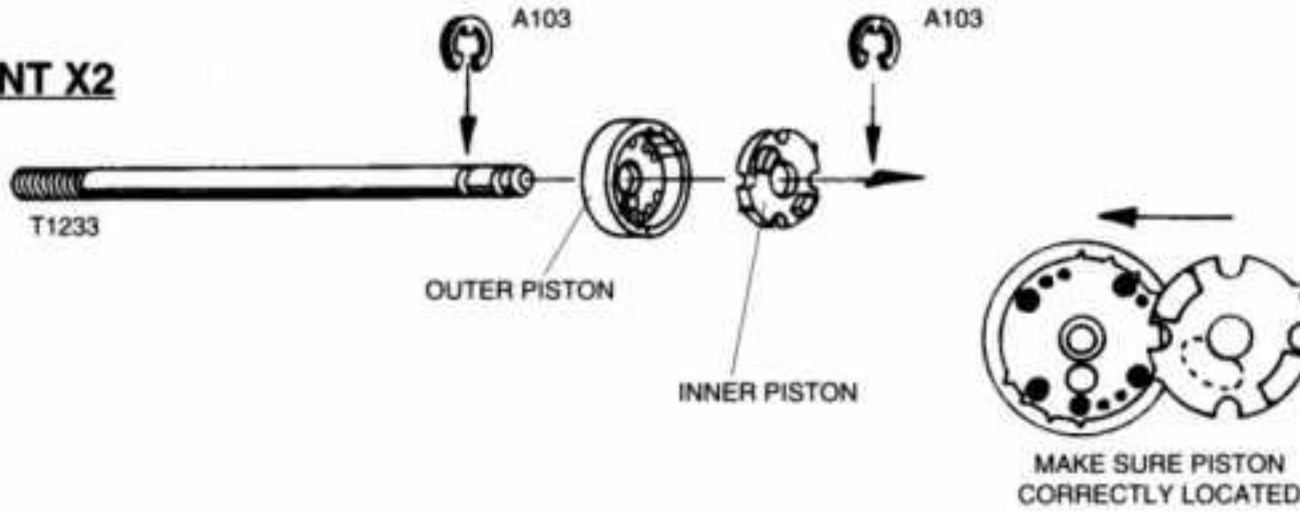

**2**

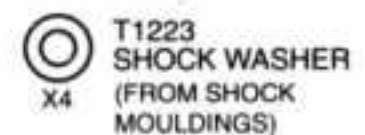
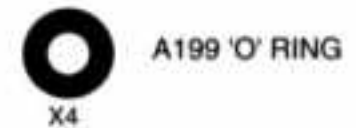
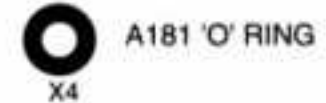
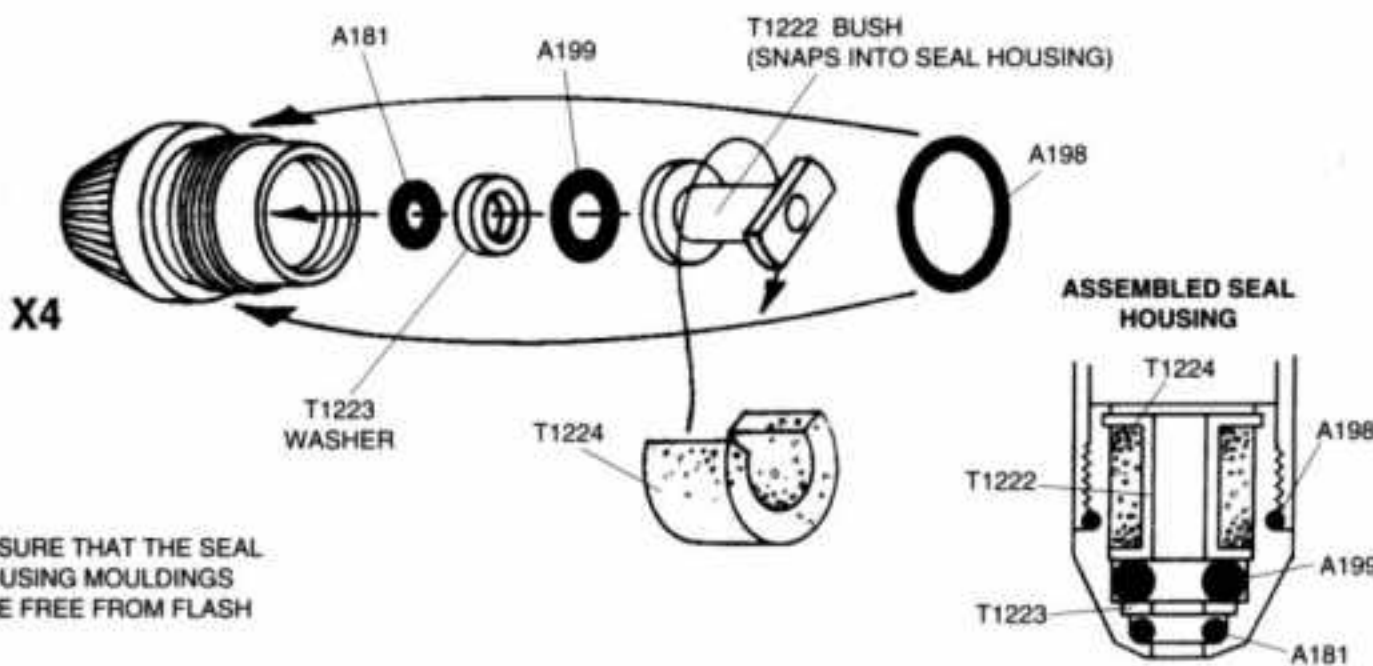

**3**

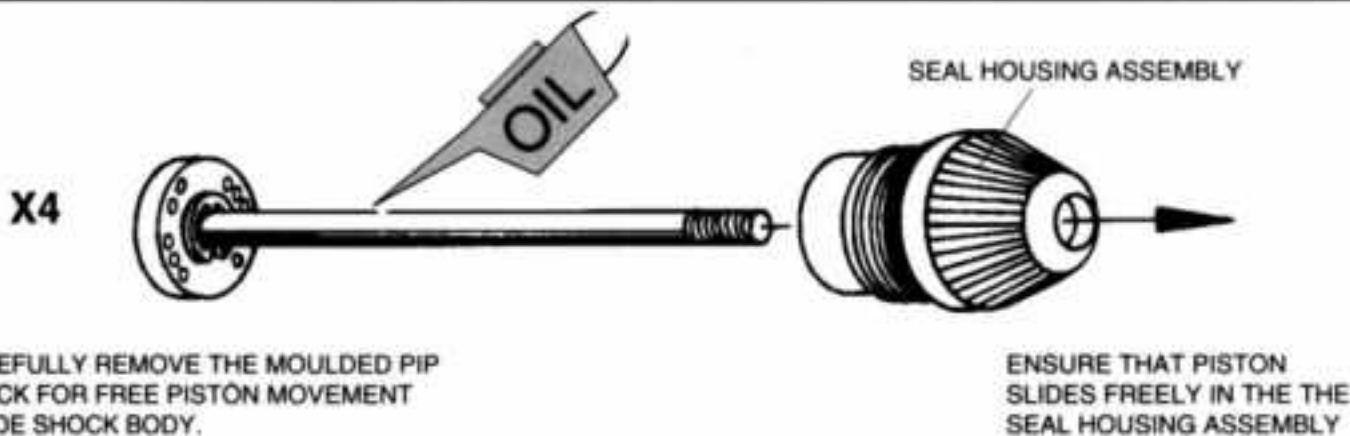

**4**

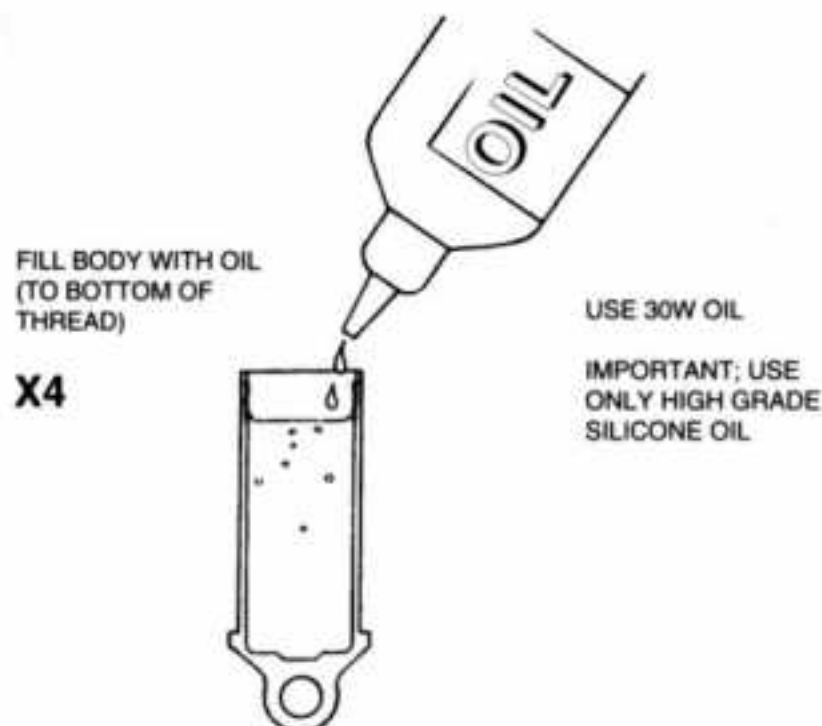

5

DAMPING ADJUSTMENT

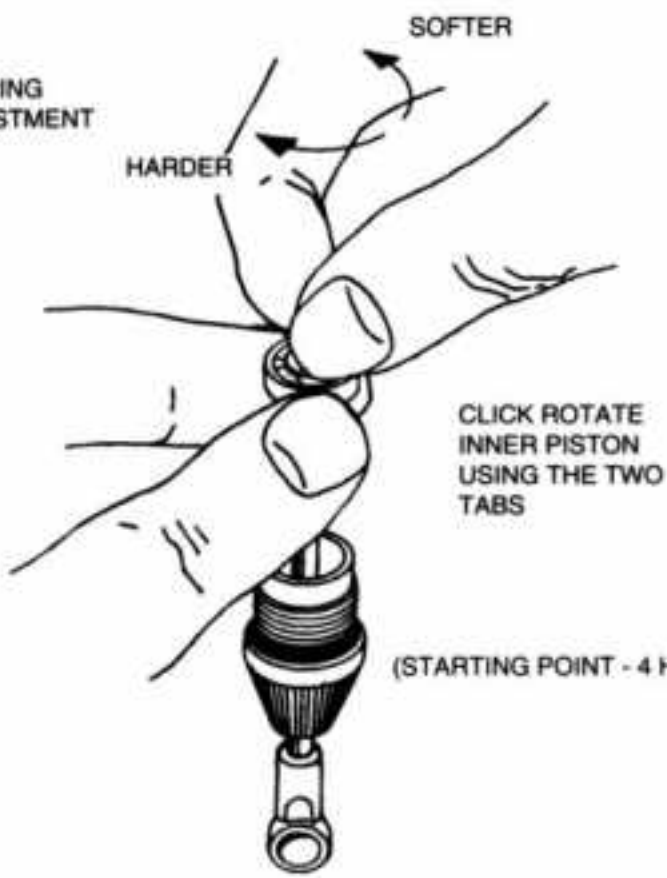

SOFT



4 HOLES OPEN



3 HOLES OPEN



2 HOLES OPEN



1 HOLE OPEN

HARD

Schumacher

COUGAR  
2000

SHOCK ABSORBERS

HARDWARE

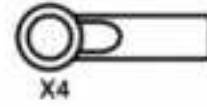

T320  
BALL JOINT SOCKET

X4

6

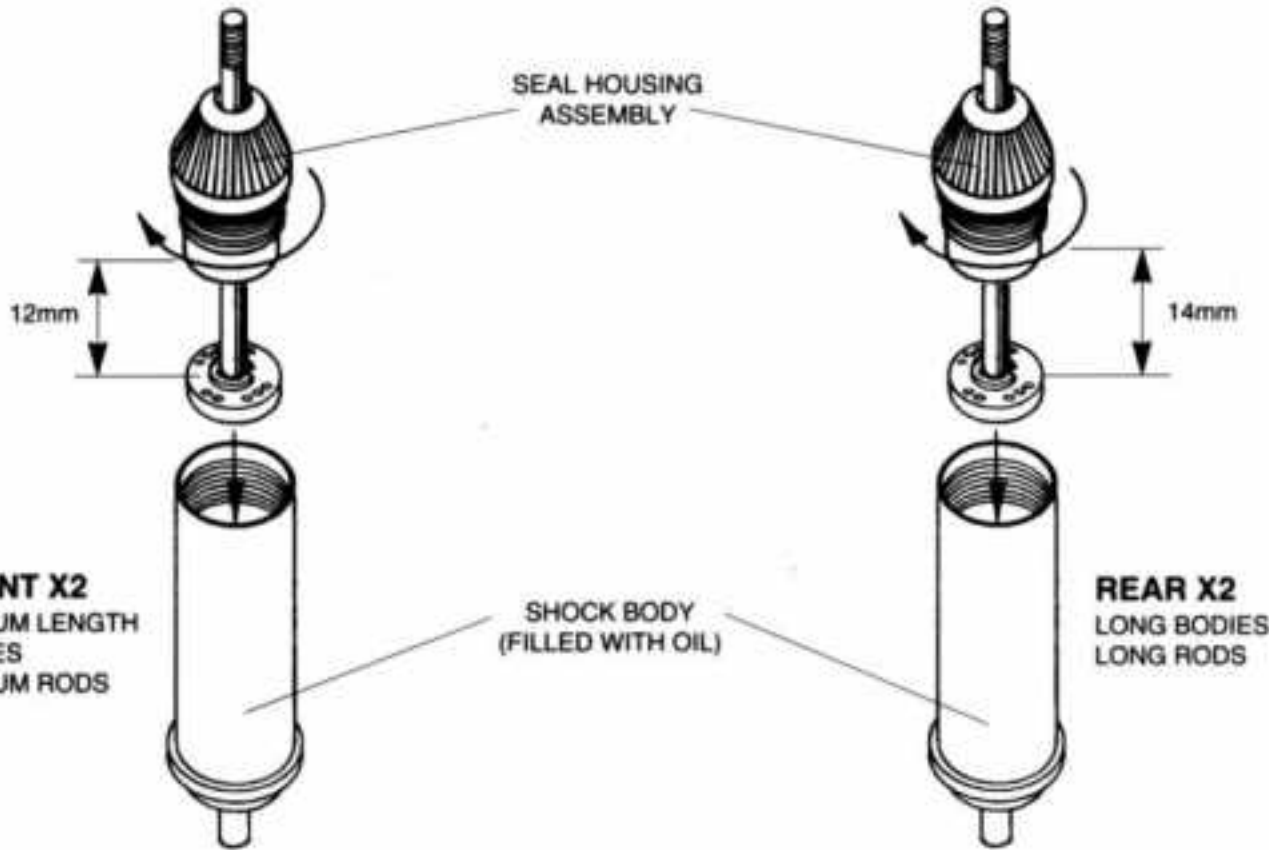

7

NOTE: SEAL HOUSING FULLY SCREWED IN - NO 'O' RING VISIBLE

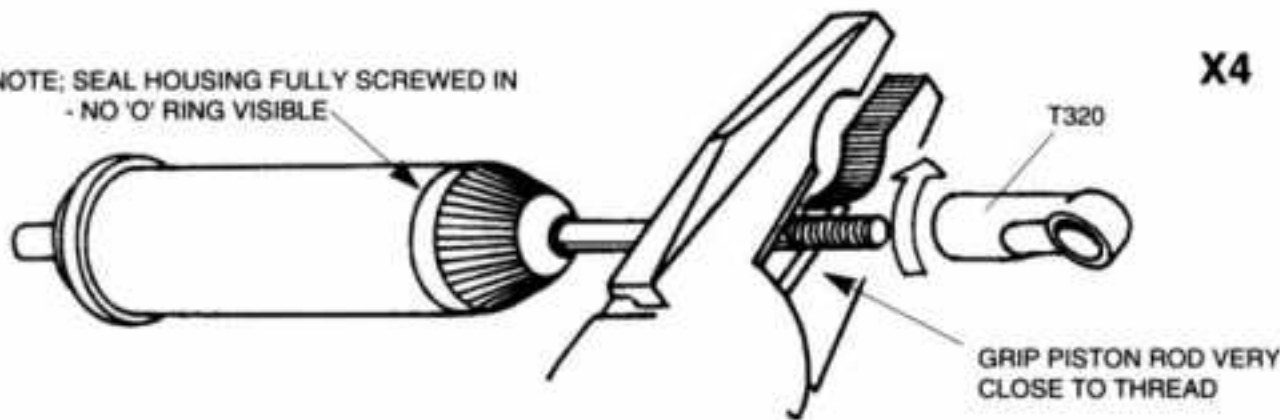

8

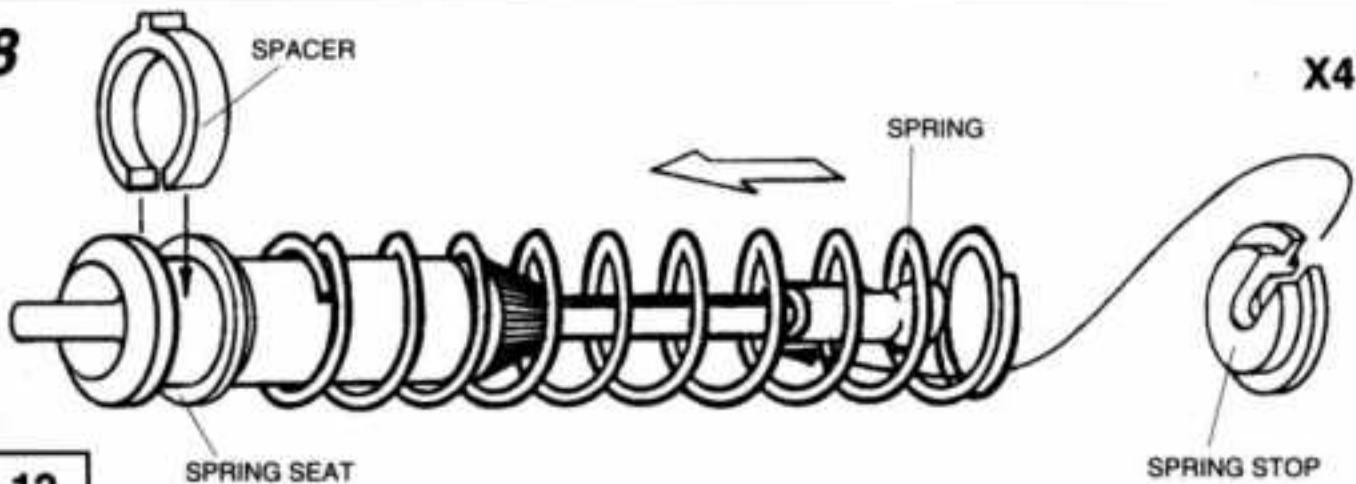

12

**FITTING FRONT SHOCK ABSORBERS**

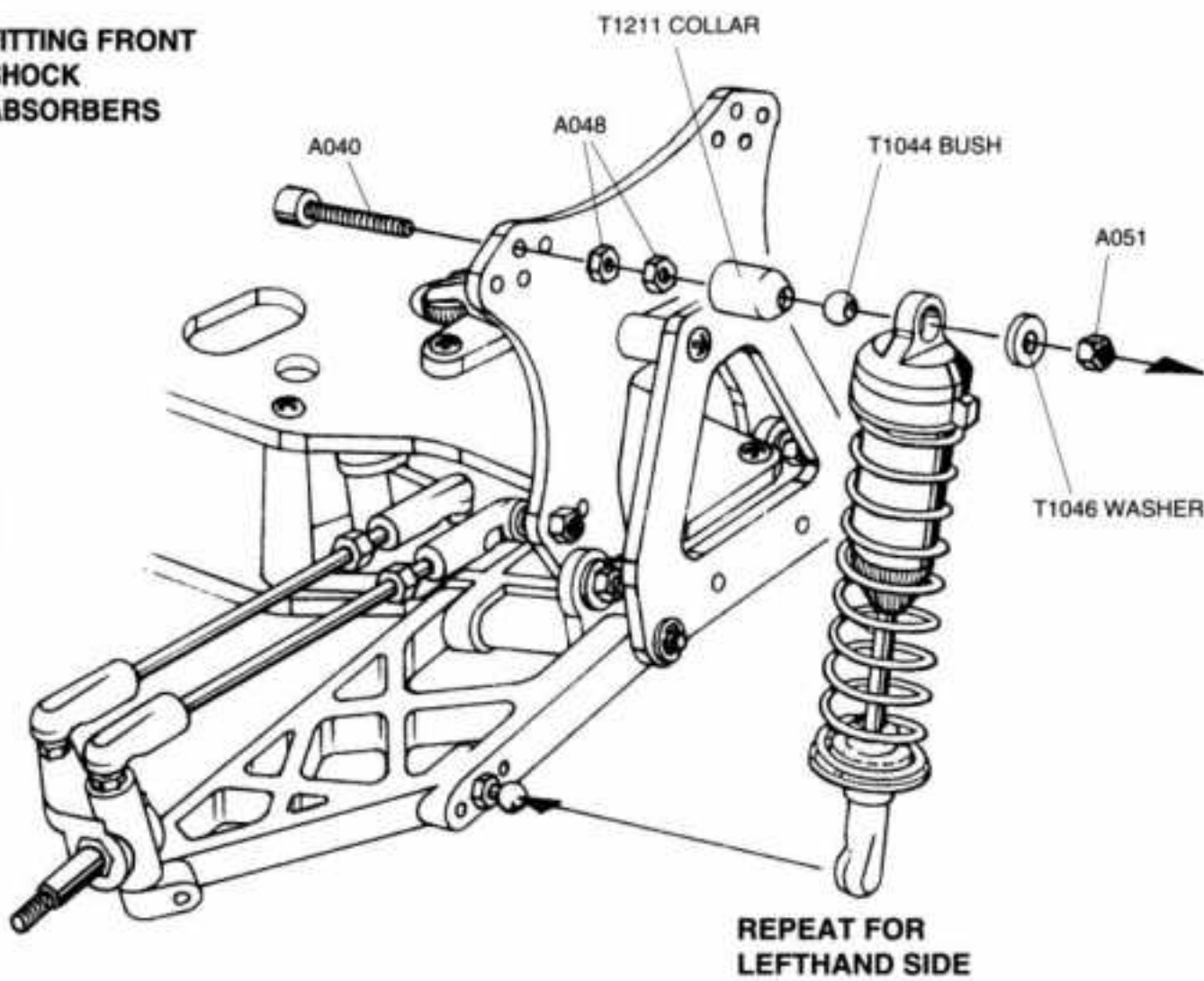



**SHOCK ABSORBERS**

**HARDWARE**

 A040 M3x20mm CAPHEAD SCREW  
X4

 A048 M3 NUT  
X8

 A051 M3 NYLOC NUT  
X4

 T1044 SHOCK SPHERICAL BUSH  
X4

 T1211 SHOCK COLLAR  
X4

 T1046 SHOCK MOUNT WASHER  
X4

**FITTING REAR SHOCK ABSORBERS**

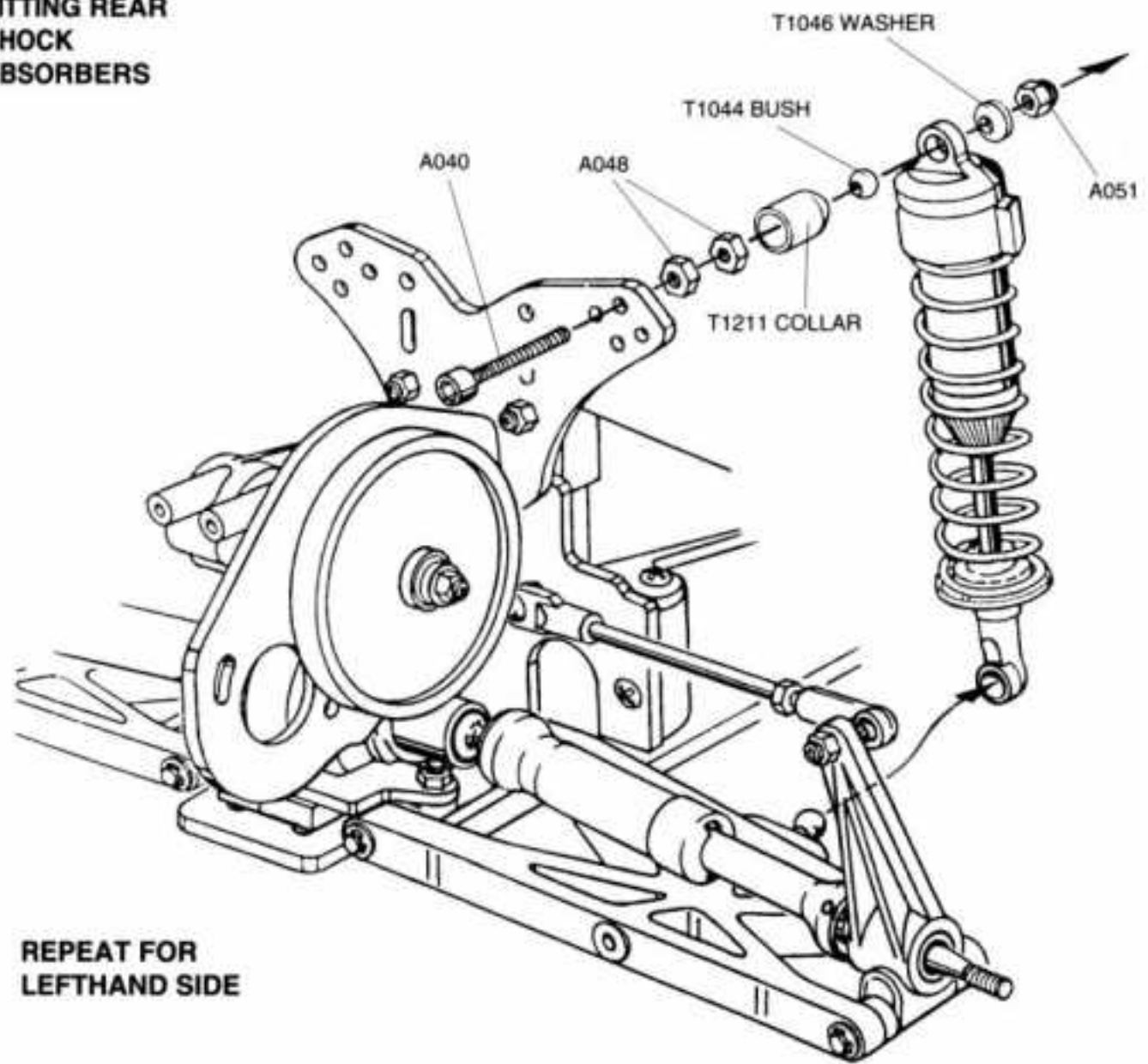

REPEAT FOR LEFTHAND SIDE

SCHUMACHER PARTS LIST - COUGAR 2000/95

QTY REQ	PART NO	DESCRIPTION	QTY REQ	PART NO	DESCRIPTION
		<b>KITS</b>			<b>TRANSMISSION - continued</b>
	<b>U474A</b>	<b>COUGAR 2000/95 Spec - 2WD Off Road BODY &amp; CHASSIS</b>		U1505S	Washer Carrier, female, Co-Ax U/J - C2000
	U119J	Aerial Tube		U1506T	Diff Bushings 4 x 8 x 2mm - C2000 (pr)
	U122M	Velcro 1/2metre x 10mm.		U1507U	Diff Thrust Bearing - C2000
	U1403U	Wing & Side Plates - OFF ROAD		U1508V	Inboard Co-Ax U/J - C2000 (each)
	U1406X	Chassis Gates - C2000 (pk 5)		U1510X	Rear Axle Co-Ax U/J - C2000 (each)
	U1407Y	Nicad Strap - C2000		U1511Y	Driveshafts, Co-Ax U/J - C2000 (pr)
	U1456V	Front & Rear Bumper - 2000/2WD (pr)		U1526N	Diff Nut Lock - Cat 2000
	U1461A	Flourescent Decal Sheet - C2000		U1571G	18mm Diff, Assembled-C2000/94
	U1694A	XPC Chassis, Lower - Cougar 2000		U1615Y	Rear Wheels 3 Spoke CAT 2000
	U1695B	XPC Chassis, Upper - Cougar 2000		U1616Z	Front Wheels 3 Spoke Cougar 2000
	U1723D	Lexan Radio Mounts - Cougar 2000/95		U730D	Thrust Bearing 1/8" x 5/16"
	U1724E	Instruction Book - Cougar 2000/95		U855Y	Thrust Plate & Drive Hub - Slipper
	U253J	Servo Mounts - Lay Down (pr)		U856Z	Repair Kit - Q C Slipper
	U5045V	Bodyshell - Cougar 2000/95			<b>SHOCK ABSORBERS</b>
	U5046W	Undertray - Cougar 2000/95		U1202B	Piston Rod - Long Shock (pr)
	U832B	Wing Mount Kit		U1258F	Piston Rod, Short Shock (pr)
		<b>SUSPENSION</b>		U1310F	Shock Mouldings-Vari Click Piston (pr)
	U1425Q	Pivot Pin-Rear Inner-C2000 2WD (pr)		U1351U	Short Spring Tuning Set-Colour (4prs)
	U1426R	Pivot Pin-Rear Outer-C2000 2&4 (pr)		U1353W	Long Spring Tuning Set-Colour (4prs)
	U1427S	Turnbuckle 540unc x 65mm (pr)		U1356Z	Pro-Shock Absorbers - Short (pr)
	U1428T	Turnbuckle 540unc x 60mm (pr)		U1358B	Pro-Shock Absorbers - Long (pr)
	U1431W	Rear Hub Carrier & Inserts-C2000 (pr)		U1359C	Pro-Shock Body - Short (each)
	U1432X	Toe In Inserts - Rear C2000 (3prs)		U1361E	Pro-Shock Body - Long each
	U1433Y	Rear Wishbone - Cougar 2000 (pr)		U1362F	Pro-Shock Seal Pack (pr)
	U1434Z	Rear Pivot Block-C2000 2 & 4WD (pr)		U613J	Spring Stop & Spacer Mouldings (pr)
	U1437C	Rear Pivot Straps, WFE - C2000 (pr)			<b>SPEED SECRETS - OPTION PARTS</b>
	U1438D	Rear Bulkhead Moulding - C2000		U1195V	98T Q.C. Slipper Gear - 48 D.P.
	U1439E	Ball Bearing 5 x 9 x 3mm (pr)		U1248V	Ballbearings - C2000 Steering (pk 2)
	U1442H	Pivot Pin - Front Inner (pr)		U1261I	Pozi Screw Driver No1
	U1443I	Servo Link - Cougar 2000		U1419K	Diff Ball Bearing 4 x 8 x 2mm (pr)
	U1444J	Bush 1/8 x 1/4" (pk 4)		U1467G	C/F Front Shock Brace - C2000
	U1445K	Steering Posts & Washer - C2000		U1472L	Rear Anti Roll Bar - C2000
	U1446L	Servo Saver - C2000		U1475O	Tungsten Carbide Diff Balls 4mm(pk10)
	U1449O	Steering Levers - Cougar2000 (pr)		U1476P	Tungsten Carbide Balls 1/16" (pk8)
	U1450P	Track Rod & Servo Horns		U1534V	Dual Rate Shock Pistons (2prs)
	U1451Q	Front Suspension Plate - C2000		U1574J	Titanium Turnbuckle 60mm (pr)
	U1452R	Front Bulkhead - C2000		U1575K	Titanium Turnbuckle 65mm (pr)
	U1455U	Front Shock Brace, WFE - C2000		U1577M	Titanium Pivot Pin 29mm (pr)
	U1712S	Active Caster System - SACS-2		U1578N	Titanium Pivot Pin 42mm (pr)
	U1713T	Swept Front Wishbones - SACS-2		U1579O	Titanium Pivot Pin 44mm (pr)
	U1714U	Pivot Pin & Block Set - SACS-2		U1607Q	Alloy Idler Gear - C2000/2WD
	U1715V	Front Axles - SACS-2 (pr)		U1719Z	C/F Short Shock Mount - SACS-2
	U1716W	Steering Blocks - SACS-2 (pr)		U1720A	C/F XPC Chassis, Lower - Cougar 2000
	U1717X	Pivot Blocks - SACS (pk4)		U1721B	C/F XPC Chassis, Upper - Cougar 2000
	U1718Y	Short Front Shock Mnt, WFE - SACS-2		U1727H	Hydradrive Layshaft & Cover - Cgr2000
	U1722C	Rear Top Link Mnt, WFE - Cgr2000/95		U233P	19T PINION - 48 D.P. 1
	U1728I	Rear Shock Mnt, WFE - Cgr 2000/95		U234Q	22T PINION - 48 D.P.
	U1729J	C/F Rear Shock Mount - Cgr 2000/95		U235R	25T PINION - 48 D.P.
	U750X	Ball Joint - Short Ball Stud (8prs)		U236S	28T PINION - 48 D.P.
	U822R	Rose Joints M3 - Long pk4		U324G	95T QC Slipper Gear - 48 DP
	U851U	Ball Joints - Long Ball Stud (8prs)		U325H	92T QC Slipper Gear - 48 DP
		<b>TRANSMISSION</b>		U326I	89T QC Slipper Gear - 48 DP
	U1301W	Silicone Diff Grease - Tube		U327J	86T QC Slipper Gear - 48 DP
	U1408Z	Hex Wheel Drive - C2000 2&4 (pr)		U5041R	Flex-Wing - Moulded WHITE
	U1409A	Wheel Nuts - C2000/2wd (4 sets)			<b>SPEED PACKS - HARDWARE</b>
	U1410B	Ball Bearing - 10 x 15 x 4 (pr)		U1247U	SPEED PACK - Wing Mount 'O' Ring
	U1411C	Ball Bearing - 4 x 8 x 3 Non Fl. (pr)		U1538Z	SPEED PACK - Long Self Tap Pan
	U1412D	Idler Shaft - C2000/2wd		U1539A	SPEED PACK - Self Tap Csk Hd
	U1414F	Slipper Layshaft - C2000/2wd		U1540B	SPEED PACK - Short M3 Pan Hd
	U1415G	Diff Washer - 18mm C2000 (pr)		U1542D	SPEED PACK - Long M3 Pan Hd
	U1417I	Diff Screw, Springs&Spacer - C2000		U1543E	SPEED PACK - M3 Csk Hd
	U1420L	Diff Balls 4mm - Carbon Chrome (pk10)		U1544F	SPEED PACK - Short M3, Cap Hd
	U1421M	Transmission Housing Set - C2000/2WD		U1547I	SPEED PACK - M3 Nuts
	U1422N	Diff & Lay Gear Moulding - C2000		U1548J	SPEED PACK - M3 Washers
	U1423O	Idler Gear Mouldings - C2000		U1550L	SPEED PACK - Socket Wrenches (pk3)
	U1424P	Motor Plate - Cougar 2000		U1551M	SPEED PACK - *E* Clips 1/8" (pk8)
	U1459Y	Gear Cover & Bung - Cougar2000		U1552N	SPEED PACK - *R* Clips (pk4)
	U1504R	Washer Carrier, male, Co-Ax U/J-C2000		U1633Q	SPEED PACK - Needle Rollers (pk)



# COUGAR 2000

THIS DIAGRAM SHOWS HOW TO ORDER YOUR SPARES  
ALTERNATIVES MAY BE FOUND IN THE SPARES LIST

- |        |   |
|--------|---|
| U750X  | BALL JOINTS-SHORT BALL STUD & SKT (8prs)      |
| U851U  | BALL JOINTS-LONG BALL STUD & SKT (8prs)       |
| U1248V | BALLBEARING 1/8" x 1/4" (pr) -STEERING LEVERS |
| U1443I | SERVO SAVER LINK                              |
| U1459Y | GEAR COVER & BUNG - C2000                     |

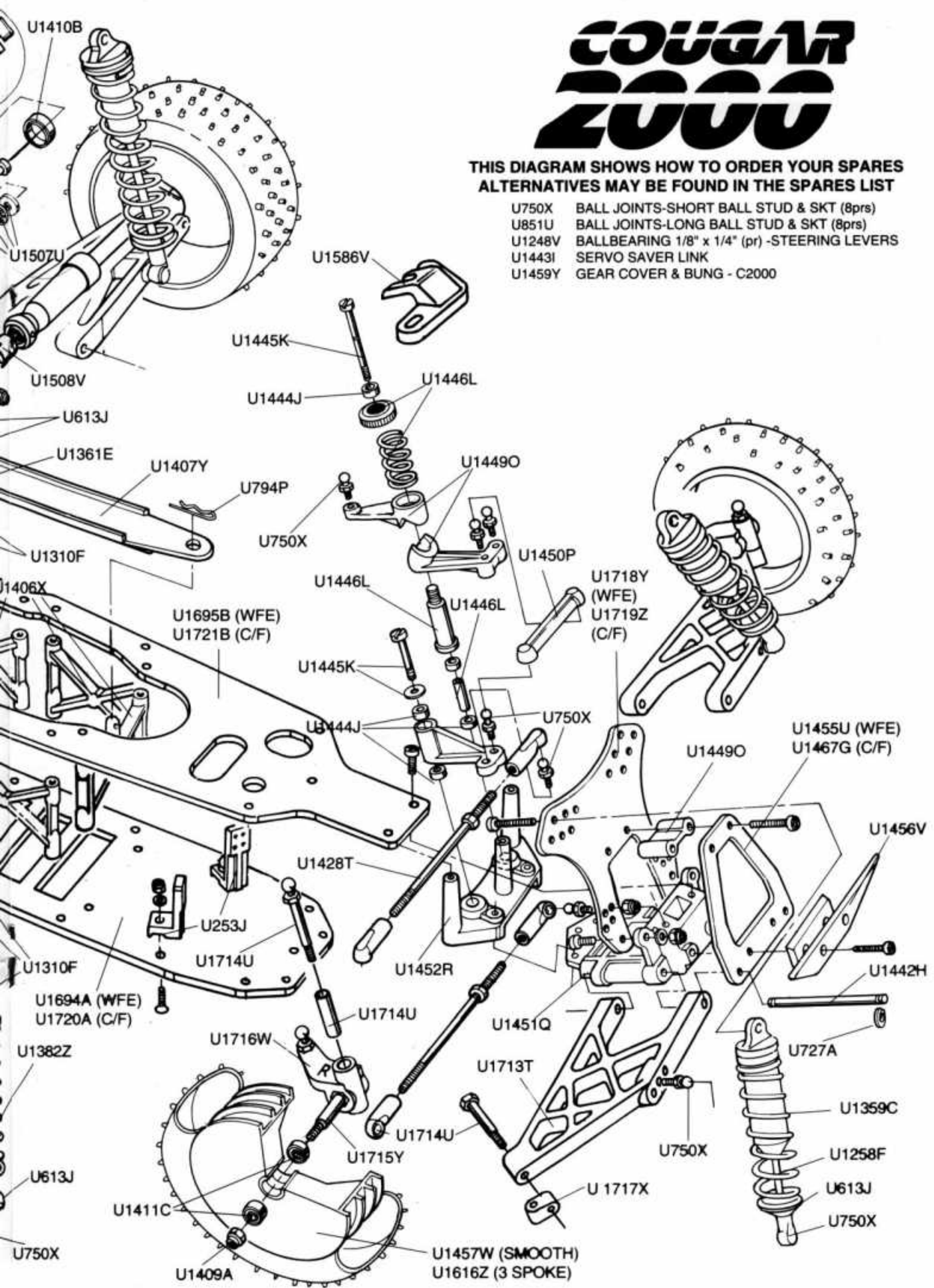

## 2.2" OFF ROAD TYRES

TYRE COMPOUND →	BIBX			GREEN		BLUE		YELLOW		PRICE
	QTY	PART No	PRICE	QTY	PART No	QTY	PART No	QTY	PART No	
2.2" Front 8x20 Mini Spike		<b>U6566I</b>			U6515J		U6517L		U6557Z	
2.2" Rear 12x20 Mini Spike		<b>U6565H</b>			U6516K		U6518M		U6558A	
2.2" Front 2x20 Stud					U6524S		U6523R			
2.2" Rear 8x10 Full Spike					U6528W		U6527V			
2.2" Front 6x10 Full Spike					U6530Y		U6529X			
2.2" Rear 8x10 Cut Spike		<b>U6582Y</b>			U6532A		U6531Z			
2.2" Front 6x10 Cut Spike		<b>U6583Z</b>			U6534C		U6533B			
2.2" Rear 22x34 Micro Spike		<b>U6567J</b>			U6536E		U6535D			
2.2" Front 14x 34 Micro Spike		<b>U6568K</b>			U6538G		U6537F			
2.2" Rear 6x 20 Full Spike		<b>U6584A</b>			U6545N		U6544M			
2.2" Hi Profile Rear Mini Spike		<b>U6561D</b>					<b>U6562E</b>			
2.2" Hi Profile Front Mini Spike		<b>U6563F</b>					<b>U6564G</b>			

## CAT ORIGINALS

TYRE COMPOUND →	BIBX			GREEN		BLUE		YELLOW		PRICE
	QTY	PART No	PRICE	QTY	PART No	QTY	PART No	QTY	PART No	
CAT Rear 4x20 Full Spike					U6514I		T687E		T650T	
CAT Front 3x 20 Full Spike					U6513H		T688F		T652V	
CAT Rear 15x12 Mini Spike					U6512G		T679W			
CAT Front 11x12 Mini Spike					U6511F		T681Y			
CAT Front 2x20 Stud		<b>U6574Q</b>			U6519N		T689G			
CAT Rear 5x24 Mini Spike							T690H			
CAT Front 4x24 Mini Spike							T691I			
CAT Rear 6x20 Block							T692J			
CAT Front 4x20 Block							T693K			
CAT Rear 6x20 Cut Spike							T694L			
CAT Front 1+20 Rib Spike							T695M			
CAT Front Rib		<b>U6575R</b>			U65460					

## SLIMS

TYRE COMPOUND →	BIBX			GREEN		BLUE		YELLOW		PRICE
	QTY	PART No	PRICE	QTY	PART No	QTY	PART No	QTY	PART No	
Slim 2WD Front - Stagger rib		<b>U6569L</b>			U6548Q		U6547P			
Slim 2WD Front - Mini Spike		<b>U6570M</b>			U6550S		U6549R		<b>U6581X</b>	

## TRUCK

TYRE COMPOUND →	BIBX			GREEN		BLUE		YELLOW		PRICE
	QTY	PART No	PRICE	QTY	PART No	QTY	PART No	QTY	PART No	
Truck Racing VEE2		<b>U6576S</b>					U6502W			
Truck Racing VEE4		<b>U6577T</b>					U6503X			
Truck 20x15 Mini Spike		<b>U6578U</b>			U6520O		U6508C			
Truck 6x24 Stagger Rib		<b>U6579V</b>			U6526U		U6525T			
Truck 26x39 Micro Spike		<b>6580W</b>					U6542K			

## ON ROAD

QTY	PART No	DESCRIPTION	PRICE
	U6500U	Road & Track - RT1 Front	
	U6501V	Road & Truck - RT1 Rear	
	U6509D	Road & Track - RT2 Front	
	U6510E	Road & Track - RT2 Rear	
	<b>U65720</b>	<b>Road &amp; Track - RT2 Front Green</b>	
	<b>U6573P</b>	<b>Road &amp; Track - RT2 Rear Green</b>	
	U6553V	"Sponges" - 2.2" Aerodisc Rear	
	U6554W	"Sponges" - 2.2" Aerodisc Front	
	U6555X	"Sponges" - Slim - Front	
	U6556Y	"Sponges" - Truck	
	U6559B	"Sponges" - C2000 Rear 2 & 4wd	
	U6560C	"Sponges" - Cougar 2000 Front 2wd	
	<b>U6571N</b>	<b>"Sponges" - CAT 2000 Front 4wd</b>	
		All "Sponges" are trued & glued on wheels	

## FOAM TYRE INSERTS

QTY	PART No	DESCRIPTION	PRICE
	U6539H	CAT Foam Inserts - Front	
	U6540I	CAT Foam Inserts - Rear	
	U6541J	CAT Foam Inserts - Truck	

## WHEELS

	U1089R	Truck Wheel 2.2" (Fr&Rr)-Natural	
	U396A	Truck Wheel 2.2" (Fr&Rr)-Yellow	
	U224G	Front Wheel-Spoked White - (pr)	
	U225H	Rear Wheel-Spoked White - (pr)	
	U1147X	Aerodisc Rear Wheel - 2.2"	
	U1148Y	Aerodisc Front Wheel - 2.2"	
	U1228B	Slim Front Wheel - White (pr)	
	U1457W	Front Wheel - 2.1" Cougar 2000	
	U1458X	Rear Wheel 2.2" C2000 2 & 4 wd	
	U1516D	Front Wheel 2.2" CAT 2000	

- BIBX** - New compound specially formulated for superb grip on hard clay tracks. **2nd & 3rd WORLDS!!!**  
**GREEN** - Soft natural compound with high level of grip and natural damping.  
**BLUE** - Natural compound for high traction tracks.  
**YELLOW** - Special compound for indoor racing on polished floors.

**BOLD = NEW**

**1 FITTING TYRES TO WHEELS**  
 MAKE SURE TYRE BEAD SEATS PROPERLY IN GROOVES OF WHEEL  
 THE WHEELS CAN BE DYED ANY COLOUR AVAILABLE.

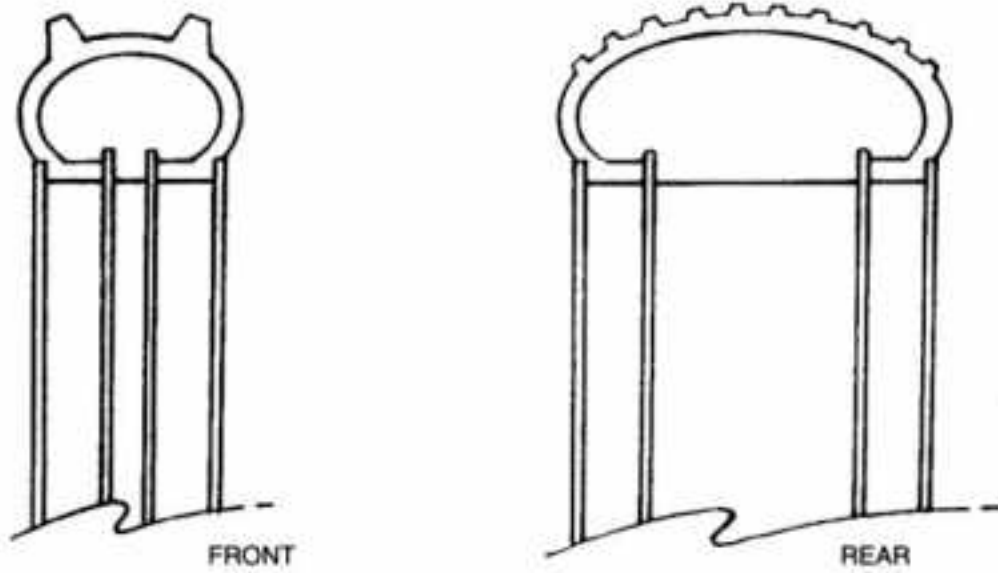

 **A540**  
 BALL BEARING 4x8x3mm  
 X4

 **A051** M3 NYLOC NUT  
 X2

 **A228**  
 M4 STEEL WASHER  
 X2

 **A079** M4 NYLOC NUT  
 X2

 **T1406**  
 NARROW TRACK  
 DRIVE PLATE  
 - HEX  
 X2

**2 FITTING FRONT WHEELS**

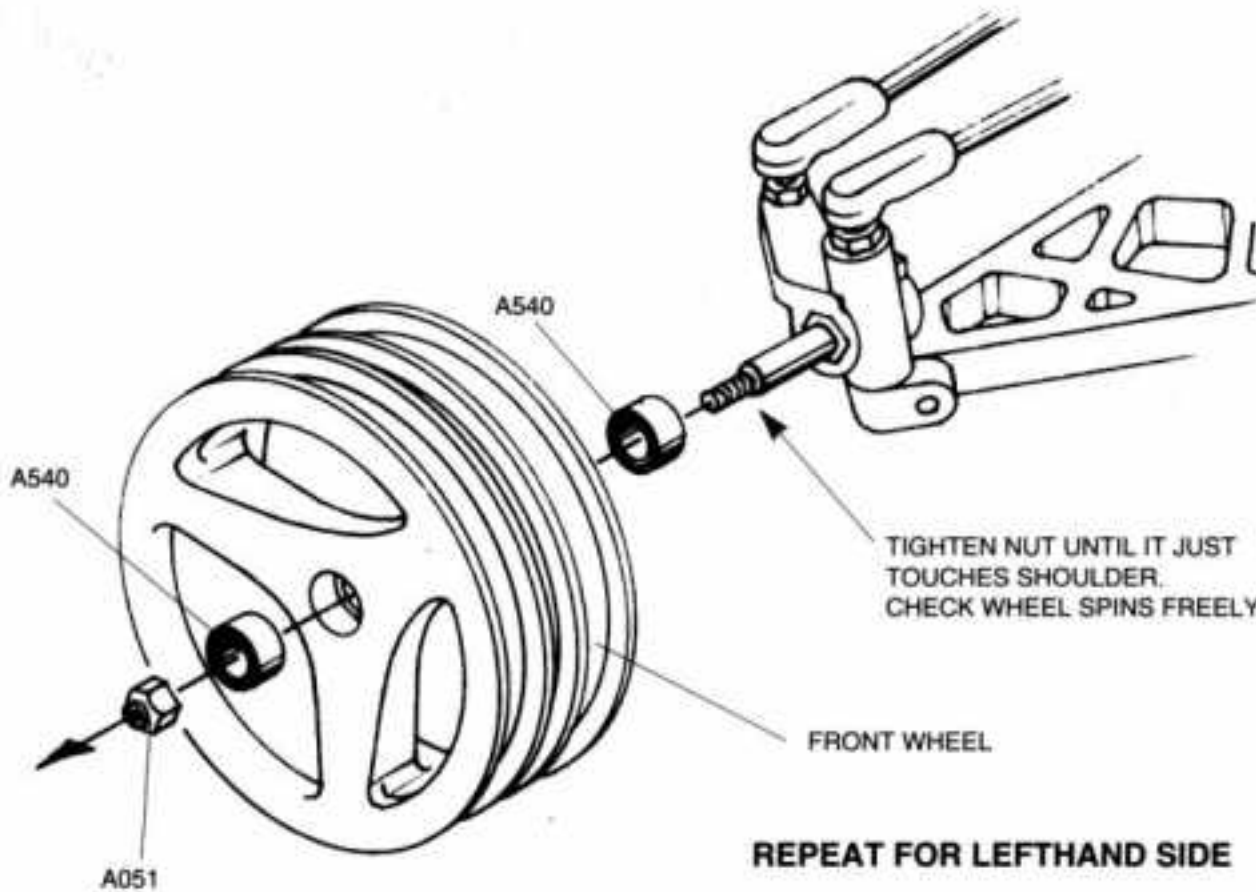

**3 FITTING REAR WHEELS**

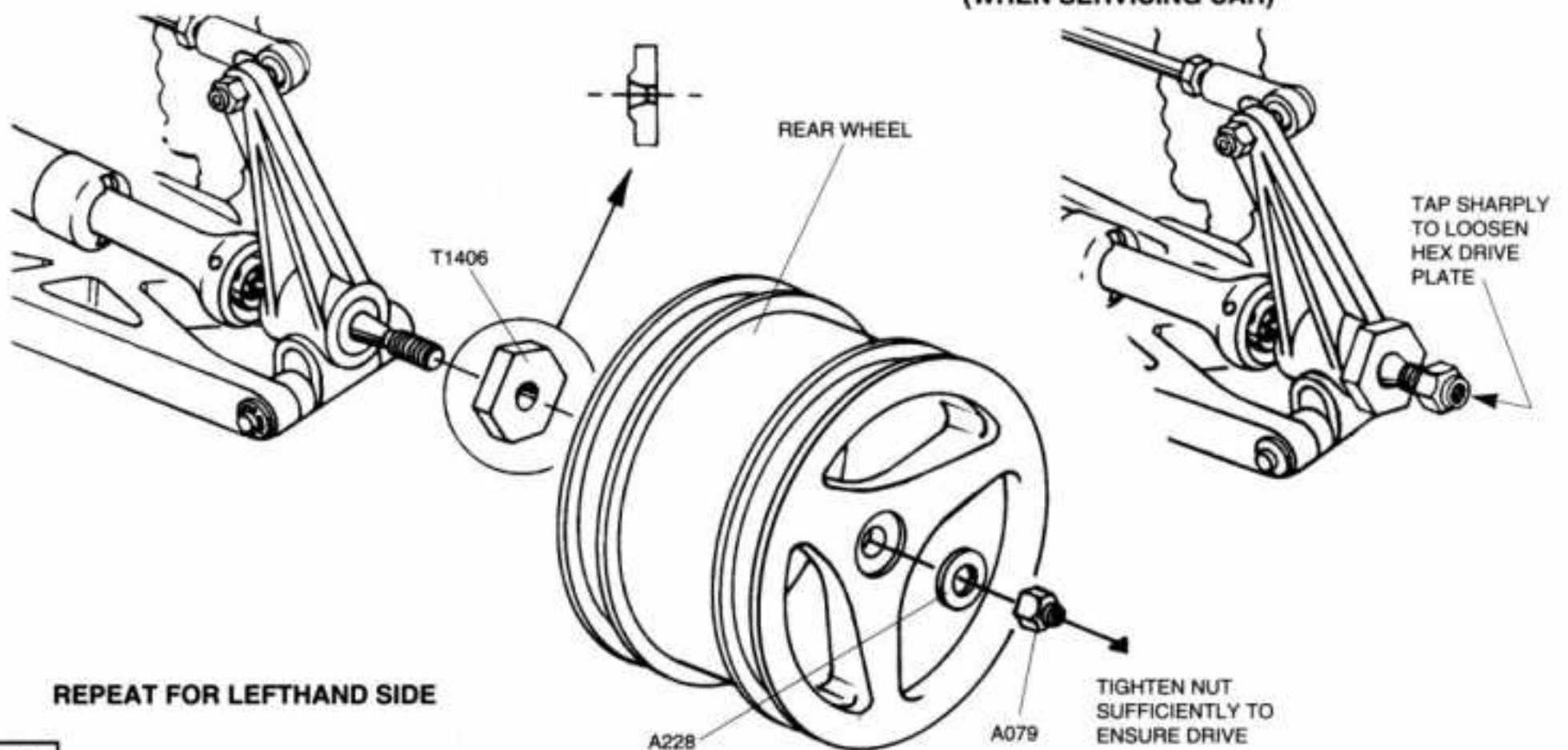

**BODYSHELL**

CUT AWAY SHADED AREAS.

USE A FILE OR ABRASIVE PAPER TO SMOOTH THE CUT EDGES.

ANY RAGGED EDGES OR SCORE LINES MAY CAUSE THE BODYSHELL TO CRACK OR SPLIT WHEN IN USE.

PAINTING: FIRST WASH THE BODYSHELL TO REMOVE ANY OIL OR DIRT. RINSE THOROUGHLY. PAINT THE INSIDE OF THE BODYSHELL AND WING.

YOU CAN OBTAIN A COLOUR SCHEME BY MASKING A SECTION WITH TAPE, PAINTING, THEN REMOVING THE TAPE AND PAINTING A DIFFERENT COLOUR.

APPLY THE DARKEST COLOUR FIRST.

USE DECALS TO FINISH YOUR BODYSHELL.

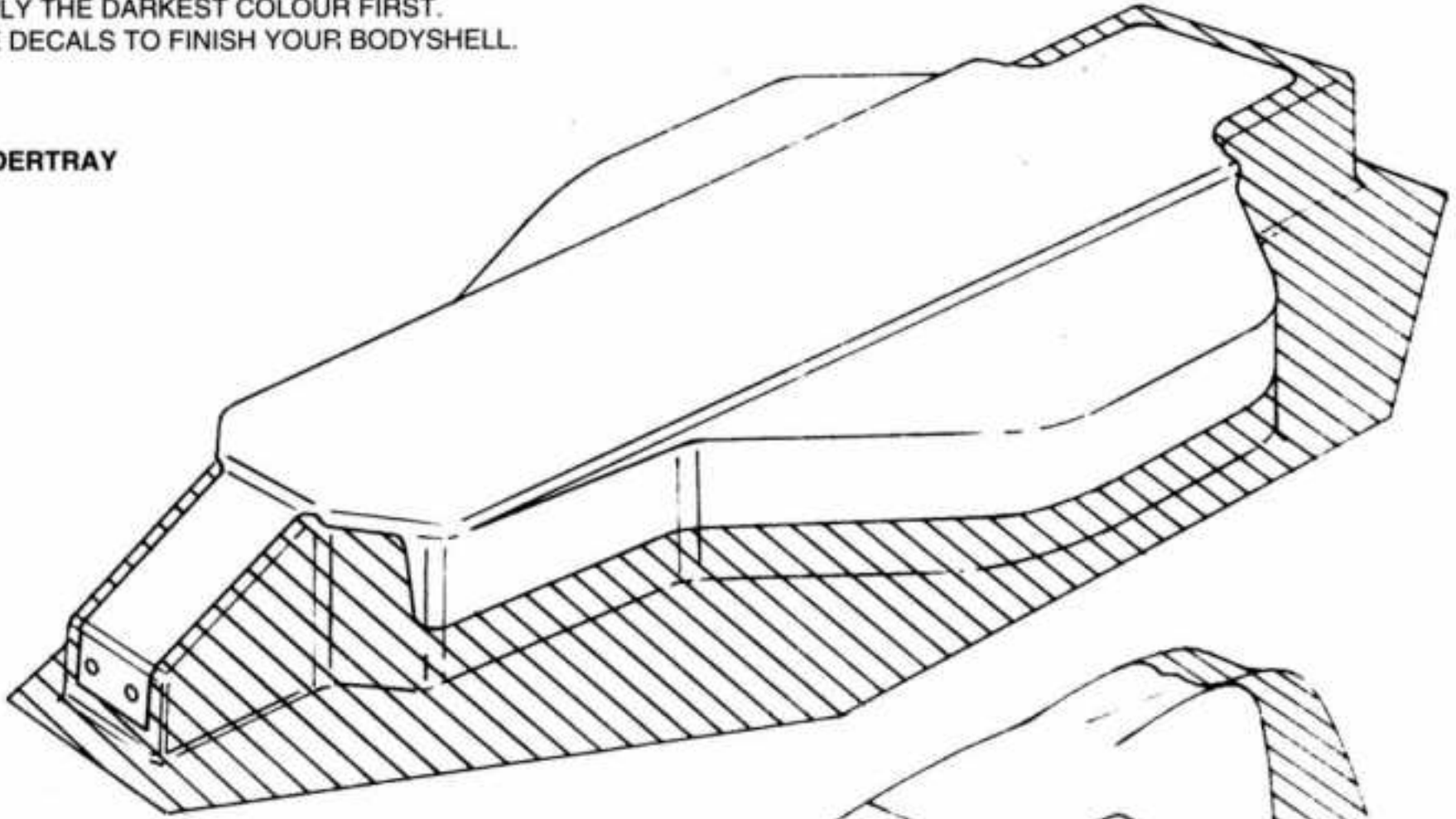
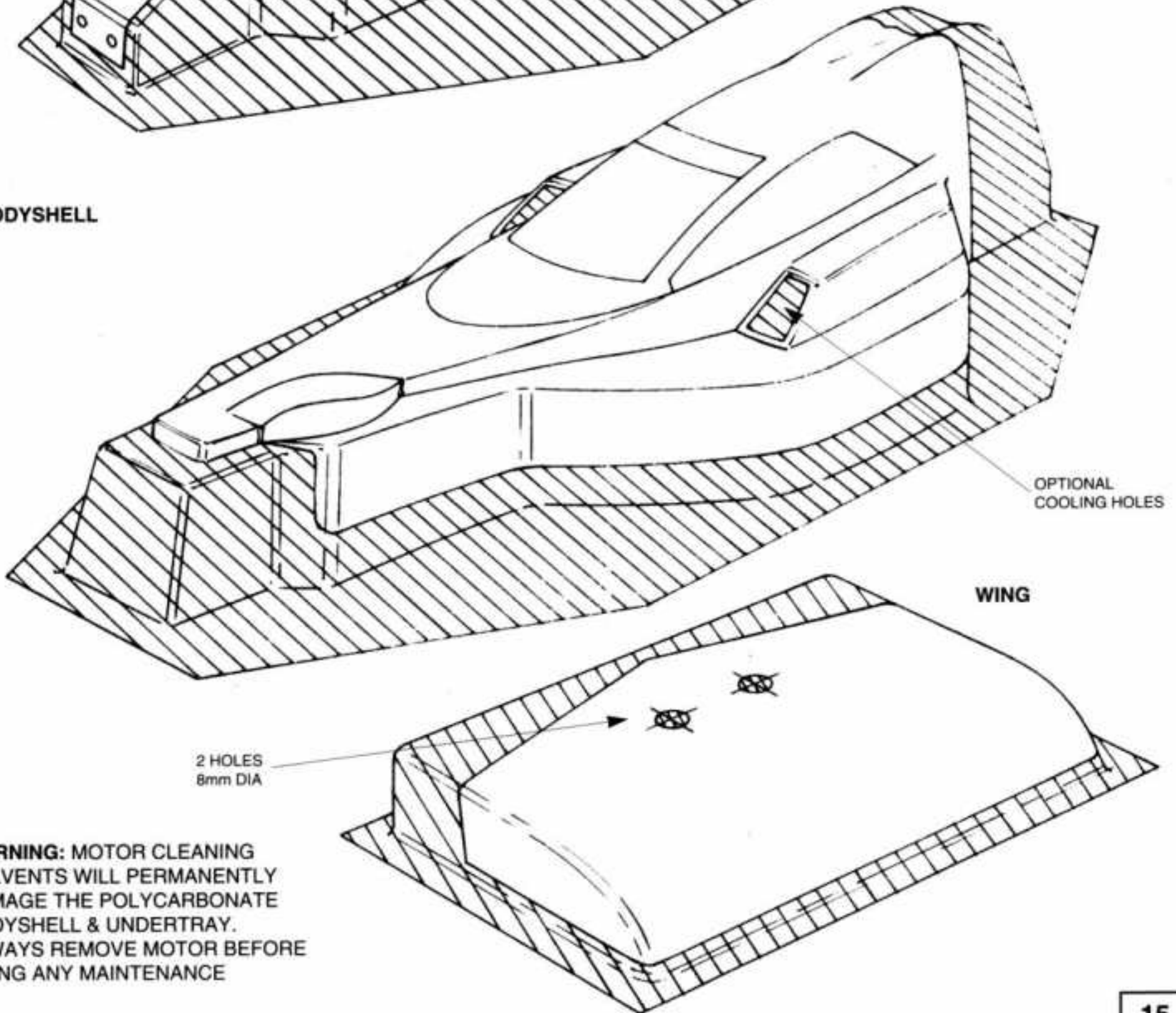
**UNDERTRAY****BODYSHELL**

**WARNING:** MOTOR CLEANING SOLVENTS WILL PERMANENTLY DAMAGE THE POLYCARBONATE BODYSHELL & UNDERTRAY. ALWAYS REMOVE MOTOR BEFORE DOING ANY MAINTENANCE

**1 FRONT BUMPER AND UNDERTRAY**

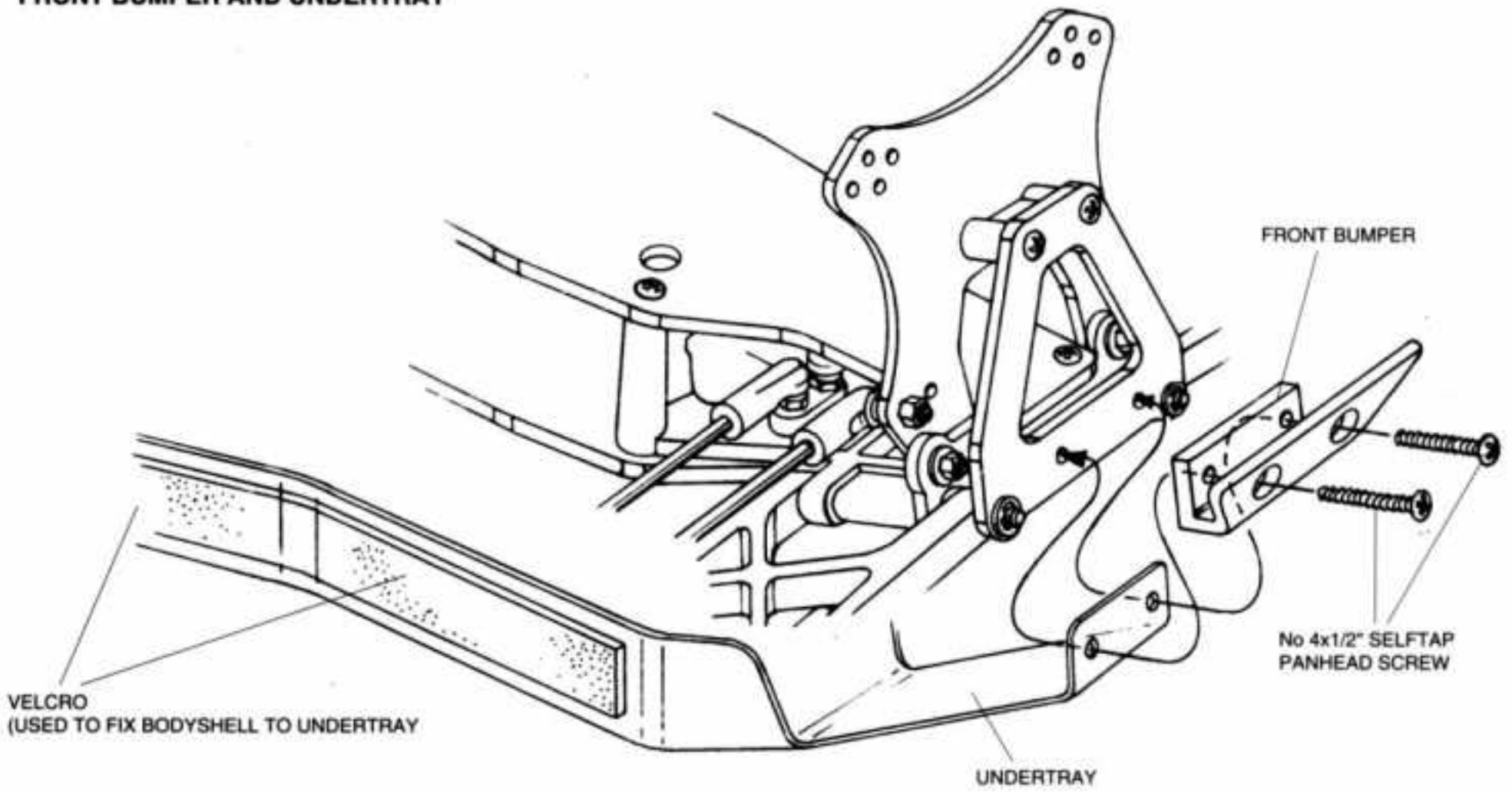

**2 REAR BUMPER**

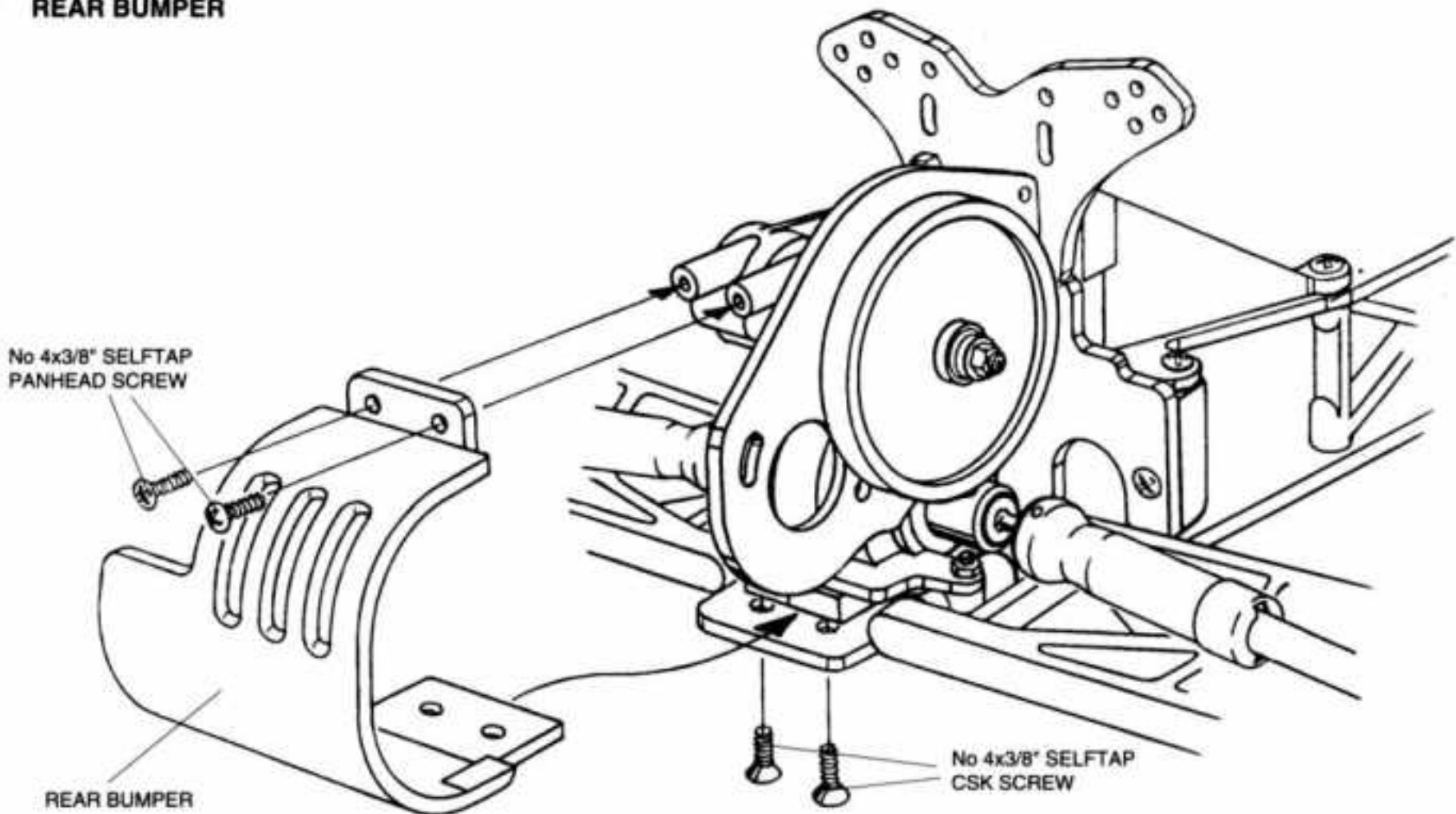

## SOLDERING UP NICADS

IF USING TUBE CONNECTORS  
SOLDER UP AS SHOWN

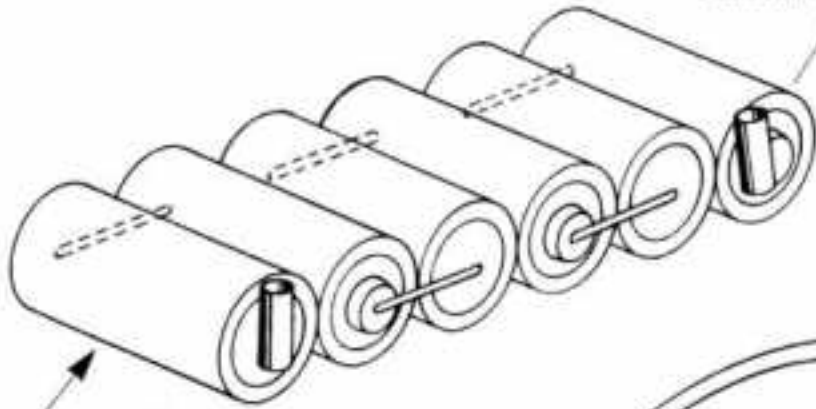

IF YOU ONLY RUN A 2WD CAR  
SOLDER NICADS LIKE THIS

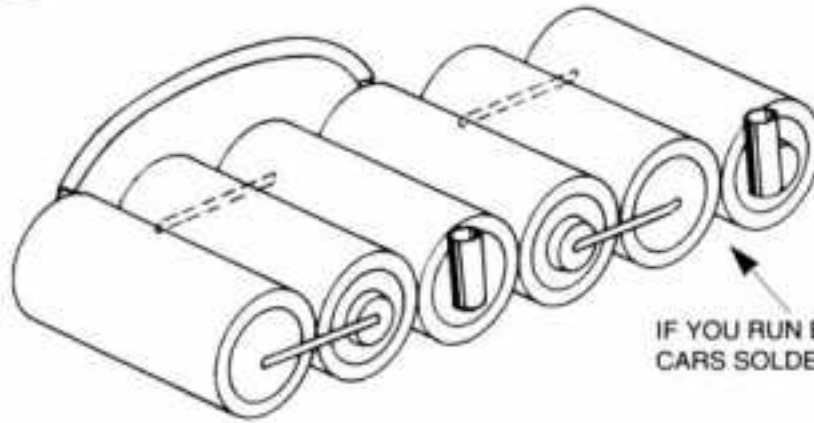

IF YOU RUN BOTH 2WD & 4WD  
CARS SOLDER NICADS LIKE THIS

**Schumacher**

**COUGAR  
2000**

## FITTING NICADS

**BOTH THESE  
CONFIGURATIONS RESULT IN  
THE LEAST RESISTANCE AND  
SO GIVE BETTER NICAD  
PERFORMANCE**

### FITTING SADDLE PACK

NICAD STRAP  
(NOTE WHICH WAY UP)

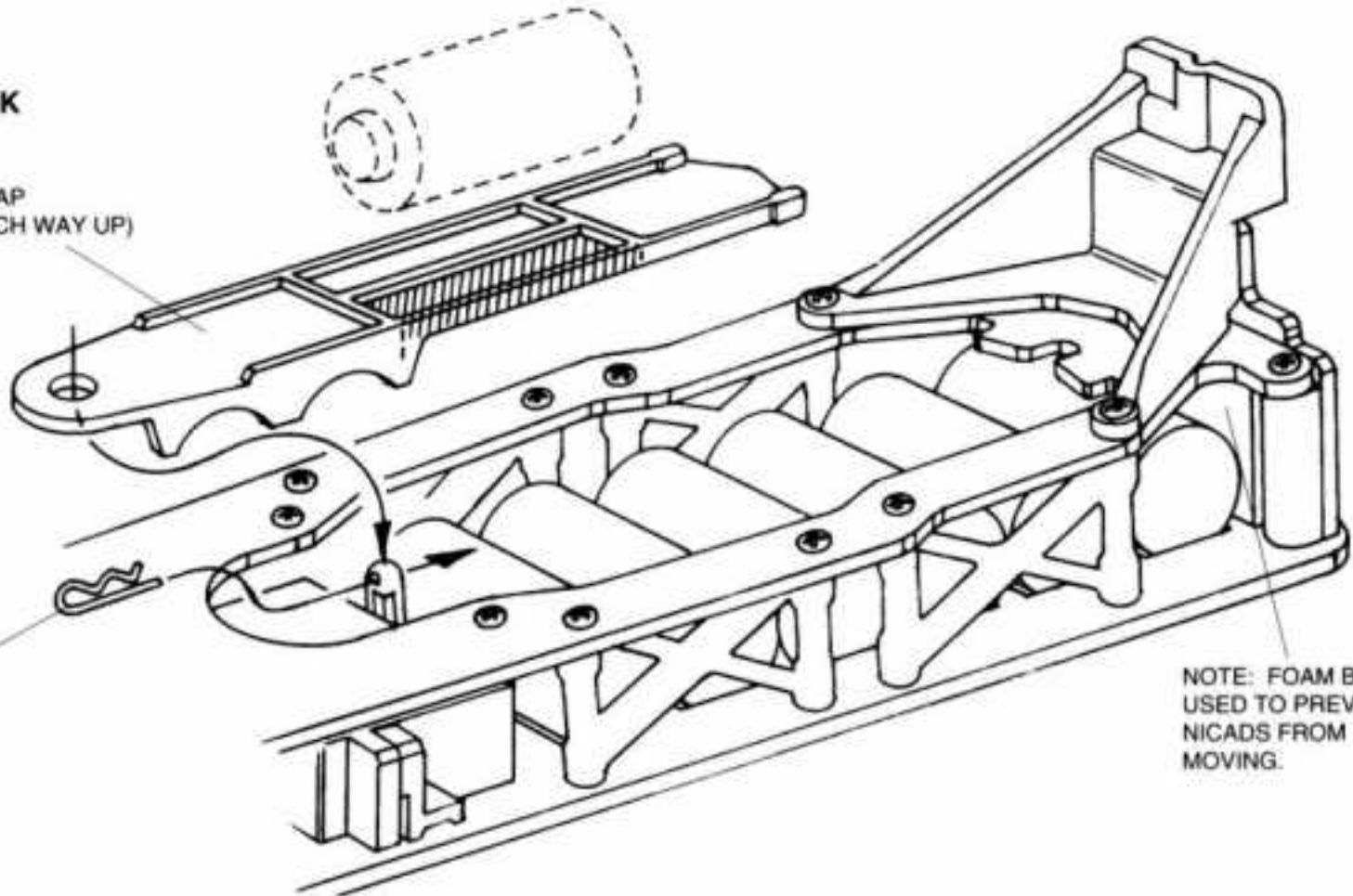

IF USING 7 CELLS CUT  
AWAY SHADED AREA OF  
NICAD STRAP AND  
MOUNT NICAD AS  
SHOWN

'R' CLIP

NOTE: FOAM BLOCK -  
USED TO PREVENT  
NICADS FROM  
MOVING.

### FITTING STICK PACK

NICAD STRAP  
(NOTE WHICH WAY UP)

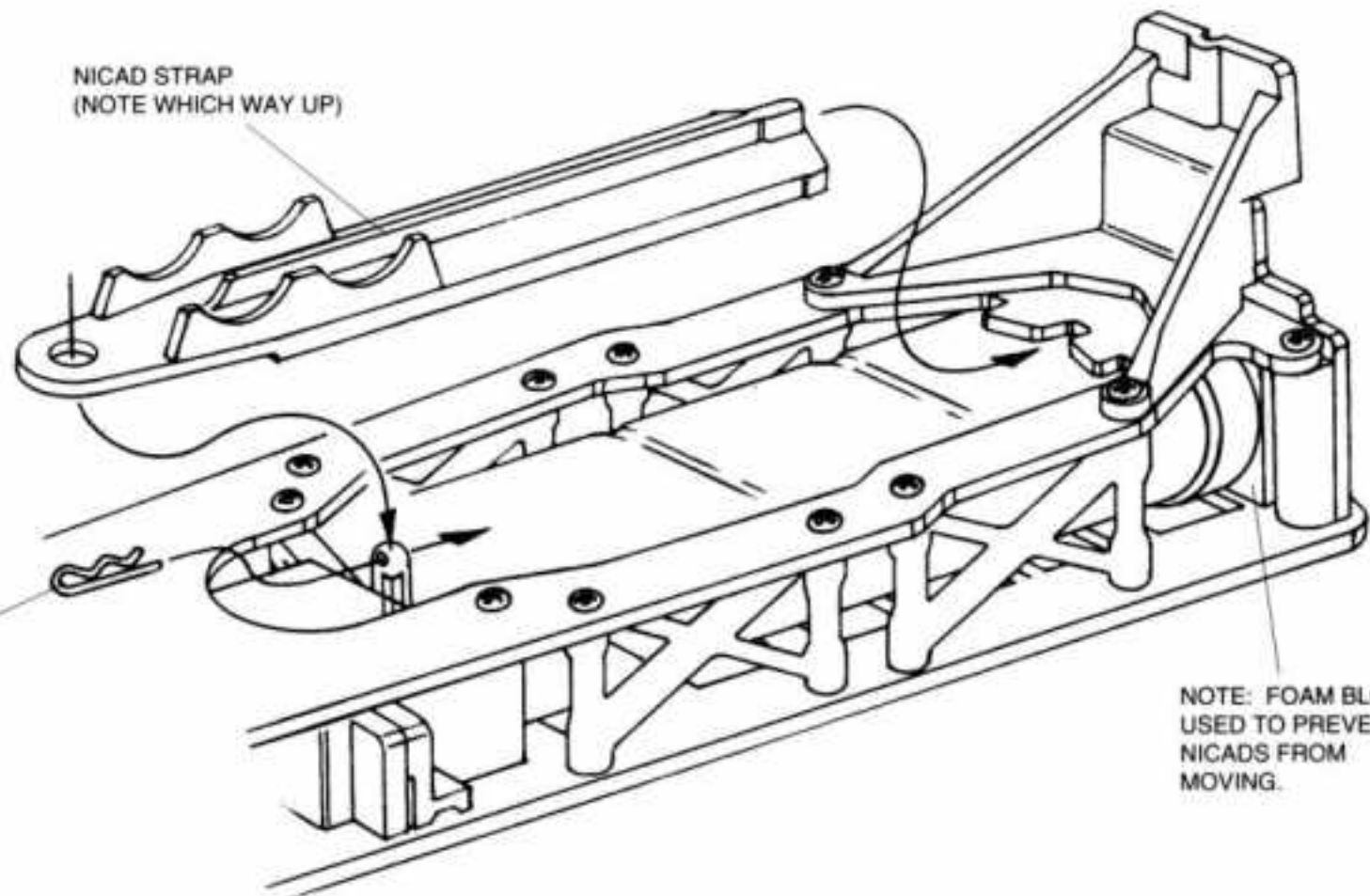

'R' CLIP

NOTE: FOAM BLOCK -  
USED TO PREVENT  
NICADS FROM  
MOVING.

**WING & GEAR COVER**

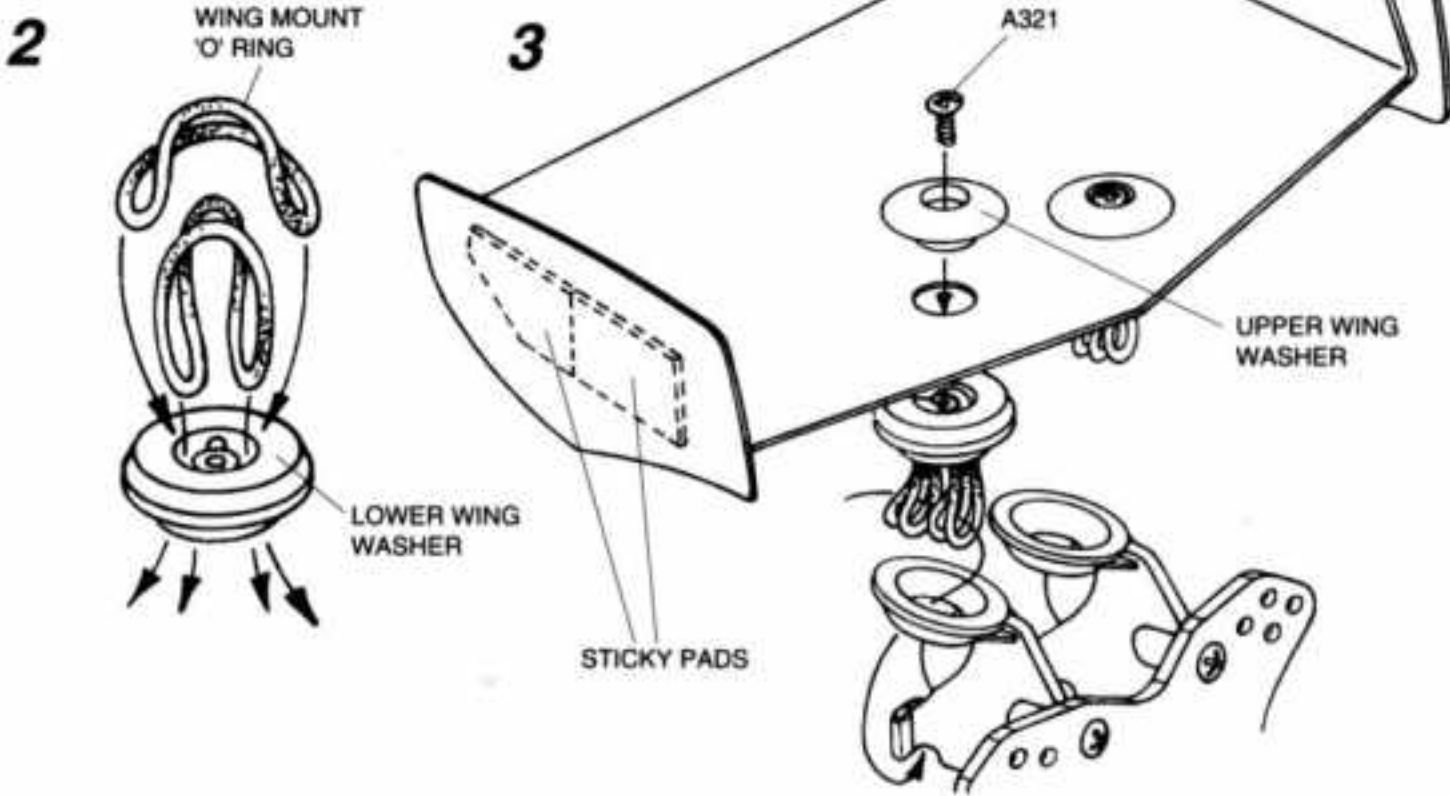
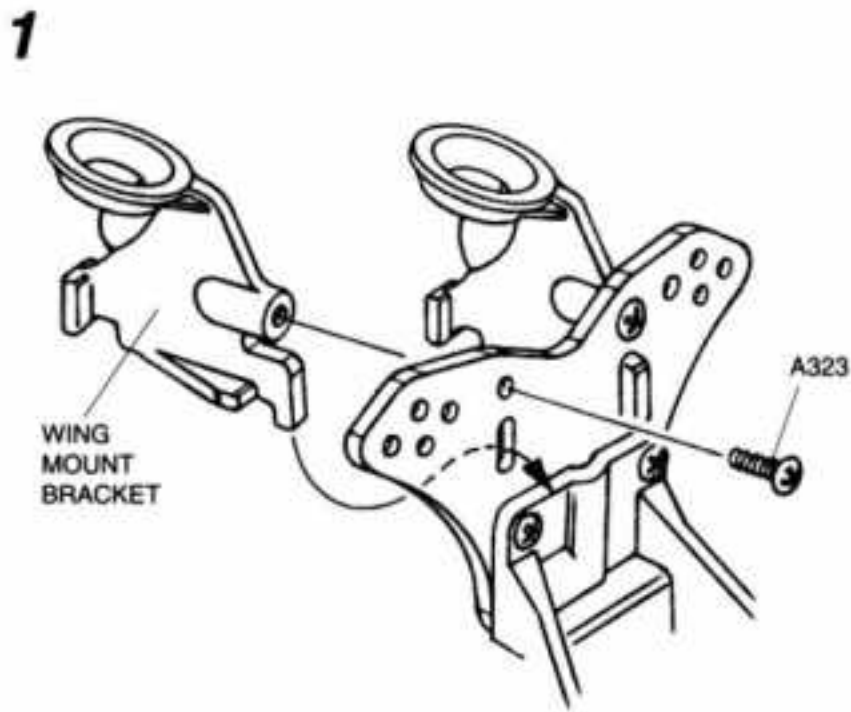

A323 No4x3/8" SELFTAP PANHD SCREW  
X2

A321 No4x1/4" SELFTAP PANHD SCREW  
X2

A225 M3 STEEL WASHER  
X2

A032 M3x6mm CHEESEHEAD SCREW  
X2

A067 M3x4mm PANHD SCREW  
X2

**WARNING: MOTOR CLEANING SOLVENTS WILL PERMANENTLY DAMAGE THE POLYCARBONATE GEAR COVER. ALWAYS REMOVE MOTOR BEFORE DOING ANY MAINTENANCE**

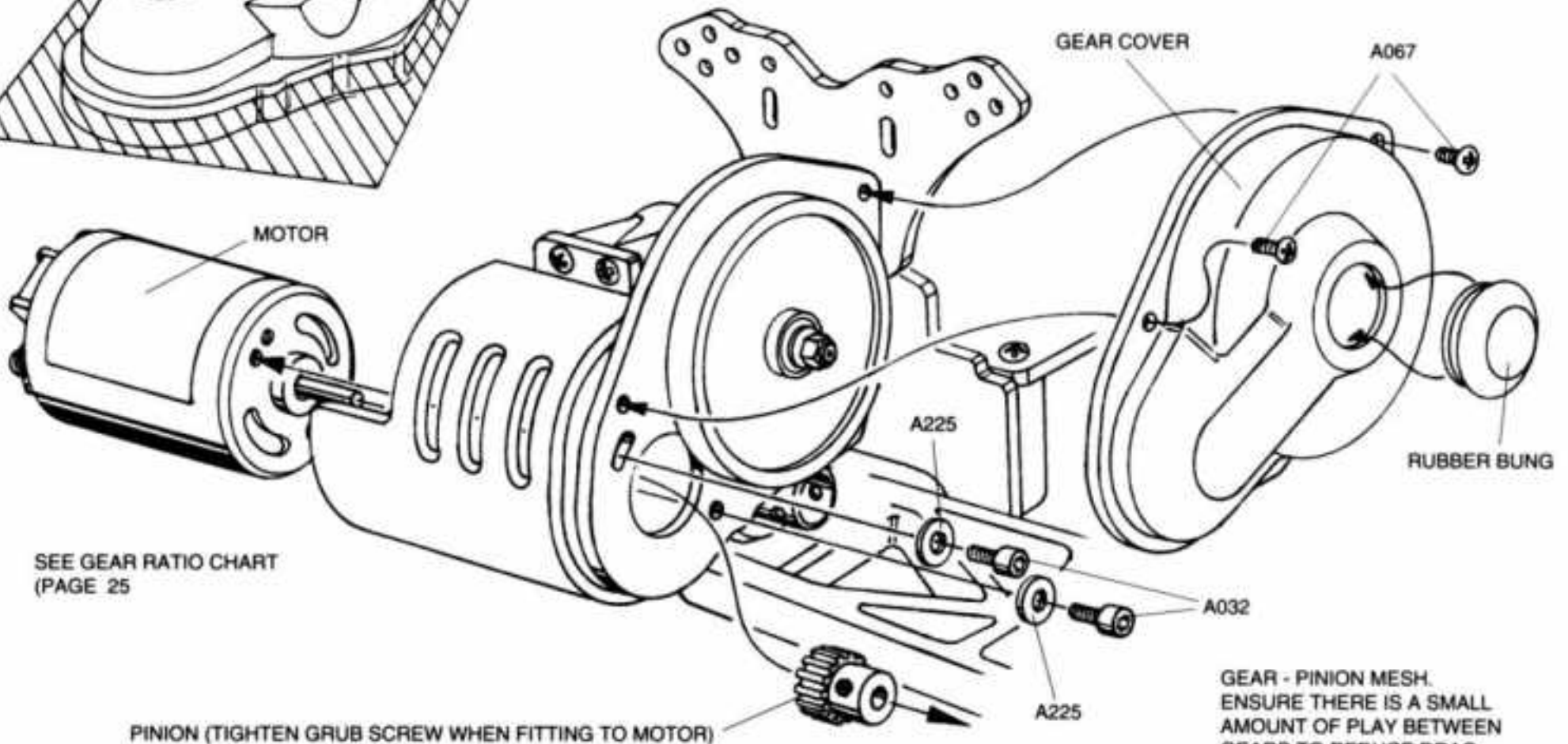
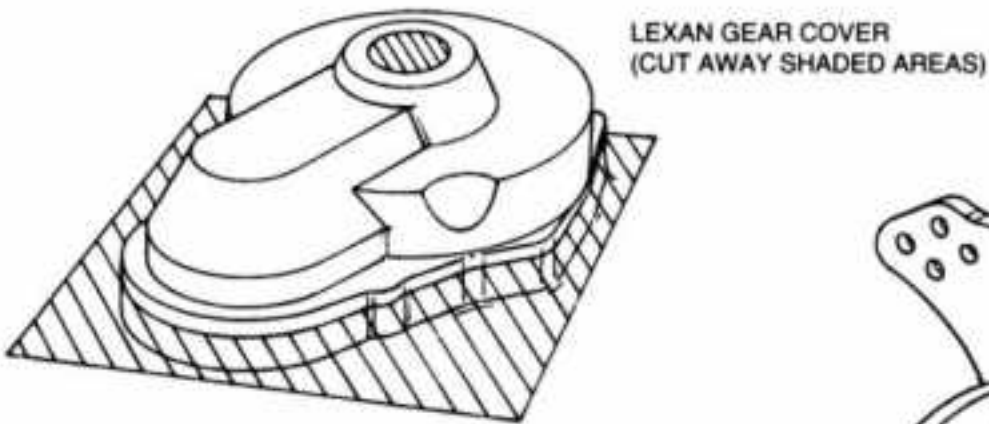

SEE GEAR RATIO CHART (PAGE 25)

GEAR - PINION MESH. ENSURE THERE IS A SMALL AMOUNT OF PLAY BETWEEN GEARS TO REDUCE DRAG.

CONSULT THE INDIVIDUAL  
INSTRUCTION SHEETS SUPPLIED  
WITH YOUR OWN RADIO  
CONTROL EQUIPMENT AND  
SPEED CONTROLLER WHEN  
FITTING INTO CAR

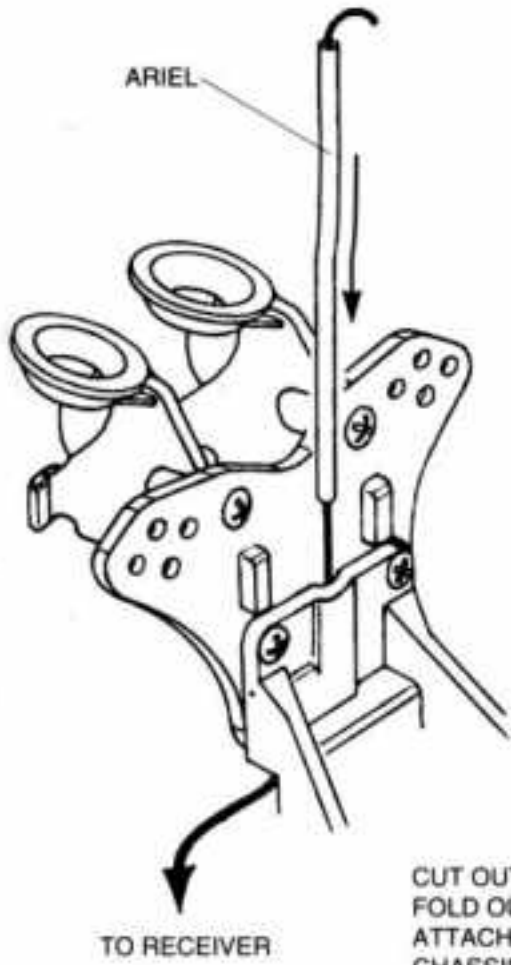

**FITTING  
RADIO TRAYS**

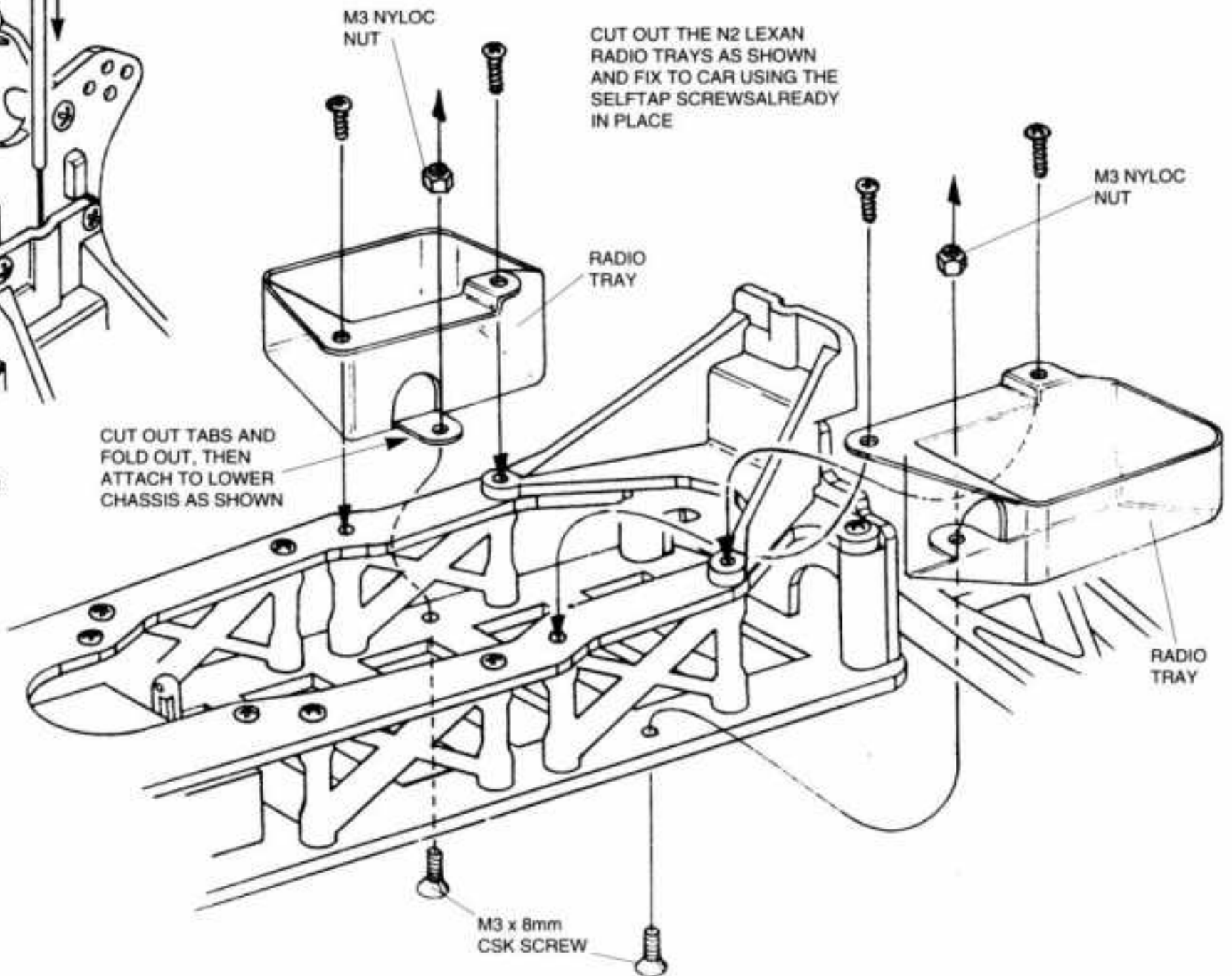

**FITTING RADIO EQUIPMENT**

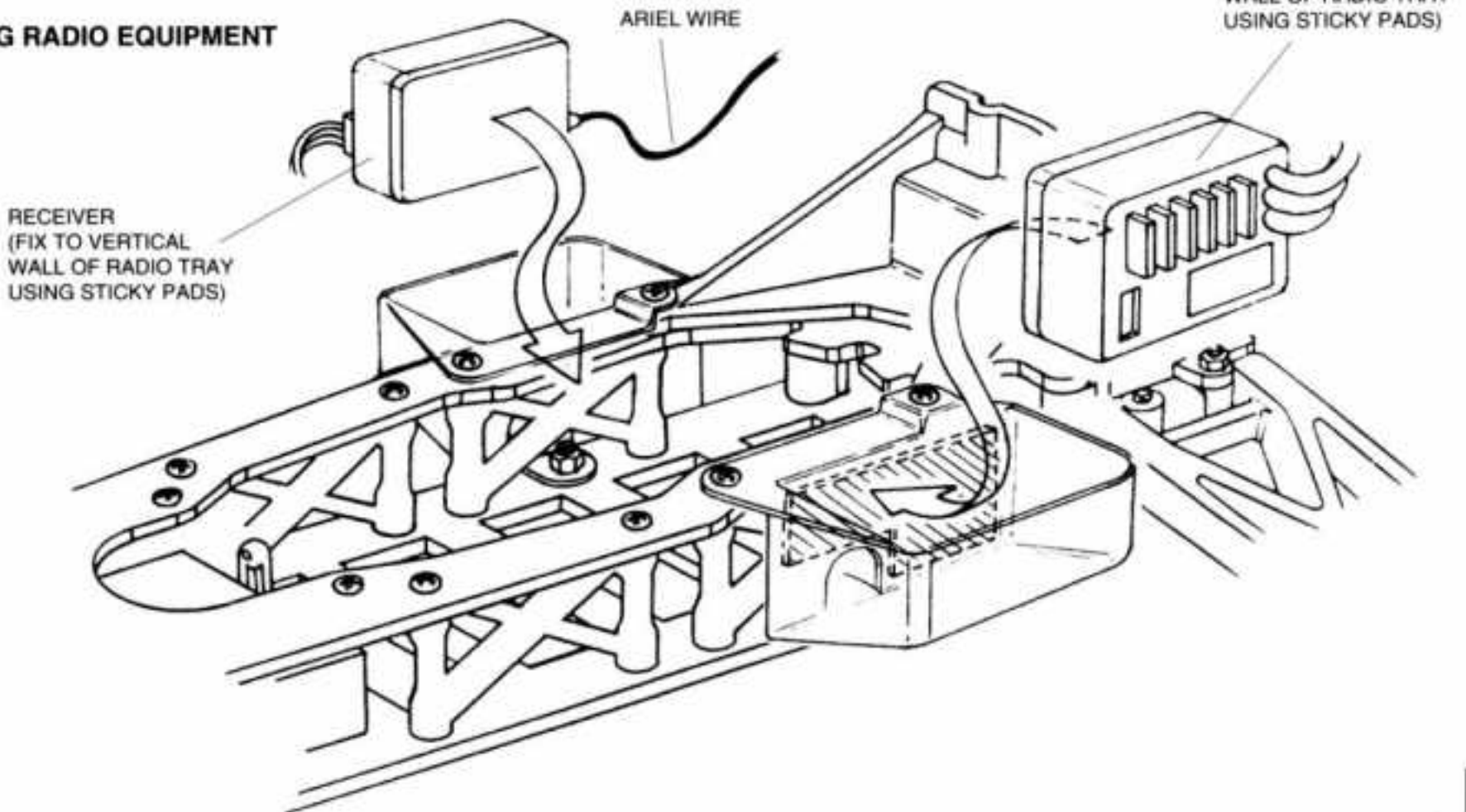

**1 REMOVING TRANSMISSION**  
REMOVE THE 2 NUTS ON THE  
REAR PIVOT BRACE  
UNSCREW THE 8 SCREWS SHOWN

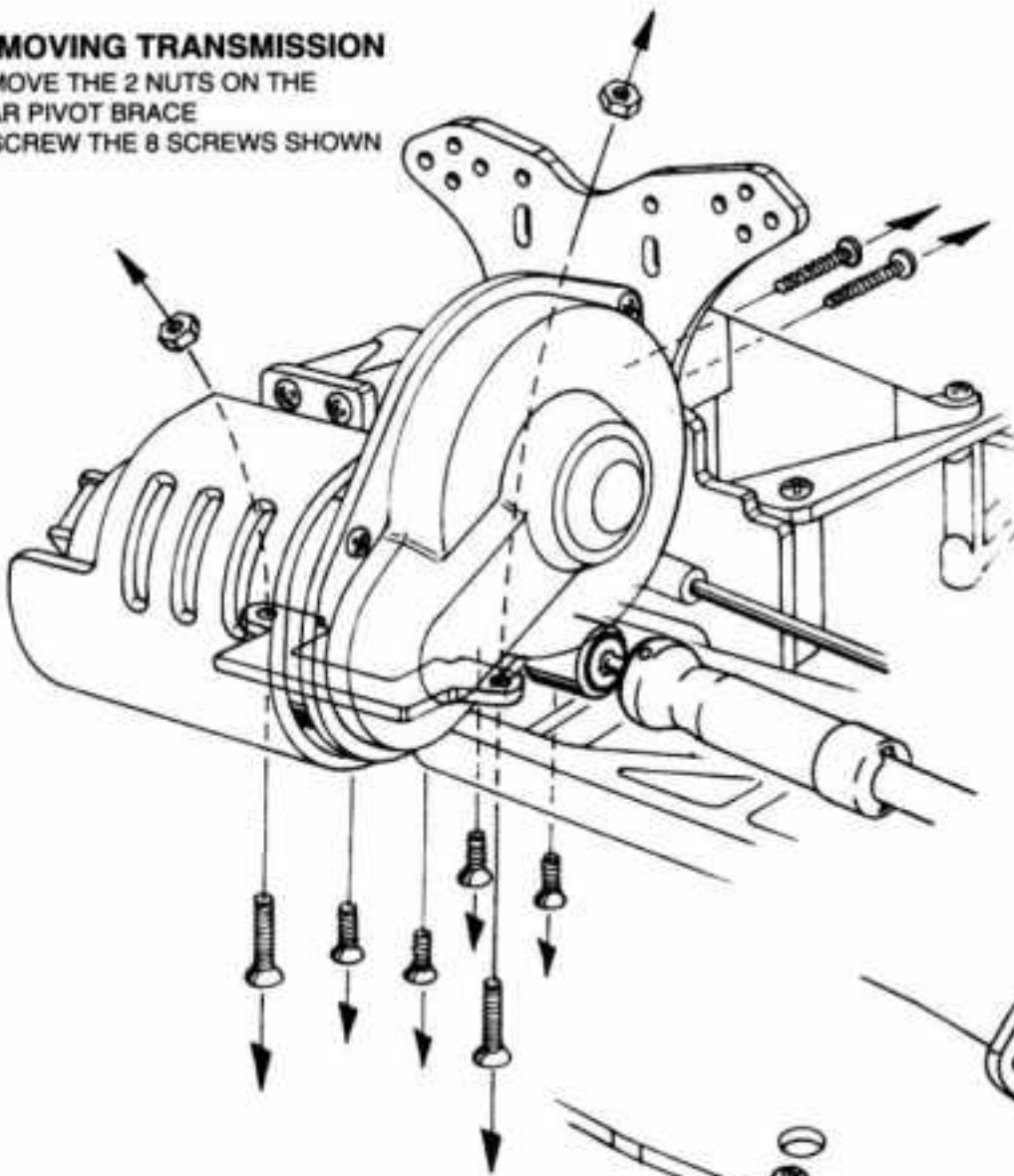

**2 REMOVING FRONT SUSPENSION**  
UNSCREW ONLY THE 7 SCREWS SHOWN  
(THE FRONT SUSPENSION CAN BE  
REMOVED AS A COMPLETE UNIT)

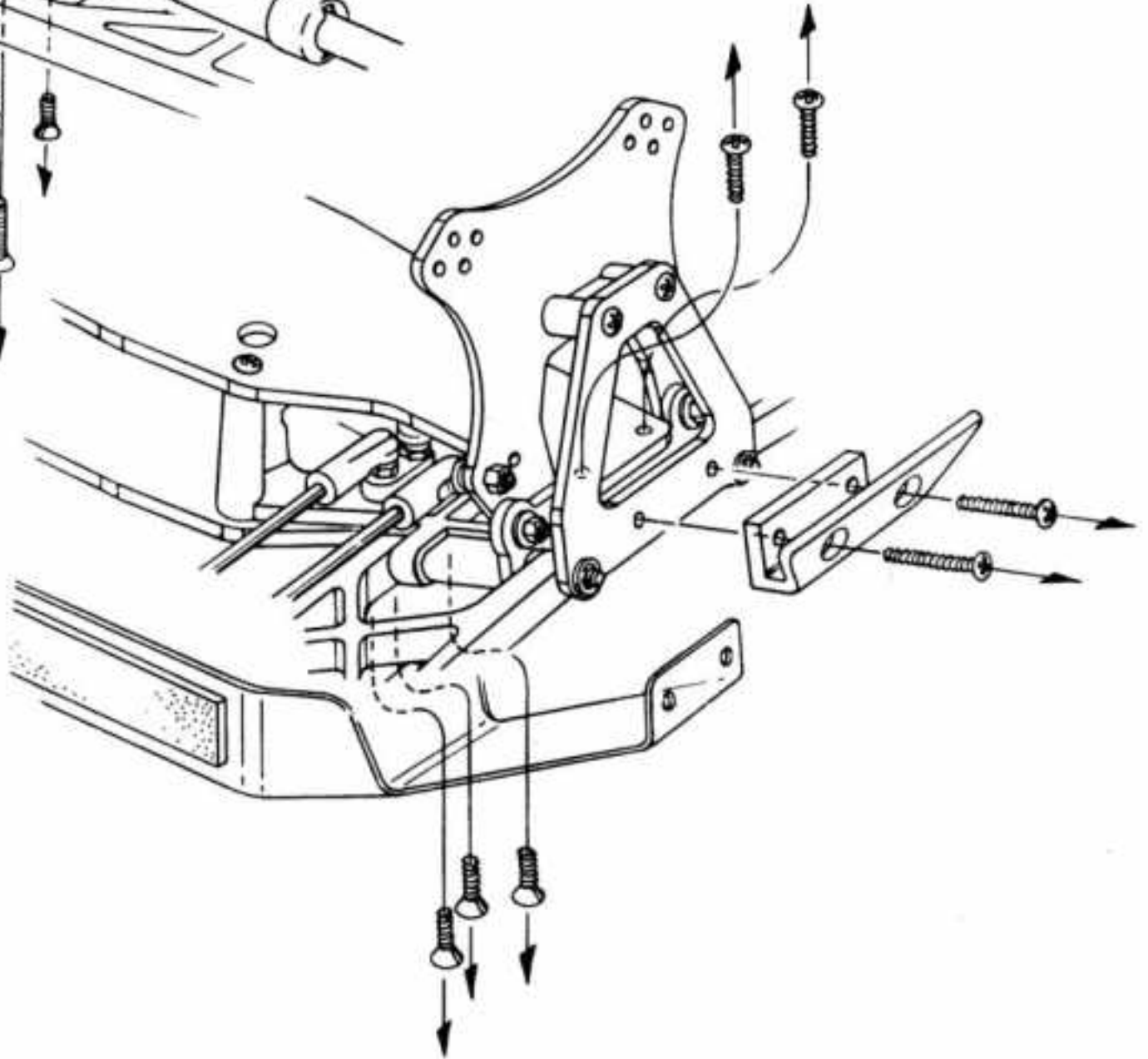

**3 REMOVING REAR  
SUSPENSION**  
REMOVE 2 REAR 'E' CLIPS  
SLIDE FORWARD PIVOT  
PINS AS SHOWN

(NOTE: DIAGRAM  
SHOWS  
TRANSMISSION NOT IN  
PLACE.  
THIS IS TO MAKE  
DIAGRAM  
CLEARER.  
YOU DO NOT HAVE  
TO REMOVE  
TRANSMISSION  
TO REMOVE THE REAR  
WISHBONES

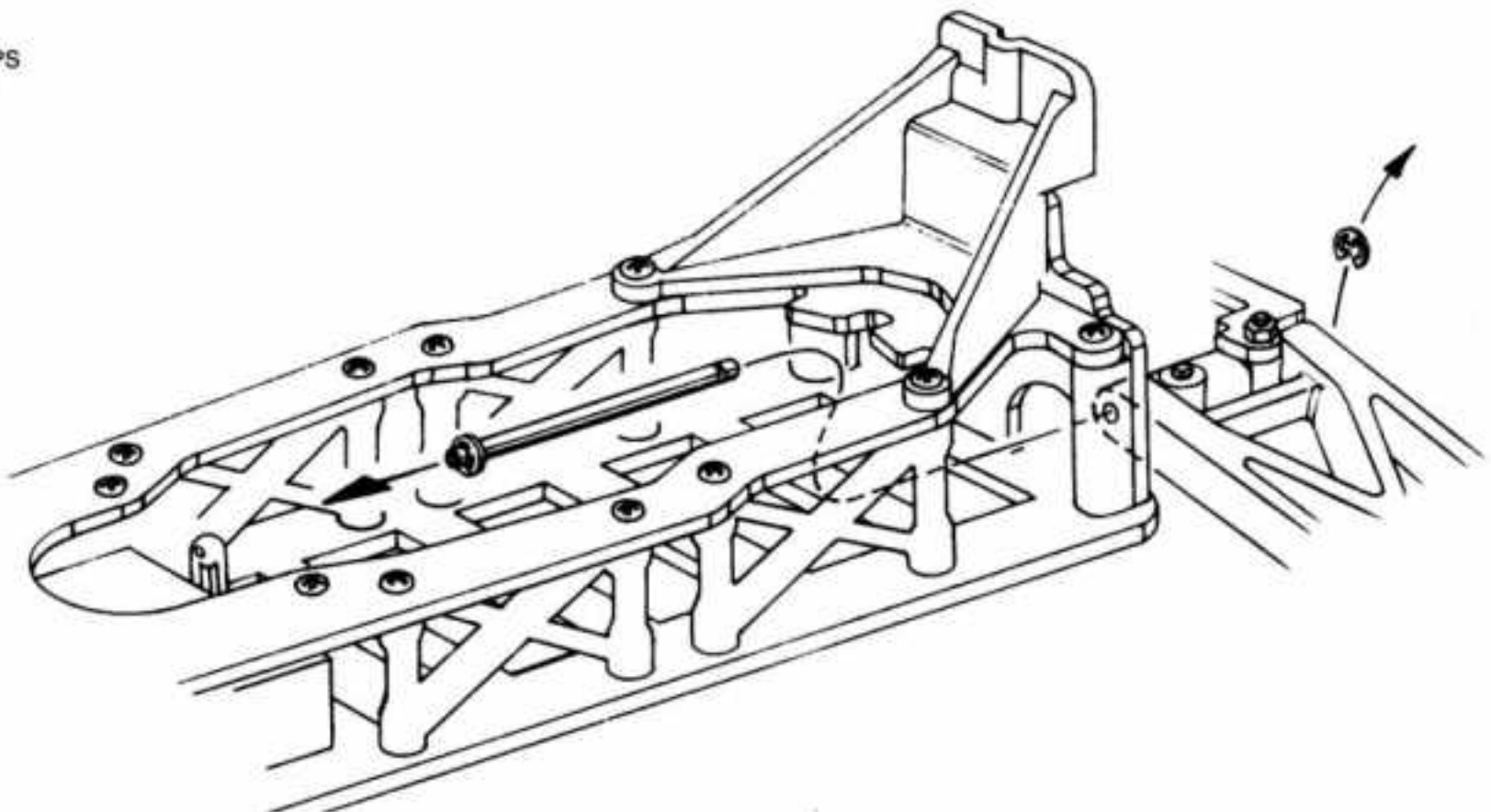

## TRACK SETTINGS

The table below shows the set up as kit build and set ups for certain types of track.  
Use these as starting points.  
Pages 22, 23, 24 and 25 explain in detail how each adjustment affects the cars handling. Use these steps for fine tuning.

On the back cover is a set up sheet which can be photocopied and used to build up a reference record of track conditions and track settings.

ADJUSTMENT	CAR BUILT AS BOOK	PACKED DIRT -DAMP	MULTI SURFACE. ASTRO TURF & ASPHALT	PACKED DIRT -DRY	GRASS	LOOSE SHALE -DRY
<b>FRONT SUSPENSION</b>						
FRONT CAMBER	1°	1°	1°	1°	1°	1°
FRONT TOE-IN	STRAIGHT	STRAIGHT	STRAIGHT	STRAIGHT	STRAIGHT	STRAIGHT
ACKERMANN EFFECT	30	30	30	30	30	30
TOP LINK POSITION	B	B	B	B	B	B
<b>REAR SUSPENSION</b>						
REAR CAMBER	1°	1°	1°	1°	1°	1°
REAR TOE-IN	3°	4°	5°	5°	3°	4°
ANTI SQUAT	STANDARD	5°	5°	5°	5°	5°
REAR HUB CARRIER PIN LOCATION	LOW	HIGH	HIGH	HIGH	LOW	HIGH
TOP LINK POSITION	3	3	3	3	3	3
WHEELBASE	MED	MED	LONG	SHORT	MED	MED
<b>SHOCK ABSORBERS - FRONT</b>						
SPRINGS	YELLOW	YELLOW	GREY	YELLOW	GREY	WHITE
OIL	30W	25W	40W	30W	35W	25W
SHOCK POSITION - WISHBONE	MIDDLE (No2)	MIDDLE (No2)	OUTER (No3)	MIDDLE (No2)	OUTER (No3)	MIDDLE (No2)
SHOCK POSITION - TOP	2	1	4	1	4	4
HOLES OPEN IN PISTON	4	4	4	4	4	4
(SUSPENSION STIFFNESS)	3.3					
(SUSPENSION DAMPING)	14.6					
<b>SHOCK ABSORBERS - REAR</b>						
SPRINGS	YELLOW	WHITE	GREY	YELLOW	GREY	YELLOW
OIL	30W	30W	60W	40W	35W	40W
SHOCK POSITION - WISHBONE	MIDDLE (No2)	MIDDLE (No 2)	MIDDLE (No2)	MIDDLE (No2)	OUTER (3)	MIDDLE (NO2)
SHOCK POSITION - TOP	2	4	4	3	3	4
HOLES OPEN IN PISTON	4	4	4	4	4	4
(SUSPENSION STIFFNESS)	8.2					
(SUSPENSION DAMPING)	25.2					
<b>TRANSMISSION</b>						
SLIPPER CLUTCH (SLIP DIST)	0.75 METRES					
PINION		19T	18T	18T	17T	17T
SPUR GEAR	95T	89T	95T	89T	89T	95T
MOTOR TURN		13 DOUBLE	11 DOUBLE	11 TRIPLE	12 DOUBLE	11 TRIPLE
<b>TYRES</b>						
FRONT	T689G	U6519N (F)	U6550S (F)	U6570M (F)	T689G	U650M (F)
REAR	U6518M	U6516K (F)	U6516K (F)	U6565H (F)	U6518M	U6567J (F)
<b>OPTIONAL EXTRAS</b>						
REAR ANTI-ROLL BAR		NO	NO	NO	NO	NO

TYRES: F = FOAM INSERT

**REAR TOP LINK BRACKET**

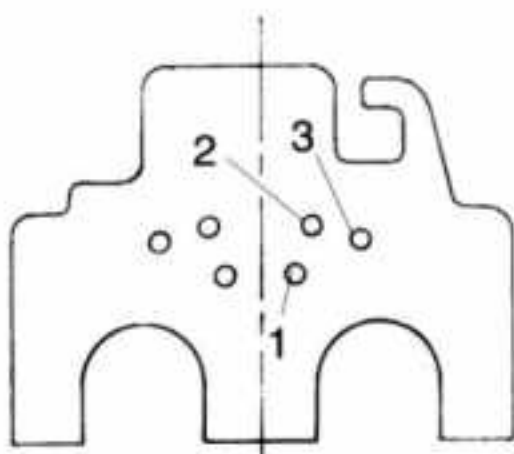

**FRONT SHOCK BRACKET**

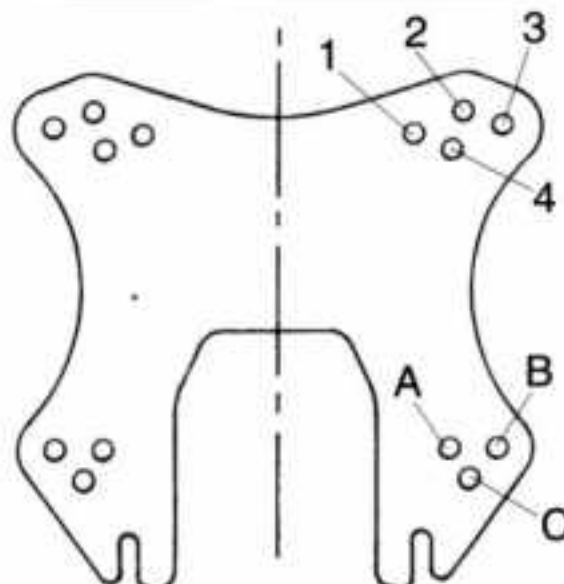

**REAR SHOCK BRACKET**

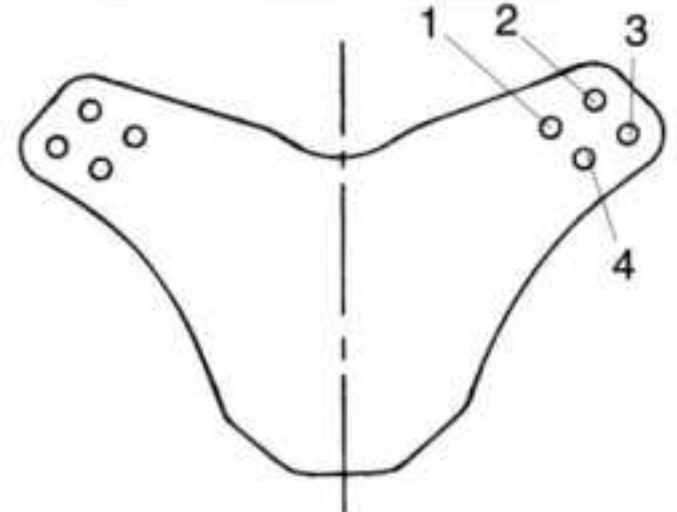

**1** Make sure screws are tight, recheck after each race.

**2** **TYRES**  
The front and rear tyres in the kit will give safe predictable handling for most conditions. However, Schumacher CAT range of tyres offer a wide range of options to cover all extremes of operating conditions. The spikes on the tyres may be cut to adjust the handling. For the full range of Schumacher tyres see list on centre pages.

**3** **WHEELBASE**  
The cars wheelbase can be altered by moving the washers that sit between the rear hub carrier and the wishbone. There are 3 possible settings. Generally the shorter wheelbase gives more rear traction, a longer wheelbase improves steering response.

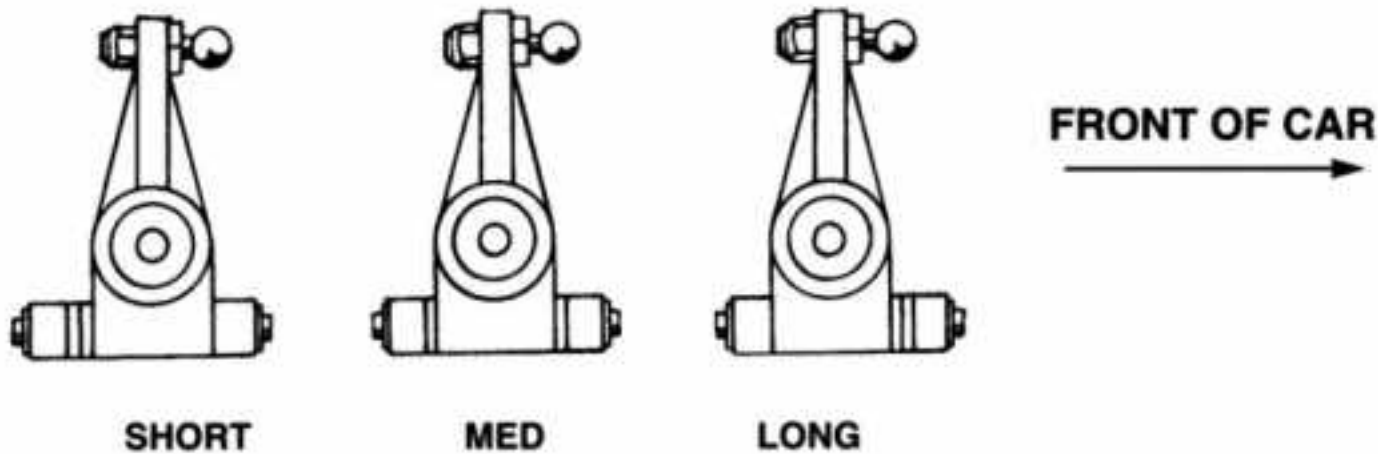

**4** **DIFF**  
If the differential is correctly built as in the transmission steps it should not need to adjusting during racing. Any slip adjustment should be done on the slipper clutch. **DO NOT LOOSEN THE THE DIFF TO ACHIEVE SLIP.** During maintenance when cleaning diff be careful to reassemble the correct way. If diff does become loose (noticeable by a 'squark' coming from the car when accelerating from standstill) tighten by following steps in Transmission section.

**5** **REAR CAMBER**  
The rear wheels should be set at negative camber. This means that the top of the wheels lean inward. Adjustment is carried out by turning the top link. The righthand thread of the link is nearest the hex. Adjust to be the same both sides. Too much negative camber and you will have begin to have less traction.

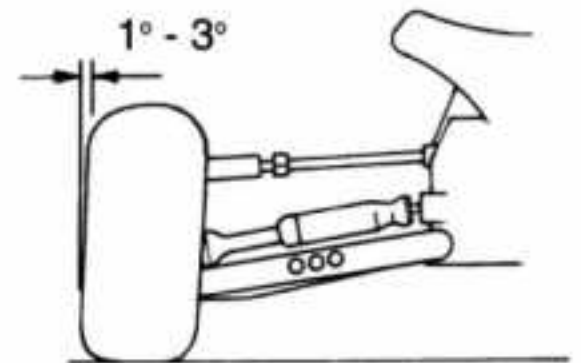

**6** **FRONT CAMBER**  
The rear wheels should be set at negative camber. Adjust to be the same both sides. Generally the more negative camber, the more steering you will get at high and medium speeds. Too much negative camber and you will begin to have less steering.

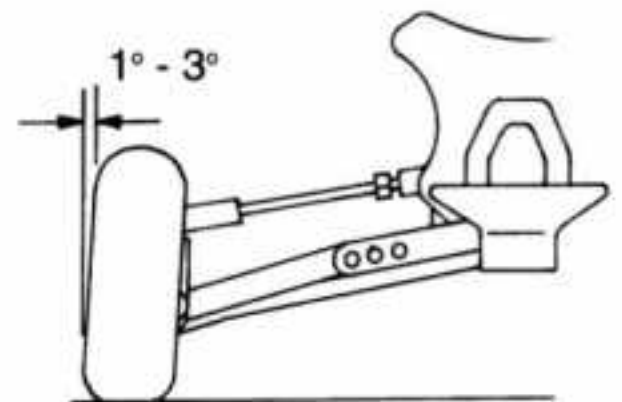

**7** **FRONT TOE IN**  
The front track rods are adjustable, similar to the suspension top links. Set the front wheels to be parallel to each other when pointing straight ahead. If conditions are slippery add 1 - 2 deg toe-in, this will make the car steer a little less. Toe-out will give more steering at low speed, but may make the car more unstable on corner exit.

A greater than B = toe-out  
A less than B = toe-in  
A equal to B = parallel (standard setting)

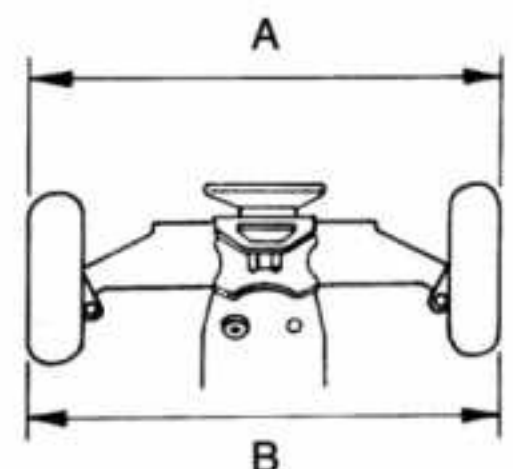

**8** ACKERMANN  
There are two lengths of ackermann link.  
The shorter link will give increased Ackermann effect and improve low speed steering and stability on low grip tracks.

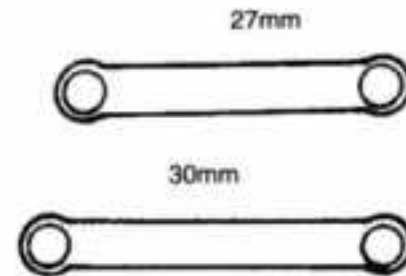
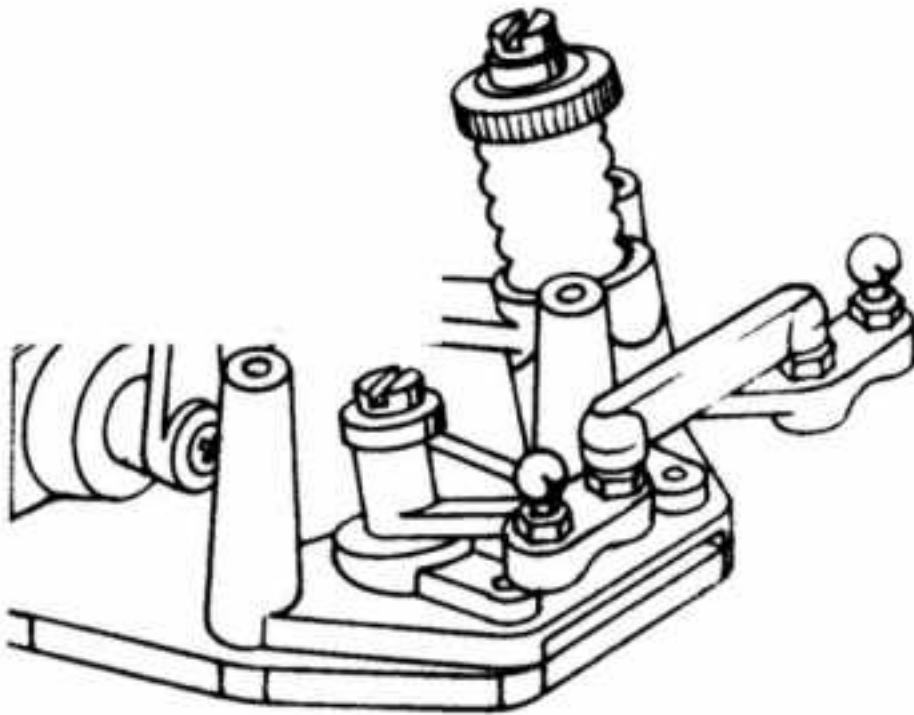

**9** REAR TOE IN & OUT BOARD PIVOT PIN LOCATION  
The rear hub carriers have inserts which alter the toe in and the height of the pivot pin. Each insert moulding has an arrow marked on it and a number, with or without a degree sign (°). There are 3 different inserts, marked 0, 1 and 2. By putting the inserts in the hub carrier in different ways toe in can be varied from 1° to 5°, and the outboard pivot pin can be high or low. The chart shows the possible settings, dealing with the righthand side only. If the righthand side has an insert **with** a degree sign on it, the lefthand side must have the same value insert **without** a degree sign on it - and vice versa.

INSERT	PIVOT PIN LOCATION	ACTUAL TOE IN
2	LOW	1°
1	LOW	2°
0	LOW	3°
0°	LOW	3°
1°	LOW	4°
2°	LOW	5°
2°	HIGH	1°
1°	HIGH	2°
0°	HIGH	3°
0	HIGH	3°
1	HIGH	4°
2	HIGH	5°

**ENSURE TOE IN AND PIVOT PIN LOCATION ARE THE SAME BOTH SIDES.**

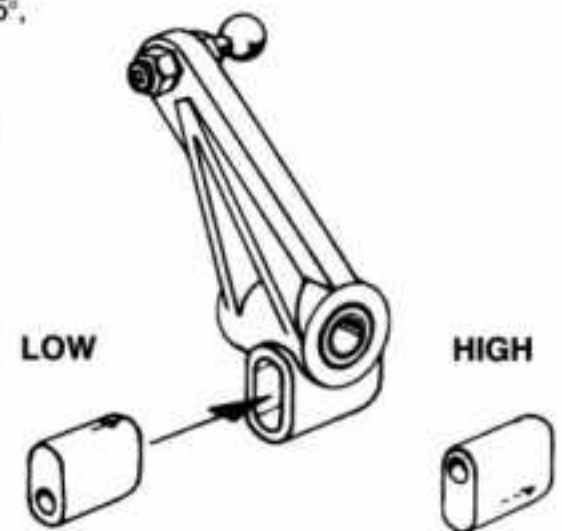

More rear toe in will give more power understeer and more stability and traction at the rear, recommended for tracks with low traction.

The outboard pivot pin :

On low grip tracks run with the pivot pin high (close to the axle). This will give more stability and be better through bumpy corners.

On high grip tracks run with the pivot pin low. This reduces the tendency of the car to understeer.

# 10 SPRING SPACERS / RIDE HEIGHT

Spring spacers only adjust the ride height, not the suspension stiffness. Adjust the spring spacers and shock positions so that your required ride height is achieved but always maintaining some droop travel.

## SUSPENSION TUNING

When setting up your car for handling the choice of damping, spring rate and of mounting holes for the shock absorbers are all very important. These factors combine to give you 'Spring Stiffness' and 'Damping Stiffness' which you must consider when working on the suspension settings of your car.

The 'Spring Stiffness' tables show what is achieved with various combinations of spring rate and wishbone holes. The 'Damping Stiffness' tables show what is achieved with various combinations of piston holes and wishbone holes and oil weight.

The top shock mounting position should be chosen primarily to give the required ride height and is not very significant as far as 'Stiffness' and 'Damping' are concerned. However, as the shock absorber angle becomes more extreme the effective 'Stiffness' and 'Damping' are reduced slightly.

FRONT SPRING STIFFNESS AT WHEEL					
WISHBONE HOLE No.	SPRING				
	WHITE	YELLOW	GREY	BLUE	BLACK
3	3.4	4.5	6.8	9.1	13.7
2	2.6	3.4	5.2	6.9	10.3
1	1.9	2.5	3.7	5.0	7.5

REAR SPRING STIFFNESS AT WHEEL				
WISHBONE HOLE No.	SPRING			
	WHITE	YELLOW	GREY	BLUE
3	7.5	10	15	20.4
2	6.3	8.4	12.6	16.8
1	5.0	6.9	10.5	13.9

**FRONT**

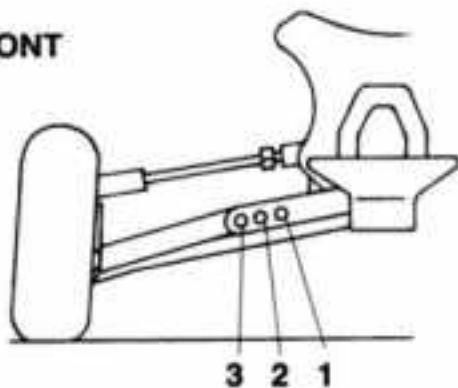

**REAR**

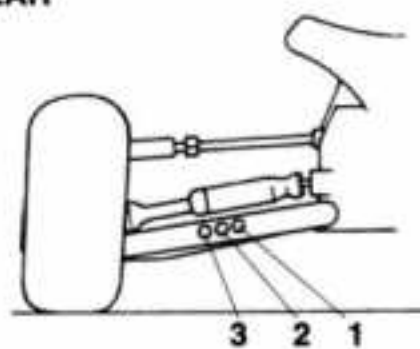

FRONT DAMPER STIFFNESS AT WHEEL					
WISHBONE HOLE No.	No OF HOLES IN PISTON	OIL WEIGHT			
		10W	20W	30W	40W
3	1	15.7	24.1	37.2	48.0
	2	8.1	13.0	21.0	32.5
	3	6.1	9.7	17.4	22.0
	4	4.75	7.4	12.4	16.1
2	1	11.9	18.2	28.1	36.3
	2	6.15	9.85	15.9	24.6
	3	4.6	7.34	13.1	16.6
	4	3.6	5.6	9.4	12.1
1	1	8.6	13.2	20.4	26.3
	2	4.5	7.1	11.5	17.8
	3	3.3	5.3	9.5	12
	4	2.6	4.1	6.8	8.8

REAR DAMPER STIFFNESS AT WHEEL					
WISHBONE HOLE No.	No OF HOLES IN PISTON	OIL WEIGHT			
		10W	20W	30W	40W
3	1	12.4	19.1	29.5	38.0
	2	6.4	10.3	16.6	25.7
	3	4.8	7.7	13.8	17.4
	4	3.76	5.9	9.8	12.7
2	1	10.4	15.9	24.7	31.8
	2	5.4	8.6	13.9	21.5
	3	4.0	6.4	11.5	14.6
	4	3.1	4.9	8.2	10.6
1	1	8.6	13.2	20.4	26.3
	2	4.5	7.1	11.5	17.8
	3	3.3	5.3	9.5	12
	4	2.6	4.1	6.8	8.8

**NOTE : AMBIENT TEMPERATURE AFFECTS DAMPER STIFFNESS**

20w oil at 50° F (10° C) is approximately the same as 30w oil at 80° F (27° C)

See chart on page 21 for actual set ups. Use these tables for fine tuning.

Use these tables every time you change the suspension settings and record the settings and results for future use.

Experiment to find the settings that suit your driving style and the prevailing track conditions.

NOTE: All Schumacher springs are colour coded. The colour denotes the spring rate.

There are three sizes S (short), M (medium) L (long)

RATE	COLOUR
1.5	WHITE
2	YELLOW
3	GREY
4	BLUE
6	BLACK

- 11 ROLL CENTRE**  
Altering the rear top link position changes the roll centre. Different length tumbuckles need to be used depending on the hole chosen. Using a shorter link in one of the lower holes will increase steering response.

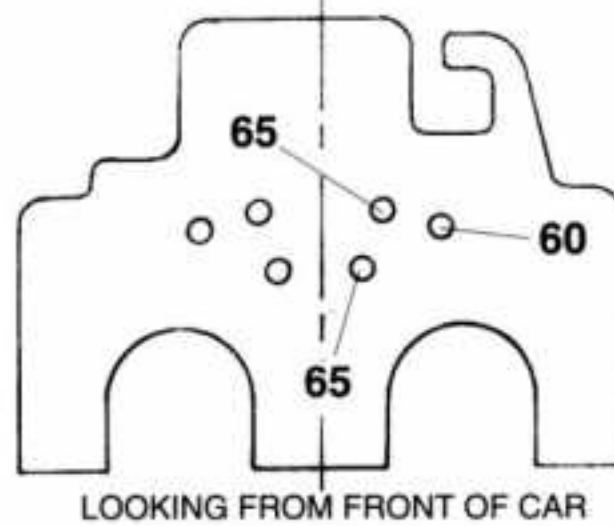

- 12 REAR ANTI-SQUAT**  
The car as standard runs 1.4 degrees anti-squat. This can be altered to 5 degree anti-squat by cutting or filing off the shaded sections shown. More anti-squat will reduce power understeer but may make rear of car more unpredictable.

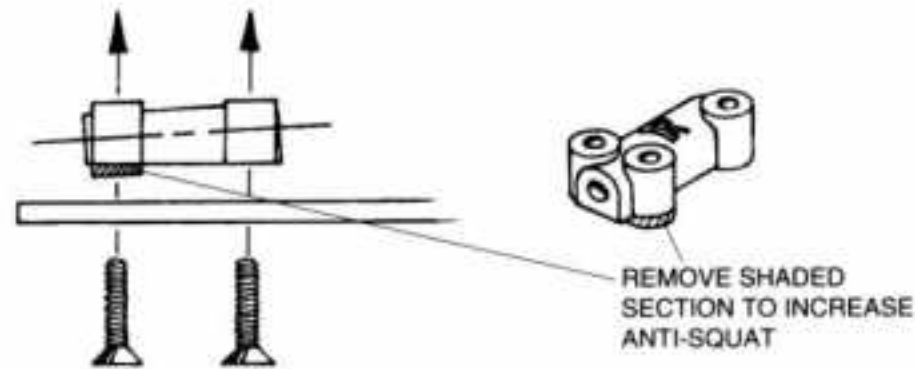

- 13 GEAR RATIO CHART - FOR 5 MINUTE RACE USING 1700 mAh NICADS**

PINION	SPUR GEAR	OVERALL RATIO	APPROX MOTOR WIND	PINION	SPUR GEAR	OVERALL RATIO	APPROX MOTOR WIND
28	86	6.14	27 T	20	86	8.60	
28	89	6.36		20	89	8.90	
27	86	6.37		20	92	9.20	15 T
27	89	6.59		20	95	9.50	
26	86	6.62		19	86	9.05	
26	89	6.85		19	89	9.37	
25	86	6.88		19	92	9.68	
25	89	7.12	20 T	19	95	10.00	14 T
25	92	7.36		18	89	9.89	
24	86	7.17		18	92	10.22	
24	89	7.42	19 T	18	95	10.55	
24	92	7.67		17	89	10.47	13 T
23	86	7.48		17	92	10.82	
23	89	7.74		17	95	11.18	
23	92	8.00	17 T	16	89	11.13	12 T
22	86	7.82		16	92	11.50	
22	89	8.09		16	95	11.86	
22	92	8.36	16 T	15	92	12.27	11 T
22	95	8.63	15 T	15	95	12.67	
21	86	8.19					
21	89	8.48					
21	92	8.76					
21	95	9.05					

GEAR SUM MAX - 117 TEETH  
GEAR SUM MIN - 105 TEETH  
GEAR BOX REDUCTION RATIO - 2:1

- 14 LUBRICATION**  
All bearings must be lubricated, especially during wet weather. Always remove bearings and clean after running in wet conditions. Plastic parts should NOT be lubricated. Only use silicone grease inside the differential and only use axle grease in the thrust races.

- 15 GENERAL**  
In general the car should understeer, - this means the front wheels slide more than the rear wheels during cornering. You can get this by cutting the spikes of the front tyres down. It helps to have two or three sets of front tyres with different levels of spikes to test for the best option.  
Run the lowest ride height that track conditions allow - a low car always corners better than a high car. Use the softest damper settings that stop the wheels from bouncing. It is easy to over damp the car and cause bouncing at high speed.

DRIVER :

MEETING:

TRACK:

DATE:

TRACK CONDITIONS:

## FRONT SUSPENSION

TOE-IN 0° +1° +2° +3° -1° -2° -3°  
 ACKERMANN 27mm 30mm

FRONT SHOCK BRACKET

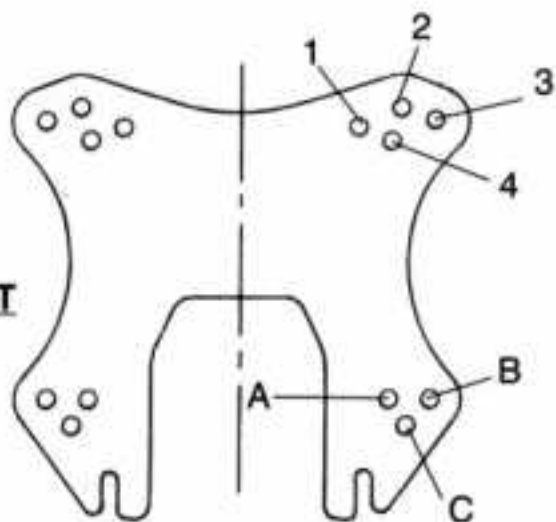

WISHBONES

STANDARD SWEPT

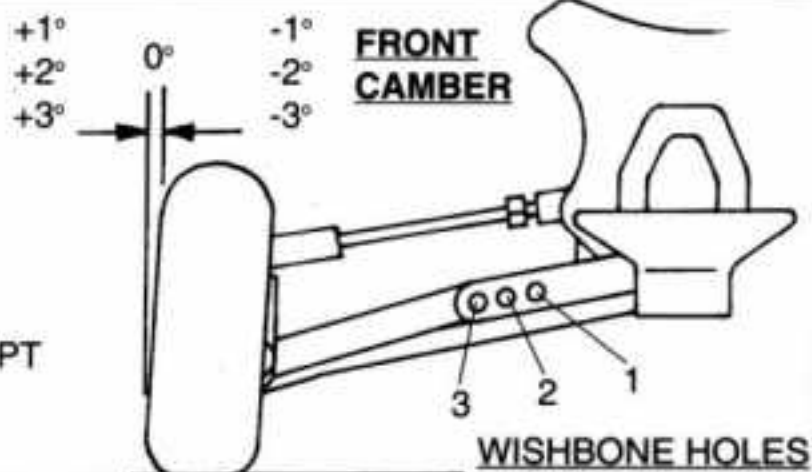

### SHOCKS - FRONT

OIL	10W	15W	20W	25W	30W	35W	40W	80W
HOLES OPEN	1	2	3	4				
VALVED	YES	NO						
SPRINGS	WHITE	YELLOW	GREY	BLUE	BLACK			
SPACERS								mm

## REAR SUSPENSION

TOE-IN INSERT -1° -2° 0° +1° +2° (ACTUAL TOE-IN = \_\_\_\_\_, 0° insert = 3° actual toe-in)  
 OUTBOARD PIVOT PIN HIGH LOW  
 ANTISQUAT 1.4° 5°

REAR CAMBER

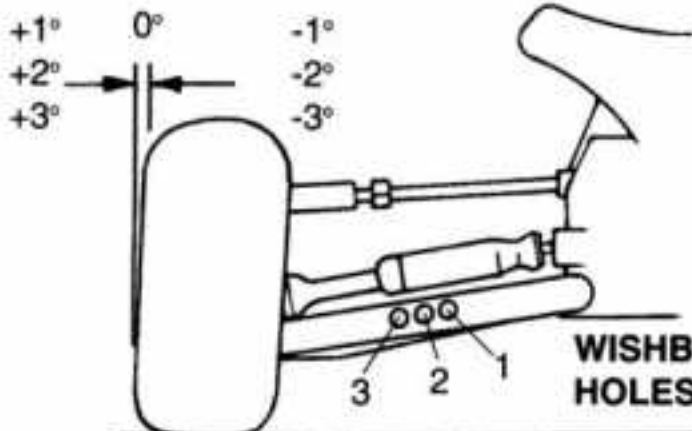

REAR TOP LINK

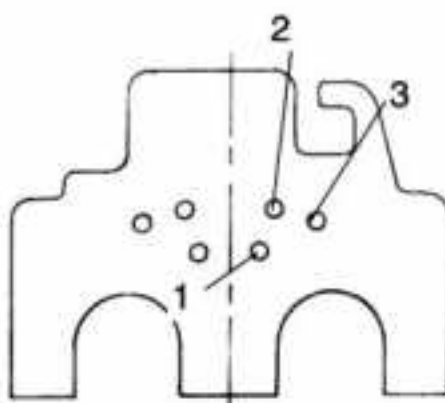

REAR SHOCK BRACKET

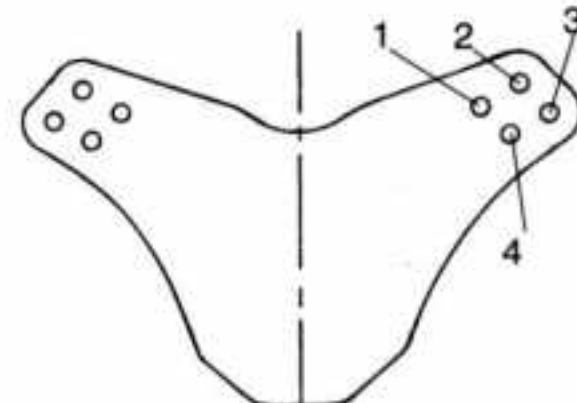

### SHOCKS - REAR

OIL	10W	15W	20W	25W	30W	35W	40W	80W
HOLES OPEN	1	2	3	4				
VALVED	YES	NO						
SPRINGS	WHITE	YELLOW	GREY	BLUE	BLACK			
SPACERS								mm

WHEELBASE

← REAR OF CAR



## TRANSMISSION

SPUR GEAR 89T 92T 95T 98T  
 PINION 15T 16T 17T 18T 19T 20T 21T 22T  
 SLIPPER (SLIP DIST) 0.25m 0.50m 0.75m  
 DRIVESHAFTS ROLLER PLAIN

MOTOR TYPE / WIND .....

RECEIVER .....

CELLS - TYPE .....

SERVO .....

SPEED CONTROLLER .....

## TYRES

FRONT U.....  
 REAR U.....

FOAMS - YES/NO  
 FOAMS - YES/NO

REAR HEX DRIVES - WIDE NARROW

CHASSIS LAYOUT .....