

PRO-CAT

Advancing the Sport - Improving the Breed

INSTRUCTION MANUAL

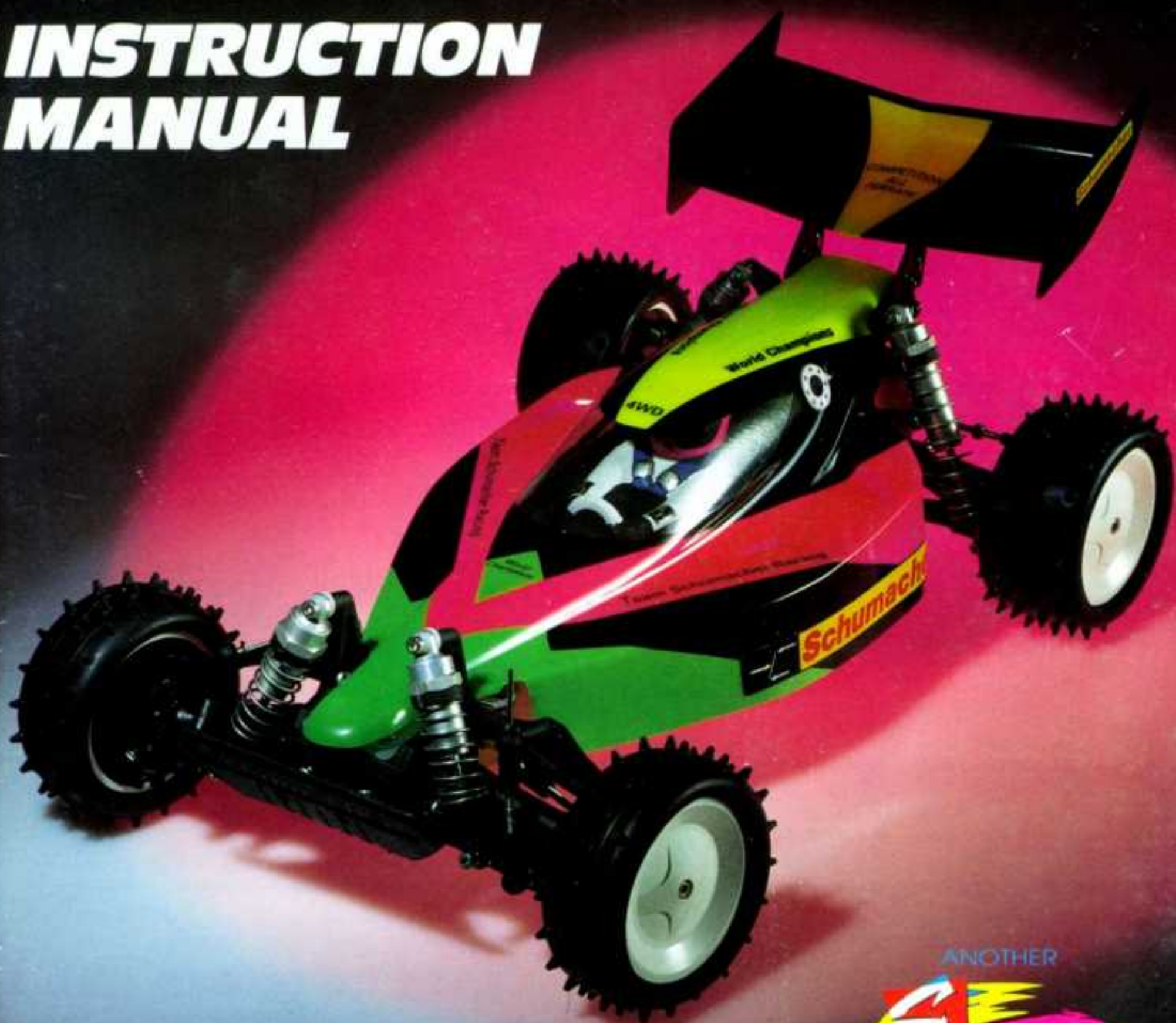

ANOTHER



RACING PRODUCT FROM

Schumacher

Performance and technology that YOU CAN BUY!

SPEED SECRETS

GET TO "GRIPS" WITH SUCCESS

WHEN IT COMES TO 'STATE OF THE ART' RACE WINNING TYRES, THE SERIES OF SCHUMACHER CAT TYRES IS THE STANDARD BY WHICH ALL OTHERS ARE JUDGED.

WHETHER YOU ARE RUNNING 2WD OR 4WD THE CAT TYRES OFFER THE HANDLING AND PERFORMANCE THAT UNTIL NOW HAS NOT BEEN AVAILABLE. TO DESIGN THESE TYRES IT TOOK MORE THAN JUST DRAWING A SPIKE PATTERN ON A PIECE OF PAPER, BECAUSE THAT IS NOT THE ONLY THING THAT CONTRIBUTES TO A TYRES PERFORMANCE. THE RUBBER COMPOUND IS ALL IMPORTANT IN A HIGH PERFORMANCE TYRE. SCHUMACHER DESIGNERS SPENT OVER A YEAR TESTING AND CONSULTING WITH ENGINEERS TO DEVELOP JUST THE RIGHT COMBINATION OF FLEX, GRIP AND WEAR TO PRODUCE THE BEST TYRE IN OFF-ROAD RACING!



T658
T659
T660
T661

T662
T663
T664
T665

T650
T651
T652
T653

T672
T673
T674
T675

T670
T671

T654
T655

T668
T669

T666
T667



T650T	REAR	TYRES	4x20	SPIKE	(SOFT)
T651U	REAR	TYRES	4x20	SPIKE	(HARD)
T652V	FRONT	TYRES	3x20	SPIKE	(SOFT)
T653W	FRONT	TYRES	3x20	SPIKE	(HARD)
T662F	REAR	TYRES	6x20	BLOCKTREAD	(SOFT)
T663G	REAR	TYRES	6x20	BLOCKTREAD	(HARD)
T664H	FRONT	TYRES	4x20	BLOCKTREAD	(SOFT)
T665I	FRONT	TYRES	4x20	BLOCKTREAD	(HARD)
T654X	FRONT	TYRES	2x20	STUD	(SOFT)
T655Y	FRONT	TYRES	2x20	STUD	(HARD)
T670N	FRONT	TYRES	SPONGE T&G ON WHEEL		
T671O	REAR	TYRES	SPONGE T&G ON WHEEL		

T677U	FRONT	TYRES		RIB	(HARD)
T676T	FRONT	TYRES		RIB	(SOFT)
T672P	REAR	TYRES	4x20	CUT SPIKE	(SOFT)
T673Q	REAR	TYRES	4x20	CUT SPIKE	(HARD)
T674R	FRONT	TYRES	3x20	CUT SPIKE	(SOFT)
T675S	FRONT	TYRES	3x20	CUT SPIKE	(HARD)
T658B	REAR	TYRES	5x24	MINISPIKE	(SOFT)
T659C	REAR	TYRES	5x24	MINISPIKE	(HARD)
T660D	FRONT	TYRES	4x24	MINISPIKE	(SOFT)
T661E	FRONT	TYRES	4x24	MINISPIKE	(HARD)
T668L	FRONT	TYRES	1x20	RIB SPIKE	(SOFT)
T669M	FRONT	TYRES	1x20	RIB SPIKE	(HARD)
T666J	REAR	TYRES	6x20	CUT SPIKE	(SOFT)
T667K	REAR	TYRES	6x20	CUT SPIKE	(HARD)

Schumacher

Performance and technology that **YOU CAN BUY!**

SCHUMACHER

PRO-CAT

INTRODUCTION

Congratulations on choosing the PRO-CAT.

We have spent a great amount of time developing this car to give you reliability and performance.

It contains the latest in off road technology with the highest quality materials and ease of construction.

The PRO-CAT has been designed for all levels of competitor to be the ultimate in 4WD 1/10 scale off road racers.

We hope that you have fun and enjoy your racing.

Cecil Schumacher

IMPORTANT SAFETY NOTES

1. Select an area for assembly that is away from reach of small children. the parts are small and can be swallowed by children causing choking and possible internal injuries.
2. Shock fluids, grease and adhesives should be kept out of childrens reach. They are not toxic, but were not intended for human consumption.
3. Exercise care when using any hand tools, sharp instruments and power tools during construction.
4. Carefully read all manufacturers warnings and cautions for any glues or paints that may be used for assembly purposes.



Places to put threadlock. (It will prevent the screws and nuts vibrating loose.)



Points where silicone grease (MS 1 or equivalent) should be applied. (It will reduce friction and assure smooth movement.)



Points where oil should be applied (Light machine oil, 3 in 1 or similar.)

MISSING OR DEFECTIVE PARTS

In the unlikely event of problems with your new kit you should contact the model shop where purchased quoting part number, bag number and batch number for both the bag and the kit.

SCHUMACHER RACING PRODUCTS

Hanson Business Park · 71-73 Tenter Road · Moulton Park · Northampton · NN3 1AX

THINGS NEEDED BESIDES THE KIT

(2 Channel Radio System)

Two types of radio control sets are on the market, the stick type and the steering wheel type. Choose which ever you like.

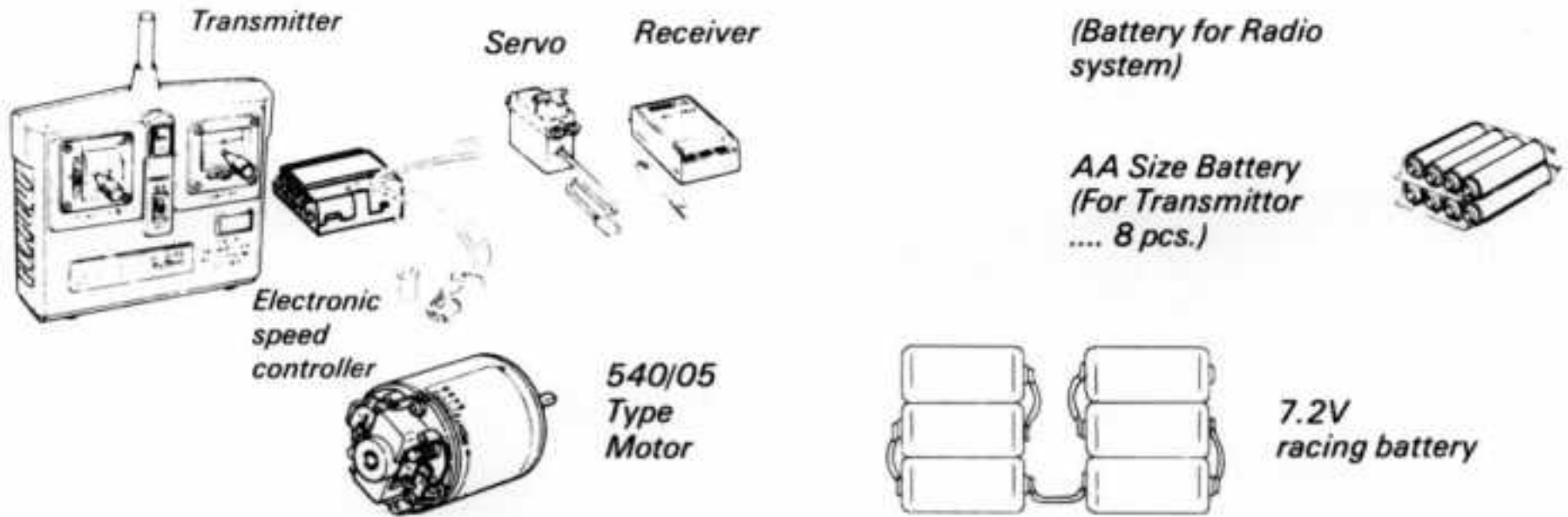

Do not use excessive force when tightening the self-tapping screws, or you may strip the thread in the plastic. It is recommended to stop tightening it when the threaded part on the screw goes into the plastic part and you feel some resistance from the tightening.

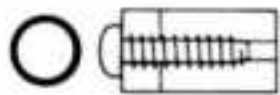

Good

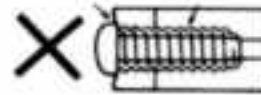

Over tighten and may strip the thread in the plastic

- CH HD Cheese head
- CSK HD Countersunk head
- PAN HD Self tap thread
- CAP HD Cap head

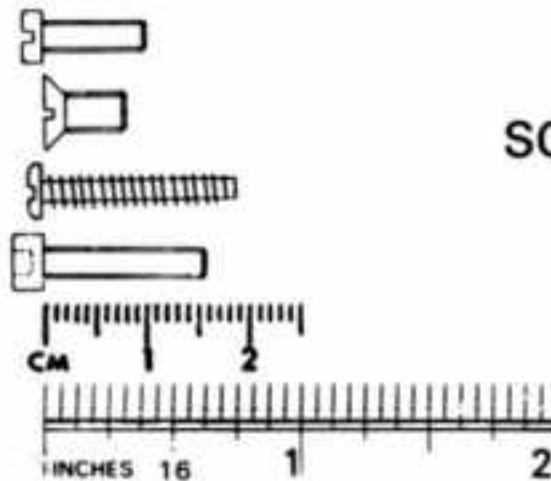

SCREW IDENTIFICATION CHART

TOOLS REQUIRED FOR ASSEMBLY

- Screwdriver
- Spanner (wrench) 5.5mm A/F
- Spanner (wrench) 1/4 A/F
- Drill (for holes in bodyshell & covers)
- Pliers
- Sharp Knife
- File
- Pointed nose pliers or cutters

MATERIALS REQUIRED

(not in kit)

- Threadlock
- Light oil for shock absorbers
- Polycarbonate paint for bodyshell
- Motor, batteries, radio control equipment
- speed controller

TRANSMISSION ASSEMBLY

Bag No. T580

PARTS USED

- T072 Cover Plate
- T073 Motor Plate
- T081 Rear Bearing Housing - Eccentric
- T082 Diff Bearing Housing - Open
- T083 Diff Bearing Housing - Closed
- A301 Self Tap Screw No.2 x 3/16" Pan Hd.

Step 1 - SIDE PLATES

Fit the T081 eccentric bearing housings and the open and closed bearing housings T082/T083 to the side plates using A301 self tap screws. At this stage use only two screws in the eccentric bearing housings as these may be adjusted later for the correct belt tension. Note the angular position of the eccentric bearing tabs which should be the same on both sides.

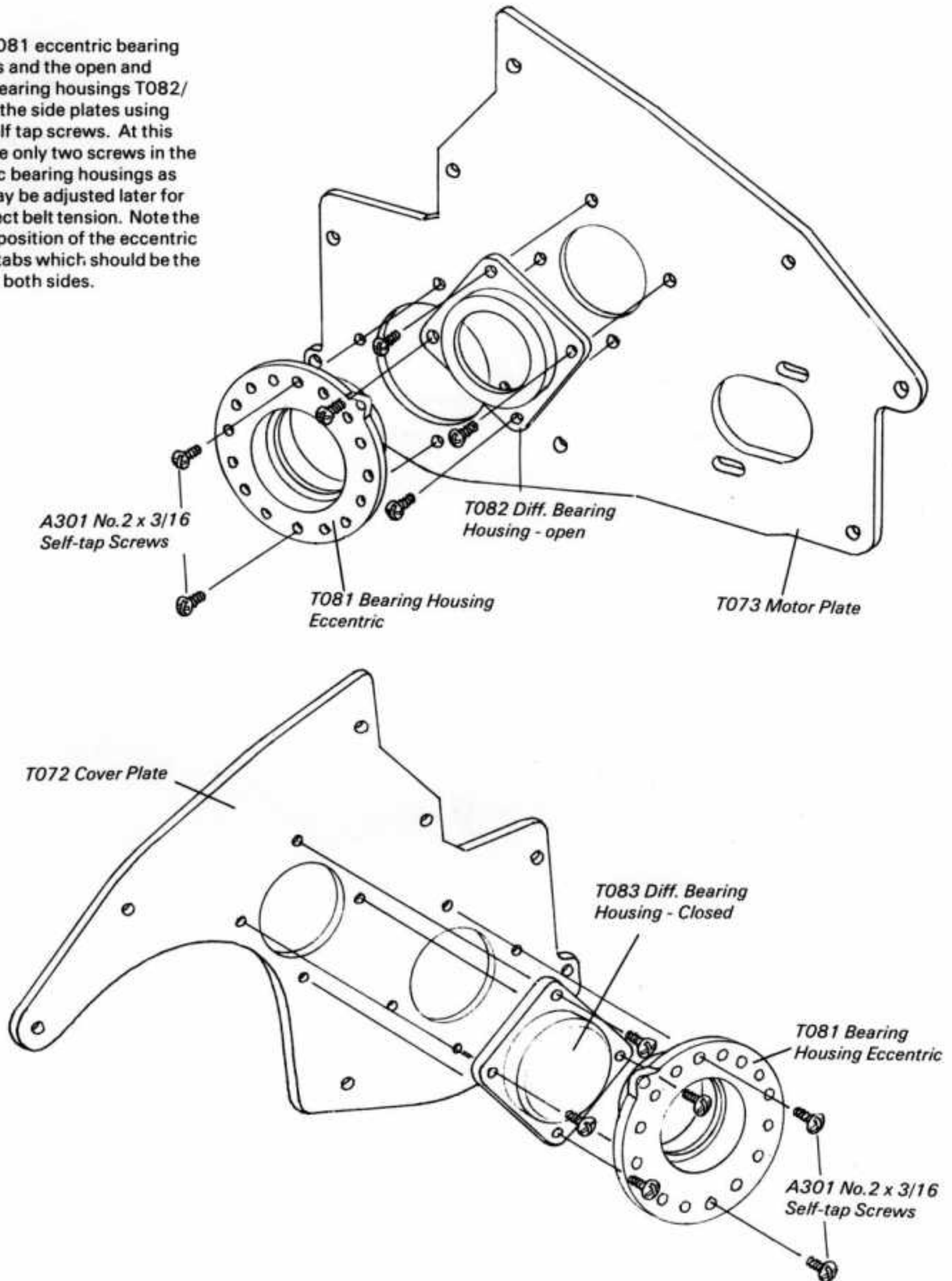

TRANSMISSION ASSEMBLY

Bag No. T580

PARTS USED

- T277 Layshaft
- T279 Flange (x2)
- T278 21T Pulley (x2)
- A405 Pin 2.0 x 7.8mm (x2)
- T070 Rear Transmission Housing - Inner
- A533 Ball bearing
- A323 Self Tap Screw No.4 x 3/8" Pan Hd.

Step 2 - LAYSHAFT

A) Fit the two A405 pins into the T277 layshaft and slide a 21T pulley T278 onto each and push towards each other so that they fully lock together. Push T279 flanges onto each end of the layshaft so that the short diameters locate inside the 21T pulleys.

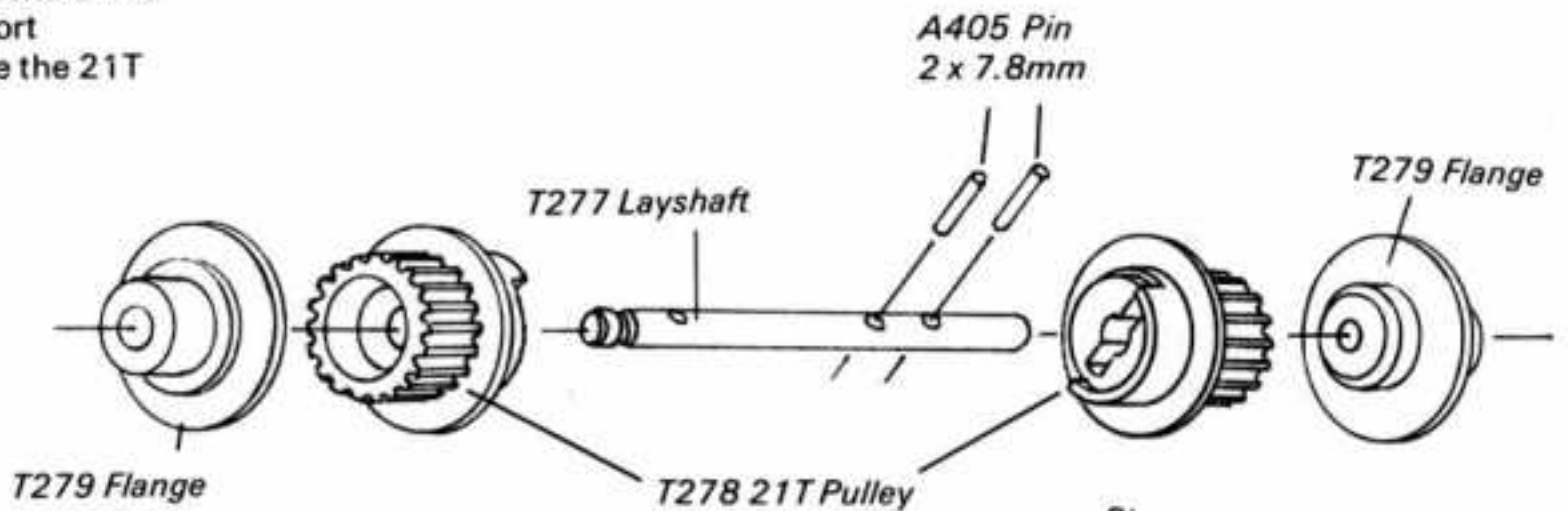

B) Fit an A533 ball bearing into the open bearing housing in T073 motor plate with the black face towards the outside of the plate. Insert the layshaft assembly into the ball bearing as shown. Fit the T070 inner transmission housing using two A323 self-tap screws as shown.

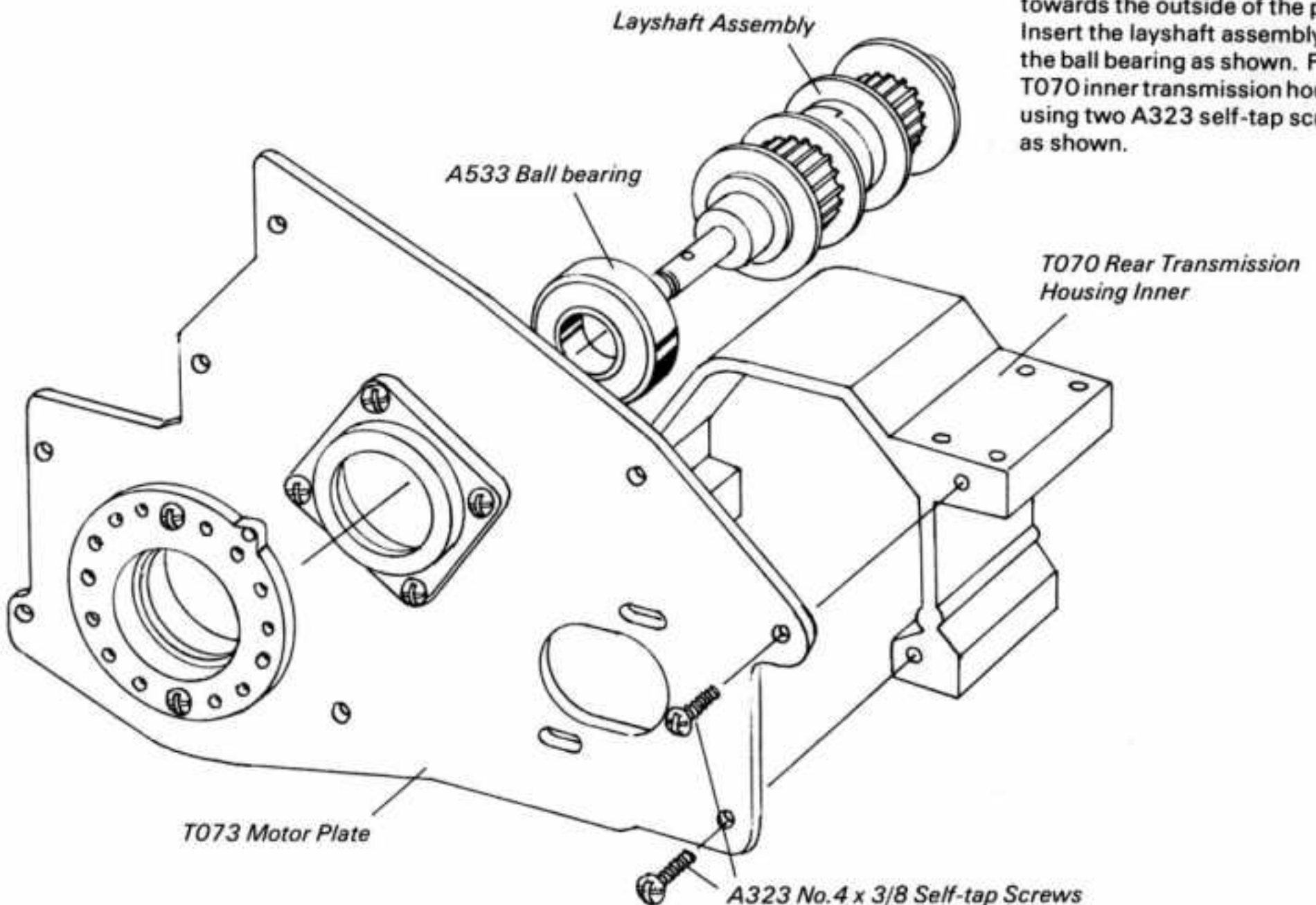

TRANSMISSION ASSEMBLY

Bag No. T580

PARTS USED

- T031 Rear Hub
- A051 Nyloc Nut
- A154 Disc Spring 1/8"
- T084 Rear Axle
- A520 Thrust Race Assembly
- A533 Ball bearing
- A220 Thrust Washer
- T173 Centre Pulley 51T
- T174 Drum Diff Side Pulley 51T
- A500 3mm Steel Balls
- A305 Self Tap Screws No.2 x 1/2" Pan Hd.
- T118 Washer Carrier
- T243 Friction Paper

Step 3 - REAR DRUM DIFFERENTIAL

A) Take one T031 rear hub and using a M3 x 20 steel screw, steel washer and M3 nut, pull an A051 nyloc nut firmly into the shaped recess as shown. Then remove the screw.

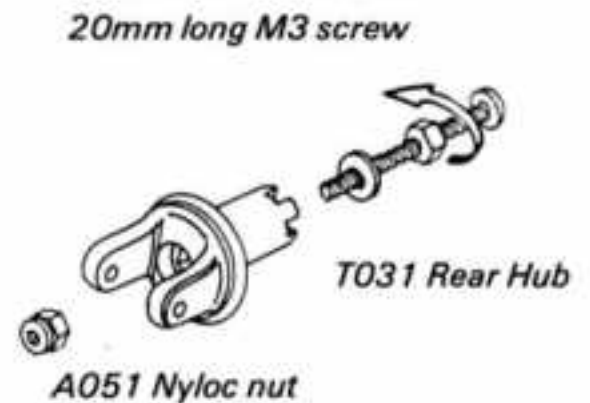

A220 Steel thrust washer

B) Using epoxy or superglue fix the T245 friction paper to the A220 steel thrust washer with the smooth surface towards the steel washer. Make sure both washers are concentric and press between two flat surfaces whilst adhesive is curing.

T243 Friction paper

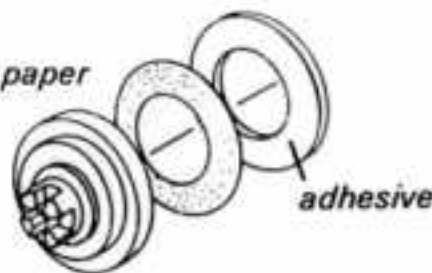

T118 Washer carrier

C) Fit the two T174 drum differential side pulleys (51T) to either side of the T173 centre pulley using six A305 self-tap screws. Make sure that the small peg on each side of the pulleys engages in the recess in the centre pulley. This ensures that all the teeth are in line. Insert 14 steel balls (3mm) into the cavities in the centre pulley and lightly lubricate with silicone grease.

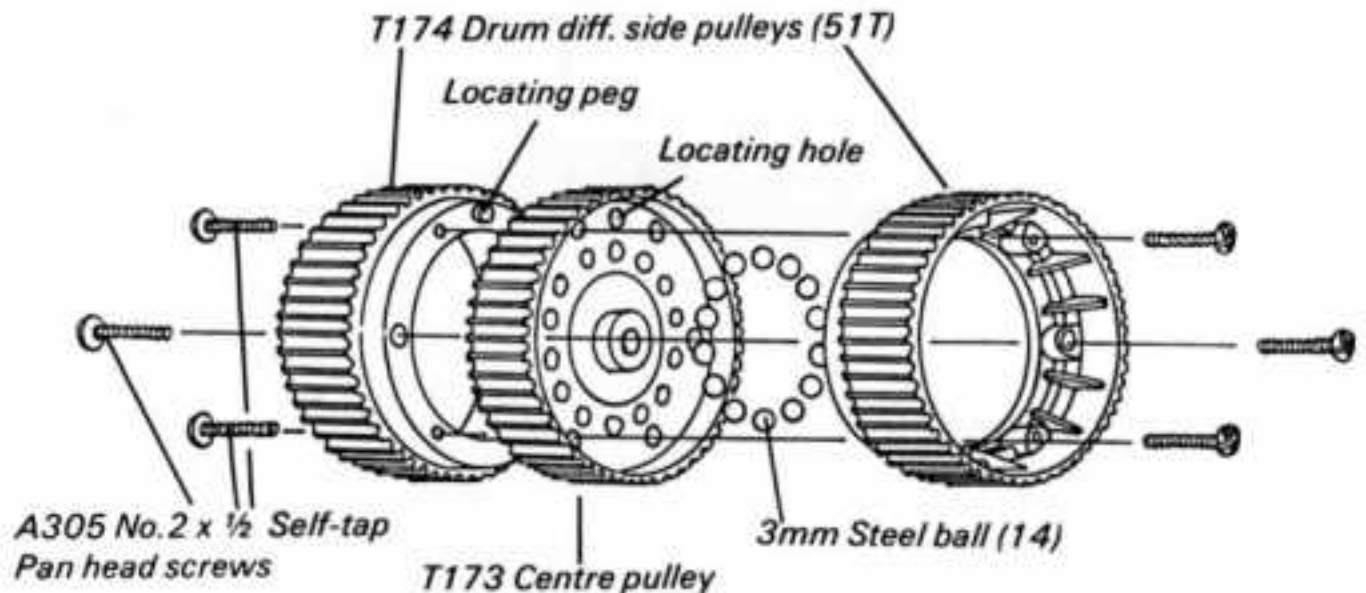

D) Ensure drum differential moves feely on T084 axle, deburr holes in 51T centre pulley if required. Assemble differential parts onto the T084 rear axle as shown. Make sure the washer carriers and the hubs correctly engage and that the thrust washers correctly locate over the

raised centre section of the washer carriers. Screw up the axle until clearance is removed and washers are gently clamped. While holding both hubs, force the pulley to turn round a few times. Apply a little more tension so that pulleys can only be made to turn with some difficulty using

finger pressure only. Differential action should now be free and smooth, final adjustment of the differential will be made when all parts are installed.

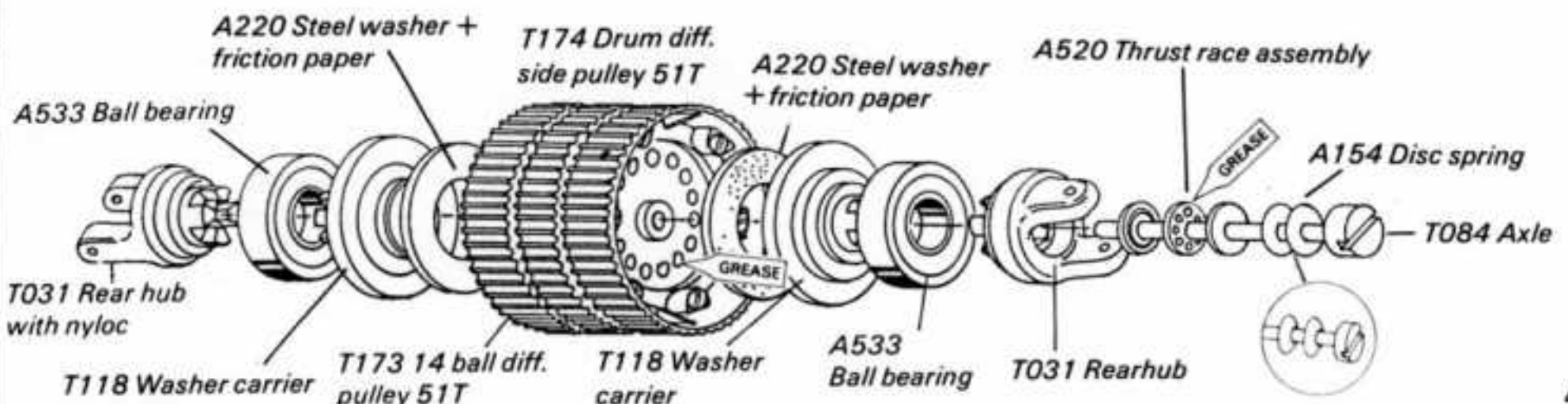

TRANSMISSION ASSEMBLY

Bag No. T580

PARTS USED

- T108 Universal Joints
 T028 Drive Shaft - Outer
 T027 Drive Shaft - Inner
 T030 Wheel Hub
 T131 Universal Joint Assembly Tool

Step 4 - UNIVERSAL JOINTS

All T030 wheel hubs and drive shafts need to be prepared for assembly later. Pull one nyloc nut into the recess of all four T030 wheel hubs by the same method as shown in Step 3A.

A) Refer to the illustration and fit a T108 universal joint assembly tool before use. First time assembly is made easier by warming the moulded parts in hot water. Once the technique is acquired joint assembly becomes a simple task.

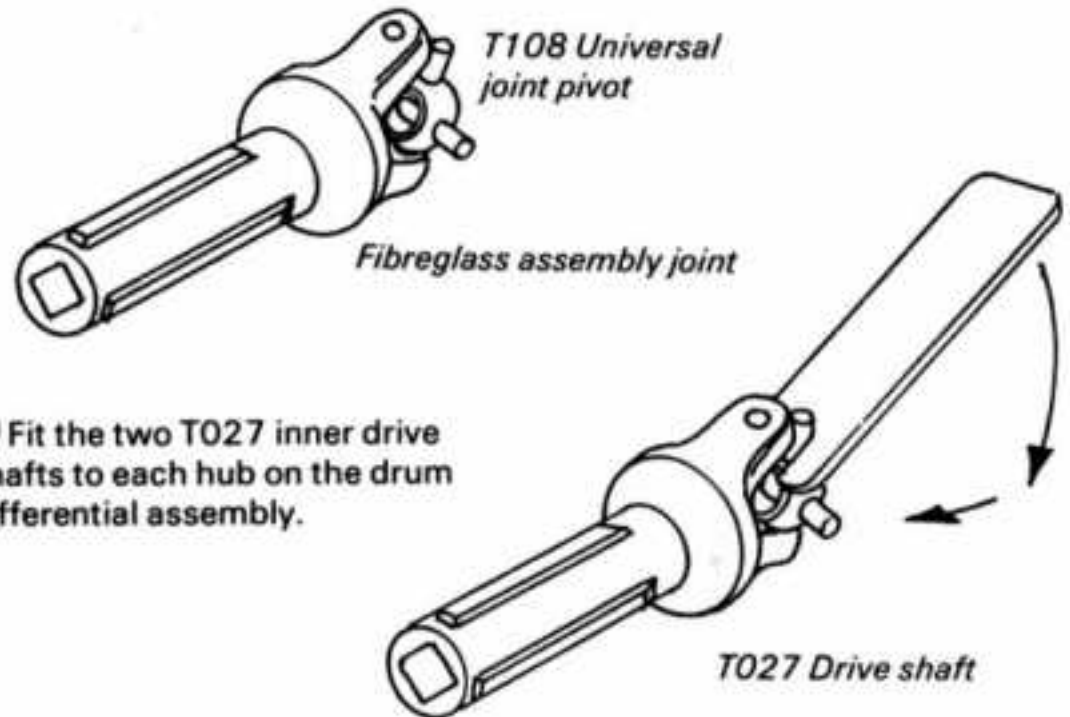

B) Fit the two T027 inner drive shafts to each hub on the drum differential assembly.

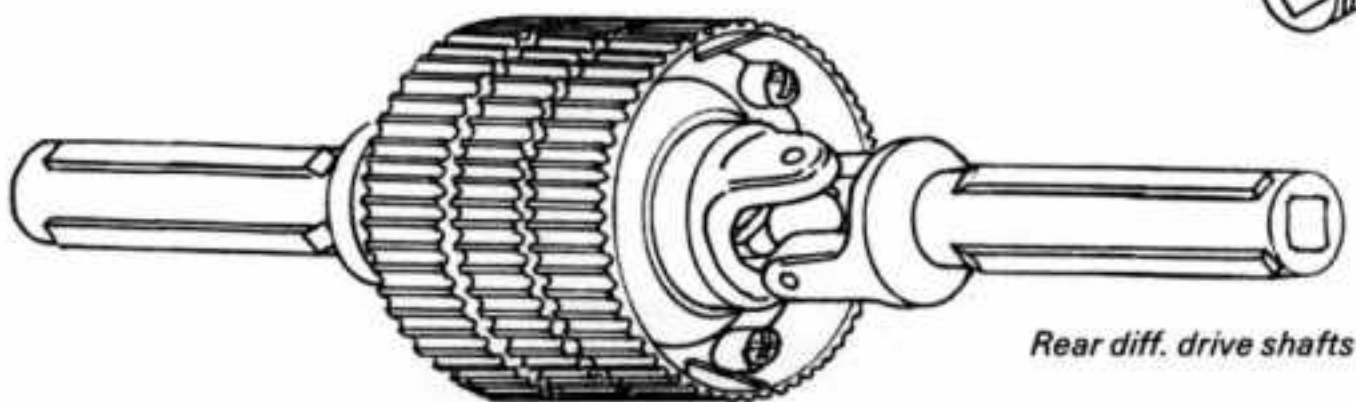
**PARTS USED**

- T129 Short Drive Belt
 A323 Self Tap Screw No.4 x 3/8" Pan Hd.
 T152 Long Drive Belt
 T147 Upper Chassis Plate
 T288 Lower Chassis Plate
 A533 Ball bearing

Step 5 - DRIVE BELTS

A) Insert an A533 ball bearing into the closed bearing housing in T072 cover plate. Insert the drum differential assembly into the eccentric bearing housing, as shown, the screwhead of the axle should be on the right side of the car. Fit the T129 short drive belts over the two 21T layshaft pulleys and the two 51T side pulleys. Add the T072 cover plate and retain with one A323 self tap screw.

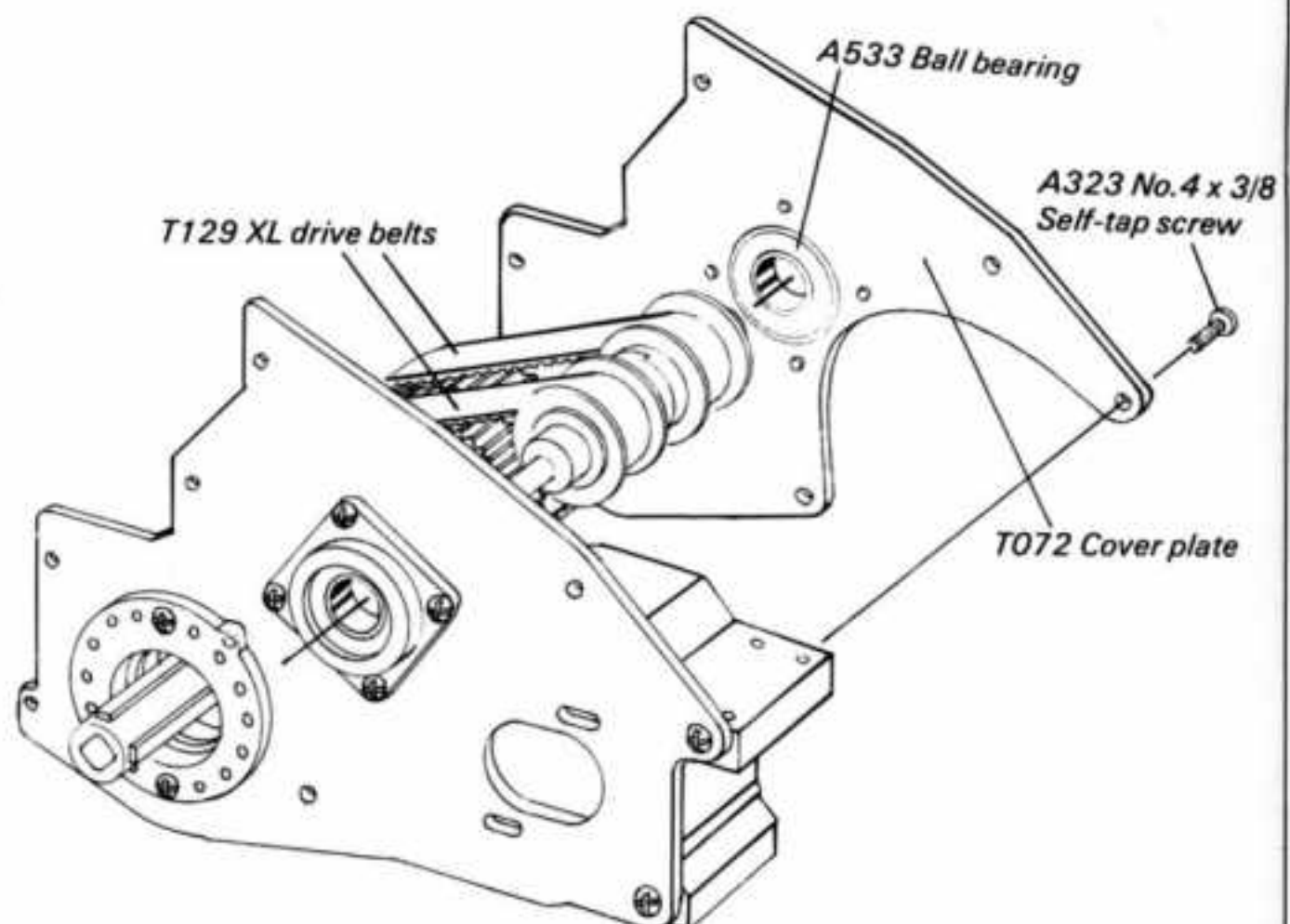

PARTS USED

- T108 Universal Joints
- T028 Drive Shaft - Outer
- T027 Drive Shaft - Inner
- T030 Wheel Hub
- T131 Universal Joint Assembly Tool

TRANSMISSION ASSEMBLY

Bag No. T580

B) Loop the T152 long drive belt over the centre 51T pulley and then fit the T147 upper chassis using two A323 self tap screws. Fit the T288 lower chassis using four A323 self tap screws. Make sure it is the right way up!

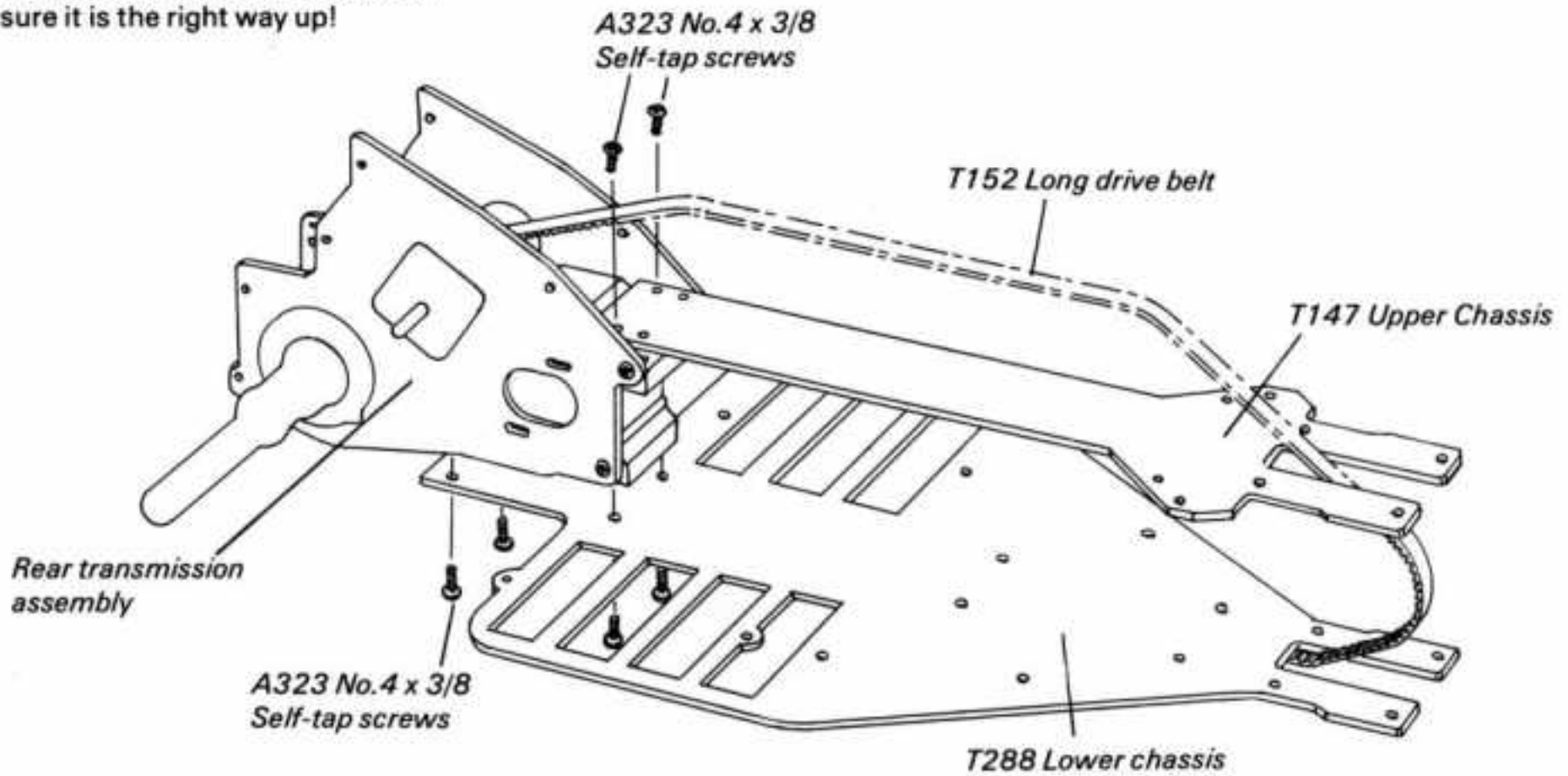

PARTS USED

- T295 Nicad Strap & Post
- A323 No. 4 x 3/8" Self Tap Screws

Step 6 - NICAD CLAMPS

A) Fit the two nicad straps to the two rear most holes in the lower chassis using two A323 self-tap screws. Fit the two nicad posts to the lower chassis using two more A323 self-tap screws. The nicads are strapped in by flexing the strap over and 'Click' fitting to the post. The nicad post on the righthand side of the car can be repositioned and the strap will hold four cells. The boss protruding into the fourth cell hole in the chassis must be filed away.

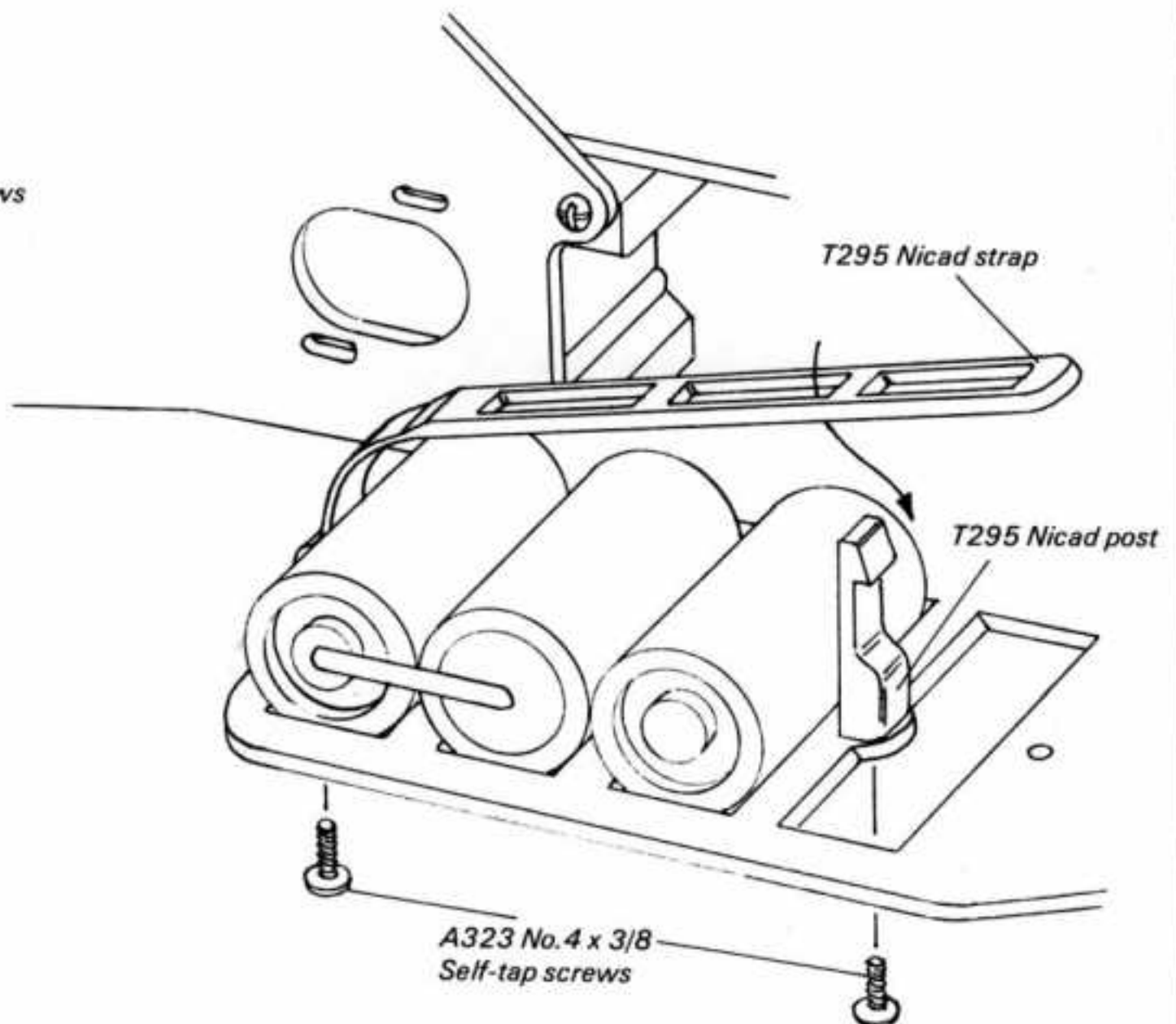

TRANSMISSION ASSEMBLY

Bag No. T580

PARTS USED

- T031 Hub
- T173 Centre Pulley
- T118 Washer Carrier
- A220 Thrust Washer
- T084 Axle
- A520 Thrust Race Assembly
- T080 Flange
- T055 Front Transmission Housings
- A324 Self Tap Screw No.4 x 1/2 Pan Hd.
- A532 Ball bearing Flanged
- T243 Friction Paper
- A154 Disc Springs
- A500 3mm Balls
- T078 Inner Drive Shaft
- T108 Universal Joint

Step 7 - FRONT DIFFERENTIAL

A) Pull a nyloc nut into a T031 rear hub as shown in Step 3A. Fix the T245 friction paper to the A220 steel thrust washer as shown in Step 3B. Assemble the front differential parts as shown in the following order: T084 axle, A154 disc spring (2 off), A520 thrust race assembly, T031 hub (without nyloc nut), T080 flange, T055 front transmission housing, A532 flanged ball bearing, T118 washer carrier, A220 steel washer with friction paper towards the washer carrier, T173 centre pulley (with 14 steel balls -3mm, lightly lubricated with silicone grease), A220 steel washer, T118 washer carrier, A532 flanged ball bearing, T055 front transmission housing, T080 flange and finally T031 rear hub with nyloc nut fitted. Make sure the T118 washer carriers and the T031 hubs correctly engage and that the steel thrust washers correctly locate on the washer carriers. Screw up the axle until clearance is removed and washers are gently clamped. While holding both hubs, force the pulley to turn round a few times. Apply a little more tension such that the pulleys can only be made to turn with some difficulty using finger pressure only. Differential action should now be free and smooth (final adjustment of the differential will be made when the car is fully assembled).

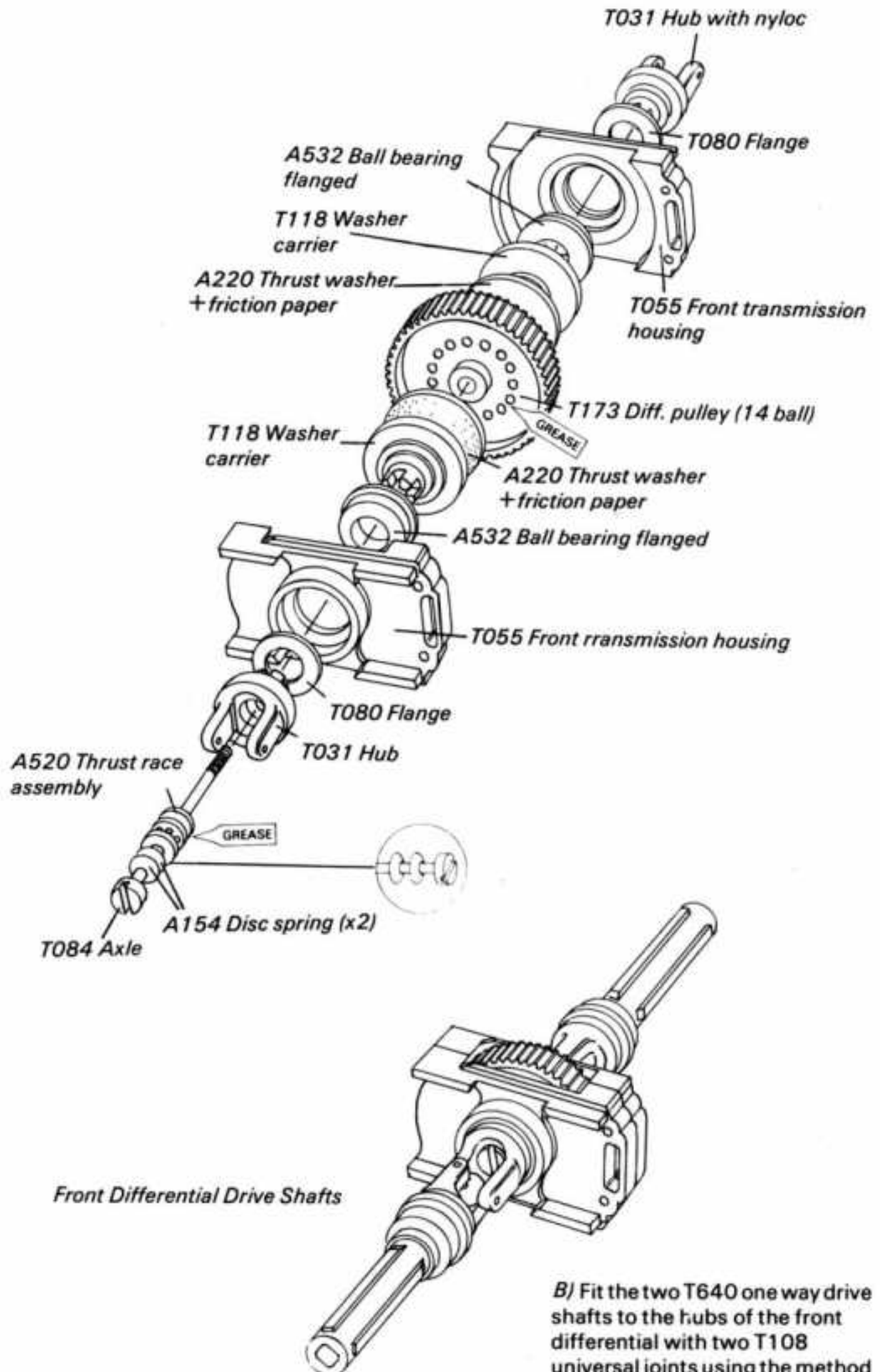

B) Fit the two T640 one way drive shafts to the hubs of the front differential with two T108 universal joints using the method shown in Step 4A. The one way drive shafts should be fitted so that they both freewheel on a forward direction.

TRANSMISSION ASSEMBLY

Bag No. T580

PARTS USED

- A324 Self Tap Screw No.4 x 1/2" Pan Hd.
- T056 Front suspension brackets
- T057 Front suspension brackets
- A336 Self Tap Screws No.4 x 3/4" Counter Sunk
- T292 Tensioning Bar
- A323 Self Tap Screw No.4 x 3/8" Pan Hd.

Step 8 - FRONT TRANSMISSION

A) Rotate the front transmission housings at 90 degrees to each other and fit the long drive belt between them, realign the housings and screw together using two A324 self tap screws. (The screw head of the axle should be on the righthand side of the car). Seat the front transmission assembly into the grooves in the top and bottom chassis plates. Fit the T056/T057 suspension brackets as shown either side of the front transmission housings. These brackets clamp the front transmission housings to the upper and lower chassis plates and also provide the pivots for the front suspension mountings. Use four A324 screws in the top and four A336 countersunk screws in the

bottom to clamp the assembly together. These screws will have to be removed and replaced later to fit the top belt cover, front bumper and undertray. Insert the T292 tensioning bar into the transmission housings as shown with the lugs to the front of the car. Screw in two A323 self tap screws so that they just rest against the uprights of the suspension brackets. These will be adjusted later to obtain the correct tension in the long drive belt.

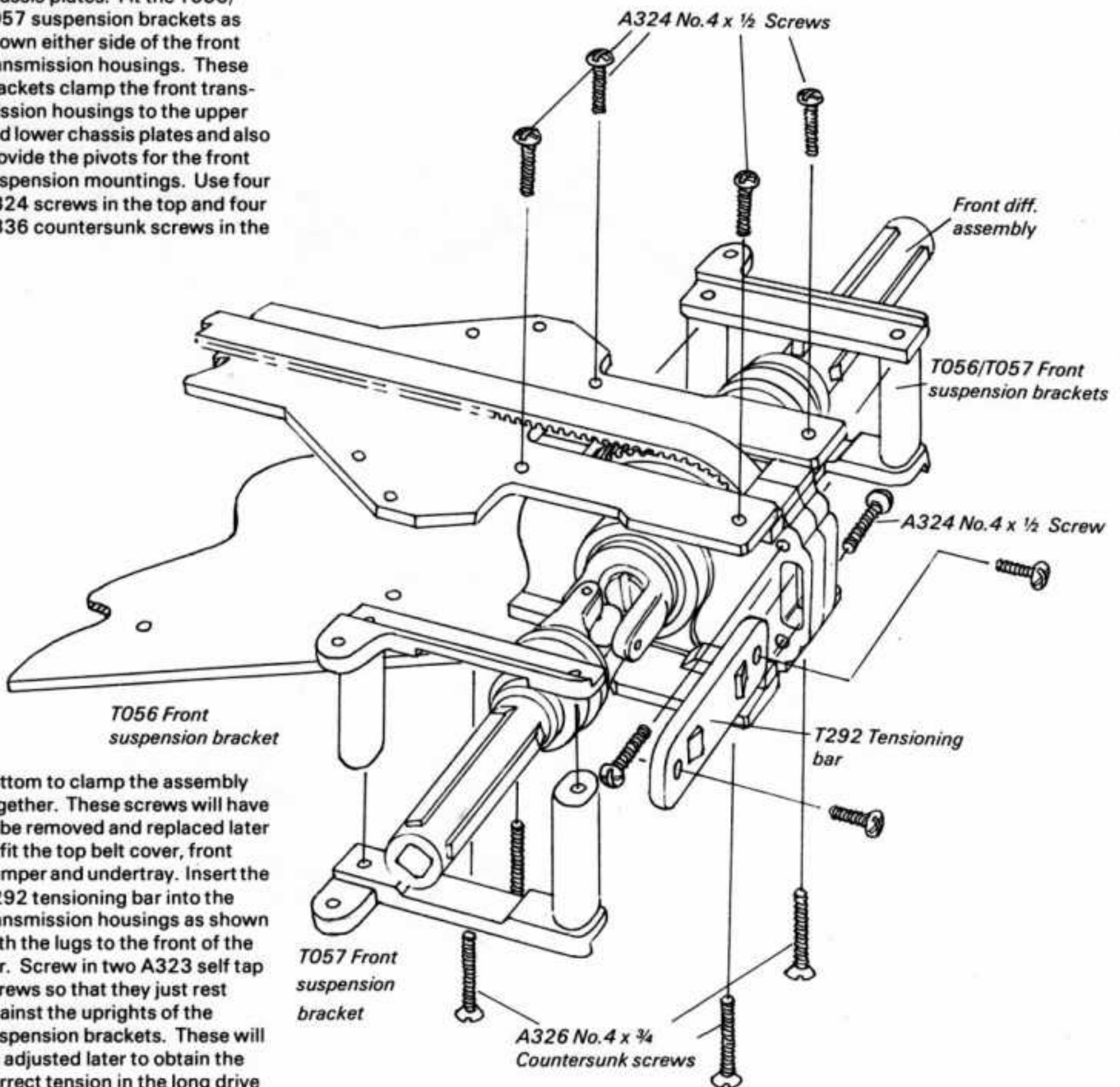

PARTS USED

A323 Self Tap Screw No.4 x 3/8" Pan Hd.

T293 Rear Transmission Housing - Outer

Step 9 - REAR BELT TENSION

TRANSMISSION ASSEMBLY

Bag No. T580

A) With all the tension removed from the long drive belt the tension of the short drive belts can be checked. There should be a 1mm or 2mm deflection. If the tension is not correct, remove the screws retaining the T081 eccentric bearing housing and rotate clockwise on the right hand side and anticlockwise on the left hand side, to obtain the correct tension. It is important to note that the tabs on the eccentric bearing housings should be rotated towards the bottom of the plate to increase the tension. If rotated towards the top, the short drive belts can rub against the inside of the T293 rear outer transmission housing. Recheck the belt tension after all the screws are fully tightened.

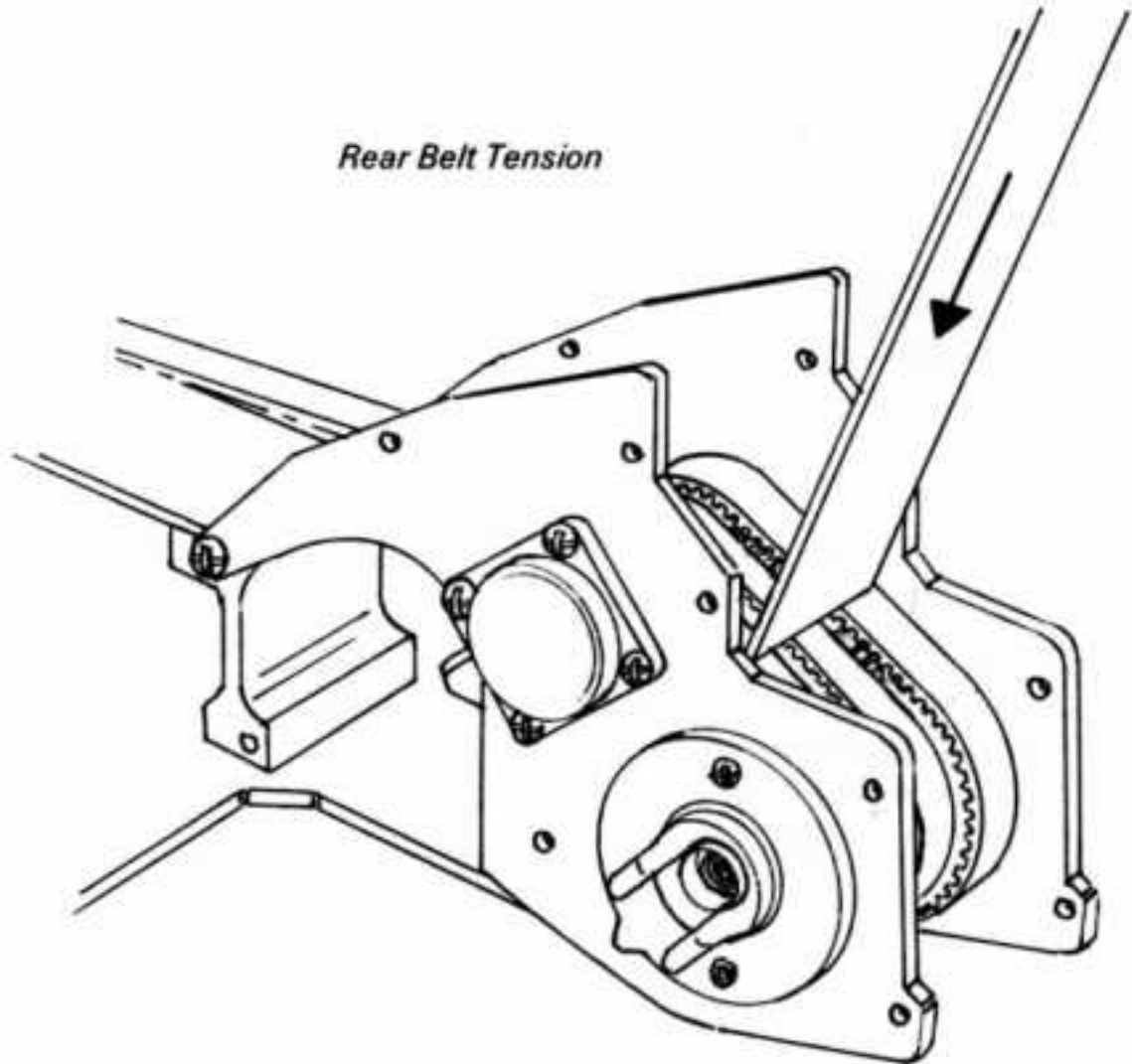

Rear transmission housing

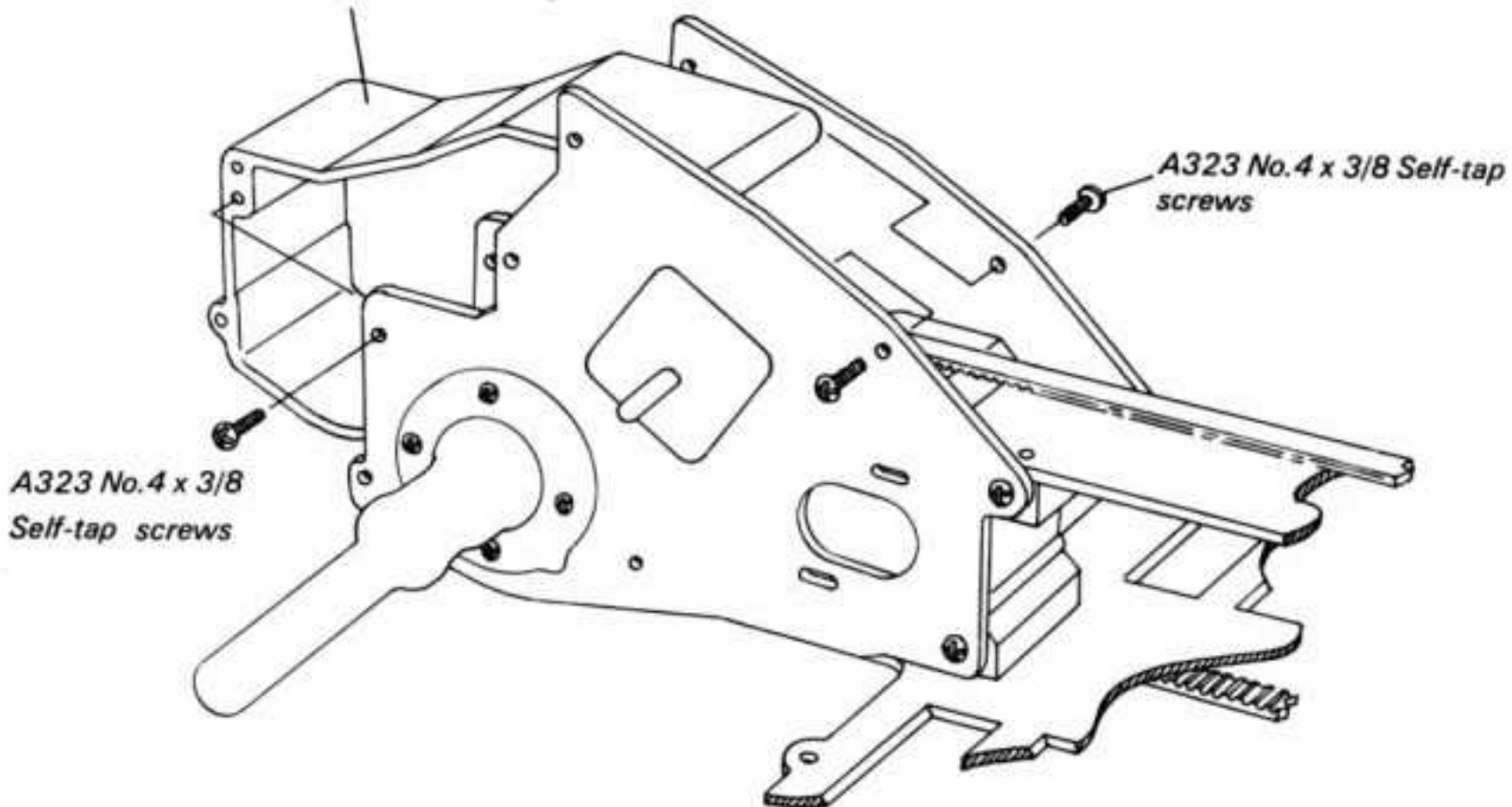

B) Fit the T293 outer transmission housing using four A323 self tap screws.

PARTS USED

- T076 Mounting Bracket
- A323 Screw Self Tap No.4 x 3/8" Pan Hd.
- T275 Rear Shock & Wing Mount
- T263 Wing Bracket
- T273 Rear Suspension Bracket
- T276 Rear Wishbone Pivot Brackets
- T238 Rose Joint - Socket
- T239 Rose Joint - Ball
- A327 Self Tap Screw No.4 x 1" Pan Hd.
- A412 Pin 2.0 x 54mm
- A411 Pin 2.0 x 40mm
- T199 Rear Hub Carrier
- T268 Rear Wishbone
- A093 Stud M3 x 35
- A030 M3 x 10 Pan Hd.
- A325 Screw Self Tap No.4 x 5/8"Pan Hd.

Step 1

A/ Fit two T076 mounting brackets between the rear transmission side plates and retain with A325 self tap screws. Note that the top bracket has the side plate holes below the two other holes, the bottom bracket has the side plate holes above the other two holes. Fit two T263 wing brackets to the T275 rear shock and wing mount as shown using two A323 self tap screws. Fit the T275 rear shock & wing mount assembly to the top mounting bracket using two A323 self tap screws. Fit the T273 rear suspension bracket to the bottom mounting bracket using two A325 self tap screws.

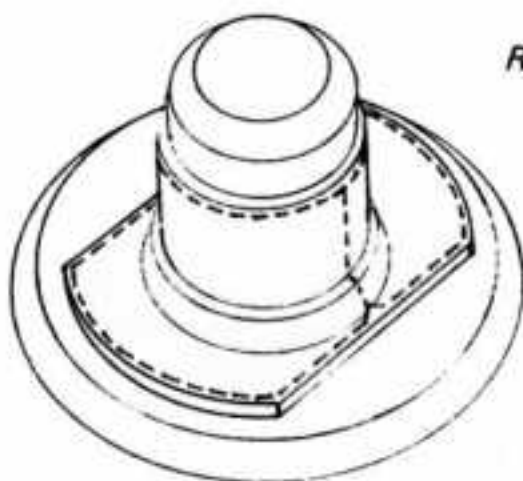
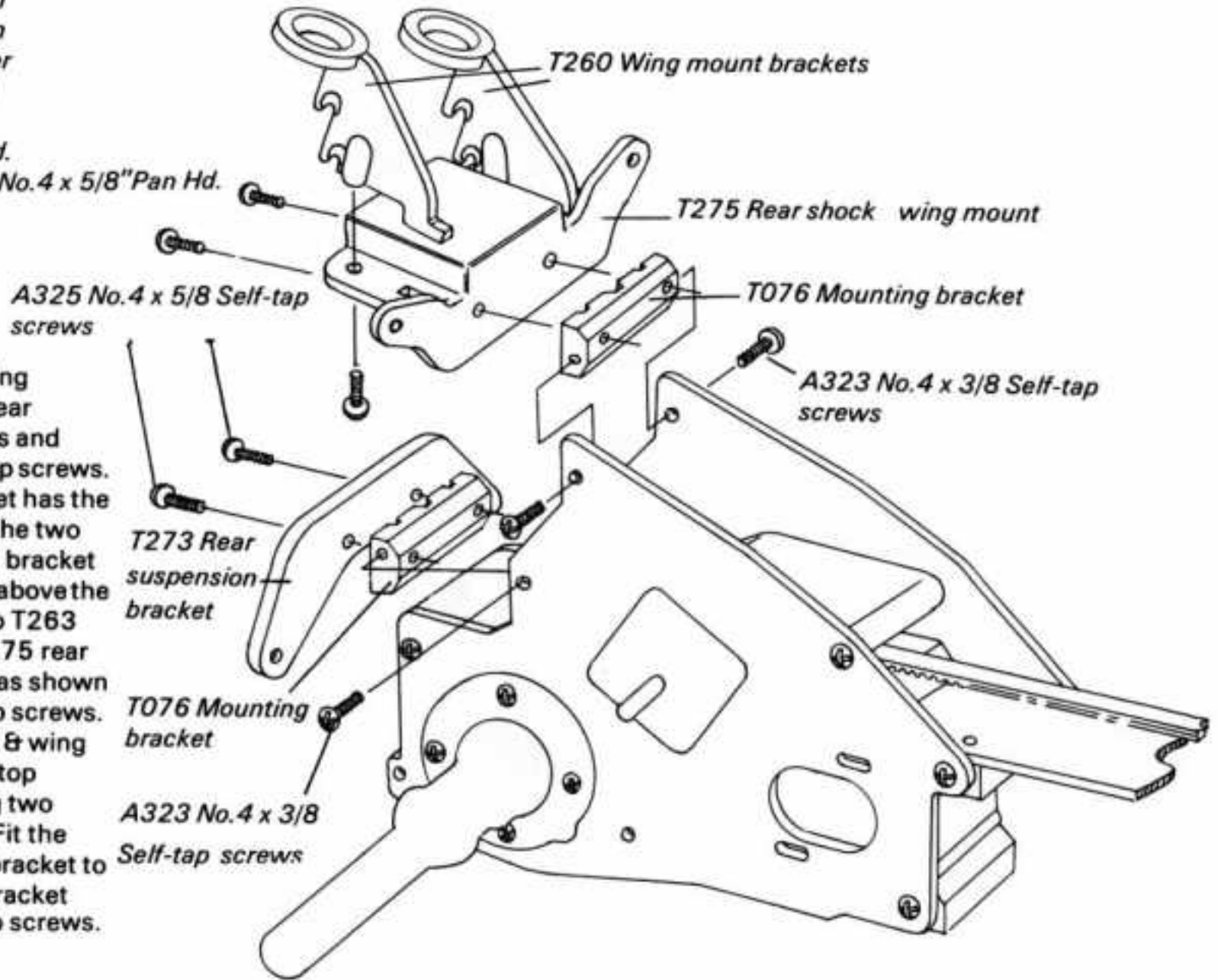

Lexan Moulding

Rear Suspension

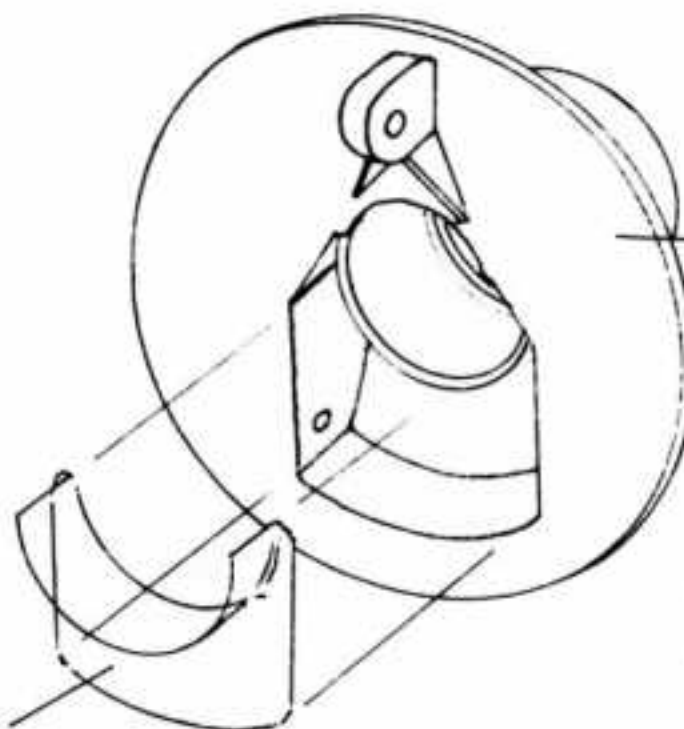

Lexan dirt shield

T199 Rear hub carrier

B/ Cut out the dirt shield piece from the lexan bodymoulding sheet. Trim the piece to obtain two rear hub carrier dirt shields shown. The lexan part should locate as the drawing shows and be a snug fit.

PARTS USED

- T076 Mounting Bracket
- A323 Screw Self Tap No.4 x 3/8" Pan Hd.
- T275 Rear Shock & Wing Mount
- T263 Wing Bracket
- T273 Rear Suspension Bracket
- T276 Rear Wishbone Pivot Brackets
- T238 Rose Joint - Socket
- T239 Rose Joint - Ball
- A327 Self Tap Screw No.4 x 1" Pan Hd.
- A414 Rear Wishbone Pivot
- A411 Pin 2.0 x 40mm
- T199 Rear Hub Carrier
- T268 Rear Wishbone
- A093 Turnbuckle M3 x 35
- A030 M3 x 10 Pan Hd.
- A325 Screw Self Tap No.4 x 5/8" Pan Hd.

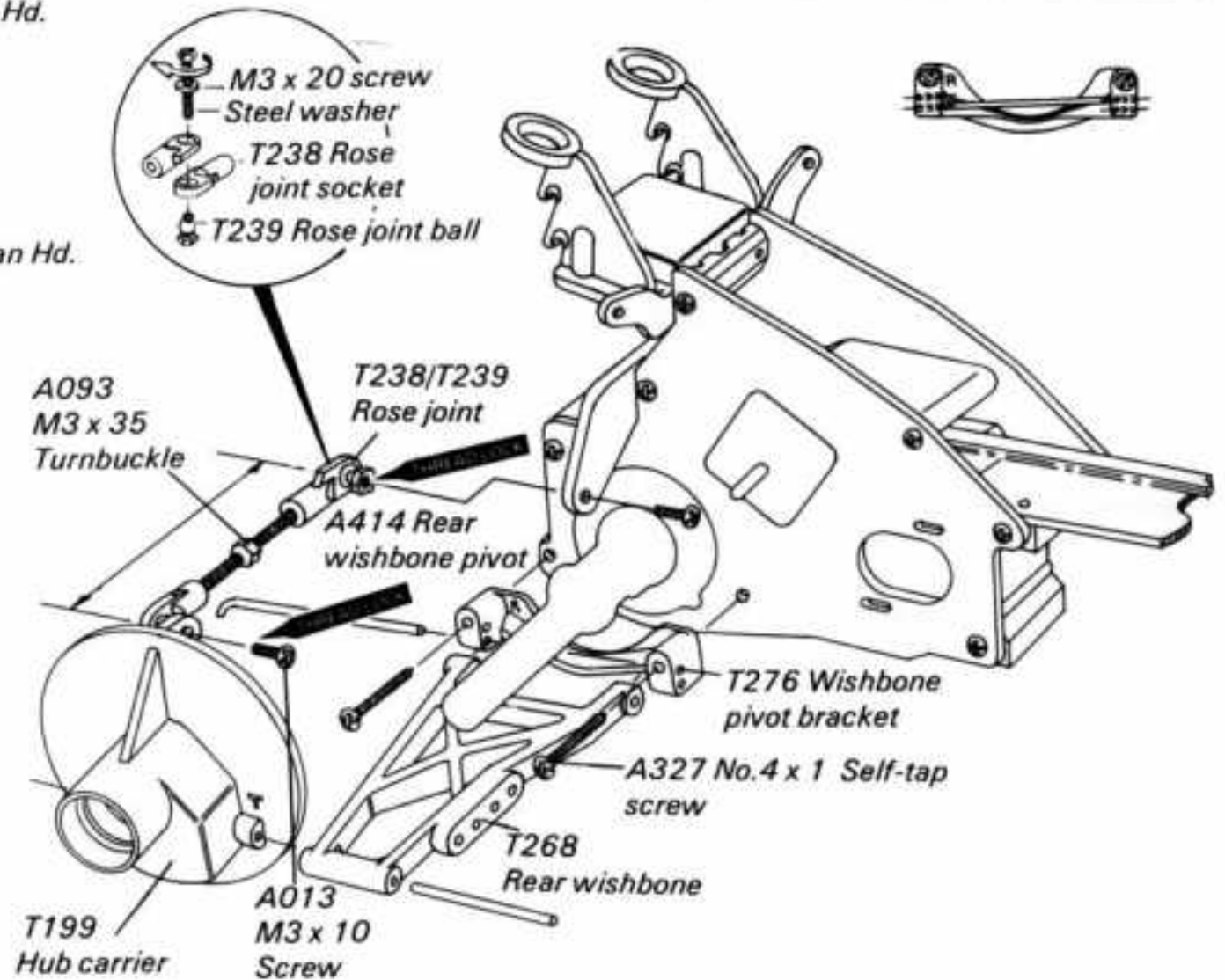

C) Assemble rear wishbones to hub carriers using A411 steel pins 2.0 x 40mm long. The pin will be tight in the boss on the hub carrier identified by 'T'. The wishbone must pivot freely. Fit both T276 wishbone pivot brackets to each side of the transmission plates using four A327 No.4 x 1 self tap screws. The wishbone pivot brackets are marked left and right. Assemble the wishbones to the T276 rear wishbone pivot brackets using A414 rear wishbone pivots. The rear wishbone pivot brackets are marked left and right. The steel pin should be fitted so that it goes through the lower hole at the rear and the upper hole at the front. This applies to both the righthand side and lefthand side of the car. The illustration shows

the righthand side. Assemble the T238/T239 rose joints as shown using a screw and washer. The upper socket is used as a spacer to aid assembly only. Make-up the rear suspension top links by screwing rose joints to each end of the M3 x 35mm turnbuckle.

This has a right and a lefthand thread to aid adjustment when fitted on the car. Equalize the thread engagement and make length approximately 47mm between centres of holes. Fit the top links to the rear suspension bracket using two M3 x 10 screws.

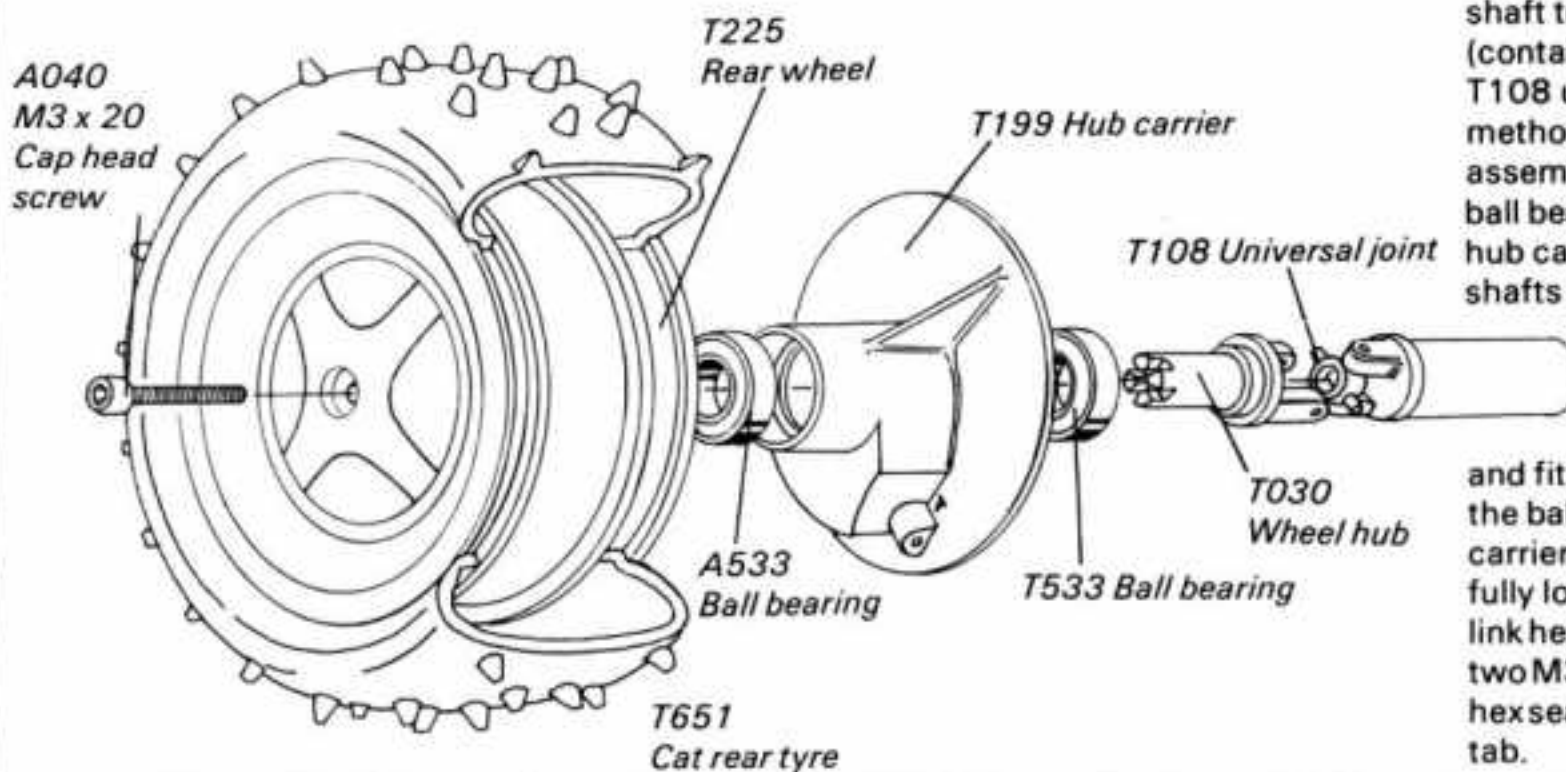

D) Assemble the T028 outer drive shaft to the T030 wheel hub (containing nyloc nut) with a T108 universal joint using the method shown in transmission assembly Step 4A. Fit two A533 ball bearings into each T199 rear hub carrier. Fit the outer drive shafts onto the inner drive shafts

and fit the T030 wheel hubs into the ball bearings in the rear hub carriers, making sure they are fully located. Finally fit the top link hexes to the hub carrier using two M3 x 10 pan head screws, the hex seated against the hub carrier tab.

PARTS USED

A180	'O' Ring
A323	Self Tap Screw No.4 x 3/8" Pan Hd.
A326	Self Tap Screw No.4 x 3/4" Pan Hd.
T058	Arm - Front Suspension
T109	Upper Front Wishbones
T110	Upper Front Wishbones
T111	Lower Front Wishbones
T112	Lower Front Wishbones
A410	Pivot Pin 2.0 x 26
A411	Pivot Pin 2.0 x 40
T156	Pivot Bracket Front - 15 Deg Rake
T160	Lower Wishbone Spacer
T161	Upper Wishbone Spacer

Step 1

A) Fit the T058 front suspension arm, facing rearwards and the T161 upper wishbone spacer to the T156 pivot bracket using two A326 self tapping screws. On the same side as the T058, fit the lower T160 wishbone spacer with two A323 self tapping screws; do not fully tighten at this stage. Make one lefthand and one righthand assembly. Fit the lower wishbone, marked 'B' to the lefthand side assembly using one A180 'O' ring either side of the T160 spacer and retain with the A411 pivot pin. Fully tighten the A323 screws in the T160 lower wishbone spacer. Repeat procedure for the righthand side assembly using the lower wishbone marked 'A'. Make sure the T109 upper wishbones pivots freely on the T058 arm before fitting the A410 pivot pin. The upper wishbone marked 'A' should be fitted to the righthand assembly and wishbone 'B' to the left.

B) Take two A411 steel pivot pins 2.0 x 40mm, measure 29mm from one end and carefully bend that section at 90 degrees as shown. Use these swivel pins to attach the front upright assemblies to the front transmission brackets. Fit tension bands over the lugs as shown with sufficient tension to prevent kick back from occurring during normal operation.

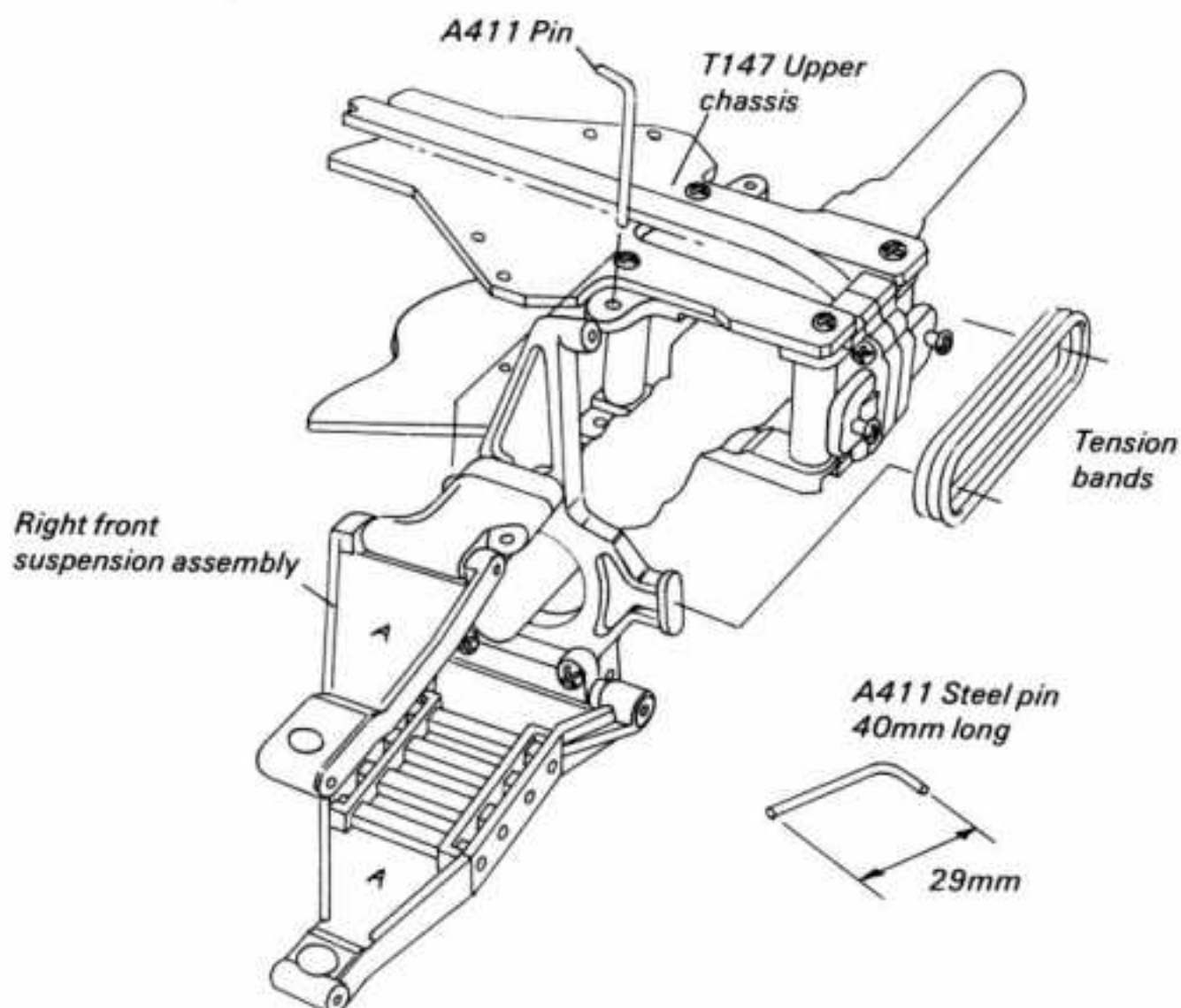
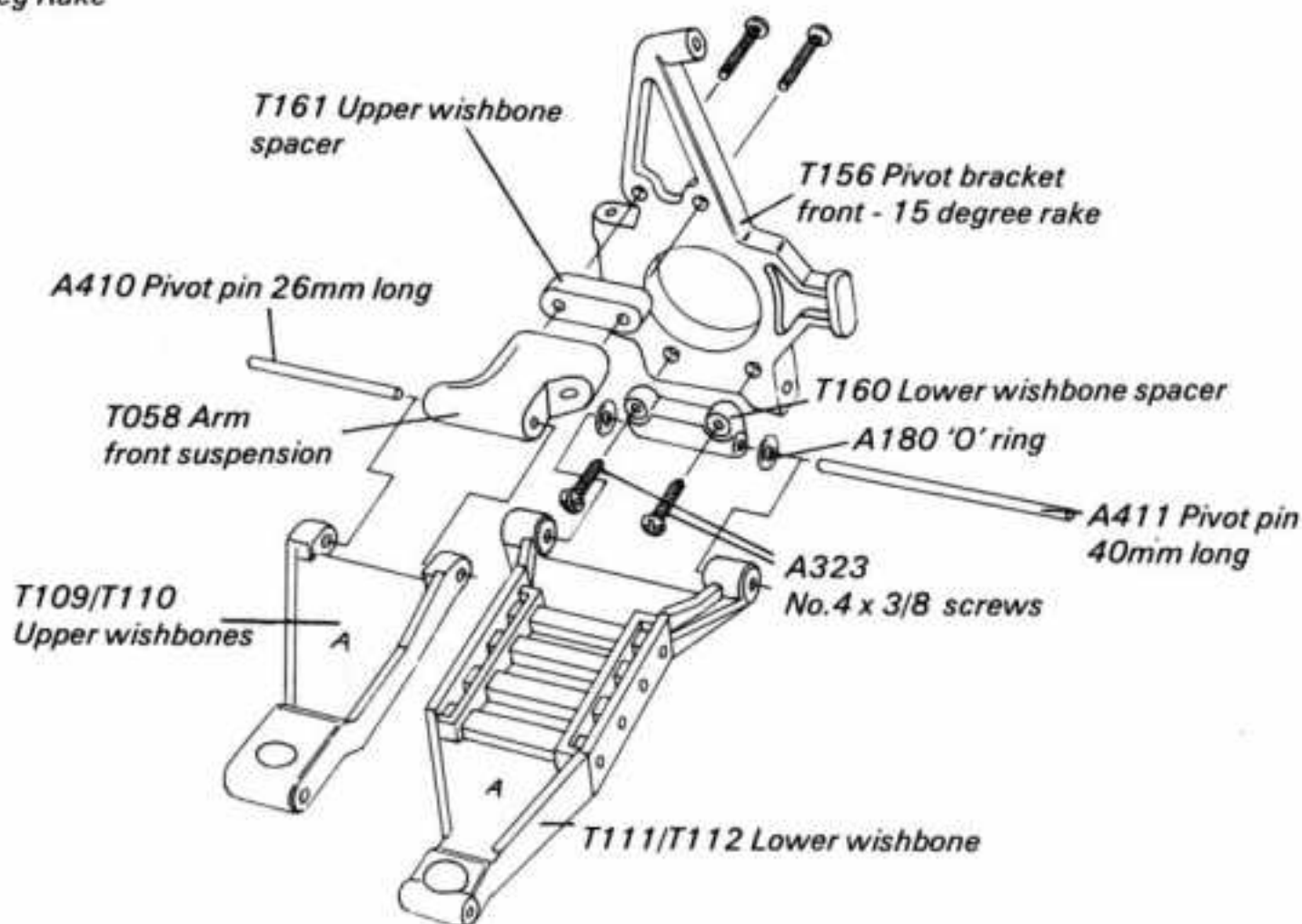

FRONT SUSPENSION

Bag No. T549

PARTS USED

- A009 Steel Screw M2 x 16 Ch Hd.
- A049 Steel Nuts M2
- A205 Steel Washer M2
- A301 Self Tap Screw No.2 x 3/16" Pan Hd.
- T045 Pivot Ball
- T098 Steering Lever
- T099 Radius Arm
- T139 Pivot Bush - Short
- T140 Pivot Bush - Long
- T170 Centre Trackrod
- A030 Steel Screw M3 x 10 Pan Hd.

Step 2 - STEERING

A) Fit the T098 steering lever to the T099 radius arm using an A301 self tapping screw. Assemble two T045 pivot balls to the T170 centre trackrod with A013 alloy screws; note the position of the cutaway in the T170 trackrod. Locate the two T139 short pivot bushes into the two T099 radius arms and secure with 2mm steel screws, washer and nuts, A009, A205 and A049. Push the two T140 long pivot bushes into the other end of the T099 radius arms and fit the whole assembly to the upper chassis using M2 steel screws, washer and nuts. Ensure that the steering arms move freely and add thread lock to all threads.

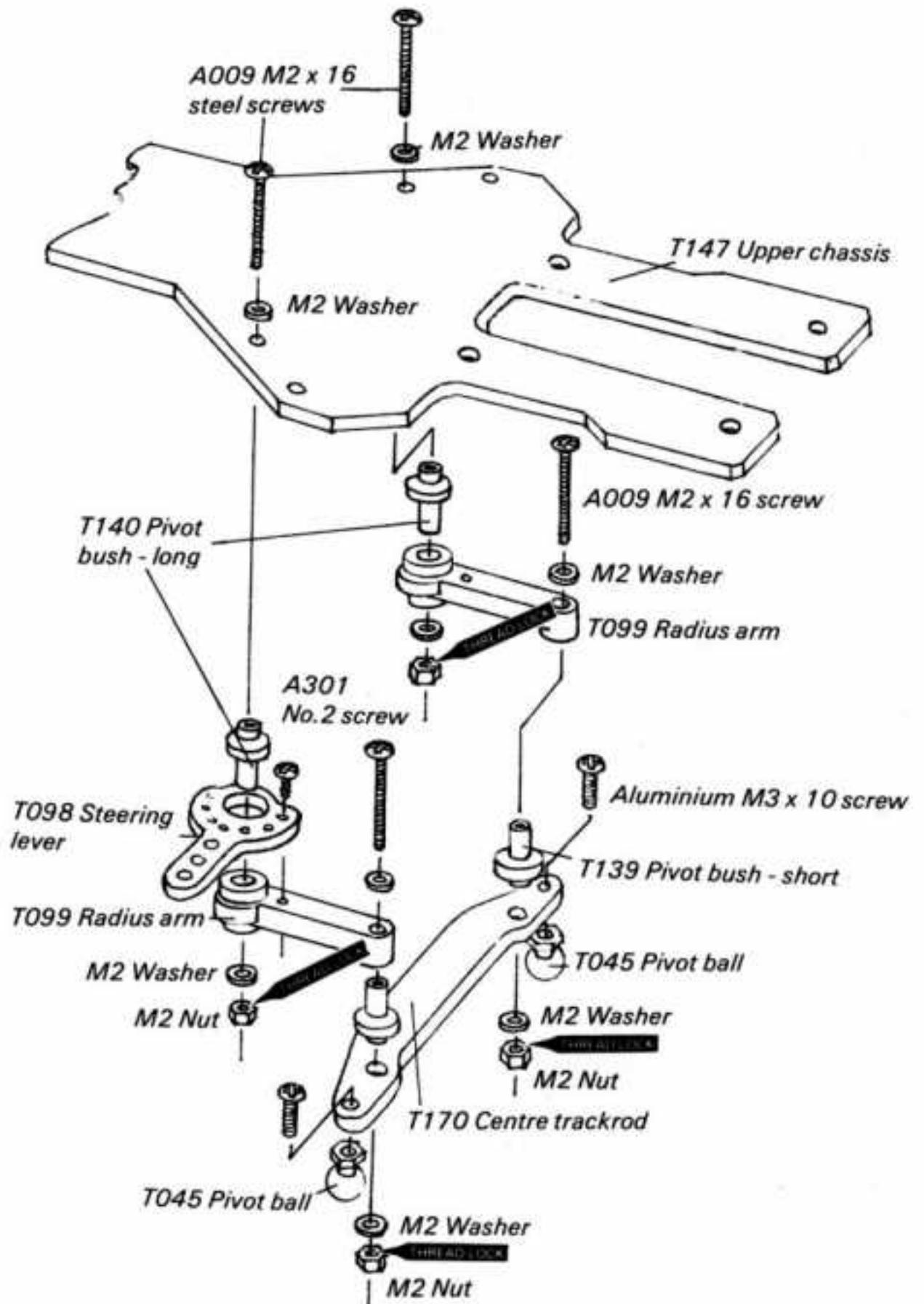

PARTS USED

- T052 Front Hub Carrier
- A533 Ball bearing
- A012 Aluminium Screw M3 x 8" Ch Hd.
- A206 Nylon Washer 3.3 x 8.0 x 1.6
- A305 Self Tap Screws No.2 x 1/2" Pan Hd.
- T030 Wheel Hub
- T028 Outer Drive Shaft
- T224 Front Wheel
- T653 Front Tyres 3 x 20 Hard
- T108 Universal Joint
- T100 Ball Socket
- A095 Turnbuckle M3 x 45
- A030 M3 x 10 Pan Hd. Screw

Step 3 - FRONT HUB CARRIERS & WHEELS

A) The illustration shows the assembly of the T045 pivot balls to the righthand front hub carrier. The A012 alloy screw used to retain the top pivot ball needs a small flat filing on the side of the head, this prevents the screw from rotating. A030 screws are used for the two other pivot balls. Note the use of an A206 nylon washer under the front steering pivot ball which helps prevent unwanted bump steer. Fit two A533 ball bearings into either side of the hub carrier with the black face outermost. Repeat for the lefthand hub carrier with the steering pivot ball in the opposite hole.

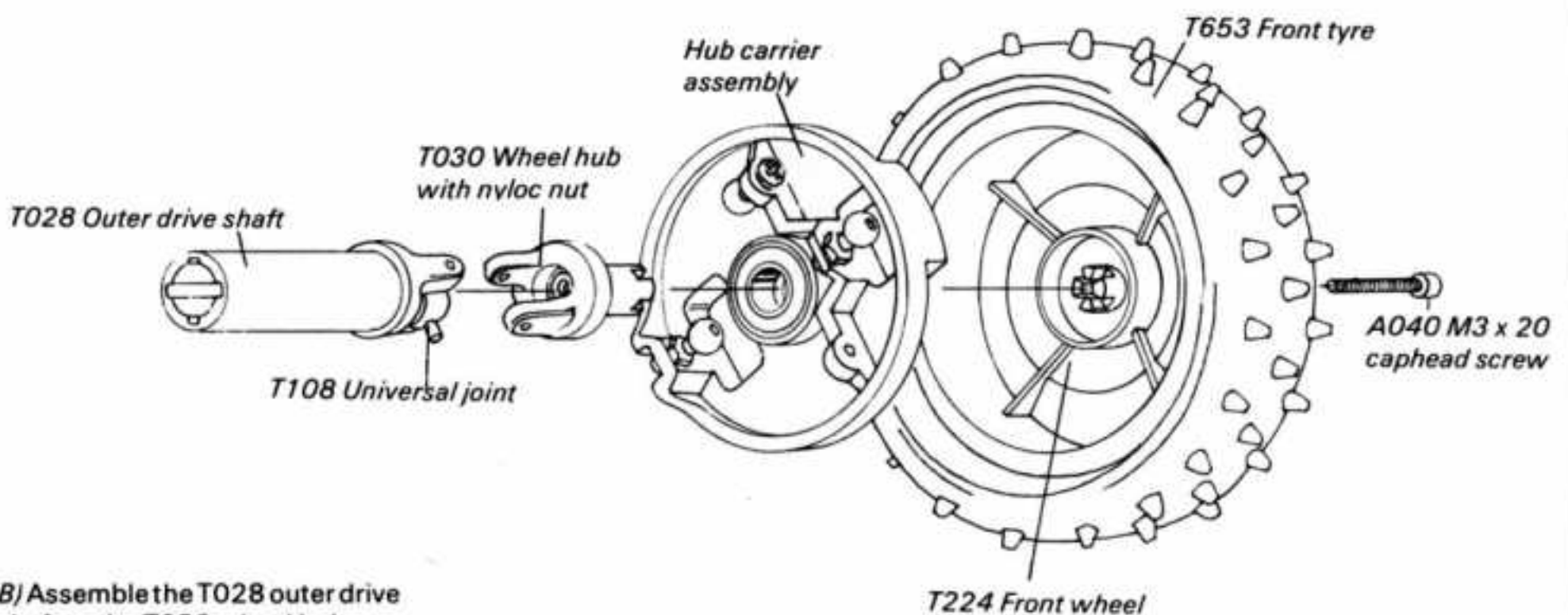
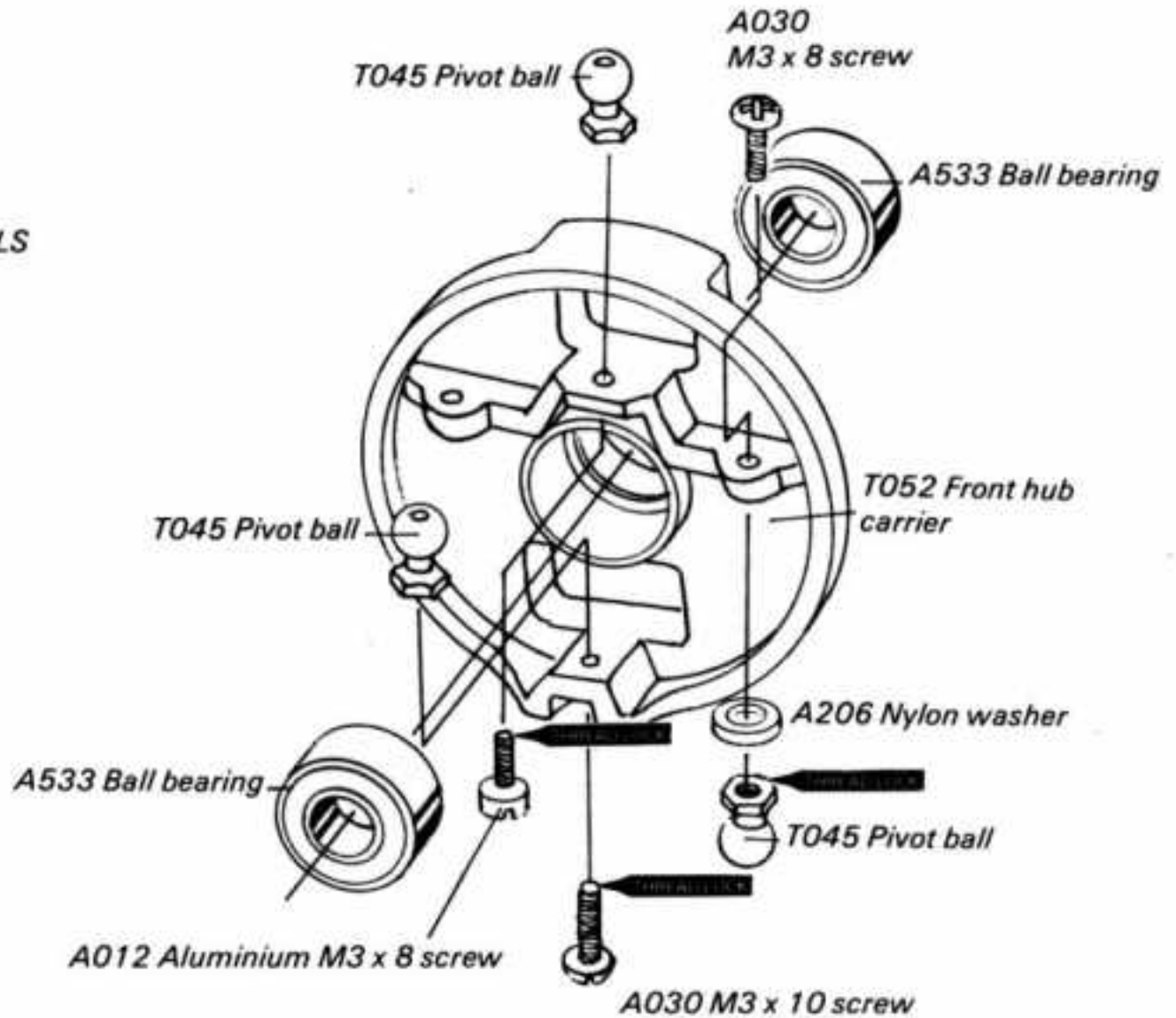

B) Assemble the T028 outer drive shaft to the T030 wheel hub (containing nyloc nut) with a T108 universal joint using the method shown in transmission assembly Step 4A. Fit the T030 wheel hub into the bearing in the hub carrier as shown. The

drawing shows the assembly of the lefthand side. Repeat for the other front hub carrier.

FRONT SUSPENSION

Bag No. T549

PARTS USED

- T052 Front Hub Carrier
- A533 Ball bearing
- A012 Aluminium Screw M3 x 8 Ch Hd.
- A206 Nylon Washer 3.3 x 8.0 x 1.6
- A305 Self Tap Screws No.2 x 1/2 Pan Hd.
- T030 Wheel Hub
- T028 Outer Drive Shaft
- T224 Front Wheel
- T653 Front Tyres 3 x 20 Hard
- T108 Universal Joint
- T100 Ball Socket
- A095 Turnbuckle M3 x 45
- A030 M3 x 10 Pan Hd. Screw

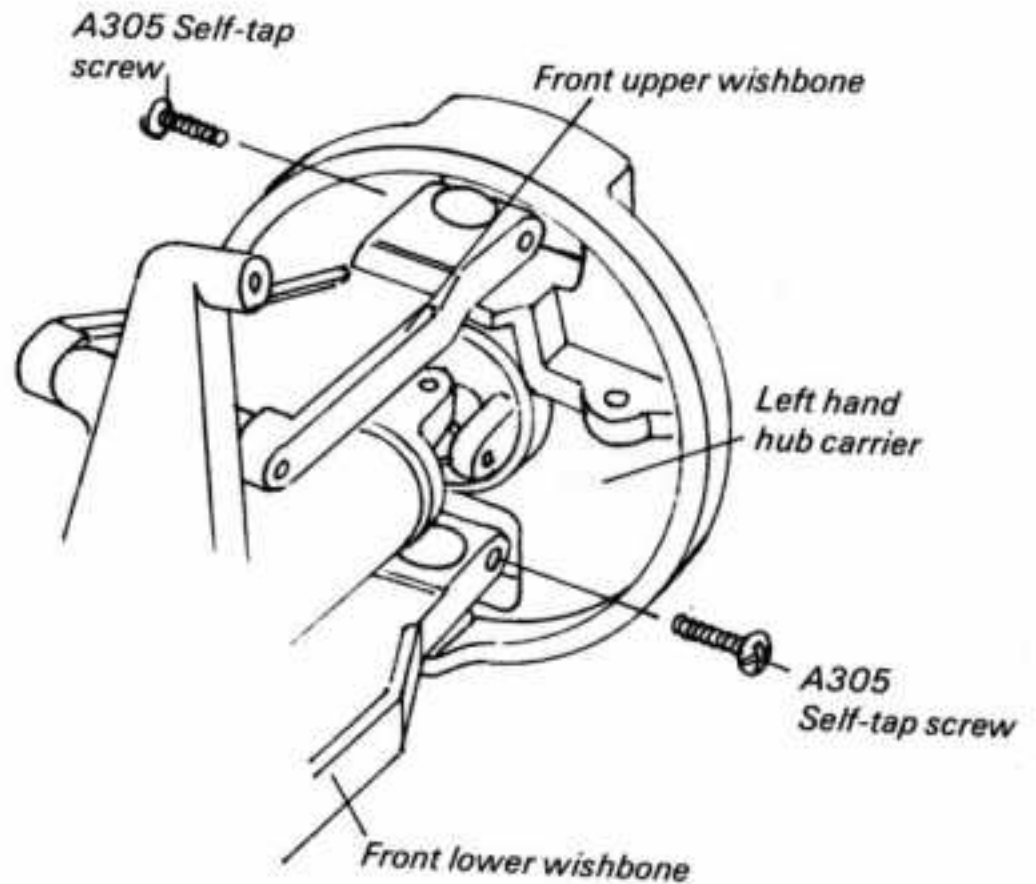

C) Fit the outer drive shafts onto the inner drive shafts and assemble the hub carrier assembly onto the front wishbones by spring fitting the wishbones over the pivot balls. Make sure that the correct hub is on the correct side, the downward facing pivot ball should be towards the rear of the car. Fit the A305 clamp screws in each wishbone and tighten only enough to take out excessive clearance. Note that the holes have clearance diameter on one side and a self tap diameter on the other.

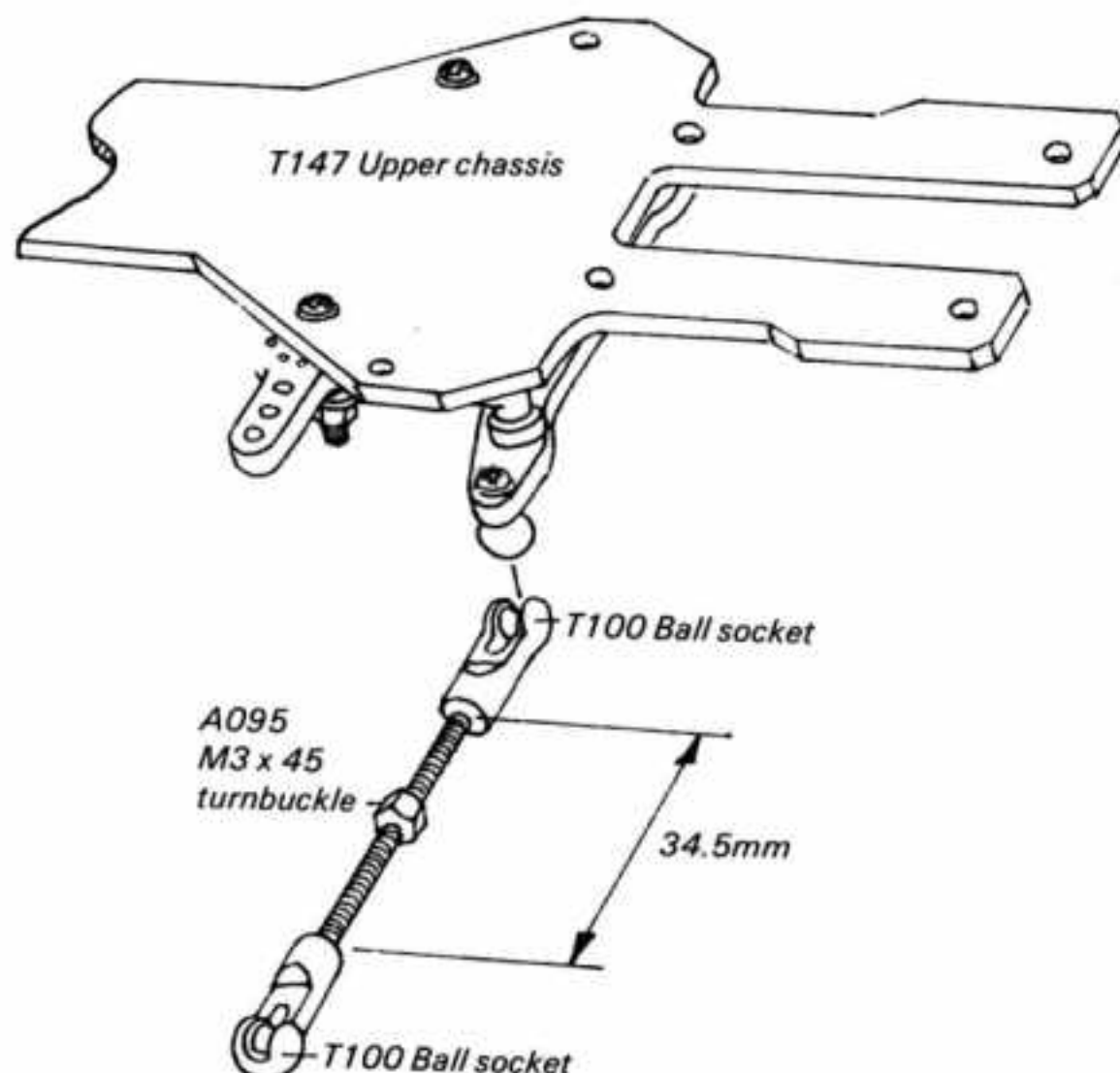

D) Assemble two T100 ball sockets to each end of both A095 turnbuckle M3 x 45. Each stud has a left and righthand thread to aid adjustment when fitted to the car. Equalize the thread between sockets until the length showing is approximately 34.5mm. Fit the steering trackrods to the car by spring fitting over the hub carrier pivot balls and centre track rod pivot balls.

PARTS USED

- T102 Rod End Ball
- T144 Front Anti-roll Bar
- T078 Wire Clamp
- A321 Self Tap Screw No.4 x 1/4" Pan Hd.
- T100 Ball Socket
- A092 Stud M3 x 24
- T045 Pivot Ball
- A090 Stud M3 x 12

Step 4 - FRONT ANTI-ROLL BAR

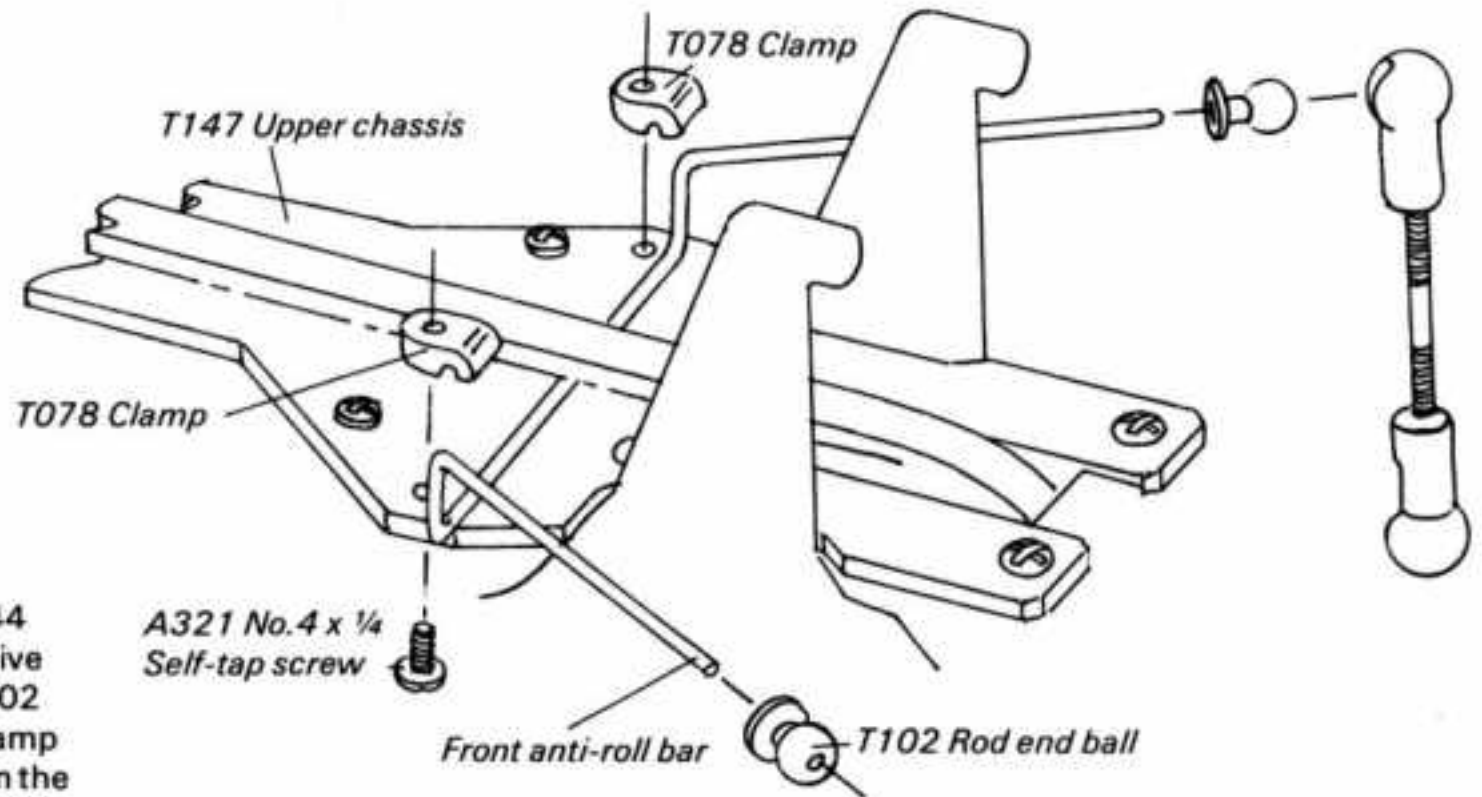

A) Clean the ends of the T144 front anti-roll bar with abrasive paper and solder the two T102 rod end ball to each end. Clamp the anti-roll bar in position on the top chassis plate with two A321 self tapping screws. The anti-roll bar fits under the belt and sits in front of the fixing screws. Make sure the roll bar can swivel freely in the clamps. Assemble two T100 ball sockets to each end of both A092 studs M3 x 24. The stud has a left and righthand thread. Equalize the thread between the sockets until the length showing is approximately 12mm. Spring fit the sockets over the rod end balls. Run the A090 stud right to the end of the thread in the T045 pivot ball and secure with loctite, then fit to the outside hole in the front of the lower front wishbone. Repeat for the opposite wishbone. Repeat for the opposite wishbone. Finally spring fit the anti-roll bar link to the wishbone pivot balls.

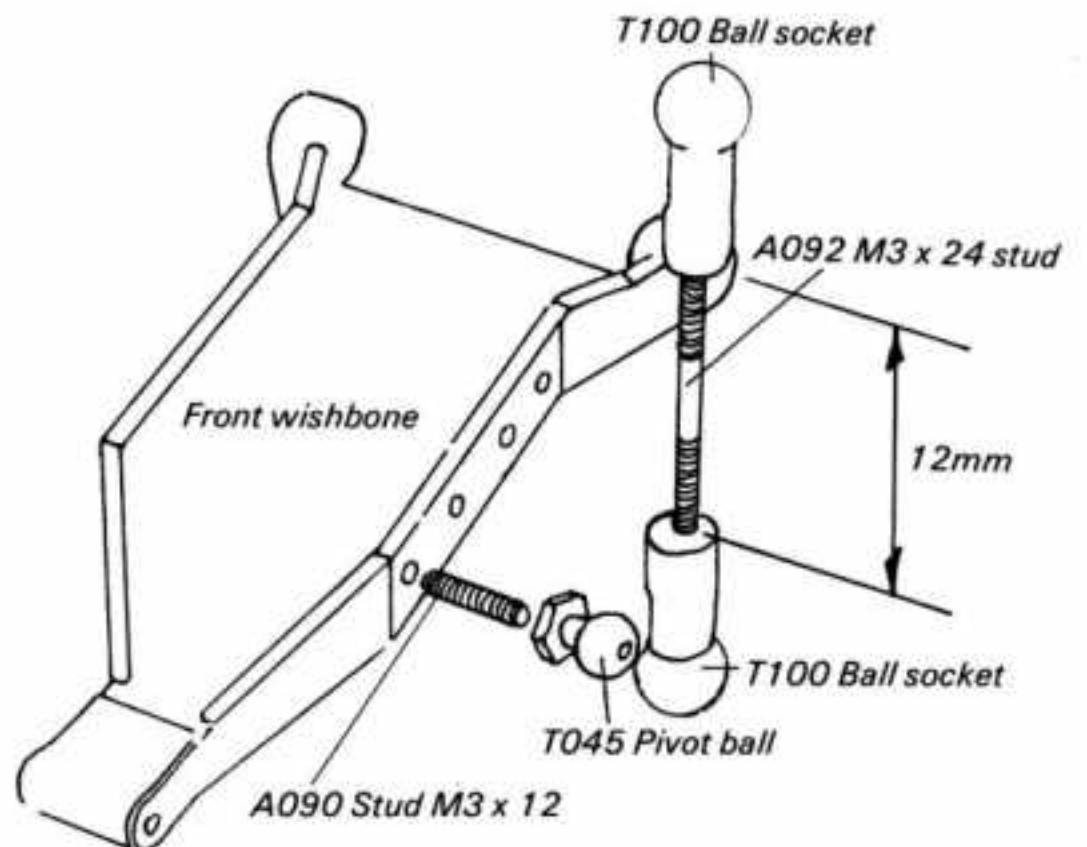

PARTS USED

- A181 Silicone 'O' Ring 1/8"
- A185 'O' Ring 5.0 x 1.6mm
- A209 Black Washer 3.3 x 7.8 x 0.8
- T059 Cap Shock Absorber
- T062 Piston Rod 16mm Stroke
- T063 Piston Rod 32mm Stroke
- T090 Spring Stop
- A230 Stepped Washer
- T092 Spring Spacer 1.0
- T096 Piston 1 sq.mm Hole
- T097 Piston 2 sq.mm Hole
- T117 Front Spring Stop Spacer
- T132 Suspension Spring 045 x 8 x 1.5 Front
- T133 Suspension Spring 045 x 11 x 2.5 Rear
- T158 Bush & Seal Housing
- A103 'E' Clip 1/8 x 0.12"
- A131 Circlip 8mm x 0.39
- T061 Body Long

Step 1

- A206 Nylon Washer 1.6
- A039 M3 x 16" Cap Hd.
- A048 M3 Nut
- A051 Nyloc Nut
- T093 Spring Spacer 2.0
- T094 Spring Spacer 4.0
- T095 Spring Spacer 8.0
- A038 M3 x 12" Cap Hd.
- T238 Rose Joint Socket
- T239 Rose Joint Ball

SHOCK ABSORBERS

Bag No. T555

REAR SHOCK

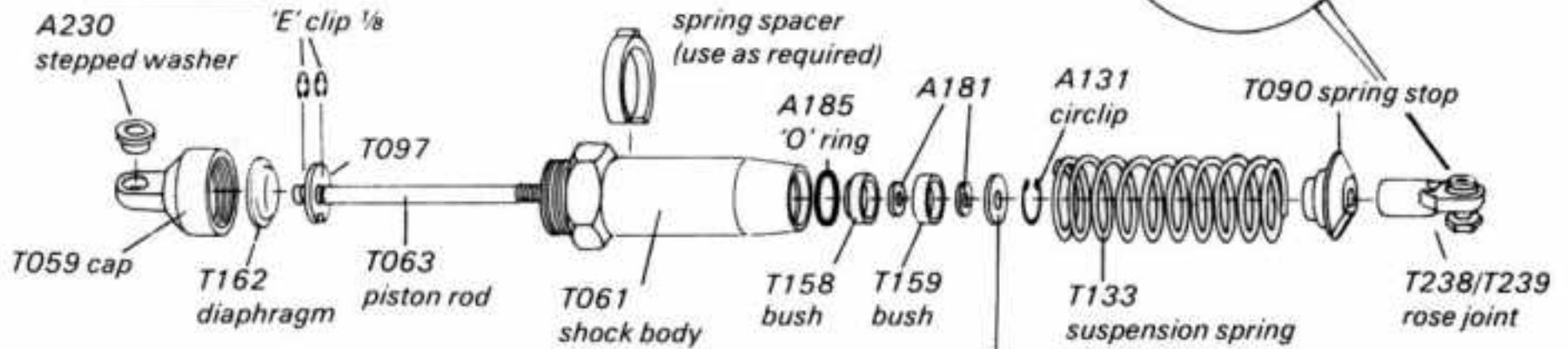

FRONT SHOCK

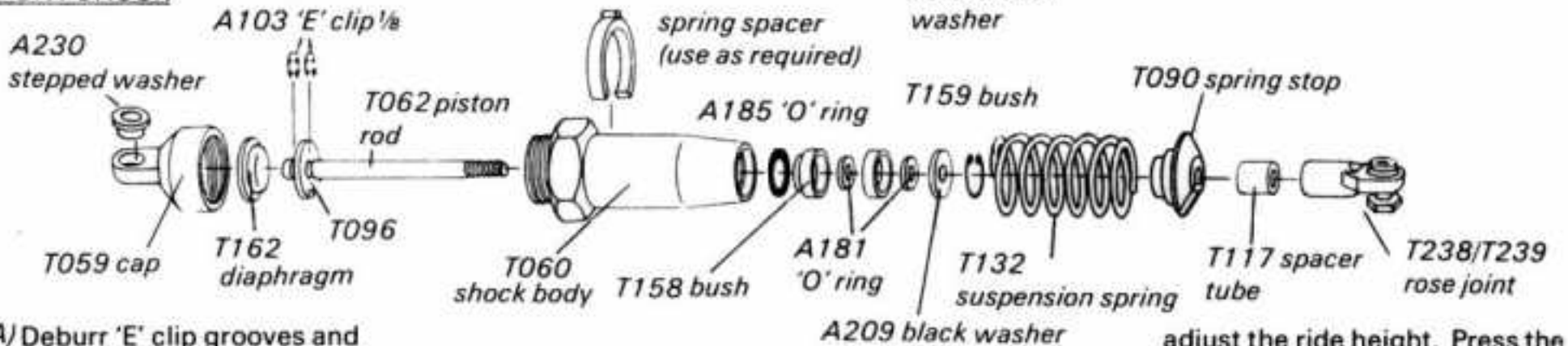

A) Deburr 'E' clip grooves and threads on piston rods T062/T063 before assembly to avoid damage to the seals. Fit a small 'E' clip A103 to the lower groove in the front T062 piston rod, followed by a T096 piston (small notch) retained with a second 'E' clip. Repeat the procedure with the T063 rear piston rod and T097 piston (large notch). Make sure all the 'E' clips are secure in their grooves; Check assembled piston in shock absorber body for clearance over the whole length of stroke. Diagrams show the order of assembly for the shock absorber seals and bushes; the sequence being:- A185 'O' ring, T158 bush and seal housing, A181 'O' ring, A209 black washer and finally, the A131 circlip to retain the assembly. The above sequence is the same for all four shock absorbers.

B) Lightly oil the four piston rods. Carefully push rods down through their respective shock absorber bodies to avoid damage

to the seals. Screw two T238 rose joint assemblies to the bottom of the rear shock absorber piston rods, do not damage the piston rod. Cut two 6mm lengths from the black T117 spacer tube and slide one of these onto each front piston rod before fitting the two T238 rose joint assemblies. Failure to do so this will cause the spring stop to foul the centre trackrod. With the piston rods extended, fill the shock absorbers with a light oil. Work the pistons up and down to release any trapped air. Fit the T162 shock absorber diaphragm into the oil filled shock absorber body so that all air is expelled. Fit T059 cap and check for smooth action. Fit the front suspension springs T132 to the front shock absorbers and retain with a T090 spring stop. Repeat the procedure for the rear shock absorbers using the T133 rear suspension springs.

C) Insert spring spacers T092/T093/T094/T095 as required to

adjust the ride height. Press the A230 stepped washer into the T059 cap of each rear shock absorber.

Step 2 - MOUNTING SHOCK ABSORBERS

Fit two M3 x 16 cap head screws to the T275 shock mount and lock into place using M3 nuts. The thread should point towards the front of the car. Fit rear shock absorbers and retain with an A208 nylon washer and an A051 nyloc nut. Do not fully tighten nut, shock absorber must have some clearance over the full range of suspension travel. At the bottom screw M3 x 12 cap head screws through the rose joint ball and into the second hole out in the lower wishbones; hexagon head towards the wishbone. Mount the front shock absorbers by using two A039 cap head screws and two A208 nylon washers in the two front uprights. At the bottom use an M3x16 caphead screw and an A206 nylon washer and screw into the second hole out in the front lower wishbones.

BODYSHELL, UNDERTRAY & WING

PARTS USED

- T261 Upper Wing Washer
- T262 Lower Wing Washer
- A407 Pin 1.5 Dia x 11.8mm
- A190 'O' Ring 9.0 x 1.6mm
- T575 Bodyshell Moulding
- T576 Undertray Moulding
- T281 Front Bumper

Step 1

A) Cut away shaded areas of body undertray mouldings as shown. First wash both mouldings to remove any oil or dirt and rinse thoroughly. Paint the inside of the body and undertray using lexan paint. A colour scheme can be obtained by masking a portion with tape, painting one colour, then removing the tape and painting another colour. Apply the lightest colour last. When painting the undertray mask to leave the centre section clear, where belt runs and on either side where the fixing holes will be positioned. To fit undertray place the car upside down on a flat surface and remove all lower chassis screws. Place undertray in position on chassis and pierce holes through clear section using a round pointed tool. Replace all screws and add front bumper, which is attached using the four countersunk self tap screws at the front of the car. Trim the top belt cover in position and pierce holes through belt cover and with the car supported on a flat base, remove all the top chassis screws except the rearmost ones. Fit the top belt cover in position and pierce holes through as with the undertray. Replace all screws. Two notches will have to be cut to clear the front anti-roll bar. The bodyshell is retained by velcro patches in the positions shown. Decals can be applied to finish the bodyshell.

B) Cut out wing and side plates from lexan moulding and mask and paint as described for the bodyshell. Drill two holes 7mm dia in the positions shown. Insert T261 upper wing washer from the top and fit T262 lower wing washer from below. Insert two A190 'O' rings and A407 pin so that the 'O' rings are retained by the pin as shown in the cross section diagram. Repeat for the other hole. Fit wing to car by pushing 'O' rings through hole in T263 wing bracket and hooking over either of the lugs.

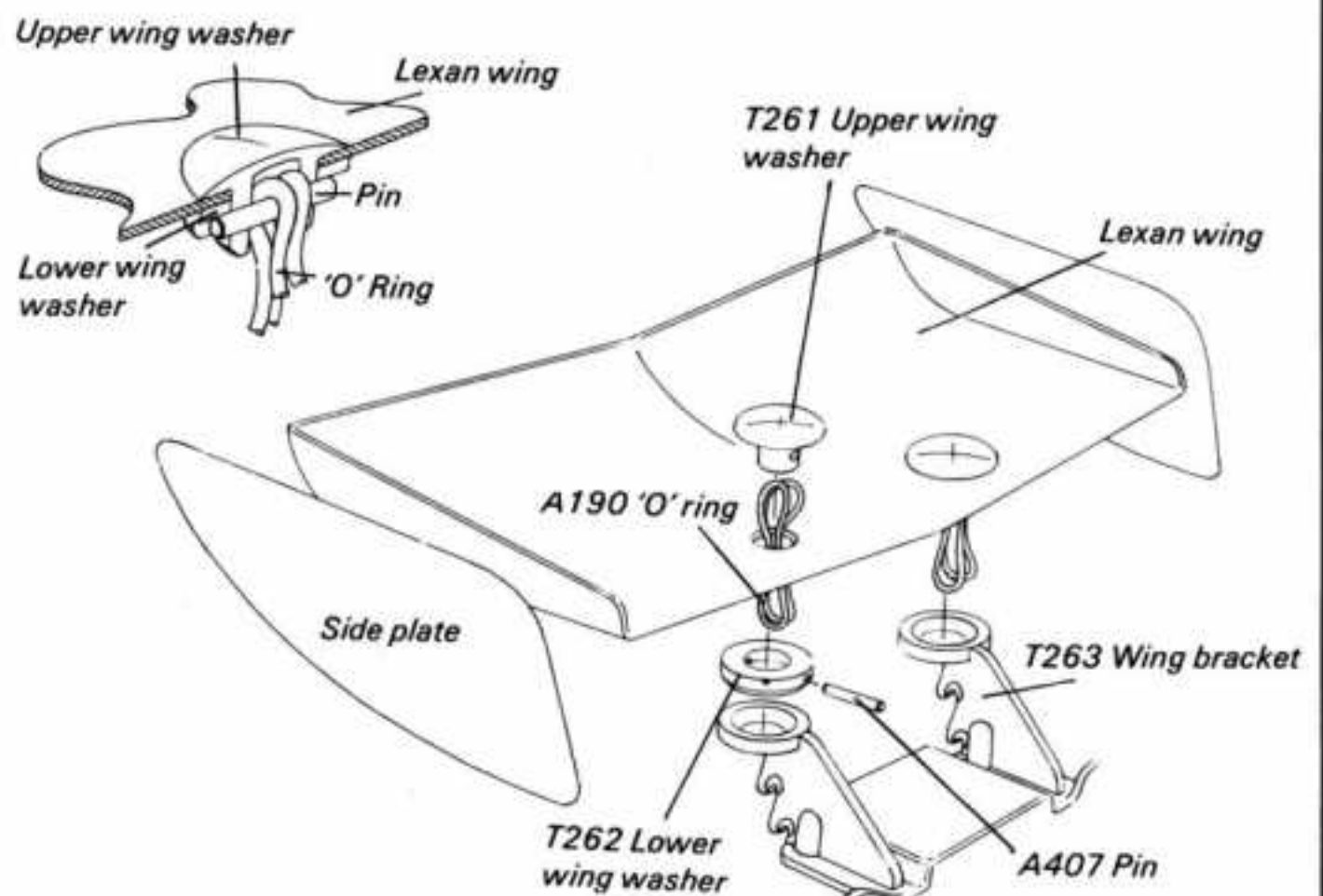
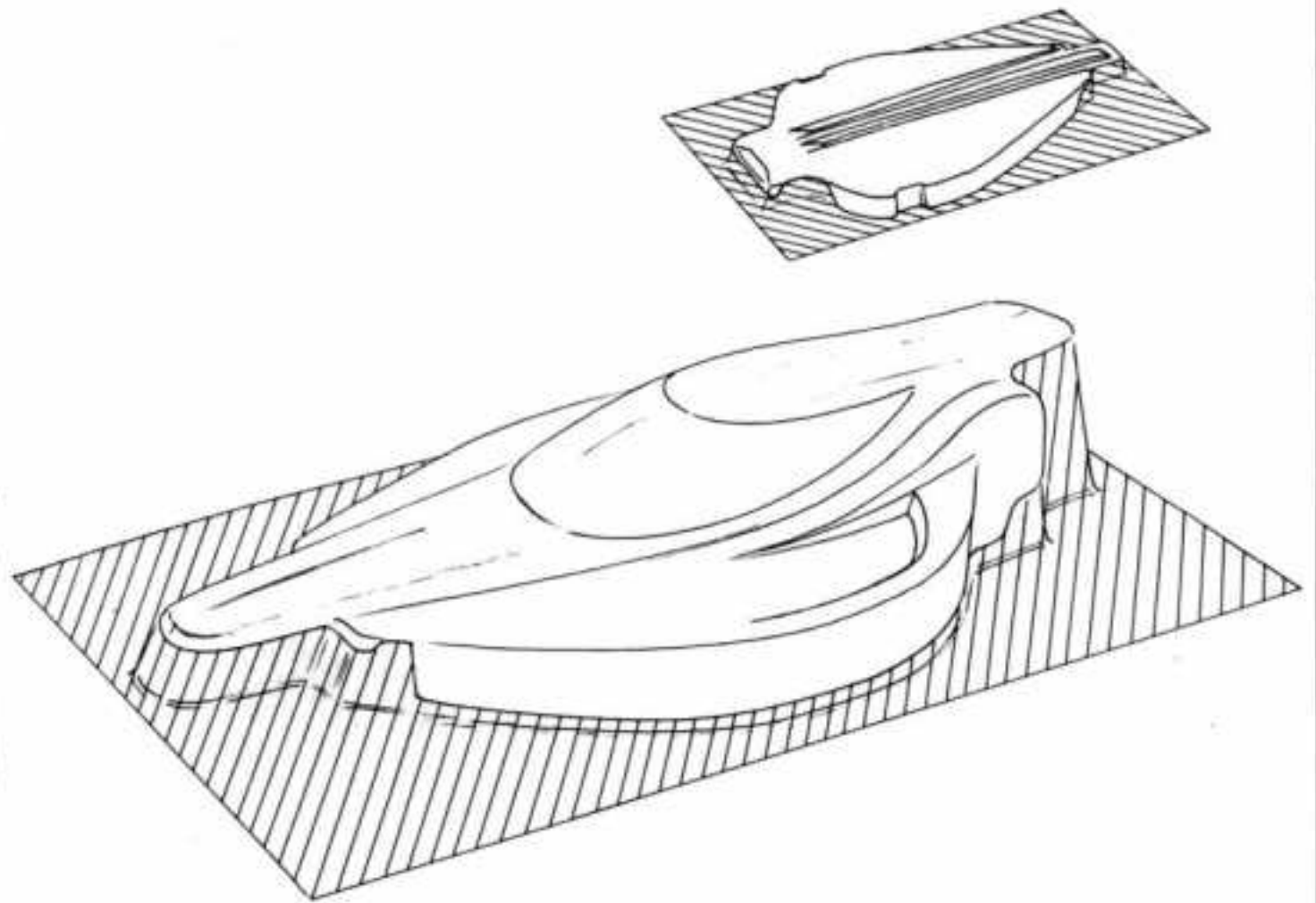

LONG BELT ADJUSTMENT

WHEELS & TYRES

The long drive belt can now be adjusted to the correct tension. Slacken the eight front transmission housing fixing screws and slide the front differential forwards. Use only enough tension to stop the belt jumping the pulley teeth. Overtensioning of belt will result in loss of performance and the belt may be pulled off the side of the pulley by the excess tension.

Use the two screws in T292 tension bar to make final adjustments and align the front transmission housing to allow the belt to run in the centre of the pulley. Finally retighten all the eight front transmission housing screws.

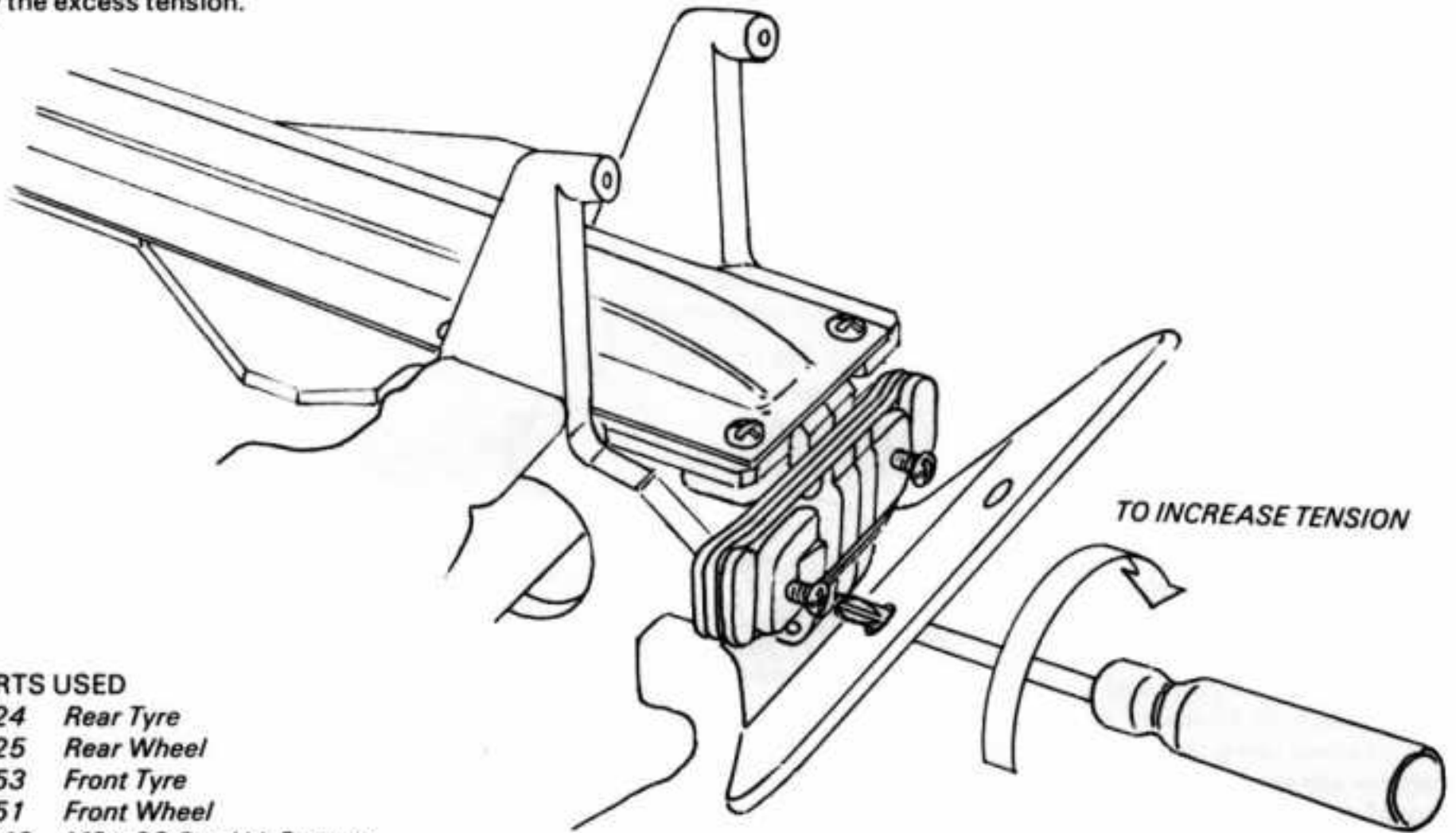

PARTS USED

- T224 Rear Tyre
- T225 Rear Wheel
- T653 Front Tyre
- T651 Front Wheel
- A040 M3 x 20 Cap Hd. Screws

A) Fit the tyres to the wheels taking care to ensure that the tyre bead properly seats in the grooves of the wheels. Make sure wheels do not have 'Flash' at the joint line which could prevent the

tyre bead from sitting properly in position. Fit the wheels to their respective hubs using A040 M3 x 20 cap head screws. Hold the drive shaft and fit the wheel to the hub with the screw acting as a

pilot. Make sure the hub and wheel are fully engaged. Do not over tighten the screw.

Front Wheel & Tyre

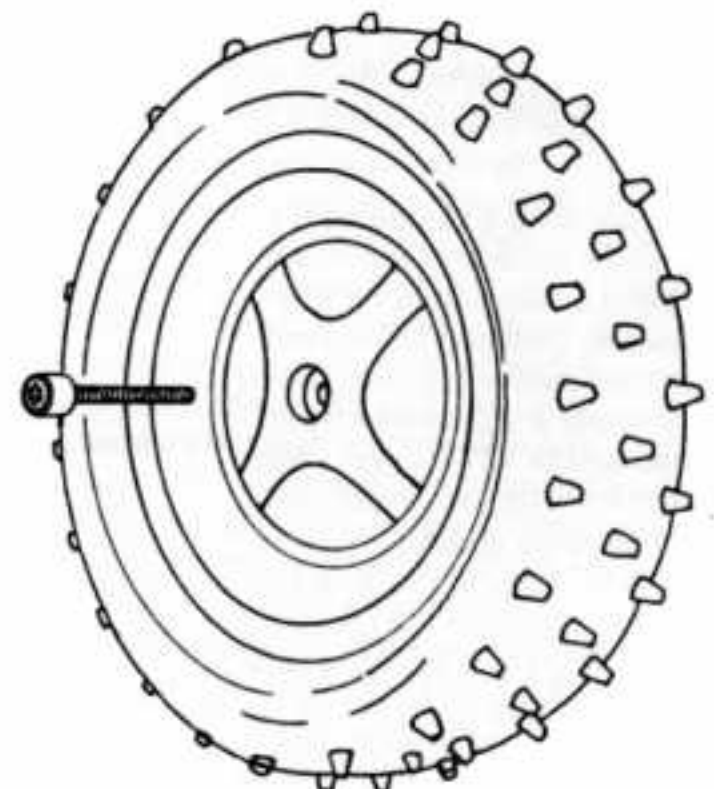
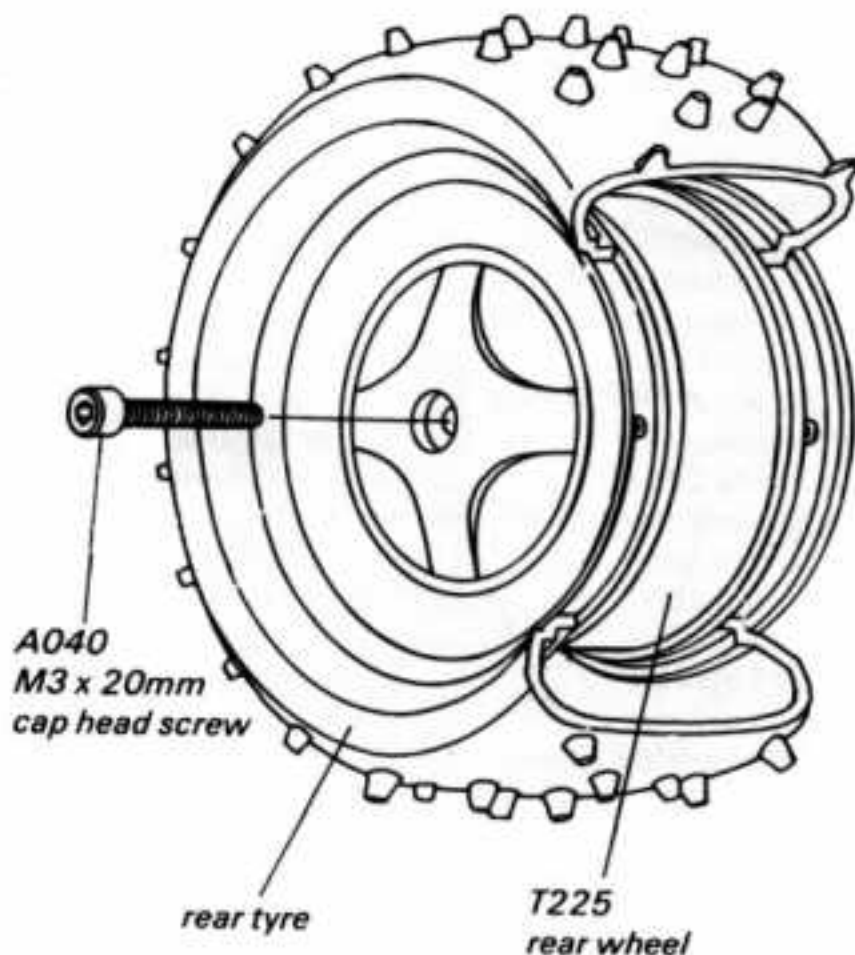

PARTS USED

A180	'O' Ring
T229	95T Gear 48DP
T234	22T Pinion 48 DP
A225	M3 Steel Washers
A405	Pin 2.0 x 7.8mm
A035	M3 x 6" Cap Hd. Screws

FITTING ELECTRICAL EQUIPMENT**Step 1 - FITTING MOTOR & GEAR**

FITTING AERIAL

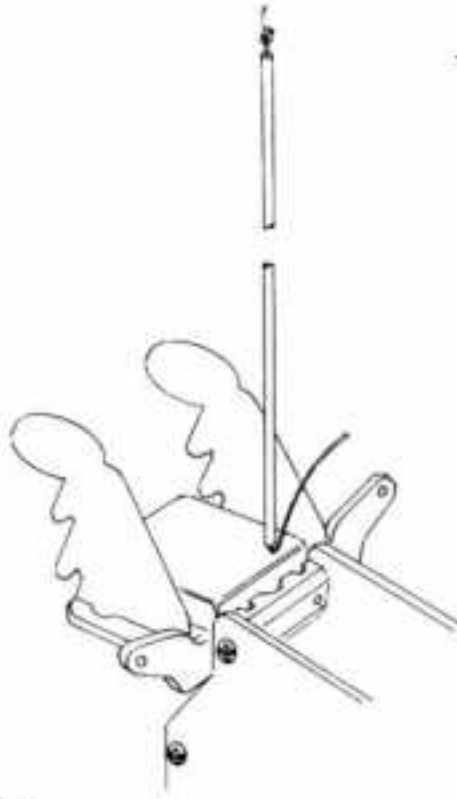

A) Assemble 95T Gear to the transmission by first fitting A405 steel pin into the layshaft and sliding the 95T gear onto the shaft making sure the pin engages in the slot. Retain with A180 'O' ring. Fit the motor using two M3 x 6 cap head screws and washers. Fit the 22T pinion ensuring the grub screw clamps against the flat on the motor spindle. Make sure the pinion and gear are in line. Adjust the motor position so that gears fully mesh but do not bind, check by rotating gears several times.

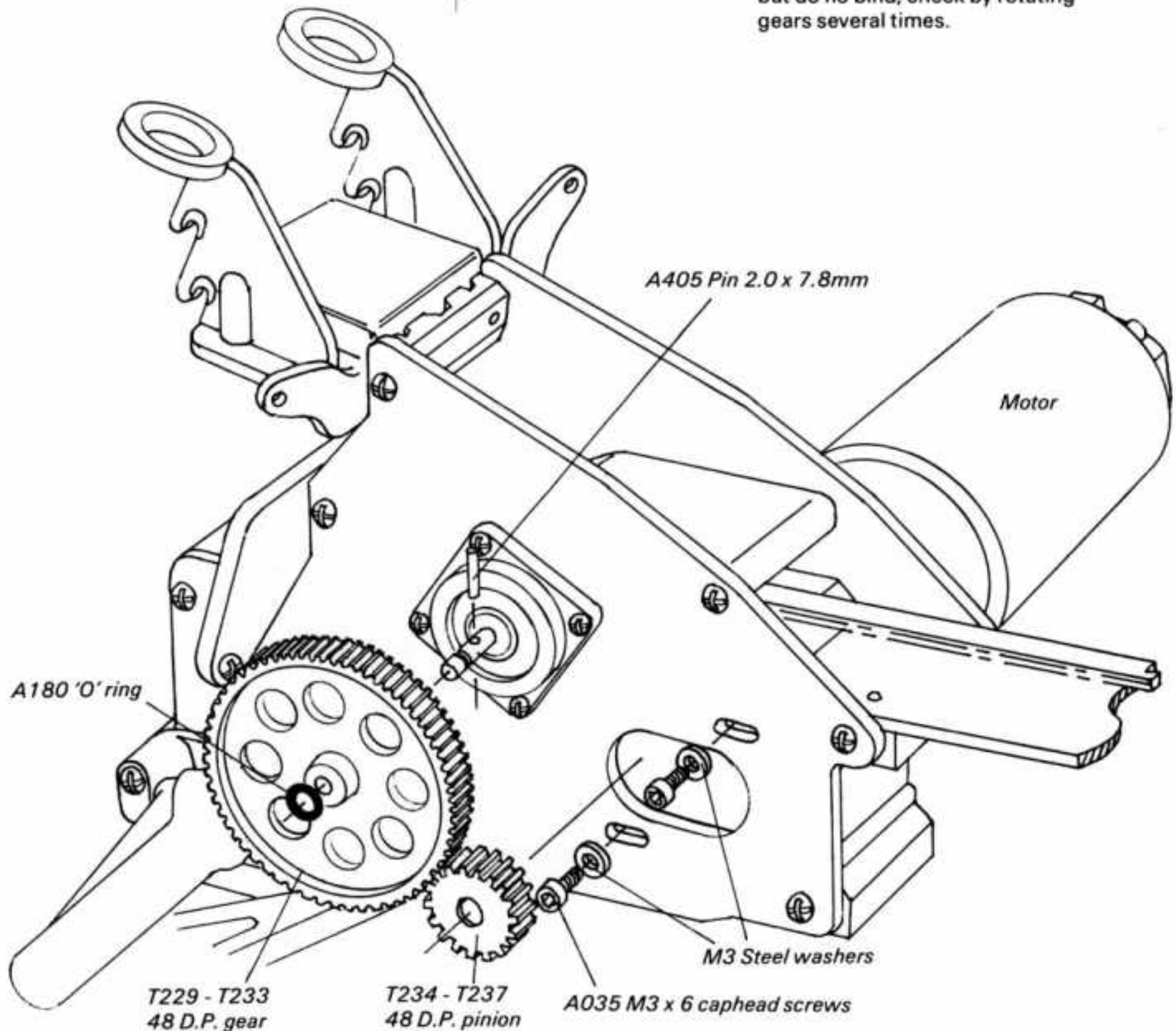

PARTS USED

- T114 Servo Saver Moulding
- T115 Servo Saver Spring

FITTING ELECTRICAL EQUIPMENT

Step 2 - SERVO SAVER

A/Select the servo saver fitting to suit your servo and fit the T115 servo saver spring over the T114 moulding as shown; twist the spring downwards into its correct position. The coils of the servo saver must tighten as the saver operates.

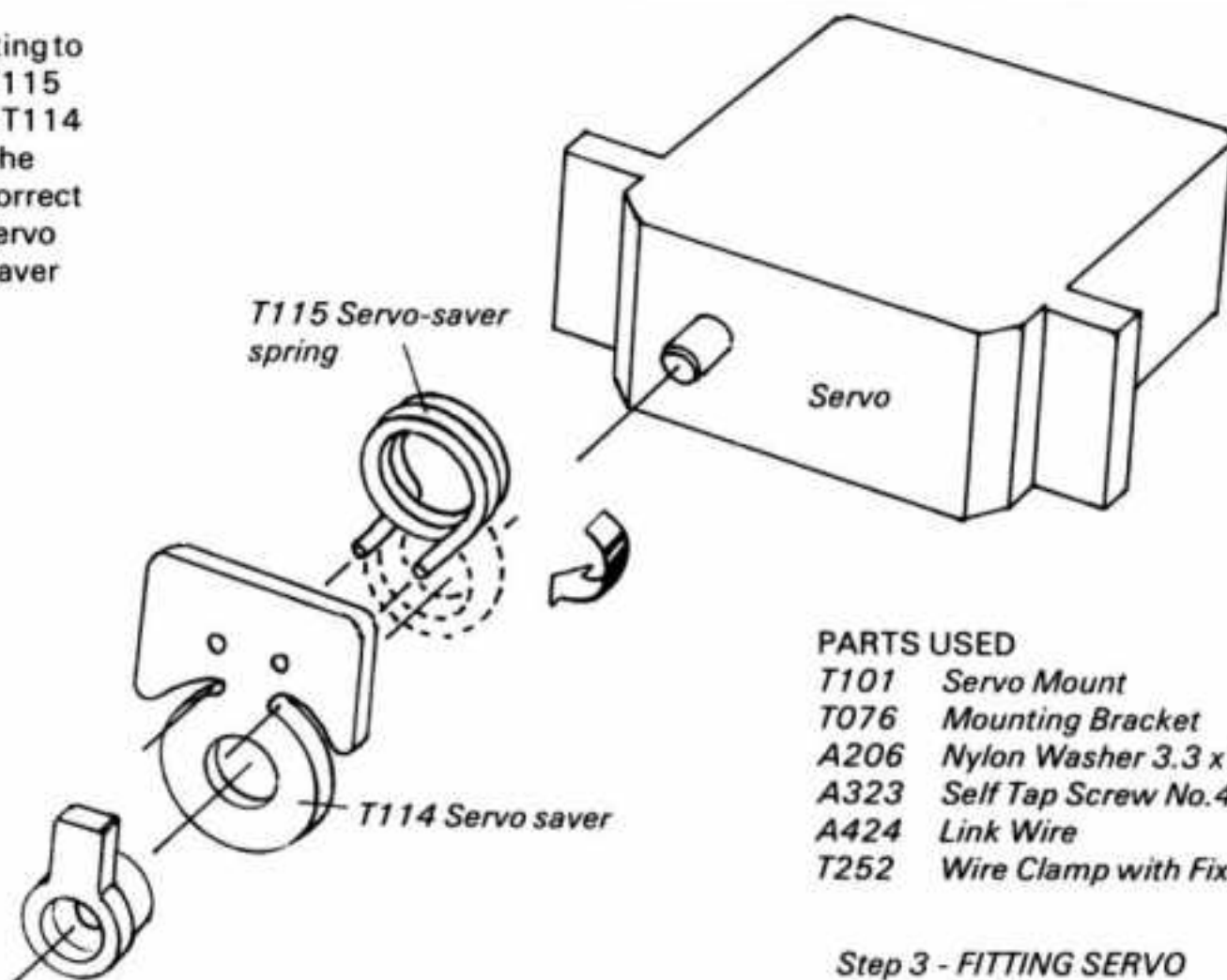

PARTS USED

- T101 Servo Mount
- T076 Mounting Bracket
- A206 Nylon Washer 3.3 x 8.0 x 1.6
- A323 Self Tap Screw No.4 x 3/8" Pan Hd.
- A424 Link Wire
- T252 Wire Clamp with Fixing Screw

Step 3 - FITTING SERVO

Fit the two rear servo mount posts to the chassis plates using four A323 self tap screws. The front servo mounting has two A206 nylon washers between it and the lower chassis plate, secure with two A323 self tap screws. Using the two link wires and clamp, the servo can be connected to the steering arm as shown. The link wires may need to be shortened.

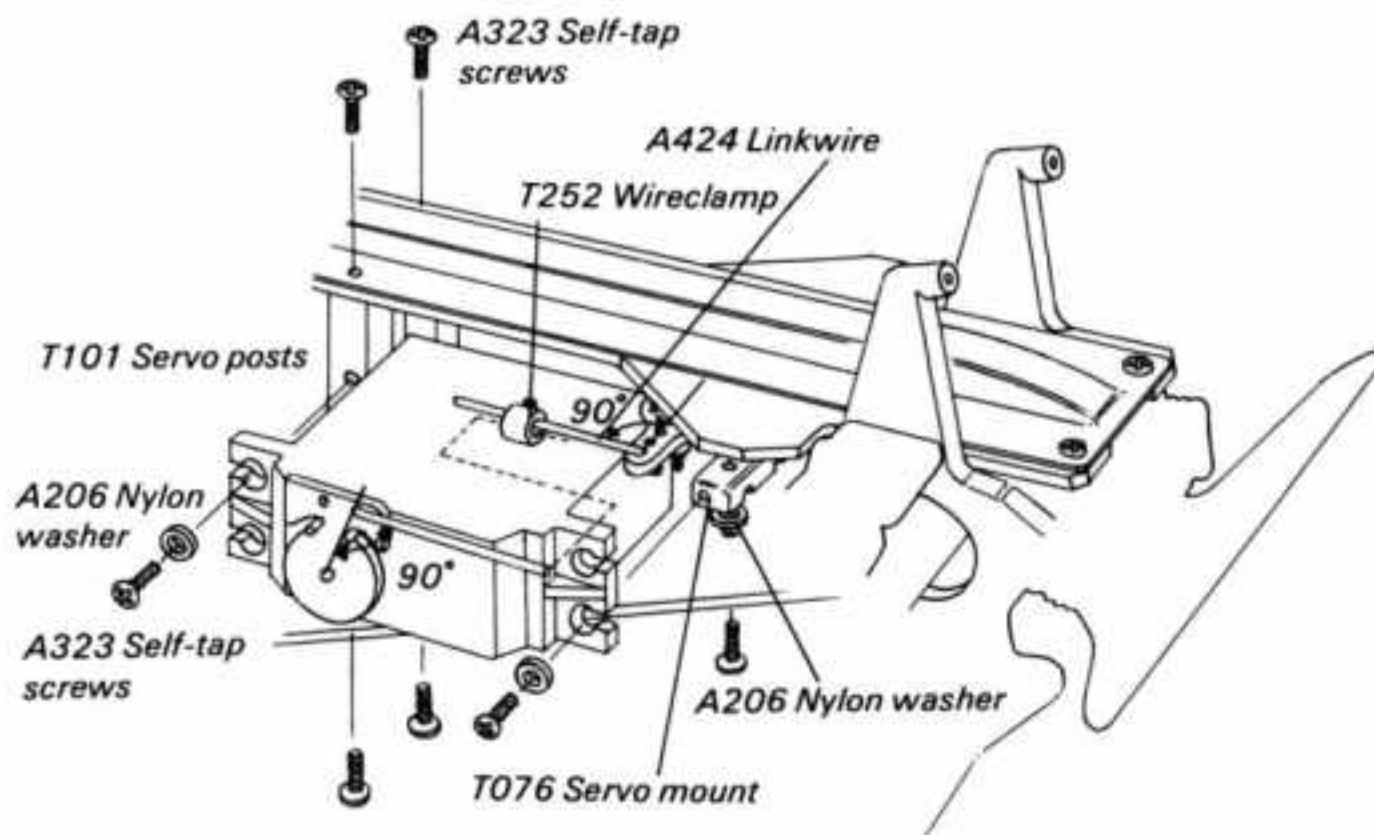

- 1) Make sure all screws are tight. Recheck after every race.
- 2) Differential adjustment

The differential should not slip under normal use. The correct tension is sufficient to give enough drive for the prevailing track conditions without slip and without excessive tension.

When you first run the car punch the throttle momentarily to find if there is slip, this sounds just like belt slip. If you have correctly adjusted the belt tension (Transmission Assembly step 9) then tighten differential until slip is eliminated. Tighten the differential by inserting a screwdriver in the slot of the rear axle (it should be located on the left side of the car) then turn the right rear wheel clockwise to tighten or anti-clockwise to loosen. When tightening make adjustment of no more than $\frac{1}{4}$ turn at a time.

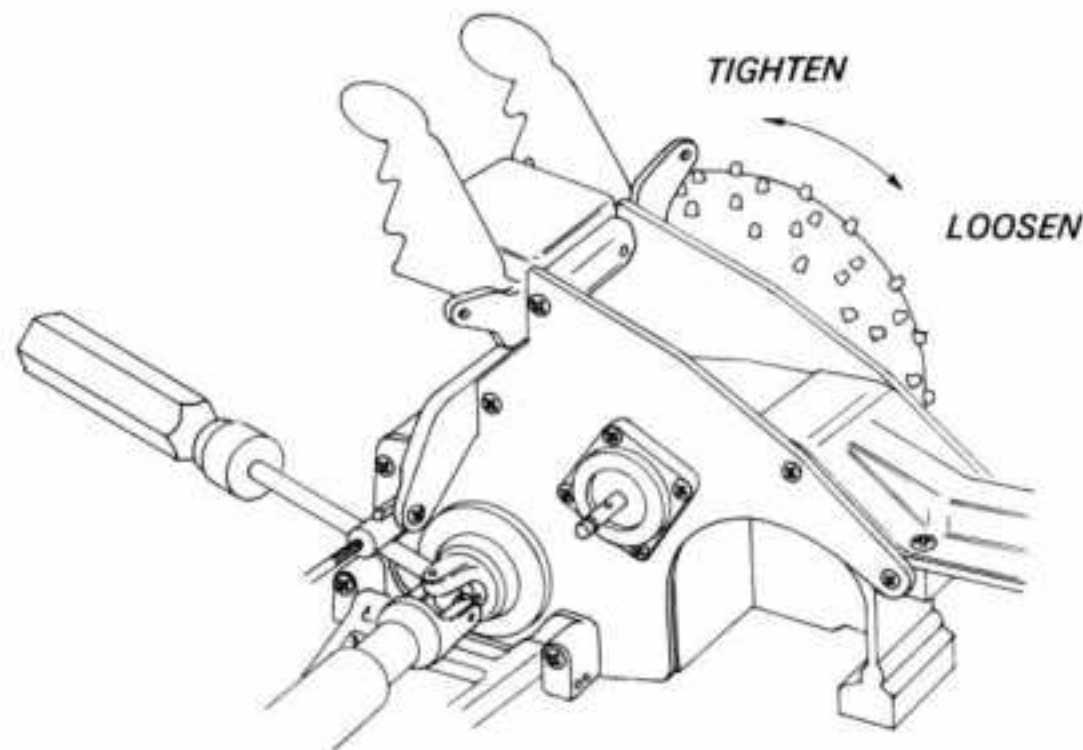

ADJUSTMENT OF DIFF WHEN AT TRACK

- 3) **Belt Adjustment:** If correctly assembled and adjusted as shown in Transmission Assembly step 9 it is most unlikely that trackside adjustment will be required. Never run with a slipping belt as both pulleys and belt can be damaged. Belt slip sounds like a tearing noise when the throttle is opened wide. Always recheck differential adjustment first as in Paragraph 2 because differential slip and belt slip sound very similar. To adjust belt tension, refer to transmission assembly, step 9.
- 4) **Camber**
The rear wheel should be set at 1-2 deg. negative camber. This means that the tops of the wheels lean inwards when viewed from the rear. Adjustment is carried out by turning the hexagon part of the top link. The left hand thread of the link is nearest the small groove in the hexagon. Turning this end clockwise will increase length and reduce camber, turn anti-clockwise to increase camber.
- 5) **Toe in**
The front track rods are adjustable, similar to the top links at the rear. Set the front wheels up to be parallel to each other when pointing straight ahead.
- 6) **Ride height and suspension drop**
Ride height is the height the car runs at under normal loaded conditions. It can be adjusted by changing the spring spacers fitted on the shock absorbers. Run the lowest ride height that track conditions allow. Suspensions drop is the maximum downward movement of the wheel. It can be adjusted at the rear by fitting washers inside the shock absorbers under the pistons.

7) Rear roll stability

This is governed by the position of the shock absorber mounting point on the wishbone. Maximum roll stiffness occurs when outer most mounting holes are used. Bring shocks inboard to gain maximum rear end grip.

8) Damping

Run the lightest, thinnest shock fluid available so long as wheels do not bounce.

9) Tyres

The T651 rear and T653 front tyres in the kit will give safe predictable handling for normal conditions. However Schumacher CAT range of tyres offer a wide range of options to cover all extremes of operating conditions. The spikes on the tyres may be cut to adjust the handling. If on grass the car turns into corners too tightly, then try cutting down the spikes of the front tyres, or use a lower grip tyre from the chart below. On hard dusty surfaces, try using well worn tyres or cut all spikes down to approximately half height.

Consult the chart for your requirement.

HIGH PERFORMANCE OFF ROAD TYRE GUIDE

PART No.	WET GRASS	DRY GRASS	HARD DIRT	MUD	CARPET	POLISHED FLOOR	TYPE
T650 T652 T654	***	***	**	***	***	**	SOFT STD SPIKE STUD(Fr)
T651 T653 T655	**	**	**	**	***	***	HARD STD SPIKE STUD(Fr)
T658 T660	*	**	**	*	***	***	SOFT MINI SPIKE
T659 T661	*	**	***	*	**	**	HARD MINI SPIKE
T666 T668	**	**	**	**	***	***	SOFT CUT SPIKE(Rr) RIB SPIKE(Fr)
T667 T669	**	***	***	**	**	*	HARD CUT SPIKE(Hr) RIB SPIKE(Fr)
T670 T671	*	*	*	*	***	*	SPONGES T & G
T662 T664	**	**	**	*	***	***	SOFT BLOCKS
T663 T665	**	***	***	*	**	**	HARD BLOCKS
T672 T674	**	**	**	**	***	***	SOFT CUT SPIKE
T673 T675	**	**	***	**	**	**	HARD CUT SPIKE

*** HIGH GRIP

** MEDIUM GRIP

* LOW GRIP

10) Gear ratios for 5 minute Race Duration

Pinion	Gear	Pinion to gear Ratio	Overall ratio	Approx. motor wind	
19	95	5.000	12.14	14T	
19	92	4.942	11.99		
19	89	4.684	11.36	15T	
19	86	4.526	10.99		
22	95	4.318	10.48		
22	92	4.182	10.15	17T	
22	89	4.045	9.80		
22	86	3.909	9.49		
25	95	3.800	9.23	19T	
25	92	3.68	8.94		
25	89	3.56	8.64		
25	86	3.44	8.35	21T	
28	95	3.393	8.23		
28	92	3.286	7.99		
28	89	3.178	7.72	27T	
28	86	3.071	7.45		



Dont forget car performance also depends on tyre diameter.

Most tyres are 85mm in diameter but minispikes are 78mm diameter and need a reduction of approximately 10% on overall ratio to give the same car performance. In general cars run longer with smaller pinions. Excessively large pinions, particularly with hot i.e. low wind motors can cause overheating and damage. The gear ratio required will vary with race duration and track condition so you must experiment for best results.

11) Lubrication

All bearings must be lubricated, especially during wet weather. Always remove bearings and clean after running in wet conditions. A533 ballraces may be cleaned by carefully removing the seals with a knife blade under the outside edge and pressed back into place after cleaning. Black contact seals may be removed to reduce drag in clean conditions. **WARNING:** Some aerosol oils and degreasers will expand bearings seals causing drag. Plastic parts should not be lubricated. Drive belts **MUST NOT** be lubricated. Ball differentials and thrust races should only be lubricated with silicone grease.

12) General

In general the car should understeer - this means the front wheels slide more than the rear wheels during cornering. You can get this by cutting the spikes of the front tyres down. It helps to have two or three sets of front tyres with different levels of spikes to test for the best option.

Run the lowest ride height that track conditions will allow - a low car always corners better than a high car. Use the softest damper settings that stop the wheels from bouncing. It is very easy to over damp the car and cause bouncing at speed.

Bag No.	Spares No.	Part No.	Description	No off
T555J	U555K		Shock Absorbers	
		T059A	CAP shock absorbers	4
		T060B	Shock body 16mm	2
		T061C	Shock body 32mm	2
		T133W	Susp. spring 0.045 x 11 x 2.5 Fr.	2
		T132V	Susp. spring 0.045 x 8 x 1.5 Fr.	2
		T062D	Piston rod - 16mm stroke	2
		T063E	Piston rod - 32mm stroke	2
		T117G	Spacer tube 25mm	1
		T239U	Rose joint - ball	4
		T238T	Rose joint - socket	4
		A039N	St. st. screw M3 x 16mm cap hd	2
		A038M	St. st. screw M3 x 12 cap hd	2
		A051Z	Nyloc nut M3	2
		A048W	Steel nut M3	2
	U614K	T614J	Shock absorber seals (set 4)	
		T158V	Bush - shock absorber	(4)
		T159W	Seal housing - shock absorber	(4)
		A230W	Stepped washer	(2)
		A208A	Nylon washer M3 x 0.8mm	(2)
		T162Z	Diaphragm, shock absorber PG9113	(4)
		A103Z	'E' clip 1/8 (0.012 thick)	(12)
		A185D	'O' ring 5.1 x 1.6mm Nitrile	(4)
		A181Z	'O' ring 1/8 x 1/16 silicone	(8)
		A209B	Nylon washer 3.3/3.2 x 7.7/7.8 x 0.8	(4)
		A131B	Int. circlip 8.0 x 0.39mm	(4)
	U613J	T613I	Spring stop & spacer moulding	
		T090F	Spring stop	(4)
		T092H	Spring spacer 1mm	(4)
		T093I	Spring spacer 2mm	(4)
		T094J	Spring spacer 4mm	(4)
		T095K	Spring spacer 8mm	(4)
	U637H	T637G	Shock pistons (set 4)	
		T096L	Shock absorber piston (1sq. mm hole)	(2)
		T097M	Shock absorber piston (2sq. mm hole)	(2)
T580I			Transmission	
	U517R	T517Q	Bearing housing moulding	
		T038Y	Bearing housing diff. closed	(1)
		T081W	Bearing housing rear eccentric	(2)
		T082X	Bearing - housing diff. open	(1)
		T098N	Steering lever	(2)
		T099O	Radius Arm	(2)
	U518S	T518R	Bracket Moulding	
		T056X	Bracket A - front susp.	(2)
		T057Y	Bracket B - front susp.	(2)
		T076R	Mounting bracket	(4)
		T101Q	Servo mount	(2)
	U630A	T601W	Drive shafts - 4WD - moulded parts	
		T027U	Drive shaft - inner	(2)
		T078V	Drive shaft - outer	(2)
		T030X	Wheel hub	(4)
		T031Y	Rear hub	(4)

Bag No.	Spares No.	Part No.	Description	No off
	U640K	T640J	One way drive shafts	1 pr
		T649S	XL drive belts	
		T129S	80/072/5 belt	(2)
		T152P	XL drive belt 80/323/4	(1)
		T759F	Rear trans. housing assembly	
		T072N	Cover plate	(1)
		T073O	Motor plate	(1)
		T070L	Rear trans. housing - inner	(1)
		T293A	Rear trans. housing - outer	(1)
	U610G	T610F	Pulley set	
		T173K	Diff. pulley (14 ball) 51 T	(2)
		T278L	Pulley 21 T	(2)
		T279M	Flange (layshaft) - ballrace	(2)
		T280N	Flange (layshaft) - plain bearing	(2)
		T174L	Drum diff. side pulley 51 T	(2)
	U608E	T608D	Front trans. housing set	
		T055W	Front transmission housing	(2)
		T292Z	Front trans. adj. bar	(1)
		T754A	Ball bearing pack	
		A533N	Ball bearing 8 x 16 NF seal/shield	(12)
		A520A	Thrust race 1/8 x 5/16	(2)
		A532M	Ball bearing 8 x 12 Fl. stainless	(2)
		T758E	Diff. repair kit	
		T118H	Washer carrier - large	(4)
		T243Y	Friction paper 3/8 x 13/16	(4)
		A154Y	Disc spring 1/8 x 0.23 x 0.012	(4)
		A405P	Pin 2.0 dia x 7.8mm	(3)
		A220M	Thrust washer 3/8 x 13/16 x 1/32	(4)
		A500G	Steel ball 3.0mm dia	(30)
		G301N	Silicone grease - tube	(1)
		T753Z	Trans. Assy - small parts	
		T084Z	Rear axle	(2)
		T277K	Layshaft - 3 holed	(1)
		T229K	95 T gear - 48 D.P.	(1)
		T234P	22 T pinion - 48 D.P.	(1)
		A301P	Screw selftap No. 2 x 3/16 pan hd	(17)
		A305T	Screw selftap No. 2 x 1/2 pan hd	(6)
		A323L	Screw selftap No. 4 x 3/8 pan hd	(34)
		A324M	Screw selftap No. 4 x 1/2 pan hd	(6)
		A336Y	Screw selftap No. 4 x 3/4 pan hd	(4)
		A225R	Steel washer M3	(3)
		A035J	St. st. screw M3 x 6 cap hd	(2)
		A501Z	Nyloc nut M3	(6)
		T108X	U/J pivot assembly	(8)
		T131U	U/J assembly tool F/G	(1)
		A180Y	'O' ring 1/8 x 1.16 Nitrile	(1)
		A141L	Socket wrench 1.5mm A/F	(1)
		A143N	Socket wrench 2.5mm A/F	(1)
		A206Y	Nylon washer 3.3 x 8.0 x 1.6	(4)
T582K	U582L		Instruction book set - Pro-Cat	
		T298F	Decal sheet - 4WD - 4 colour	1

Bag No. Used in kits
Spares No. Available for sale.

Part No. Stores number only, not saleable.
No. Off. Bracketed number is quantity in each sub assembly.

The Secret of Success ...the wraps are off!

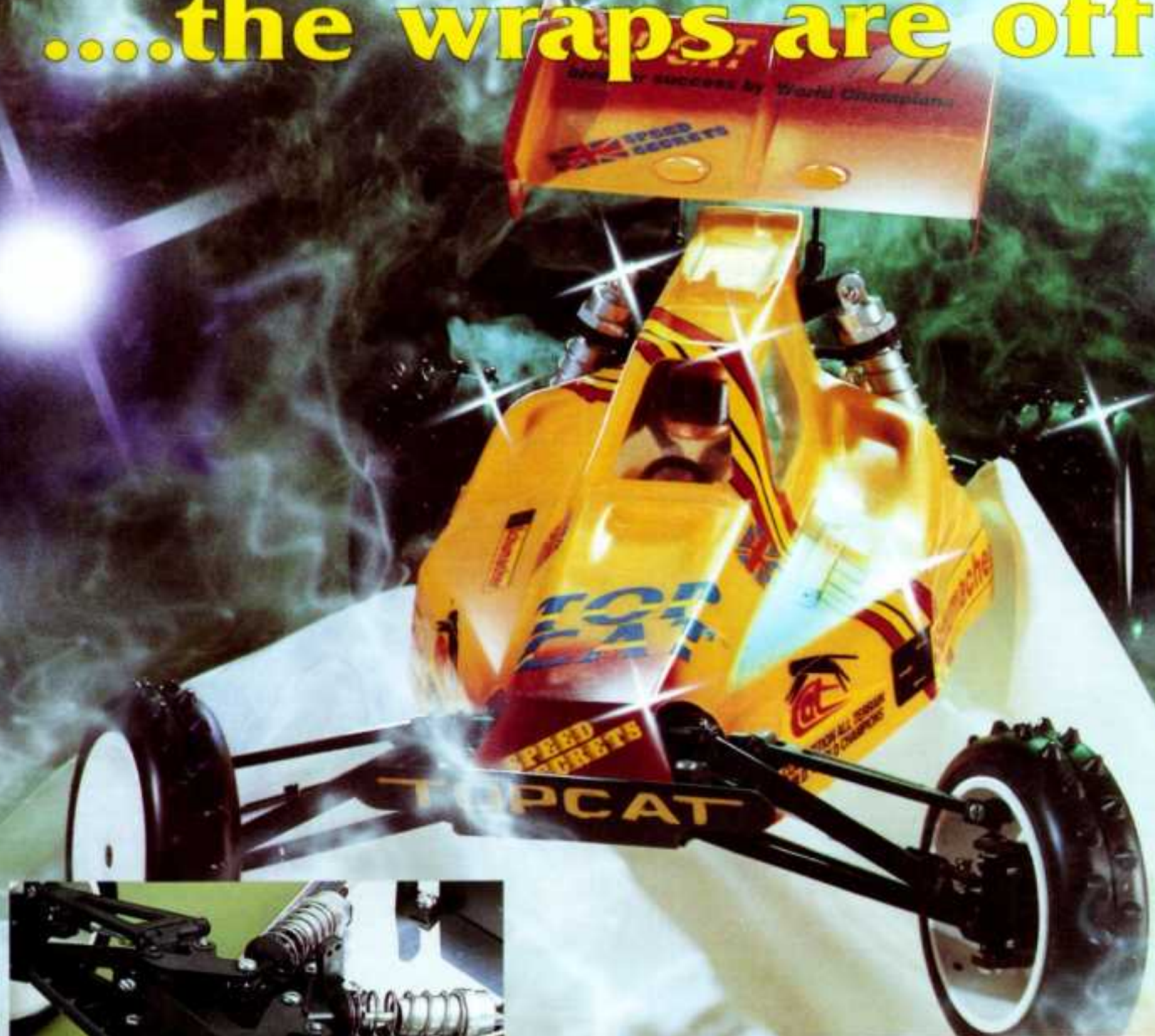

FRONT SUSPENSION.

The Topcat features inboard coil over shocks operated by double unequal length wishbones with the unique 'CRASHBACK' facility.

The all new



TOP CATTM

bred for success by World Champions

TOPCAT 2 W.D. OFF-ROAD RACER

Now, from the team that designed the world's most successful 4 W.D. off-roader, comes a new challenger for 2 W.D. honours. The Topcat uses many innovative features to leave the opposition far behind. The secret of success is now revealed, see it, buy it, be part of it!

SCHUMACHER - 4 W.D. WORLD CHAMPIONS, US NATIONAL CHAMPIONS

DISTRIBUTED TO LEADING HOBBY SHOPS
NATIONWIDE EXCLUSIVELY BY:



Racing Products Limited

Performance and technology that YOU CAN BUY!

