

# TENFORCE

## Instruction Manual

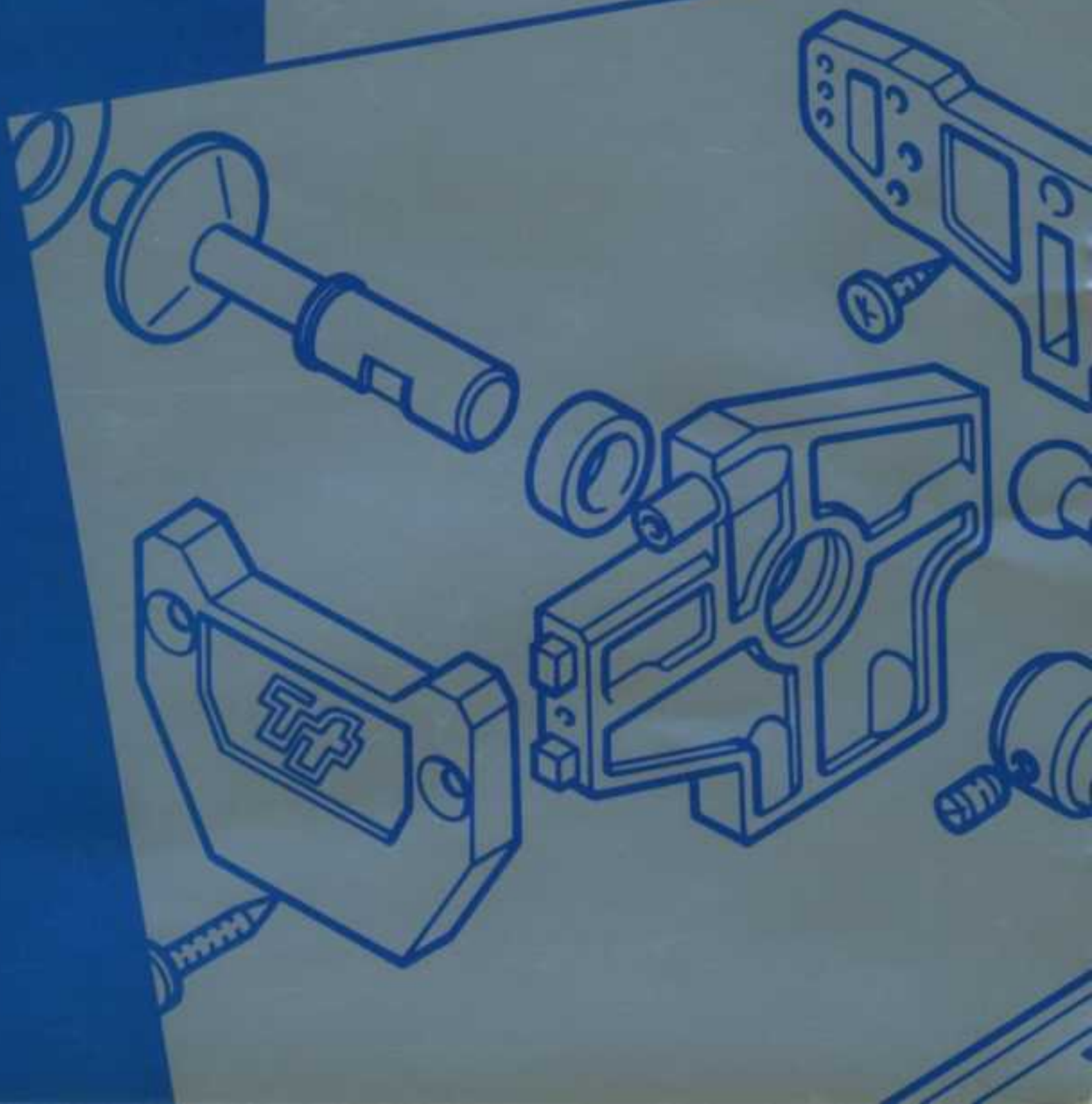

# 0 1 - F S B

## ***BERTON***

## Introduction

In the building instructions the required fasteners are defined with a number placed in a circle. Use the FASTENERS REFERENCE LIST to select the right fastener.

### FASTENERS REFERENCE LIST:

Fastener nbr.	type		head style	quantity
A	metric screw	M2x6	r.h.	2
B	metric screw	M2x8	r.h.	6
C	metric screw	M3x8	c.s.h.	10
D	metric screw	M3x10	s.h.	2
E	metric screw	M3x25	s.h.	1
F	grub screw	M3x4	sl.h.	2
G	grub screw	M3x4	s.h.	1
H	grub screw	M4x4	s.h.	2
I	parker screw	2.9x6.4	r.h.	8
J	parker screw	2.9x9.5	r.h.	8
K	parker screw	2.9x9.5	c.s.h.	17
L	parker screw	2.9x13	r.h.	4
M	parker screw	2.9x13	c.s.h.	4
N	washer	3.2x7		4
O	washer	4.2x12		2
P	lock-nut	M3		2
Q	lock-nut	M4		2
R	cir-clips	4mm		4
S	hardened pin	2x12		4
T	hardened pin	3x24		2
U	hardened pin	3x28		2

## Head styles

r.h.	round head
c.s.h.	counter sunk head
sl.h.	slotted head
s.h.	socket head

## Assembling the front suspension

- 1** Fit the brass balls to the steering blocks using screw (B) and push the front wheel axles in the steering blocks.
- 2** Mount the king-pin to the lower suspension arms by inserting the hardened pivot pins (T). Lock them with grub screws (F).
- 3** Put the steering blocks over the king-pins, and lock them with circlips (R).
- 4** Mount the 5mm pivot balls on the inner holes of the front bracket, with screw (B).
- 5** Apply caster spacer #3 to the chassis and mount the front bracket to the chassis with the parker screws (L).  
Next the 4 pivot balls are mounted to the chassis with screws (C).
- 6** Push the lower suspension arms over the pivot balls and check that they are free.
- 7** Insert the anti-rollbar rods through the nylon anti-rollbar mounts and fix them to the lower suspension arms using parker screw (J) in the mounts and (I) in the 2 slots. The 2 anti-roll bars should hook-in.

Note: moving the nylon mount to the inside of the car will stiffen up the anti-roll bar and will cause less roll. This will normally decrease the steering.

- 8** Prepare the upper front suspension rods (total length 59.5mm) and apply them to connect the steering block with the front bracket. By shortening the upper rods the camber angle will become more negative.

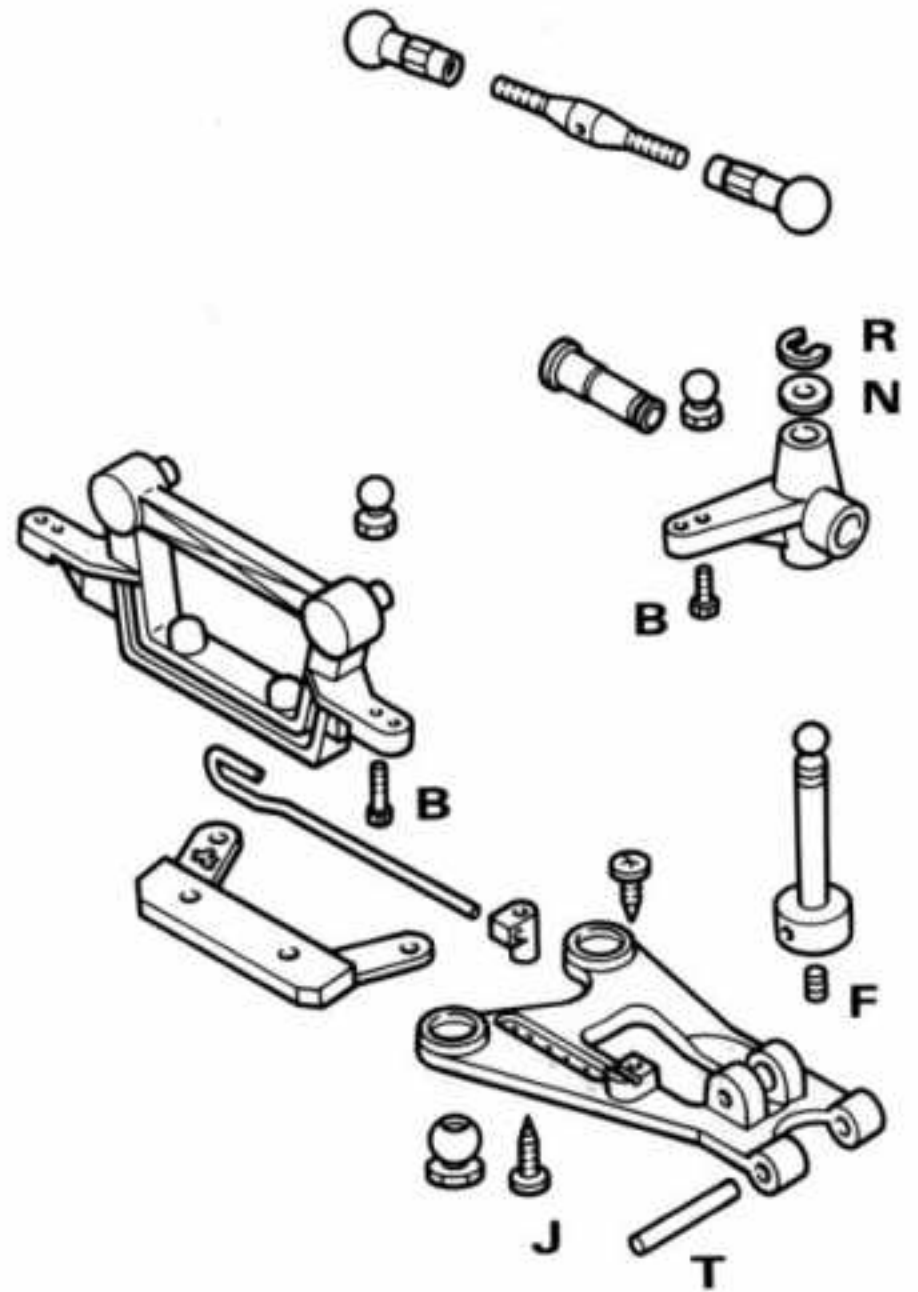

## Assembling the ball differential

- 1** Push the pulley flange into the differential pulley and insert the steel diff. balls in the holes of the differential pulley. Apply some grease to the balls and the centre hole of the pulley.
- 2** Place the hardened steel washer on the long axle, next the diff. pulley, the second hardened steel washer, the nylon 5mm bearings and last the short diff. axle.
- 3** The small thrust bearing is inserted, and together with the spring washers the diff. tension adjustment screw (E) is screwed in to apply the necessary load to the differential.

### Note:

Check the smooth running of the differential. Under full load the differential should not slip. This should be checked before running the car. Hold the 2 rear wheels and apply full throttle for just 1 second. The diff. pulley should not slip. If it does, apply a little more load to the diff. by turning in the adjustment screw a little bit.

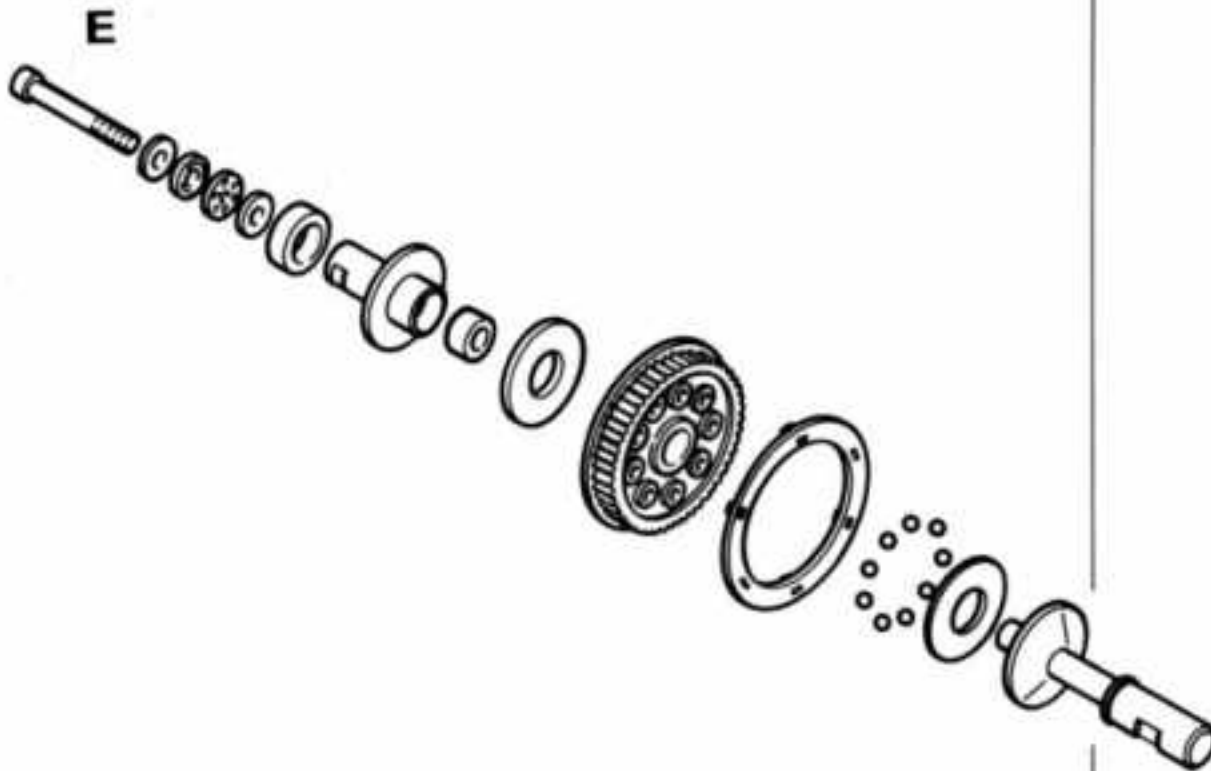

## Assembling the rear suspension

- 1** Insert the 5mm ballbearings in the uprights, and mount the pivot balls using screw (B).
  - 2** Mount the up-rights to the lower rear suspension arms by inserting the hardened pivot pins (U).
  - 3** Mount the rear anti-rollbar rods to the lower arms using the nylon mounts and parker screws (J). Use the middle hole. Fix it to the slot with parker screw (I).
- Note: moving the nylon mount to the inside of the car will stiffen up the anti-roll bar and will cause less roll.
- 4** Fix the 4 pivot balls to the chassis using screws (C).
  - 5** Push the lower arms over the balls and check the free movement. The anti-roll bar rods should hook in.
  - 6** Push the 8mm ballbearings in the diff. blocks and place the mounted differential between them. The timing belt should also be applied in this stage.
  - 7** Mount the drive shaft adaptors to the differential, using grub screw (H). Now the differential blocks can be mounted to the chassis with parker screws (K). The rear plate is fixed to the diff. blocks with parker screws (M) and to the chassis with parker screws (K).
  - 8** Mount the pivot balls to the T-bracket with screws (B). The T-bracket is mounted to the motor mounting block with parker screws (I).
  - 9** Screw the T-bracket to the differential blocks with parker screws (J) and the motor mounting bracket to the chassis with parker screws (K). Make sure the timing belt is in place.
  - 10** Prepare the upper suspension rods and adjust it to a total length of 62.5mm.
  - 11** Insert the rear wheelaxles in the up-rights and apply the drive shafts. Place the upper suspension rods over the balls on the T-bracket and the up-rights to complete the rear suspension.
  - 12** Mount the motor mounting and cooling plate to the motor bracket with parker screws (I).

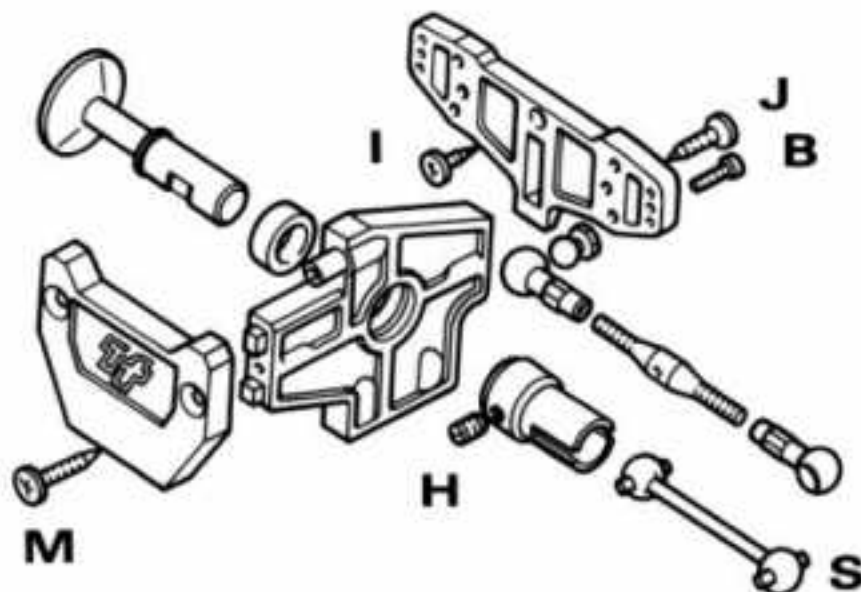
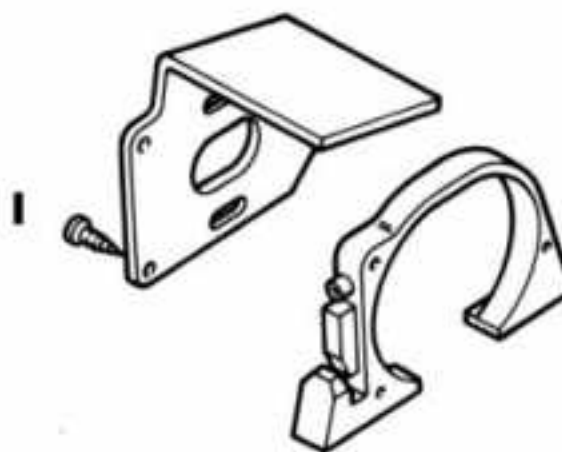
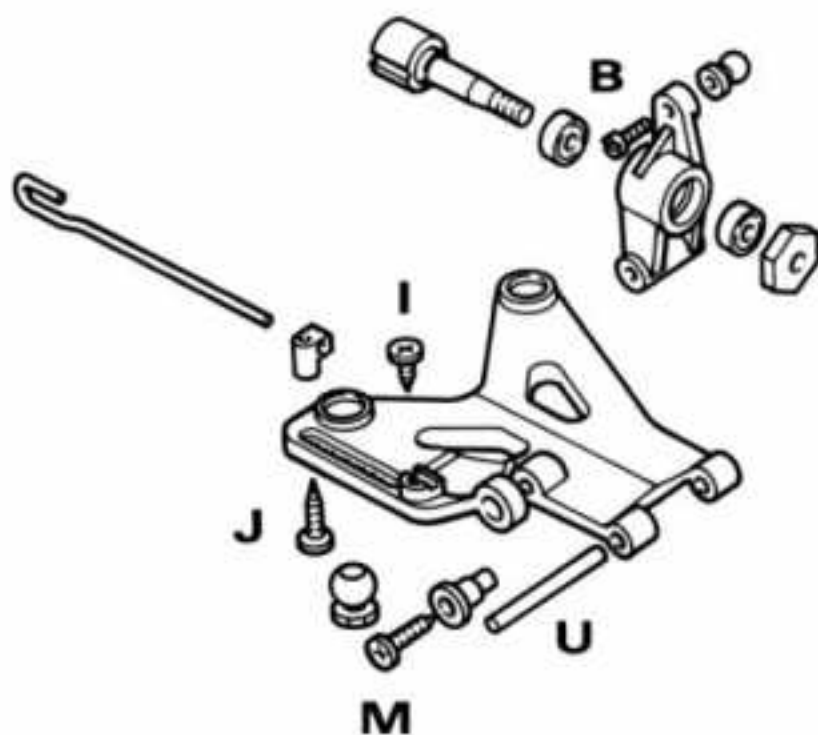

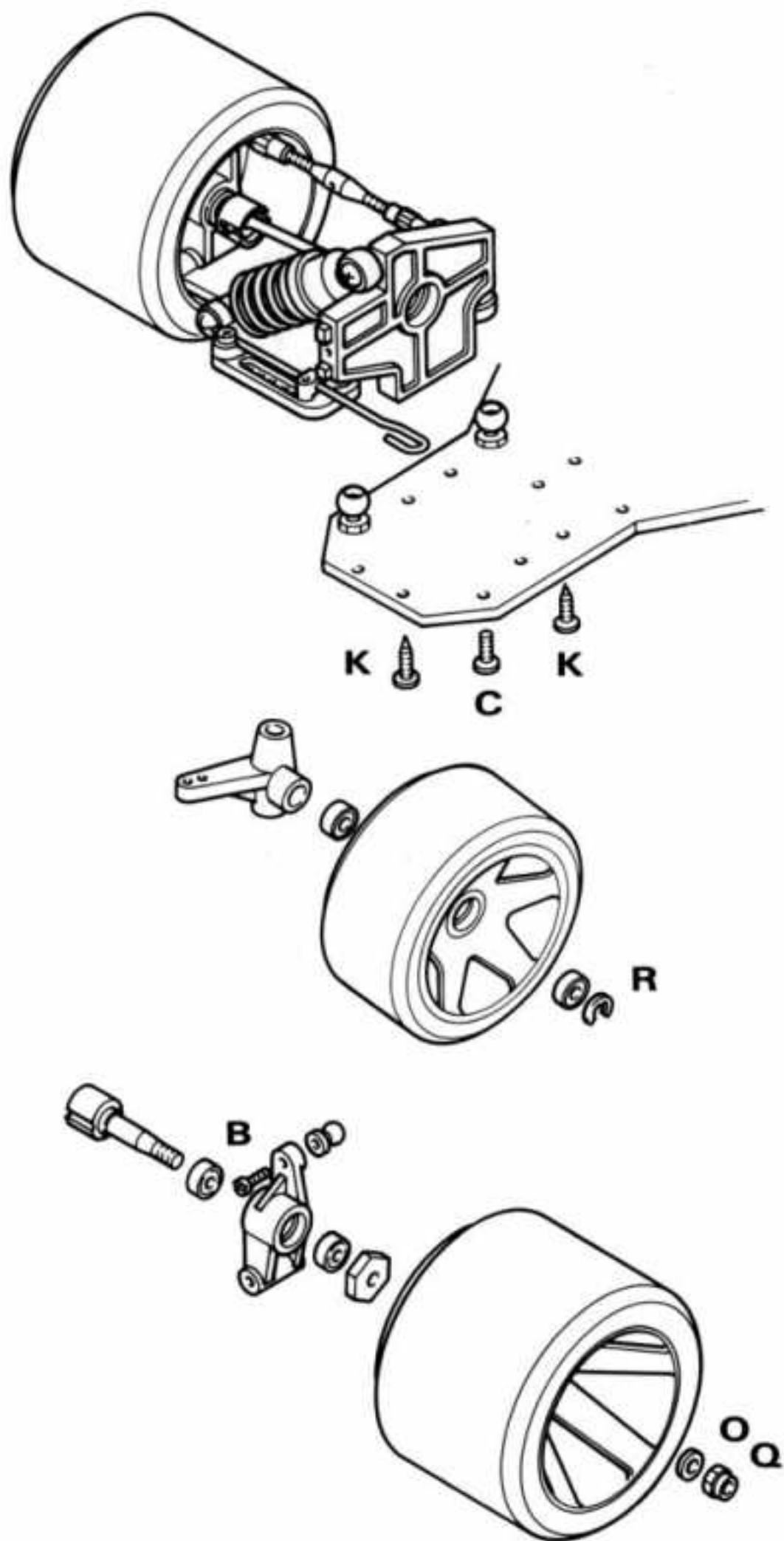

## Fixing the wheels

- 1** After having glued and trued the tires the front wheels are put on the car. First insert the 5mm ballbearings. Secure the frontwheel with circlips (R).
- 2** The hexagon wheelhub is placed on the rear wheelaxle and the rearwheel is mounted with the nylock nut (Q) and washer (O).

## Assembling the shockabsorbers

The TF-01 FSB shockabsorber set features 2 options, fixed non-adjustable pistons and adjustable double pistons.

It is advised to start with the first option because of the easier assembling.

The front and rear shockabsorbers are almost identical. Be aware that the rear piston rods are 4mm longer than the front pistong rods.

### OPTION 1

- 1 Insert C-clips 2.3mm on the second groove of the piston rod and turn the piston on the piston rod. Secure the piston with the small 1.9 C-clips. Proceed with step 5.

### OPTION 2

- 2 Insert C-clips 2.3mm on the second groove of the piston rod and slide the piston with the bigger hole on the piston rod.
- 3 Turn the second piston (small hole) on the M3 part of the piston rod, apply the 1.9mm C-clips and turn the piston back against the C-clips.
- 4 Apply the 7mm O-ring between the 2 pistons. By turning the 2nd piston towards the 1st piston, the O-ring will be squeezed to the outside and will change the flow resistance of the piston.
- 5 Place the O-rings and nylon guide washers in the lower end of the cilinder. The retainer clips is inserted to keep the O-ring pack in place. Make sure the clips is seated well in the groove.
- 6 Insert the pre-mounted piston rod in the cilinder and gently push it through the O-ring pack. Apply a little oil to avoid damage of the O-ring pack. Screw the nylon pivot eye to the rod-end. Be careful not to damage the piston rod.
- 7 Fill the cilinder with shockabsorber oil, with the piston in bottom position. Move the piston slowly up and down to allow air to escape.
- 8 After all the air has escaped the nylon cam-bushing is pressed into the cilinder. Place the rubber compensation membrane in the alu. pivot point and close the cilinder with the piston positioned half-way.

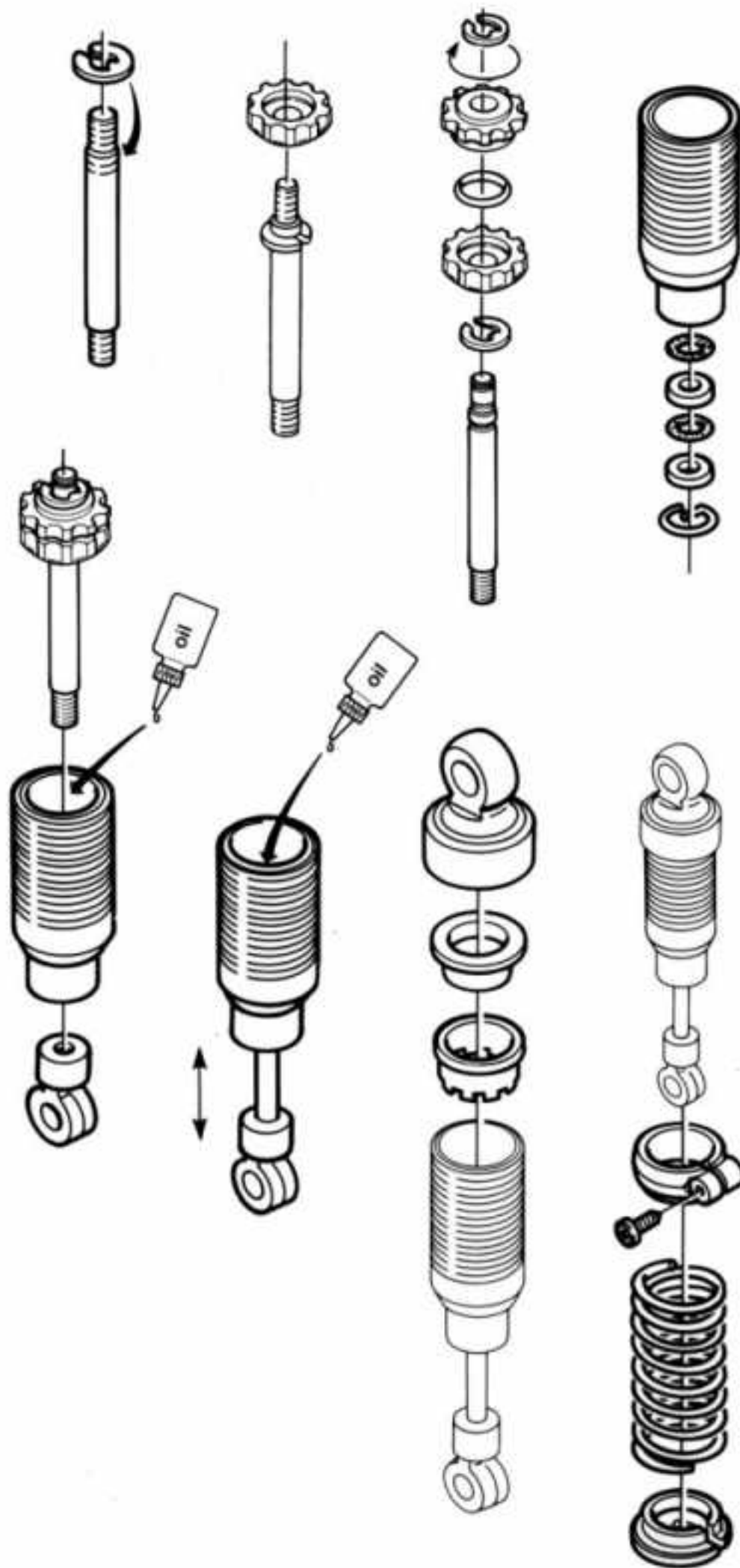

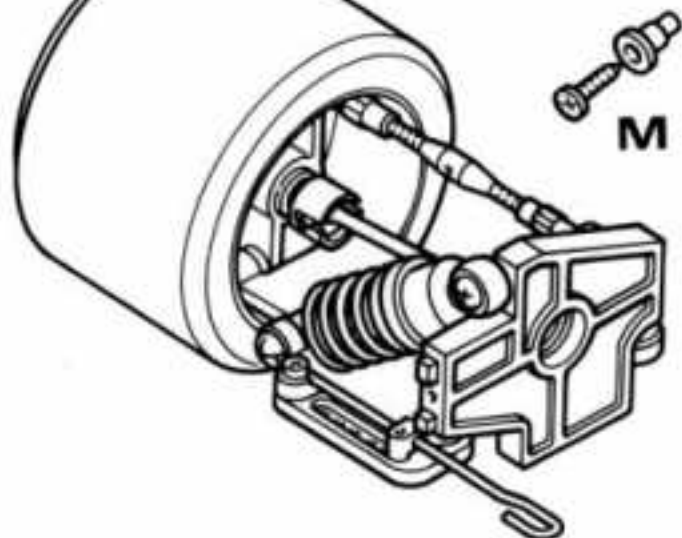
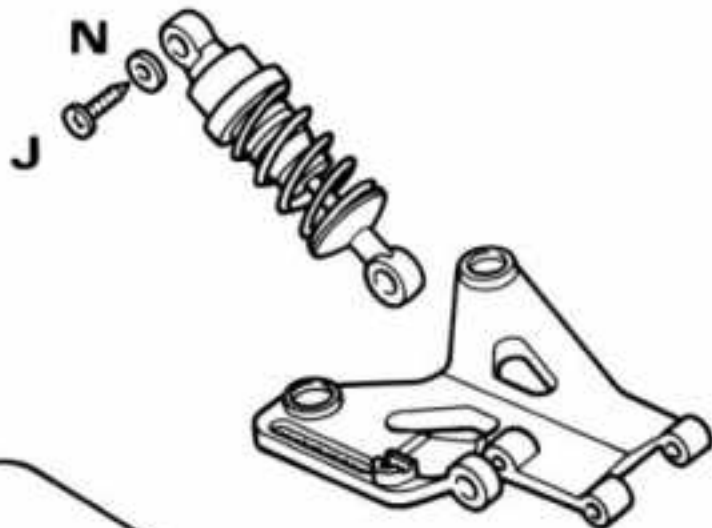
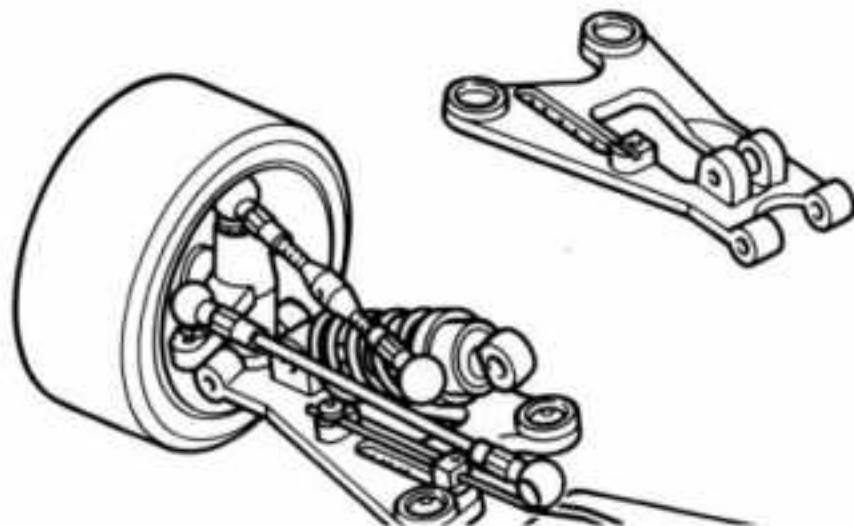
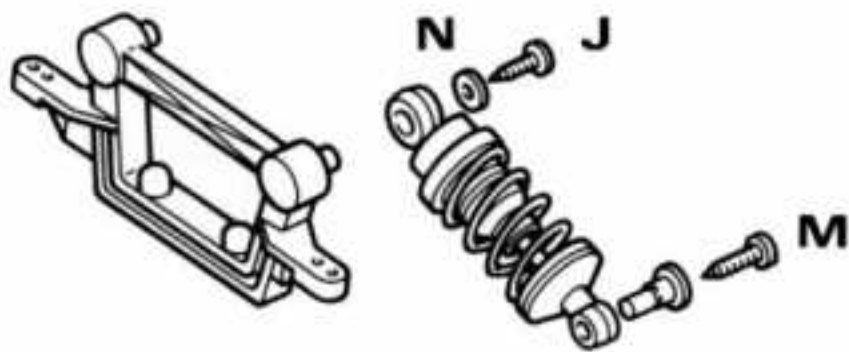

**9** Check the well functioning of the shock absorber. Equalize the right and left shocks by adjusting the pistons. The fronts must be quit heavy, the rears quit light setting. The adjustment is made as follows: push the piston up and snap it into the cambushing. The piston will only reach the cam when the spring support washer is removed. Turn the piston rod in to obtain heavier damping, and out to obtain lighter damping.

**10** Apply the nylon spring adjustment ring to the cilinder. The r.h. parker 2.2 x 9.5 is used to tighten it. Place the coilspring on the shockabsorber and apply the slotted nylon spring support.

**11** Place the front shocks between the front bracket and the lower suspension arms and fix them with parker screws (J) and washer (N) in the bracket using the nylon bushing and parker screw (M).

**12** In the same way the rear shockabsorbers are mounted.

**13** Fine tuning of damping and spring-pressure can only be done at track-side and depends on track condition and tire choise. Other springs are available for different suspension characteristics.

**Note:**

It is advised to use the special S-Performance Silicon shockabsorberoil as supplied in this kit. Other grades of oil are available.

1681 SILICON OIL GREEN (light)

1682 SILICON OIL YELLOW (medium)

1683 SILICON OIL RED (thick)

1684 SILICON OIL BLUE (heavy)

## Steering assembly

- 1** Repair the track rods and adjust them to create a little toe-in of the front wheels. Making them shorter gives toe-out with more steering and increased instability, longer trackrods create toe-in resulting in less steering and more stability.
- 2** Mount the 2 brass balls to the servo saver, using screws (A). Use the top outer holes. Other holes may be drilled in between these holes to change the steering geometry slightly.
- 3** Mount the pre-mounted servo saver on the steering servo. Add the double sided adhesive tape and position the steering servo with the servo saver exactly in the middle of the car. Make sure that the track rods move freely when steering to the far left and far right.

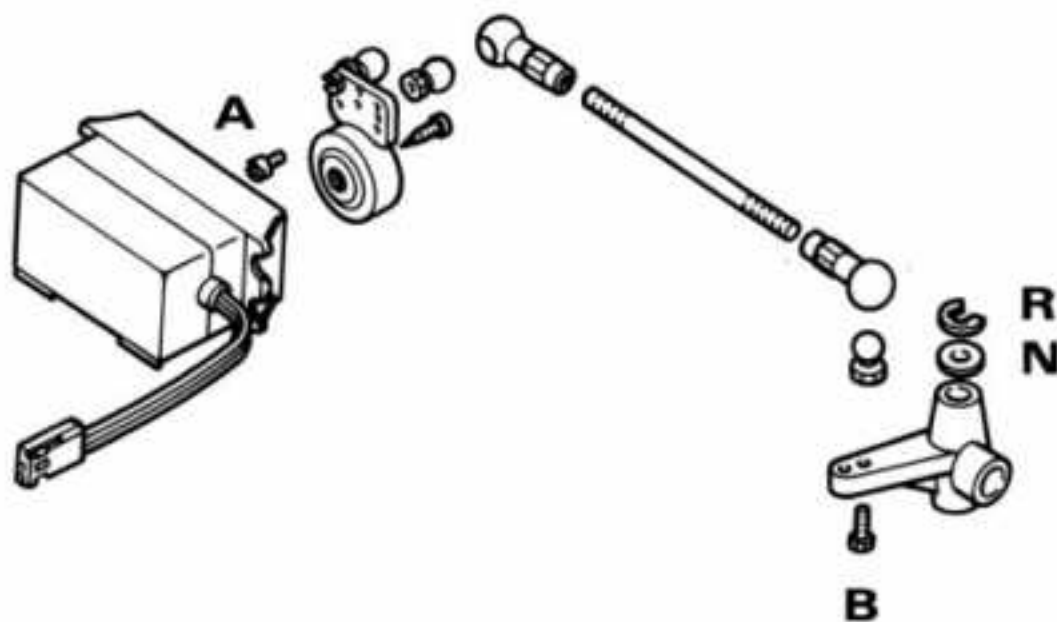

## Bumper and bodymounts

- 1** The front and rear body posts are easy to assemble. Place the spring over the top of the post, apply the washer and pop-in the lever. Open the bodypost gently with a small screwdriver to allow the lever to pop in.
- 2** Mount the front bumper and the front body posts using screws (C) and locknuts (P).
- 3** Mount the bodymount on the bracket in order to get the right body height. Use parkerscrew (I) and washer (N). The bracket is placed over the 2 shockabsorber pivot points of the differential blocks.

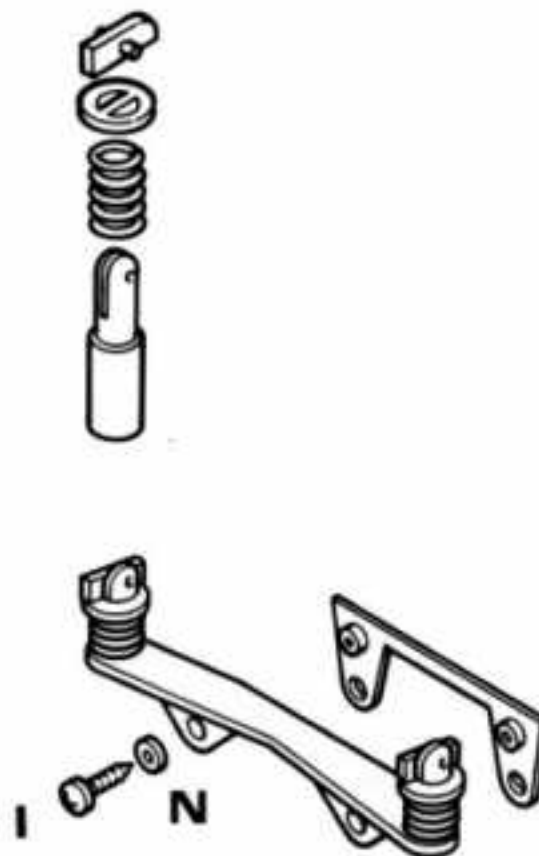

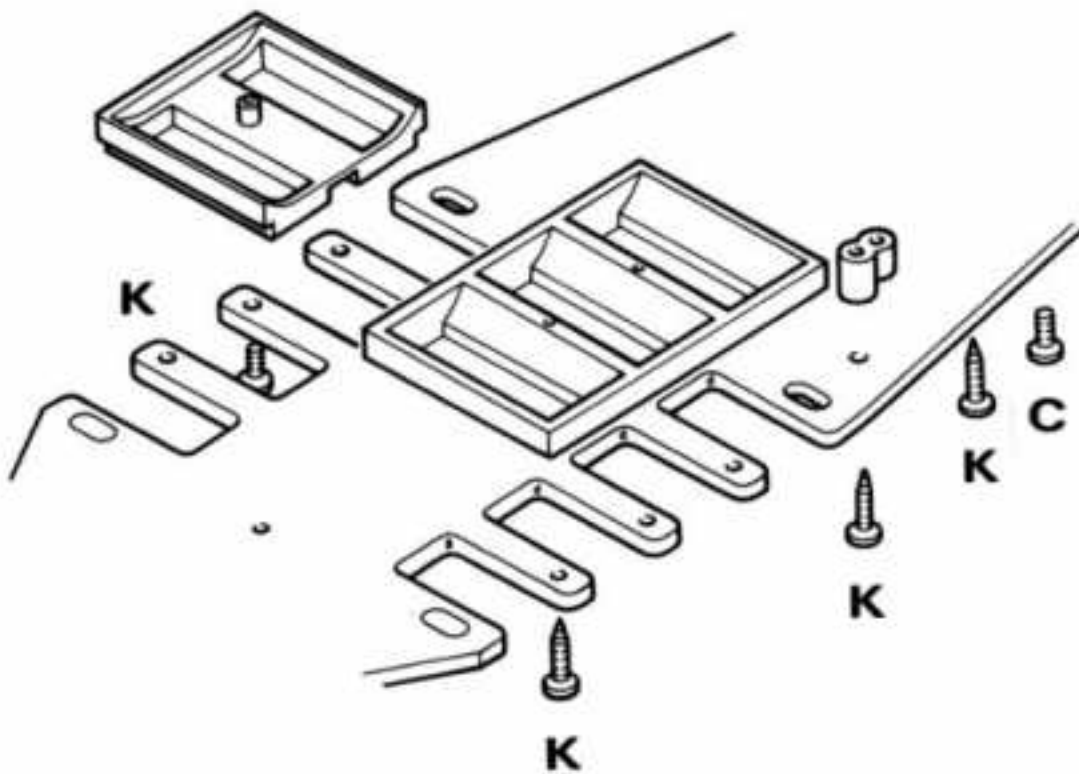

## Battery mounts and antenna

The batteries can be mounted in 2 ways. The saddle-pack position, with 3 cells on each side of the car, or the stick position, with 2 rows of 3 cells across the chassis.

- 1** The saddle packs are mounted with parker screws (K). Choose the front position using the 3 slots towards the front, or the rear position, using the 3 slots towards the rear. This may depend on the track lay-out and conditions, since this position effects the center of gravity of the car, and therewith the handling. To mount the stick-type cells, also parker screw (K) is used.
- 2** Mount the antenna mount to the chassis with parker screw (K).

## Electric motor installation

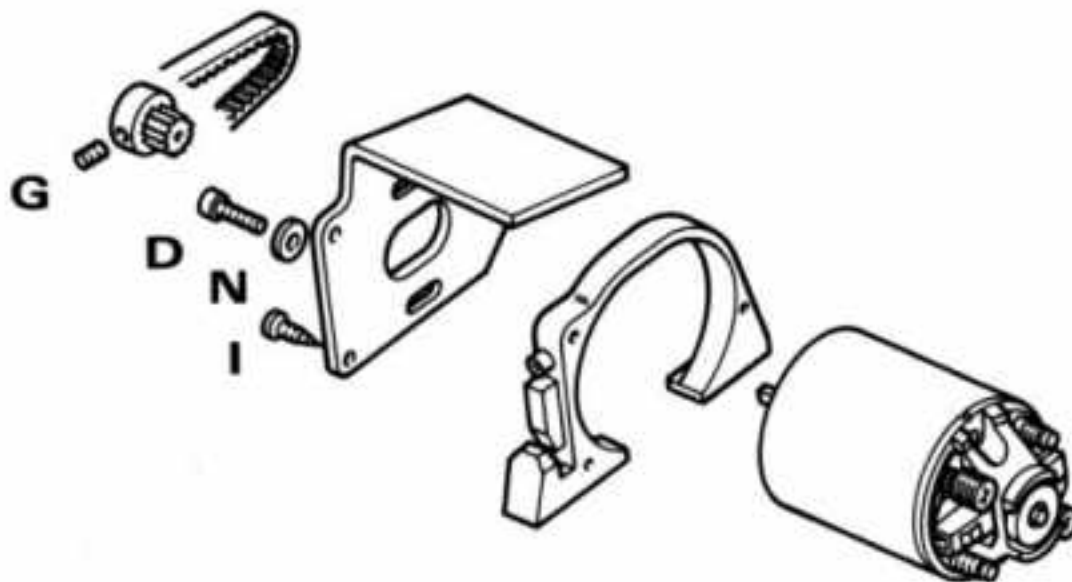

- 1** Mount the alu. motor pinion to the electric motor. It is advised to use a drop of Loctite to secure the small grub screw (G).
- 2** Apply the timing belt to the pinion. The electric motor is fixed to the motor bracket with screws (D) using washers (O). Adjust the right belt tension and tighten the screws.

## Numbers exploded view TenForce TF 01-FSB

1	Chassis aluminium 7075-T6	7101
2	Front-bumper	7102
3	Saddlepack holders	7103
4	Stickpack holders	7104
5	Body mount set (front/rear)	7105
6	Servo-saver 1:10 for all types	7106
7	Trackrod set 5 mm	7107
8	Lower front wishbones	7110
9	Steering blocks	7111
10	Front bracket	7112
11	Caster spacers 4 PCS	7113
12	Upper arm set front/rear	7114
13	Ing-ping set (2)	7115
14	Front pivot pens and balls	7116
15	Front- wheelaxles (2)	7117
16	Anti-rollbar set front/rear	7118
17	Lower rear wishbones	7130
18	Up-rights	7131
19	Differential blocks	7132
20	Front & rear plate rear transm	7133
21	Motor bracket/cooling plate	7134
22	Rear pivot pins and balls	7139
23	Rear wheels axes	7140
24	Wheelbearing set (4)	7142
25	Drive shafts	7143
26	Differential set	7150
27	Main differential axes	7151
28	Thrust bearing washers & balls	7152
29	Slotted adaptors 1:10	7153
30	Differential bearings (8x12)	7154
31	P-2 kevlar timing belt 190T	7155
32	P-2 kevlar timing belt 200T	7156
33	P-2 diff. pulley 67 T	7167
34	P-2 diff. pulley 70 T	7170
35	P-2 diff. pulley 73 T	7173
36	P-2 motor pinion 12 T	7182
37	P-2 motor pinion 13 T	7183
38	P-2 motor pinion 14 T	7184
39	P-2 motor pinion 15 T	7185

40	P-2 motor pinion 16 T	7186
41	P-2 motor pinion 17 T	7187
42	P-2 motor pinion 18 T	7188
43	Set of 2 shockabsorbers front	7200
44	Plastic shock. parts	7201
45	Cilinders shockabsorber (2)	7202
46	Revision set (2 front shocks)	7203
47	Set of soft springs	7204
48	Set of medium springs	7205
49	Set of hard springs	7206
50	Set of 2 shockabsorbers rear	7207
51	Revision set (2 rear shocks)	7208
52	Alu. pivot points	7209
53	Alu. adjusting nuts	7210
54	Front wheels (2)	7710
55	Rear wheels (2)	7720
56	SUMO front tyres soft	7800
57	SUMO front tyres medium	7801
58	SUMO front tyres hard	7802
59	Rear tyres soft	7810
60	Rear tyres medium	7811
61	Rear tyres hard	7812
62	Body Porsche 962	7850
63	Body Sauber Mercedes	7851
64	Body Jaguar group C	7852
65	Body Ferrari F-40	7853
66	Body Nissan GTP 1:10	7854
67	Lexan rear wing 1:10	7890

