

**ROADRUNNER**



**ROAR & NORRCA  
National  
Championships**

# **XPRESS**

**1:10 Touring Car Chassis Kit**

# 1. [ ASSEMBLING DIFFERENTIAL GEAR ]

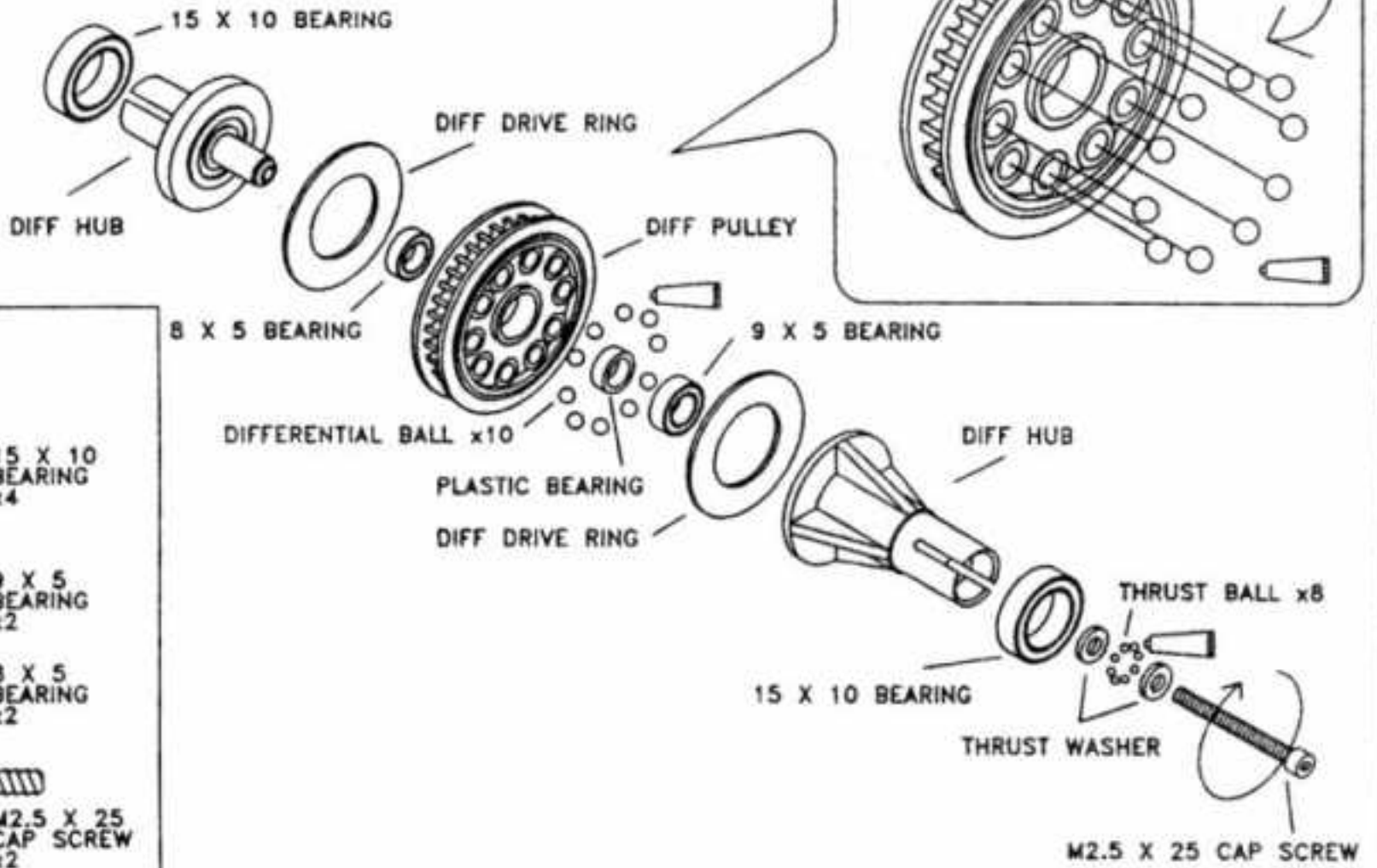

- BAG A-1**
- 15 X 10 BEARING x4
  - 9 X 5 BEARING x2
  - 8 X 5 BEARING x2
  - M2.5 X 25 CAP SCREW x2
- DIFF HUB (LEFT & RIGHT) x2  
 DIFF DRIVER RING x4  
 DIFF PULLEY x2  
 DIFFERENTIAL BALL x20  
 THRUST WASHER x4  
 THRUST BALL x16  
 PLASTIC BEARING x2

# 2. [ ASSEMBLING CENTER SHAFT ]

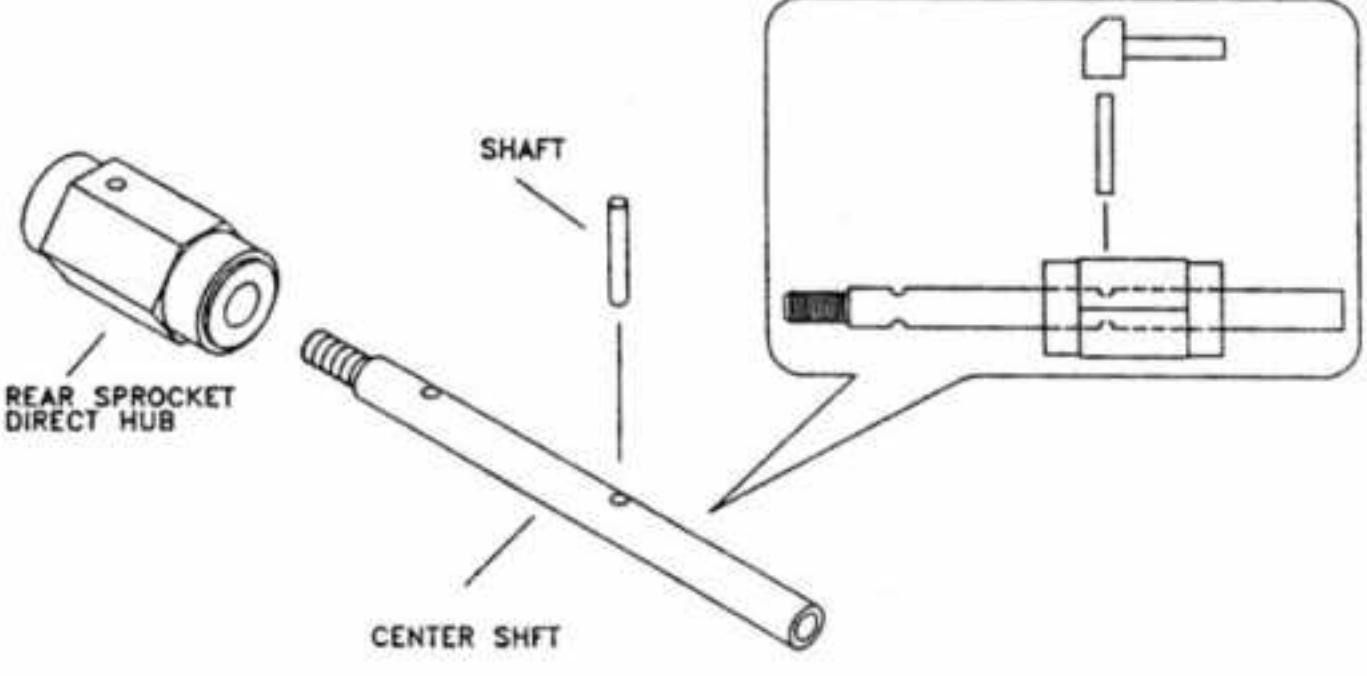

- BAG A-1**
- SHAFT x1
  - SPROCKET DIRECT HUB x1
- CENTER SHAFT x1

# 2.1 [ ASSEMBLING CENTER SHAFT ]

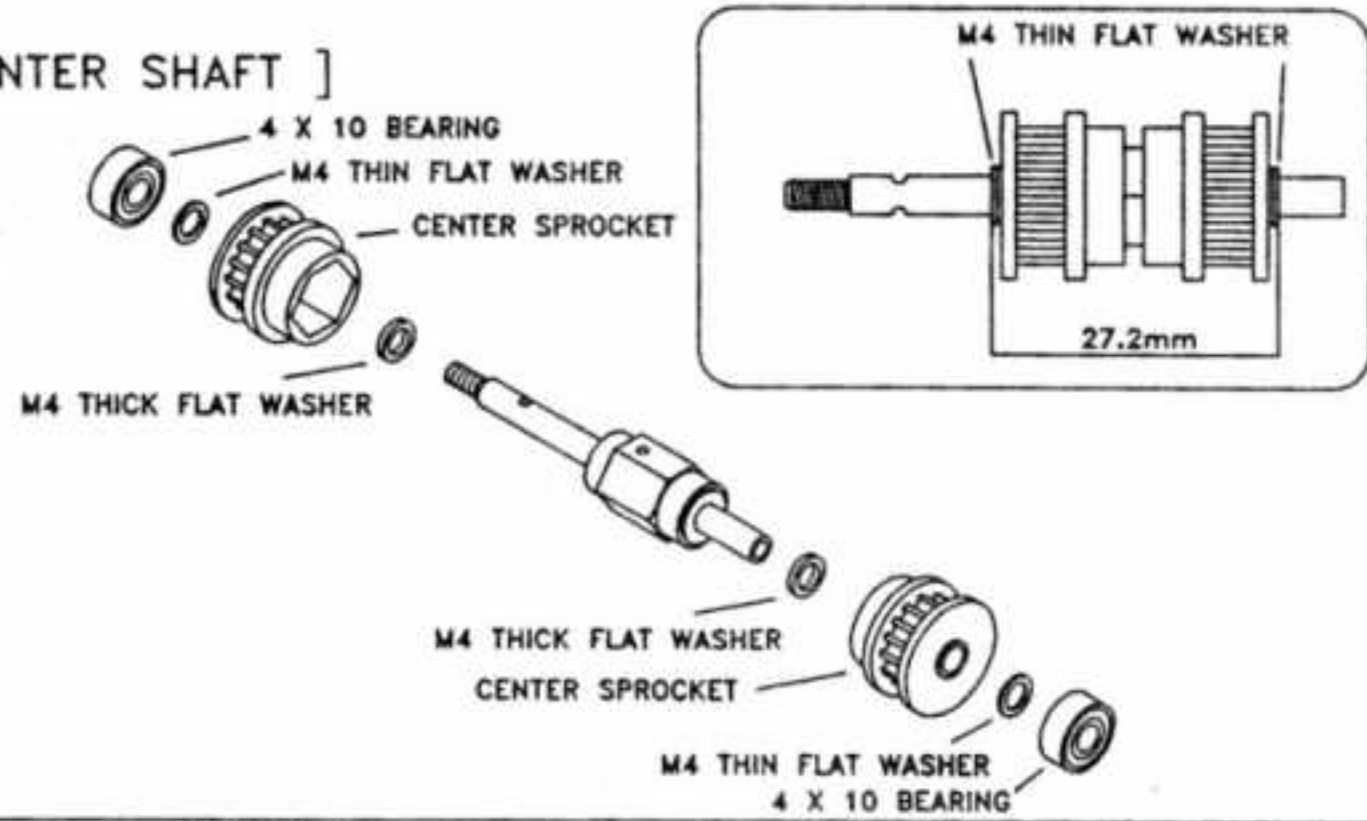

- BAG A-1**
- 4 X 10 BEARING x2
  - M4 THICK FLAT WASHER
  - M4 THIN FLAT WASHER
  - CENTER SPROCKET x2

### 3. [ MOUNTING CENTER SHAFT AND DIFF GEARS ]

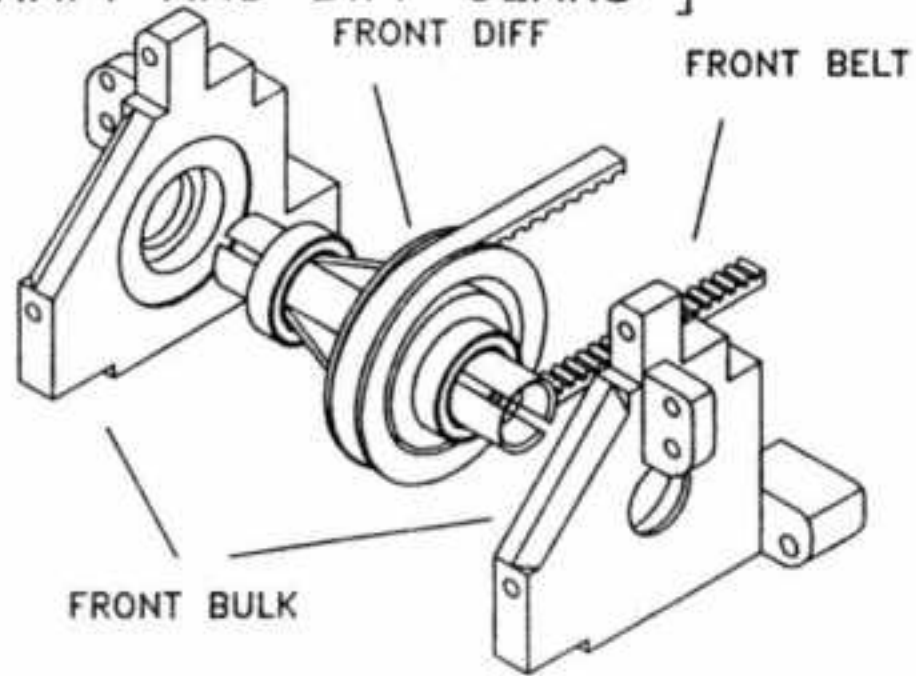

**BAG A-1**

- FRONT BELT x1
- FRONT BULK (LEFT & RIGHT) x1

### 3.1 [ MOUNTING CENTER SHAFT AND DIFF GEARS ]

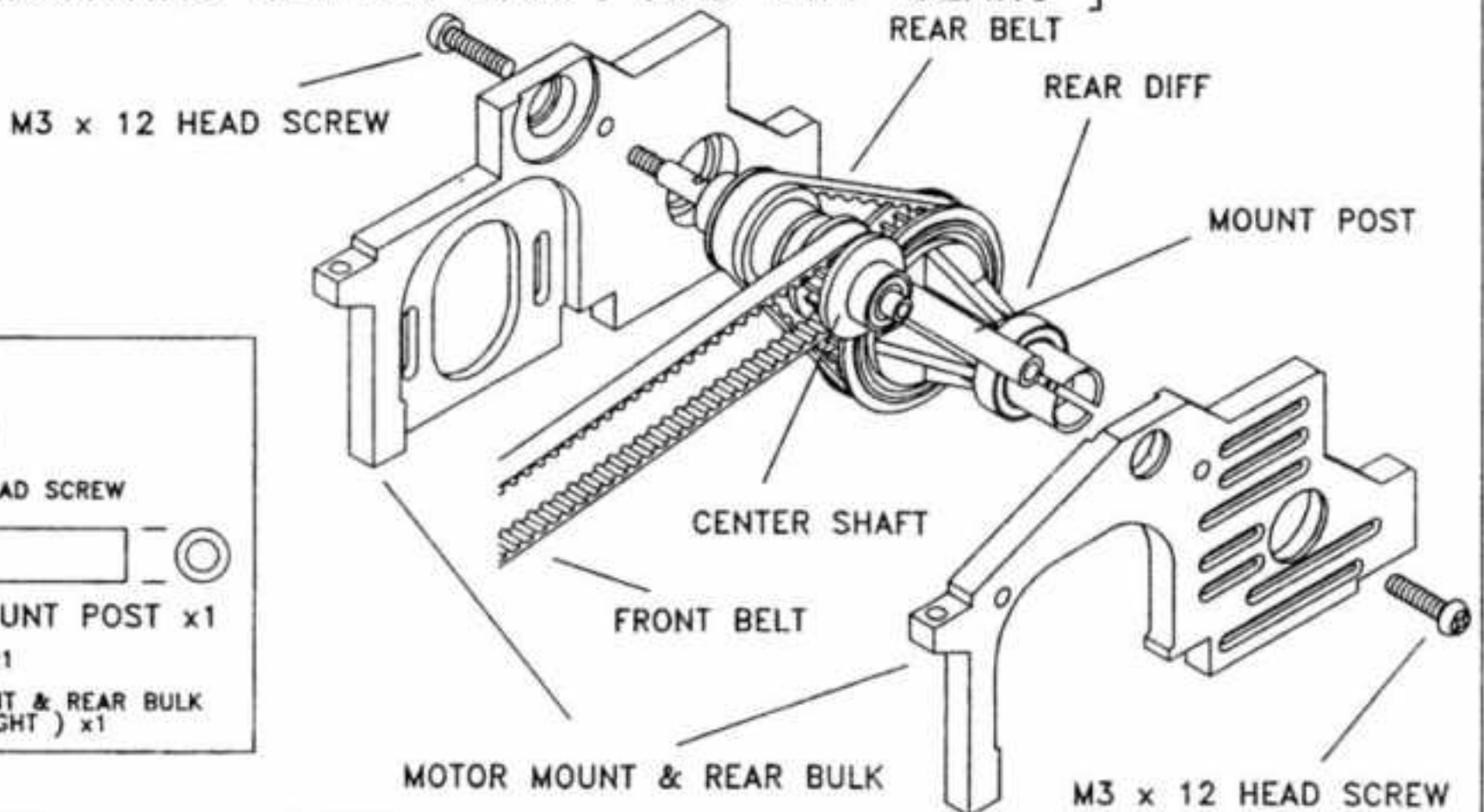

**BAG A-1**

- M3 x 12 HEAD SCREW x2
- MOUNT POST x1
- REAR BELT x1
- MOTOR MOUNT & REAR BULK (LEFT & RIGHT) x1

### 3.2 [ MOUNTING CENTER SHAFT AND DIFF GEARS ]

- BAG A-1**  
REAR LOWER ARM HOLDER x1

- BAG A-2**
- M3 x 8 TAPPING SCREW x 4
  - M3 x 10 SCREW x 6
  - M3 x 16 SCREW x 2
  - POST x 4

- MAIN CHASSIS x1

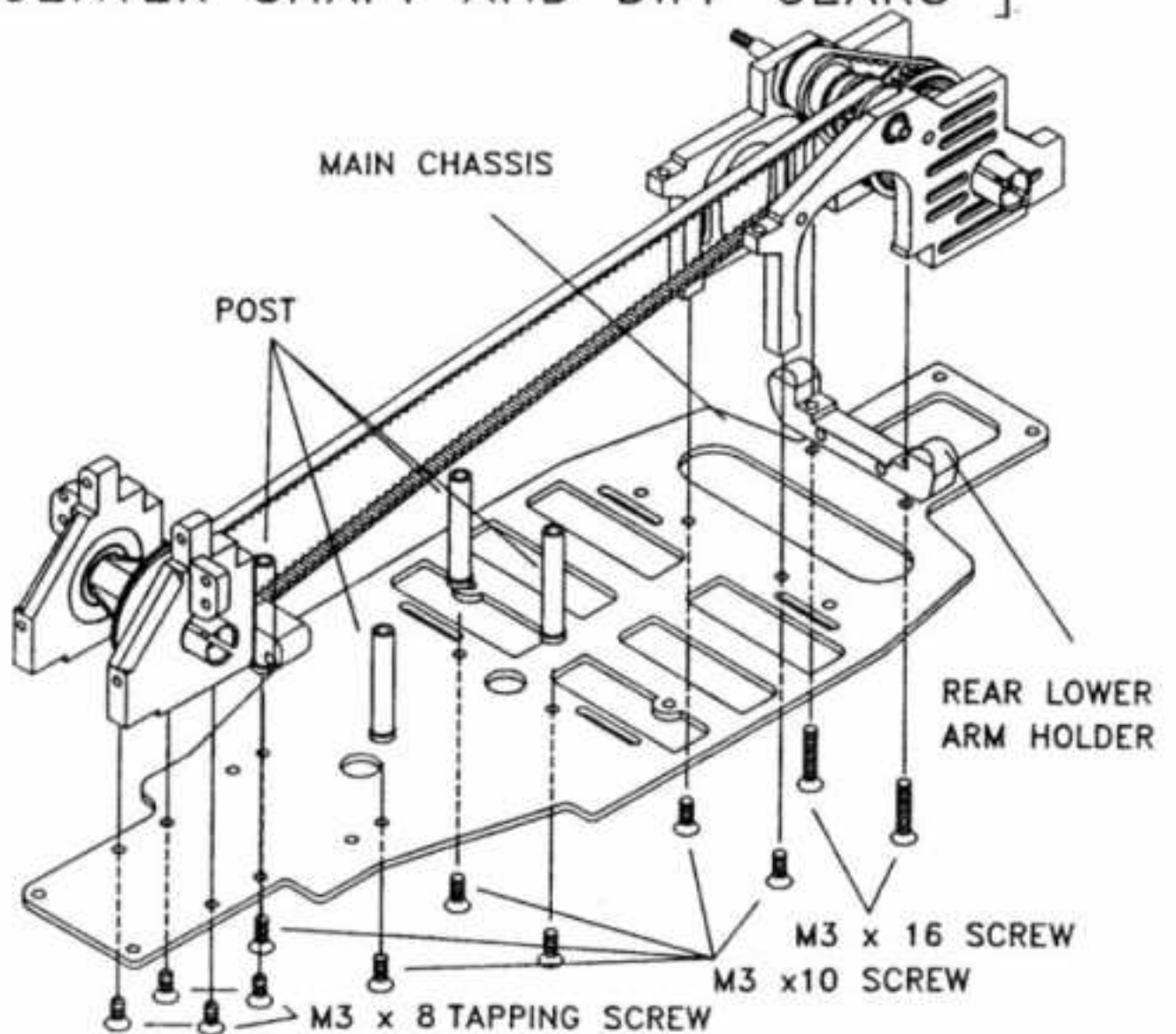

## 4. [ ASSEMBLING SPUR GEAR ]

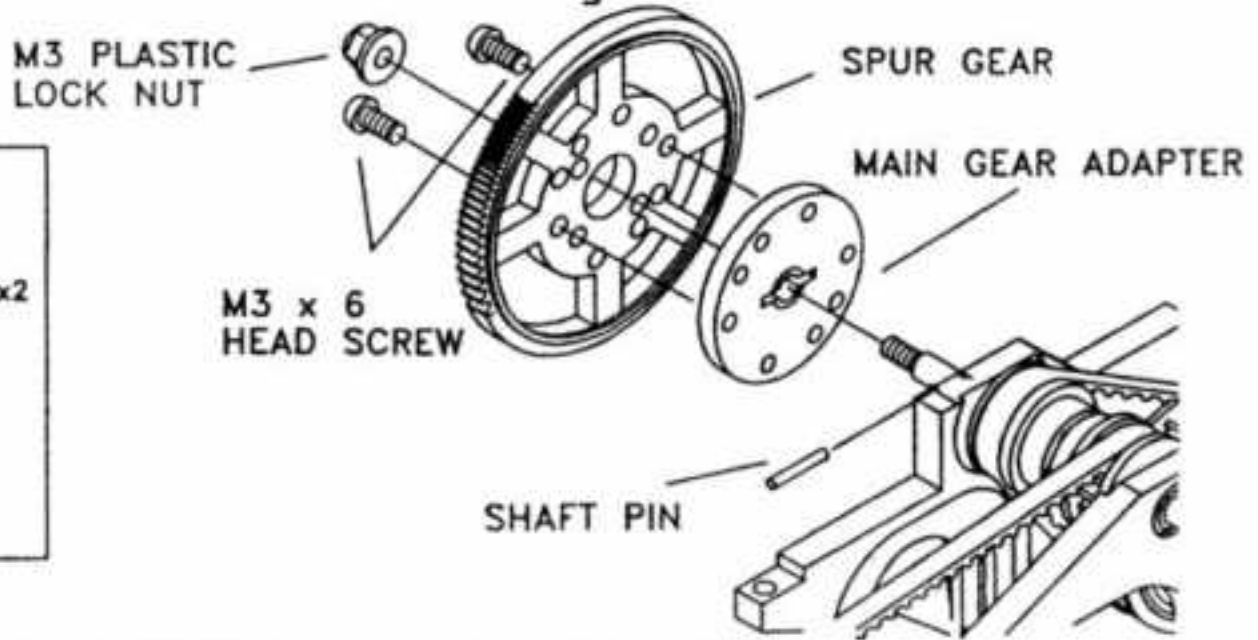

- BAG A-2**
-  M3 x 6 HEAD SCREW x2
  - M3 PLASTIC LOCK NUT x1
  - SPUR GEAR x1
  - MAIN GEAR ADAPTER x1
  - SHAFT PIN x1

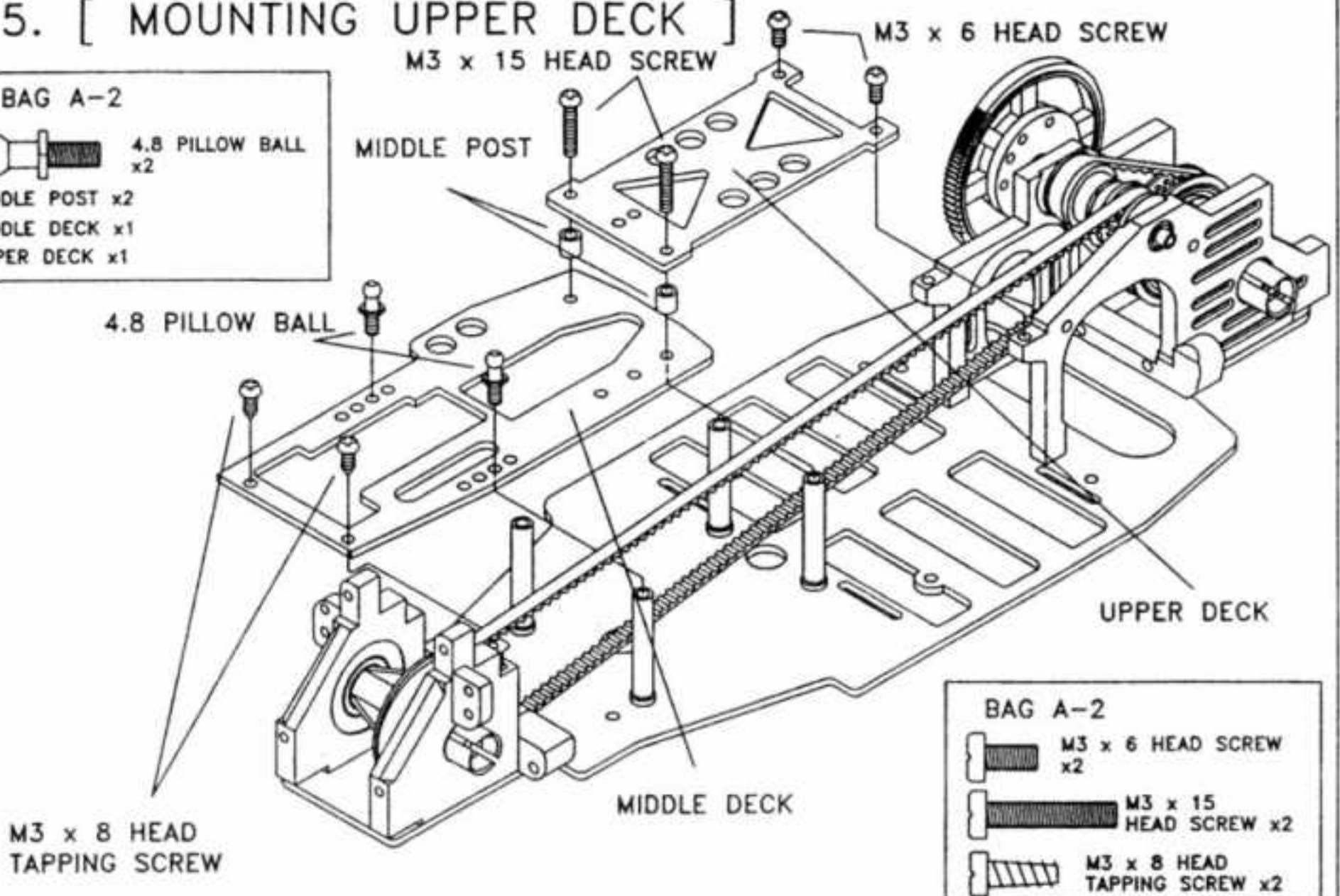

## 5. [ MOUNTING UPPER DECK ]

- BAG A-2**
-  4.8 PILLOW BALL x2
  - MIDDLE POST x2
  - MIDDLE DECK x1
  - UPPER DECK x1



- BAG A-2**
-  M3 x 6 HEAD SCREW x2
  -  M3 x 15 HEAD SCREW x2
  -  M3 x 8 HEAD TAPPING SCREW x2

## 6. [ MOUNTING FRONT SHOCK TOWER ]

- BAG A-1**
-  M3 x 25 CAP SCREW x2
- BAG A-2**
-  M3 x 8 TAPPING SCREW x4
  - DAMPER HOLDER x2
  - M3 FLAT NUT x2
  - FRONT SHOCK TOWER x1
- BAG A-8**
- COLLAR x2

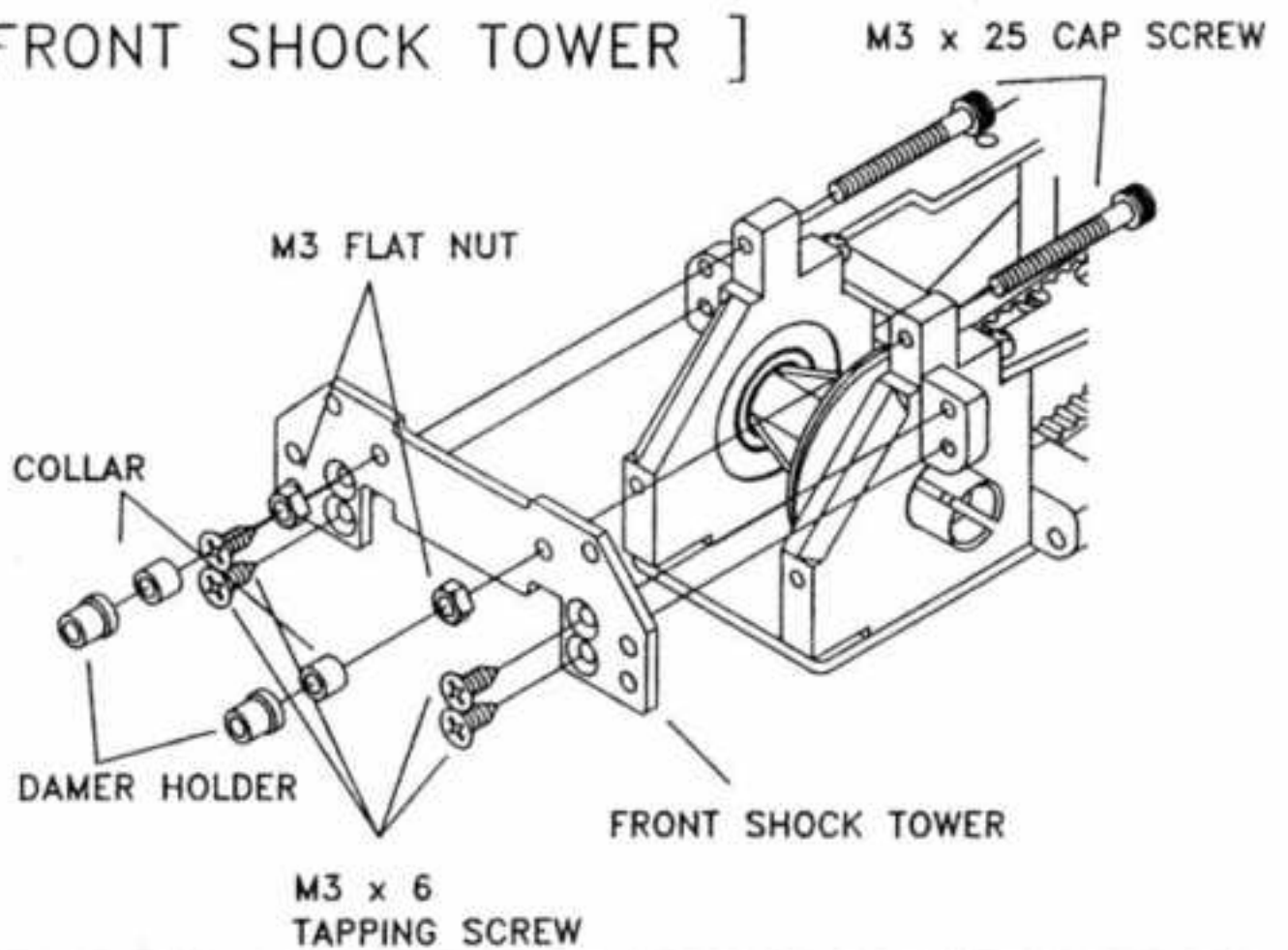

- M3 x 6 TAPPING SCREW

## 7. [ MOUNTING REAR SHOCK TOWER ]

BAG A-2	
	M3 x 6 HEAD SCREW x4
	M3 x 20 CAP SCREW x2
REAR SHOCK TOWER	
DAMPER HOLDER x2	
M3 FLAT NUT x2	
BAG A-8	
COLLAR x2	

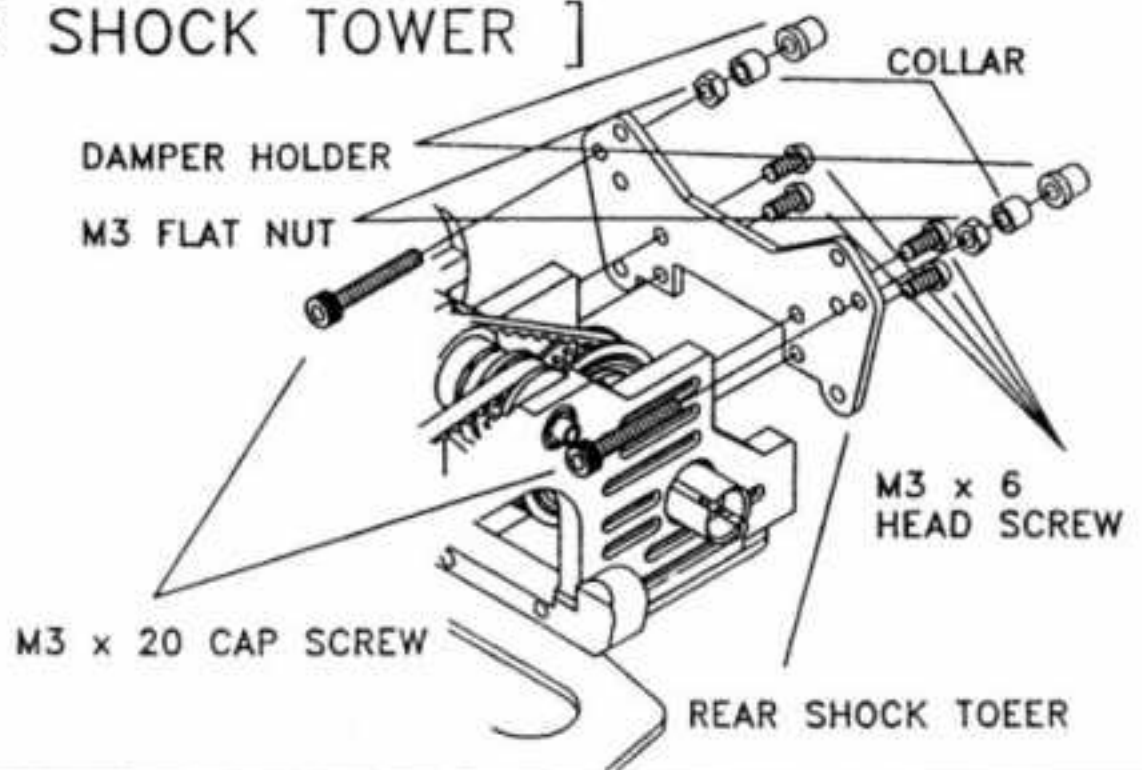

## 8. [ ASSEMBLING FRONT SUSPENSION ]

BAG A-3	
	4.8 PILLOW BALL x2
FRONT SUS-ARM x2	
BAG A-4	
	10 x 5 BEARING x4
	M3 x 16 KING-PIN SCREW x2
DRIVE SHAFT x2	
KNUCKLE x2	
5.8 BALL x2	
M2 E-RING x2	

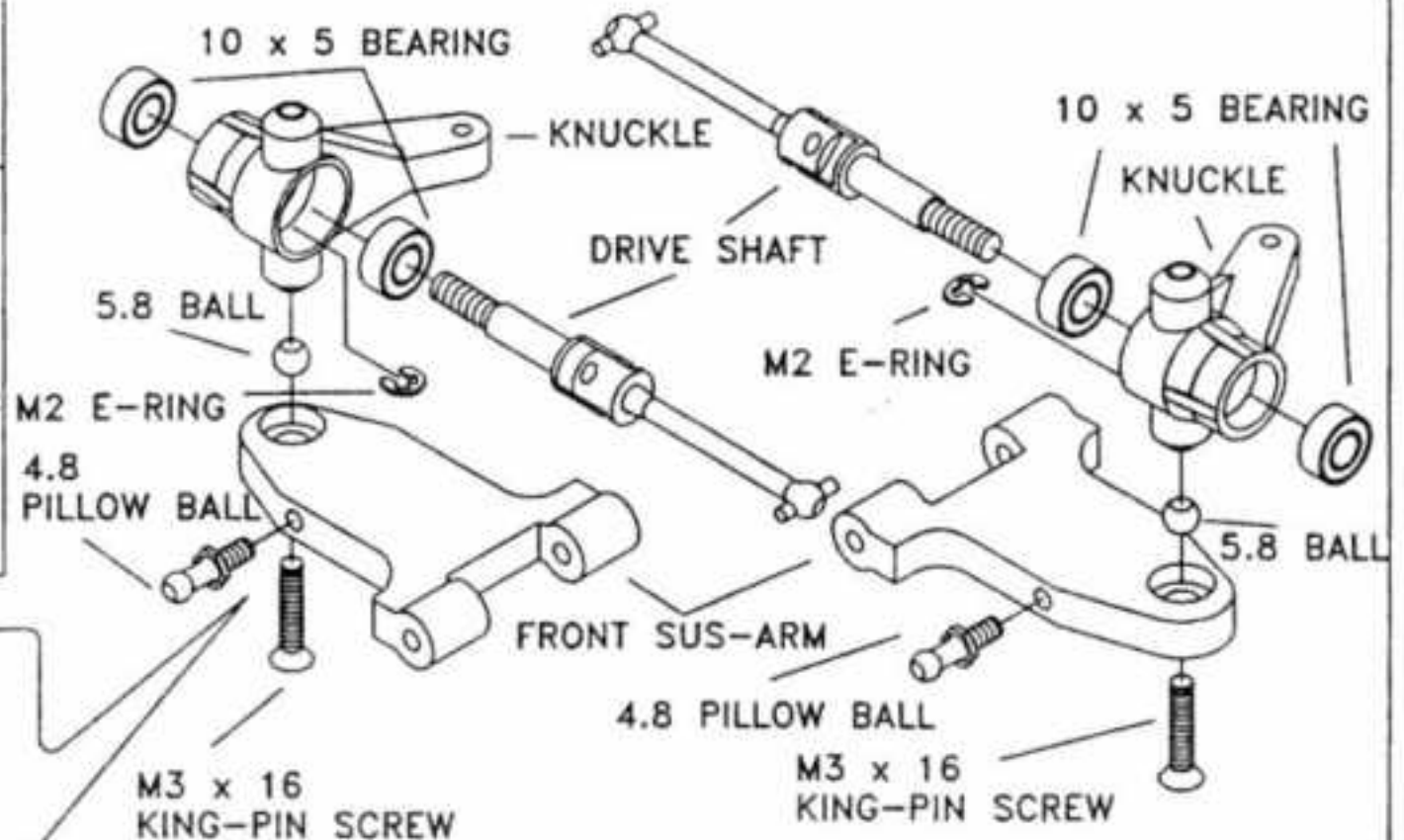
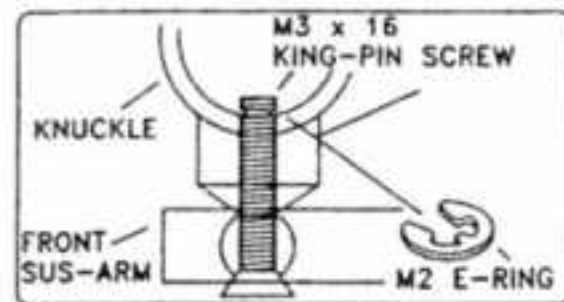



### 8.1 [ ASSEMBLING FRONT SUSPENSION ]

BAG A-4	
	M5 FLAT WASHER x2
	M3 x 12 HEAD SCREW x2
POST x2	
5.8 BALL x2	
PIVOT BALL x2	
18mm TURN BUCKLE x2	
35mm TURN BUCKLE x2	
UPPER ARM JOINT x2	
SET SCREW x2	

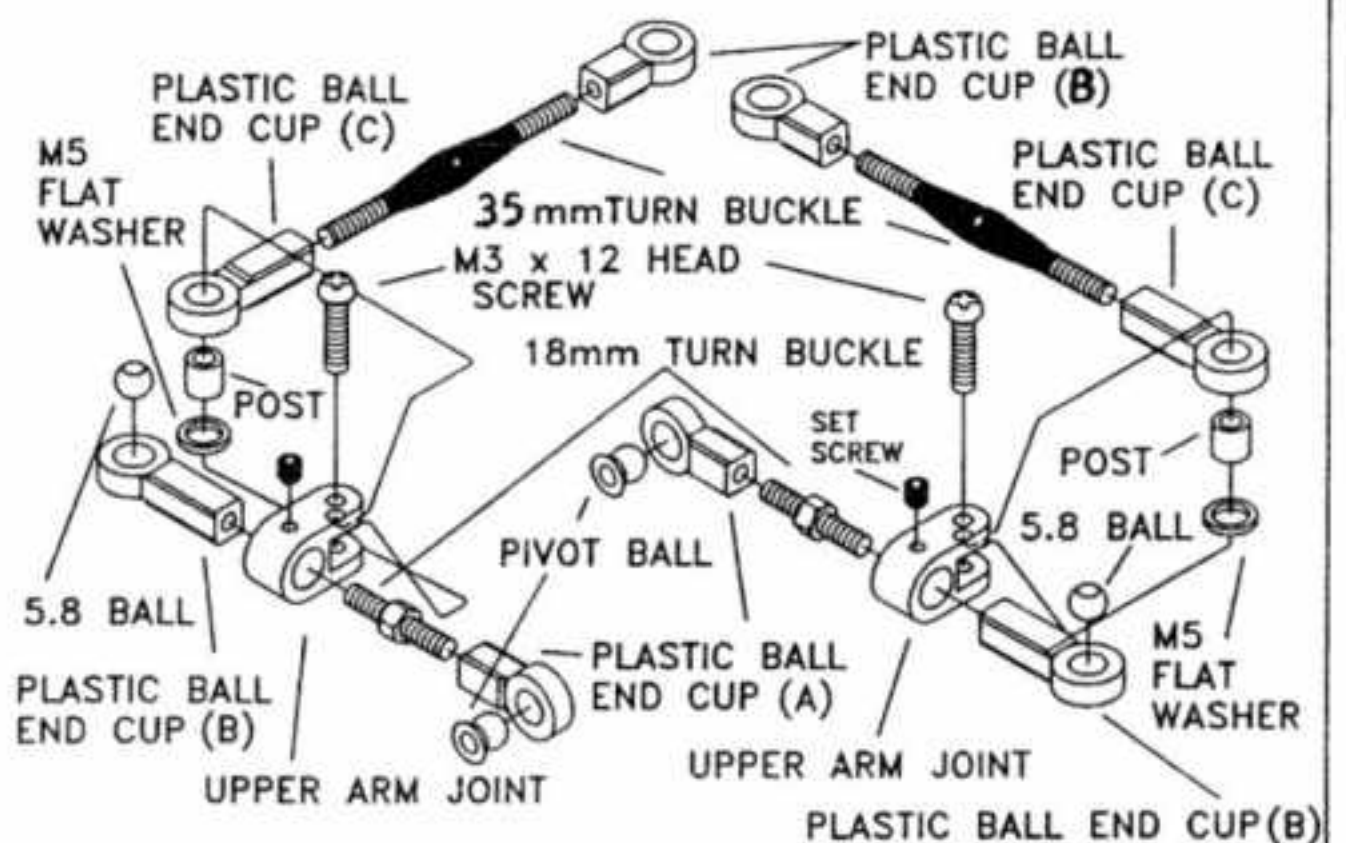
BAG A-7	
	PLASTIC BALL END CUP (A) x4
	PLASTIC BALL END CUP (B) x2
	PLASTIC BALL END CUP (C) x2



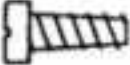
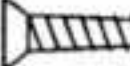

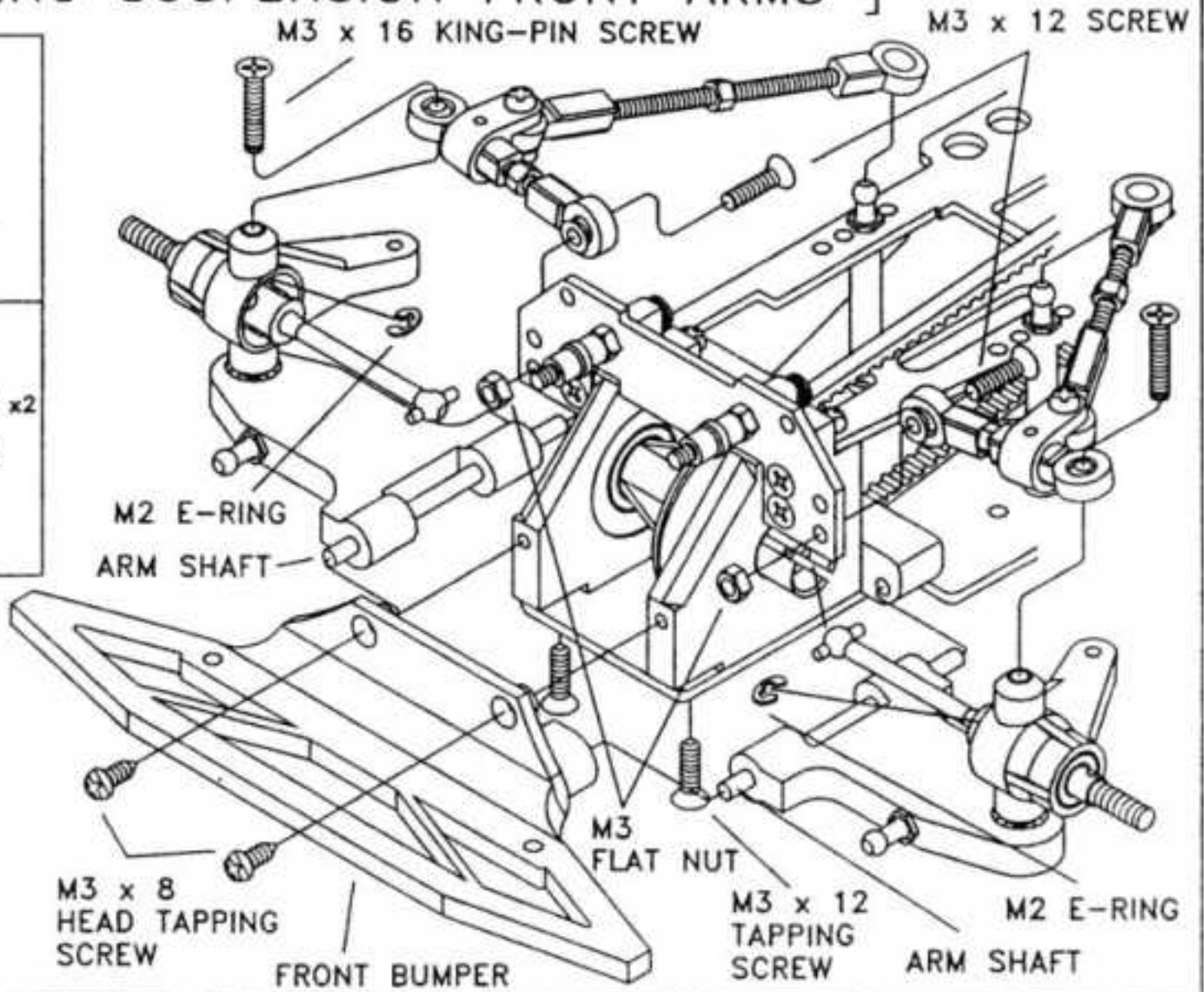

# 9. [ MOUNTING SUSPENSION FRONT ARMS ]

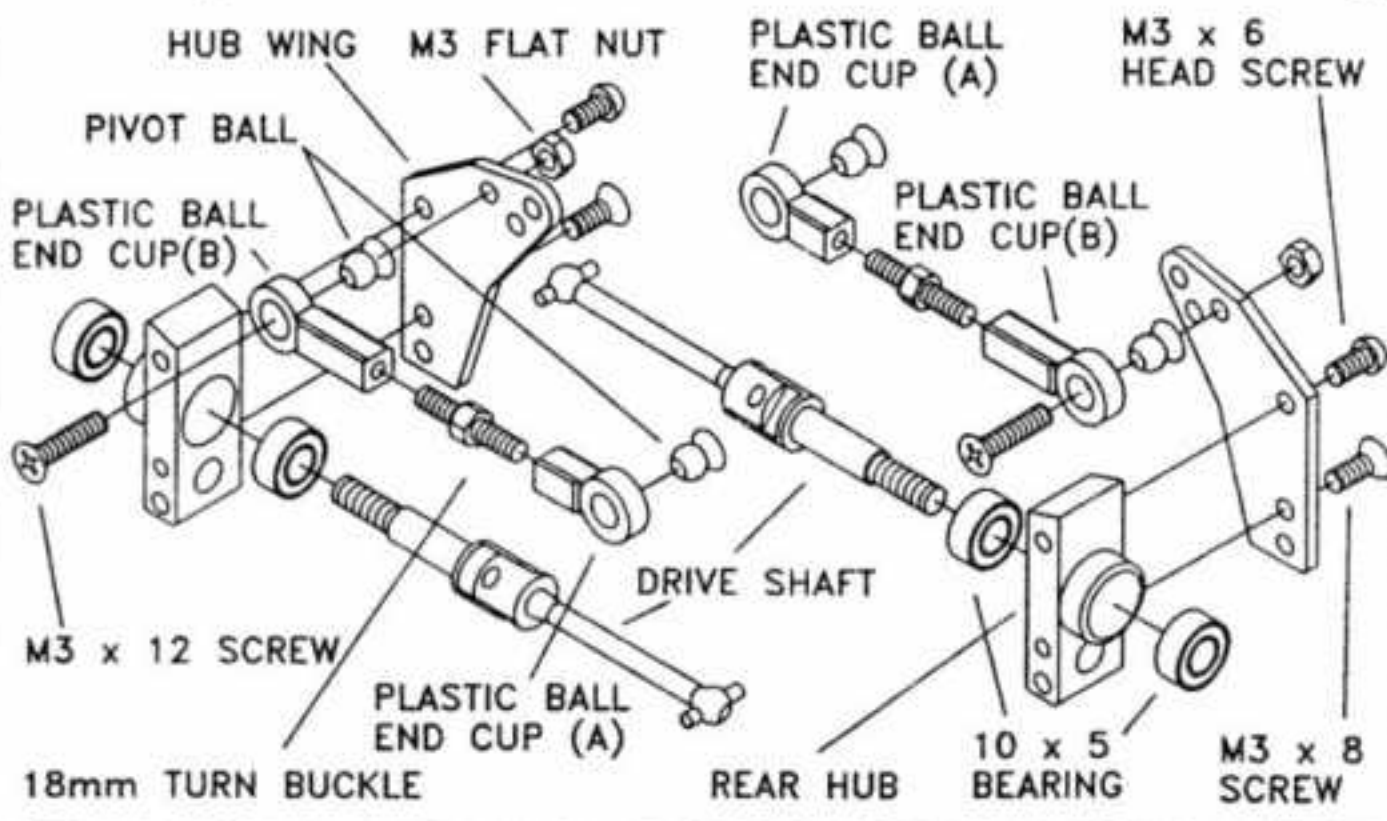

- BAG A-3**  
 M3 x 8 HEAD TAPPING SCREW x2  
 M3 x 12 TAPPING SCREW x2  
 FRONT BUMPER ARM SHAFT x2
- BAG A-4**  
 M3 x 16 KING-PIN SCREW x2  
 M3 x 12 SCREW x2  
 M3 FLAT NUT x2  
 M2 E-RING x2

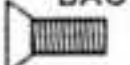

# 10. [ ASSEMBLING REAR SUSPENSION ]



- BAG A-5**  
 M3 x 8 SCREW x2  
 M3 x 12 SCREW x2  
 M3 x 8 HEAD SCREW x2  
 10 x 5 BEARING x4  
 PIVOT BALL x4  
 DRIVE SHAFT x2  
 REAR HUB x2  
 M3 FLAT NUT x2  
 18mm TURN BUCKLE x2  
 HUB WING x2

- BAG A-7**  
 PLASTIC BALL END CUP (A) x2  
 PLASTIC BALL END CUP (B) x2

# 10.1 [ ASSEMBLING REAR SUSPENSION ]

- BAG A-3**  
 4.8 PILLOW BALL x2  
 REAR SUS-ARM x2

- BAG A-5**  
 HUB SHAFT x2  
 M2.5 E-RING x2

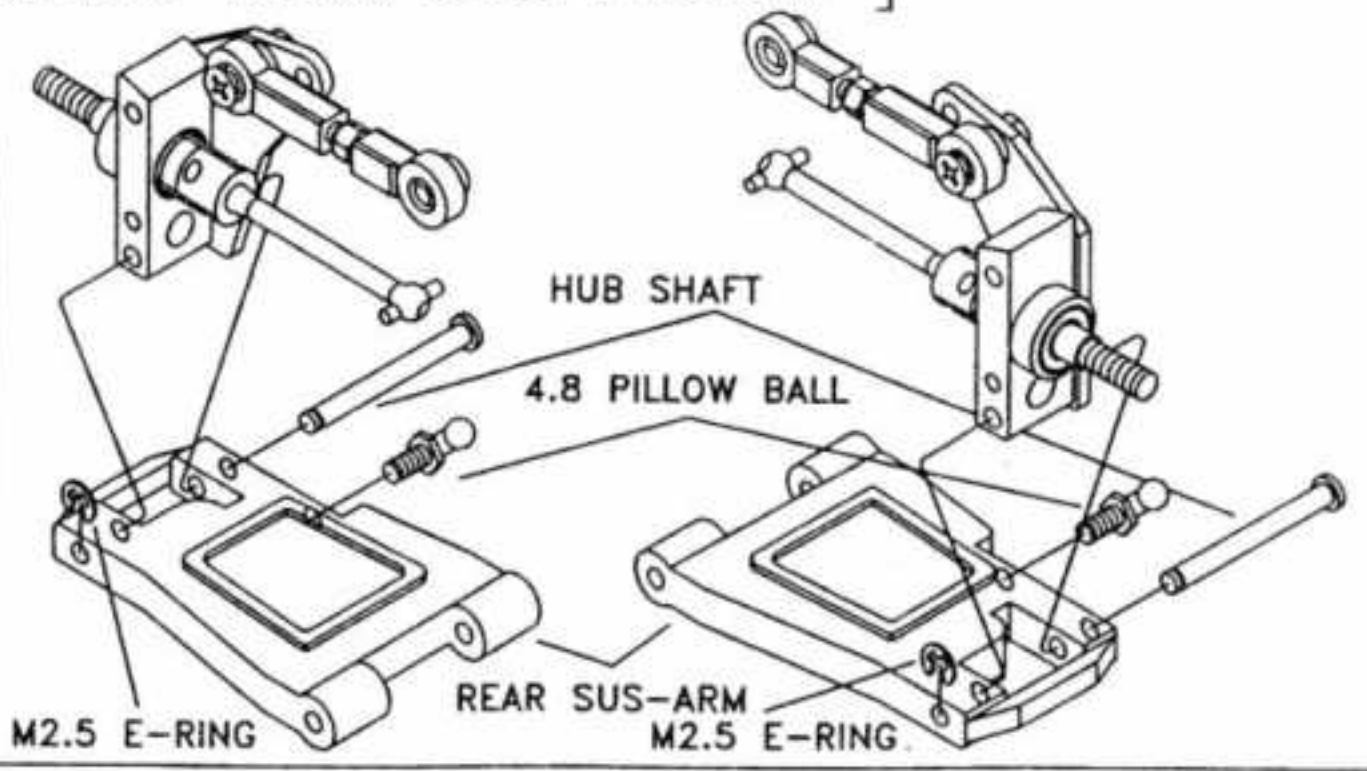

# 11. [ MOUNTING SUSPENSION REAR ARMS ]

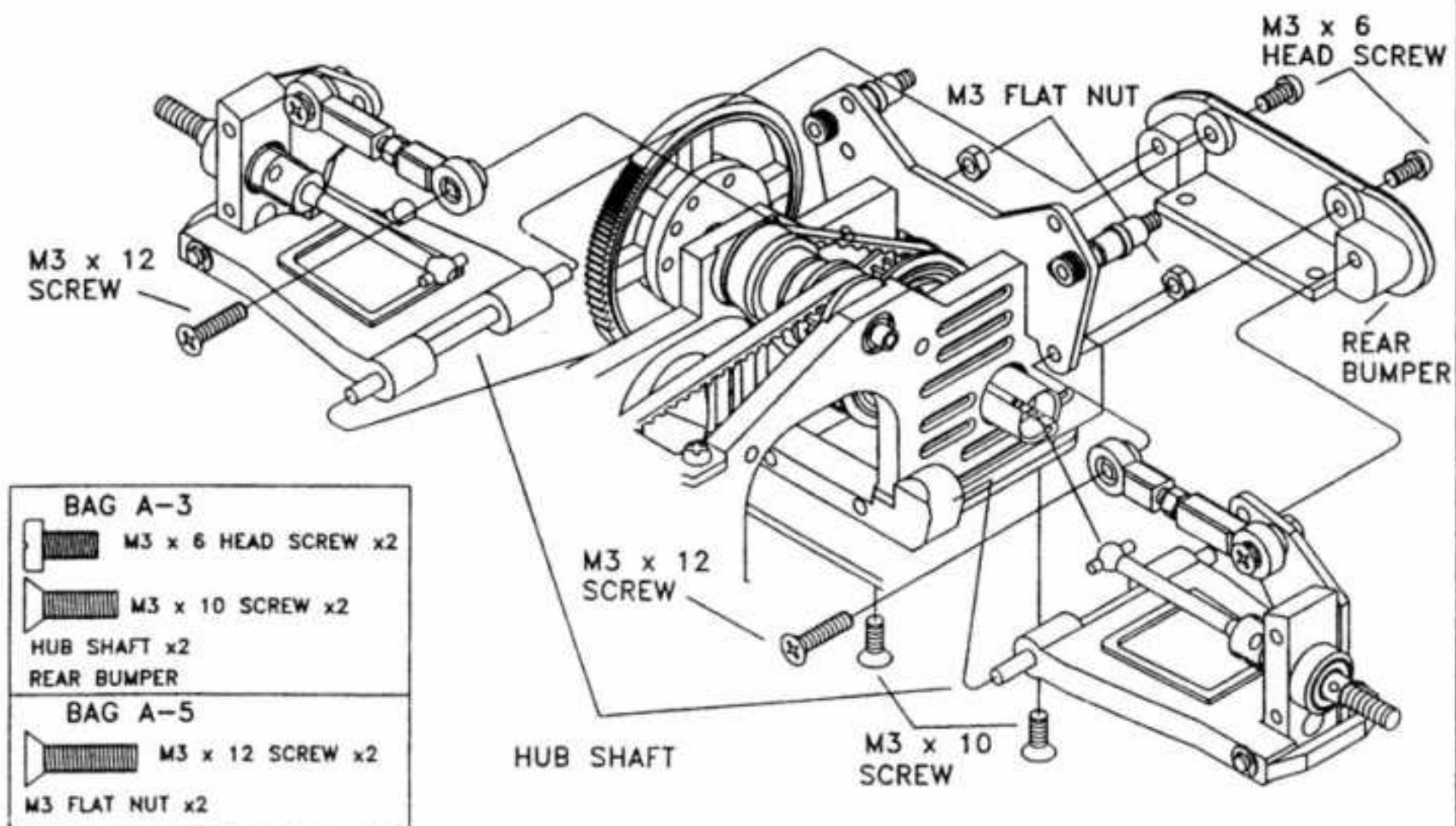

- |                |                      |
|----------------|----------------------|
| <b>BAG A-3</b> |                      |
|                | M3 x 6 HEAD SCREW x2 |
|                | M3 x 10 SCREW x2     |
|                | HUB SHAFT x2         |
|                | REAR BUMPER          |
| <b>BAG A-5</b> |                      |
|                | M3 x 12 SCREW x2     |
|                | M3 FLAT NUT x2       |

# 12. [ ASSEMBLING SHOCK ABSORBERS ]

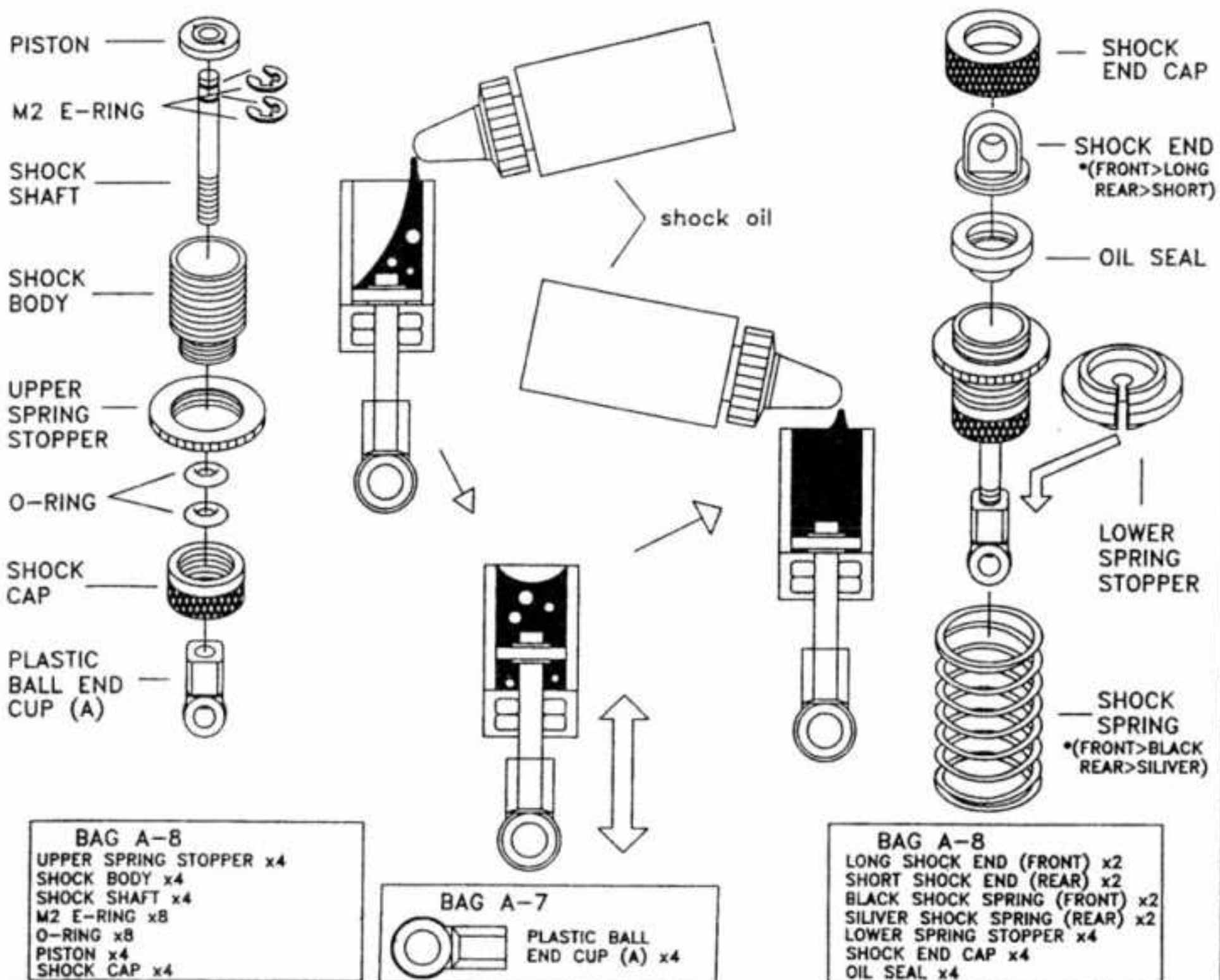

- |                |                         |
|----------------|-------------------------|
| <b>BAG A-8</b> |                         |
|                | UPPER SPRING STOPPER x4 |
|                | SHOCK BODY x4           |
|                | SHOCK SHAFT x4          |
|                | M2 E-RING x8            |
|                | O-RING x8               |
|                | PISTON x4               |
|                | SHOCK CAP x4            |

- |                |                             |
|----------------|-----------------------------|
| <b>BAG A-7</b> |                             |
|                | PLASTIC BALL END CUP (A) x4 |

- |                |                               |
|----------------|-------------------------------|
| <b>BAG A-8</b> |                               |
|                | LONG SHOCK END (FRONT) x2     |
|                | SHORT SHOCK END (REAR) x2     |
|                | BLACK SHOCK SPRING (FRONT) x2 |
|                | SILVER SHOCK SPRING (REAR) x2 |
|                | LOWER SPRING STOPPER x4       |
|                | SHOCK END CAP x4              |
|                | OIL SEAL x4                   |

# 13. [ MOUNTING SHOCK ABSORBERS & OTHER ]

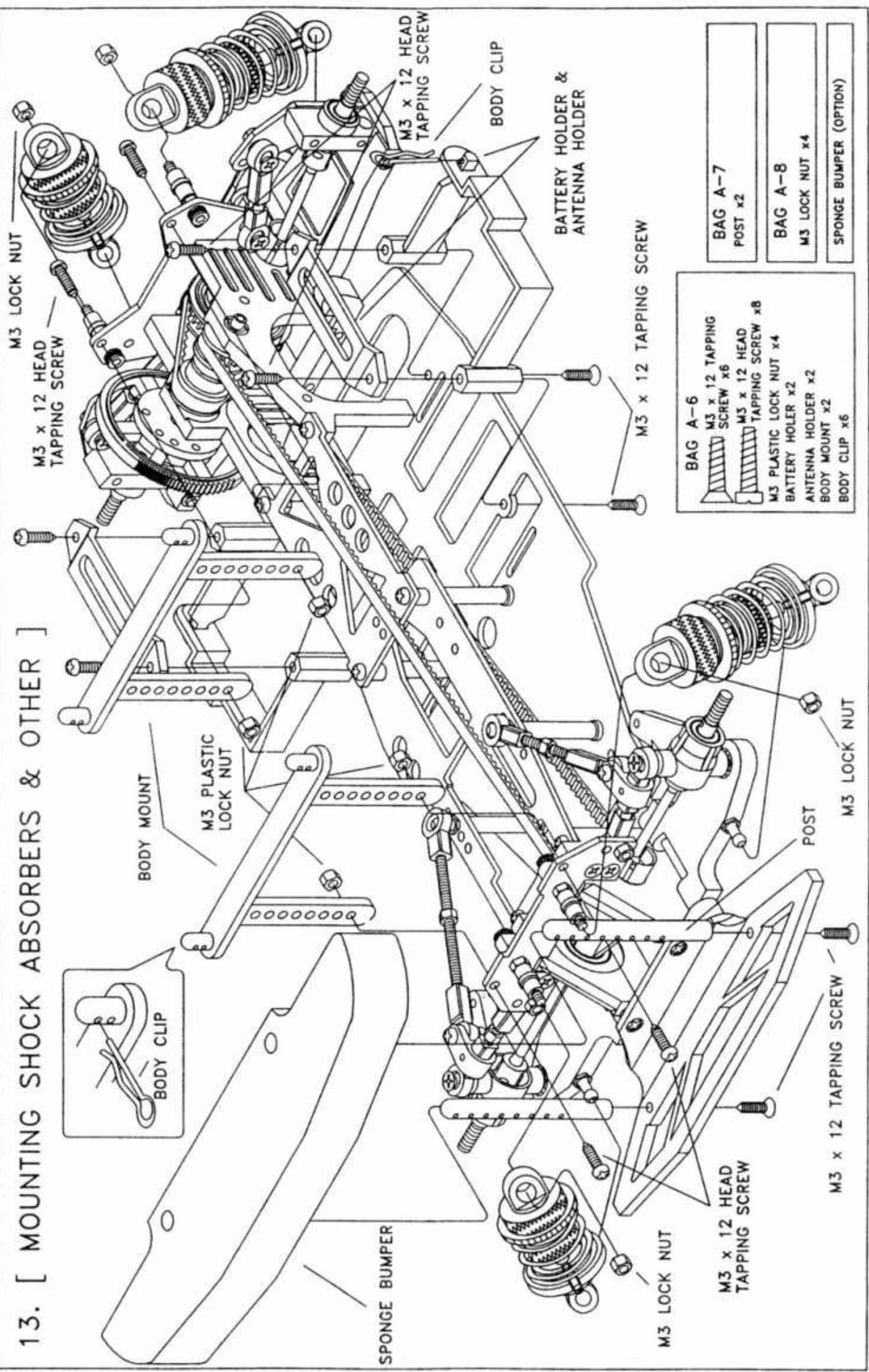

- |                |                               |
|----------------|-------------------------------|
| <b>BAG A-6</b> | M3 x 12 TAPPING SCREW x6      |
|                | M3 x 12 HEAD TAPPING SCREW x8 |
| <b>BAG A-7</b> | POST x2                       |
| <b>BAG A-8</b> | M3 LOCK NUT x4                |
|                | SPONGE BUMPER (OPTION)        |
- 
- |                        |
|------------------------|
| M3 PLASTIC LOCK NUT x4 |
| BATTERY HOLER x2       |
| ANTENNA HOLDER x2      |
| BODY MOUNT x2          |
| BODY CLIP x6           |

# 14. [ RADIO SYSTEM ]

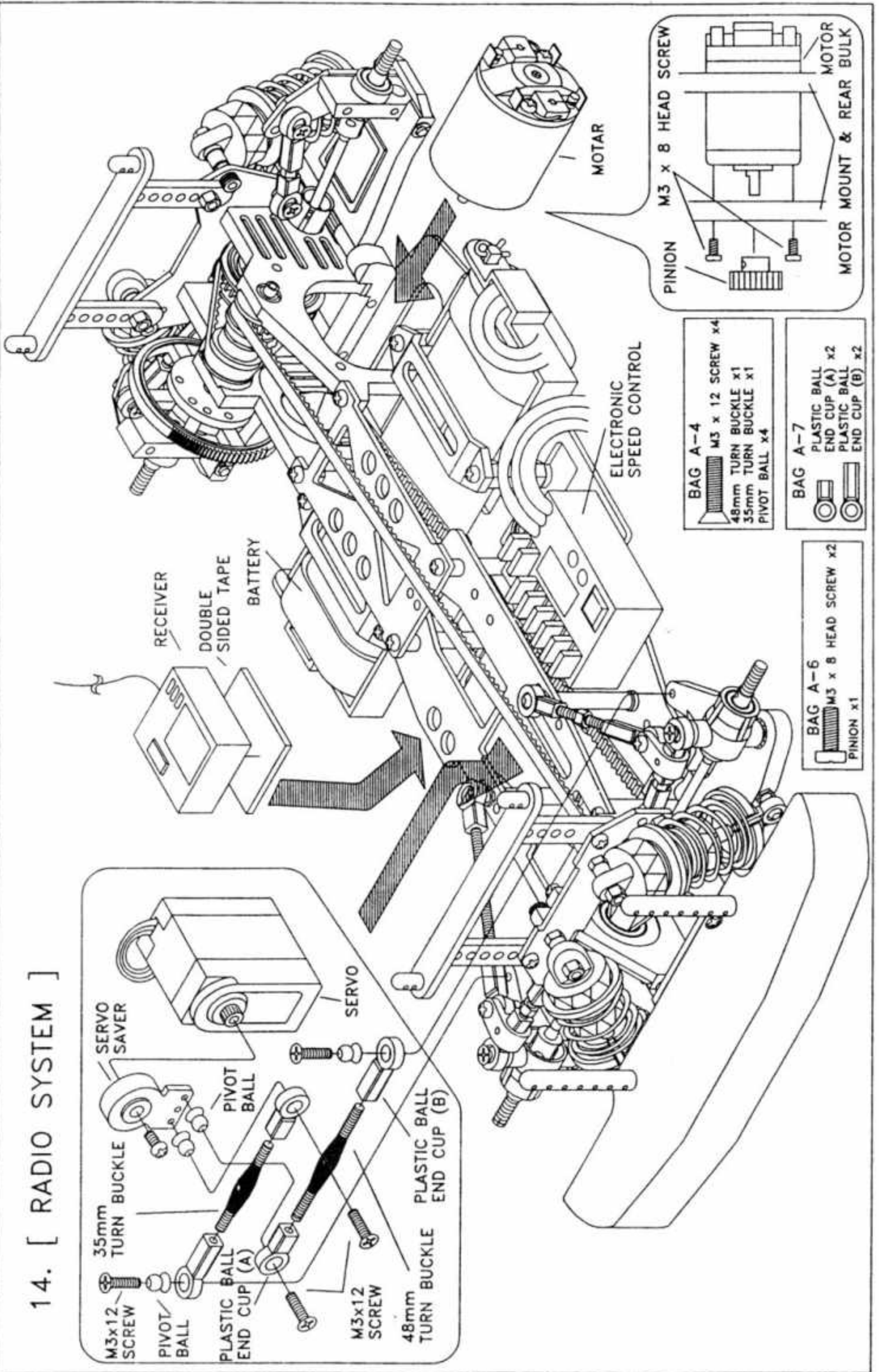

15. [ ASSEMBLING AND MOUNTING TIRE ]

